

Mini Slide Carriage

Wixroyd

P030



Material
Body - special polyethylene.
Insert nut - AISI 304 stainless steel.

Technical Notes
Compact design and suitable for a wide variety of application. Provides outstanding performance with lighter movement than ball-bearing types.
Material values:
- Coefficient of friction μ_s 0.15
- Coefficient of dynamic friction μ_d 0.10
- Limited PV value 3Mpa.m/min
 $PV = P(\text{pressure Mpa}) \times V$
(slidespeed m/min)
 $p = 0.74 \text{ Mpa}$
 $V = 12 \text{ m/min}$

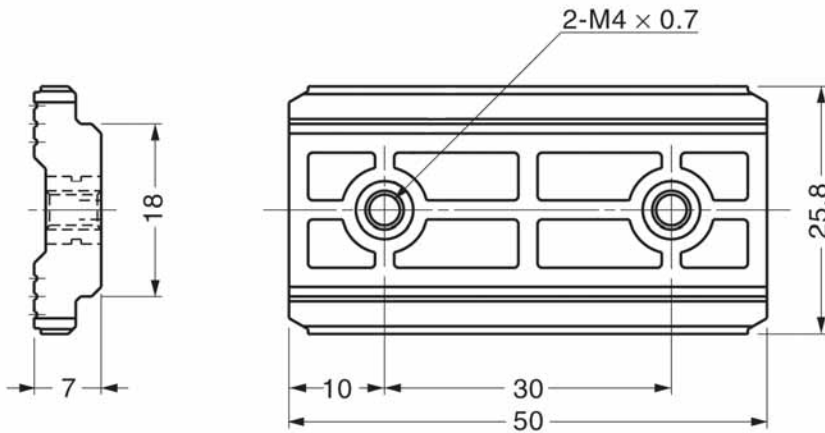

Order No.	Description	
P030.AC050	Carriage	g

Mini Slide Rail for mini slide carriage P030

Wixroyd

P035



Material
Aluminium, finish anodized.

Technical Notes
9-micron anodized film provides excellent protection against corrosion.
Compact design and suitable for wide variety of locations.

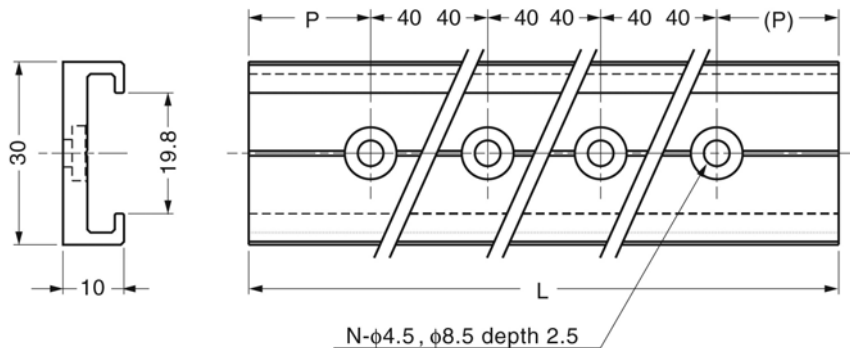

Order No.	L	P	N	
P035.AC010	100	10	3	39
P035.AC020	200	20	5	79
P035.AC040	400	20	10	159
P035.AC080	800	20	20	312
P035.AC200	2000	20	50	790