

W300



Material
Bolt: steel.
Base: polyacetal, and cap of polyamide.

Technical Notes
Please see assembly instructions for assembly method.

Levelling Feet

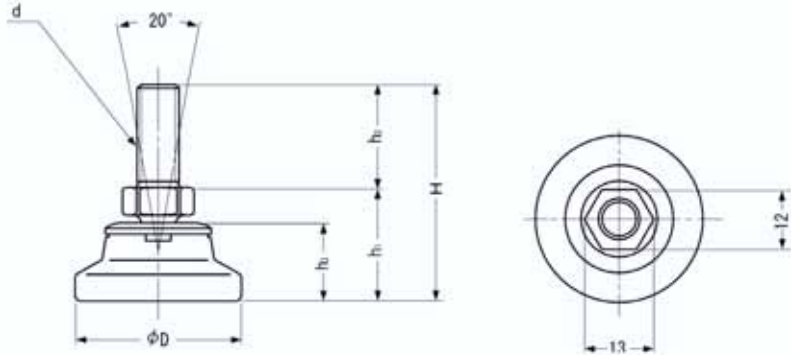

Order No.	d	D	H	h ₁	h ₂	h ₃	Max. load capacity for static load Kg.	g
W300.AC081	M 8 x 1,25	32	42,0	22,0	20	15,5	120	25
W300.AC082	M 8 x 1,25	40	42,5	22,5	20	16,0	160	30
W300.AC101	M10 x 1,50	32	42,0	22,0	20	15,5	120	29
W300.AC102	M10 x 1,50	40	42,5	22,5	20	16,0	160	34

