

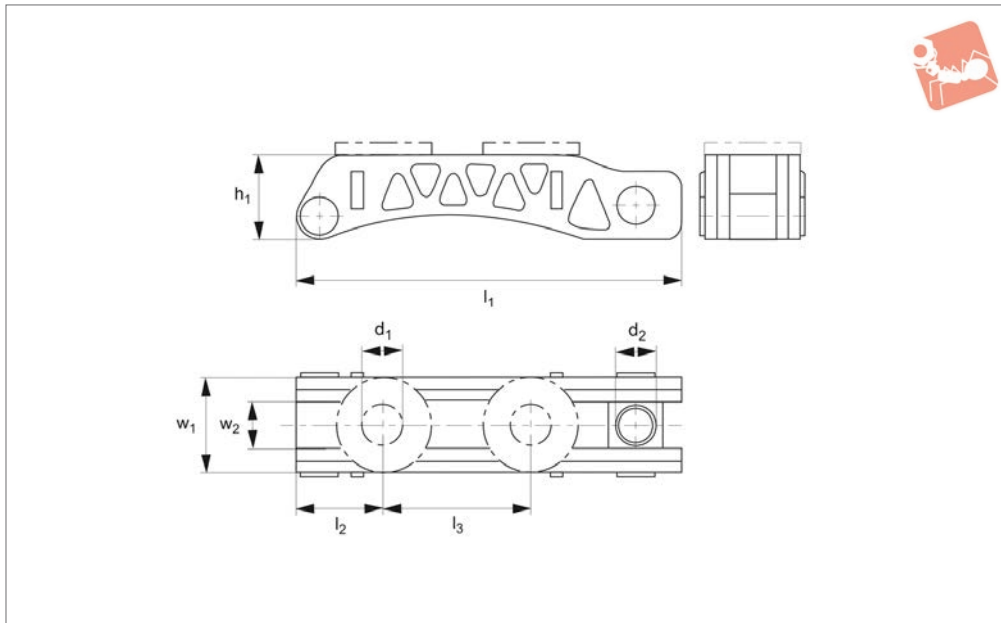

Scalloped Clamp

light design



10610.1

STANDARD MANUAL CLAMPING

Material

Steel, tempered and burnished.

Technical Notes

The weight saving device allows a 50%

reduction in weight with no effect on clamping force that can be applied. Useful for rotating applications.

Tips

For clamping, T-bolts no. 21000 (DIN 787), studs no. 21100 (DIN 6379) and cheese head screws (ISO 4762) can be used.

Order No.	Size	For clamping screw	d ₁	d ₂	h ₁	l ₁	l ₂	l ₃	w ₁	w ₂	Weight g
10610.W0022	22	M20, M22	22	M20	44	200	45	77	49	25	1289
10610.W0026	26	M24	26	M24	44	250	46	116	54	30	1630
10610.W0033	33	M30	33	M30	71	315	59	152	72	40	4522
10610.W0043	43	M36, M42	43	M30	80	400	74	209	102	54	9709