

## 10656

ADJUSTABLE VERTICAL CLAMPS

### Material

Aluminium body, supplied with clamping screw.

Clamping body key: nickel plated steel.

### Technical Notes

Can be used to increase the clamping

height of our vertical clamping systems 10655.

Order No.	Type	$h_1$	$h_2$	$d_1$	$d_2$	$d_3$	$l_1$	$l_2$	$l_3$	$w_1$
10656.W0030	Spacer	60	-	M8	-	-	73	11	-	32
10656.W0180	Key	-	38	-	16	7	-	-	140	-



## A Wide Range of Clamps to Match any Requirement

CLAMPING FORCE  
**UPTO  
50000  
NEWTONS**

**10650** All machining operations



**16000  
NEWTONS**

**10655** Light machining



**6500  
NEWTONS**

**10658** Electrical discharge machining



**6500  
NEWTONS**

**10660** Clamping and lifting

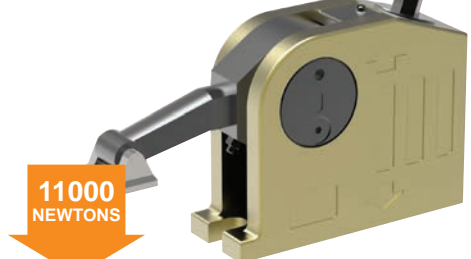

**11000  
NEWTONS**

**10661** Heavy machining



**40000  
NEWTONS**

**10670** Repetitive machining

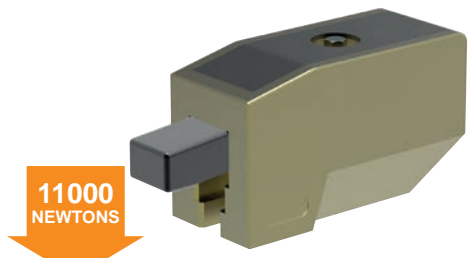

**11000  
NEWTONS**

**10675** Heavy machining



**35000  
NEWTONS**

**10678** Press Tool Clamping



**50000  
NEWTONS**



# Monobloc Clamps

stackable vertical clamping



## Clamping & Height Setting

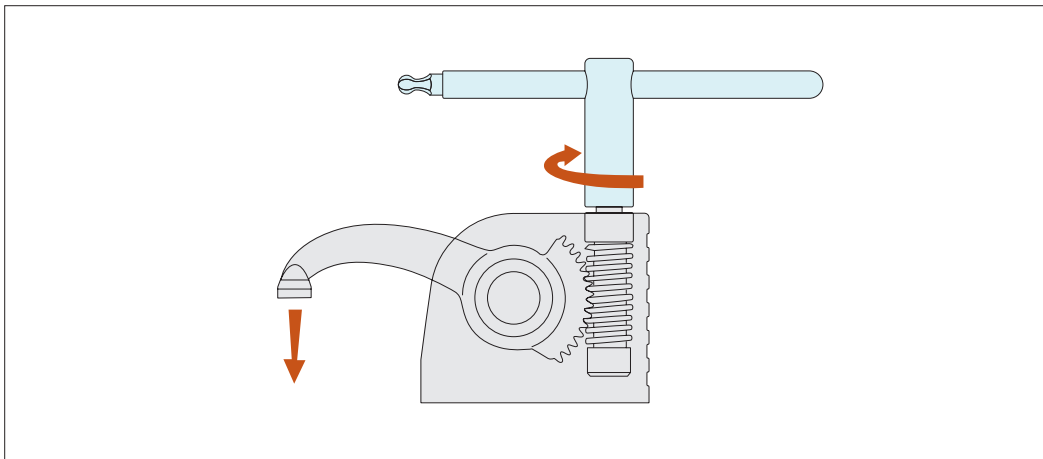

Slide the T-nut into the T-slot position and tighten the clamp onto the T-slot base, with the aid of the clamp key (shown in the image in blue).

Clamp the workpiece by twisting the key. Start machining.

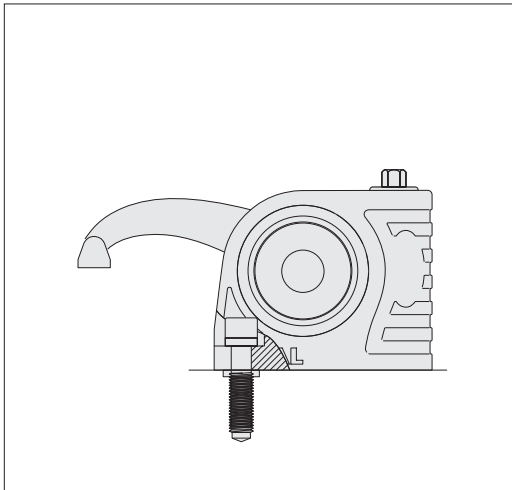

Fix to threaded bases with a special screw M10, M12, M14, M16.

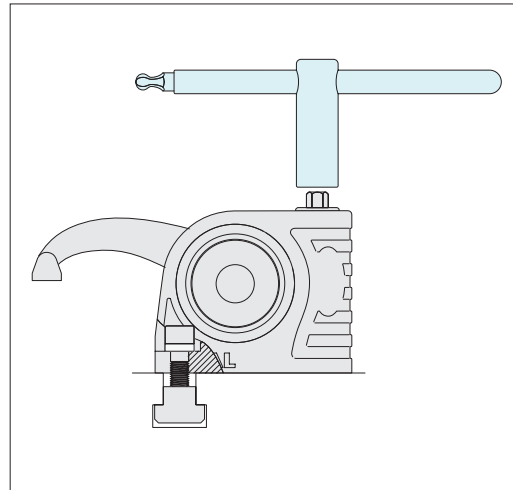

Fix to T-slots with suitable T-nuts.

When unclamped the arm and the clamp remain in position

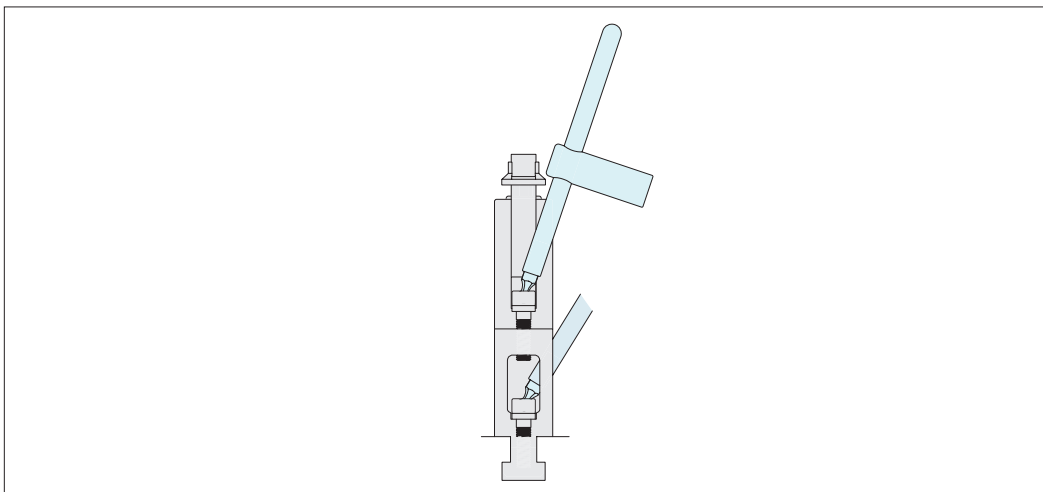

The clamps are easily stackable to achieve required clamping height.

ADJUSTABLE VERTICAL CLAMPS