

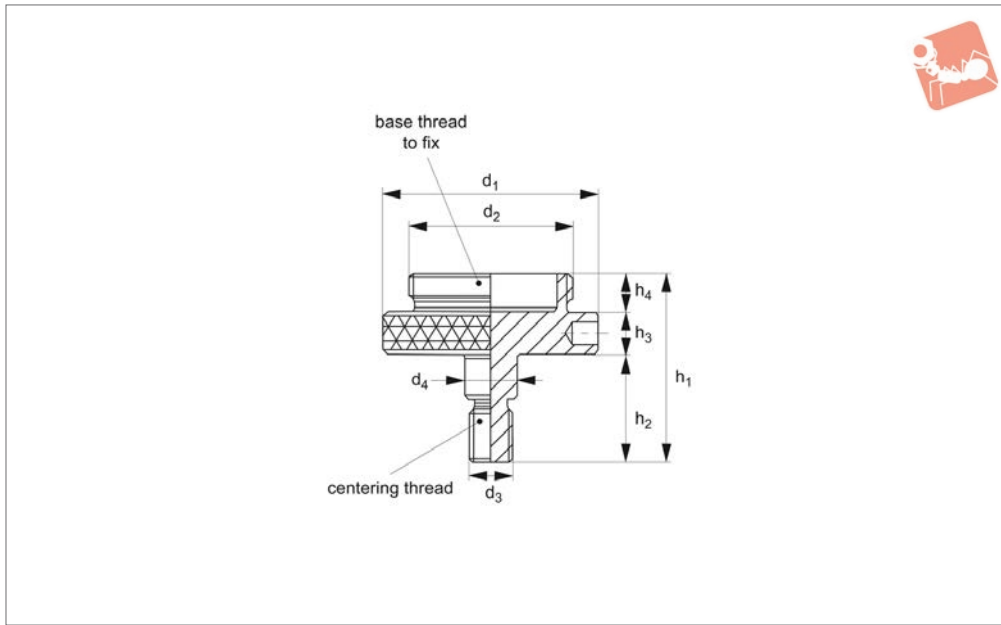

Centering Pad - Threaded for screw jacks

Screw Jacks



15062

SCREW JACKS

Material

Steel, hardened and blackened.

Technical Notes

Has threaded centering pin (M12) for securing to compatible screw jacks with corre-

sponding M12 threaded centering holes. Also equipped with M38x2 male thread for fixing screw jacks with corresponding M38x2 thread in their base.

Tips

Do not adjust screw jacks when under load. See technical pages for the table of screw jack suitability.

Order No.	d_1	d_2	d_3	d_4	h_1	h_2	h_3	h_4	Weight g
15062.W0010	50	M38x2	M10	11.9	33	25	10	9	200

