

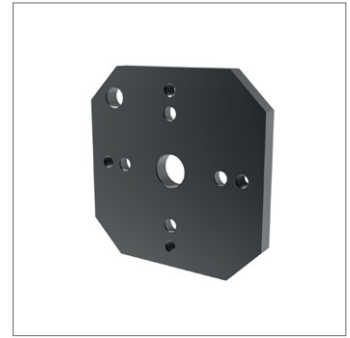

Adapter Plate - ReLock 8

8 station vice pallet or indexer mounting

Vice Clamping

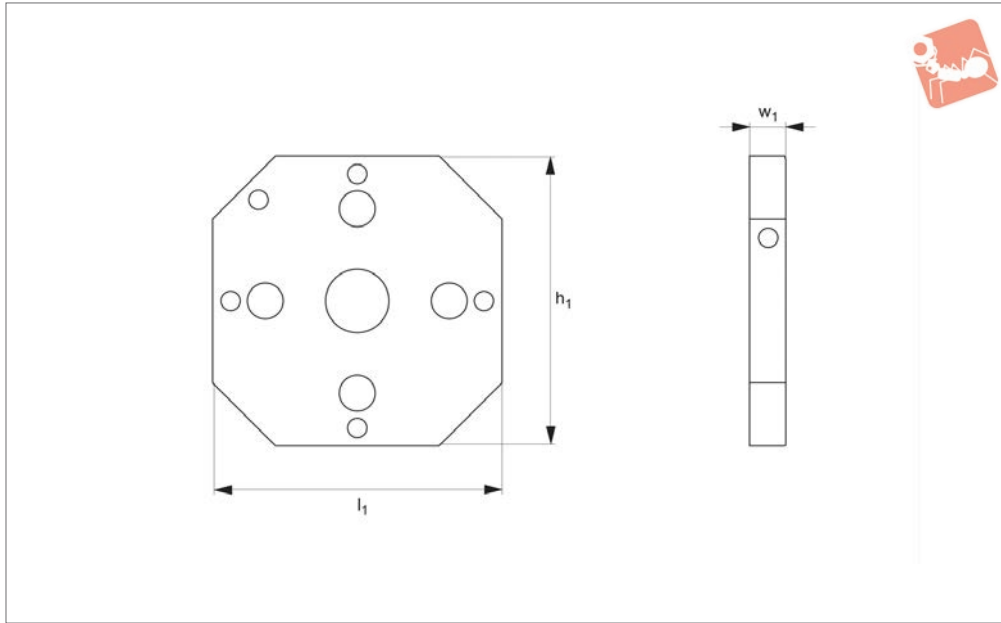

19770

VICE CLAMPING

Material

Body: 80000 PSI ductile cast iron.
Sideways flame hardened to 40 HRC max.

column vice to pallet or indexer.

Important Notes

All dimensions are in inches.

Technical Notes

Adapter plate simplifies attachment of 8-

Order No.	Vice size	l_1	h_1	w_1
19770.W0004	4"	9	9	0.75
19770.W0006	6"	12	12	1.00



Initial Cleaning

After unpacking your vice and checking the contents, wipe all surfaces with a clean rag or cloth to remove any debris or rust inhibitor that is present. This will ensure that the vice will operate at its maximum efficiency.

Operating Instructions

Behind the rear knuckle (opposite the handle end) you will find two hex screws. One is to adjust the automatic offset mechanism (discussed later) and the other is to adjust the brake mechanism for the vice (see drawing A).

Tighten Brake Mechanism

Simply tighten the brake screw in a clockwise rotation until it is snug. **DO NOT OVERTIGHTEN.** Failure to set brake properly will:

- not allow vice to open and close properly and/or
- will not allow the automatic offset mechanism to operate correctly.

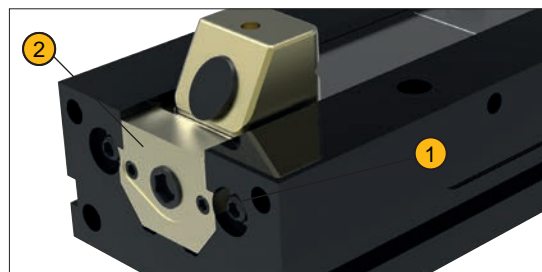

1 Offset Mechanism

2 Break assembly

Drawing A

Do not fully close vice without jaws properly mounted on vice knuckles.

The ReLock vice should only be fully closed when:

- a three piece SnapLock Machine Jaw Set is on vice
- a SnapLock Carrier Jaw Set and AccuSnap or QuickChange Master Jaw configuration is on vice

Failure to do this could result in damage to the centre chip shield.

Automatic Offset Mechanism

Behind the rear knuckle (opposite the handle end) you will find two hex screws. One is to adjust the automatic offset mechanism and the other is to adjust the brake mechanism for the vice (see drawing A on previous page). The automatic offset mechanism allows the user to set the distance that one jaw will break (i.e. open) before the next jaw breaks. The offset can be set to three distances: .030, .125, .250. The automatic part of the mechanism allows the user to change workpiece sizes without any further adjustment to the offset mechanism. For example: You set your offset to .250 and you are setting up a job that the workpiece is a 3" square then you switch to the next job where the workpiece is 4" square, the offset mechanism will automatically break the back jaw .250 for both workpieces. Similarly, you can change the offset for both jobs simply by turning the adjustment screw to the desired distance. This feature is especially useful in a horizontal machining centre application. This will prevent both workpieces from falling out of your fixture at the same time and allows you to set the distance.

Jaw Opening & Closing

When closing the vice, the front jaw (handle end) will open first. Once contact is made to the workpiece, the back jaw will move. When contact is made by the back jaw both jaws will tighten together to your desired pressure. **DO NOT OVER-TORQUE VICES.** Over-torquing will cause damage to the vice and could cause harm to the operator.

Recommended clamping pressures:

4": 0-6,000 lbs. 6": 0-12,000 lbs. 8": 0-16,000 lbs.



Mounting Information

2-station Vices

This vice has two, standard mounting options:

1. The bottom of the vice has four (4) locating holes and four (4) cap screw holes for mounting. The cap screw holes can be accessed through the top of the vice. When SnapLock Jaws are mounted on the vice the cap screw holes are completely covered preventing any coolant, fluid or chips from entering the holes. This option will allow you to mount vices very close to each other without interference.
2. The other option is to utilise the slots on either side of the vice in conjunction with toe or strap clamps.

8-station Vices

All standard baseplates come with a 50mm centre bushing and edge locating. Please refer to catalogue for specific mounting specifications.

Maintenance and Cleaning

Like any piece of quality equipment, the ReLock vice will need to periodic cleaning and maintenance to prevent lock-up and ensure maximum efficiency. The entire side segment of the vice can be easily removed and replaced.

1. Remove all jaws and accessories from the vice.
2. Remove the two retaining screws on one of the ends (or top only of 8-Station Vice).
3. Loosen the brake mechanism to allow the segment to slide freely. Do not remove screw.
4. Use the SnapLock pry wrench to lift and slide the centre chip shield locking wings onto bed of vice.
5. Slide the entire segment out of the vice way.
6. Be sure to set the chip shields aside until needed for re-assembly.
7. Place segment on table or flat surface.
8. Use the vice handle to separate the two sections of the slide segment making sure that the segment does not turn with the lead screw.
9. Remove rubber seal from the lead screw and inspect for damage.
10. Completely clean all surfaces and holes from all coolant, fluids and chips.
11. Grease both the external and internal threads of the lead screw.
12. Remove the two screws from the handle end of the front segment and remove plate.
13. Push the lead screw through the front segment to expose thrust washers.
14. Grease all thrust washers, push front segment back onto lead screw and replace plate with screws.
15. Remove the screw from the top of each knuckle and grease the SnapLock plunger assembly.
16. Re-assemble plunger assembly.
17. Clean entire vice body especially the centre way before re-assembling vice.
18. Place seal back onto the lead screw making sure to push it past the threads.
19. Assemble two slide segment units back together by again preventing the segments from turning while screwing the lead screw back into the rear segment.
20. Once external threads are not visible, place the seal back into the slot provided by using a small screwdriver or tool. Make sure that the seal is properly installed. Failure to do this can result in damage to the vices' internal mechanisms.
21. Place the outside chip shields onto the proper knuckles. Shields are notched to fit only one end. Failure to do this will allow coolant and chips into the lead screw area and cause binding.
22. Slide rear segment into the vice.
23. Place the centre chip shield into the slot prying the wings onto the bed of the vice.
24. Slide the rest of the segment in to position making sure that the outside chip shields slide under the centre chip shield.
25. Replace retaining screws in vice.

This maintenance procedure should be done periodically.

The frequency of this procedure depends on how much you use your vice.