

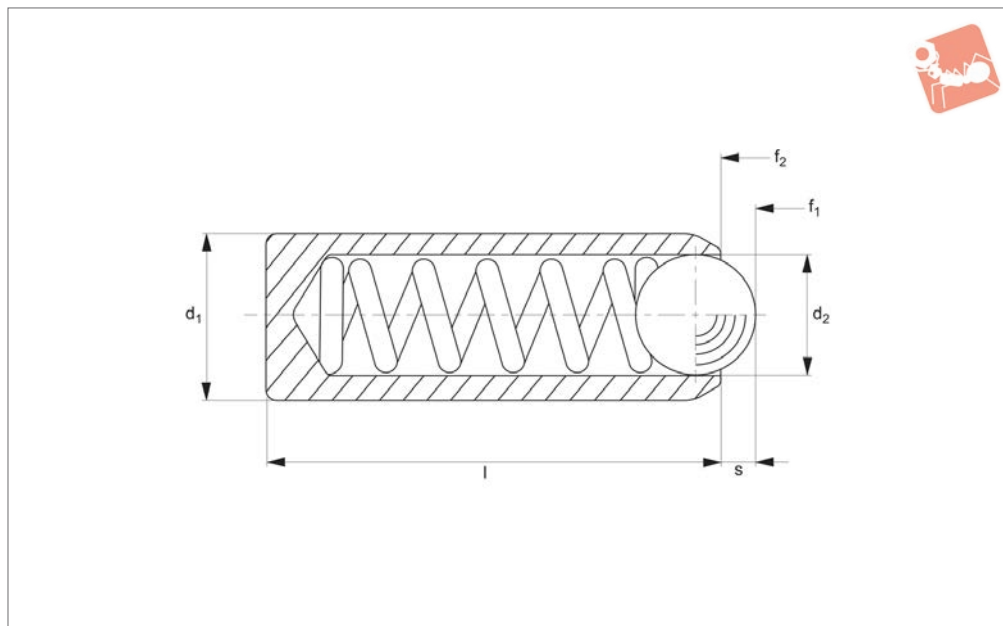

Spring Plungers

smooth model, without collar - stainless steel



32280

SPRING PLUNGER & DETENT PINS

Material

Body: stainless steel 1.4305 (AISI 303).
Ball: ball bearing steel 1.3505 (100Cr6) hardened.
Spring: stainless steel

Technical Notes

Used for locating, applying pressure or

lifting off.

Temperature range up to +250°C. Spring load * = statistical average value.

Tips

These are press fit spring plungers, use tolerance of F8 for easy fit, or H9 when tight fit required. These tolerances vary

with material type, hence a trial hole is recommended.

Special types available on request.

Order No.	Pressure	d ₁ ±0.04	d ₂	l ₁	s ₁	Spring load F ₁ N ≈	Spring load F ₂ N ≈	Weight g
32280.W0306	Standard pressure	2.0	1.0	3.5	0.3	0.8	1.5	0.1
32280.W0308	Standard pressure	2.5	1.5	5.0	0.40	2.8	4.7	0.2
32280.W0310	Standard pressure	3.0	2.0	7.0	0.7	4.5	7.5	0.4
32280.W0312	Standard pressure	3.5	2.5	9.0	0.8	6.0	14.5	0.6
32280.W0315	Standard pressure	4.0	3.0	11.0	0.9	8.0	14.0	0.8
32280.W0317	Standard pressure	4.5	3.2	12.0	1.0	9.5	16.5	1.1
32280.W0320	Standard pressure	5.0	3.5	13.0	1.0	11.0	18.0	1.5
32280.W0322	Standard pressure	5.5	4.0	14.0	1.2	15.5	25.0	1.9
32280.W0325	Standard pressure	6.0	4.5	15.0	1.5	18.0	31.0	2.3
32280.W0327	Standard pressure	8.0	6.0	18.0	2.0	24.0	45.0	5.0
32280.W0330	Standard pressure	10.0	8.0	20.0	2.5	26.0	49.0	8.3
32280.W0332	Standard pressure	12.0	10.0	22.0	3.5	41.0	86.0	12
32280.W0356	High pressure	2.0	1.0	3.5	0.3	1.3	2.2	0.1
32280.W0358	High pressure	2.5	1.5	5.0	2.5	4.7	7.1	0.2
32280.W0360	High pressure	3.0	2.0	7.0	0.7	7.8	11.6	0.3
32280.W0362	High pressure	3.5	2.5	9.0	0.8	12.0	18.0	0.5
32280.W0365	High pressure	4.0	3.0	11.0	0.9	15.0	22.0	0.7
32280.W0367	High pressure	4.5	3.2	12.0	1.0	18.7	25.1	1.0
32280.W0370	High pressure	5.0	3.5	13.0	1.0	19.3	26.6	1.4
32280.W0372	High pressure	5.5	4.0	14.0	1.2	25.1	39.2	1.8
32280.W0375	High pressure	6.0	4.5	15.0	1.5	36.0	60.5	2.3
32280.W0377	High pressure	8.0	6.0	18.0	2.0	57.0	103.5	5.2
32280.W0380	High pressure	10.0	8.0	20.0	2.5	61.0	110.0	8.5
32280.W0382	High pressure	12.0	10.0	22.0	3.5	68.0	143.0	13

Spring Plunger & Detent Pins



Spring Plungers
smooth model, without collar - stainless steel



SPRING PLUNGER & DETENT PINS

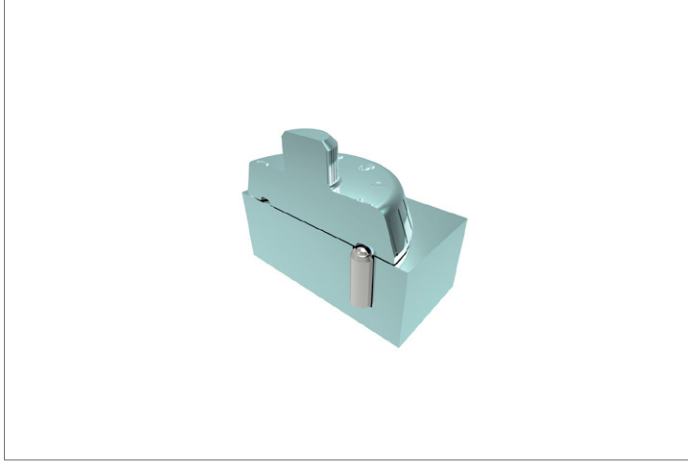



Wixroyd Spring Plungers - A Range of Endless Possibilities

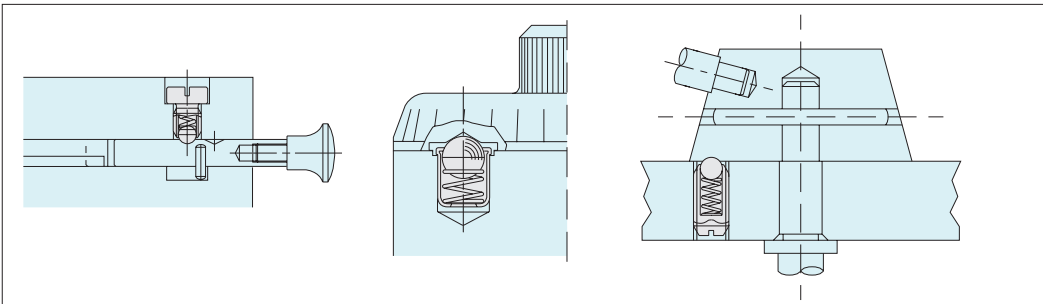

Made of high quality steel and stainless steel, Wixroyd's Spring Plunger range is proven to be reliable for millions of repetitions in securing, positioning, positive locking, indexing and quick release. Their application is limited only by the imagination!

Three push-fit spring plungers no. 32000 have been added to the design of this recessed commercial light fitting. The push-fit design of the plunger makes for easy assembly during production. Their use greatly simplifies the mounting and servicing of the units, reducing handling costs and saving valuable operator time.

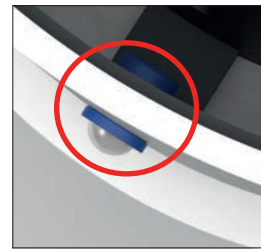

Commercial Lighting

Used in conjunction with a simple hinge, Wixroyd spring plunger 32300 provides an easy and secure means to positively position and secure the back panel of a blood gas analysis machine. With both brass and stainless steel varieties, our spring plungers have a wide range of application in the medical, pharmaceutical, food and drink processing industries.

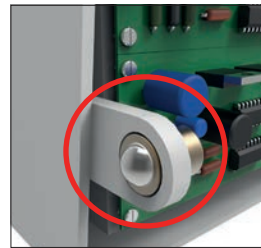

Medical Applications

Uses

- For location, applying pressure and "lifting off".
- Securing and positioning.
- Positive locking and indexing.
- Quick release.

Industry Sectors

- Machine and fixture design.
- Measuring equipment.
- Electronic components.
- Lighting equipment.
- Medical, optics and orthopaedics.

Applications

Wixroyd Spring Plungers - Uses and Mounting Options

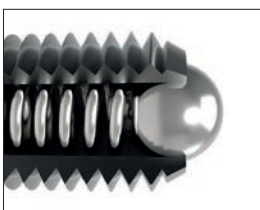

- 31400
- 31420
- 31500
- 32000
- 32100
- 32102
- 32280
- 32300
- 32302
- 32350

Mounting Options

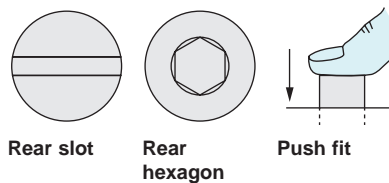

Ball Type

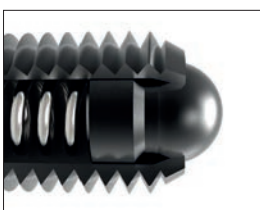

- 31000
- 31600
- 32150
- 32200
- 32282
- 32400
- 32420

Mounting Options

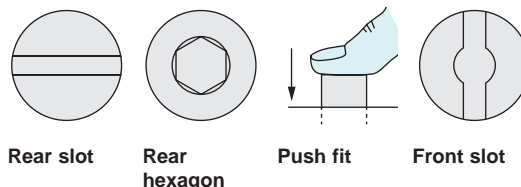

Pin Head Type



Quality products every time

100% Testing

- Every spring plunger that is produced on the Wixroyd assembly line is individually tested. That is how we guarantee the quality of our products.
- A Wixroyd spring plunger is tested against four key criteria during manufacture.

Accuracy of 'S' Stroke/ Spring Range



Accuracy of f_1 and f_2 Spring Forces



Accuracy of Ball Diameter

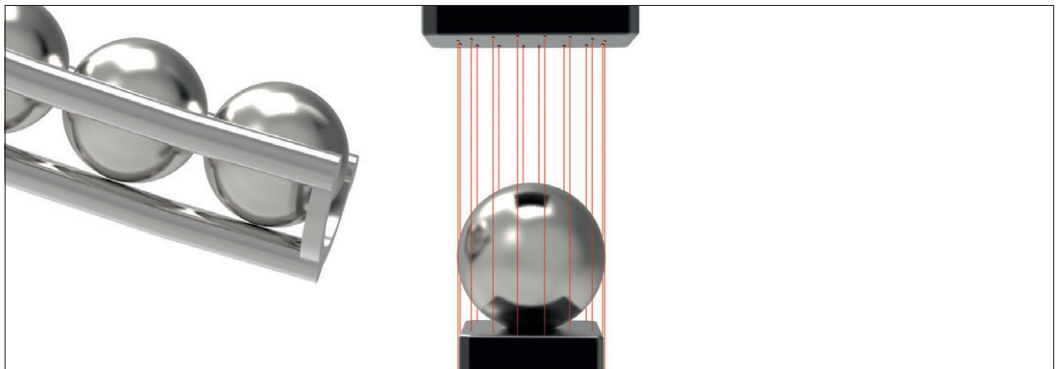

Accuracy of Thread

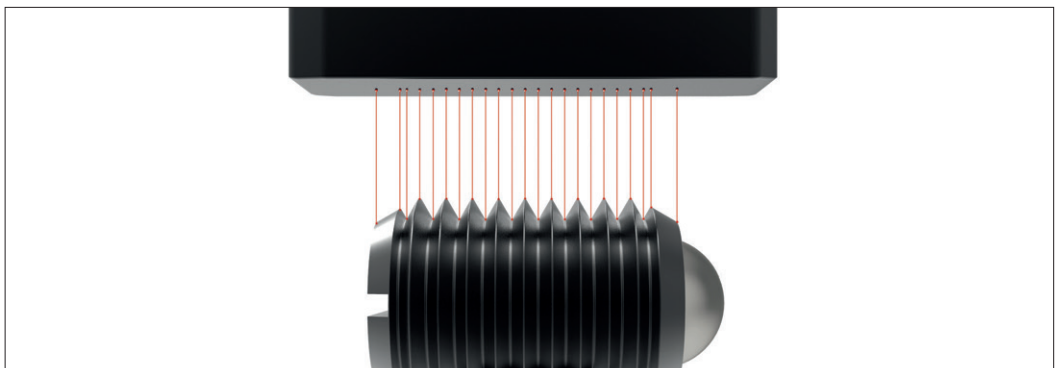



Wixroyd Spring Plungers

metric thread

31000 - 32420
Positioning Elements

	ISO metric coarse threads (mm)															
Thread (D)	3	3,5	4	4,5	5	6	7	8	10	12	14	16	18	20	22	24
Pitch	0,5	0,6	0,7	0,75	0,8	1,0	1,0	1,25	1,5	1,75	2,00	2,0	2,5	2,5	2,5	3,0

Thread Details

All Wixroyd metric spring plungers have a coarse thread.

Spring Loads

Typical Spring Repetitions

Calculating Indexing Resistance

Electrical Conductivity

Specials to Your Own Design

- s** Stroke, or movement of plunger's ball or pin.
- f₁** The force required in Newtons (N) to overcome the static strength of the spring and achieve initial movement of the plunger's ball or pin.
- f₂** The force required in Newtons (N) to fully compress the spring until the ball or pin is fully depressed against the plunger's body.

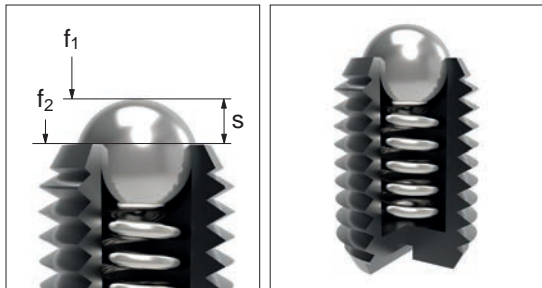

Although dependent upon a number of application specific factors, we are able to give the following guide relating to the maximum number of spring repetitions or cycles of our spring plungers.

- 100% or full stroke "s" used: approx. 300,000 cycles.
- 65% of stroke "s" used: approx 10,000,000 cycles.

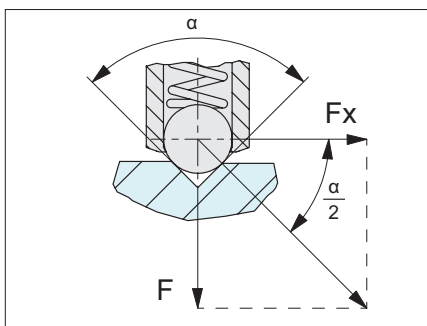
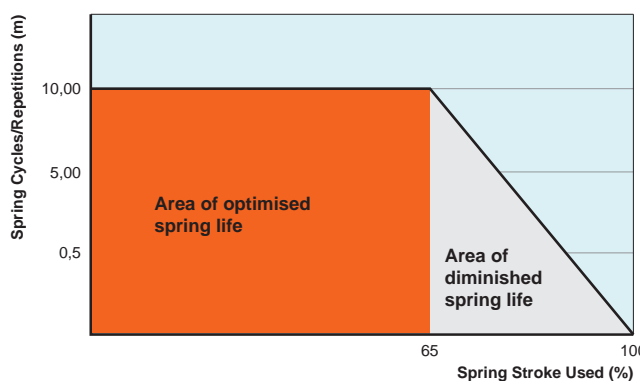

We are able to provide the following formula as an approximation of the pull or push force (N) required to 'release' a ball plunger from its indexing counterpart.

$$F_x = \frac{F}{\tan \frac{\alpha}{2}}$$

F_x = pull or push force (N)
 F = plungers spring force (see relevant product table)
 α = angle of the indexing counterpart face

For example:

For Spring plunger 31500.W0010;
 $F = 24\text{N}$ (see product table)

If $\alpha = 90^\circ$

$$F_x = \frac{24}{\tan \frac{90}{2}} = 24\text{N}$$

If $\alpha = 120^\circ$

$$F_x = \frac{24}{\tan \frac{120}{2}} = 13,8\text{N}$$

If $\alpha = 60^\circ$

$$F_x = \frac{24}{\tan \frac{60}{2}} = 41,5\text{N}$$

Important Note: This is only an approximation formula. For more accurate calculation the roughness of the counterpart surface as well as any variation in the plungers spring force (due to age or high repetitions) should be considered.

We are often asked the electrical conductivity of our spring plungers, unfortunately we are unable to provide any reliable information related to this as there are many factors in an application. We recommend you study the specific material properties of the spring plunger's component parts to make your own calculations, alternatively if in doubt make a test application.

Manufacturing exactly to your specific requirements is also our strength. If you need a variation in spring pressure, plunger body or pin design we can assist with a special design item for volumes as low as 1,000 units.

For further information, or to request a quotation, please call our sales office on 0333 207 4497.