



# One-Touch Fastener - Pull Clamping

push button lock - button handle - stainless steel



## One Touch Fasteners

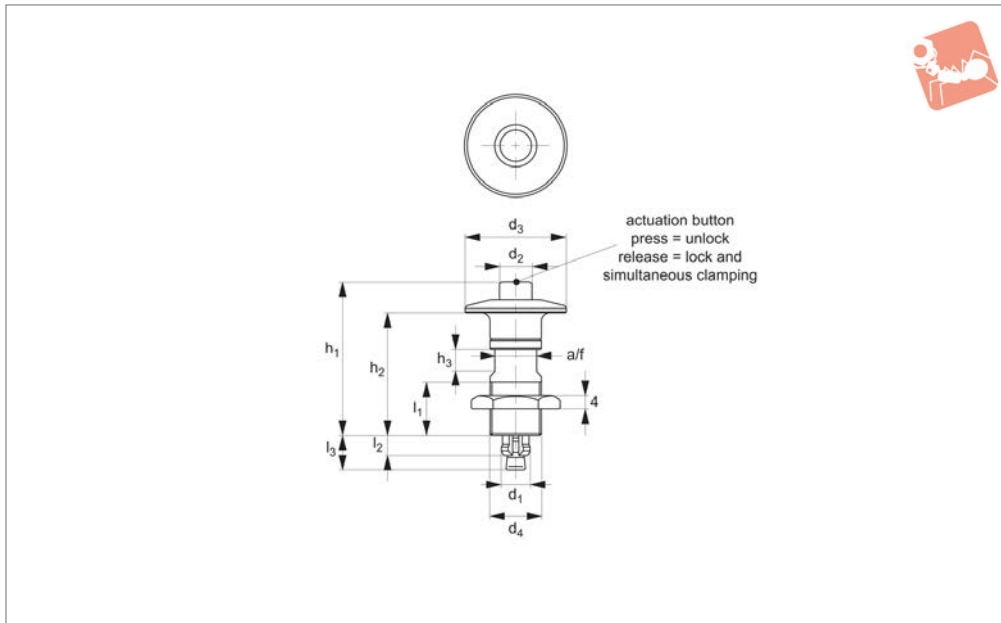

**33964**

ONE TOUCH FASTENERS

### Material

Body: stainless steel SUS 303.  
 Spacer: stainless steel SUS 303.  
 Spring: stainless steel SUS 303.

### Technical Notes

One-touch fasteners are the ideal solution for applications requiring rapid and recurring change over of tooling or set ups. Use in applications as diverse as bottling processes, machine covers, changing of cogs and drive belts. One-touch fasteners provide a quick, simple and secure change over solution - no time waste in unfaste-

ning screws or other permanent fixings, and no opportunity for lost fixings in your machinery.

### Tips

For highly accurate locating, use locating pins 36340 and 36341.

### Important Notes

Suitable for panels/enclosures of 3 to 12 mm.  
 Unique locking and simultaneous clamping.

### Actuation:

- While depressing the actuation button, align pin to receiving hole in frame.
- Once pin is aligned seated in the receiving hole, release button.
- Pin will retract, forcing clamping wedges to spread and pull the two panels together to securely fasten.
- To release, reverse steps described above.

Order No.	Single panel thickness mm	Receiver panel thickness	d <sub>1</sub>	d <sub>2</sub>	d <sub>3</sub>	d <sub>4</sub>	A/F	h <sub>1</sub>	Weight g
<b>33964.W0803</b>	3-8	3	6.5	6.5	23	M12x1	10	40	41
<b>33964.W0806</b>	3-8	6	6.5	6.5	23	M12x1	10	37	40
<b>33964.W1203</b>	3-12	3	8.5	10.0	32	M16x1	14	51	88
<b>33964.W1206</b>	3-12	6	8.5	10.0	32	M16x1	14	48	86

Order No.	h <sub>2</sub>	h <sub>3</sub>	l <sub>1</sub>	l <sub>2</sub>	l <sub>3</sub>	Clamping force N	Shear strength N	Tensile strength N
<b>33964.W0803</b>	32.0	5.5	12.5	6.5	10.5	3	200	150
<b>33964.W0806</b>	29.0	5.5	12.5	9.5	13.5	3	200	150
<b>33964.W1203</b>	41.5	7.0	16.5	6.5	11.0	6	400	300
<b>33964.W1206</b>	38.5	7.0	16.5	9.5	14.0	6	400	300

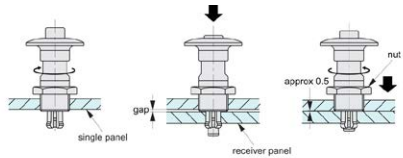

1. screw hole holding clamp into the panel until the end threaded part comes out of the panel
2. insert the clamp pushing the button
3. adjust the clamp until both panels get contacted, then lock the clamp with the nut



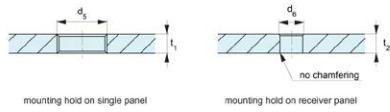

### Operating Principle

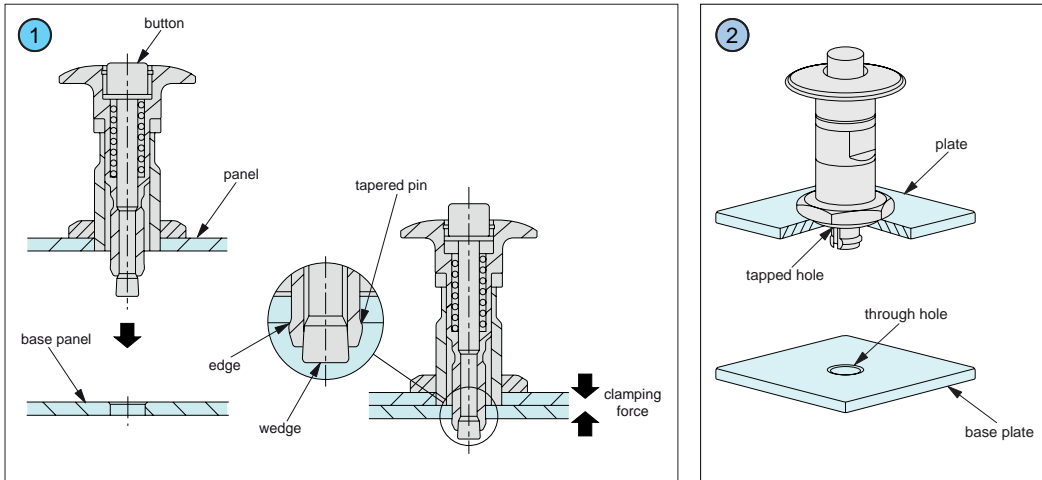

- 1 The tapered pin expanded by the wedge pushes out against the edge of the hole on the base panel, and the two panels are clamped.
- 2 Just a tapped hole and a through hole are required.

### Operating Instructions

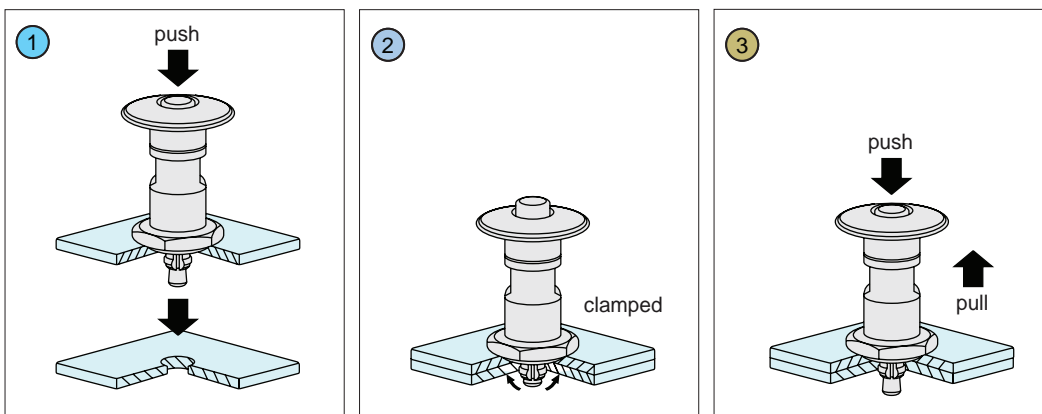

- 1 While depressing the actuation button, align the pin to receiving hole.
- 2 Once pin is aligned and seated in the receiving hole, release button. Pin will retract, forcing clamping wedges to spread and pull the two panels together to securely fasten.
- 3 To release, reverse steps described above.

### Installation Dimensions

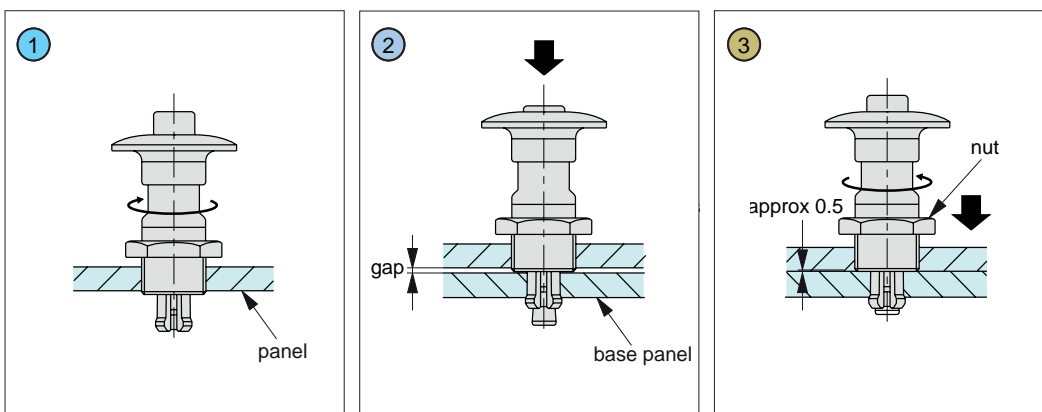

- 1 Screw hole holding clamp into the panel until the end of threaded part comes out of the panel.
- 2 Insert the clamp pushing the button.
- 3 Adjust the clamp until the both panels get contracted and then lock the clamp with the nut.



### Mounting Hole on Panel

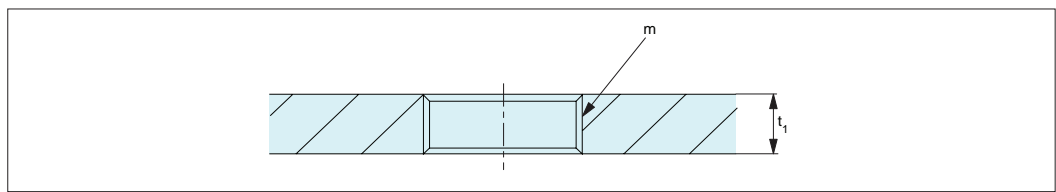

### Mounting Hole on Base Panel

Use hard metals such as stainless steels for the base panel.

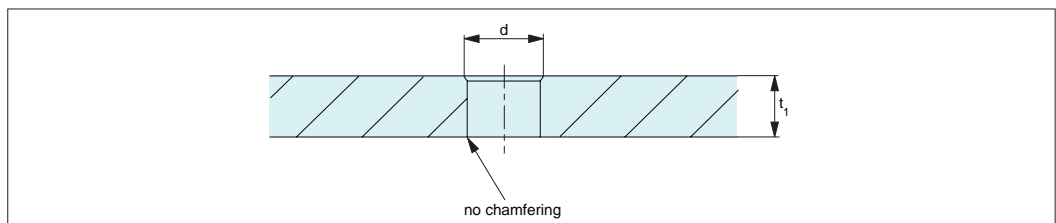

## Applications

### Changes of Holder Panel

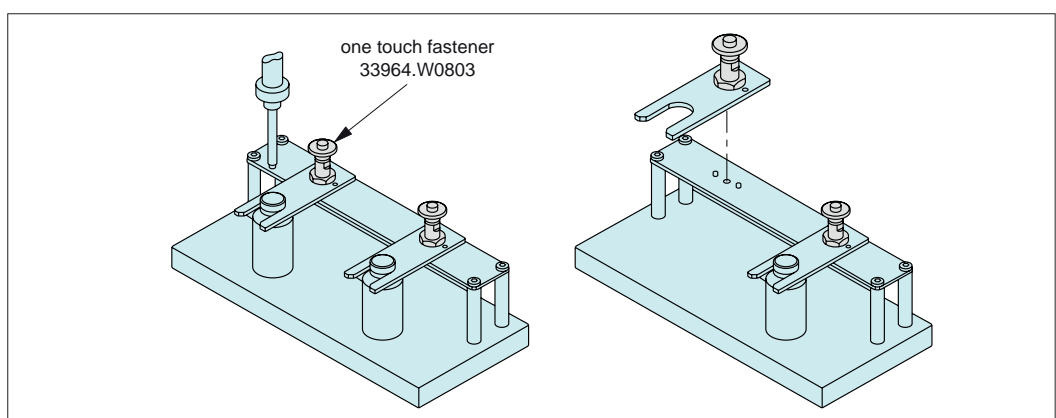

## Installation Best Practice

### Machining Accuracy

Spacing tolerance on both the sub panel and the base panel should be  $\pm 0.1$ .

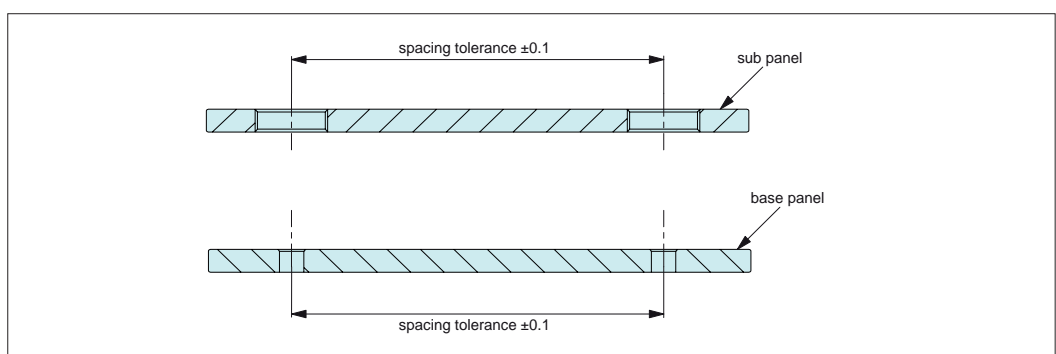

### Repeatability

For highly accurate locating, use locating pins 36340 or 36341. Repeatability of  $\pm 0.25$  is achievable.

