

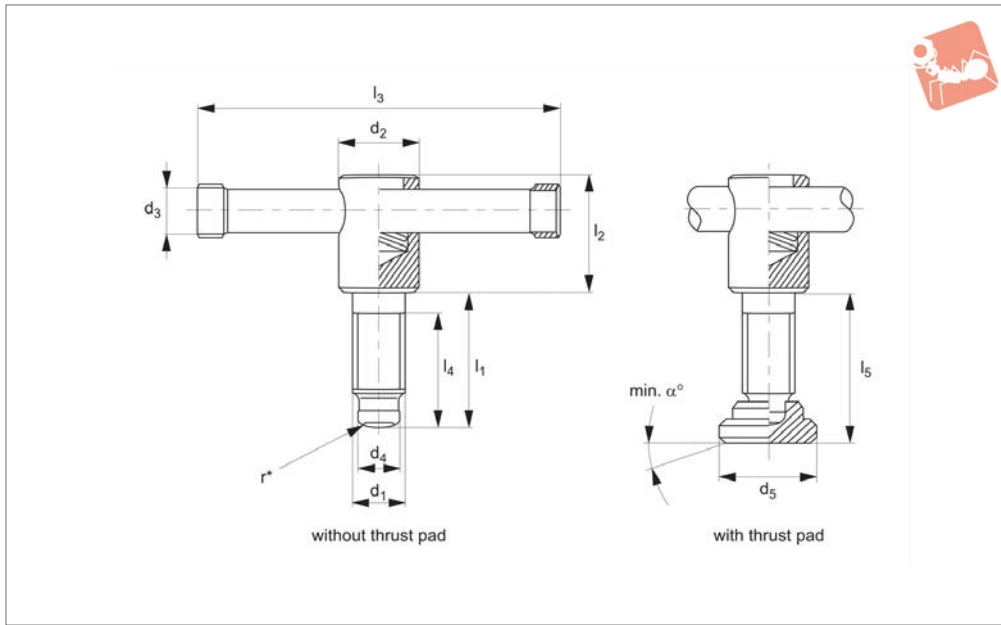

# Tommy Screws with moveable bar - DIN 6306



**38100**

THUMB SCREWS

### Material

Free-cutting steel, black. Turned, pressure lug hardened, with moveable pin retained

by spring.

outside of DIN standard.

### Technical Notes

To ease assembly minor radius ( $r^*$ ) added

Order No.	Thrust pad	$d_1$	$l_1$	$d_2$	$d_3$	$d_4$	$d_5$	$l_2$	$l_3$	$l_4$	$l_5$	$\alpha$	Type	Weight with pad g
38100.W0008	W/o Pad	M 8	40	14	6	6.0	-	25	60	32	-	-	-	41
38100.W0009	W/o Pad	M 8	50	14	6	6.0	-	25	60	42	-	-	-	45
38100.W0010	W/o Pad	M10	40	18	8	8.0	-	32	80	30	-	-	w/o Thrust Pad	91
38100.W0011	W/o Pad	M10	50	18	8	8.0	-	32	80	40	-	-	w/o Thrust Pad	95
38100.W0012	W/o Pad	M12	50	20	10	8.0	-	35	100	40	-	-	w/o Thrust Pad	154
38100.W0013	W/o Pad	M12	60	20	10	8.0	-	35	100	50	-	-	w/o Thrust Pad	161
38100.W0016	W/o Pad	M16	55	24	13	12.0	-	40	120	45	-	-	w/o Thrust Pad	330
38100.W0017	W/o Pad	M16	70	24	13	12.0	-	40	120	60	-	-	w/o Thrust Pad	318
38100.W0018	W/o Pad	M16	90	24	13	12.0	-	40	120	80	-	-	w/o Thrust Pad	345
38100.W0020	W/o Pad	M20	55	30	16	15.5	-	45	140	45	-	-	w/o Thrust Pad	522
38100.W0021	W/o Pad	M20	70	30	16	15.5	-	45	140	60	-	-	w/o Thrust Pad	551
38100.W0022	W/o Pad	M20	90	30	16	15.5	-	45	140	80	-	-	w/o Thrust Pad	593
38100.W0108	With Pad	M 8	40	14	6	6.0	16	25	60	32	43.0	3	-	50
38100.W0109	With Pad	M 8	50	14	6	6.0	16	25	60	42	53.0	3	-	54
38100.W0110	With Pad	M10	40	18	8	8.0	20	32	80	30	43.6	3	With Thrust Pad	110
38100.W0111	With Pad	M10	50	18	8	8.0	20	32	80	40	53.6	3	With Thrust Pad	114
38100.W0112	With Pad	M12	50	20	10	8.0	25	35	100	40	52.6	3	With Thrust Pad	193
38100.W0113	With Pad	M12	60	20	10	8.0	25	35	100	50	64.6	3	With Thrust Pad	198
38100.W0116	With Pad	M16	55	24	13	12.0	32	40	120	45	60.4	5	With Thrust Pad	357
38100.W0117	With Pad	M16	70	24	13	12.0	32	40	120	60	75.4	5	With Thrust Pad	377
38100.W0118	With Pad	M16	90	24	13	12.0	32	40	120	80	95.4	5	With Thrust Pad	402
38100.W0120	With Pad	M20	55	30	16	15.5	40	45	140	45	60.5	4	With Thrust Pad	623
38100.W0121	With Pad	M20	70	30	16	15.5	40	45	140	60	75.5	4	With Thrust Pad	653
38100.W0122	With Pad	M20	90	30	16	15.5	40	45	140	80	95.5	4	With Thrust Pad	693