

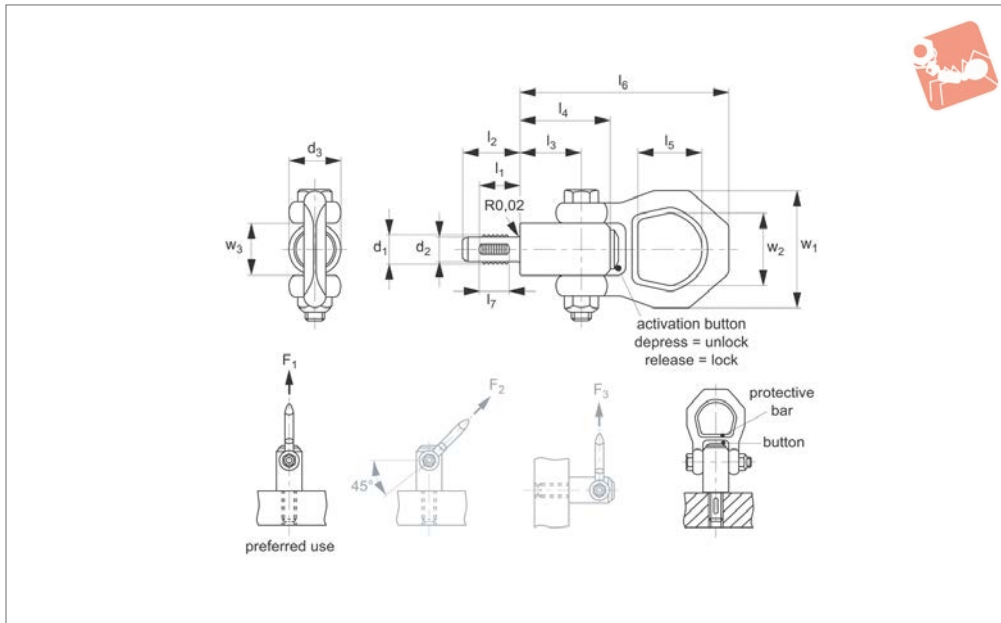

Quick Lift Pins - Threaded inch

Quick Lift Pins



3B430

QUICK LIFT PINS

Material

Steel:

Pin: heat-treated steel, tempered, manganese phosphated.

Threaded element: stainless steel 1.4542, (AISI 630) precipitation hardened.

Shackle: steel, heat-treated, tempered, manganese phosphated.

Press button: aluminium, orange anodised.

Spring: stainless steel.

Stainless steel:

Pin: stainless steel 1.4542, (AISI 630) precipitation hardened.

Threaded element: stainless steel 1.4542, (AISI 630) precipitation hardened.

Shackle: stainless steel 1.45471.

Press button: aluminium, orange anodised.

Spring: stainless steel.

Technical Notes

To suit inch coarse threads, tolerance g6.

CE marked. Both types are corrosion protected. The stainless steel pin is resistant to corrosion and weathering, so suitable for external use.

The instruction manual and CE Declaration of Conformity are included.

F_1^* and F_3^* values are inscribed on the body for reference. F values are calculated on 5 x safety factor.

Depress button: to unlock.

Release button: to lock.

Max temp. 482°F 250°C.

Tips

The pin is ideally used for single point straight up lifts. The bottom face of the pin must be in full contact with the part to be lifted. The pin can also be used with forces F_2 and F_3 after ensuring that the shackle direction is aligned to the direction of the pull. The preferred part for these types of lifts is part 33425, which has a double

swivel function.

Before use: read instruction manual, and data sheets follow standard safe lifting procedures.

Important Notes

The threaded pin must be completely screwed into the thread and tightened to specified tightening torque and bear completely on the bearing surface. Quick and easy to use. The shackle pivots. The protective bar prevents unintentional unlocking by a hook or similar.

Use recommended mainly for direct upwards lift (F_1) as the shackle should be aligned to the direction of lift. Other pins (33425) have a swivel bearing to align shackle.

Rotation of loads must be prevented.

Dimensions in inches

| Order No. | Type | l_1 | d_1 | d_2 inch -0,0028 | d_3 | l_2 | l_3 | l_4 | Weight lb |
|-------------|-----------------|-------|---------|--------------------------|-------|-------|-------|-------|--------------|
| 3B430.W0012 | Steel | 0.67 | 1/2"-13 | 0.42 | 0.85 | 0.95 | 1.01 | 1.42 | 0.5 |
| 3B430.W0020 | Steel | 0.87 | 3/4"-10 | 0.64 | 1.18 | 1.18 | 1.44 | 2.05 | 1.1 |
| 3B430.W0024 | Steel | 1.06 | 1"-8 | 0.86 | 1.42 | 1.42 | 1.65 | 2.36 | 2.6 |
| 3B430.W1012 | Stainless Steel | 0.67 | 1/2"-13 | 0.42 | 0.85 | 0.95 | 1.01 | 1.42 | 0.5 |
| 3B430.W1020 | Stainless Steel | 0.87 | 3/4"-10 | 0.64 | 1.18 | 1.18 | 1.44 | 2.05 | 1.1 |
| 3B430.W1024 | Stainless Steel | 1.06 | 1"-8 | 0.86 | 1.42 | 1.42 | 1.65 | 2.36 | 2.7 |

| Order No. | l_5 | l_6 | l_7 | w_1 | w_2 | w_3 | F_1 lbf | F_2 lbf | F_3 lbf | Locating thread |
|-------------|-------|-------|-------|-------|-------|-------|--------------|--------------|--------------|-----------------|
| 3B430.W0012 | 1.06 | 3.45 | 0.47 | 1.93 | 1.18 | 0.85 | 1528 | 764 | 607 | 1/2"-13 |
| 3B430.W0020 | 1.28 | 4.49 | 0.67 | 2.21 | 1.42 | 1.18 | 3619 | 1731 | 1281 | 3/4"-10 |
| 3B430.W0024 | 1.99 | 5.98 | 0.87 | 3.23 | 1.96 | 1.42 | 6766 | 3147 | 2225 | 1"-8 |

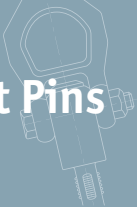

| Order No. | l_5 | l_6 | l_7 | w_1 | w_2 | w_3 | F_1 lbf | F_2 lbf | F_3 lbf | Locating thread |
|--------------------|-------|-------|-------|-------|-------|-------|--------------|--------------|--------------|-----------------|
| 3B430.W1012 | 1.06 | 3.45 | 0.47 | 1.93 | 1.18 | 0.85 | 1528 | 764 | 607 | 1/2"-13 |
| 3B430.W1020 | 1.28 | 4.49 | 0.67 | 2.21 | 1.42 | 1.18 | 3619 | 1731 | 1281 | 3/4"-10 |
| 3B430.W1024 | 1.99 | 5.98 | 0.87 | 3.23 | 1.96 | 1.42 | 6766 | 3147 | 2225 | 1"-8 |

QUICK LIFT PINS

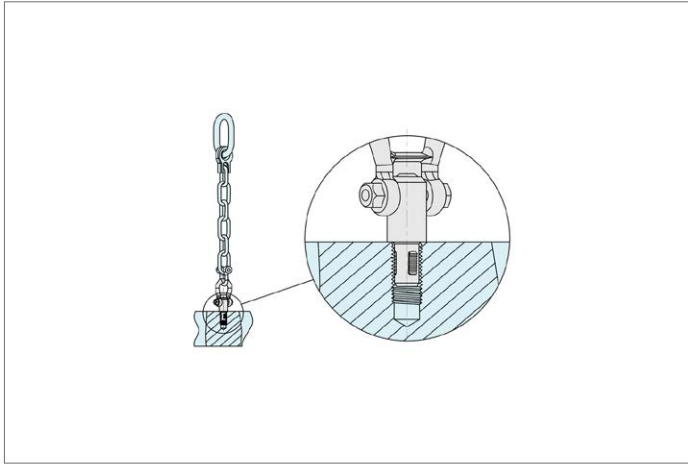



Danger!

Self-locking quick lift pins are designed to lift and hold point loads not people.

Self-locking quick lift pins are not suited for rotating loads.

Dirt and debris etc can affect the performance of the pins.

Using damaged self-locking pins can be very dangerous. Before each use carefully inspect the pins (damage, deformities, signs of stress, corrosion, check unlocking and locking function, loss of balls etc. Check full movement of shackle. Withdraw any defective pins from service immediately.

To release the balls, press button A. To lock the balls, release button A.

The load figures F_1 , F_2 and F_3 apply only to lifting applications used with a steel retainer, and an "x" min of 1.5mm.

Inspect before and after every use. For maintenance – take the out of service after 12 months for inspection by qualified personnel.

- Ensure all lifting pins are CE marked.
- Ensure they are handled by qualified personnel.
- Refer to the operating instructions particularly with regards to product selection, any possibility of the load swivelling, the effect of lifting angles on the load capacity (see relevant tables), etc.
- Never allow any personnel underneath a suspended load.
- Always heed the load rating of the lifting pin.
- Always perform a visual inspection of the lifting pins prior to use. Checking for any damage to thread and/or swivelling system. Check for wear or corrosion, signs of stress or bending.
- Ensure a yearly full service inspection is performed.
- Always ensure the full bottom face of the lifting pin shoulder is in contact with a smooth, square surface.
- Ensure full and unrestricted movement of the lifting pin in all directions.
- Before each lift ensure the correct orientation of the shackle in the lift direction.
- Avoid using our standard steel lifting pins in corrosive environments eg. sandy, chemical, acid, moisture etc. In this case consider using our stainless steel lifting pins (33420).

Operating Instructions 33400 and 33420

Note: The full shaft must be engaged. Longer shaft lengths can be supplied on request or a bolt and washer/nut combination can be used.

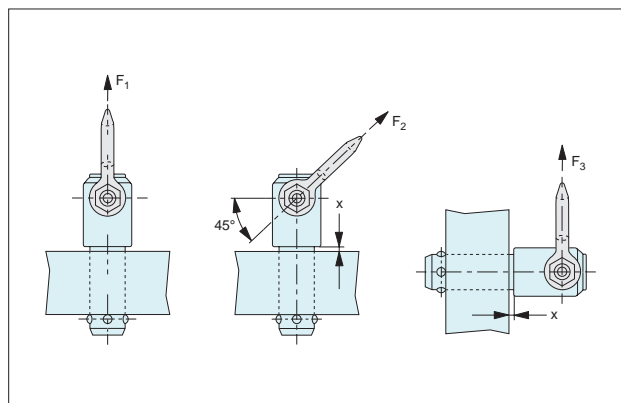
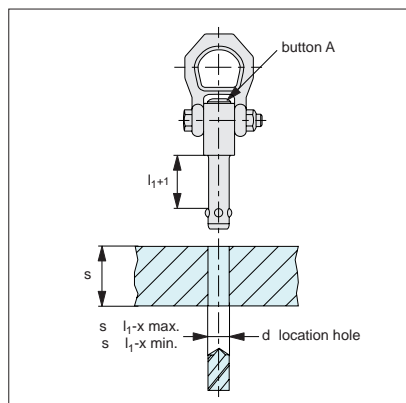

Notes

**Danger!**

Self-locking quick lift pins are designed to lift and hold point loads not people.

Self-locking quick lift pins are not suited for rotating loads.

Dirt and debris etc can affect the performance of the pins.

Using damaged self-locking pins can be very dangerous. Before each use carefully inspect the pins (damage, deformities, signs of stress, corrosion, check unlocking and locking function, loss of balls etc. Check full movement of shackle. Withdraw any defective pins from service immediately.

To release the balls, press button A. To lock the balls, release button A.

The load figures F_1 , F_2 and F_3 apply only to lifting applications used with a steel retainer, and an "x" min of 1.5mm.

Inspect before and after every use. For maintenance – take the out of service after 12 months for inspection by qualified personnel.

Operating Instructions 33400 and 33420

Note: The full shaft must be engaged. Longer shaft lengths can be supplied on request or a bolt and washer/nut combination can be used.

- Ensure all lifting pins are CE marked.
- Ensure they are handled by qualified personnel.
- Refer to the operating instructions particularly with regards to product selection, any possibility of the load swivelling, the effect of lifting angles on the load capacity (see relevant tables), etc.
- Never allow any personnel underneath a suspended load.
- Always heed the load rating of the lifting pin.
- Always perform a visual inspection of the lifting pins prior to use. Checking for any damage to thread and/or swivelling system. Check for wear or corrosion, signs of stress or bending.
- Ensure a yearly full service inspection is performed.
- Always ensure the full bottom face of the lifting pin shoulder is in contact with a smooth, square surface.
- Ensure full and unrestricted movement of the lifting pin in all directions.
- Before each lift ensure the correct orientation of the shackle in the lift direction.
- Avoid using our standard steel lifting pins in corrosive environments eg. sandy, chemical, acid, moisture etc. In this case consider using our stainless steel lifting pins (33420).

Notes