

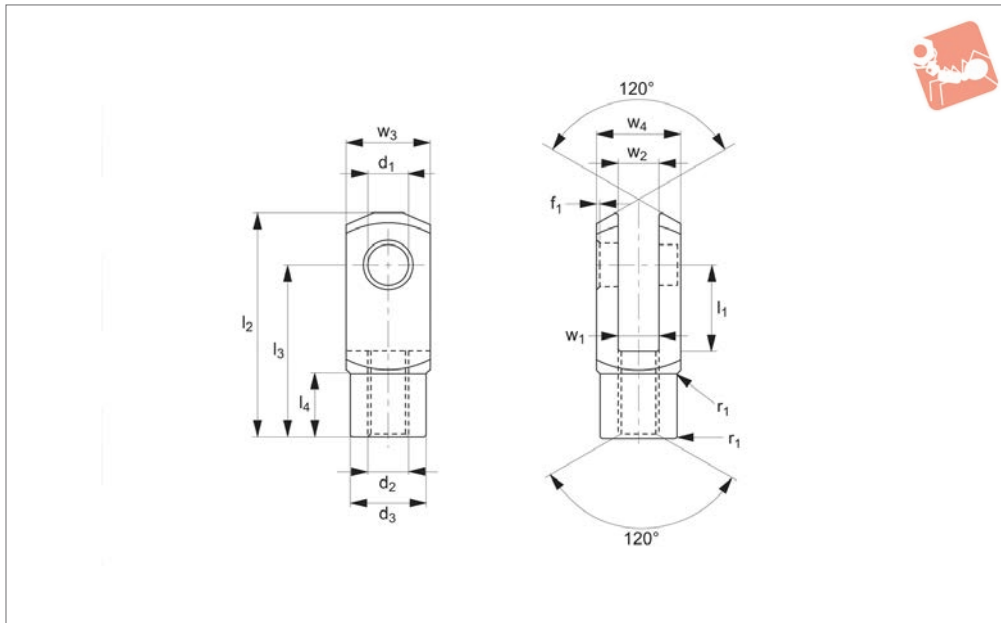

Stainless Clevis Joints with Pin

left hand thread

Clevis Joints



65616

CLEVIS JOINTS

Material

Stainless steel (1.4305 AISI 303 X8CrNiS18-9)

Technical Notes

M5-M16: DIN 71 752/DIN ISO 8140.
M20: Similar to DIN 71 752 and according to CETOP standard.

Tips

Assembly is made up using 65636 clevis

joint, 65666 pin, and 2 off 65678 circlips.

Important Notes

For sizes M5-M12, f_1 and $r_1 = 0,5$, for sizes M16, f_1 and $r_1 = 1$
For size M20, $f_1=1$, $r_1 = 1,5$, for r_1 , radius or 45° bevelling.
Other Tolerances:-
 w_4 : M4-M16 = +0,3 -0,16
M20 = +0,5 - 0,2

w_2 : Size 4x8-10x20 = B13
Size 10x40-20x40 = +0,7 +0,15
 l_3 : up to size 6x12 = ±0,3
From size 6x24 = ±0,4

Order No.	Size	Thread hand	Thread type	d_1 tol. H9	l_1 ±0.5	d_2	d_3	l_2 ±0.5	l_3	l_4	w_1 tol. B13	w_2	w_3 tol. h11	w_4	Weight g
65616.W0051	5x10	Left	Coarse	5	10	M5	9	26	20	7.5	5	5	10	10	9
65616.W0052	5x20	Left	Coarse	5	20	M5	9	36	30	7.5	5	5	10	10	13
65616.W0061	6x12	Left	Coarse	6	12	M6	10	31	24	9.0	6	6	12	12	15
65616.W0062	6x24	Left	Coarse	6	24	M6	10	43	36	9.0	6	6	12	12	21
65616.W0081	8x16	Left	Coarse	8	16	M8	14	42	32	12.0	8	8	16	16	37
65616.W0082	8x16	Left	Fine	8	16	M8x1	14	42	32	12.0	8	8	16	16	37
65616.W0083	8x32	Left	Coarse	8	32	M8	14	58	48	12.0	8	8	16	16	54
65616.W0084	8x32	Left	Fine	8	32	M8x1	14	58	48	12.0	8	8	16	16	54
65616.W0102	10x20	Left	Coarse	10	20	M10	18	52	40	15.0	10	10	20	20	74
65616.W0103	10x20	Left	Fine	10	20	M10x1,25	18	52	40	15.0	10	10	20	20	74
65616.W0104	10x40	Left	Coarse	10	40	M10	18	72	60	15.0	10	10	20	20	116
65616.W0105	10x40	Left	Fine	10	40	M10x1,25	18	72	60	15.0	10	10	20	20	116
65616.W0122	12x24	Left	Coarse	12	24	M12	20	62	48	18.0	12	12	24	24	121
65616.W0123	12x24	Left	Fine	12	24	M12x1,25	20	62	48	18.0	12	12	24	24	121
65616.W0124	12x48	Left	Coarse	12	48	M12	20	86	72	18.0	12	12	24	24	175
65616.W0125	12x48	Left	Fine	12	48	M12x1,25	20	86	72	18.0	12	12	24	24	175
65616.W0163	16x32	Left	Coarse	16	32	M16	26	83	64	24.0	16	16	32	32	282
65616.W0164	16x32	Left	Fine	16	32	M16x1,5	26	83	64	24.0	16	16	32	32	282
65616.W0166	16x64	Left	Coarse	16	64	M16	26	115	96	24.0	16	16	32	32	411
65616.W0167	16x64	Left	Fine	16	64	M16x1,5	26	115	96	24.0	16	16	32	32	411
65616.W0204	20x40	Left	Coarse	20	40	M20	34	105	80	30.0	20	20	40	40	550
65616.W0205	20x40	Left	Fine	20	40	M20x1,5	34	105	80	30.0	20	20	40	40	550

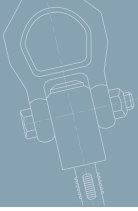

Parts overview

CLEVIS JOINTS

Clevis Joints

Stocked to DIN 71752 in steel and stainless steel. Plain clevis joints available in right and left hand threads zinc plated steel and stainless steel. Steel sizes from M4 up to M48. Stainless sizes from M4 up to M27.



Clevis Mating Pieces

These are designed to fit in between our clevis joints to create a linkage where an angular offset is required. Available in zinc plated steel and stainless steel. Sizes M4 up to M20.



Clevis Pins and Clips

Various styles of pins and clips to suit clevis joints in zinc plated steel and stainless steel. Sizes available to suit all sizes of clevis joints that we offer.



Clevis Retention Clips

These are the most popular type of clip used with our clevis joints. They create a neat compact assembly, only available in zinc plated steel. Size available for clevis joints from 4mm up to 20mm.



Male Clevis Joints

Stocked in zinc plated steel and stainless steel, right and left hand threads. Sizes M6 up to M20.





Clevis with retention clip
65630 and 65684



Clevis with clevis pin, washer and cotter pin
65660 and 65674



Zinc plated steel

Clevis with clevis pin 65664
Safety fastener 65680

Clevis with clevis pin and circlips 65666 and 65678



Clevis with clevis pin, washer and cotter pin 65661 and 65675



Stainless steel

Clevis with 65652 mating piece and 65684 clevis retention clip



Clevis with 65880 rod end and 65684 clevis retention clip



Assembly options

Tensile tests, statistically to failure (break)

Clevis joints axially loaded.

Leaded low carbon steel (AISI 12L14, 1.0718).

Clevises M6 - M42

Material

Clevis size	F min (kN)	F max (kN)	F average value (kN)	Avg. force when clevis starts to deform (kN)
6 x 24 M 6	16,0	19,5	17,6	15,3
8 x 32 M 8	33,2	35,6	34,6	29,3
10 x 40 M10	42,0	52,0	47,5	41,3
12 x 48 M12	53,0	68,5	61,1	50,2
14 x 56 M14	60,5	64,5	63,0	48,8
16 x 64 M16	133,5	146,0	140,2	115
20 x 40 M20	194,5	234,0	213,5	176
25 x 50 M25	311,0	336,0	328,0	260
30 x 60 M30	428,0	450,0	440,6	343
36 x 72 M36	566,0	573,0	569,5	300
35 x 72 M36	561,2	567,9	564,6	370
42 x 84 M42	904,6	904,6	904,6	420

Important note: values in this table are indicative only and should only be used as a rough guide. The Company cannot foresee the intended applications of their products and we accept no liability for any actions taken by third parties. Customers are advised to use their own safety factors and/or perform their own testing on the clevis joint to ensure it meets requirements for their application.