

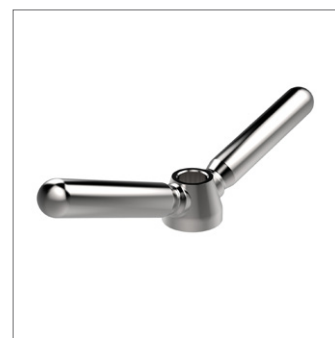

Clamping Nuts welded, double-sided

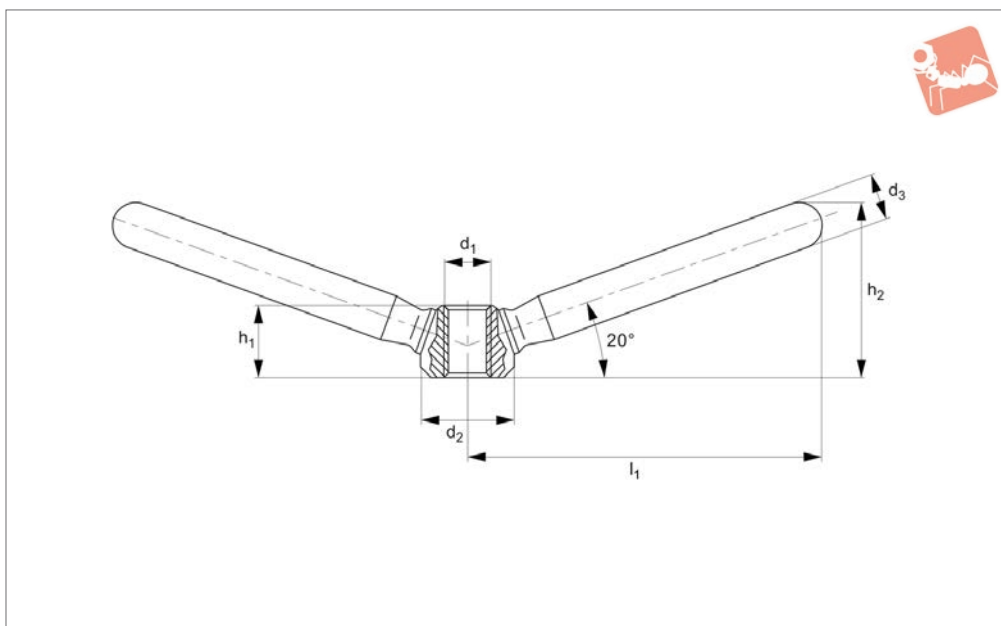

73922

CLAMPING LEVERS

Material

Steel, galvanised.
Stainless steel 1.4301, dull blasted.

Technical Notes

Allows for two-handed operating.

Order No.	Material	d ₁	d ₂	d ₃	h ₁	h ₂	l ₁ ≈	Weight g
73922.W0706	Steel	M 8	16	10	12.5	26	47.5	55
73922.W0708	Steel	M10	20	12	15.0	32	59.5	116
73922.W0710	Steel	M12	25	14	19.0	40	75.5	210
73922.W0712	Steel	M16	32	18	25.0	52	94.5	432
73922.W0716	Steel	M20	40	20	31.0	62	118.0	716
73922.W0806	Stainless Steel	M 8	16	10	12.5	26	47.5	55
73922.W0808	Stainless Steel	M10	20	12	15.0	32	59.5	116
73922.W0810	Stainless Steel	M12	25	14	19.0	40	75.5	210
73922.W0812	Stainless Steel	M16	32	18	25.0	52	94.5	432
73922.W0816	Stainless Steel	M20	40	20	31.0	62	118.0	716