

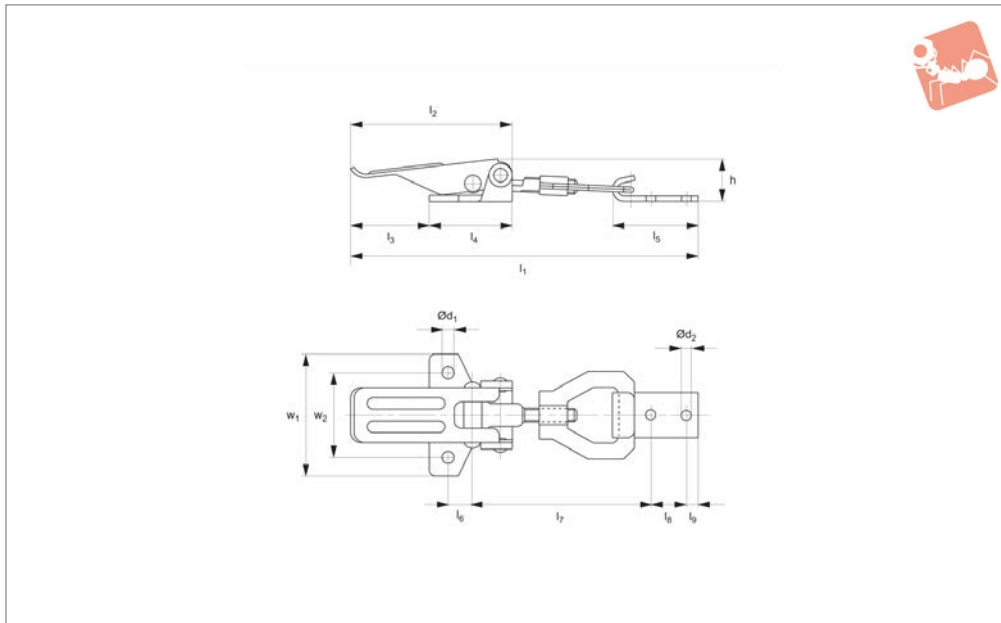

Toggle Latches

adjustable, stainless steel

Draw Latches

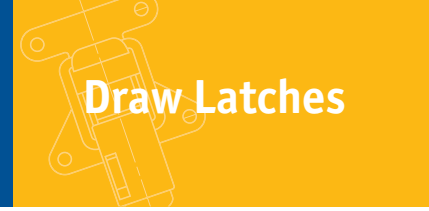

J0520

DRAW LATCHES

Material

Steel, Fe P02 + P12, UNI5866, zinc plated.
Or stainless steel AISI 304, UNI x5crNi.

Technical Notes

Supplied with counter strike.
Draw length adjustable through turns of

threaded draw rod, giving 12mm length of adjustment.

Order No.	Finish	l_1	h	w_1	$\varnothing d_1$	$\varnothing d_2$	l_2	l_3	l_4	Weight g
J0520.AC0004	Zinc Plated Steel	138 to 150	18	52	5.2	4.1	67.5	33	35	110
J0520.AC0030	Stainless Steel	138 to 150	18	52	5.2	4.1	67.5	33	35	110

Order No.	l_5	l_6	l_7	l_8	l_9	Load N max.	Tension N max.	w_2	w_3
J0520.AC0004	36	10	68 to 80	15	5	1100	2500	36	19
J0520.AC0030	36	10	68 to 80	15	5	1100	2500	36	19



J0560

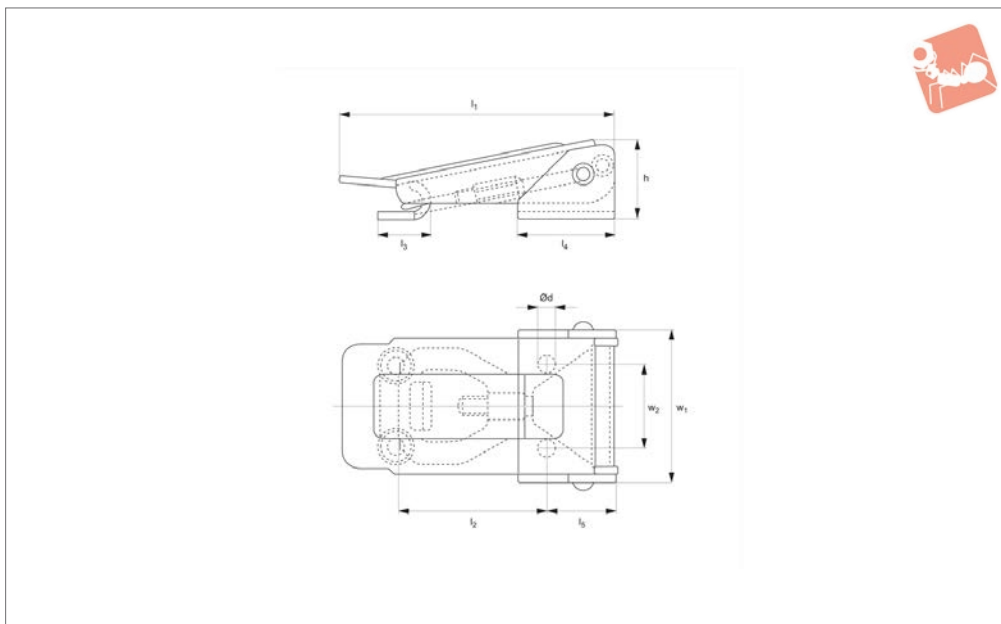

Material

Steel, Fe P02 + P12, UNI5866, zinc plated.
Or stainless steel AISI 304, UNI x5crNi.

Technical Notes

Supplied with counter strike.
Draw length adjustable through turns of

threaded draw rod, giving 12mm length of adjustment.

Order No.	Finish	l_1	h	w_1	$\varnothing d$	l_2	Weight g
J0560.AC0004	Zinc Plated Steel	88	26	48.5	5.5	48 to 60	160
J0560.AC0030	Stainless Steel	88	26	48.5	5.5	48 to 60	160

Order No.	l_3	l_4	l_5	Load N max.	Tension N max.	w_2
J0560.AC0004	17	31	22	1500	3000	26
J0560.AC0030	17	31	22	1500	3000	26

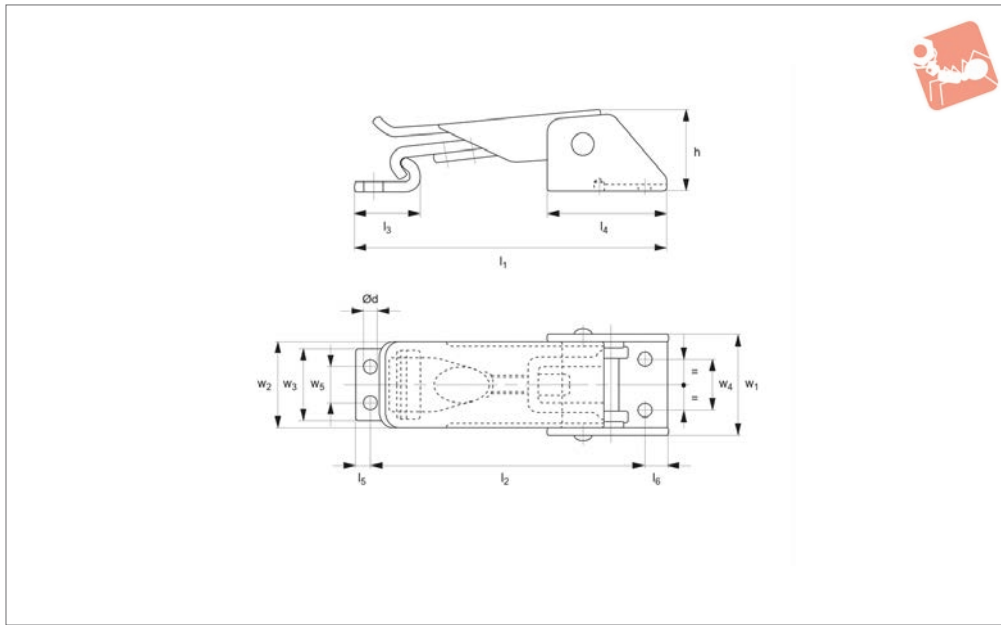

J0580

DRAW LATCHES

Material

Steel, Fe P02 + P12, UNI5866, nickel plated.

Technical Notes

Supplied with counter strike.
Draw length adjustable through turns of

threaded draw rod, giving 12mm length of adjustment.

Order No.	Finish	l_1	h	w_1	$\varnothing d$	l_2	l_3	l_4	Weight g
J0580.AC0001	Nickel plated steel	82 to 94	22	27	3.6	72 to 84	17.5	33	100
Order No.	l_5	l_6	Load N max.	Tension N max.	w_2	w_3	w_4	w_5	
J0580.AC0001	4	6	1000	2000	24	19	14	10	



J0600

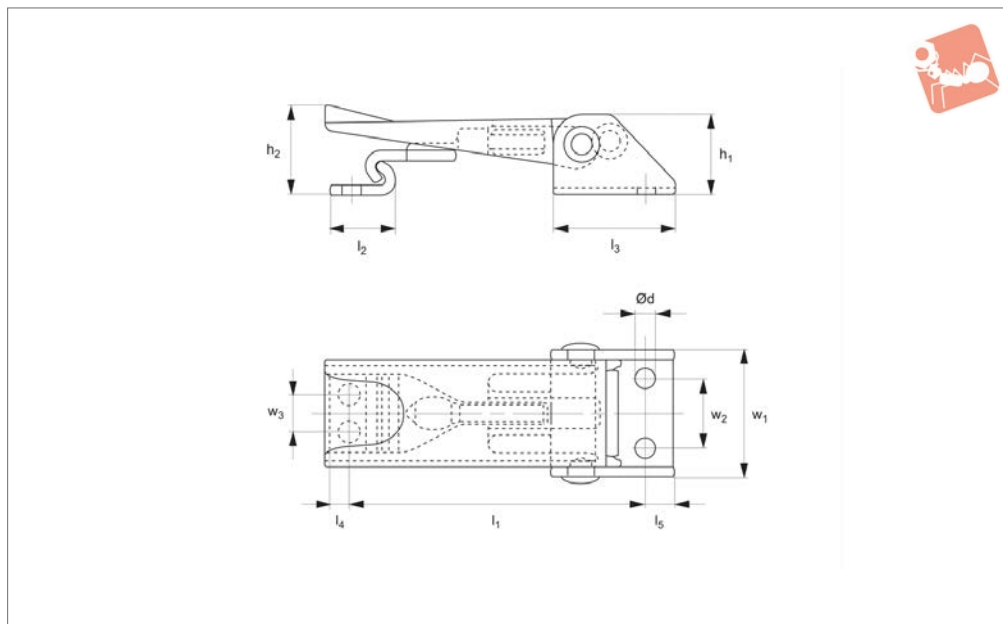

Material

Steel, Fe P02 + P12, UNI5866, zinc plated.
Or stainless steel AISI 304, UNI x5crNi.

Technical Notes

Supplied with counter strike.
Draw length adjustable through turns of

threaded draw rod, giving 10mm length of adjustment.

Order No.	Finish	l_1	h_1	w_1	$\varnothing d$	h_2	Weight g
J0600.AC0008	Zinc Plated	60 to 70	16	25.5	4.2	18	55
J0600.AC0030	Stainless Steel	60 to 70	16	25.5	4.2	18	55

Order No.	l_2	l_3	l_4	l_5	Load N max.	Tension N max.	w_2	w_3
J0600.AC0008	14	25	4	6	1000	1400	14	8
J0600.AC0030	14	25	4	6	1000	1400	14	8