

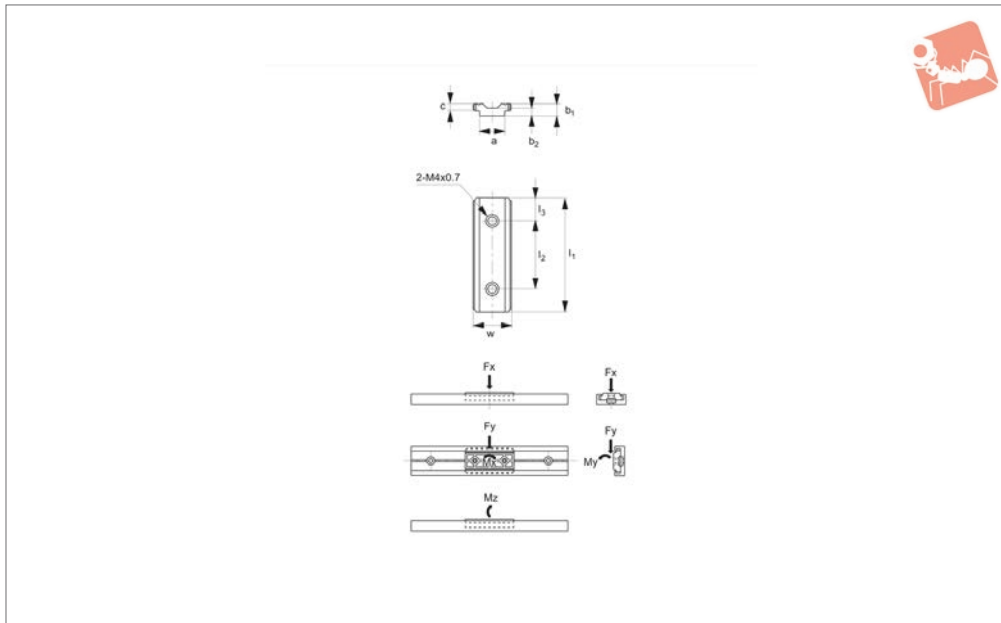

# Mini Slide Carriage

for use with mini slide rail P0350

## Linear Slides



**P0300**

LINEAR SLIDES

### Material

Body: special low friction polyethylene.  
Insert nut: stainless steel, AISI 302.

### Technical Notes

Compact design for wide range of small stroke applications.  
Provides outstanding performance with lighter movement than ball-bearing slides.  
Material values:

- Coefficient of friction  $\mu$  0.15
- Coefficient of dynamic friction  $\mu$  0.10
- Limited PV value 3Mpa.m/min  
 $p_v = p$  (pressure Mpa) x  $V$  (slide speed m/min)
- $p = 0.74$  Mpa
- $V = 12$  m/min.

### Important Notes

Dynamic and static loads provided as a

### guide, please apply following reduction factors for application conditions:

- Low speed/low operation frequency = use 70 to 90% of load rating.
- Moderate speed/high operation frequency = use 35 to 65% of load rating.
- High operation frequency with vibration = use 10 to 30% of load rating.

Order No.	Size	Type	a	b <sub>1</sub>	b <sub>2</sub>	c	w	l <sub>1</sub>	l <sub>2</sub>	l <sub>3</sub>	Weight g
P0300.AC0020	20	Carriage	11.2	5.2	3.5	2.7	16.8	50	30	10	7
P0300.AC0050	30	Carriage	18.0	7.0	-	4.3	25.8	50	30	10	7

Order No.	Horiz. static load f <sub>x</sub> kg/f	Vert. static load f <sub>y</sub> kg/f	Vert. dynm. load m <sub>x</sub> kg/f	Horiz. dynm. load m <sub>y</sub> kg/f	Horiz. dynm. load m <sub>z</sub> kg/f
P0300.AC0020	30.6	17.8	-	-	-
P0300.AC0050	26.0	15.0	25.0	12.5	12.5

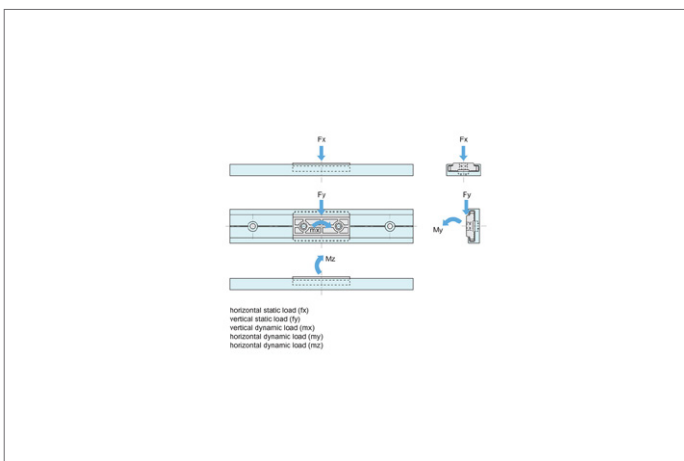



## P0350

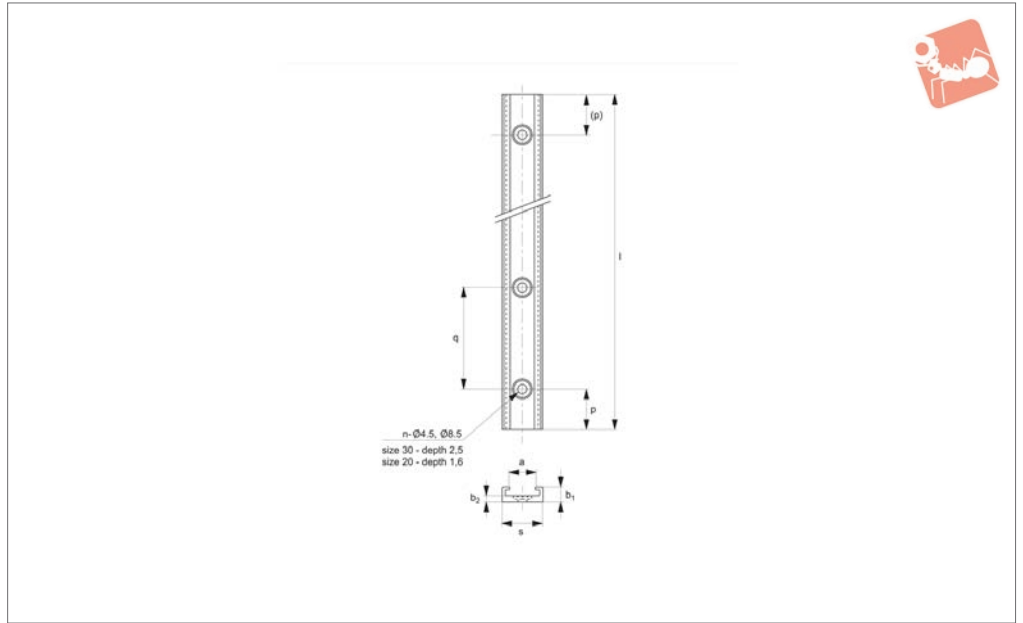

### Material

Aluminium, anodized (except ends).

protection against corrosion.

### Technical Notes

9-micron anodized film provides excellent

Compact design used in conjunction with mini-slide carriage P0300, suitable for wide variety of applications.

Order No.	Size	Type	l	p	No. of holes in slide length	s	a	b <sub>1</sub>	b <sub>2</sub>	q	Weight g
P0350.AC0010	30	Rail	100	10	3	30	19.8	10.0	3.88	40	39
P0350.AC0020	30	Rail	200	20	5	30	19.8	10.0	3.88	40	79
P0350.AC0040	30	Rail	400	20	10	30	19.8	10.0	3.88	40	159
P0350.AC0080	30	Rail	800	20	20	30	19.8	10.0	3.88	40	312
P0350.AC0200	30	Rail	2000	20	50	30	19.8	10.0	3.88	40	790
P0350.AC0012	20	Rail	100	25	2	20	11.2	8.2	2.88	50	20
P0350.AC0022	20	Rail	200	25	4	20	11.2	8.2	2.88	50	40
P0350.AC0042	20	Rail	400	25	8	20	11.2	8.2	2.88	50	80
P0350.AC0082	20	Rail	800	25	16	20	11.2	8.2	2.88	50	160
P0350.AC0202	20	Rail	2000	25	40	20	11.2	8.2	2.88	50	400

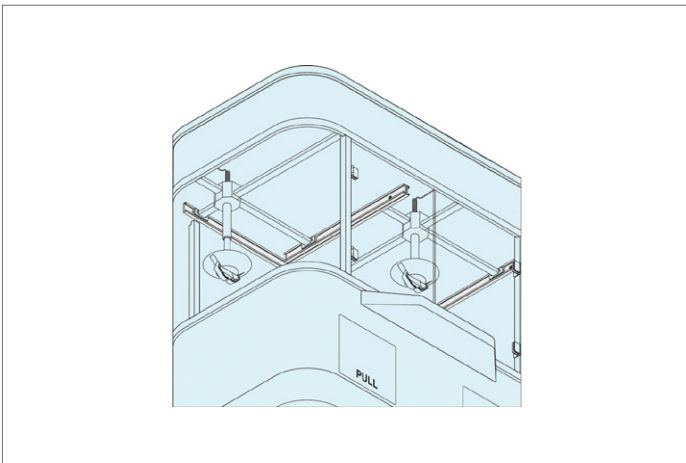



### Load ratings

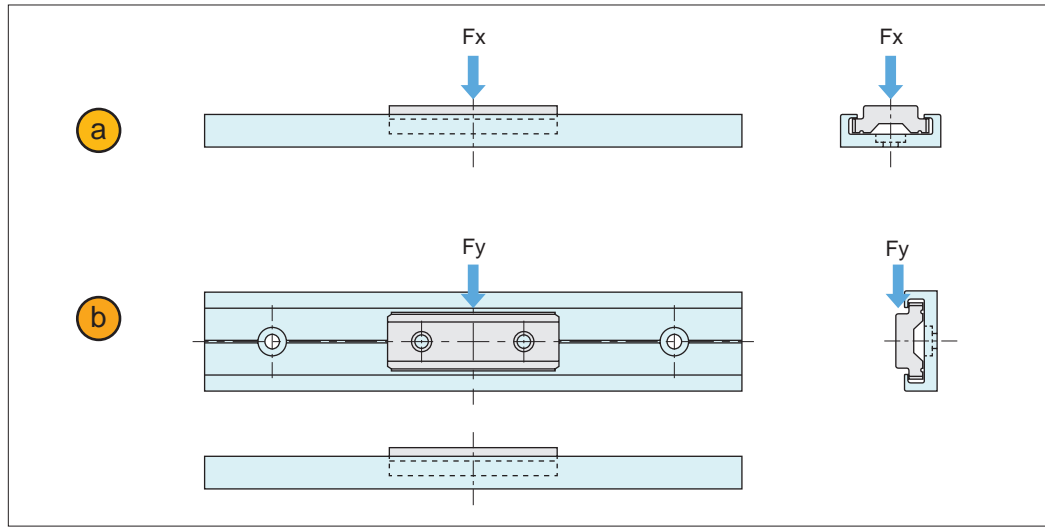

#### Load rating for mini slider P0300.AC0020 (size 20)

Material values  
 Coefficient of friction  $\mu$  0.15  
 Coefficient of dynamic friction  $\mu_s$  0.10  
 Limited PV value 3 Mpa.m/min  
 $PV = p$  (pressure Mpa)  $\times$   $V$  (slide speed m/min)  
 $p = 0.74$  Mpa  
 $V = 12$  m/min

<b>a</b> Horizontal static load $F_x$	30.6 kgf (67.5 lbs)
<b>b</b> Vertical static load $F_y$	17.8 kgf (39.2 lbs)

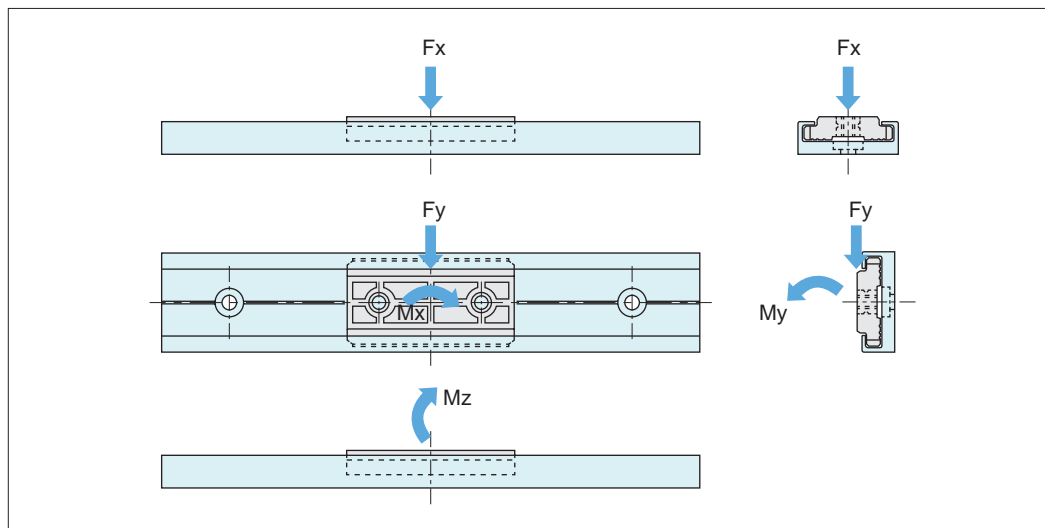

#### Load rating for mini slider P0300.AC0050 (size 30)

Horizontal static load $F_x$	26 kgf (57.2 lbs)
Vertical static load $F_y$	15 kgf (33 lbs)
Vertical dynamic load $M_x$	25 kgf · cm (21.6 lbs · in)
Horizontal dynamic load $M_y$	12.5 kgf · cm (10.8 lbs · in)
Horizontal dynamic load $M_z$	12.5 kgf · cm (10.8 lbs · in)

**Important Note: Dynamic and static loads provided as a guide, please apply following reduction factors for application conditions:**

**Low speed/low operation frequency = use 70 to 90% of load rating.**

**Moderate speed/high operation frequency = use 35 to 65% of load rating.**

**High operation frequency with vibration = use 10 to 30% of load rating.**