



Spring Plungers

smooth model, with collar and ball- stainless steel



Spring Plunger & Detent Pins

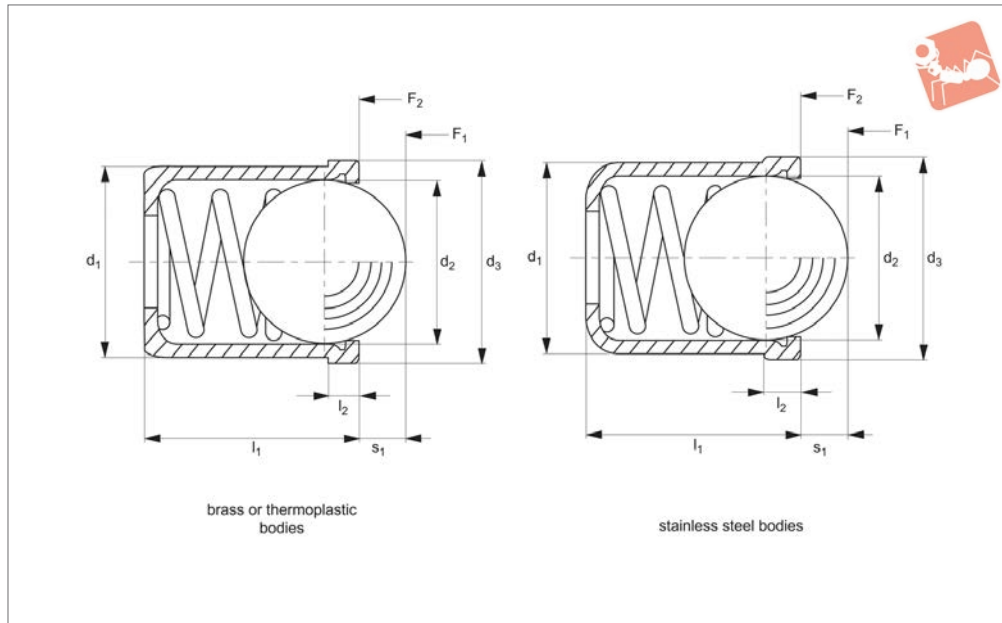

32300

SPRING PLUNGER & DETENT PINS

Material

Body: stainless steel 1.4303 (AISI 305), brass, or thermoplastic POM, blue.
 Ball: ball bearing steel 1.3505 (100Cr6) hardened or thermoplastic POM, white.
 Spring: stainless steel 1.4568 (X7CrNiAl17-7).

Technical Notes

Used for locating, applying pressure or

lifting off.

Spring loads * = statistical average values.
 Thermo type temperature range -30°C to +50°C.
 Stainless and brass type, temperature range max. 250°C.
 For calculation of indexing resistance please refer to spring plunger technical pages.

Tips

These are press fit spring plungers. Typical hole tolerance is H7 for manual assembly. These fit tolerances vary with type of material so a trial hole is recommended. Light spring load- marked with one line. Standard spring load- no marking. Heavy spring load- marked with two lines. Special types available on request.

Order No.	Spring load	Finish	d ₁ -0 +0.1	d ₂	d ₃	l ₁	l ₂ ≈	s ₁	Spring load	Spring load	Temperature °C max.	Weight g
									F ₁ N ≈	F ₂ N ≈		
32300.W1004	Light	Body & Ball Stainless	4	3,00	4,6	5,0	0,90	1,00	0,4	1,0	250	0,30
32300.W1005	Light	Body & Ball Stainless	5	4,00	5,6	6,0	0,90	1,40	0,5	4,7	250	0,60
32300.W1006	Light	Body & Ball Stainless	6	5,00	6,5	7,0	1,00	1,80	2,3	6,5	250	1,00
32300.W1008	Light	Body & Ball Stainless	8	6,50	8,5	9,0	1,10	2,40	4,0	9,0	250	2,10
32300.W1010	Light	Body & Ball Stainless	10	8,50	11,0	13,0	1,50	3,30	3,9	10,0	250	4,40
32300.W1012	Light	Body & Ball Stainless	12	10,00	13,0	16,0	2,30	4,00	6,2	14,6	250	7,30
32300.W0003	Standard	Body & Ball Stainless	3	2,38	3,5	4,0	0,60	0,70	1,8	3,5	+250	0,20
32300.W0004	Standard	Body & Ball Stainless	4	3,00	4,6	5,0	0,90	1,00	2,5	6,0	+250	0,30
32300.W0005	Standard	Body & Ball Stainless	5	4,00	5,6	6,0	0,90	1,40	3,0	6,5	+250	0,60
32300.W0006	Standard	Body & Ball Stainless	6	5,00	6,5	7,0	1,00	1,80	5,5	11,5	+250	1,00
32300.W0008	Standard	Body & Ball Stainless	8	6,50	8,5	9,0	1,10	2,40	7,0	12,5	+250	2,10
32300.W0010	Standard	Body & Ball Stainless	10	8,50	11,0	13,0	1,50	3,30	8,5	18,5	+250	4,40
32300.W0012	Standard	Body & Ball Stainless	12	10,00	13,0	16,0	2,30	4,00	12,0	26,5	+250	7,30
32300.W0203	Standard	Body Brass, Ball Stainless	3	2,38	3,6	4,0	0,60	0,60	1,8	3,5	+250	0,20
32300.W0204	Standard	Body Brass, Ball Stainless	4	3,00	4,5	5,0	1,00	0,80	3,0	6,0	+250	0,50
32300.W0205	Standard	Body Brass, Ball Stainless	5	4,00	5,5	6,0	1,00	1,00	4,0	6,5	+250	0,80
32300.W0206	Standard	Body Brass, Ball Stainless	6	5,00	6,5	7,0	1,00	1,60	6,0	11,5	+250	1,30
32300.W0208	Standard	Body Brass, Ball Stainless	8	6,50	8,5	9,0	1,00	1,90	8,0	12,5	+250	2,80
32300.W0403	Standard	Body Thermo, Ball S/S	3	2,00	3,6	4,0	0,60	0,55	1,7	3,5	-30/+50	0,09
32300.W0404	Standard	Body Thermo, Ball S/S	4	3,00	4,6	5,0	1,00	0,80	3,0	6,5	-30/+50	0,20
32300.W0405	Standard	Body Thermo, Ball S/S	5	4,00	5,6	6,0	1,00	1,00	6,0	9,4	-30/+50	0,40
32300.W0406	Standard	Body Thermo, Ball S/S	6	5,00	6,5	7,0	1,00	1,60	6,2	12,6	-30/+50	0,70
32300.W0408	Standard	Body Thermo, Ball S/S	8	6,50	8,5	9,0	1,00	1,90	10,0	20,4	-30/+50	1,50
32300.W0410	Standard	Body Thermo, Ball S/S	10	8,00	11,0	13,5	1,50	2,40	11,9	22,3	-30/+50	3,20
32300.W0412	Standard	Body Thermo, Ball S/S	12	10,00	13,0	16,0	1,50	3,30	14,0	25,0	-30/+50	5,80
32300.W0604	Standard	Body & Ball Thermoplast	4	3,00	4,6	5,0	1,00	0,80	3,0	6,5	-30/+50	0,10

Spring Plunger & Detent Pins

Spring Plungers

smooth model, with collar and ball- stainless steel



SPRING PLUNGER & DETENT PINS

Order No.	Spring load	Finish	d ₁ -0 +0.1	d ₂	d ₃	l ₁	l ₂ ≈	s ₁	Spring load	Spring load	Temperature °C max.	Weight g
									F ₁ N ≈	F ₂ N ≈		
32300.W0605	Standard	Body & Ball Thermoplast	5	4,00	5,6	6,0	1,00	1,00	6,0	9,4	-30/+50	0,20
32300.W0606	Standard	Body & Ball Thermoplast	6	5,00	6,5	7,0	1,00	1,60	6,2	12,6	-30/+50	0,30
32300.W0608	Standard	Body & Ball Thermoplast	8	6,50	8,5	9,0	1,00	1,90	10,0	20,4	-30/+50	0,60
32300.W0610	Standard	Body & Ball Thermoplast	10	8,00	11,0	13,5	1,50	2,40	11,9	22,3	-30/+50	1,50
32300.W0612	Standard	Body & Ball Thermoplast	12	10,00	13,0	16,0	1,50	3,30	14,0	25,0	-30/+50	2,50
32300.W2004	Heavy	Body & Ball Stainless	4	3,00	4,6	5,0	0,90	1,00	5,0	10,4	+250	0,30
32300.W2005	Heavy	Body & Ball Stainless	5	4,00	5,6	6,0	0,90	1,40	6,0	12,0	+250	0,60
32300.W2006	Heavy	Body & Ball Stainless	6	5,00	6,5	7,0	1,00	1,80	7,3	19,0	+250	1,00
32300.W2008	Heavy	Body & Ball Stainless	8	6,50	8,5	9,0	1,10	2,40	11,0	25,0	+250	2,10
32300.W2010	Heavy	Body & Ball Stainless	10	8,50	11,0	13,0	1,50	3,30	17,0	37,0	+250	4,40
32300.W2012	Heavy	Body & Ball Stainless	12	10,00	13,0	16,0	2,30	4,00	30,0	54,0	+250	7,30





Expander Fit Spring Plunger

smooth body - thermoplastic

Spring Plunger & Detent Pins

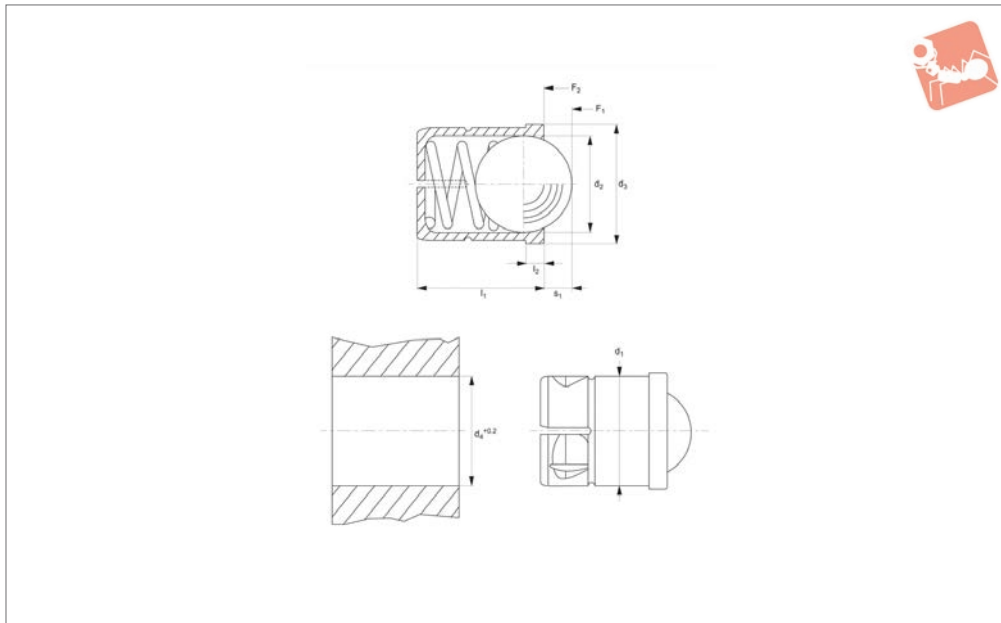

32302

SPRING PLUNGER & DETENT PINS

Material

Body: thermoplastic POM, black.
 Ball: ball bearing steel 1.3505 (100Cr6) hardened or thermoplastic POM, white.
 Spring: stainless steel.

Technical Notes

Unique body design flexes to expand and contract to fit in location bore tolerances

as wide as +0,2mm of d_4 . Especially suited to installation in plastic moulded components where hole and bore precision is not high.
 Guarantees a secure overhead installation. Simple push fit design, no special tooling necessary.
 For calculation of indexing resistance

please refer to spring plunger technical pages.

Tips

Spring load* - statistical average value.
 Temperature range -30°C to +50°C

See Wixroyd.com for:
 32305 - Spring plungers - INCH

Order No.	Finish	d_1 +0.1	d_2	d_3	d_4 +0.2	l_1 ±0.2	l_2 ≈	s_1	Spring load F_1 N ≈	Spring load F_2 N ≈	Temperature °C max.	Weight g
32302.W0704	Body Thermo & Ball Stainless	4	3,0	4,6	4	5,0	1,0	0,8	3,0	6,5	-30/+50	0,12
32302.W0705	Body Thermo & Ball Stainless	5	4,0	5,6	5	6,0	1,0	1,0	6,0	9,4	-30/+50	0,34
32302.W0706	Body Thermo & Ball Stainless	6	5,0	6,5	6	7,0	1,0	1,6	6,2	12,6	-30/+50	0,63
32302.W0708	Body Thermo & Ball Stainless	8	6,5	8,5	8	9,0	1,0	1,9	10,0	20,4	-30/+50	1,40
32302.W0710	Body Thermo & Ball Stainless	10	8,0	11,0	10	13,5	1,5	2,4	11,9	22,3	-30/+50	2,90
32302.W0804	Body & Ball Thermo	4	3,0	4,6	4	5,0	1,0	0,8	3,0	6,5	-30/+50	0,06
32302.W0805	Body & Ball Thermo	5	4,0	5,6	5	6,0	1,0	1,0	6,0	9,4	-30/+50	0,17
32302.W0806	Body & Ball Thermo	6	5,0	6,5	6	7,0	1,0	1,6	6,2	12,6	-30/+50	0,23
32302.W0808	Body & Ball Thermo	8	6,5	8,5	8	9,0	1,0	1,9	10,0	20,4	-30/+50	0,57
32302.W0810	Body & Ball Thermo	10	8,0	11,0	10	13,5	1,5	2,4	11,9	22,3	-30/+50	1,21



Struggle with inconsistent location bore tolerances and wide material variation?

Looking to reduce machining costs?

Our smooth body expander fit spring plunger offers a simple and accommodating solution - with the capacity to accommodate location bore tolerances as wide as $+0.2\text{mm}$.



Unique Expander Fit Design

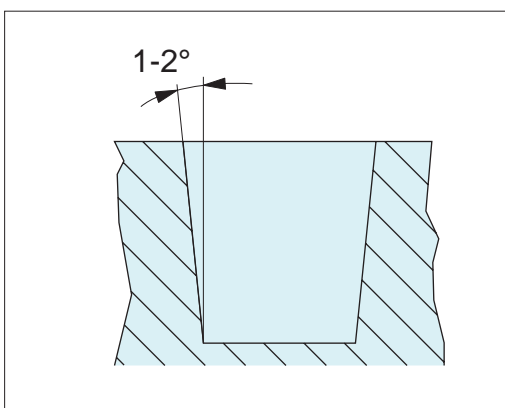

Typically, unmachined plastic injection moulded holes can vary widely in accuracy, with sidewall variation of ± 1 to 2° .

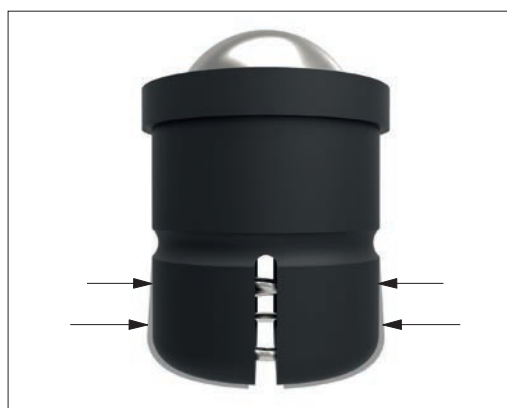

Unique body design flexes to expand and contract to fit in location bore tolerances as wide as $+0,2\text{mm}$.

Especially suited to installation in plastic moulded components where hole and bore precision is not high.

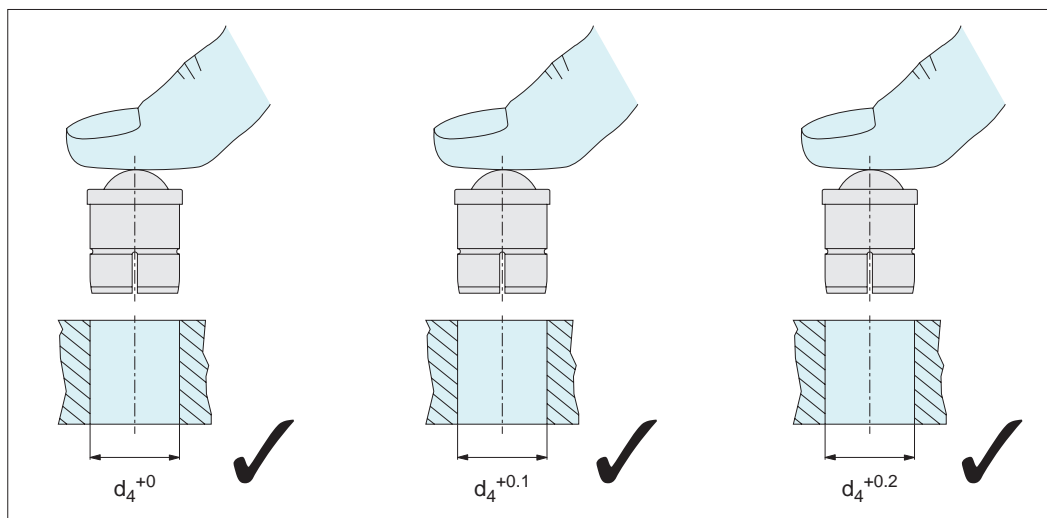

Expands/contracts to fit a range of hole tolerances from $+0$ to $+0,2$.

Unique Advantages

- Speed and flexibility in production and assembly.
- Removes need and cost of high tolerance machining and workpiece preparation.
- Easy push fit installation, no special tools or punches required.

Important Note

Important Note: It is not recommended to repeatedly install and uninstall expander fit spring plungers between locating bores of different tolerances, as such repeated action can lead to reduction of its capacity to expand into holes of wider tolerances (due to slight plastic fatigue).

As with all our smooth bodied spring plungers, best results are achieved when used as a single one-off installation.



Expander Fit Spring Plungers

smooth body, with collar and ball- **stainless steel**

Spring Plunger & Detent Pins

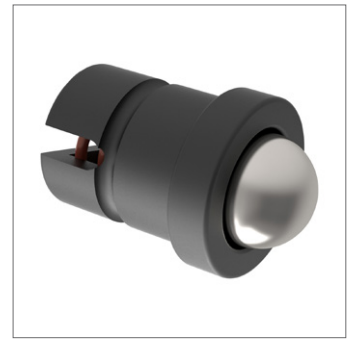
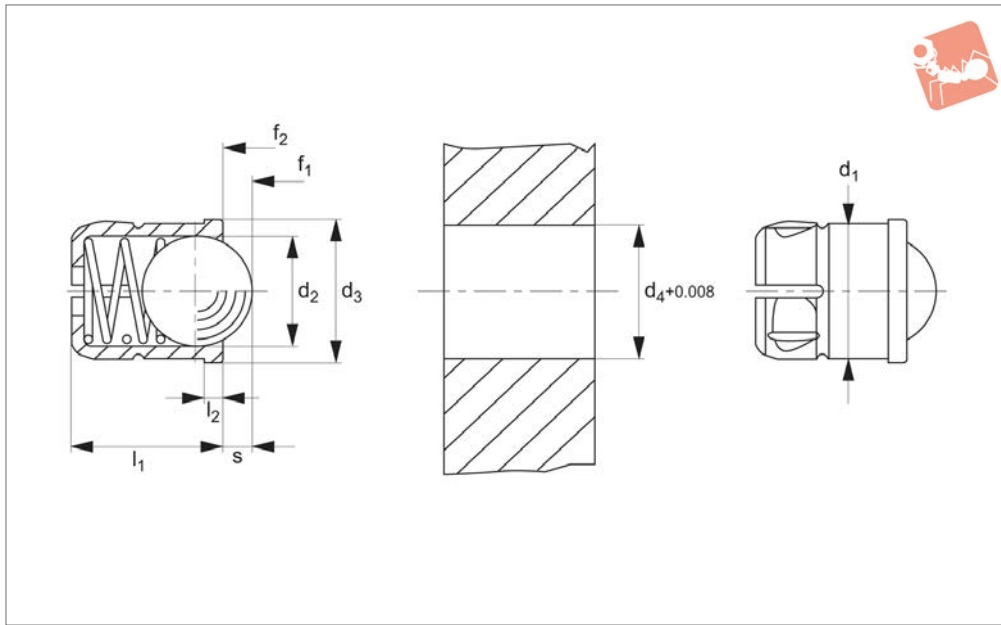

32305.web

SPRING PLUNGER & DETENT PINS

Material

Body: thermoplastic POM, black.
Ball: stainless steel hardened.
Spring: stainless steel.

Technical Notes

Used for locating, applying pressure,

detent or ejection.

Spring loads * = statistical average values.
Temperature range -5°C to +50°C.

Tips

Typical location hole tolerance is 0,008 inch due to flexible body.

Special types available on request.

Order No.	d ₁ +0.004	d ₂	d ₃ inch	d ₄ +0.008	l ₁ ±0.01	l ₂	Stroke s inch	Spring load f ₁ lb	Spring load f ₂ lb	Weight oz
32305.W0050	3/16	0.157	0.220	3/16	0.236	0.039	0.039	1.3	2.1	0.01
32305.W0060	1/4	0.197	0.276	1/4	0.276	0.039	0.059	1.4	2.8	0.02
32305.W0080	5/16	0.256	0.335	5/16	0.354	0.039	0.075	1.9	4.5	0.05
32305.W0090	3/8	0.315	0.433	3/8	0.531	0.059	0.091	2.7	5.0	0.10
32305.W0120	1/2	0.394	0.551	1/2	0.630	0.059	0.126	3.1	5.6	0.18

Spring Plunger & Detent Pins

Spring Plunger - Pin End - Smooth

stainless steel - with collar



SPRING PLUNGER & DETENT PINS



32282

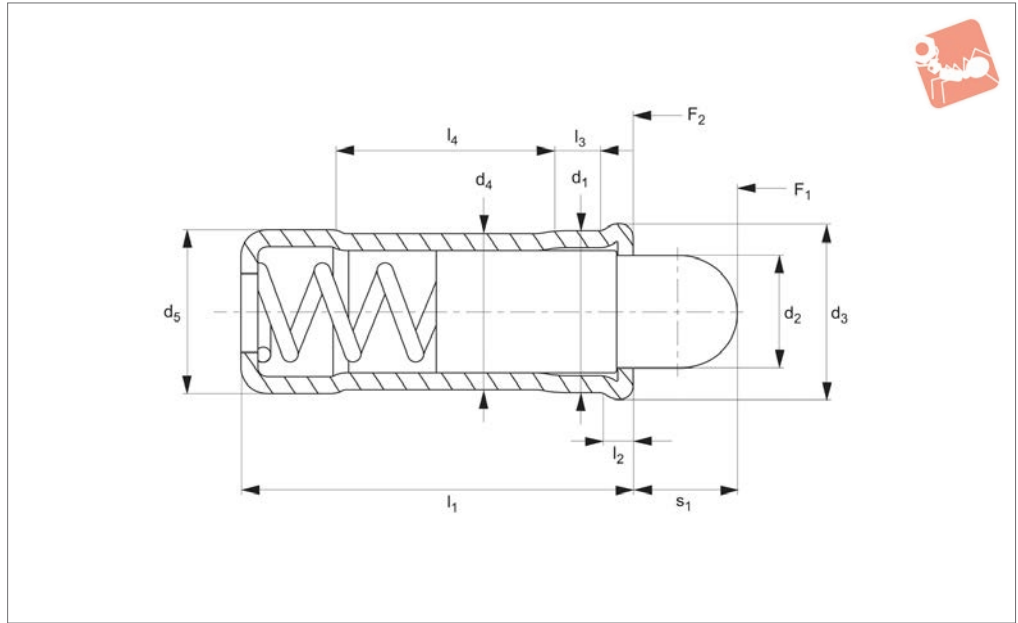

Material

Body: stainless steel 1.4303 (AISI 305).
 Pin: stainless steel 1.4305 (AISI 303), or thermoplastic POM white.
 Spring: stainless steel

lifting off.

Thermoplastic type temperature range - 30°C to +50°C.

Stainless type, temperature range max. 250°C.

Spring load * = statistical average value.

Tips

Special types available on request.

A tolerance of H7 is recommended for the locating hole of d₁.

Technical Notes

Used for locating, applying pressure or

Order No.	Pin type	d ₁ +0.1 +0.04	d ₂	d ₃	d ₄	d ₅ ±0.04	l ₁	l ₂ ≈	l ₃ ≈	l ₄ ≈	s ₁	Spring load F ₁ N ≈	Spring load F ₂ N ≈	Temperature °C max.	Weight g
32282.W0104	Stainless	4	2,8	4,6	3,85	4	10,7	0,9	1,8	5,6	2,7	3,0	8,2	+250	0,7
32282.W0105	Stainless	5	3,8	5,6	4,85	5	12,0	0,9	2,1	6,0	4,0	3,3	9,0	+250	1,2
32282.W0106	Stainless	6	4,8	6,5	5,85	6	15,0	1,0	2,3	8,2	5,5	6,1	12,0	+250	2,2
32282.W0108	Stainless	8	6,2	8,5	7,55	8	18,0	1,1	2,9	9,5	6,5	9,0	20,1	+250	4,2
32282.W0110	Stainless	10	8,1	11,0	9,55	10	26,0	1,5	4,2	14,3	8,0	16,2	29,0	+250	9,0
32282.W0124	Plastic	4	2,8	4,6	3,85	4	10,7	0,9	1,8	5,6	2,7	3,0	8,2	-30/+50	0,5
32282.W0125	Plastic	5	3,8	5,6	4,85	5	12,0	0,9	2,1	6,0	4,0	3,3	9,0	-30/+50	0,8
32282.W0126	Plastic	6	4,8	6,5	5,85	6	15,0	1,0	2,3	8,2	5,5	6,1	12,0	-30/+50	1,3
32282.W0128	Plastic	8	6,2	8,5	7,55	8	18,0	1,1	2,9	9,5	6,5	9,0	20,1	-30/+50	2,5
32282.W0130	Plastic	10	8,1	11,0	9,55	10	26,0	1,5	4,2	15,0	8,0	16,2	29,0	-30/+50	5,0



Spring Plunger - Ball End - Smooth

stainless steel - with collar

Spring Plunger & Detent Pins

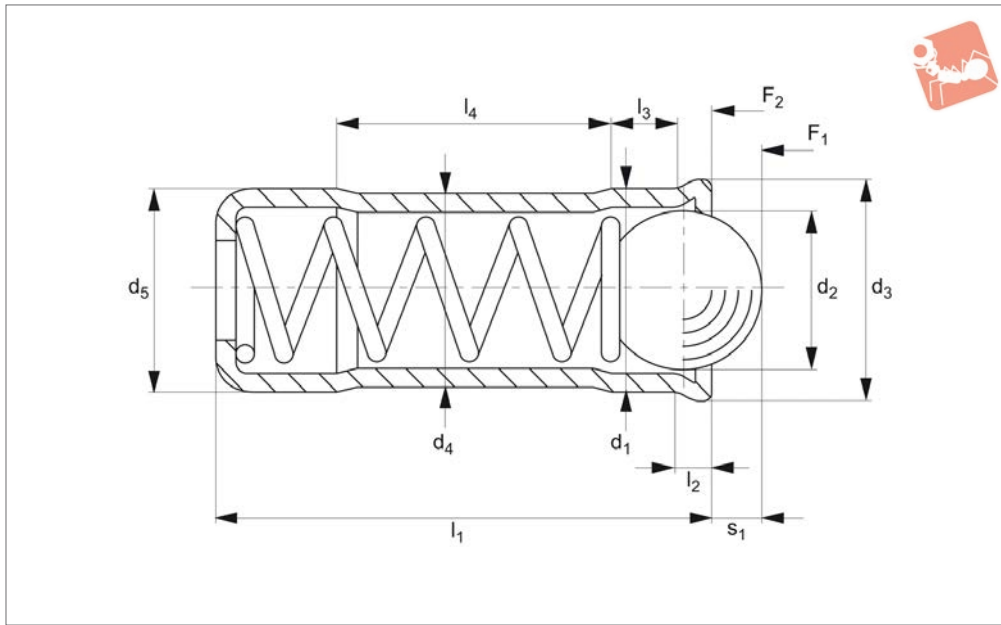

32284

SPRING PLUNGER & DETENT PINS

Material

Body: stainless steel 1.4303 (AISI 303).
Pin: stainless steel 1.4303 (AISI 303),
Spring: stainless steel.

lifting off.

Temperature range max. 250°C.
Spring load * = statistical average value.

locating hole of d_1 .

Technical Notes

Used for locating, applying pressure or

Tips

Special types available on request.
A tolerance of H7 is recommended for the

Order No.	d_1 +0.10 +0.04	d_2	d_3	d_4	d_5 ±0.04	l_1	l_2 ≈	l_3 ≈	l_4 ≈	Spring load F_1 N ≈	Spring load F_2 N ≈	Stroke s_1	Weight g
32284.W1104	4	3.0	4.6	3.85	4	10.7	0.9	1.8	5.6	12.9	19.0	0.9	0.6
32284.W1105	5	4.0	5.6	4.85	5	12.0	0.9	2.1	6.0	19.3	29.2	1.3	1.0
32284.W1106	6	5.0	6.5	5.85	6	15.0	1.0	2.3	8.2	28.0	47.5	1.7	2.0
32284.W1108	8	6.5	8.5	7.55	8	18.0	1.1	2.9	9.5	40.0	67.3	2.3	4.0
32284.W1110	10	8.5	11.0	9.55	10	26.0	1.5	4.2	14.3	66.0	105.0	3.1	8.0



32280

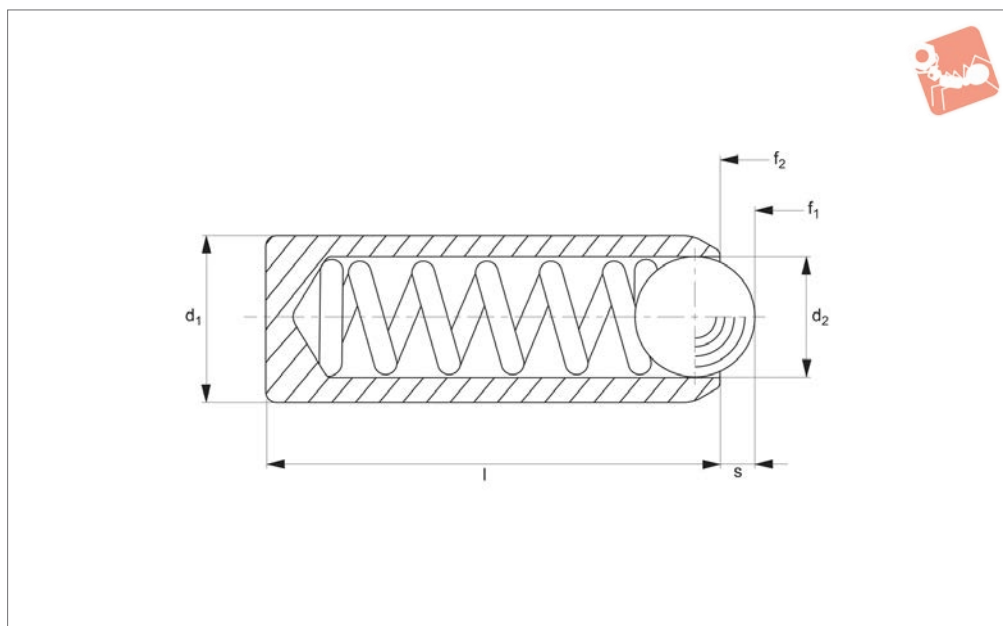

Material

Body: stainless steel 1.4305 (AISI 303).
 Ball: ball bearing steel 1.3505 (100Cr6) hardened.
 Spring: stainless steel

Technical Notes

Used for locating, applying pressure or

lifting off.

Temperature range up to +250°C. Spring load * = statistical average value.

Tips

These are press fit spring plungers, use tolerance of F8 for easy fit, or H9 when tight fit required. These tolerances vary

with material type, hence a trial hole is recommended.

Special types available on request.

Order No.	Pressure	d ₁ ±0.04	d ₂	l ₁	s ₁	Spring load F ₁ N ≈	Spring load F ₂ N ≈	Weight g
32280.W0306	Standard pressure	2.0	1.0	3.5	0.3	0.8	1.5	0.1
32280.W0308	Standard pressure	2.5	1.5	5.0	0.40	2.8	4.7	0.2
32280.W0310	Standard pressure	3.0	2.0	7.0	0.7	4.5	7.5	0.4
32280.W0312	Standard pressure	3.5	2.5	9.0	0.8	6.0	14.5	0.6
32280.W0315	Standard pressure	4.0	3.0	11.0	0.9	8.0	14.0	0.8
32280.W0317	Standard pressure	4.5	3.2	12.0	1.0	9.5	16.5	1.1
32280.W0320	Standard pressure	5.0	3.5	13.0	1.0	11.0	18.0	1.5
32280.W0322	Standard pressure	5.5	4.0	14.0	1.2	15.5	25.0	1.9
32280.W0325	Standard pressure	6.0	4.5	15.0	1.5	18.0	31.0	2.3
32280.W0327	Standard pressure	8.0	6.0	18.0	2.0	24.0	45.0	5.0
32280.W0330	Standard pressure	10.0	8.0	20.0	2.5	26.0	49.0	8.3
32280.W0332	Standard pressure	12.0	10.0	22.0	3.5	41.0	86.0	12
32280.W0356	High pressure	2.0	1.0	3.5	0.3	1.3	2.2	0.1
32280.W0358	High pressure	2.5	1.5	5.0	2.5	4.7	7.1	0.2
32280.W0360	High pressure	3.0	2.0	7.0	0.7	7.8	11.6	0.3
32280.W0362	High pressure	3.5	2.5	9.0	0.8	12.0	18.0	0.5
32280.W0365	High pressure	4.0	3.0	11.0	0.9	15.0	22.0	0.7
32280.W0367	High pressure	4.5	3.2	12.0	1.0	18.7	25.1	1.0
32280.W0370	High pressure	5.0	3.5	13.0	1.0	19.3	26.6	1.4
32280.W0372	High pressure	5.5	4.0	14.0	1.2	25.1	39.2	1.8
32280.W0375	High pressure	6.0	4.5	15.0	1.5	36.0	60.5	2.3
32280.W0377	High pressure	8.0	6.0	18.0	2.0	57.0	103.5	5.2
32280.W0380	High pressure	10.0	8.0	20.0	2.5	61.0	110.0	8.5
32280.W0382	High pressure	12.0	10.0	22.0	3.5	68.0	143.0	13

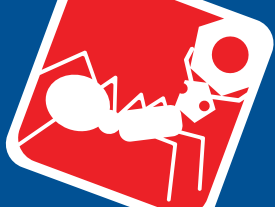

Spring Plungers

smooth model, without collar - stainless steel



Spring Plunger & Detent Pins

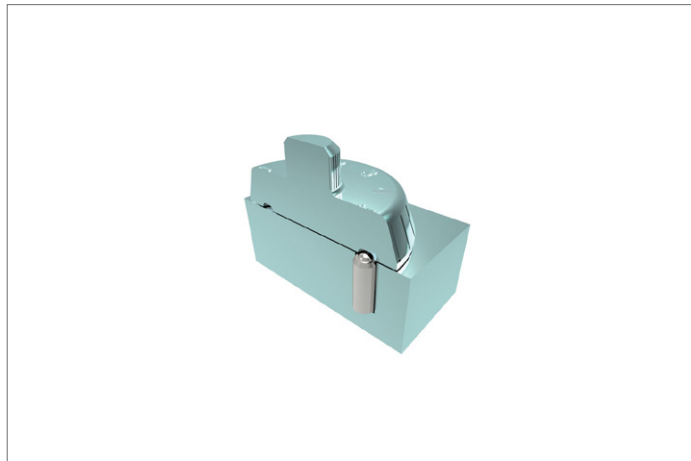

SPRING PLUNGER & DETENT PINS



32350

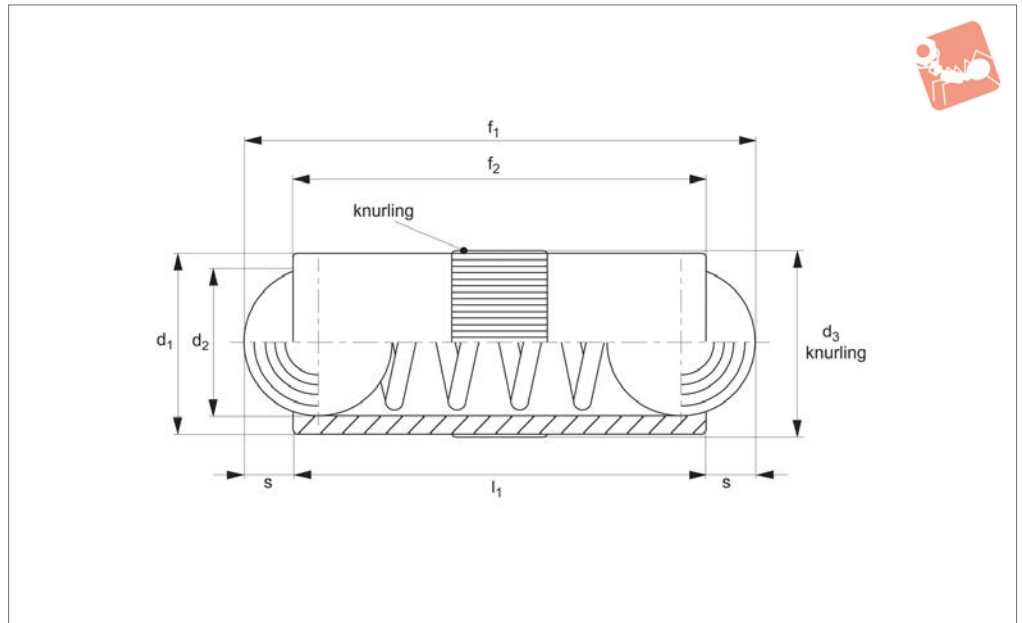

Material

Body: brass.
Ball: stainless steel, hardened.
Spring: stainless steel.

Technical Notes

Double ended spring plungers are used for axial locations and securing of bolts, as

well as a means of electrical contact (see diagram). Spring loads * = statistical average value.

For calculation of indexing resistance please refer to spring plunger technical pages.

Temperature resistance up to 250°C

Tips

Suggested hole tolerance for these spring plungers is H8.
Special types available on request.

Order No.	d_1 tol. h10	d_2	d_3 +0.05	l_1	s	Spring load F_1 N ≈	Spring load F_2 N ≈	Weight g
32350.W0025	2.5	2.0	2.52	5.3	0.65	1.3	2.5	0.22
32350.W0030	3.0	2.5	3.02	7.3	0.80	2.0	4.5	0.34
32350.W0040	4.0	3.0	4.03	9.0	0.90	2.5	7.5	0.65
32350.W0050	5.0	4.0	5.03	10.8	1.20	3.5	8.0	1.27
32350.W0060	6.0	5.0	6.03	12.6	1.60	3.5	10.5	1.99
32350.W0070	7.0	6.0	7.03	14.0	2.00	4.0	12.0	3.00
32350.W0080	8.0	6.5	8.03	18.0	2.10	6.0	15.0	5.10

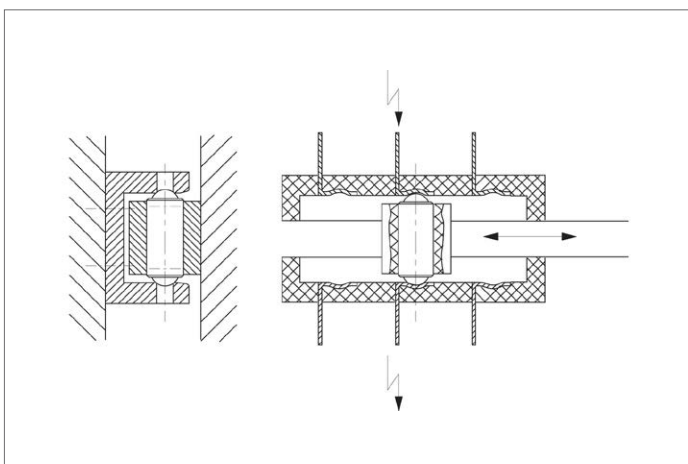



Spring Plungers

smooth model, long

Spring Plunger & Detent Pins

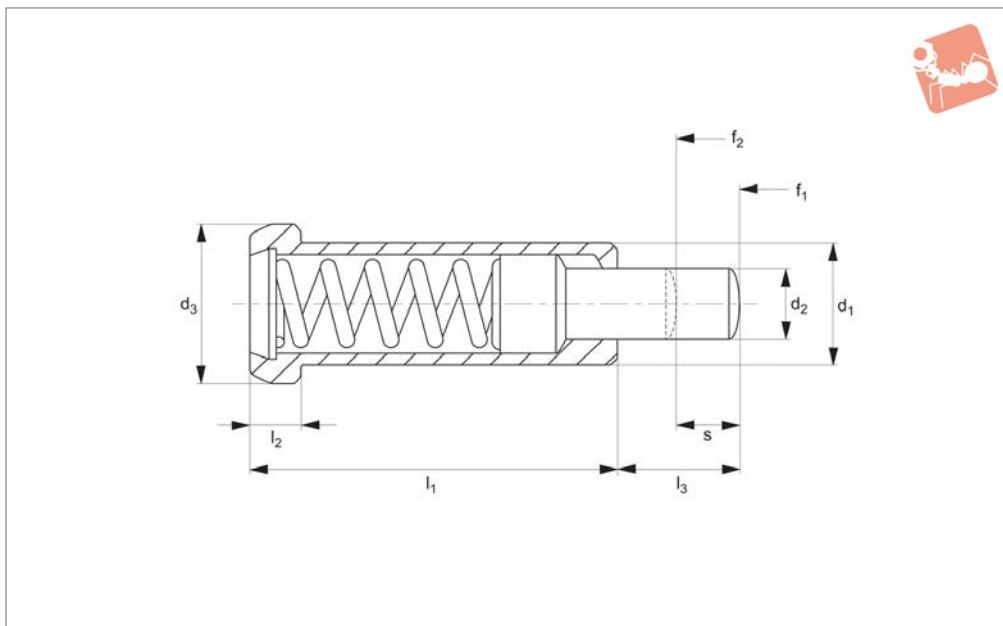

32400

SPRING PLUNGER & DETENT PINS

Material

Body: free cutting steel, blackened.
Pin: case hardened steel, blackened.
Spring: stainless steel.

Technical Notes

Used as pulling off pins and spring stops in

tool making. No part of the spring plunger can come out of the retaining bore. Recommended installation hole tolerance H7. Temperature range up to 250°C. Spring load * = statistical average values.

Tips

Do not push pin beyond spring range ,s', as this will damage spring and result in reduction of spring load. Special types available on request.

Order No.	d ₁ 0 -0.05	d ₂	d ₃	l ₁	l ₂	l ₃	Spring load F ₁ N ≈	Spring load F ₂ N ≈	s spring range	Weight g
32400.W0010	10	5.9	13	30	4.0	10	42	110	5.5	16.0
32400.W0006	6	2.7	8	20	3.2	6	10	22	3.5	4.2
32400.W0008	8	3.9	10	24	3.2	8	30	88	4.5	7.7
32400.W0012	12	7.9	16	36	5.0	12	50	130	6.5	27.0

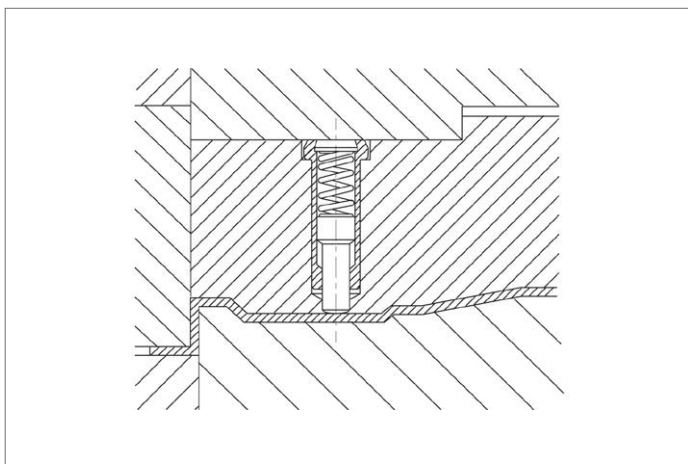



Wixroyd Spring Plungers - A Range of Endless Possibilities

Made of high quality steel and stainless steel, Wixroyd's Spring Plunger range is proven to be reliable for millions of repetitions in securing, positioning, positive locking, indexing and quick release. Their application is limited only by the imagination!

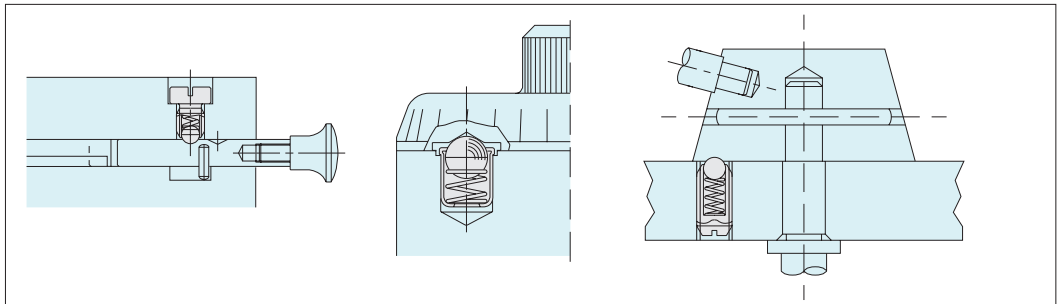

SPRING PLUNGER & DETENT PINS

Commercial Lighting

Three push-fit spring plungers no. 32000 have been added to the design of this recessed commercial light fitting. The push-fit design of the plunger makes for easy assembly during production. Their use greatly simplifies the mounting and servicing of the units, reducing handling costs and saving valuable operator time.

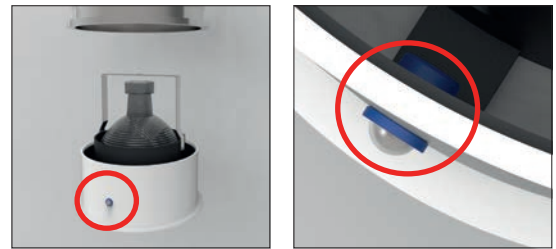

Medical Applications

Used in conjunction with a simple hinge, Wixroyd spring plunger 32300 provides an easy and secure means to positively position and secure the back panel of a blood gas analysis machine. With both brass and stainless steel varieties, our spring plungers have a wide range of application in the medical, pharmaceutical, food and drink processing industries.

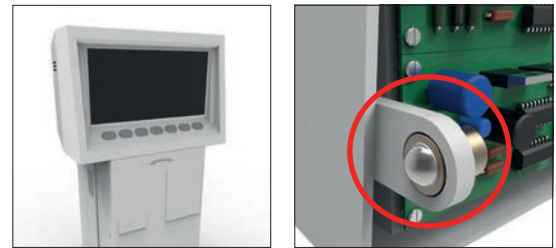

Applications

Uses

- For location, applying pressure and "lifting off".
- Securing and positioning.
- Positive locking and indexing.
- Quick release.

Industry Sectors

- Machine and fixture design.
- Measuring equipment.
- Electronic components.
- Lighting equipment.
- Medical, optics and orthopaedics.

Wixroyd Spring Plungers - Uses and Mounting Options

Ball Type

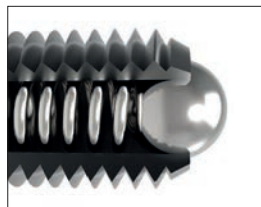

- 31400
- 31420
- 31500
- 32000
- 32100
- 32102
- 32280
- 32300
- 32302
- 32350

Mounting Options

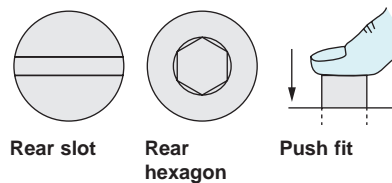

Pin Head Type

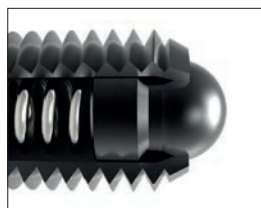

- 31000
- 31600
- 32150
- 32200
- 32220
- 32282
- 32400
- 32420

Mounting Options

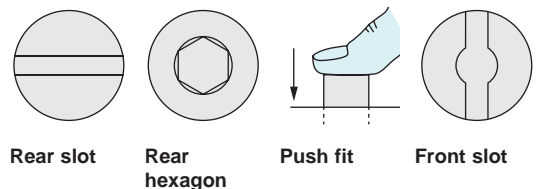



Quality products every time

- Every spring plunger that is produced on the Wixroyd assembly line is individually tested. That is how we guarantee the quality of our products.
- A Wixroyd spring plunger is tested against four key criteria during manufacture.

100% Testing

Accuracy of 'S' Stroke/ Spring Range



Accuracy of f_1 and f_2 Spring Forces



Accuracy of Ball Diameter

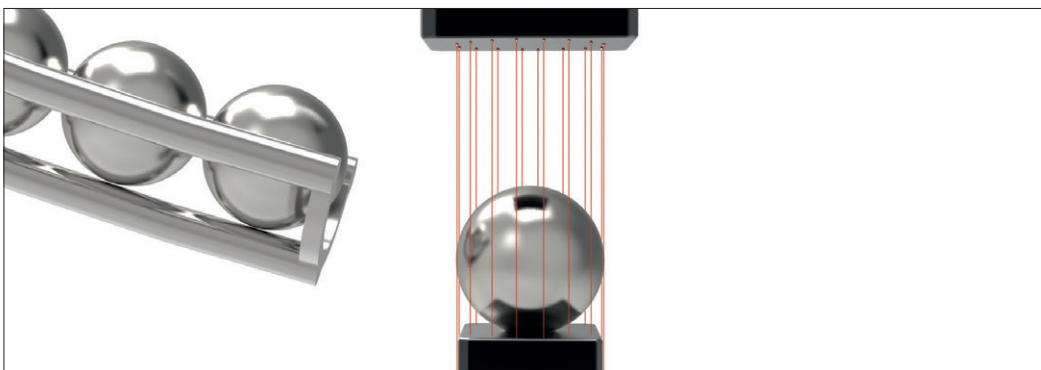

Accuracy of Thread

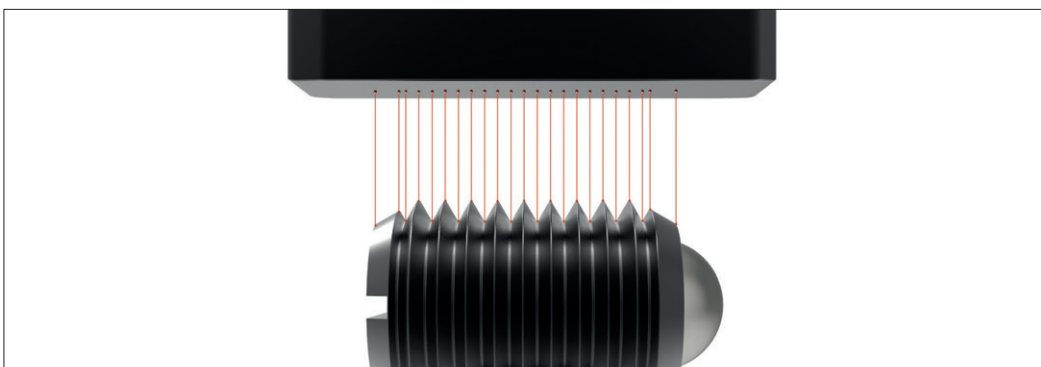



Thread Details

All Wixroyd metric spring plungers have a coarse thread.

Thread (D) Pitch	ISO metric coarse threads (mm)															
	3	3,5	4	4,5	5	6	7	8	10	12	14	16	18	20	22	24
	0,5	0,6	0,7	0,75	0,8	1,0	1,0	1,25	1,5	1,75	2,00	2,0	2,5	2,5	2,5	3,0

Spring Loads

- s Stroke, or movement of plunger's ball or pin.
- f₁ The force required in Newtons (N) to overcome the static strength of the spring and achieve initial movement of the plunger's ball or pin.
- f₂ The force required in Newtons (N) to fully compress the spring until the ball or pin is fully depressed against the plunger's body.

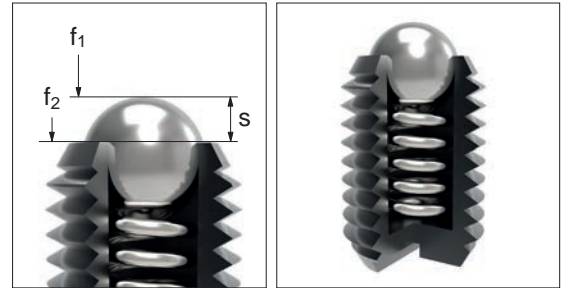

Typical Spring Repetitions

Although dependent upon a number of application specific factors, we are able to give the following guide relating to the maximum number of spring repetitions or cycles of our spring plungers.

- 100% or full stroke "s" used: approx. 300,000 cycles.
- 65% of stroke "s" used: approx 10,000,000 cycles.

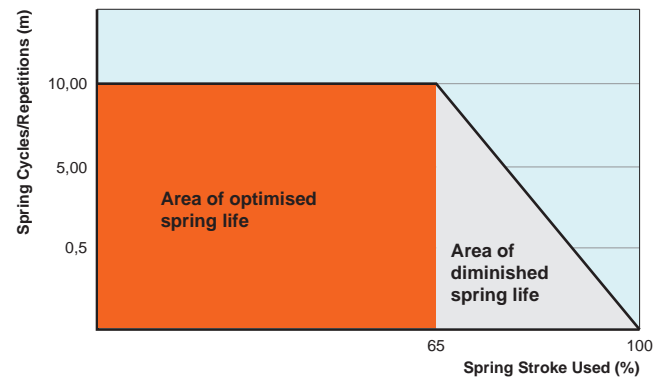

Calculating Indexing Resistance

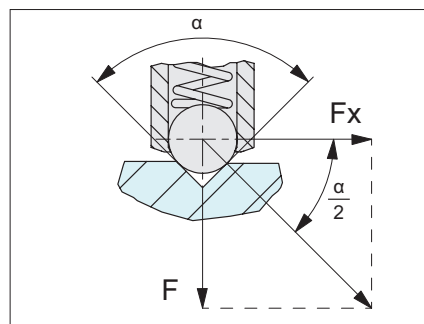

Important Note: This is only an approximation formula. For more accurate calculation the roughness of the counterpart surface as well as any variation in the plungers spring force (due to age or high repetitions) should be considered.

We are able to provide the following formula as an approximation of the pull or push force (N) required to 'release' a ball plunger from its indexing counterpart.

$$F_x = \frac{F}{\tan \frac{\alpha}{2}}$$

F_x = pull or push force (N)
 F = plungers spring force (see relevant product table)
 α = angle of the indexing counter part face

For example:

For Spring plunger 31500.W0010;
 $F = 24\text{N}$ (see product table)

If $\alpha = 90^\circ$

$$F_x = \frac{24}{\tan \frac{90}{2}} = 24\text{N}$$

If $\alpha = 60^\circ$

$$F_x = \frac{24}{\tan \frac{60}{2}} = 41,5\text{N}$$

If $\alpha = 120^\circ$

$$F_x = \frac{24}{\tan \frac{120}{2}} = 13,8\text{N}$$

Electrical Conductivity

We are often asked the electrical conductivity of our spring plungers, unfortunately we are unable to provide any reliable information related to this as there are many factors in an application. We recommend you study the specific material properties of the spring plunger's component parts to make your own calculations, alternatively if in doubt make a test application.

Specials to Your Own Design

Manufacturing exactly to your specific requirements is also our strength. If you need a variation in spring pressure, plunger body or pin design we can assist with a special design item for volumes as low as 1,000 units.

For further information, or to request a quotation, please call our sales office on 0333 207 4497.



Spring Plungers with ball & slot - stainless steel

Spring Plunger & Detent Pins

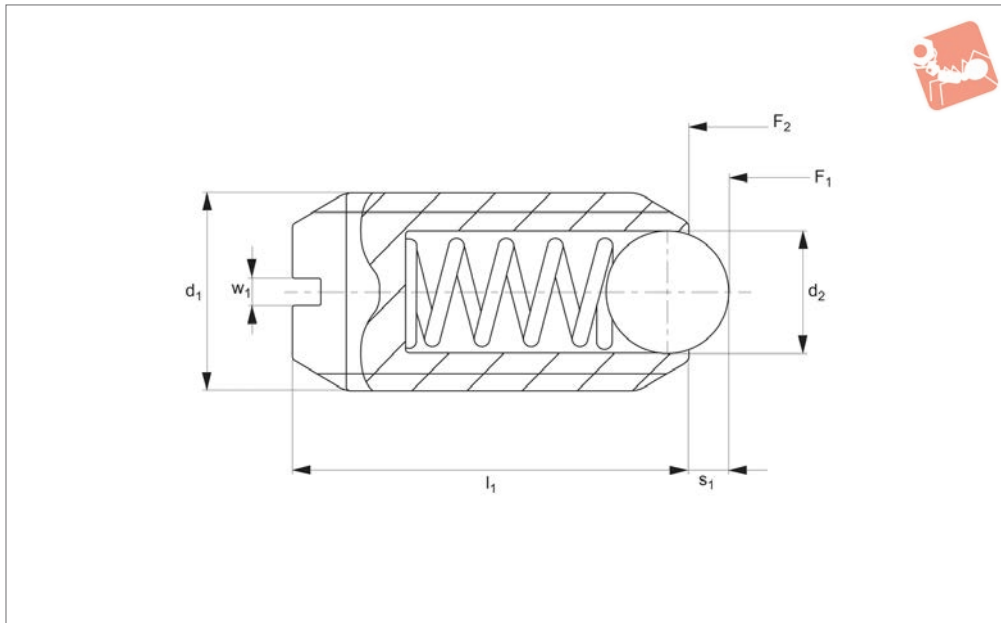

32100

SPRING PLUNGER & DETENT PINS

Material

Free cutting steel type-

Body: free cutting steel, blackened.
Ball: ball bearing steel 1.3505 (100Cr6) hardened.
Spring: stainless steel.

Stainless steel type-

Body: stainless steel 1.4305 (AISI 303).
Ball: stainless steel 1.3505 (100Cr6), hardened.
Spring: stainless steel.

Technical Notes

These spring plungers may be used for

location, for applying pressure or lifting off.

Temperature range up to 250°C. Spring load * = statistical average value.

For calculation of indexing resistance please refer to spring plunger technical pages.

Tips

Spring load identifier:

Normal spring load - no marking.
Increased spring load - body marked with two lines.

Special types available on request.

Important Notes

All metric Wixroyd spring plungers have a coarse thread, see appendix five for thread details.

Order No.	Material	Spring load	d ₁	d ₂	l ₁	Spring load F ₁ N ≈	Spring load F ₂ N ≈	Stroke s ₁	A/F	Weight g
32100.W0003	Steel	Normal	M 3	1.5	7	3.0	4.5	0.4	0.40	0.2
32100.W0004	Steel	Normal	M 4	2.5	9	8.5	14.0	0.8	0.60	0.4
32100.W0005	Steel	Normal	M 5	3.0	12	8.0	14.0	0.9	0.80	1.0
32100.W0006	Steel	Normal	M 6	3.5	14	11.0	18.0	1.0	1.00	1.7
32100.W0008	Steel	Normal	M 8	4.5	16	18.0	31.0	1.5	1.20	3.5
32100.W0010	Steel	Normal	M10	6.0	19	24.0	45.0	2.0	1.50	6.6
32100.W0012	Steel	Normal	M12	8.0	22	26.0	49.0	2.5	2.00	11.0
32100.W0016	Steel	Normal	M16	10.0	24	41.0	86.0	3.5	2.00	23.0
32100.W0020	Steel	Normal	M20	12.0	30	56.0	111.0	4.5	2.50	45.0
32100.W0024	Steel	Normal	M24	15.0	34	81.0	151.0	5.5	3.00	72.0
32100.W0205	Steel	Increased	M 5	3.0	12	15.0	22.0	0.9	0.80	1.0
32100.W0206	Steel	Increased	M 6	3.5	14	19.0	28.0	1.0	1.00	1.7
32100.W0208	Steel	Increased	M 8	4.5	16	36.0	62.0	1.5	1.20	3.6
32100.W0210	Steel	Increased	M10	6.0	19	57.0	104.0	2.0	1.50	6.6
32100.W0212	Steel	Increased	M12	8.0	22	61.0	110.0	2.5	2.00	11.0
32100.W0216	Steel	Increased	M16	10.0	24	68.0	142.0	3.5	2.00	23.0
32100.W0220	Steel	Increased	M20	12.0	30	84.0	166.0	4.5	2.50	43.0
32100.W0224	Steel	Increased	M24	15.0	34	127.0	237.0	5.5	3.00	72.0
32100.W0402	Stainless	Normal	M 2	1.0	4	0.8	1.5	0.3	0.25	0.1
32100.W0403	Stainless	Normal	M 3	1.5	7	3.0	4.5	0.4	0.40	0.2
32100.W0404	Stainless	Normal	M 4	2.5	9	8.5	14.0	0.8	0.60	0.4
32100.W0405	Stainless	Normal	M 5	3.0	12	8.0	14.0	0.9	0.80	1.0



Order No.	Material	Spring load	d ₁	d ₂	l ₁	Spring load F ₁ N ≈	Spring load F ₂ N ≈	Stroke s ₁	A/F	Weight g
32100.W0406	Stainless	Normal	M 6	3.5	14	11.0	18.0	1.0	1.00	1.7
32100.W0408	Stainless	Normal	M 8	4.5	16	18.0	31.0	1.5	1.20	3.5
32100.W0410	Stainless	Normal	M10	6.0	19	24.0	45.0	2.0	1.50	6.6
32100.W0412	Stainless	Normal	M12	8.0	22	26.0	49.0	2.5	2.00	11.0
32100.W0416	Stainless	Normal	M16	10.0	24	41.0	86.0	3.5	2.00	23.0
32100.W0420	Stainless	Normal	M20	12.0	30	56.0	111.0	4.5	2.50	45.0
32100.W0424	Stainless	Normal	M24	15.0	34	81.0	151.0	5.5	3.00	72.0
32100.W0605	Stainless	Increased	M 5	3.0	12	15.0	22.0	0.9	0.80	1.0
32100.W0606	Stainless	Increased	M 6	3.5	14	19.0	28.0	1.0	1.00	1.7
32100.W0608	Stainless	Increased	M 8	4.5	16	36.0	62.0	1.5	1.20	3.6
32100.W0610	Stainless	Increased	M10	6.0	19	57.0	104.0	2.0	1.50	6.6
32100.W0612	Stainless	Increased	M12	8.0	22	61.0	110.0	2.5	2.00	11.0
32100.W0616	Stainless	Increased	M16	10.0	24	68.0	142.0	3.5	2.00	23.0
32100.W0620	Stainless	Increased	M20	12.0	30	84.0	166.0	4.5	2.50	43.0
32100.W0624	Stainless	Increased	M24	15.0	34	127.0	237.0	5.5	3.00	72.0

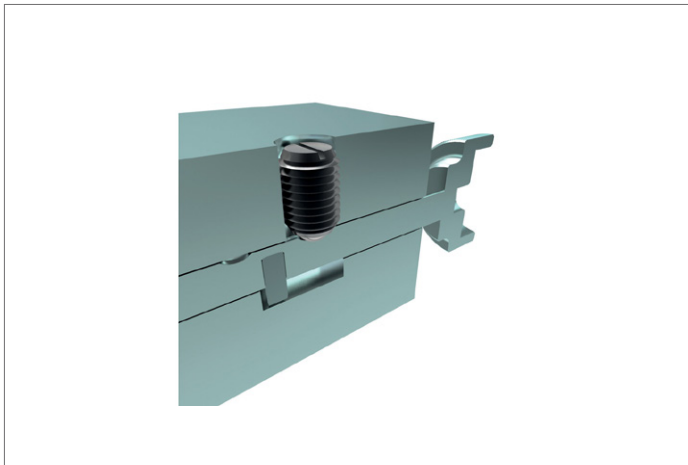



Spring Plungers with ball & slot - headed

Spring Plunger & Detent Pins

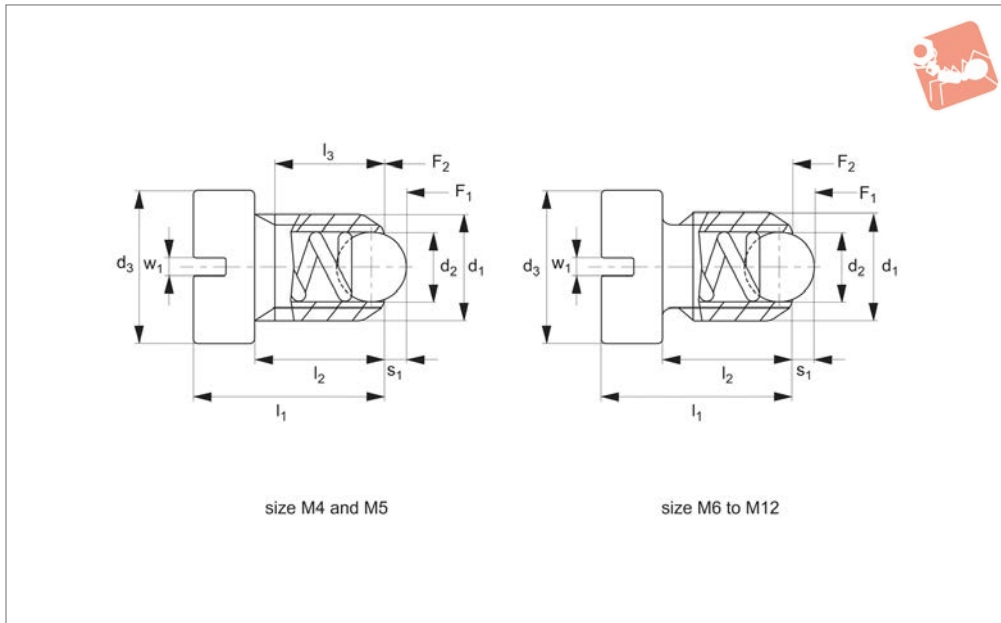

31400

SPRING PLUNGER & DETENT PINS

Material

Free cutting steel type-

Body: free cutting steel, blackened.
Ball: ball bearing steel 1.3505 (100Cr6), hardened.
Spring: stainless steel.

Stainless steel type-

Body: stainless steel 1.4305 (AISI 303).
Ball: stainless steel 1.3505 (100Cr6),

hardened.

Spring: stainless steel.

For calculation of indexing resistance please refer to appendix - Technical Data.

Technical Notes

Max. temperature 250°C. Spring loads = statistical average.
For M4 and M5 threads dimension l_3 is max.

screw in depth, i.e. there is no undercut. For calculation of indexing resistance please refer to spring plunger technical pages.

Important Notes

All metric Wixroyd spring plungers have a coarse thread, see appendix five for thread details.

Order No.	Material	d_1	d_2	d_3	l_1	l_2	l_3	Spring load F_1 N ≈	Spring load F_2 N ≈	Stroke s_1	w_1	Weight g
31400.W0940	Stainless	M 4	2.5	6	9.5	6.5	5.0	8	14	0.8	0.6	1.2
31400.W0941	Stainless	M 5	3.0	8	12.5	8.5	6.7	8	14	0.9	0.8	2.4
31400.W0942	Stainless	M 6	3.5	10	14.0	9.0	-	11	18	1.0	1.0	3.9
31400.W0943	Stainless	M 8	4.5	13	16.5	11.0	-	18	31	1.5	1.2	7.9
31400.W0944	Stainless	M10	6.0	16	20.0	14.0	-	24	45	2.0	1.5	14.0
31400.W0945	Stainless	M12	8.0	18	22.0	15.0	-	26	49	2.5	2.0	20.0
31400.W0930	Steel	M 4	2.5	6	9.5	6.5	5.0	8	14	0.8	0.6	1.2
31400.W0931	Steel	M 5	3.0	8	12.5	8.5	6.7	8	14	0.9	0.8	2.4
31400.W0932	Steel	M 6	3.5	10	14.0	9.0	-	11	18	1.0	1.0	3.9
31400.W0933	Steel	M 8	4.5	13	16.5	11.0	-	18	31	1.5	1.2	7.9
31400.W0934	Steel	M10	6.0	16	20.0	14.0	-	24	45	2.0	1.5	14.0
31400.W0935	Steel	M12	8.0	18	22.0	15.0	-	26	49	2.5	2.0	20.0

Spring Plunger & Detent Pins



Spring Plungers with ball & slot - headed



SPRING PLUNGER & DETENT PINS

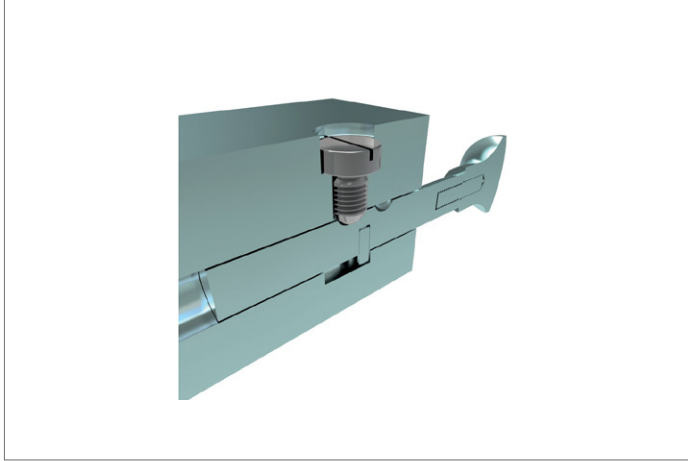

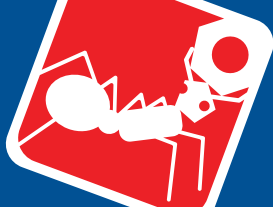

Spring Plungers with ball end & hex. socket - headed

Spring Plunger & Detent Pins

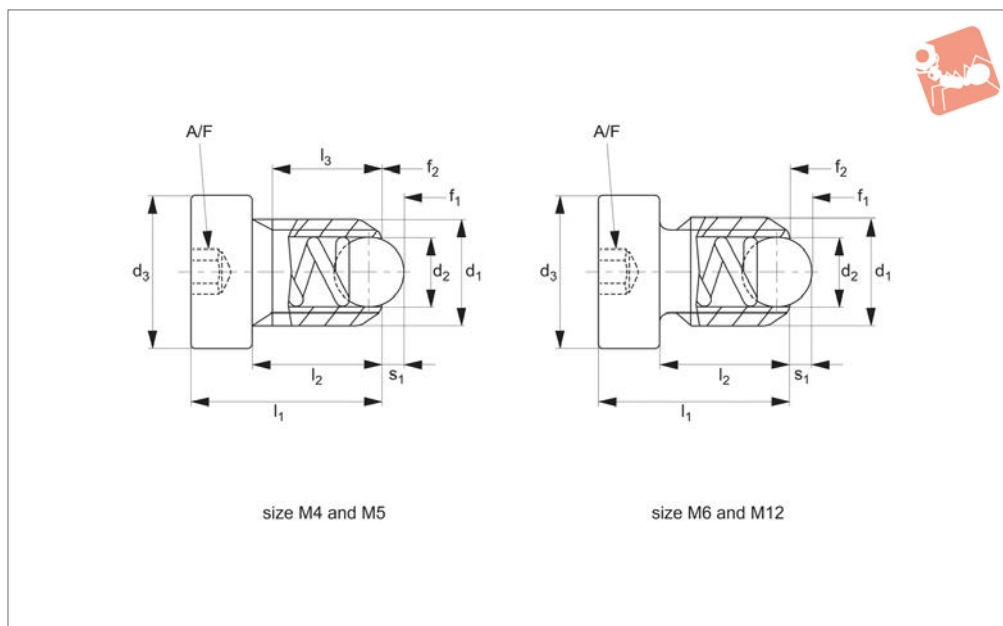

31420

SPRING PLUNGER & DETENT PINS

Material

Free cutting steel type-

Body: free cutting steel, blackened.

Ball: ball bearing steel 1.3505 (100Cr6) hardened.

Spring: stainless steel.

Stainless steel type-

Body: stainless steel 1.4305 (AISI 303).

Ball: stainless steel 1.3505 (100Cr6), hardened.

Spring: stainless steel.

Technical Notes

Max. temperature 250°C. Spring loads = statistical average.

For M4 and M5 threads dimension l_3 is max.

screw in depth, i.e. there is no undercut.

For calculation of indexing resistance please refer to spring plunger technical pages.

Tips

Used for locating, applying pressure or lifting off. Special types available on request.

Important Notes

All metric Wixroyd spring plungers have a coarse thread, see appendix five for thread details.

Order No.	Material	d_1	d_2	d_3	l_1	l_2	l_3	Spring load F_1 N ≈	Spring load F_2 N ≈	Stroke s_1	A/F	Weight g
31420.W0940	Stainless	M 4	2.5	6	12	9.0	7.5	8	14	0.8	2.0	1.1
31420.W0941	Stainless	M 5	3.0	8	14	10.0	8.2	8	14	0.9	2.5	2.3
31420.W0942	Stainless	M 6	3.5	10	15	10.0	-	11	18	1.0	3.0	3.9
31420.W0943	Stainless	M 8	4.5	13	18	12.5	-	18	31	1.5	4.0	7.8
31420.W0944	Stainless	M10	6.0	16	23	17.0	-	24	45	2.0	5.0	14.0
31420.W0945	Stainless	M12	8.0	18	26	19.0	-	26	49	2.5	6.0	21.0
31420.W0930	Steel	M 4	2.5	6	12	9.0	7.5	8	14	0.8	2.0	1.1
31420.W0931	Steel	M 5	3.0	8	14	10.0	8.2	8	14	0.9	2.5	2.3
31420.W0932	Steel	M 6	3.5	10	15	10.0	-	11	18	1.0	3.0	3.9
31420.W0933	Steel	M 8	4.5	13	18	12.5	-	18	31	1.5	4.0	7.8
31420.W0934	Steel	M10	6.0	16	23	17.0	-	24	45	2.0	5.0	14.0
31420.W0935	Steel	M12	8.0	18	26	19.0	-	26	49	2.5	6.0	21.0



31500

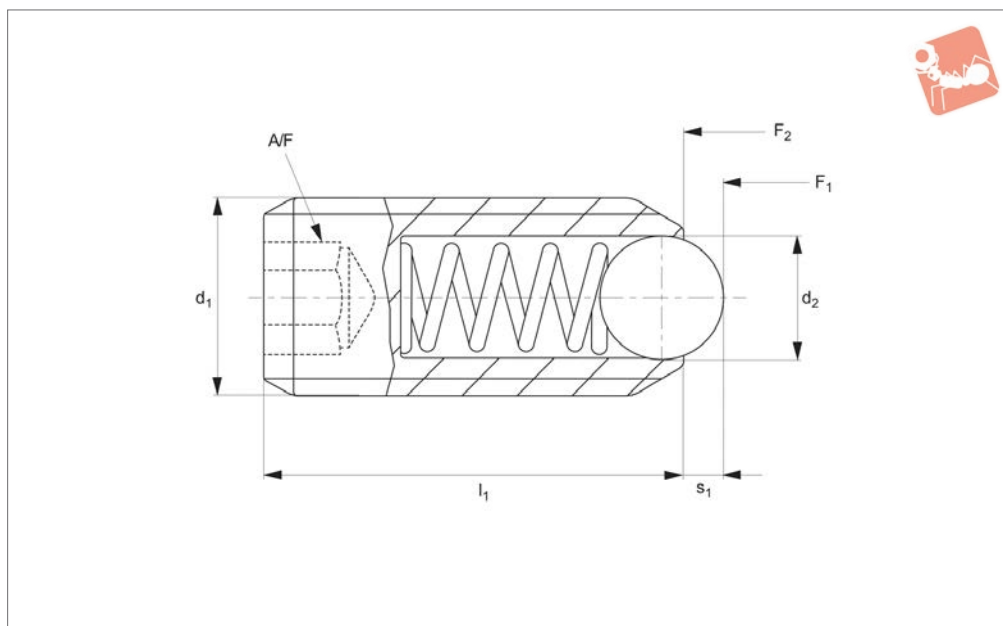

Material

Free cutting steel type-

Body: free cutting steel, blackened. Ball: ball bearing steel 1.3505 (100Cr6) hardened. Spring: stainless steel.

Stainless steel type-

Body: stainless steel 1.4305 (AISI 303). Ball: stainless steel 1.3505 (100Cr6), hardened. Spring: stainless steel.

Technical Notes

These spring plungers may be used for

location, for applying pressure or lifting off.

Temperature range max. 250° C.

Spring load * = statistical average value.

For calculation of indexing resistance please refer to spring plunger technical pages.

Tips

Spring load identifier:

Normal spring load - no marking.

Increased spring load - body marked with two lines.

Special types available on request.

Important Notes

All metric Wixroyd spring plungers have a coarse thread, see appendix five for thread details.

Order No.	Material	Spring load	d ₁	d ₂	l ₁	Spring load F ₁ N ≈	Spring load F ₂ N ≈	Stroke s ₁	A/F	Weight g
31500.W0204	Stainless	Normal	M 4	2.5	12	8.5	14.0	0.8	2.0	0.7
31500.W0203	Stainless	Normal	M 3	1.5	8	3.0	4.5	0.4	1.5	0.3
31500.W0205	Stainless	Normal	M 5	3.0	14	8.0	14.0	0.9	2.5	1.2
31500.W0206	Stainless	Normal	M 6	3.5	15	11.0	18.0	1.0	3.0	1.8
31500.W0208	Stainless	Normal	M 8	4.5	18	18.0	31.0	1.5	4.0	3.9
31500.W0210	Stainless	Normal	M10	6.0	23	24.0	45.0	2.0	5.0	8.1
31500.W0212	Stainless	Normal	M12	8.0	26	26.0	49.0	2.5	6.0	13.0
31500.W0216	Stainless	Normal	M16	10.0	33	41.0	86.0	3.5	8.0	32.0
31500.W0220	Stainless	Normal	M20	12.0	43	56.0	111.0	4.5	10.0	66.0
31500.W0224	Stainless	Normal	M24	15.0	48	81.0	151.0	5.5	12.0	106.0
31500.W0245	Stainless	Increased	M 5	3.0	14	15.0	22.0	0.9	2.5	1.2
31500.W0246	Stainless	Increased	M 6	3.5	15	19.0	28.0	1.0	3.0	1.9
31500.W0248	Stainless	Increased	M 8	4.5	18	36.0	62.0	1.5	4.0	4.2
31500.W0250	Stainless	Increased	M10	6.0	23	57.0	104.0	2.0	5.0	8.2
31500.W0252	Stainless	Increased	M12	8.0	26	61.0	110.0	2.5	6.0	13.0
31500.W0256	Stainless	Increased	M16	10.0	33	68.0	142.0	3.5	8.0	33.0
31500.W0260	Stainless	Increased	M20	12.0	43	84.0	166.0	4.5	10.0	66.0
31500.W0264	Stainless	Increased	M24	15.0	48	127.0	237.0	5.5	12.0	107.0
31500.W0004	Steel	Normal	M 4	2.5	12	8.5	14.0	0.8	2.0	0.7
31500.W0003	Steel	Normal	M 3	1.5	8	3.0	4.5	0.4	1.5	0.3
31500.W0005	Steel	Normal	M 5	3.0	14	8.0	14.0	0.9	2.5	1.2
31500.W0006	Steel	Normal	M 6	3.5	15	11.0	18.0	1.0	3.0	1.8
31500.W0008	Steel	Normal	M 8	4.5	18	18.0	31.0	1.5	4.0	3.9



Spring Plungers with ball end & hex. socket



Spring Plunger & Detent Pins

Order No.	Material	Spring load	d ₁	d ₂	l ₁	Spring load F ₁ N ≈	Spring load F ₂ N ≈	Stroke s ₁	A/F	Weight g
31500.W0010	Steel	Normal	M10	6.0	23	24.0	45.0	2.0	5.0	8.1
31500.W0012	Steel	Normal	M12	8.0	26	26.0	49.0	2.5	6.0	13.0
31500.W0016	Steel	Normal	M16	10.0	33	41.0	86.0	3.5	8.0	32.0
31500.W0020	Steel	Normal	M20	12.0	43	56.0	111.0	4.5	10.0	66.0
31500.W0024	Steel	Normal	M24	15.0	48	81.0	151.0	5.5	12.0	106.0
31500.W0045	Steel	Increased	M 5	3.0	14	15.0	22.0	0.9	2.5	1.2
31500.W0046	Steel	Increased	M 6	3.5	15	19.0	28.0	1.0	3.0	1.9
31500.W0048	Steel	Increased	M 8	4.5	18	36.0	62.0	1.5	4.0	4.2
31500.W0050	Steel	Increased	M10	6.0	23	57.0	104.0	2.0	5.0	8.2
31500.W0052	Steel	Increased	M12	8.0	26	61.0	110.0	2.5	6.0	13.0
31500.W0056	Steel	Increased	M16	10.0	33	68.0	142.0	3.5	8.0	33.0
31500.W0060	Steel	Increased	M20	12.0	43	84.0	166.0	4.5	10.0	66.0
31500.W0064	Steel	Increased	M24	15.0	48	127.0	237.0	5.5	12.0	107.0

SPRING PLUNGER & DETENT PINS



SPRING PLUNGER & DETENT PINS



31610

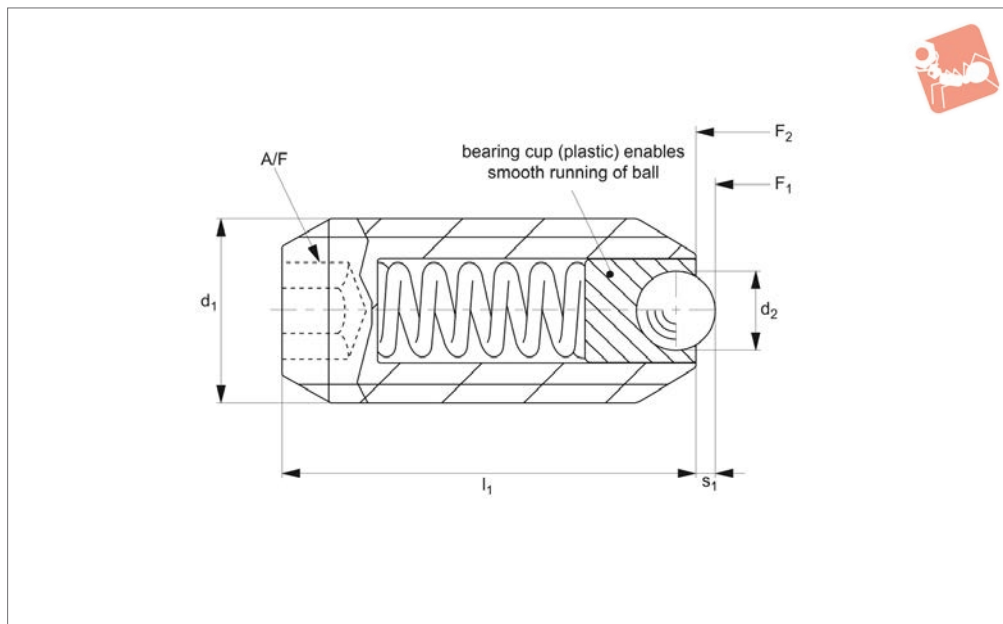

Material

Free cutting steel type-

Body: free cutting steel, blackened.

Ball: ball bearing steel 1.3505(100Crb), hardened.

Spring: stainless steel.

Bearing cup: plastic.

Body: stainless steel, 1.4305(AISI 303).

Ball: ball bearing steel 1.3505(100Crb), hardened.

Spring: stainless steel.

Bearing cup: plastic.

unique plastic „bearing cup“, angling the smooth running of the ball.

This offers a solution with less friction, for reduced surface damage to mounting parts.

In addition the plastic cup offers electrical insulation.

Stainless steel type-

Technical Notes

Plunger's ball bearing is mounted in a

Temperature range -30°C to +90°C.

Order No.	Material	Spring load	d ₁	d ₂	l ₁	s ₁	Spring load F ₁ N ≈	Spring load F ₂ N ≈	A/F	Weight g
31610.W0005	Steel	Normal	M 5	2.0	14	0.50	4.8	6.8	2.5	1.1
31610.W0006	Steel	Normal	M 6	2.5	15	0.70	6.3	10.0	3.0	2.1
31610.W0008	Steel	Normal	M 8	3.5	18	0.95	16.0	24.0	4.0	4.8
31610.W0010	Steel	Normal	M10	4.5	23	1.40	18.8	31.7	5.0	10.0
31610.W0012	Steel	Normal	M12	6.5	26	2.30	26.0	49.0	6.0	15.0
31610.W0016	Steel	Normal	M16	8.5	33	3.10	38.0	68.0	8.0	37.0
31610.W0045	Steel	Increased	M 5	2.0	14	0.50	10.0	14.0	2.5	1.2
31610.W0046	Steel	Increased	M 6	2.5	15	0.70	11.0	16.0	3.0	2.2
31610.W0048	Steel	Increased	M 8	3.5	18	0.95	23.0	40.0	4.0	5.0
31610.W0050	Steel	Increased	M10	4.5	23	1.40	54.3	54.3	5.0	10.0
31610.W0052	Steel	Increased	M12	6.5	26	2.30	39.5	77.3	6.0	15.0
31610.W0056	Steel	Increased	M16	8.5	33	3.10	50.0	88.7	8.0	37.0
31610.W0205	Stainless	Normal	M 5	2.0	14	0.50	4.8	6.8	2.5	1.1
31610.W0206	Stainless	Normal	M 6	2.5	15	0.70	6.3	10.0	3.0	2.1
31610.W0208	Stainless	Normal	M 8	3.5	18	0.95	16.0	24.0	4.0	4.8
31610.W0210	Stainless	Normal	M10	4.5	23	1.40	18.8	31.7	5.0	10.0
31610.W0212	Stainless	Normal	M12	6.5	26	2.30	26.0	49.0	6.0	15.0
31610.W0216	Stainless	Normal	M16	8.5	33	3.10	38.0	68.0	8.0	37.0
31610.W0245	Stainless	Increased	M 5	2.0	14	0.50	10.0	14.0	2.5	1.2
31610.W0246	Stainless	Increased	M 6	2.5	15	0.70	11.0	16.0	3.0	2.2
31610.W0248	Stainless	Increased	M 8	3.5	18	0.95	23.0	40.0	4.0	5.0
31610.W0250	Stainless	Increased	M10	4.5	23	1.40	28.0	54.3	5.0	10.0
31610.W0252	Stainless	Increased	M12	6.5	26	2.30	39.5	77.3	6.0	15.0
31610.W0256	Stainless	Increased	M16	8.5	33	3.10	50.0	88.7	8.0	37.0



Spring Plungers plastic version

Spring Plunger & Detent Pins

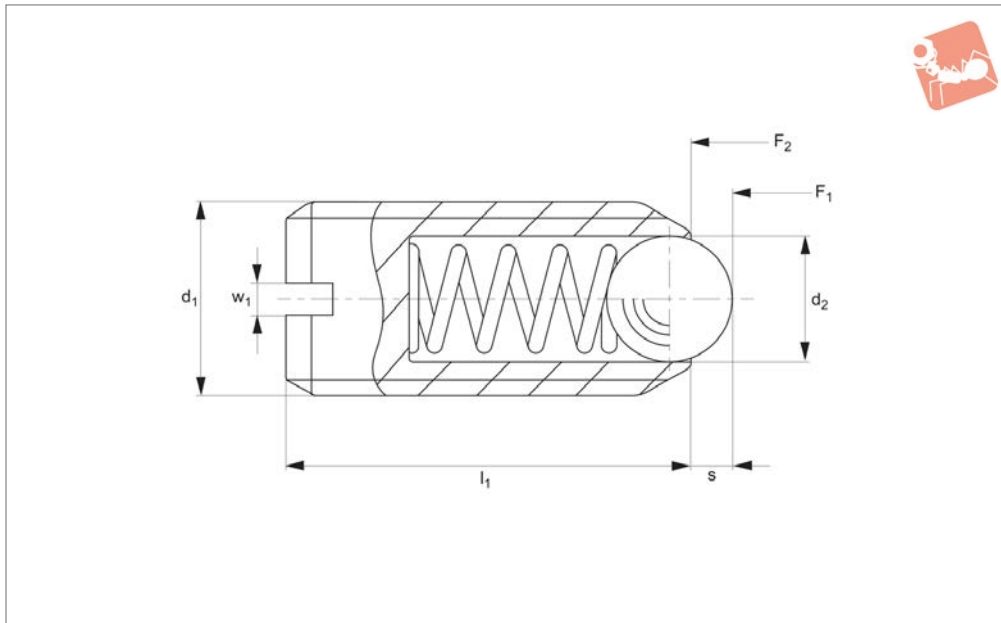

32000

SPRING PLUNGER & DETENT PINS

Material

Body: thermoplastic POM, blue.
Ball: hardened stainless steel 1.3541 or white thermoplastic POM.
Spring: stainless steel.

Temperature range -30°C to +50°C.
Spring loads * = statistical average value.
For calculation of indexing resistance please refer to spring plunger technical pages.

Special types available on request.

Technical Notes

Used for locating, applying pressure or lifting off.

Tips

May be used where electrical conductivity is not required.

Important Notes

All metric Wixroyd spring plungers have a coarse thread, see appendix five for thread details.

Order No.	Ball finish	d ₁	d ₂	l ₁	s	Spring load F ₁ N ≈	Spring load F ₂ N ≈	w ₁	Weight g
32000.W0006	Stainless	M 6	3.5	14	0.9	12	17	1.0	0.6
32000.W0008	Stainless	M 8	5.0	16	1.5	20	35	1.2	1.3
32000.W0010	Stainless	M10	6.0	19	1.9	25	45	1.5	2.6
32000.W0406	Thermo	M 6	3.5	14	0.9	12	17	1.0	0.5
32000.W0408	Thermo	M 8	5.0	16	1.5	20	35	1.2	1.0
32000.W0410	Thermo	M10	6.0	19	1.9	25	45	1.5	1.8



32102

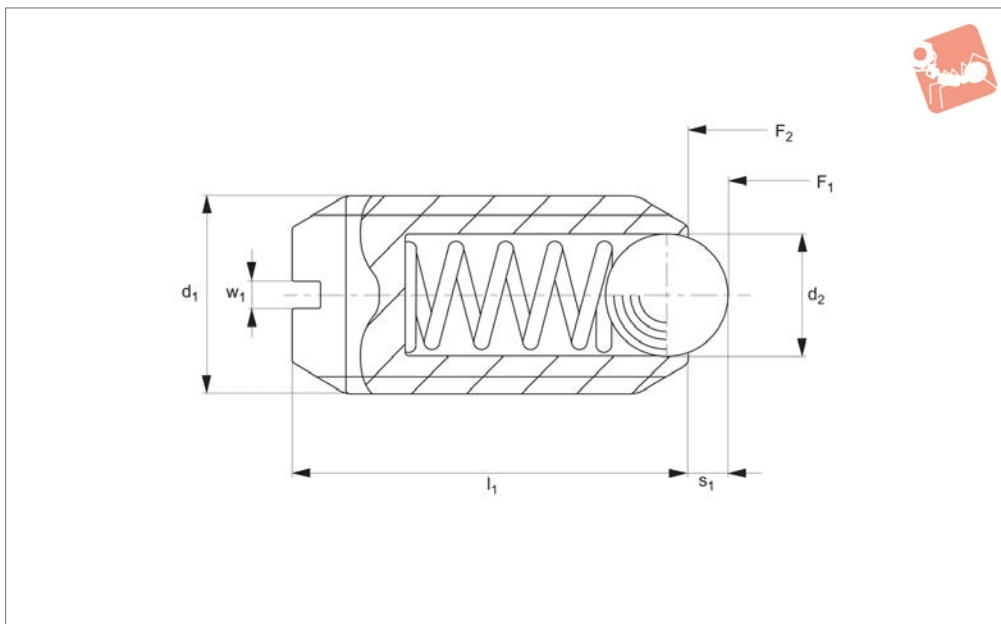

Material

Body: stainless steel A4, passivated.
 Ball: ceramic (silicone nitride), black.
 Spring: stainless steel A4, passivated

Technical Notes

To be used for locating or for applying pressure, as a detent or for ejection. The version from stainless steel A4 guarantees

the highest corrosion protection.
 Ceramic ball: abrasion resistant, antima-
 gnetic, electrically isolating.
 Temperature range up to max. 250°C.
 Spring load * = Statistical average value.
 For calculation of indexing resistance
 please refer to spring plunger technical
 pages.

Tips

Spring load identifier:
 Normal spring load - no marking.
 Increased spring load - body marked with
 two lines.
 Special types available on request.

Order No.	Spring load	d ₁	d ₂	l ₁	s ₁	Spring load F ₁ N ≈	Spring load F ₂ N ≈	w ₁	Weight g
32102.W1404	Normal	M 4	2.5	9	0.8	8.5	14	0.6	0.4
32102.W1405	Normal	M 5	3.0	12	0.9	8.0	14	0.8	0.9
32102.W1406	Normal	M 6	3.5	14	1.0	11.0	18	1.0	1.6
32102.W1408	Normal	M 8	4.5	16	1.5	18.0	31	1.2	3.5
32102.W1410	Normal	M10	6.0	19	2.0	24.0	45	1.5	6.2
32102.W1412	Normal	M12	8.0	22	2.5	26.0	49	2.0	9.8
32102.W1416	Normal	M16	10.0	24	3.5	41.0	86	2.0	19.8
32102.W1605	Increased	M 5	3.0	12	0.9	15.0	22	0.8	1.1
32102.W1606	Increased	M 6	3.5	14	1.0	19.0	28	1.0	1.8
32102.W1608	Increased	M 8	4.5	16	1.5	36.0	62	1.2	3.4
32102.W1610	Increased	M10	6.0	19	2.0	57.0	104	1.5	6.1
32102.W1612	Increased	M12	8.0	22	2.5	61.0	110	2.0	9.8
32102.W1616	Increased	M16	10.0	24	3.5	68.0	142	2.0	19.8

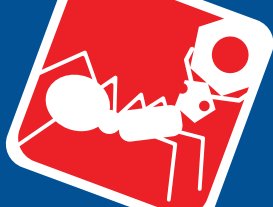

Spring Plungers

with round-ended pin & hex. socket



Spring Plunger & Detent Pins

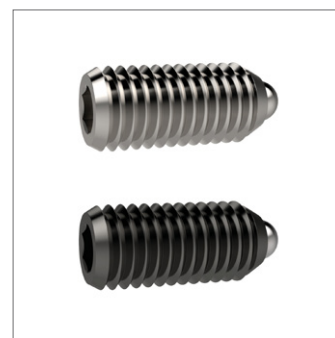
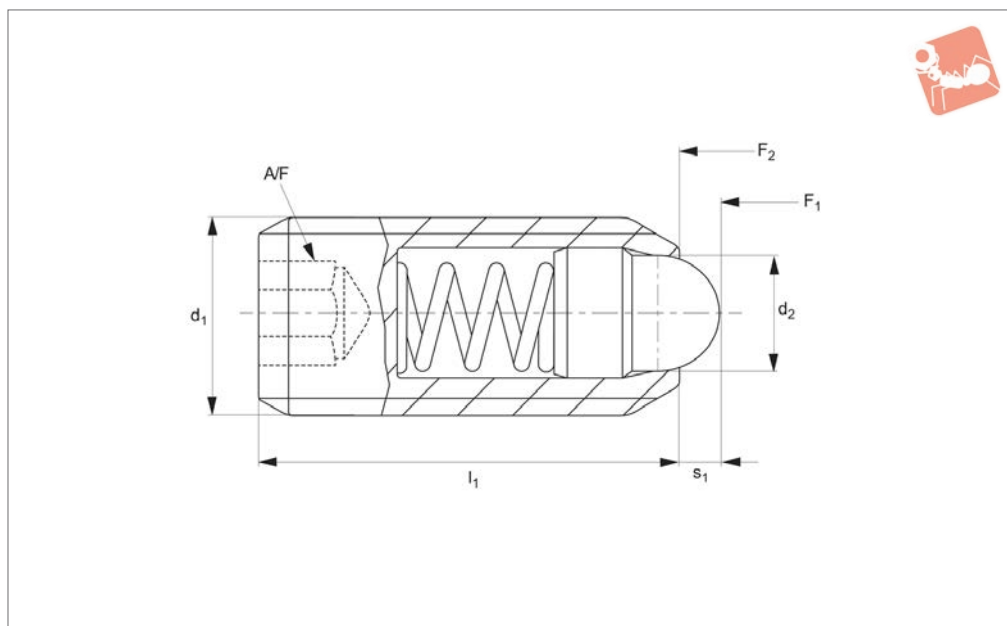

31600

SPRING PLUNGER & DETENT PINS

Material

Free cutting steel type-

Body: free cutting steel, blackened.

Pin: free cutting steel, hardened, blackened.

Spring: stainless steel.

Stainless steel type-

Body: stainless steel 1.4305 (AISI 303).

Pin: stainless steel 1.4305 (AISI 303).

Spring: stainless steel.

Technical Notes

These spring plungers may be used for locating, for applying pressure or lifting off.

Temperature range max. 250° C. Spring load * = statistical average value.

Tips

Spring load identifier:

Normal spring load - no marking.

Increased spring load - body marked with two lines.

Special types available on request.

Important Notes

All metric Wixroyd spring plungers have a coarse thread, see appendix five for thread details.

Order No.	Material	Spring load	d ₁	d ₂	l ₁	Spring load F ₁ N ≈	Spring load F ₂ N ≈	Stroke s ₁	A/F	Weight g
31600.W0104	Steel	Normal	M 4	1.8	12	4.5	12.5	1.5	2.0	0.6
31600.W0105	Steel	Normal	M 5	2.4	14	5.0	13.0	2.0	2.5	1.3
31600.W0106	Steel	Normal	M 6	2.7	15	6.0	17.0	2.0	3.0	1.9
31600.W0108	Steel	Normal	M 8	3.8	18	16.0	33.0	2.0	4.0	4.2
31600.W0110	Steel	Normal	M10	4.5	23	19.0	42.0	2.5	5.0	8.5
31600.W0112	Steel	Normal	M12	6.2	26	22.0	57.0	3.5	6.0	13.0
31600.W0116	Steel	Normal	M16	8.5	33	38.0	78.0	4.5	8.0	32.0
31600.W0120	Steel	Normal	M20	10.0	43	39.0	81.0	6.5	10.0	67.0
31600.W0124	Steel	Normal	M24	13.0	48	72.0	155.0	8.0	12.0	106.0
31600.W0146	Steel	Increased	M 6	2.7	15	11.0	25.0	2.0	3.0	2.0
31600.W0148	Steel	Increased	M 8	3.8	18	23.0	59.0	2.0	4.0	4.2
31600.W0150	Steel	Increased	M10	4.5	23	20.0	54.0	2.5	5.0	8.5
31600.W0152	Steel	Increased	M12	6.2	26	38.0	96.0	3.5	6.0	13.0
31600.W0156	Steel	Increased	M16	8.5	33	50.0	100.0	4.5	8.0	32.0
31600.W0160	Steel	Increased	M20	10.0	43	52.0	133.0	6.5	10.0	67.0
31600.W0164	Steel	Increased	M24	13.0	48	91.0	223.0	8.0	12.0	106.0
31600.W0304	Stainless	Normal	M 4	1.8	12	4.5	12.5	1.5	2.0	0.6
31600.W0305	Stainless	Normal	M 5	2.4	14	5.0	13.0	2.0	2.5	1.3
31600.W0306	Stainless	Normal	M 6	2.7	15	6.0	17.0	2.0	3.0	1.9
31600.W0308	Stainless	Normal	M 8	3.8	18	16.0	33.0	2.0	4.0	4.2
31600.W0310	Stainless	Normal	M10	4.5	23	19.0	42.0	2.5	5.0	8.5
31600.W0312	Stainless	Normal	M12	6.2	26	22.0	57.0	3.5	6.0	13.0
31600.W0316	Stainless	Normal	M16	8.5	33	38.0	78.0	4.5	8.0	32.0
31600.W0320	Stainless	Normal	M20	10.0	43	39.0	81.0	6.5	10.0	67.0
31600.W0324	Stainless	Normal	M24	13.0	48	72.0	155.0	8.0	12.0	106.0
31600.W0346	Stainless	Increased	M 6	2.7	15	11.0	25.0	2.0	3.0	2.0

Spring Plunger & Detent Pins



Spring Plungers with round-ended pin & hex. socket



Order No.	Material	Spring load	d ₁	d ₂	l ₁	Spring load F ₁ N ≈	Spring load F ₂ N ≈	Stroke s ₁	A/F	Weight g
31600.W0348	Stainless	Increased	M 8	3.8	18	23.0	59.0	2.0	4.0	4.2
31600.W0350	Stainless	Increased	M10	4.5	23	20.0	54.0	2.5	5.0	8.5
31600.W0352	Stainless	Increased	M12	6.2	26	38.0	96.0	3.5	6.0	13.0
31600.W0356	Stainless	Increased	M16	8.5	33	50.0	100.0	4.5	8.0	32.0
31600.W0360	Stainless	Increased	M20	10.0	43	52.0	133.0	6.5	10.0	67.0
31600.W0364	Stainless	Increased	M24	13.0	48	91.0	223.0	8.0	12.0	106.0

SPRING PLUNGER & DETENT PINS

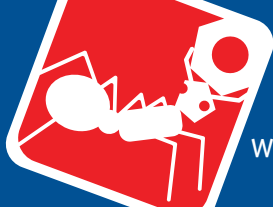

Spring Plungers

with round-ended pin & slot - stainless steel or steel

Spring Plunger & Detent Pins

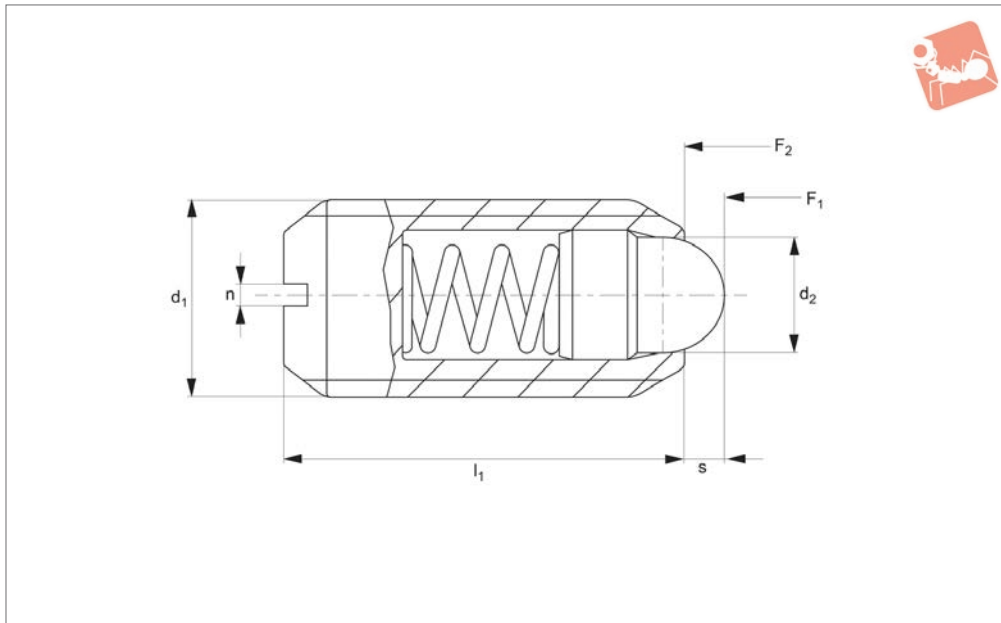

32150

SPRING PLUNGER & DETENT PINS

Material

Free cutting steel type-

Body: free cutting steel, blackened.

Pin: free cutting steel, hardened, blackened.

Spring: stainless steel.

Stainless steel type-

Body: stainless steel 1.4305 (AISI 303).

Pin: stainless steel, 1.4305 (AISI 303).

Spring: stainless steel.

Technical Notes

These spring plungers may be used for location, for applying pressure or lifting off.

Temperature range up to 250°C. Spring load * = statistical average value.

Tips

Spring load identifier:

Normal spring load - no marking.

Increased spring load - body marked with two lines.

Special types available on request.

Important Notes

All metric Wixroyd spring plungers have a coarse thread, see appendix five for thread details.

Order No.	Material	Spring load	d ₁	d ₂	l ₁	n ₁	s ₁	Spring load F ₁ N ≈	Spring load F ₂ N ≈	Weight g
32150.W0104	Steel	Normal	M 4	1.8	9	0.6	1.5	4.5	12.5	0.4
32150.W0105	Steel	Normal	M 5	2.4	12	0.8	2.0	5.0	13.0	1.1
32150.W0106	Steel	Normal	M 6	2.7	14	1.0	2.0	6.0	17.0	1.8
32150.W0108	Steel	Normal	M 8	3.8	16	1.2	2.0	16.0	33.0	3.7
32150.W0110	Steel	Normal	M10	4.5	19	1.5	2.5	19.0	42.0	7.1
32150.W0112	Steel	Normal	M12	6.2	22	2.0	3.5	22.0	57.0	11.0
32150.W0116	Steel	Normal	M16	8.5	24	2.0	4.5	38.0	78.0	23.0
32150.W0120	Steel	Normal	M20	10.0	30	2.5	6.5	39.0	81.0	46.0
32150.W0124	Steel	Normal	M24	13.0	34	3.0	8.0	72.0	155.0	73.0
32150.W0306	Steel	Increased	M 6	2.7	14	1.0	2.0	11.0	25.0	1.8
32150.W0308	Steel	Increased	M 8	3.8	16	1.2	2.0	23.0	59.0	3.8
32150.W0310	Steel	Increased	M10	4.5	19	1.5	2.5	20.0	54.0	7.0
32150.W0312	Steel	Increased	M12	6.2	22	2.0	3.5	38.0	96.0	11.0
32150.W0320	Steel	Increased	M20	10.0	30	2.5	6.5	52.0	133.0	46.0
32150.W0324	Steel	Increased	M24	13.0	34	3.0	8.0	91.0	223.0	74.0
32150.W0504	Stainless	Normal	M 4	1.8	9	0.6	1.5	4.5	12.5	0.4
32150.W0505	Stainless	Normal	M 5	2.4	12	0.8	2.0	5.0	13.0	1.1
32150.W0506	Stainless	Normal	M 6	2.7	14	1.0	2.0	6.0	17.0	1.8
32150.W0508	Stainless	Normal	M 8	3.8	16	1.2	2.0	16.0	33.0	3.7
32150.W0510	Stainless	Normal	M10	4.5	19	1.5	2.5	19.0	42.0	7.1
32150.W0512	Stainless	Normal	M12	6.2	22	2.0	3.5	22.0	57.0	11.0
32150.W0516	Stainless	Normal	M16	8.5	24	2.0	4.5	38.0	78.0	23.0
32150.W0520	Stainless	Normal	M20	10.0	30	2.5	6.5	39.0	81.0	46.0
32150.W0524	Stainless	Normal	M24	13.0	34	3.0	8.0	72.0	155.0	73.0
32150.W0706	Stainless	Increased	M 6	2.7	14	1.0	2.0	11.0	25.0	1.8
32150.W0708	Stainless	Increased	M 8	3.8	16	1.2	2.0	23.0	59.0	3.8

Spring Plunger & Detent Pins



Spring Plungers

with round-ended pin & slot - stainless steel or steel



Order No.	Material	Spring load	d_1	d_2	l_1	n_1	s_1	Spring load F_1 N \approx	Spring load F_2 N \approx	Weight g
32150.W0710	Stainless	Increased	M10	4.5	19	1.5	2.5	20.0	54.0	7.0
32150.W0712	Stainless	Increased	M12	6.2	22	2.0	3.5	38.0	96.0	11.0
32150.W0720	Stainless	Increased	M20	10.0	30	2.5	6.5	52.0	133.0	46.0
32150.W0724	Stainless	Increased	M24	13.0	34	3.0	8.0	91.0	223.0	74.0

SPRING PLUNGER & DETENT PINS



Spring Plungers

with pin end & hex. socket - stainless steel



Spring Plunger & Detent Pins

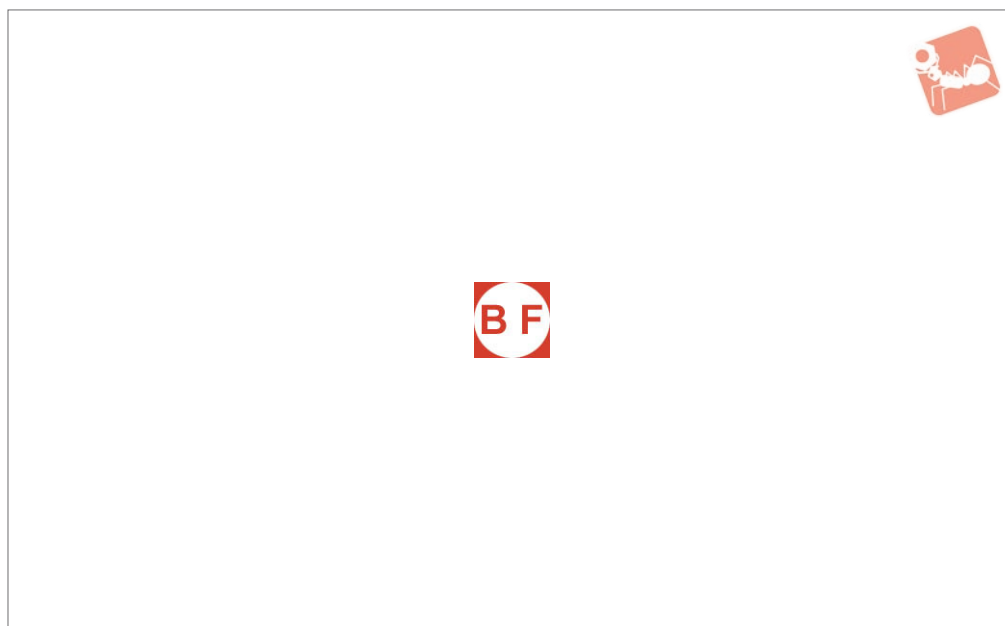

32200

SPRING PLUNGER & DETENT PINS

Material

Free cutting steel type-

Body: free cutting steel, blackened.
Pin: free cutting steel, hardened, blackened, or thermoplastic POM, white.
Spring: stainless steel.

Stainless steel type-

Body: stainless steel 1.4305 (AISI 303).
Pin: stainless steel 1.4305 (AISI 303), or thermoplastic POM, white.
Spring: stainless steel.

Technical Notes

These spring plungers may be used for

location, for applying pressure or lifting off.
Temperature range: all steel or stainless, up to 250°C.
Steel or stainless with thermoplastic pin, -30°C to +50°C.
Spring load * = statistical average value.

Tips

Spring load identifier:

Normal spring load - no marking.
Increased spring load - body marked with two lines.

These spring plungers can be assembled by

use of a hexagon key at the rear, or from the front with special slotted screwdrivers, see 32200.W0803 to .W0824.
Special types available on request.

Important Notes

All metric Wixroyd spring plungers have a coarse thread, see appendix five for thread details.

Order No.	Spring load	Finish	d ₁	d ₂	l ₁	s ₁	Spring load F ₁ N ≈	Spring load F ₂ N ≈	t ₁	w ₁	A/F	Weight g
32200.W0003	Normal	All Steel	M 3	1.0	12	1.0	2.0	4	0.5	0.4	0.7	0.40
32200.W0004	Normal	All Steel	M 4	1.5	15	1.5	4.5	16	0.6	0.6	1.3	0.93
32200.W0005	Normal	All Steel	M 5	2.4	18	2.3	6.0	19	0.8	1.2	1.5	1.70
32200.W0006	Normal	All Steel	M 6	2.7	20	2.5	6.0	19	0.9	1.3	2.0	2.80
32200.W0008	Normal	All Steel	M 8	3.5	22	3.0	10.0	39	1.4	1.5	2.5	5.80
32200.W0010	Normal	All Steel	M10	4.0	22	3.0	10.0	39	1.4	1.5	3.0	9.20
32200.W0012	Normal	All Steel	M12	6.0	28	4.0	12.0	53	2.0	2.7	4.0	16.00
32200.W0016	Normal	All Steel	M16	7.5	32	5.0	45.0	100	2.5	3.2	5.0	35.00
32200.W0020	Normal	All Steel	M20	10.0	40	7.0	52.0	125	3.0	3.7	6.0	68.00
32200.W0024	Normal	All Steel	M24	12.0	52	10.0	70.0	170	3.0	3.7	8.0	131.00
32200.W0105	Increased	All Steel	M 5	2.4	18	2.3	11.0	40	0.8	1.2	1.5	1.60
32200.W0106	Increased	All Steel	M 6	2.7	20	2.5	15.0	43	0.9	1.3	2.0	2.80
32200.W0108	Increased	All Steel	M 8	3.5	22	3.0	20.0	75	1.4	1.5	2.5	5.80
32200.W0110	Increased	All Steel	M10	4.0	22	3.0	20.0	75	1.4	1.5	3.0	9.30
32200.W0112	Increased	All Steel	M12	6.0	28	4.0	45.0	120	2.0	2.7	4.0	16.00
32200.W0116	Increased	All Steel	M16	7.5	32	5.0	64.0	160	2.5	3.2	5.0	33.00
32200.W0120	Increased	All Steel	M20	10.0	40	7.0	75.0	195	3.0	3.7	6.0	67.00
32200.W0124	Increased	All Steel	M24	12.0	52	10.0	75.0	245	3.0	3.7	8.0	129.00
32200.W0204	Normal	Steel, Thermo Pin	M 4	1.5	15	1.5	4.5	16	0.6	0.6	1.3	0.86
32200.W0205	Normal	Steel, Thermo Pin	M 5	2.4	18	2.3	6.0	19	0.8	1.2	1.5	1.50
32200.W0206	Normal	Steel, Thermo Pin	M 6	2.7	20	2.5	6.0	19	0.9	1.3	2.0	2.30
32200.W0208	Normal	Steel, Thermo Pin	M 8	3.5	22	3.0	10.0	39	1.4	1.5	2.5	5.10



Order No.	Spring load	Finish	d ₁	d ₂	l ₁	s ₁	Spring load F ₁ N ≈	Spring load F ₂ N ≈	t ₁	w ₁	A/F	Weight g
32200.W0210	Normal	Steel, Thermo Pin	M10	4.0	22	3.0	10.0	39	1.4	1.5	3.0	8.10
32200.W0212	Normal	Steel, Thermo Pin	M12	6.0	28	4.0	12.0	53	2.0	2.7	4.0	14.00
32200.W0216	Normal	Steel, Thermo Pin	M16	7.5	32	5.0	45.0	100	2.5	3.2	5.0	31.00
32200.W0404	Normal	All Stainless	M 4	1.5	15	1.5	4.5	16	0.6	0.6	1.3	1.10
32200.W0405	Normal	All Stainless	M 5	2.4	18	2.3	6.0	19	0.8	1.2	1.5	1.70
32200.W0406	Normal	All Stainless	M 6	2.7	20	2.5	6.0	19	0.9	1.3	2.0	2.80
32200.W0408	Normal	All Stainless	M 8	3.5	22	3.0	10.0	39	1.4	1.5	2.5	5.90
32200.W0410	Normal	All Stainless	M10	4.0	22	3.0	10.0	39	1.4	1.5	3.0	9.50
32200.W0412	Normal	All Stainless	M12	6.0	28	4.0	12.0	53	2.0	2.7	4.0	17.00
32200.W0416	Normal	All Stainless	M16	7.5	32	5.0	45.0	100	2.5	3.2	5.0	35.00
32200.W0420	Normal	All Stainless	M20	10.0	40	7.0	52.0	125	3.0	3.7	6.0	68.00
32200.W0604	Normal	S/S, Thermo Pin	M 4	1.5	15	1.5	4.5	16	0.6	0.6	1.3	0.93
32200.W0605	Normal	S/S, Thermo Pin	M 5	2.4	18	2.3	6.0	19	0.8	1.2	1.5	1.60
32200.W0606	Normal	S/S, Thermo Pin	M 6	2.7	20	2.5	6.0	19	0.9	1.3	2.0	2.50
32200.W0608	Normal	S/S, Thermo Pin	M 8	3.5	22	3.0	10.0	39	1.4	1.5	2.5	5.10
32200.W0610	Normal	S/S, Thermo Pin	M10	4.0	22	3.0	10.0	39	1.4	1.5	3.0	8.50
32200.W0612	Normal	S/S, Thermo Pin	M12	6.0	28	4.0	12.0	53	2.0	2.7	4.0	14.00
32200.W0616	Normal	S/S, Thermo Pin	M16	7.5	32	5.0	45.0	100	2.5	3.2	5.0	32.00
32200.W0803	Head ø2,5	Screwdriver	M 3	-	-	-	-	-	-	-	-	13.00
32200.W0804	Head ø4,0	Screwdriver	M 4	-	-	-	-	-	-	-	-	29.00
32200.W0805	Head ø5,0	Screwdriver	M 5	-	-	-	-	-	-	-	-	61.00
32200.W0806	Head ø5,5	Screwdriver	M 6	-	-	-	-	-	-	-	-	65.00
32200.W0808	Head ø7,0	Screwdriver	M 8	-	-	-	-	-	-	-	-	108.00
32200.W0810	Head ø8,0	Screwdriver	M10	-	-	-	-	-	-	-	-	124.00
32200.W0812	Head ø11,0	Screwdriver	M12	-	-	-	-	-	-	-	-	112.00
32200.W0816	Head ø14,0	Screwdriver	M16	-	-	-	-	-	-	-	-	173.00
32200.W0820	Head ø18,0	Screwdriver	M20	-	-	-	-	-	-	-	-	226.00
32200.W0824	Head ø19,9	Screwdriver	M24	-	-	-	-	-	-	-	-	258.00



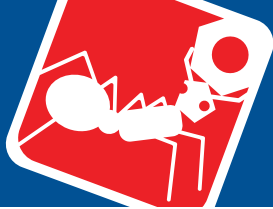

Spring Plungers

with pin end & hex socket and seal - stainless steel



Spring Plunger & Detent Pins

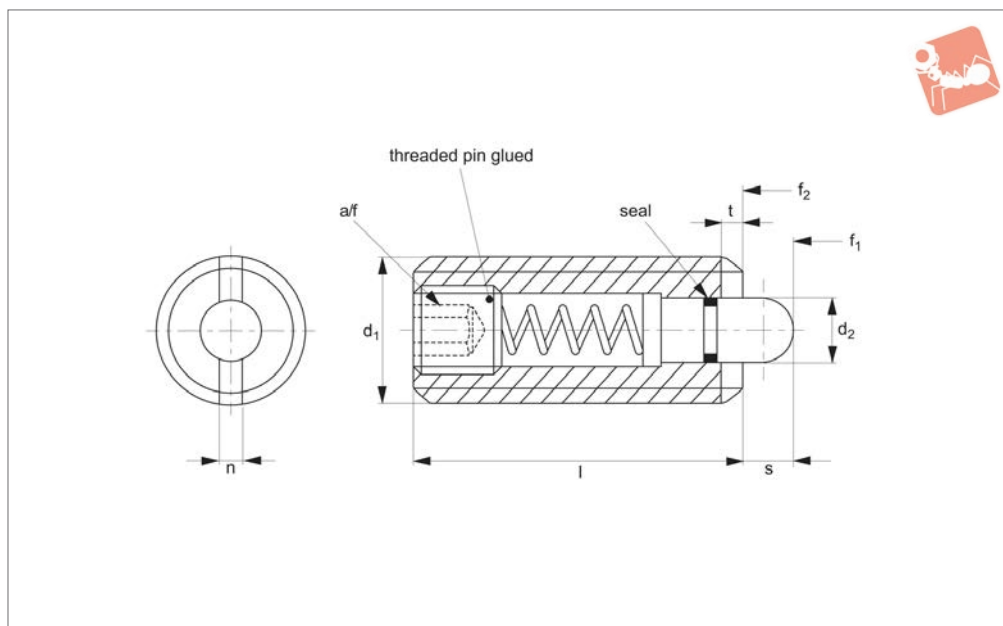

32220

SPRING PLUNGER & DETENT PINS

Material

Free cutting steel type-

Body: free cutting steel, blackened.
Pin: free cutting steel, blackened.
Spring: stainless steel. Seal NBR plastic.

Stainless steel type-

Body: stainless steel 1.4305 (AISI 303).
Pin: stainless steel 1.4305 (AISI 303).
Spring: stainless steel.
Seal: NBR plastic.

Technical Notes

These spring plungers may be used for

location, for applying pressure or lifting off. Incorporation of a seal into the design prevents liquid penetrating into the spring plunger. Temperature range -30°C to +80°C. Spring load * = statistical average value.

Tips

Spring load identifier:

Normal spring load - no marking.
Increased spring load - body marked with two lines.
Please note these items vary in dimension

l, spring load and temperature range in comparison to no-sealed item 32200. Spring plungers can be assembled by use of a hexagon key at the rear, or from the front with special slotted screwdrivers, see 32200.W0808 to .W0816. Special types available on request.

Important Notes

All metric Wixroyd spring plungers have a coarse thread, see appendix five for thread details.

Order No.	Spring load	Finish	d ₁	d ₂	l	n	s	Spring load F ₁ N ≈	Spring load F ₂ N ≈	t	A/F	Weight g
32220.W0048	Normal	All Steel	M 8	3.8	26	1.5	3.0	9	24	1.4	2.5	6.9
32220.W0050	Normal	All Steel	M10	4.0	28	1.5	3.5	15	30	1.4	3.0	11.0
32220.W0052	Normal	All Steel	M12	6.0	35	2.7	4.0	24	50	2.0	4.0	20.0
32220.W0056	Normal	All Steel	M16	7.5	40	3.2	5.0	36	58	2.5	5.0	43.0
32220.W0148	Increased	All Steel	M 8	3.8	26	1.5	3.0	17	39	1.4	2.5	6.6
32220.W0150	Increased	All Steel	M10	4.0	28	1.5	3.5	22	43	1.4	3.0	12.0
32220.W0152	Increased	All Steel	M12	6.0	35	2.7	4.0	40	80	2.0	4.0	20.0
32220.W0156	Increased	All Steel	M16	7.5	40	3.2	5.0	44	113	2.5	5.0	45.0
32220.W0448	Normal	All Stainless	M 8	3.8	26	1.5	3.0	9	24	1.4	2.5	7.2
32220.W0450	Normal	All Stainless	M10	4.0	28	1.5	3.5	15	30	1.4	3.0	12.0
32220.W0452	Normal	All Stainless	M12	6.0	35	2.7	4.0	24	50	2.0	4.0	20.0
32220.W0456	Normal	All Stainless	M16	7.5	40	3.2	5.0	36	58	2.5	5.0	44.0

Spring Plunger & Detent Pins



Spring Plungers with pin end & hex socket and seal - stainless steel



SPRING PLUNGER & DETENT PINS

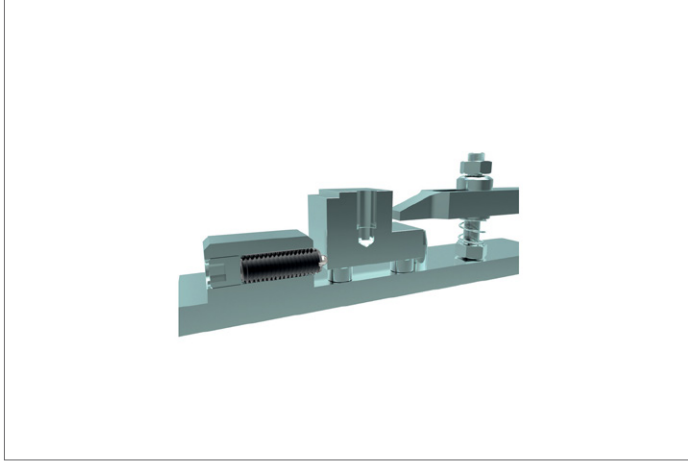



Spring Plungers

Long version

Spring Plunger & Detent Pins

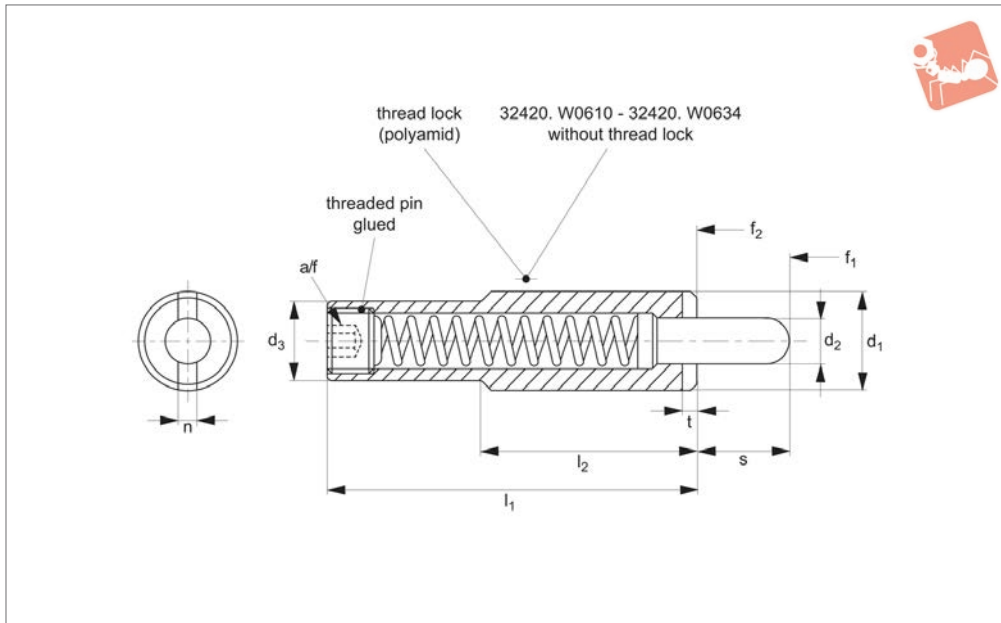

32420

SPRING PLUNGER & DETENT PINS

Material

Body: free cutting steel, blackened or heat-treated steel tempered blackened.
 Part nos. 32420.W0512 to 32420.W0580 - threaded body bright finish.
 Pin: case hardened steel, blackened.
 Spring: stainless steel.

Technical Notes

Used for ejecting parts (particularly in

press tools), and applying pressure. They are fitted/removed by means of the slot or internal hexagon.

Spring load* = statistical average value.

Tips

Spring Load Identifier:

Normal spring load - no marking.
 Increased spring load - body marked with two lines.

Parts 32420.W0408 to 32420.W0580 with thread-lock.

Important Notes

All metric Wixroyd spring plungers have a coarse thread, see appendix five for thread details.

Order No.	Spring load	d ₁	d ₂	d ₃	l ₁	l ₂	n	s	Spring load F ₁ N ≈	Spring load F ₂ N ≈	t	A/F	Weight g
32420.W0408	Normal	M10	4.0	7.8	35	25	1.5	8	6	16	1.4	3	13
32420.W0412	Normal	M12	5.5	9.5	43	35	2.7	10	4	18	2.0	4	22
32420.W0430	Normal	M16	8.0	13.4	48	35	3.2	10	7	24	3.0	6	47
32420.W0432	Normal	M16	8.0	13.4	58	35	3.2	10	15	42	3.0	6	52
32420.W0436	Normal	M16	8.0	13.4	58	35	3.2	15	9	33	3.0	6	54
32420.W0440	Normal	M16	8.0	13.4	58	35	3.2	20	4	23	3.0	6	55
32420.W0442	Normal	M16	8.0	13.4	83	35	3.2	20	11	43	3.0	6	71
32420.W0444	Normal	M16	8.0	13.4	98	35	3.2	25	13	41	3.0	6	81
32420.W0450	Normal	M16	8.0	13.4	98	35	3.2	30	13	47	3.0	6	83
32420.W0452	Normal	M16	8.0	13.4	118	35	3.2	30	24	110	3.0	6	97
32420.W0455	Normal	M16	8.0	13.4	148	35	3.2	40	13	63	3.0	6	117
32420.W0460	Normal	M16	8.0	13.4	148	35	3.2	50	7	43	3.0	6	117
32420.W0480	Normal	M24	10.0	19.6	60	45	3.7	15	14	87	3.0	8	132
32420.W0512	Increased	M12	5.5	9.5	43	35	2.7	10	7	46	2.0	4	23
32420.W0530	Increased	M16	8.0	13.4	48	35	3.2	10	10	43	3.0	6	47
32420.W0532	Increased	M16	8.0	13.4	58	35	3.2	10	14	84	3.0	6	54
32420.W0536	Increased	M16	8.0	13.4	58	35	3.2	15	10	57	3.0	6	55
32420.W0542	Increased	M16	8.0	13.4	83	35	3.2	20	18	72	3.0	6	72
32420.W0544	Increased	M16	8.0	13.4	98	35	3.2	25	20	70	3.0	6	82
32420.W0550	Increased	M16	8.0	13.4	98	35	3.2	30	20	80	3.0	6	83
32420.W0555	Increased	M16	8.0	13.4	148	35	3.2	40	21	113	3.0	6	121
32420.W0560	Increased	M16	8.0	13.4	148	35	3.2	50	13	75	3.0	6	121
32420.W0580	Increased	M24	10.0	19.6	60	45	3.7	15	24	192	3.0	8	134
32420.W0610	Normal, Heat-Treated	M16	7.3	13.4	80	35	3.2	11	17	74	3.0	8	69
32420.W0612	Normal, Heat-Treated	M16	7.3	13.4	120	35	3.2	21	21	81	3.0	8	96
32420.W0614	Normal, Heat-Treated	M16	7.3	13.4	150	35	3.2	31	21	89	3.0	8	117
32420.W0616	Normal, Heat-Treated	M16	7.3	13.4	200	35	3.2	41	16	80	3.0	8	149



Order No.	Spring load	d ₁	d ₂	d ₃	l ₁	l ₂	n	s	Spring load F ₁ N ≈	Spring load F ₂ N ≈	t	A/F	Weight g
32420.W0630	Normal, Heat-Treated	M22	9.0	19.0	130	50	3.5	21	80	214	4.0	8	211
32420.W0632	Normal, Heat-Treated	M22	9.0	19.0	168	50	3.5	31	70	210	4.0	8	278
32420.W0634	Normal, Heat-Treated	M22	9.0	19.0	226	50	3.5	41	76	208	4.0	8	358
32420.W0830	Screwdriver	for M10	-	-	-	-	-	-	-	-	-	-	87
32420.W0832	Screwdriver	for M12	-	-	-	-	-	-	-	-	-	-	88
32420.W0834	Screwdriver	for M16	-	-	-	-	-	-	-	-	-	-	110
32420.W0836	Screwdriver	for M22	-	-	-	-	-	-	-	-	-	-	245
32420.W0838	Screwdriver	for M24	-	-	-	-	-	-	-	-	-	-	258

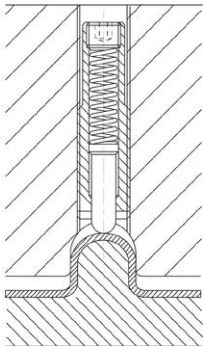



Spring Plungers - IMPERIAL

with ball and slot

Spring Plunger & Detent Pins

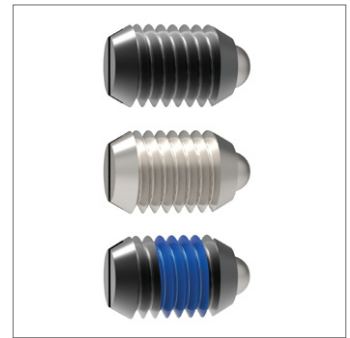
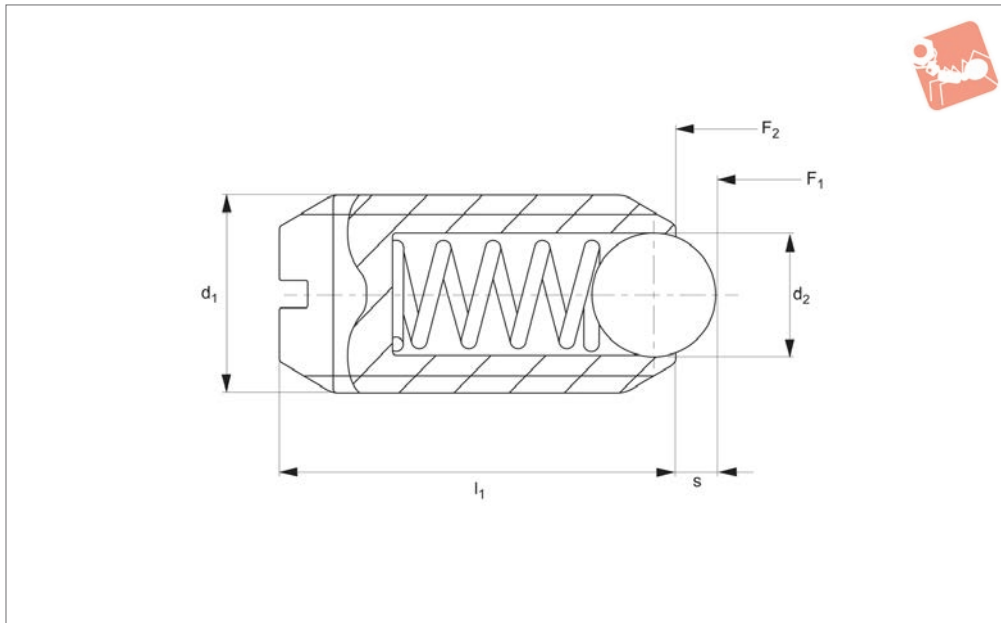

3B100

SPRING PLUNGER & DETENT PINS

Material

Free cutting steel type-

Body: free cutting steel, blackened.
Ball: ball bearing steel 1.3505 (100Cr6) hardened.
Spring: stainless steel.

Stainless steel type-

Body: stainless steel 1.4305 (AISI 303).
Ball: ball bearing steel, hardened.
Spring: stainless steel.

Technical Notes

To be used as detents or for locating, posi-

tioning, indexing, locking, latching, ejecting, lifting off and other similar push application.

Temperature range for execution without thread up to 482°F.

Thread lock - Polyamide spot coating.

Tips

Light spring load - marked with one line.

Standard spring load - no marking.

Heavy spring load - marked with two lines.

Special types available on request.

Important Notes

Spring loads are statistical average values
All dimensions are in inches

Thread: 2A-UNC/UNF.

Order No.	Type	Finish	Spring load	d ₁ UNC/UNF	l ₁ ≈	s	d ₂	Spring load f ₁ lb ≈	Spring load f ₂ lb ≈	Weight oz
3B100.W0010	w/o Threadlock	Steel	Light	UNF 10-32	33/64	0.025	3/32	0.9	1.5	0.049
3B100.W0012	w/o Threadlock	Steel	Light	UNC 1/4-20	17/32	0.035	1/8	2.1	4.0	0.074
3B100.W0016	w/o Threadlock	Steel	Light	UNC 5/16-18	37/64	0.040	5/32	2.0	4.6	0.123
3B100.W0018	w/o Threadlock	Steel	Light	UNC 3/8-16	5/8	0.048	3/16	2.5	5.0	0.193
3B100.W0020	w/o Threadlock	Steel	Light	UNC 1/2-13	3/4	0.072	9/32	3.0	6.0	0.397
3B100.W0022	w/o Threadlock	Steel	Light	UNC 5/8-11	63/64	0.096	3/8	4.5	9.0	0.787
3B100.W0031	w/o Threadlock	Steel	Standard	UNF 4-48	3/16	0.020	1/16	0.1	0.5	0.008
3B100.W0032	w/o Threadlock	Steel	Standard	UNC 5-40	1/4	0.020	1/16	0.3	0.8	0.016
3B100.W0033	w/o Threadlock	Steel	Standard	UNC 6-32	5/16	0.023	5/64	0.5	1.0	0.020
3B100.W0035	w/o Threadlock	Steel	Standard	UNF 6-40	5/16	0.023	5/64	0.5	1.0	0.020
3B100.W0036	w/o Threadlock	Steel	Standard	UNC 8-32	11/32	0.025	3/32	0.8	1.3	0.026
3B100.W0038	w/o Threadlock	Steel	Standard	UNF 8-36	11/32	0.025	3/32	0.8	1.3	0.026
3B100.W0040	w/o Threadlock	Steel	Standard	UNF 10-32	33/64	0.025	3/32	2.0	3.1	0.049
3B100.W0042	w/o Threadlock	Steel	Standard	UNC 1/4-20	17/32	0.035	1/8	3.8	6.8	0.073
3B100.W0046	w/o Threadlock	Steel	Standard	UNC 5/16-18	37/64	0.040	5/32	4.0	8.4	0.123
3B100.W0048	w/o Threadlock	Steel	Standard	UNC 3/8-16	5/8	0.048	3/16	5.0	10.3	0.198
3B100.W0050	w/o Threadlock	Steel	Standard	UNC 1/2-13	3/4	0.072	9/32	6.0	12.0	0.406
3B100.W0052	w/o Threadlock	Steel	Standard	UNC 5/8-11	63/64	0.096	3/8	9.0	18.0	0.811
3B100.W0070	w/o Threadlock	Steel	Heavy	UNF 10-32	33/64	0.025	3/32	3.3	4.8	0.049
3B100.W0072	w/o Threadlock	Steel	Heavy	UNC 1/4-20	17/32	0.035	1/8	5.6	8.6	0.073
3B100.W0076	w/o Threadlock	Steel	Heavy	UNC 5/16-18	37/64	0.040	5/32	6.0	11.1	0.122
3B100.W0078	w/o Threadlock	Steel	Heavy	UNC 3/8-16	5/8	0.048	3/16	7.5	15.1	0.196
3B100.W0080	w/o Threadlock	Steel	Heavy	UNC 1/2-13	3/4	0.072	9/32	6.0	24.0	0.408



Spring Plungers - IMPERIAL

with ball and slot



Spring Plunger & Detent Pins

Order No.	Type	Finish	Spring load	d ₁ UNC/UNF	l ₁ ≈	s	d ₂	Spring load f ₁ lb ≈	Spring load f ₂ lb ≈	Weight oz
3B100.W0370	With Threadlock	Stainless	Heavy	UNF 10-32	33/64	0.025	3/32	3.3	4.8	0.046
3B100.W0372	With Threadlock	Stainless	Heavy	UNC 1/4-20	17/32	0.35	1/8	5.6	8.6	0.074
3B100.W0376	With Threadlock	Stainless	Heavy	UNC 5/16-18	37/64	0.040	5/32	6.0	11.1	0.123
3B100.W0378	With Threadlock	Stainless	Heavy	UNC 3/8-16	5/8	0.048	3/16	7.5	15.1	0.197
3B100.W0380	With Threadlock	Stainless	Heavy	UNC 1/2-13	3/4	0.072	9/32	6.0	24.0	0.409
3B100.W0382	With Threadlock	Stainless	Heavy	UNC 5/8-11	63/64	0.096	3/8	7.0	40.0	0.825

SPRING PLUNGER & DETENT PINS

Spring Plunger & Detent Pins

Spring Plungers - IMPERIAL

with round-ended pin and slot - stainless steel or



SPRING PLUNGER & DETENT PINS



3B150

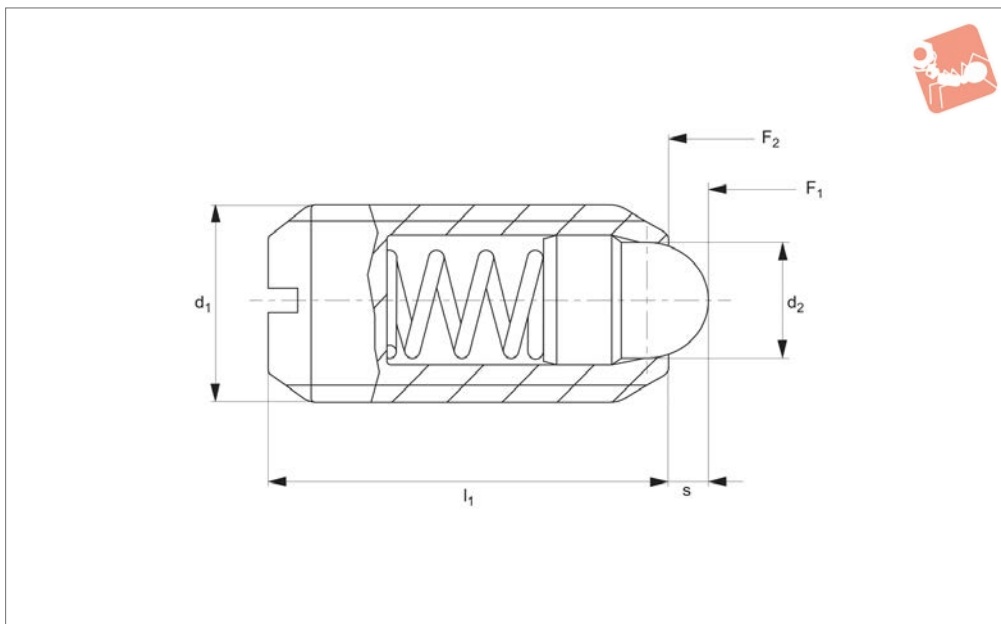

Material

Free cutting steel type-

Body: free cutting steel, blackened.

Pin: free cutting steel, hardened.

Spring: stainless steel.

Stainless steel type-

Body: stainless steel 1.4305 (AISI 303).

Pin: stainless steel 1.4305 (AISI 303).

Spring: stainless steel.

Technical Notes

To be used as detents or for locating, posi-

tioning, indexing, locking, latching, ejecting, lifting off and other similar push application.

Temperature range for execution without thread up to 482°F.

Thread lock - Polyamide spot coating.

Tips

Standard spring load = no marking

Heavy spring load = marked with two lines

Special types available on request.

Important Notes

Spring loads are statistical average values
All dimensions are in inches

Thread: 2A-UNC/UNF.

Order No.	Material	Finish	Spring load	d ₁ UNC/UNF	l ₁ ≈	s	d ₂	Spring load f ₁ lb ≈	Spring load f ₂ lb ≈	Weight oz
3B150.W0033	Steel	w/o Threadlock	Standard	UNC 6-32	3/8	0.063	0.046	0.5	1.5	0.021
3B150.W0036	Steel	w/o Threadlock	Standard	UNC 8-32	7/16	0.052	0.070	0.8	1.5	0.032
3B150.W0038	Steel	w/o Threadlock	Standard	UNF 8-36	7/16	0.052	0.070	0.8	1.5	0.032
3B150.W0040	Steel	w/o Threadlock	Standard	UNF 10-32	15/32	0.065	0.093	1.0	2.5	0.042
3B150.W0042	Steel	w/o Threadlock	Standard	UNC 1/4-20	17/32	0.078	0.119	1.1	3.5	0.074
3B150.W0046	Steel	w/o Threadlock	Standard	UNC 5/16-18	37/64	0.084	0.135	1.0	4.0	0.123
3B150.W0048	Steel	w/o Threadlock	Standard	UNC 3/8-16	5/8	0.110	0.186	1.5	4.5	0.187
3B150.W0050	Steel	w/o Threadlock	Standard	UNC 1/2-13	3/4	0.151	0.248	1.8	5.5	0.377
3B150.W0052	Steel	w/o Threadlock	Standard	UNC 5/8-11	1 1/16	0.215	0.310	2.0	8.5	0.885
3B150.W0063	Steel	w/o Threadlock	Heavy	UNC 6-32	3/8	0.063	0.046	0.5	2.5	0.018
3B150.W0066	Steel	w/o Threadlock	Heavy	UNC 8-32	7/16	0.052	0.070	1.8	4.6	0.032
3B150.W0068	Steel	w/o Threadlock	Heavy	UNF 8-36	7/16	0.052	0.070	1.8	4.6	0.032
3B150.W0070	Steel	w/o Threadlock	Heavy	UNF 10-32	15/32	0.065	0.093	2.6	6.3	0.042
3B150.W0072	Steel	w/o Threadlock	Heavy	UNC 1/4-20	17/32	0.078	0.119	3.0	9.7	0.074
3B150.W0076	Steel	w/o Threadlock	Heavy	UNC 5/16-18	37/64	0.084	0.135	3.8	13.0	0.123
3B150.W0078	Steel	w/o Threadlock	Heavy	UNC 3/8-16	5/8	0.110	0.186	4.5	16.0	0.190
3B150.W0080	Steel	w/o Threadlock	Heavy	UNC 1/2-13	3/4	0.151	0.248	5.0	22.4	0.384
3B150.W0082	Steel	w/o Threadlock	Heavy	UNC 5/8-11	1 1/16	0.215	0.310	7.0	43.5	0.907
3B150.W0133	Stainless	w/o Threadlock	Standard	UNC 6-32	3/8	0.063	0.046	0.5	1.5	0.021
3B150.W0136	Stainless	w/o Threadlock	Standard	UNC 8-32	7/16	0.052	0.070	0.8	1.5	0.032
3B150.W0138	Stainless	w/o Threadlock	Standard	UNF 8-36	7/16	0.052	0.070	0.8	1.5	0.032
3B150.W0140	Stainless	w/o Threadlock	Standard	UNF 10-32	15/32	0.065	0.093	1.0	2.5	0.042
3B150.W0142	Stainless	w/o Threadlock	Standard	UNC 1/4-20	17/32	0.078	0.119	1.1	3.5	0.074
3B150.W0146	Stainless	w/o Threadlock	Standard	UNC 5/16-18	37/64	0.084	0.135	1.0	4.0	0.123



Spring Plungers - IMPERIAL

with round-ended pin and slot - stainless steel or



Order No.	Material	Finish	Spring load	d ₁ UNC/UNF	l ₁ ≈	s	d ₂	Spring load f ₁ lb ≈	Spring load f ₂ lb ≈	Weight oz
3B150.W0148	Stainless	w/o Threadlock	Standard	UNC 3/8-16	5/8	0.110	0.186	1.5	4.5	0.190
3B150.W0150	Stainless	w/o Threadlock	Standard	UNC 1/2-13	3/4	0.151	0.248	1.8	5.5	0.388
3B150.W0152	Stainless	w/o Threadlock	Standard	UNC 5/8-11	1 1/16	0.215	0.310	2.0	8.5	0.892
3B150.W0163	Stainless	w/o Threadlock	Heavy	UNC 6-32	3/8	0.063	0.046	0.5	2.5	0.014
3B150.W0166	Stainless	w/o Threadlock	Heavy	UNC 8-32	7/16	0.052	0.070	1.8	4.6	0.032
3B150.W0168	Stainless	w/o Threadlock	Heavy	UNF 8-36	7/16	0.052	0.070	1.8	4.6	0.032
3B150.W0170	Stainless	w/o Threadlock	Heavy	UNF 10-32	15/32	0.065	0.093	2.6	6.3	0.042
3B150.W0172	Stainless	w/o Threadlock	Heavy	UNC 1/4-20	17/32	0.078	0.119	3.0	9.7	0.071
3B150.W0176	Stainless	w/o Threadlock	Heavy	UNC 5/16-18	37/64	0.084	0.135	3.8	13.0	0.123
3B150.W0178	Stainless	w/o Threadlock	Heavy	UNC 3/8-16	5/8	0.110	0.186	4.5	16.0	0.194
3B150.W0180	Stainless	w/o Threadlock	Heavy	UNC 1/2-13	3/4	0.151	0.248	5.0	22.4	0.399
3B150.W0182	Stainless	w/o Threadlock	Heavy	UNC 5/8-11	1 1/16	0.215	0.310	7.0	43.5	0.914
3B150.W0233	Steel	With Threadlock	Standard	UNC 6-32	3/8	0.063	0.046	0.5	1.5	0.021
3B150.W0236	Steel	With Threadlock	Standard	UNC 8-32	7/16	0.052	0.070	0.8	1.5	0.032
3B150.W0238	Steel	With Threadlock	Standard	UNF 8-36	7/16	0.052	0.070	0.8	1.5	0.032
3B150.W0240	Steel	With Threadlock	Standard	UNF 10-32	15/32	0.065	0.093	1.0	2.5	0.042
3B150.W0242	Steel	With Threadlock	Standard	UNC 1/4-20	17/32	0.078	0.119	1.1	3.5	0.074
3B150.W0246	Steel	With Threadlock	Standard	UNC 5/16-18	37/64	0.084	0.135	1.0	4.0	0.123
3B150.W0248	Steel	With Threadlock	Standard	UNC 3/8-16	5/8	0.110	0.186	1.5	4.5	0.187
3B150.W0250	Steel	With Threadlock	Standard	UNC 1/2-13	3/4	0.151	0.248	1.8	5.5	0.377
3B150.W0252	Steel	With Threadlock	Standard	UNC 5/8-11	1 1/16	0.215	0.310	2.0	8.5	0.885
3B150.W0263	Steel	With Threadlock	Heavy	UNC 6-32	3/8	0.063	0.046	0.5	2.5	0.018
3B150.W0266	Steel	With Threadlock	Heavy	UNC 8-32	7/16	0.052	0.070	1.8	4.6	0.032
3B150.W0268	Steel	With Threadlock	Heavy	UNF 8-36	7/16	0.052	0.070	1.8	4.6	0.032
3B150.W0270	Steel	With Threadlock	Heavy	UNF 10-32	15/32	0.065	0.093	2.6	6.3	0.042
3B150.W0272	Steel	With Threadlock	Heavy	UNC 1/4-20	17/32	0.078	0.119	3.0	9.7	0.074
3B150.W0276	Steel	With Threadlock	Heavy	UNC 5/16-18	37/64	0.084	0.135	3.8	13.0	0.123
3B150.W0278	Steel	With Threadlock	Heavy	UNC 3/8-16	5/8	0.110	0.186	4.5	16.0	0.190
3B150.W0280	Steel	With Threadlock	Heavy	UNC 1/2-13	3/4	0.151	0.248	5.0	22.4	0.384
3B150.W0282	Steel	With Threadlock	Heavy	UNC 5/8-11	1 1/16	0.215	0.310	7.0	43.5	0.907
3B150.W0333	Stainless	With Threadlock	Standard	UNC 6-32	3/8	0.063	0.046	0.5	1.5	0.021
3B150.W0336	Stainless	With Threadlock	Standard	UNC 8-32	7/16	0.052	0.070	0.8	1.5	0.032
3B150.W0338	Stainless	With Threadlock	Standard	UNF 8-36	7/16	0.052	0.070	0.8	1.5	0.032
3B150.W0340	Stainless	With Threadlock	Standard	UNF 10-32	15/32	0.065	0.093	1.0	2.5	0.042
3B150.W0342	Stainless	With Threadlock	Standard	UNC 1/4-20	17/32	0.078	0.119	1.1	3.5	0.074
3B150.W0346	Stainless	With Threadlock	Standard	UNC 5/16-18	37/64	0.084	0.135	1.0	4.0	0.123
3B150.W0348	Stainless	With Threadlock	Standard	UNC 3/8-16	5/8	0.110	0.186	1.5	4.5	0.190
3B150.W0350	Stainless	With Threadlock	Standard	UNC 1/2-13	3/4	0.151	0.248	1.8	5.5	0.388
3B150.W0352	Stainless	With Threadlock	Standard	UNC 5/8-11	1 1/16	0.215	0.310	2.0	8.5	0.892
3B150.W0363	Stainless	With Threadlock	Heavy	UNC 6-32	3/8	0.063	0.046	0.5	2.5	0.014
3B150.W0366	Stainless	With Threadlock	Heavy	UNC 8-32	7/16	0.052	0.070	1.8	4.6	0.032
3B150.W0368	Stainless	With Threadlock	Heavy	UNF 8-36	7/16	0.052	0.070	1.8	4.6	0.032
3B150.W0370	Stainless	With Threadlock	Heavy	UNF 10-32	15/32	0.065	0.093	2.6	6.3	0.042
3B150.W0372	Stainless	With Threadlock	Heavy	UNC 1/4-20	17/32	0.078	0.119	3.0	9.7	0.071
3B150.W0376	Stainless	With Threadlock	Heavy	UNC 5/16-18	37/64	0.084	0.135	3.8	13.0	0.123
3B150.W0378	Stainless	With Threadlock	Heavy	UNC 3/8-16	5/8	0.110	0.186	4.5	16.0	0.194
3B150.W0380	Stainless	With Threadlock	Heavy	UNC 1/2-13	3/4	0.151	0.248	5.0	22.4	0.399
3B150.W0382	Stainless	With Threadlock	Heavy	UNC 5/8-11	1 1/16	0.215	0.310	7.0	43.5	0.914

SPRING PLUNGER & DETENT PINS



SPRING PLUNGER & DETENT PINS

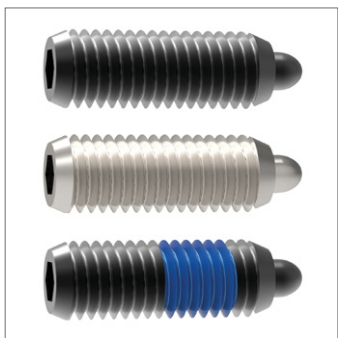

3B200

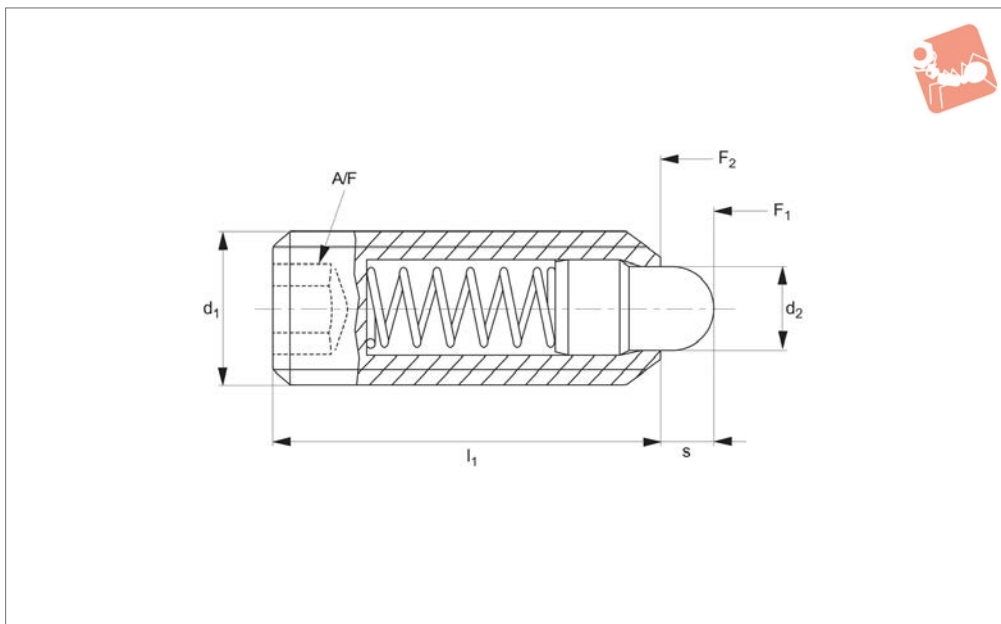

Material

Free cutting steel type-

Body: free cutting steel, blackened.

Pin: free cutting steel, hardened, blackened.

Spring: stainless steel.

Stainless steel type-

Body: stainless steel 1.4305 (AISI 303).

Pin: stainless steel 1.4305 (AISI 303).

Spring: stainless steel.

Technical Notes

To be used as detents or for locating, positioning, indexing, locking, latching, ejecting, lifting off and other similar push application.

Temperature range for execution without thread up to 482°F.

Thread lock - Polyamide spot coating.

Tips

Standard spring load = no marking

Heavy spring load = marked with two lines

Important Notes

Spring loads are statistical average values

All dimensions are in inches

Thread: 2A-UNC/UNF.

Order No.	Material	Finish	Spring load	d ₁ UNC/UNF	l ₁ ≈	s	d ₂	A/F	Spring load f ₁ lb ≈	Spring load f ₂ lb ≈	Weight oz
3B200.W0033	Steel	w/o Threadlock	Std.	UNC 6-32	17/32	0.063	0.046	1/16	0.5	1.5	0.025
3B200.W0036	Steel	With Threadlock	Std.	UNC 8-32	5/8	0.094	0.070	5/64	0.8	2.3	0.042
3B200.W0040	Steel	w/o Threadlock	Std.	UNF 10-32	3/4	0.125	0.093	3/32	1.4	2.7	0.063
3B200.W0042	Steel	With Threadlock	Std.	UNC 1/4-20	1	0.188	0.119	1/8	1.0	4.0	0.134
3B200.W0044	Steel	w/o Threadlock	Std.	UNF 1/4-28	1	0.188	0.119	1/8	1.0	4.0	0.145
3B200.W0046	Steel	With Threadlock	Std.	UNC 5/16-18	1	0.188	0.135	5/32	1.5	4.5	0.205
3B200.W0048	Steel	w/o Threadlock	Std.	UNC 3/8-16	1 1/8	0.188	0.186	3/16	2.7	7.2	0.335
3B200.W0050	Steel	With Threadlock	Std.	UNC 1/2-13	1 1/4	0.250	0.248	1/4	2.7	9.3	0.656
3B200.W0052	Steel	w/o Threadlock	Std.	UNC 5/8-11	1 1/2	0.313	0.310	5/16	3.5	10.6	1.242
3B200.W0053	Steel	With Threadlock	Std.	UNC 3/4-10	1 3/4	0.313	0.374	3/8	5.5	14.5	2.152
3B200.W0054	Steel	w/o Threadlock	Std.	UNC 1-8	2 13/32	0.500	0.499	3/8	4.0	31.0	5.443
3B200.W0063	Steel	With Threadlock	Heavy	UNC 6-32	17/32	0.063	0.046	1/16	1.5	3.4	0.026
3B200.W0066	Steel	w/o Threadlock	Heavy	UNC 8-32	5/8	0.094	0.070	5/64	2.6	6.6	0.042
3B200.W0070	Steel	With Threadlock	Heavy	UNF 10-32	3/4	0.125	0.093	3/32	3.2	9.0	0.067
3B200.W0072	Steel	w/o Threadlock	Heavy	UNC 1/4-20	1	0.188	0.119	1/8	3.1	10.1	0.134
3B200.W0074	Steel	With Threadlock	Heavy	UNF 1/4-28	1	0.188	0.119	1/8	3.1	10.1	0.145
3B200.W0076	Steel	w/o Threadlock	Heavy	UNC 5/16-18	1	0.188	0.135	5/32	3.0	15.0	0.207
3B200.W0078	Steel	With Threadlock	Heavy	UNC 3/8-16	1 1/8	0.188	0.186	3/16	5.5	12.7	0.335
3B200.W0080	Steel	w/o Threadlock	Heavy	UNC 1/2-13	1 1/4	0.250	0.248	1/4	6.6	16.0	0.649
3B200.W0082	Steel	With Threadlock	Heavy	UNC 5/8-11	1 1/2	0.313	0.310	5/16	10.5	22.2	1.245
3B200.W0083	Steel	w/o Threadlock	Heavy	UNC 3/4-10	1 3/4	0.313	0.374	3/8	6.7	33.0	2.187
3B200.W0084	Steel	With Threadlock	Heavy	UNC 1-8	2 13/32	0.500	0.499	3/8	16.0	60.0	5.538
3B200.W0133	Stainless	w/o Threadlock	Std.	UNC 6-32	17/32	0.063	0.046	1/16	0.5	1.5	0.018
3B200.W0136	Stainless	With Threadlock	Std.	UNC 8-32	5/8	0.094	0.070	5/64	0.8	2.3	0.039
3B200.W0140	Stainless	w/o Threadlock	Std.	UNF 10-32	3/4	0.125	0.093	3/32	1.4	2.7	0.063
3B200.W0142	Stainless	With Threadlock	Std.	UNC 1/4-20	1	0.188	0.119	1/8	1.0	4.0	0.131



Wixroyd have applied their extensive experience and expertise in spring plunger design and production to offer a range of imperial plungers.

At Last – Imperial Version Spring Plungers Stocked in the UK!

Spring Loads

Three available spring pressure models.

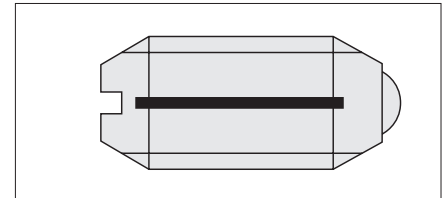
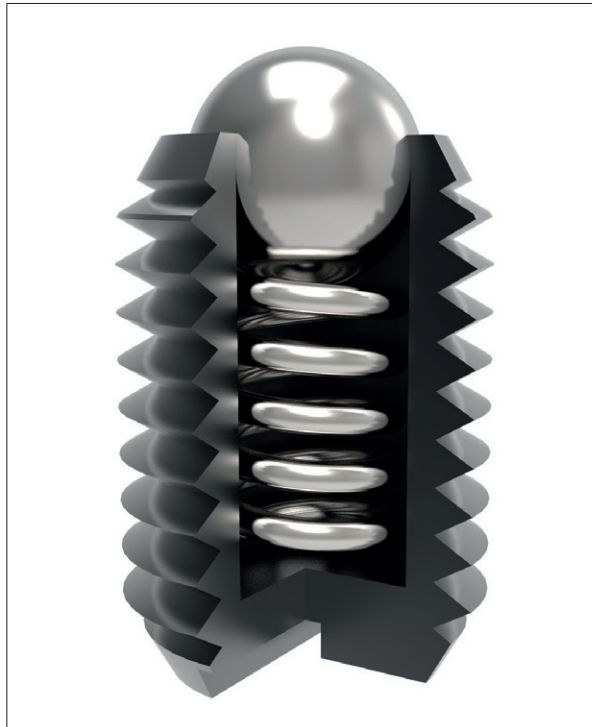

Light spring load = marked with one line.

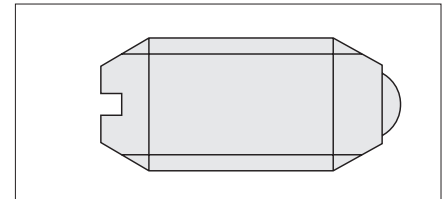

Standard spring load = no marking.

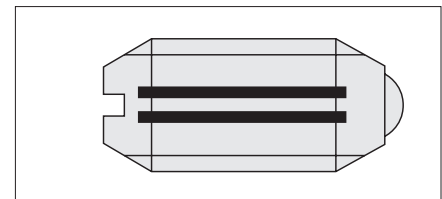

Heavy spring load = marked with two lines.

Thread Details

2A-UNC/UNF: sizes 4-48 to 5/8-11.

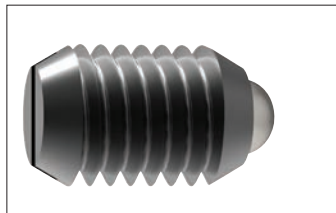

3B100 Imperial plunger with ball and slot.

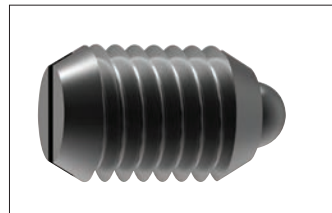

3B150 Imperial plunger with pin and slot.

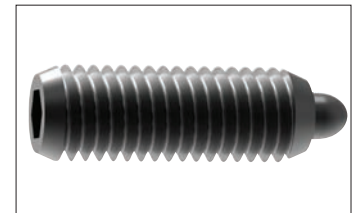

3B200 Imperial plunger with pin and hex socket.

Conversion table: Metric/Imperial values

	To convert from	To	Use conversion factor
Lengths	Inch (in)	Millimeter (mm)	in x 25,4 = mm
	Millimeter (mm)	Inch (in)	mm x 0,03937 = in
Weight/force	Ounces (oz)	Gram (g)	oz x 28 = g
	Gram (g)	Ounces (oz)	g x 0,035 = oz
	Pounds (lbs)	Kilogram (Kg)	lbs x 0,4536 = Kg
	Kilogram (Kg)	Pounds (lbs)	Kg x 2,205 = lbs
	Kilogram (Kg)	Newton (N)	Kg x 9,81 = N
Temperature	Degree fahrenheit (°F)	Degree centigrade (°C)	(°F-32) x 5/9 = °C
	Degree centigrade (°C)	Degree fahrenheit (°F)	°C x 9/5 + 32 = °F
Torque	Foot-pounds (ft-lbs)	Newton-meter (Nm)	ft/lbs x 1,35 = Nm
	Newton-meter (Nm)	Foot-pounds (ft-lbs)	Nm x 0,74 = ft/lbs

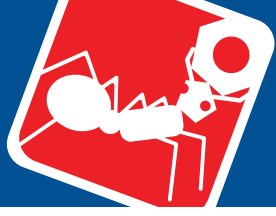

We recommend a cutting speed of between 10 and 20m/min.

Therefore typical value for chamfers of varying diameter are as follows.

Diameter	RPM range
10 mm	320 to 640 rpm
15 mm	210 to 420 rpm
20 mm	160 to 320 rpm
30 mm	110 to 220 rpm
40 mm	80 to 160 rpm
50 mm	55 to 110 rpm

We do however recommend you use the following formula to check the most suitable rpm used.

$$\text{Rpm} = (\text{cutting speed} \times 1000) / (\text{diameter} \times 3.14)$$

Blade cutting angle	0°	14°	20°	25°
Suitable for material	Brass, bronze, cast iron, stainless steel	Steel, special bronze, perspex	Soft steel, copper, AU 4G, plastic, stainless steel	Aluminium, soft iron, sheet metal

Important Note:
 We recommend the chamfering tool is lubricated with cutting fluid or soluble oil to ensure the long life of the cutting blade edge, and to reduce wear of the pilot cone.
 We offer blades with a variety of cutting angles to best suit the material in which a chamfer is required.
 Typically a blade cutting angle of 14° suits most applications; please refer to table above.

Recommended Cutting Speed

Typical rpm for varying chamfer diameters, when using cutting speed of between 10 and 20 m/min.



31000

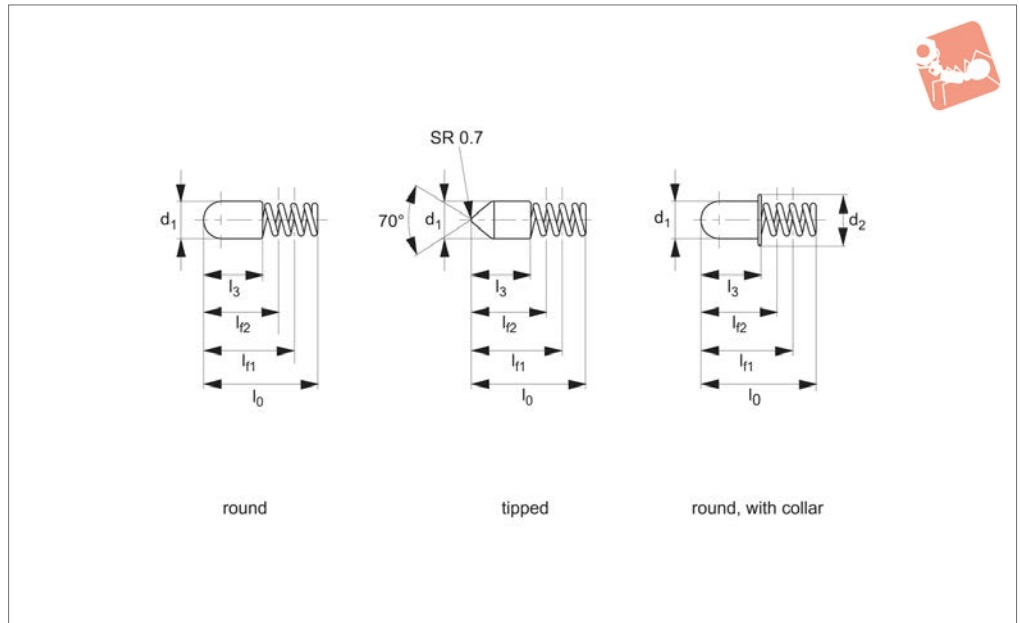

Material

Body: steel, nickel-plated.
 Stainless steel 1.4303 (AISI 305). Brass,
 nickel-plated.
 Spring: stainless steel 1,4310 (AISI 301).

Technical Notes

Max. temperature 250°C. Spring load * =
 statistical average.

Tips

To be used for locating or as a detent.
 Special springs available on request.

Order No.	Type	Finish	d ₁ ±0.05	l ₀	d ₂	l ₃	l _{f1}	l _{f2}	Spring load F ₁ N ≈	Spring load F ₂ N ≈	R N/mm	Weight g
31000.W0012	Round	Steel	2.2	16	-	7.8	12.0	10.5	2.2	3.0	0.53	0.13
31000.W0016	Round	Steel	2.6	8	-	3.8	6.5	5.2	1.1	2.0	0.70	0.07
31000.W0022	Round	Steel	3.0	12	-	6.0	9.0	8.7	6.2	6.8	2.00	0.18
31000.W0024	Round	Steel	3.0	16	-	8.5	13.0	10.7	4.8	8.4	1.60	0.23
31000.W0034	Round	Steel	3.4	12	-	6.0	9.0	7.8	5.0	7.0	1.69	0.18
31000.W0036	Round	Steel	3.4	15	-	7.3	12.0	8.2	5.9	13.3	1.95	0.22
31000.W0042	Round	Steel	4.0	14	-	8.0	12.0	9.0	5.0	12.3	2.45	0.41
31000.W0052	Round	Steel	5.0	16	-	8.0	13.0	10.4	8.0	15.0	2.70	0.59
31000.W0124	Round	Stainless	3.0	16	-	8.0	13.0	10.6	4.8	8.6	1.60	0.22
31000.W0137	Round	Stainless	3.6	18	-	9.0	15.0	11.5	6.7	14.5	2.24	0.36
31000.W0144	Round	Stainless	4.0	16	-	7.5	13.0	11.4	8.0	12.3	2.70	0.37
31000.W0212	Tipped	Steel	2.2	16	-	7.8	12.0	10.5	2.2	3.0	0.53	0.12
31000.W0222	Tipped	Steel	3.0	11	-	5.0	9.0	6.7	1.6	3.4	0.78	0.11
31000.W0224	Tipped	Steel	3.0	16	-	8.5	13.0	10.7	4.8	8.4	1.60	0.23
31000.W0373	Round, with Collar	Stainless	3.0	13	4.1	7.0	10.0	8.9	5.3	7.2	1.75	0.19



Spring Bodies

steel or stainless steel



Spring Plunger & Detent Pins

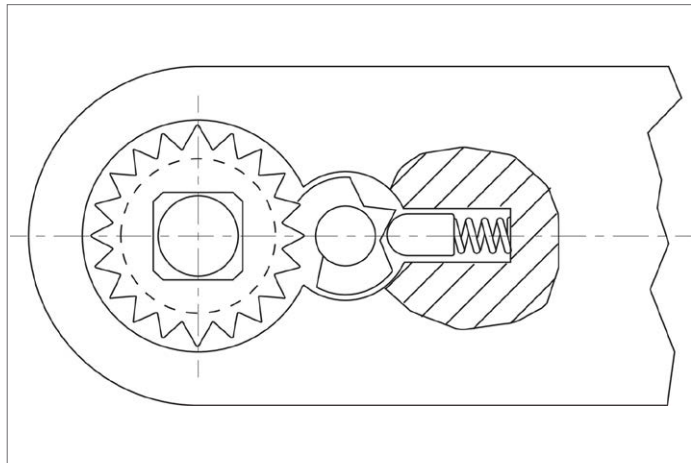



32800

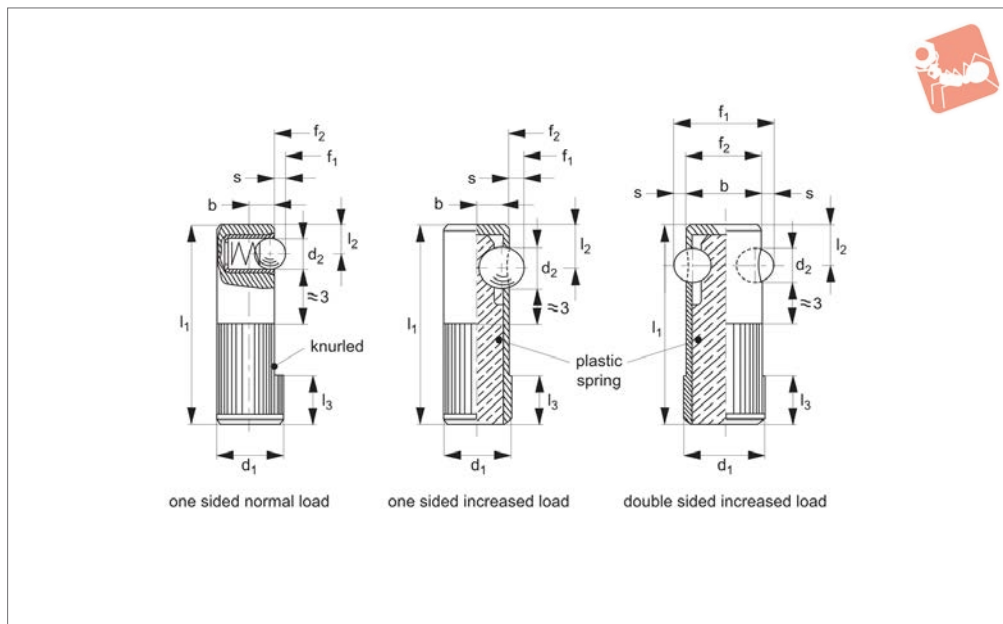

Material

Body: free cutting steel, blackened.
 Ball: ball bearing steel 1.3505 (100Cr6) hardened, stainless steel, hardened or Thermoplastic white (POM).
 Spring: stainless steel or plastic (PU).

Technical Notes

The lateral spring plunger must be inserted into a bore to measure at least l_3 . Positions and applies pressure. Spring loads * = statistical average values.

Tips

When storing the fixtures, no pressure should be applied to the plastic spring.

Order No.	Ball type	Spring load	d_1 +0.1	d_2	l_1	l_2	l_3	b	Location hole tol. H8	s	Spring load F_1 N ≈	Spring load F_2 N ≈	Temperature °C max.	Weight g
32800.W0008	Stainless, One	Normal	8	3,0	25	3,6	6	3,2	8	0,8	2,5	6,5	-30/+50	9
32800.W0010	Stainless, One	Normal	10	4,0	30	4,2	7	4,0	10	1,0	4,5	9,0	-30/+50	17
32800.W0012	Stainless, One	Normal	12	5,0	35	4,8	9	5,0	12	1,6	6,5	13,0	-30/+50	29
32800.W0014	Stainless, One	Normal	14	6,5	40	5,8	10	5,4	14	1,9	8,0	18,0	-30/+50	43
32800.W0108	Thermo, One	Normal	8	3,0	25	3,6	6	3,2	8	0,8	2,5	6,5	-30/+50	9
32800.W0110	Thermo, One	Normal	10	4,0	30	4,2	7	4,0	10	1,0	4,5	9,0	-30/+50	17
32800.W0112	Thermo, One	Normal	12	5,0	35	4,8	9	5,0	12	1,6	6,5	13,0	-30/+50	28
32800.W0114	Thermo, One	Normal	14	6,5	40	5,8	10	5,4	14	1,9	8,0	18,0	-30/+50	42
32800.W0410	Steel, One	Increased	10	5,5	30	7,0	8	4,5	10	1,0	60,0	170,0	-40/+80	9
32800.W0412	Steel, One	Increased	12	6,5	35	8,0	9	5,5	12	1,5	80,0	260,0	-40/+80	14
32800.W0414	Steel, One	Increased	14	8,0	40	9,0	10	6,5	14	2,0	120,0	480,0	-40/+80	20
32800.W0616	Steel, Double	Increased	16	5,5	35	7,0	11	15,0	16	1,5	110,0	220,0	-40/+80	21
32800.W0618	Steel, Double	Increased	18	6,5	40	8,0	12	17,0	18	1,8	120,0	330,0	-40/+80	27
32800.W0622	Steel, Double	Increased	22	8,0	45	9,0	15	21,0	22	2,5	130,0	540,0	-40/+80	45

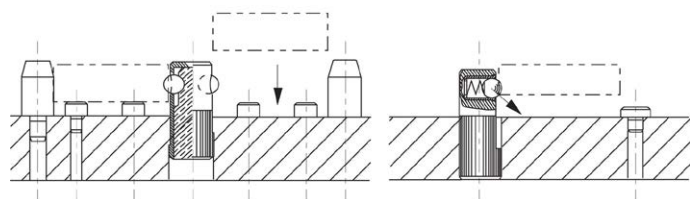
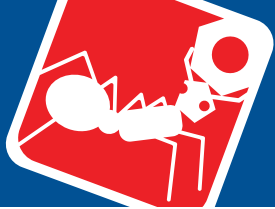

SPRING PLUNGER & DETENT PINS



32810

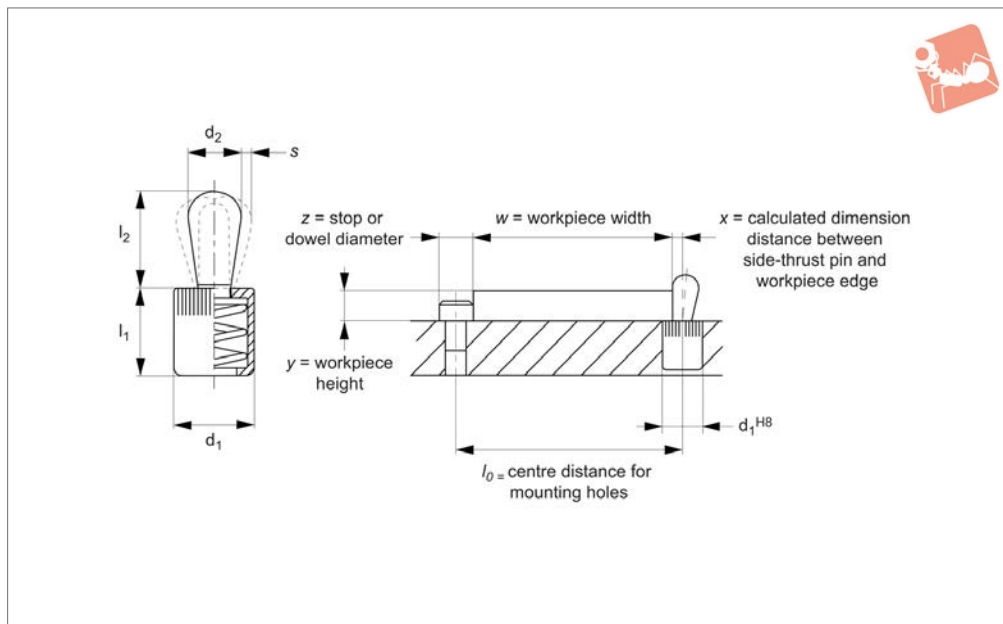

Material

Body: aluminium.

Pin: steel, case hardened and galvanized, or thermoplastic (POM) white.

Spring: steel (blackened or blue galvanized), or stainless steel.

Technical Notes

Press fit installation into hole d_1 to tol. H8, using fitting tool (order separately).

Installation calculations;

A) Calculating centre distance for mounting holes (l_0);

$$l_0 = (z/2) + w + x$$

B) Calculating pin location (x);

When workpiece height (y) is greater than or equal to $l_2 - (d_2/2)$ then (x) is calculated as; $x = (d_2/2) - s$

When workpiece height (y) is less than

$l_2 - (d_2/2)$ then (x) is calculated as;

$$x = (d_2/2) - s - \{ [l_2 - (d_2/2) - y] * 0.123 \}$$

l_0 = centre distance for mounting holes

y = workpiece height

w = workpiece width

x = distance between side-thrust pin and workpiece edge

workpiece edge

s = stroke

z = stop or dowel stop diameter

Tips

Side-thrust pins are ideal for holding, clamping and positioning parts.

Spring colour gives visual indication of spring pressure (N).

Light spring load = natural stainless steel spring.

Standard spring load = steel spring, blackened.

Heavy spring load = steel spring, blue galvanized.

Order No.	Pin material	Spring load	d_1	d_2	l_1 -1	l_2 ± 0.5	Location hole d_1 tol. H8	Spring colour	Spring pressure N	Stroke s	Temp. resistance $^{\circ}\text{C}$ max.	Fitting tool 32810	Weight g
32810.W0001	Steel Pin	Light	6	3	7	4,0	6	S/S	10	0,5	250	.W0830	1
32810.W0002	Steel Pin	Standard	6	3	7	4,0	6	Black	20	0,5	250	.W0830	1
32810.W0003	Steel Pin	Heavy	6	3	7	4,0	6	Blue	40	0,5	250	.W0830	1
32810.W0004	Steel Pin	Light	10	5	11	6,7	10	S/S	20	0,8	250	.W0831	3
32810.W0005	Steel Pin	Standard	10	5	11	6,7	10	Black	50	0,8	250	.W0831	3
32810.W0006	Steel Pin	Heavy	10	5	11	6,7	10	Blue	100	0,8	250	.W0831	3
32810.W0007	Steel Pin	Light	10	6	11	10,7	10	S/S	40	1,0	250	.W0831	4
32810.W0008	Steel Pin	Standard	10	6	11	10,7	10	Black	75	1,0	250	.W0831	4
32810.W0009	Steel Pin	Heavy	10	6	11	10,7	10	Blue	150	1,0	250	.W0831	4
32810.W0010	Steel Pin	Light	12	8	13	13,9	12	S/S	50	1,3	250	.W0832	7
32810.W0011	Steel Pin	Standard	12	8	13	13,9	12	Black	100	1,3	250	.W0832	7
32810.W0012	Steel Pin	Heavy	12	8	13	13,9	12	Blue	200	1,3	250	.W0832	7
32810.W0013	Steel Pin	Light	16	10	17	16,7	16	S/S	100	1,6	250	.W0833	15
32810.W0014	Steel Pin	Standard	16	10	17	16,7	16	Black	200	1,6	250	.W0833	15
32810.W0015	Plastic Pin	Heavy	16	10	17	16,7	16	Blue	300	1,6	80	.W0833	15
32810.W0404	Plastic Pin	Heavy	10	5	11	6,7	10	S/S	20	0,8	80	.W0831	1
32810.W0407	Plastic Pin	Standard	10	6	11	10,7	10	S/S	40	1,0	80	.W0831	2
32810.W0410	Plastic Pin	Light	12	8	13	13,9	12	S/S	50	1,3	80	.W0832	3
32810.W0413	Plastic Pin	Heavy	16	10	17	16,7	16	S/S	100	1,6	80	.W0833	7



Side-Thrust Pins without seal



Spring Plunger & Detent Pins

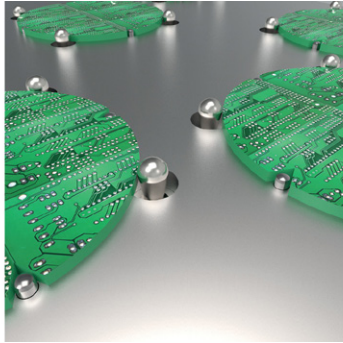



32820

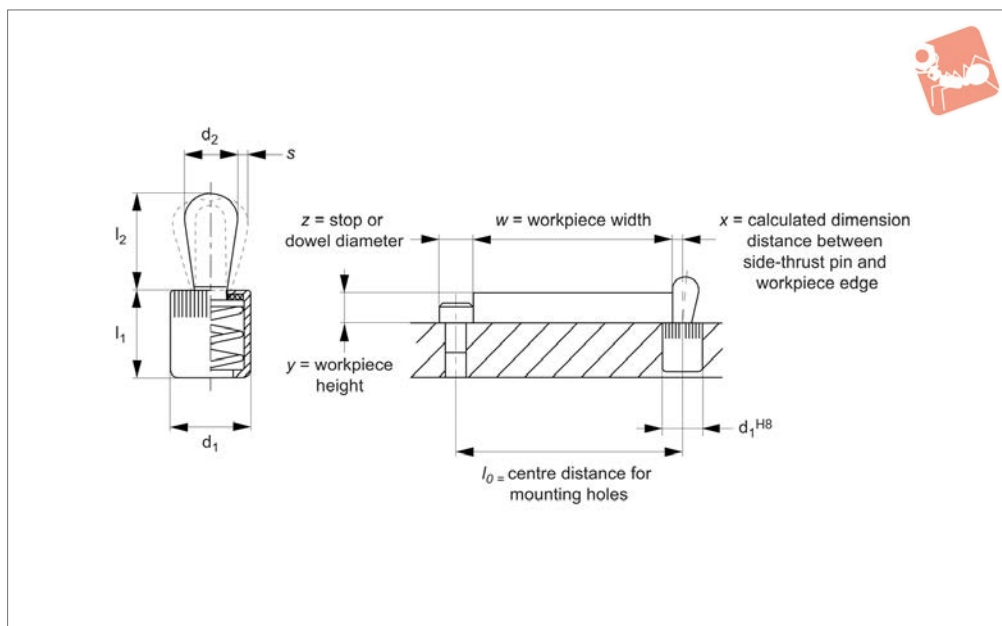

Material

Body: aluminium.
 Pin: steel, case hardened and galvanized, or thermoplastic (POM) white.
 Spring: steel (blackened or blue galvanized), or stainless steel.
 Seal: rubber (CR), 60 shore.

Technical Notes

Press fit installation into hole d_1 to tol. H8, using fitting tool (order separately).
 Installation calculations;
 A) Calculating centre distance for mounting holes (l_0);
 $l_0 = (z/2) + w + x$

B) Calculating pin location (x);
 When workpiece height (y) is greater than or equal to $l_2 - (d_2/2)$ then (x) is calculated as;
 $x = (d_2/2) - s$

When workpiece height (y) is less than $l_2 - (d_2/2)$ then (x) is calculated as;
 $x = (d_2/2) - s - \{ [l_2 - (d_2/2) - y] * 0.123 \}$

l_0 = centre distance for mounting holes
 y = workpiece height
 w = workpiece width
 x = distance between side-thrust pin and

workpiece edge
 s = stroke
 z = stop or dowel stop diameter

Tips

Side-thrust pins are ideal for holding, clamping and positioning parts.
Spring colour gives visual indication of spring pressure (N).
 Light spring load = natural stainless spring.
 Standard spring load = steel spring, blackened.
 Heavy spring load = steel spring, blue galvanized.

Order No.	Pin material	Spring load	d_1	d_2	l_1 -1	l_2 ± 0.5	Location hole d_1 tol. H8	Spring colour	Spring pressure N	Stroke s	Temp. resistance $^{\circ}\text{C}$ max.	Fitting tool 32810	Weight g
32820.W0001	Steel Pin	Light	6	3	7	4	6	S/S	10	0,5	110	.W0830	1
32820.W0002	Steel Pin	Standard	6	3	7	4	6	Black	20	0,5	110	.W0830	1
32820.W0003	Steel Pin	Heavy	6	3	7	4	6	Blue	40	0,5	110	.W0830	1
32820.W0004	Steel Pin	Light	10	5	12	6	10	S/S	20	0,8	110	.W0831	3
32820.W0005	Steel Pin	Standard	10	5	12	6	10	Black	50	0,8	110	.W0831	3
32820.W0006	Steel Pin	Heavy	10	5	12	6	10	Blue	100	0,8	110	.W0831	3
32820.W0007	Steel Pin	Light	10	6	12	10	10	S/S	40	1,0	110	.W0831	4
32820.W0008	Steel Pin	Standard	10	6	12	10	10	Black	75	1,0	110	.W0831	4
32820.W0009	Steel Pin	Heavy	10	6	12	10	10	Blue	150	1,0	110	.W0831	4
32820.W0010	Steel Pin	Light	12	8	14	13	12	S/S	50	1,3	110	.W0832	7
32820.W0011	Steel Pin	Standard	12	8	14	13	12	Black	100	1,3	110	.W0832	7
32820.W0012	Steel Pin	Heavy	12	8	14	13	12	Blue	200	1,3	110	.W0832	8
32820.W0013	Steel Pin	Light	16	10	18	16	16	S/S	100	1,6	110	.W0833	15
32820.W0014	Steel Pin	Standard	16	10	18	16	16	Black	200	1,6	110	.W0833	15
32820.W0015	Steel Pin	Heavy	16	10	18	16	16	Blue	300	1,6	110	.W0833	16
32820.W0401	Plastic Pin	Light	6	3	7	4	6	S/S	10	0,5	80	.W0830	1
32820.W0404	Plastic Pin	Light	10	5	12	6	10	S/S	20	0,8	80	.W0831	1
32820.W0407	Plastic Pin	Light	10	6	12	10	10	S/S	40	1,0	80	.W0831	2
32820.W0410	Plastic Pin	Light	12	8	14	13	12	S/S	50	1,3	80	.W0832	3
32820.W0413	Plastic Pin	Light	16	10	18	16	16	S/S	100	1,6	80	.W0833	7



Side-Thrust Pins - Without Seal

for use with pins of your own design

Spring Plunger & Detent Pins

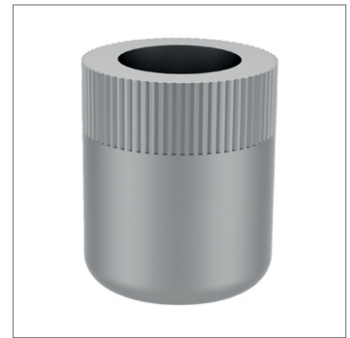
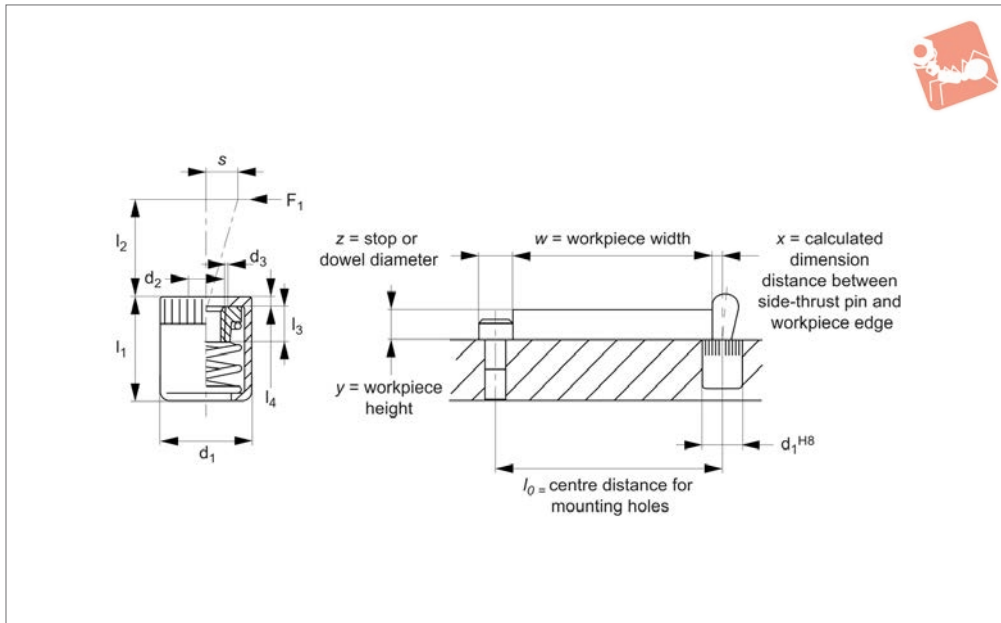

32830.1

SPRING PLUNGER & DETENT PINS

Material

Body: aluminium.
 Threaded Washer: steel, blackened.
 Spring: steel (blackened or blue galvanized), or stainless steel.

Technical Notes

Press fit installation into hole d_1 to tol. H8, using fitting tool (order separately).

Installation calculations;

A) Calculating centre distance for mounting holes (l_0);

$$l_0 = (z/2) + w + x$$

B) Calculating pin location (x);

When workpiece height (y) is greater than or equal to $l_2 - (d_2/2)$ then (x) is calculated as; $x = (d_2/2) - s$

When workpiece height (y) is less than $l_2 - (d_2/2)$ then (x) is calculated as; $x = (d_2/2) - s - \{ [l_2 - (d_2/2) - y] * 0.123 \}$

l_0 = centre distance for mounting holes
 y = workpiece height

w = workpiece width
 x = distance between side-thrust pin and workpiece edge

s = stroke

z = stop or dowel stop diameter

Tips

Side-thrust pins are ideal for holding, clamping and positioning parts.

Spring colour gives visual indication of spring pressure (N).

Light spring load = natural stainless spring.

Standard spring load = steel spring, blackened.

Heavy spring load = steel spring, blue galvanized.

Order No.	Spring load	d_1	d_2	d_3	l_1 -1	l_2	l_3	Weight g
32830.W0001	Light	10	M 4	6.3	11	2.5	4.5	2
32830.W0002	Standard	10	M 4	6.3	11	2.5	4.5	2
32830.W0003	Heavy	10	M 4	6.3	11	2.5	4.5	2
32830.W0004	Light	10	M 4	6.3	11	7.5	4.5	2
32830.W0005	Standard	10	M 4	6.3	11	7.5	4.5	2
32830.W0006	Heavy	10	M 4	6.3	11	7.5	4.5	3
32830.W0007	Light	16	M 6	10.3	18	11.5	7.5	9
32830.W0008	Standard	16	M 6	10.3	18	11.5	7.5	9
32830.W0009	Heavy	16	M 6	10.3	18	11.5	7.5	9

Order No.	l_4	Location hole d_1 tol. H8	Spring colour	Spring pressure N	Stroke s	Temp. resistance °C max.	Fitting tool 32810
32830.W0001	1.2	10	S/S	20	1.6	250	.W0831
32830.W0002	1.2	10	Black	50	1.6	250	.W0831
32830.W0003	1.2	10	Blue	100	1.6	250	.W0831
32830.W0004	1.2	10	S/S	40	2.0	250	.W0831
32830.W0005	1.2	10	Black	75	2.0	250	.W0831
32830.W0006	1.2	10	Blue	100	2.0	250	.W0831
32830.W0007	1.7	16	S/S	100	3.2	250	.W0833
32830.W0008	1.7	16	Black	150	3.2	250	.W0833

Spring Plunger & Detent Pins

Side-Thrust Pins - Without Seal for use with pins of your own design



Order No.	l_4	Location hole d_1 tol. H8	Spring colour	Spring pressure N	Stroke s	Temp. resistance °C max.	Fitting tool 32810
32830.W0009	1.7	16	Blue	200	3.2	250	.W0833

SPRING PLUNGER & DETENT PINS

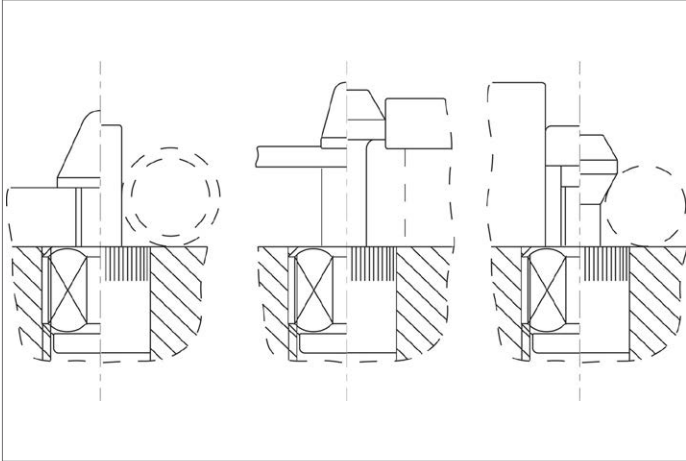



Side-Thrust Pins - With Seal

for use with pins of your own design

Spring Plunger & Detent Pins

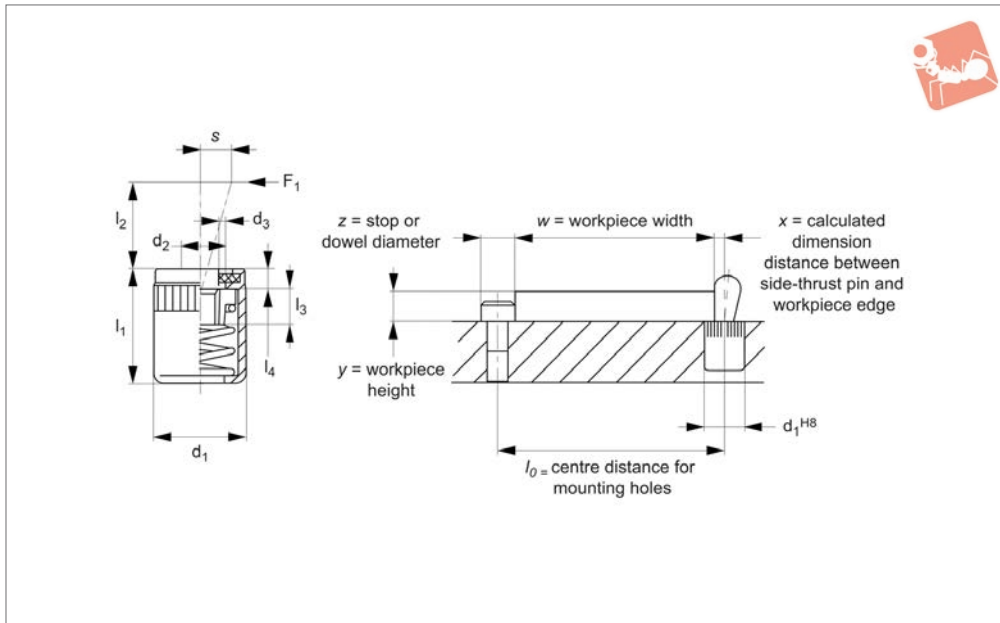

32830.2

SPRING PLUNGER & DETENT PINS

Material

Body: aluminium.
 Threaded Washer: steel, blackened.
 Spring: steel (blackened or blue galvanized), or stainless steel.
 Seal: rubber (CR), 60 shore.

Technical Notes

Press fit installation into hole d_1 to tol. H8, using fitting tool (order separately).
 Installation calculations:
 A) Calculating centre distance for mounting holes (l_0):
 $l_0 = (z/2) + w + x$

B) Calculating pin location (x);

When workpiece height (y) is greater than or equal to $l_2 - (d_2/2)$ then (x) is calculated as;
 $x = (d_2/2) - s$

When workpiece height (y) is less than $l_2 - (d_2/2)$ then (x) is calculated as;
 $x = (d_2/2) - s - \{ [l_2 - (d_2/2) - y] * 0.123 \}$

l_0 = centre distance for mounting holes
 y = workpiece height
 w = workpiece width
 x = distance between side-thrust pin and

workpiece edge
 s = stroke
 z = stop or dowel stop diameter

Tips

Side-thrust pins are ideal for holding, clamping and positioning parts.
Spring colour gives visual indication of spring pressure (N).
 Light spring load = natural stainless spring.
 Standard spring load = steel spring, blackened.
 Heavy spring load = steel spring, blue galvanized.

Order No.	Spring load	d_1	d_2	d_3	l_1 -2	l_2	l_3	Weight g
32830.W0401	Light	10	M 4	6.3	11	2.5	4.5	2
32830.W0402	Standard	10	M 4	6.3	11	2.5	4.5	2
32830.W0403	Heavy	10	M 4	6.3	11	2.5	4.5	2
32830.W0404	Light	10	M 4	6.3	11	7.5	4.5	2
32830.W0405	Standard	10	M 4	6.3	11	7.5	4.5	2
32830.W0406	Heavy	10	M 4	6.3	11	7.5	4.5	3
32830.W0407	Light	16	M 6	10.3	18	11.5	7.5	9
32830.W0408	Standard	16	M 6	10.3	18	11.5	7.5	9
32830.W0409	Heavy	16	M 6	10.3	18	11.5	7.5	9

Order No.	l_4	Location hole d_1 tol. H8	Spring colour	Spring pressure N	Stroke s	Temp. resistance °C max.	Fitting tool 32810
32830.W0401	1.8	10	S/S	20	1.6	110	.W0831
32830.W0402	1.8	10	Black	50	1.6	110	.W0831
32830.W0403	1.8	10	Blue	100	1.6	110	.W0831
32830.W0404	1.8	10	S/S	40	2.0	110	.W0831
32830.W0405	1.8	10	Black	75	2.0	110	.W0831
32830.W0406	1.8	10	Blue	100	2.0	110	.W0831
32830.W0407	2.0	16	S/S	100	3.2	110	.W0833
32830.W0408	2.0	16	Black	150	3.2	110	.W0833

Spring Plunger & Detent Pins

Side-Thrust Pins - With Seal for use with pins of your own design



Order No.	l_4	Location hole d_1 tol. H8	Spring colour	Spring pressure N	Stroke s	Temp. resistance °C max.	Fitting tool 32810
32830.W0409	2.0	16	Blue	200	3.2	110	.W0833

SPRING PLUNGER & DETENT PINS

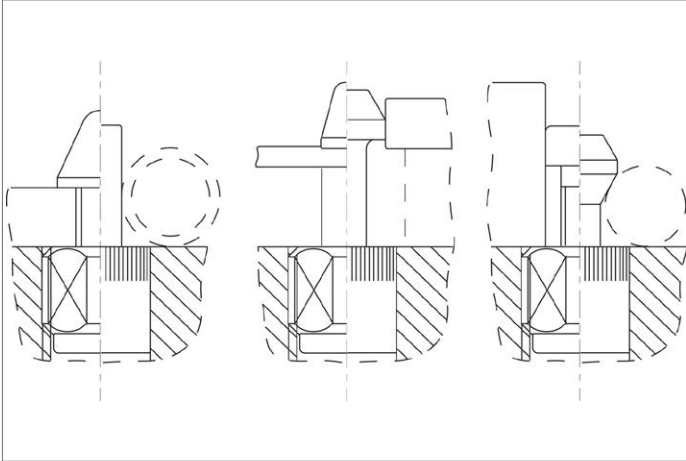



Side-Thrust Pins - Threaded without seal

Spring Plunger & Detent Pins

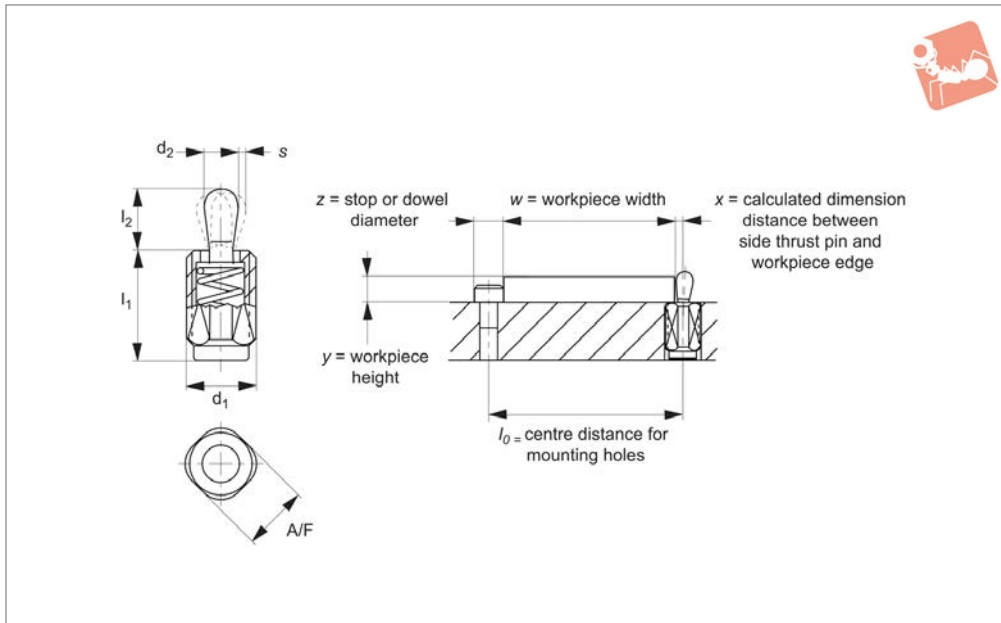

32840

SPRING PLUNGER & DETENT PINS

Material

Body: aluminium.
Pin: steel, case hardened and galvanized, or thermoplastic (POM) white.
Spring: steel (blackened or blue galvanized), or stainless steel.

Technical Notes

Press fit installation into hole d_1 to tol. H8, using fitting tool (order separately).
Installation calculations;

A) Calculating centre distance for mounting holes (l_0):
 $l_0 = (z/2) + w + x$

B) Calculating pin location (x):
When workpiece height (y) is greater than or equal to $l_2 - (d_2/2)$ then (x) is calculated as; $x = (d_2/2) - s$
When workpiece height (y) is less than $l_2 - (d_2/2)$ then (x) is calculated as;
 $x = (d_2/2) - s - \{ [l_2 - (d_2/2) - y] * 0.123 \}$

l_0 = centre distance for mounting holes
 y = workpiece height
 w = workpiece width
 x = distance between side-thrust pin and workpiece edge

s = stroke
 z = stop or dowel stop diameter

Tips

Side-thrust pins are ideal for holding, clamping and positioning parts.
Spring colour gives visual indication of spring pressure (N).
Light spring load = natural stainless steel spring.
Standard spring load = steel spring, blackened.
Heavy spring load = steel spring, blue galvanized.

Order No.	Pin material	Spring load	d_1	d_2	l_{-2}	Weight g
32840.W0001	Steel pin	Light	M12	5	11.5	4
32840.W0002	Steel pin	Light	M12	5	19.0	6
32840.W0003	Steel pin	Light	M12	5	26.5	8
32840.W0004	Steel pin	Standard	M12	5	11.5	4
32840.W0005	Steel pin	Standard	M12	5	19.0	6
32840.W0006	Steel pin	Standard	M12	5	26.5	8
32840.W0007	Steel pin	Heavy	M12	5	11.5	4
32840.W0008	Steel pin	Heavy	M12	5	19.0	7
32840.W0009	Steel pin	Heavy	M12	5	26.5	9
32840.W0010	Steel pin	Light	M12	6	11.5	5
32840.W0011	Steel pin	Light	M12	6	19.0	6
32840.W0012	Steel pin	Light	M12	6	26.5	8
32840.W0013	Steel pin	Standard	M12	6	11.5	5
32840.W0014	Steel pin	Standard	M12	6	19.0	7
32840.W0015	Steel pin	Standard	M12	6	26.5	10
32840.W0016	Steel pin	Heavy	M12	6	11.5	5
32840.W0017	Steel pin	Heavy	M12	6	19.0	8
32840.W0018	Steel pin	Heavy	M12	6	26.5	10
32840.W0019	Steel pin	Light	M18x1,5	10	18.0	19
32840.W0020	Steel pin	Light	M18x1,5	10	31.5	28
32840.W0021	Steel pin	Light	M18x1,5	10	45.0	36
32840.W0022	Steel pin	Standard	M18x1,5	10	18.0	20
32840.W0023	Steel pin	Standard	M18x1,5	10	31.5	29



Order No.	Pin material	Spring load	d ₁	d ₂	l ₁ -2	Weight g
32840.W0024	Steel pin	Standard	M18x1,5	10	45.0	39
32840.W0025	Steel pin	Heavy	M18x1,5	10	18.0	21
32840.W0026	Steel pin	Heavy	M18x1,5	10	31.5	30
32840.W0027	Steel pin	Heavy	M18x1,5	10	45.0	40
32840.W0401	Plastic pin	Light	M12	5	11.5	3
32840.W0402	Plastic pin	Light	M12	5	19.0	4
32840.W0403	Plastic pin	Light	M12	5	26.5	6
32840.W0410	Plastic pin	Light	M12	6	11.5	3
32840.W0411	Plastic pin	Light	M12	6	19.0	5
32840.W0412	Plastic pin	Light	M12	6	26.5	7
32840.W0419	Plastic pin	Light	M18x1,5	10	18.0	12
32840.W0420	Plastic pin	Light	M18x1,5	10	31.5	20
32840.W0421	Plastic pin	Light	M18x1,5	10	45.0	30

Order No.	l ₂	A/F	Spring colour	Spring pressure N	Stroke s	Temp. resistance °C max.	Fitting tool 32840
32840.W0001	6.4	10	S/S	20	1.6	250	.W0820
32840.W0002	6.4	10	S/S	20	1.6	250	.W0820
32840.W0003	6.4	10	S/S	20	1.6	250	.W0820
32840.W0004	6.4	10	Black	50	1.6	250	.W0820
32840.W0005	6.4	10	Black	50	1.6	250	.W0820
32840.W0006	6.4	10	Black	50	1.6	250	.W0820
32840.W0007	6.4	10	Blue	100	1.6	250	.W0820
32840.W0008	6.4	10	Blue	100	1.6	250	.W0820
32840.W0009	6.4	10	Blue	100	1.6	250	.W0820
32840.W0010	10.4	10	S/S	40	2.0	250	.W0820
32840.W0011	10.4	10	S/S	40	2.0	250	.W0820
32840.W0012	10.4	10	S/S	40	2.0	250	.W0820
32840.W0013	10.4	10	Black	75	2.0	250	.W0820
32840.W0014	10.4	10	Black	75	2.0	250	.W0820
32840.W0015	10.4	10	Black	75	2.0	250	.W0820
32840.W0016	10.4	10	Blue	100	2.0	250	.W0820
32840.W0017	10.4	10	Blue	100	2.0	250	.W0820
32840.W0018	10.4	10	Blue	100	2.0	250	.W0820
32840.W0019	16.9	16	S/S	100	3.2	250	.W0822
32840.W0020	16.9	16	S/S	100	3.2	250	.W0822
32840.W0021	16.9	16	S/S	100	3.2	250	.W0822
32840.W0022	16.9	16	Black	150	3.2	250	.W0822
32840.W0023	16.9	16	Black	150	3.2	250	.W0822
32840.W0024	16.9	16	Black	150	3.2	250	.W0822
32840.W0025	16.9	16	Blue	200	3.2	250	.W0822
32840.W0026	16.9	16	Blue	200	3.2	250	.W0822
32840.W0027	16.9	16	Blue	200	3.2	250	.W0822
32840.W0401	6.4	10	S/S	20	1.6	80	.W0820
32840.W0402	6.4	10	S/S	20	1.6	80	.W0820
32840.W0403	6.4	10	S/S	20	1.6	80	.W0820
32840.W0410	10.4	10	Black	40	2.0	80	.W0820
32840.W0411	10.4	10	Black	40	2.0	80	.W0820
32840.W0412	10.4	10	Black	40	2.0	80	.W0820
32840.W0419	16.9	16	Blue	100	3.2	80	.W0822
32840.W0420	16.9	16	Blue	100	3.2	80	.W0822
32840.W0421	16.9	16	Blue	100	3.2	80	.W0822



Side-Thrust Pins - Threaded without seal



Spring Plunger & Detent Pins





32850

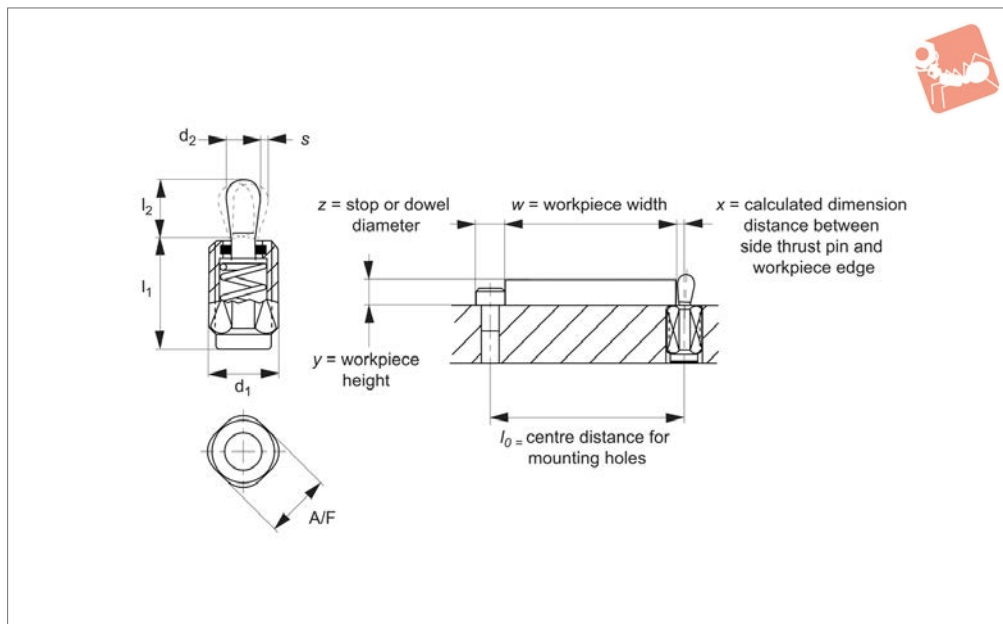

Material

Body: steel, zinc-plated by galvanization.
 Pin: steel, case hardened and galvanized, or thermoplastic (POM) white.
 Spring: steel (blackened or blue galvanized), or stainless steel.
 Seal: rubber (CR), 60 shore.

Technical Notes

Press fit installation into hole d_1 to tol. H8, using fitting tool (order separately).

Installation calculations;

A) Calculating centre distance for mounting holes (l_0);

$$l_0 = (z/2) + w + x$$

B) Calculating pin location (x);

When workpiece height (y) is greater than or equal to $l_2 - (d_2/2)$ then (x) is calculated as; $x = (d_2/2) - s$

When workpiece height (y) is less than $l_2 - (d_2/2)$ then (x) is calculated as; $x = (d_2/2) - s - \{ [l_2 - (d_2/2) - y] * 0.123 \}$

l_0 = centre distance for mounting holes
 y = workpiece height
 w = workpiece width
 x = distance between side-thrust pin and workpiece edge

s = stroke

z = stop or dowel stop diameter

Tips

Side-thrust pins are ideal for holding, clamping and positioning parts.

Spring colour gives visual indication of spring pressure (N).

Light spring load = natural stainless spring.

Standard spring load = steel spring, blackened.

Heavy spring load = steel spring, blue galvanized.

Order No.	Pin material	Spring load	d_1	d_2	$l_2 - \frac{d_2}{2}$	Weight g
32850.W0001	Steel pin	Light	M12	5	11.5	4
32850.W0002	Steel pin	Light	M12	5	19.0	6
32850.W0003	Steel pin	Light	M12	5	26.5	8
32850.W0004	Steel pin	Standard	M12	5	11.5	4
32850.W0005	Steel pin	Standard	M12	5	19.0	6
32850.W0006	Steel pin	Standard	M12	5	26.5	8
32850.W0007	Steel pin	Heavy	M12	5	11.5	4
32850.W0008	Steel pin	Heavy	M12	5	19.0	7
32850.W0009	Steel pin	Heavy	M12	5	26.5	9
32850.W0010	Steel pin	Light	M12	6	11.5	5
32850.W0011	Steel pin	Light	M12	6	19.0	6
32850.W0012	Steel pin	Light	M12	6	26.5	8
32850.W0013	Steel pin	Standard	M12	6	11.5	5
32850.W0014	Steel pin	Standard	M12	6	19.0	7
32850.W0015	Steel pin	Standard	M12	6	26.5	10
32850.W0016	Steel pin	Heavy	M12	6	11.5	5
32850.W0017	Steel pin	Heavy	M12	6	19.0	8
32850.W0018	Steel pin	Heavy	M12	6	26.5	10
32850.W0019	Steel pin	Light	M18x1,5	10	18.0	19
32850.W0020	Steel pin	Light	M18x1,5	10	31.5	28

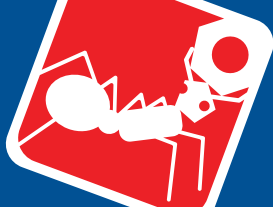

Side-Thrust Pins - Threaded with seal



Spring Plunger & Detent Pins

Order No.	Pin material	Spring load	d ₁	d ₂	l ₁₋₂	Weight g
32850.W0021	Steel pin	Light	M18x1,5	10	45.0	36
32850.W0022	Steel pin	Standard	M18x1,5	10	18.0	20
32850.W0023	Steel pin	Standard	M18x1,5	10	31.5	29
32850.W0024	Steel pin	Standard	M18x1,5	10	45.0	39
32850.W0025	Steel pin	Heavy	M18x1,5	10	18.0	21
32850.W0026	Steel pin	Heavy	M18x1,5	10	31.5	30
32850.W0027	Steel pin	Heavy	M18x1,5	10	45.0	40
32850.W0401	Plastic pin	Light	M12	5	11.5	3
32850.W0402	Plastic pin	Light	M12	5	19.0	4
32850.W0403	Plastic pin	Light	M12	5	26.5	6
32850.W0410	Plastic pin	Light	M12	6	11.5	3
32850.W0411	Plastic pin	Light	M12	6	19.0	5
32850.W0412	Plastic pin	Light	M12	6	26.5	7
32850.W0419	Plastic pin	Light	M18x1,5	10	18.0	12
32850.W0420	Plastic pin	Light	M18x1,5	10	31.5	20
32850.W0421	Plastic pin	Light	M18x1,5	10	45.0	30

Order No.	l ₂	A/F	Spring colour	Spring pressure N	Stroke s	Temp. resistance °C max.	Fitting tool 32840
32850.W0001	6	10	S/S	20	0.8	250	.W0820
32850.W0002	6	10	S/S	20	0.8	250	.W0820
32850.W0003	6	10	S/S	20	0.8	250	.W0820
32850.W0004	6	10	Black	50	0.8	250	.W0820
32850.W0005	6	10	Black	50	0.8	250	.W0820
32850.W0006	6	10	Black	50	0.8	250	.W0820
32850.W0007	6	10	Blue	100	0.8	250	.W0820
32850.W0008	6	10	Blue	100	0.8	250	.W0820
32850.W0009	6	10	Blue	100	0.8	250	.W0820
32850.W0010	10	10	S/S	40	1.0	250	.W0820
32850.W0011	10	10	S/S	40	1.0	250	.W0820
32850.W0012	10	10	S/S	40	1.0	250	.W0820
32850.W0013	10	10	Black	75	1.0	250	.W0820
32850.W0014	10	10	Black	75	1.0	250	.W0820
32850.W0015	10	10	Black	75	1.0	250	.W0820
32850.W0016	10	10	Blue	100	1.0	250	.W0820
32850.W0017	10	10	Blue	100	1.0	250	.W0820
32850.W0018	10	10	Blue	100	1.0	250	.W0820
32850.W0019	16	16	S/S	100	1.6	250	.W0822
32850.W0020	16	16	S/S	100	1.6	250	.W0822
32850.W0021	16	16	S/S	100	1.6	250	.W0822
32850.W0022	16	16	Black	150	1.6	250	.W0822
32850.W0023	16	16	Black	150	1.6	250	.W0822
32850.W0024	16	16	Black	150	1.6	250	.W0822
32850.W0025	16	16	Blue	200	1.6	250	.W0822
32850.W0026	16	16	Blue	200	1.6	250	.W0822
32850.W0027	16	16	Blue	200	1.6	250	.W0822
32850.W0401	6	10	S/S	20	0.8	80	.W0820
32850.W0402	6	10	S/S	20	0.8	80	.W0820
32850.W0403	6	10	S/S	20	0.8	80	.W0820
32850.W0410	10	10	Black	40	1.0	80	.W0820
32850.W0411	10	10	Black	40	1.0	80	.W0820
32850.W0412	10	10	Black	40	1.0	80	.W0820
32850.W0419	16	16	Blue	100	1.6	80	.W0822
32850.W0420	16	16	Blue	100	1.6	80	.W0822
32850.W0421	16	16	Blue	100	1.6	80	.W0822

SPRING PLUNGER & DETENT PINS

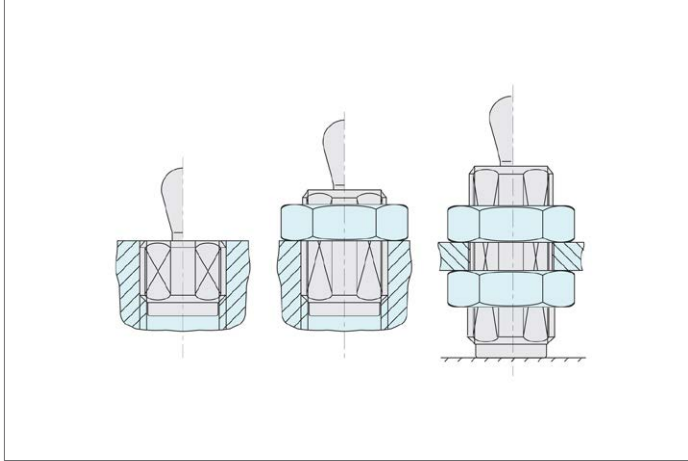



Side-Thrust Pins - Threaded

without seal - for use with pins of your own design

Spring Plunger & Detent Pins

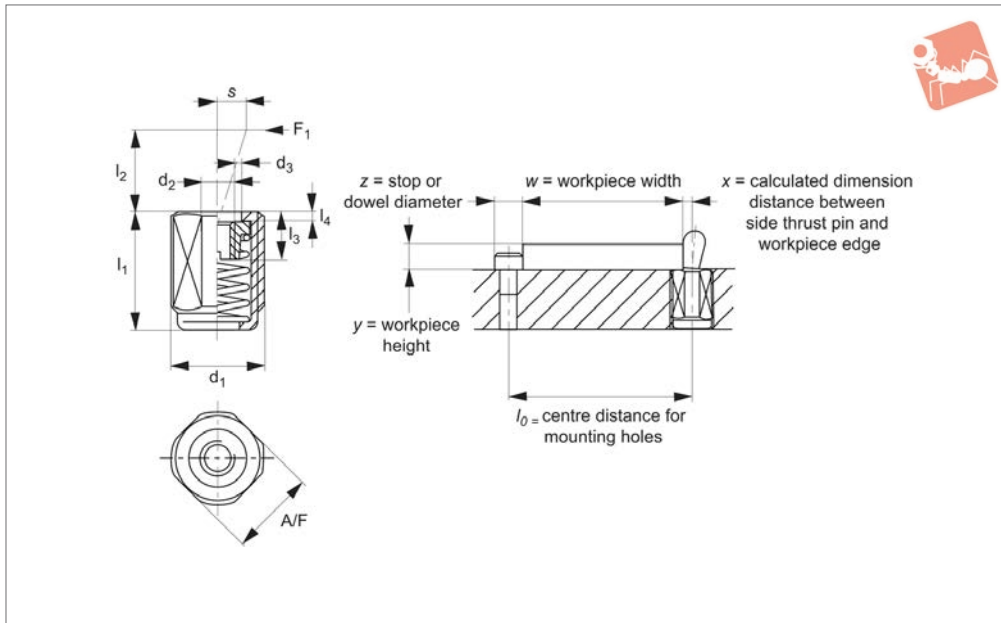

32860.1

SPRING PLUNGER & DETENT PINS

Material

Body: aluminium.
Threaded washer: steel, blackened.
Spring: steel (blackened or blue galvanized), or stainless steel.

Technical Notes

Press fit installation into hole d_1 to tol. H8, using fitting tool (order separately).

Installation calculations;

A) Calculating centre distance for mounting holes (l_0);

$$l_0 = (z/2) + w + x$$

B) Calculating pin location (x);

When workpiece height (y) is greater than or equal to $l_2 - (d_2/2)$ then (x) is calculated as; $x = (d_2/2) - s$

When workpiece height (y) is less than $l_2 - (d_2/2)$ then (x) is calculated as; $x = (d_2/2) - s - \{[l_2 - (d_2/2) - y] * 0.123\}$

l_0 = centre distance for mounting holes

y = workpiece height

w = workpiece width

x = distance between side-thrust pin and workpiece edge

s = stroke

z = stop or dowel stop diameter

Tips

Side-thrust pins are ideal for holding, clamping and positioning parts.

Spring colour gives visual indication of spring pressure (N).

Light spring load = natural stainless spring.

Standard spring load = steel spring, blackened.

Heavy spring load = steel spring, blue galvanized.

Order No.	Spring load	d_1	d_2	d_3	l_{-2}	l_2	Weight g
32860.W0001	Light	M12	M4	6.1	11.5	4.0	3
32860.W0002	Light	M12	M4	6.1	19.0	4.0	5
32860.W0003	Light	M12	M4	6.1	26.5	4.0	7
32860.W0004	Standard	M12	M4	6.1	11.5	4.0	3
32860.W0005	Standard	M12	M4	6.1	19.0	4.0	6
32860.W0006	Standard	M12	M4	6.1	26.5	4.0	8
32860.W0007	Heavy	M12	M4	6.1	11.5	4.0	4
32860.W0008	Heavy	M12	M4	6.1	19.0	4.0	6
32860.W0009	Heavy	M12	M4	6.1	26.5	4.0	8
32860.W0010	Light	M12	M4	6.1	11.5	7.5	3
32860.W0011	Light	M12	M4	6.1	19.0	7.5	5
32860.W0012	Light	M12	M4	6.1	26.5	7.5	7
32860.W0013	Standard	M12	M4	6.1	11.5	7.5	3
32860.W0014	Standard	M12	M4	6.1	19.0	7.5	6
32860.W0015	Standard	M12	M4	6.1	26.5	7.5	8
32860.W0016	Heavy	M12	M4	6.1	11.5	7.5	4
32860.W0017	Heavy	M12	M4	6.1	19.0	7.5	6
32860.W0018	Heavy	M12	M4	6.1	26.5	7.5	9
32860.W0019	Light	M18x1,5	M6	10.1	18.0	11.5	15
32860.W0020	Light	M18x1,5	M6	10.1	31.5	11.5	23
32860.W0021	Light	M18x1,5	M6	10.1	45.0	11.5	32
32860.W0022	Standard	M18x1,5	M6	10.1	18.0	11.5	14



Order No.	Spring load	d ₁	d ₂	d ₃	l ₁ -2	l ₂	Weight g
32860.W0023	Standard	M18x1,5	M6	10.1	31.5	11.5	23
32860.W0024	Standard	M18x1,5	M6	10.1	45.0	11.5	32
32860.W0025	Heavy	M18x1,5	M6	10.1	18.0	11.5	14
32860.W0026	Heavy	M18x1,5	M6	10.1	31.5	11.5	23
32860.W0027	Heavy	M18x1,5	M6	10.1	45.0	11.5	32

Order No.	l ₃	l ₄	A/F	Spring colour	Spring pressure N	Stroke s	Temp. resistance °C max.	Fitting tool 32840
32860.W0001	4.5	1.5	10	S/S	20	1.6	250	.W0820
32860.W0002	4.5	1.5	10	S/S	20	1.6	250	.W0820
32860.W0003	4.5	1.5	10	S/S	20	1.6	250	.W0820
32860.W0004	4.5	1.5	10	Black	50	1.6	250	.W0820
32860.W0005	4.5	1.5	10	Black	50	1.6	250	.W0820
32860.W0006	4.5	1.5	10	Black	50	1.6	250	.W0820
32860.W0007	4.5	1.5	10	Blue	100	1.6	250	.W0820
32860.W0008	4.5	1.5	10	Blue	100	1.6	250	.W0820
32860.W0009	4.5	1.5	10	Blue	100	1.6	250	.W0820
32860.W0010	4.5	1.5	10	S/S	40	2.0	250	.W0820
32860.W0011	4.5	1.5	10	S/S	40	2.0	250	.W0820
32860.W0012	4.5	1.5	10	S/S	40	2.0	250	.W0820
32860.W0013	4.5	1.5	10	Black	75	2.0	250	.W0820
32860.W0014	4.5	1.5	10	Black	75	2.0	250	.W0820
32860.W0015	4.5	1.5	10	Black	75	2.0	250	.W0820
32860.W0016	4.5	1.5	10	Blue	100	2.0	250	.W0820
32860.W0017	4.5	1.5	10	Blue	100	2.0	250	.W0820
32860.W0018	4.5	1.5	10	Blue	100	2.0	250	.W0820
32860.W0019	7.5	1.5	16	S/S	100	3.2	250	.W0822
32860.W0020	7.5	1.5	16	S/S	100	3.2	250	.W0822
32860.W0021	7.5	1.5	16	S/S	100	3.2	250	.W0822
32860.W0022	7.5	1.5	16	Black	150	3.2	250	.W0822
32860.W0023	7.5	1.5	16	Black	150	3.2	250	.W0822
32860.W0024	7.5	1.5	16	Black	150	3.2	250	.W0822
32860.W0025	7.5	1.5	16	Blue	200	3.2	250	.W0822
32860.W0026	7.5	1.5	16	Blue	200	3.2	250	.W0822
32860.W0027	7.5	1.5	16	Blue	200	3.2	250	.W0822



Side-Thrust Pins - Threaded with seal - for use with pins of your own design

Spring Plunger & Detent Pins

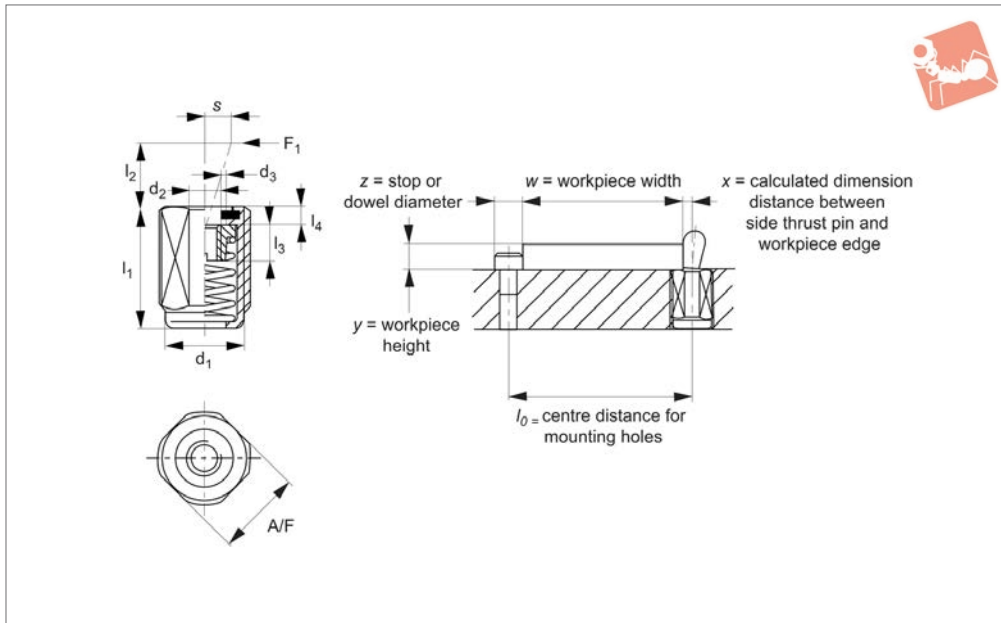

32860.2

SPRING PLUNGER & DETENT PINS

Material

Body: aluminium.
Threaded washer: steel, blackened
Spring: steel (blackened or blue galvanized), or stainless steel.
Seal: rubber (CR), 60 shore.

Technical Notes

Press fit installation into hole d_1 to tol. H8, using fitting tool (order separately).

Installation calculations;

A) Calculating centre distance for mounting holes (l_0);

$$l_0 = (z/2) + w + x$$

B) Calculating pin location (x);

When workpiece height (y) is greater than or equal to $l_2 - (d_2/2)$ then (x) is calculated as; $x = (d_2/2) - s$

When workpiece height (y) is less than $l_2 - (d_2/2)$ then (x) is calculated as; $x = (d_2/2) - s - \{[l_2 - (d_2/2) - y] * 0.123\}$

l_0 = centre distance for mounting holes

y = workpiece height

w = workpiece width

x = distance between side-thrust pin and

workpiece edge

s = stroke

z = stop or dowel stop diameter

Tips

Side-thrust pins are ideal for holding, clamping and positioning parts.

Spring colour gives visual indication of spring pressure (N).

Light spring load = natural stainless spring.

Standard spring load = steel spring, blackened.

Heavy spring load = steel spring, blue galvanized.

Order No.	Spring load	d_1	d_2	d_3	l_{-2}	l_2	Weight g
32860.W0401	Light	M12	M4	6.1	11.5	4.0	3
32860.W0402	Light	M12	M4	6.1	19.0	4.0	5
32860.W0403	Light	M12	M4	6.1	26.5	4.0	7
32860.W0404	Standard	M12	M4	6.1	11.5	4.0	3
32860.W0405	Standard	M12	M4	6.1	19.0	4.0	6
32860.W0406	Standard	M12	M4	6.1	26.5	4.0	8
32860.W0407	Heavy	M12	M4	6.1	11.5	4.0	4
32860.W0408	Heavy	M12	M4	6.1	19.0	4.0	6
32860.W0409	Heavy	M12	M4	6.1	26.5	4.0	8
32860.W0410	Light	M12	M4	6.1	11.5	7.5	3
32860.W0411	Light	M12	M4	6.1	19.0	7.5	5
32860.W0412	Light	M12	M4	6.1	26.5	7.5	7
32860.W0413	Standard	M12	M4	6.1	11.5	7.5	3
32860.W0414	Standard	M12	M4	6.1	19.0	7.5	6
32860.W0415	Standard	M12	M4	6.1	26.5	7.5	8
32860.W0416	Heavy	M12	M4	6.1	11.5	7.5	4
32860.W0417	Heavy	M12	M4	6.1	19.0	7.5	6
32860.W0418	Heavy	M12	M4	6.1	26.5	7.5	9
32860.W0419	Light	M18x1,5	M6	10.1	18.0	11.5	15
32860.W0420	Light	M18x1,5	M6	10.1	31.5	11.5	23
32860.W0421	Light	M18x1,5	M6	10.1	45.0	11.5	32
32860.W0422	Standard	M18x1,5	M6	10.1	18.0	11.5	14



Order No.	Spring load	d ₁	d ₂	d ₃	l ₁₋₂	l ₂	Weight g
32860.W0423	Standard	M18x1,5	M6	10.1	31.5	11.5	23
32860.W0424	Standard	M18x1,5	M6	10.1	45.0	11.5	32
32860.W0425	Heavy	M18x1,5	M6	10.1	18.0	11.5	14
32860.W0426	Heavy	M18x1,5	M6	10.1	31.5	11.5	23
32860.W0427	Heavy	M18x1,5	M6	10.1	45.0	11.5	32

Order No.	l ₃	l ₄	A/F	Spring colour	Spring pressure N	Stroke s	Temp. resistance °C max.	Fitting tool 32840
32860.W0401	4.5	2.0	10	S/S	20	1.6	110	.W0820
32860.W0402	4.5	2.0	10	S/S	20	1.6	110	.W0820
32860.W0403	4.5	2.0	10	S/S	20	1.6	110	.W0820
32860.W0404	4.5	2.0	10	Black	50	1.6	110	.W0820
32860.W0405	4.5	2.0	10	Black	50	1.6	110	.W0820
32860.W0406	4.5	2.0	10	Black	50	1.6	110	.W0820
32860.W0407	4.5	2.0	10	Blue	100	1.6	110	.W0820
32860.W0408	4.5	2.0	10	Blue	100	1.6	110	.W0820
32860.W0409	4.5	2.0	10	Blue	100	1.6	110	.W0820
32860.W0410	4.5	2.0	10	S/S	40	2.0	110	.W0820
32860.W0411	4.5	2.0	10	S/S	40	2.0	110	.W0820
32860.W0412	4.5	2.0	10	S/S	40	2.0	110	.W0820
32860.W0413	4.5	2.0	10	Black	75	2.0	110	.W0820
32860.W0414	4.5	2.0	10	Black	75	2.0	110	.W0820
32860.W0415	4.5	2.0	10	Black	75	2.0	110	.W0820
32860.W0416	4.5	2.0	10	Blue	100	2.0	110	.W0820
32860.W0417	4.5	2.0	10	Blue	100	2.0	110	.W0820
32860.W0418	4.5	2.0	10	Blue	100	2.0	110	.W0820
32860.W0419	7.5	2.3	16	S/S	100	3.2	110	.W0822
32860.W0420	7.5	2.3	16	S/S	100	3.2	110	.W0822
32860.W0421	7.5	2.3	16	S/S	100	3.2	110	.W0822
32860.W0422	7.5	2.3	16	Black	150	3.2	110	.W0822
32860.W0423	7.5	2.3	16	Black	150	3.2	110	.W0822
32860.W0424	7.5	2.3	16	Black	150	3.2	110	.W0822
32860.W0425	7.5	2.3	16	Blue	200	3.2	110	.W0822
32860.W0426	7.5	2.3	16	Blue	200	3.2	110	.W0822
32860.W0427	7.5	2.3	16	Blue	200	3.2	110	.W0822



Side-Thrust Pins with plastic spring

Spring Plunger & Detent Pins

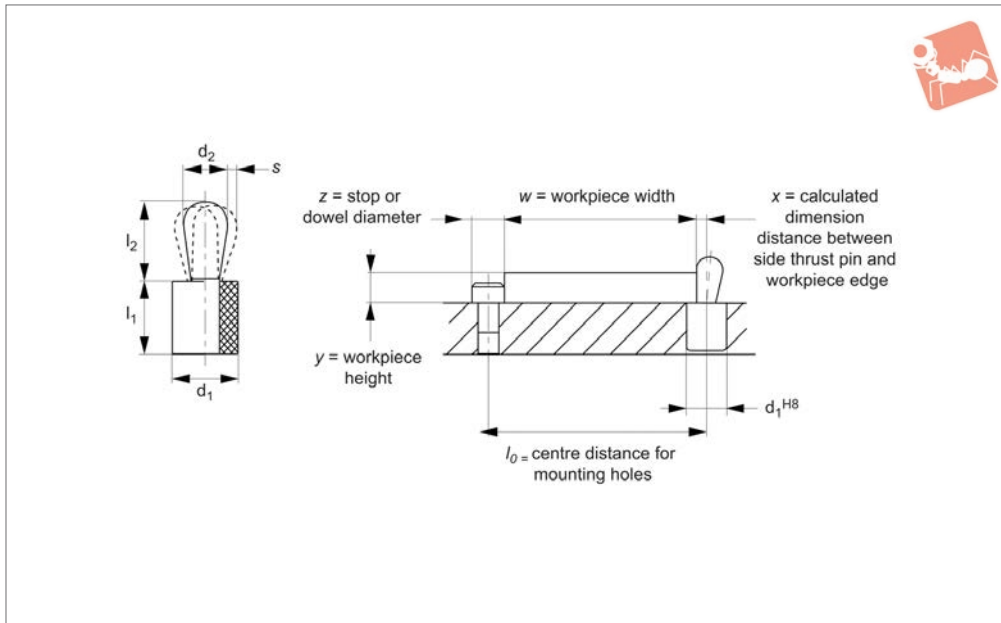

32870

SPRING PLUNGER & DETENT PINS

Material

Spring Body: plastic.

Pin: steel, case hardened and galvanized, stainless steel or thermoplastic (POM) white.

Technical Notes

Press fit installation into hole d_1 to tol. H8, using fitting tool (order separately).

Installation calculations;

A) Calculating centre distance for mounting holes (l_0);

$$l_0 = (z/2) + w + x$$

B) Calculating pin location (x);

When workpiece height (y) is greater than or equal to $l_2 - (d_2/2)$ then (x) is calculated as; $x = (d_2/2) - s$

When workpiece height (y) is less than $l_2 - (d_2/2)$ then (x) is calculated as; $x = (d_2/2) - s - \{ [l_2 - (d_2/2) - y] * 0.123 \}$

l_0 = centre distance for mounting holes

y = workpiece height

w = workpiece width

x = distance between side-thrust pin and workpiece edge

s = stroke

z = stop or dowel stop diameter

Tips

Side-thrust pins are ideal for holding, clamping and positioning parts.

Spring colour gives visual indication of spring pressure (N).

Light spring load = blue plastic.

Standard spring load = red plastic.

Heavy spring load = green plastic.

Order No.	Pin material	Spring load	d_1	d_2	l_{-1}	Weight g
32870.W0001	Steel Pin	Light	6	3	7	1
32870.W0002	Steel Pin	Standard	6	3	7	1
32870.W0003	Steel Pin	Light	8	4	9	1
32870.W0004	Steel Pin	Standard	8	4	9	1
32870.W0005	Steel Pin	Light	10	5	9	2
32870.W0006	Steel Pin	Standard	10	5	9	2
32870.W0007	Steel Pin	Heavy	10	5	9	2
32870.W0008	Steel Pin	Light	10	6	9	3
32870.W0009	Steel Pin	Standard	10	6	9	3
32870.W0010	Steel Pin	Heavy	10	6	9	3
32870.W0012	Steel Pin	Standard	12	8	13	7
32870.W0013	Steel Pin	Heavy	12	8	13	7
32870.W0014	Steel Pin	Standard	16	10	16	15
32870.W0015	Steel Pin	Heavy	16	10	16	15
32870.W0401	Plastic Pin	Light	6	3	7	1
32870.W0402	Plastic Pin	Standard	6	3	7	1
32870.W0403	Plastic Pin	Light	8	4	9	1
32870.W0404	Plastic Pin	Standard	8	4	9	1
32870.W0405	Plastic Pin	Light	10	5	9	2
32870.W0406	Plastic Pin	Standard	10	5	9	2
32870.W0407	Plastic Pin	Heavy	10	5	9	2
32870.W0408	Plastic Pin	Light	10	6	9	3
32870.W0409	Plastic Pin	Standard	10	6	9	3



Order No.	Pin material	Spring load	d ₁	d ₂	l ₁ -i	Weight g
32870.W0410	Plastic Pin	Heavy	10	6	9	3
32870.W0412	Plastic Pin	Standard	12	8	13	7
32870.W0413	Plastic Pin	Heavy	12	8	13	7
32870.W0414	Plastic Pin	Standard	16	10	16	15
32870.W0415	Plastic Pin	Heavy	16	10	16	15
32870.W0601	Stainless Pin	Light	6	3	7	1
32870.W0602	Stainless Pin	Standard	6	3	7	1
32870.W0603	Stainless Pin	Light	8	4	9	1
32870.W0604	Stainless Pin	Standard	8	4	9	1
32870.W0605	Stainless Pin	Light	10	5	9	2
32870.W0606	Stainless Pin	Standard	10	5	9	2
32870.W0607	Stainless Pin	Heavy	10	5	9	2
32870.W0608	Stainless Pin	Light	10	6	9	3
32870.W0609	Stainless Pin	Standard	10	6	9	3
32870.W0610	Stainless Pin	Heavy	10	6	9	3
32870.W0612	Stainless Pin	Standard	12	8	13	7
32870.W0613	Stainless Pin	Heavy	12	8	13	7
32870.W0614	Stainless Pin	Standard	16	10	16	15
32870.W0615	Stainless Pin	Heavy	16	10	16	15
32870.W0840	Fitting Tool	-	-	-	-	23
32870.W0841	Fitting Tool	-	-	-	-	47
32870.W0842	Fitting Tool	-	-	-	-	46
32870.W0843	Fitting Tool	-	-	-	-	98
32870.W0844	Fitting Tool	-	-	-	-	145

Order No.	l ₂ ±0.5	Location hole d ₁ tol. H8	Spring colour	Spring pressure N	Stroke s	Temp. resistance °C max.	Fitting tool 32870
32870.W0001	3.7	5.9	Blue	10	0.4	100	.W0840
32870.W0002	3.7	5.9	Red	20	0.4	100	.W0840
32870.W0003	5.2	7.9	Blue	15	0.6	100	.W0841
32870.W0004	5.2	7.9	Red	30	0.6	100	.W0841
32870.W0005	7.3	9.9	Blue	30	0.8	100	.W0842
32870.W0006	7.3	9.9	Red	60	0.8	100	.W0842
32870.W0007	7.3	9.9	Green	90	0.8	100	.W0842
32870.W0008	10.3	9.9	Blue	20	1.0	100	.W0842
32870.W0009	10.3	9.9	Red	30	1.0	100	.W0842
32870.W0010	10.3	9.9	Green	60	1.0	100	.W0842
32870.W0012	13.3	11.6	Red	50	1.2	100	.W0843
32870.W0013	13.3	11.9	Green	100	1.2	100	.W0843
32870.W0014	16.9	15.9	Red	60	1.6	100	.W0844
32870.W0015	16.9	15.9	Green	160	1.6	100	.W0844
32870.W0401	3.7	5.9	Blue	10	0.4	100	.W0840
32870.W0402	3.7	5.9	Red	20	0.4	100	.W0840
32870.W0403	5.2	7.9	Blue	15	0.6	100	.W0841
32870.W0404	5.2	7.9	Red	30	0.6	100	.W0841
32870.W0405	7.3	9.9	Blue	30	0.8	100	.W0842
32870.W0406	7.3	9.9	Red	60	0.8	100	.W0842
32870.W0407	7.3	9.9	Green	90	0.8	100	.W0842
32870.W0408	10.3	9.9	Blue	20	1.0	100	.W0842
32870.W0409	10.3	9.9	Red	30	1.0	100	.W0842
32870.W0410	10.3	9.9	Green	60	1.0	100	.W0842
32870.W0412	13.3	11.6	Red	50	1.2	100	.W0843
32870.W0413	13.3	11.9	Green	100	1.2	100	.W0843
32870.W0414	16.9	15.9	Red	60	1.6	100	.W0844
32870.W0415	16.9	15.9	Green	160	1.6	100	.W0844
32870.W0601	3.7	5.9	Blue	10	0.4	100	.W0840
32870.W0602	3.7	5.9	Red	20	0.4	100	.W0840
32870.W0603	5.2	7.9	Blue	15	0.6	100	.W0841
32870.W0604	5.2	7.9	Red	30	0.6	100	.W0841
32870.W0605	7.3	9.9	Blue	30	0.8	100	.W0842
32870.W0606	7.3	9.9	Red	60	0.8	100	.W0842
32870.W0607	7.3	9.9	Green	90	0.8	100	.W0842
32870.W0608	10.3	9.9	Blue	20	1.0	100	.W0842
32870.W0609	10.3	9.9	Red	30	1.0	100	.W0842
32870.W0610	10.3	9.9	Green	60	1.0	100	.W0842
32870.W0612	13.3	11.6	Red	50	1.2	100	.W0843
32870.W0613	13.3	11.9	Green	100	1.2	100	.W0843



Side-Thrust Pins with plastic spring



Spring Plunger & Detent Pins

Order No.	l_2 ± 0.5	Location hole d_1 tol. H8	Spring colour	Spring pressure N	Stroke s	Temp. resistance $^{\circ}\text{C}$ max.	Fitting tool 32870
32870.W0614	16.9	15.9	Red	60	1.6	100	.W0844
32870.W0615	16.9	15.9	Green	160	1.6	100	.W0844
32870.W0840	-	-	-	-	-	-	-
32870.W0841	-	-	-	-	-	-	-
32870.W0842	-	-	-	-	-	-	-
32870.W0843	-	-	-	-	-	-	-
32870.W0844	-	-	-	-	-	-	-

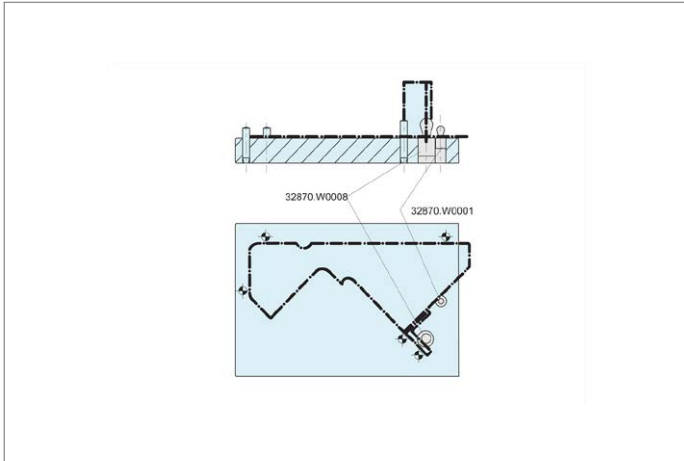



32802

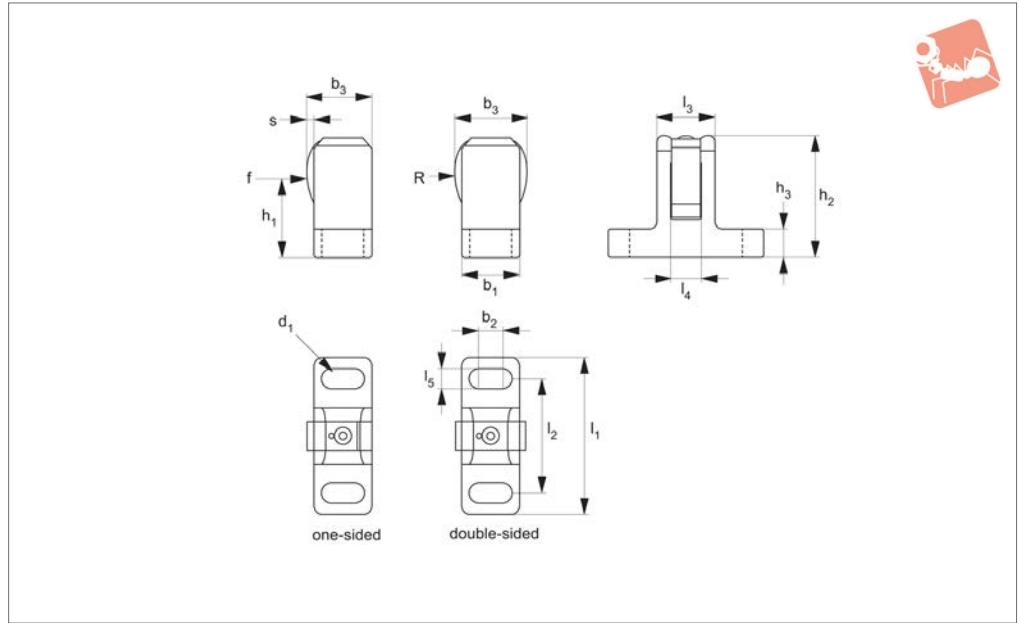

Material

Body: steel, blackened.
Spring element: stainless steel.

Technical Notes

Simple and secure positioning of work

pieces or components. If component is mounted below height h_1 , a down hold clamping effect is present. Double sided version, ideal for multi-component clamping.

Max. temperature resistance 250°C

Order No.	Finish	d_1 for screw	h_1	$h_2 \pm 1$	h_3	$l_1 \pm 1$	l_2	l_3	l_4	Weight g
32802.W0006	One-Sided	M 6	28.5	43.0	10	55	40	20	10	130
32802.W0012	One-Sided	M12	40.5	61.5	15	72	50	23	12	255
32802.W0206	Double-Sided	M 6	28.5	42.5	10	55	40	20	10	135
32802.W0212	Double-Sided	M12	40.5	61.5	15	72	50	23	12	260

Order No.	l_5	$b_1 \pm 0.5$	b_2	b_3	s	Spring load F N ~	R
32802.W0006	6.6	20	8	22.5	1.5	55	22.5
32802.W0012	13.5	25	6	29.0	1.5	170	32.8
32802.W0206	6.6	20	8	25.0	1.5	55	22.5
32802.W0212	13.5	25	6	33.5	1.5	170	32.8



A Wide Selection of Solutions

- Locating and positioning.
- Indexing.
- Securing.
- Positive locking.
- Rapid adjustment of all kinds of tables, platforms and fixtures.
- Machine and fixture design.
- OEM products.
- Sports equipment.
- Medical aides (wheelchairs etc.).
- Aerospace.
- Machine cabinets.

Applications

Materials

Locking or Non Locking

Handling and Actuation Methods

Mounting Options

Additional Technical Notes

Spring Loads



Steel with plastic grip



Stainless with plastic grip



Stainless body and grip



Locking (park)



Non locking (spring back)



Push pull



Standard grip



Lever grip



T-handle



Pull ring



Threaded for bespoke handle



Fine threaded (standard)



Coarse thread



Flange mount



Thin wall mount



Weldable

- Unless otherwise stated, grips on index plungers are not removable.
- Many of the pins on index plungers are toleranced to either the pin or the hole. Please refer to the specific product table.
- Index plungers are not recommended for shear load applications.

	Pin Tol.	Hole Tol.
①	h_9	+0,03 +0,08
②	-0,02 -0,04	H_7

s Stroke, or movement of plunger's pin.

f₁ The force required in Newtons (N) to overcome the static strength of the spring and achieve initial movement of the plunger's pin.

f₂ The force required in Newtons (N) to fully compress the spring until the pin is fully depressed against the plunger's body.

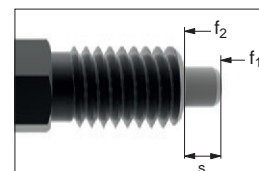



Wixroyd side-thrust pins are an economical way to clamp, hold and position components – from low height PCB's to relatively large castings.



Easy to Use

Simple to mount, easy to use and space saving.

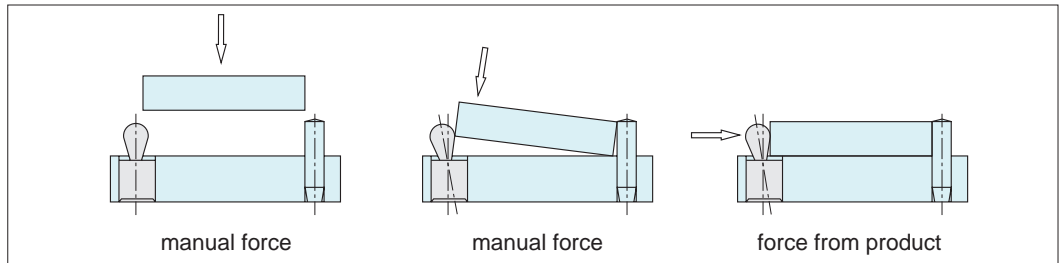

- Easy handling.
- Minimum mounting space.
- Simple and rapid changeover.
- Ideal for flat pieces.
- Reduced clamping times.
- Constant clamping pressure.

Installation Calculations of Side Thrust Pins

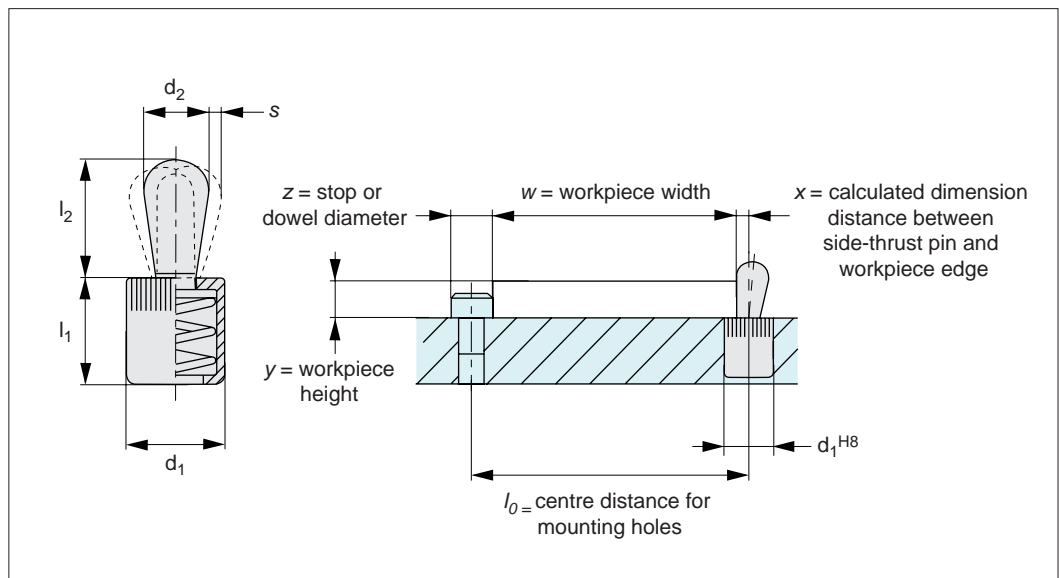

A) Calculating centre distance for mounting holes (l_0);

$$l_0 = (z/2) + w + x$$

B) Calculating pin location (x);

When workpiece height (y) is greater than or equal to $l_2 - (d_2/2)$ then (x) is calculated as;

$$x = (d_2/2) - s$$

When workpiece height (y) is less than $l_2 - (d_2/2)$ then (x) is calculated as;

$$x = (d_2/2) - s - \{ [l_2 - (d_2/2) - y] * 0.123 \}$$

l_0 = centre distance for mounting holes

y = workpiece height

w = workpiece width

x = distance between side-thrust pin and workpiece edge

s = stroke

z = stop or dowel stop diameter



Wixroyd Side-Thrust Pins

factors to consider in pin selection

32810 - 32870

Positioning Elements

The best selection of side thrust pins is made with consideration to the following four factors:

- a) Pin size Ø
- b) Pin material
- c) Sealed or non-sealed pin
- d) Required pin force

Pin size Ø	Application
3 mm	Circuit boards, thin metals
4 mm	Electronics, measuring equipment, small precise parts
5 mm	Drilling jigs, sheet metal, measuring devices, welding fixtures
6 mm	Fixtures for light machine parts and castings
8 mm	Fixtures for medium machine parts and castings
10 mm	Fixtures for heavy machine parts and castings

Pin Size Ø

Plastic pins for sensitive parts. Steel pins for other parts. Stainless steel pins in corrosive environments.

Pin Material

With/without seal	Application	Operation
Use side-thrust pins with seal e.g. 32820, 32850 etc	Milling, drilling, reaming, broaching, honing, engraving	Machining
	Washing, polishing, painting, sand blasting	After machining
Use side-thrust pins without seal e.g. 32810, 32840 etc	Gluing, welding, hard soldering	Prior to machining
	Gripping, inserting, fitting	Final mounting
	Measuring, controlling, loading	Quality assurance
	Soft soldering, checking	Processing circuit boards

Sealed or Non-sealed Pin

Positioning applications 30 - 60 N. Clamping applications 90 - 150 N.

Pinforce - Guide Only

Available in an aluminium body, and in various spring pressures from 10 to 300N. Each pin size is usually available in 3 spring pressures.

Pressure	Low	Medium	High
Spring Colour	Stainless	Black	Blue

Compression Spring Type

Available in elastomer body and in various spring pressures from 10 to 160N.

Elastomer Spring Type

Side-thrust pins find applications in the following industries and more:

- Automotive.
- Aviation.
- Electronics.
- Computing.
- Plastics.
- Medical.
- Precision engineering.
- Tool manufacturing.

Typical Applications

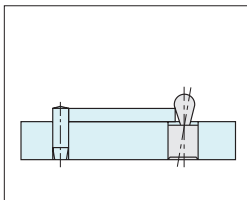

Positioning and clamping even extremely flat parts (e.g. metal sheets and printed circuit boards).

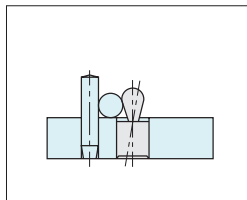

Positioning and clamping round metal using the deep drawing effect.

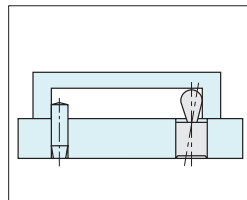

Space saving positioning and clamping from the inside to the outside.

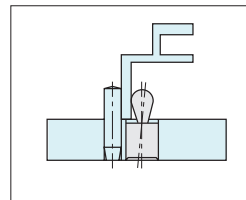

Positioning and clamping different profiles when welding. Material expansions compensated for by flexibility of the side-thrust pin.

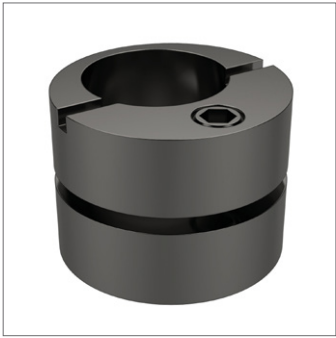

32900

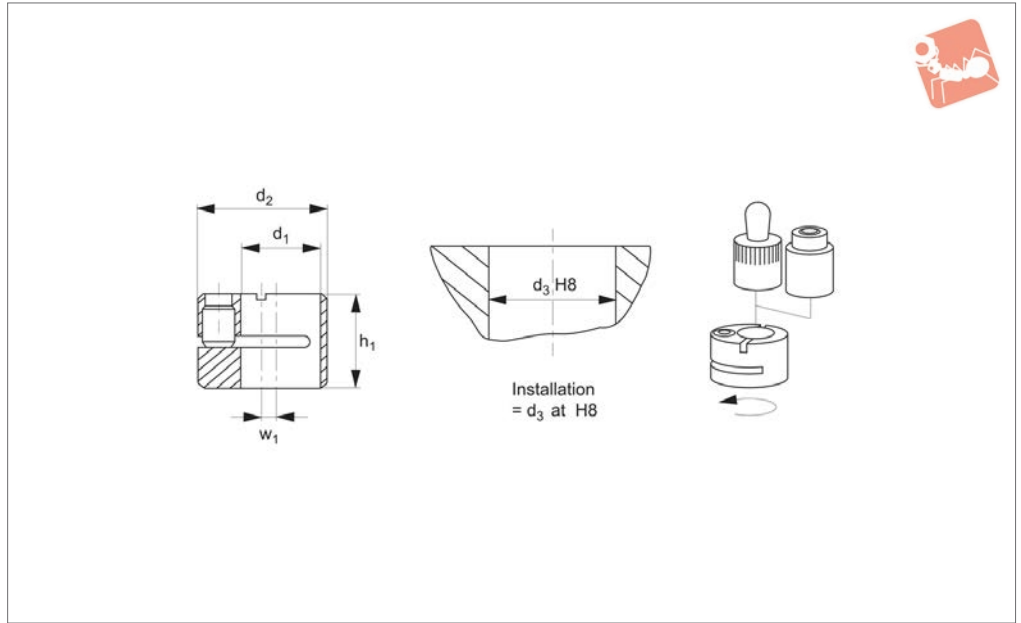

Material

Steel, blackend.

side-thrust pins nos. 32810, 32820 and side-thrust roller bearing no. 32880 when workpieces have large tolerances.

Technical Notes

The eccentric bushings are used to position

Order No.	d_1 tol. H8	d_2 tol. h9	d_3 tol. H8	w_1	h_1	Weight g
32900.W0001	6	12	12	2	9.9	6
32900.W0003	10	16	16	2	11.9	10
32900.W0004	12	18	18	2	13.9	13
32900.W0005	16	25	25	3	17.9	35

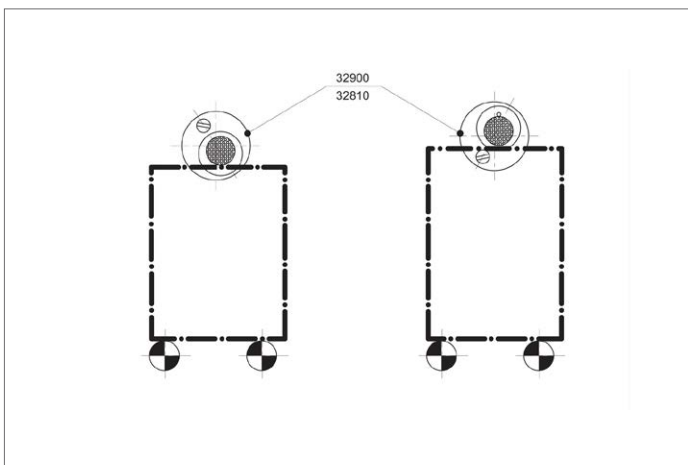

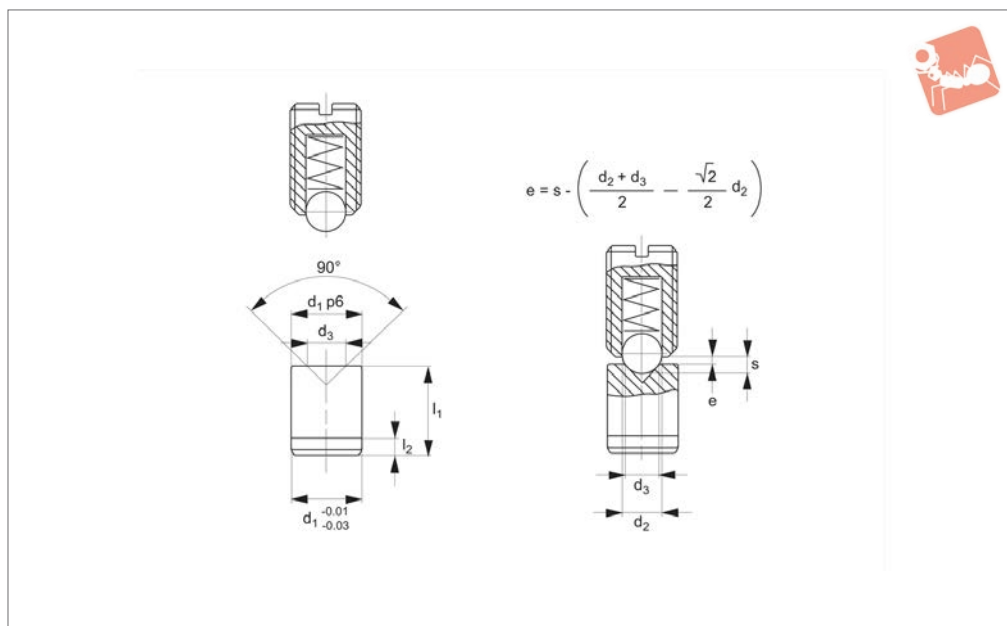

32440

SPRING PLUNGER & DETENT PINS

Material

Burnished, ground, hardened steel.

Technical Notes

Striker bushings are used together with spring plungers when a contact surface is required with high resistance. In particular

they are recommended for use with spring plungers equipped with high load value and those with increased spring loads.

Tips

For dimensions d2 and s, please see corresponding spring plunger. Striker bushes

are for use with Wixroyd nos. 31500, 32100, 32150, 32200 & 32300 see stated ,e' values for each type.

Order No.	d ₁ tol. p6	d ₂ & s		d ₃	l ₁ ±0.05	Weight g
32440.W0004	4	See corresponding plunger table		1.5	5	1
32440.W0005	5	See corresponding plunger table		2.0	6	1
32440.W0006	6	See corresponding plunger table		2.0	8	2
32440.W0008	8	See corresponding plunger table		3.0	10	4
32440.W0010	10	See corresponding plunger table		4.0	12	7
32440.W0012	12	See corresponding plunger table		6.0	14	12
32440.W0016	16	See corresponding plunger table		8.0	18	26

Order No.	l ₂	For 32100 e =	For 32150 e =	For 32200 e =	For 32300 e =
32440.W0004	2	M_4 = 0,6	M_4 = 1,1	M_4 = 1,1	-
32440.W0005	2	M_5 = 0,4	M_5 = 1,5	M_5 = 1,8	Ø 4 mm = 0,4
32440.W0006	2	M_6 = 0,6	M_6 = 1,6	M_6 = 2,1	Ø 5 mm = 0,8
32440.W0008	2	M_8 = 0,9	M_8 = 1,3	M_8 = 2,2	Ø 6 mm = 1,1
32440.W0010	3	M10 = 1,2	M10 = 1,4	M10 = 1,8	Ø 8 mm = 1,2
32440.W0012	3	M12 = 1,2	M12 = 1,7	M12 = 2,2	Ø 10 mm = 1,9
32440.W0016	3	M16 = 1,6	M16 = 2,3	M16 = 2,5	Ø 12 mm = 1,9

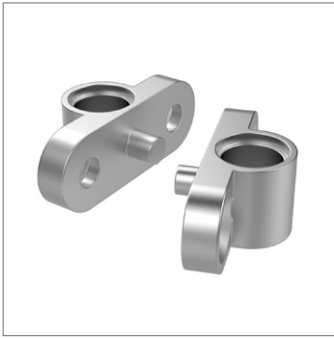

32450

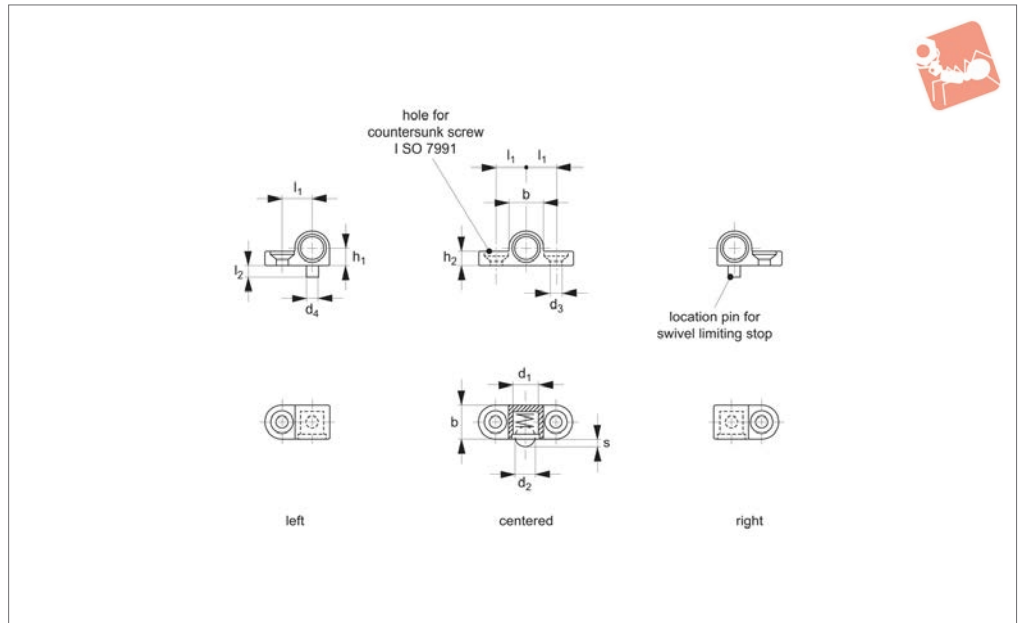

Material

Die-cast zinc, nickel plated.

available.

32300#26>, their small dimensions make them ideal for confined spaces.

Technical Notes

Left, right and centre mounting options

Tips

Assist in the easy mounting of smooth bodied spring plunger 32300<X\

Order No.	Type	Ball dia. plunger 32300 d_2	Body dia. plunger 32300 d_1 -0.05	d_3 for countersunk screw ISO 7991	d_4 -0.05	b	h_1 ± 0.05	h_2	l_1 ± 0.05	l_2	w -0.1 stroke
32450.W0006	Left	5,0	6	M 3-3,2	3	8,5	4,25	3,2	7,5	3	1,5
32450.W0008	Left	6,5	8	M 4-4,3	4	10,5	5,25	4,2	9,5	4	1,8
32450.W0016	Right	5,0	6	M 3-3,2	3	8,5	4,25	3,2	7,5	3	1,5
32450.W0018	Right	6,5	8	M 4-4,3	4	10,5	5,25	4,2	9,5	4	1,8
32450.W0026	Centered	5,0	6	M 3-3,2	3	8,5	4,25	3,2	7,5	3	1,5
32450.W0028	Centered	6,5	8	M 4-4,3	4	10,5	5,25	4,2	9,5	4	1,8



Index Plungers - Pull Ring

non-locking - coarse thread

Index Plunger & Pins

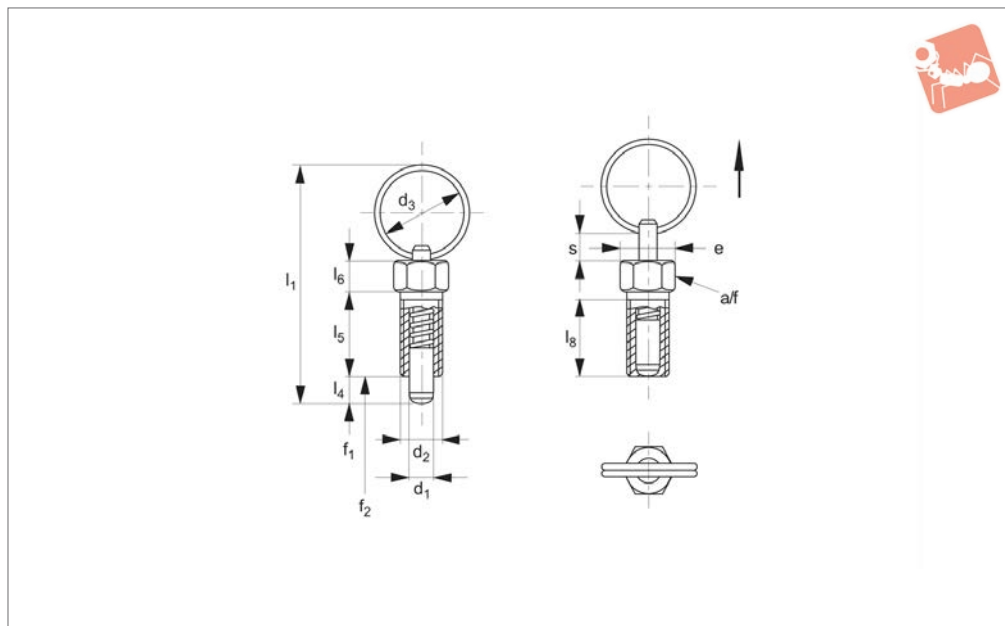

32550

INDEX PLUNGER & PINS

Material

Body: free cutting steel, galvanized.
 Pin: stainless steel 1.4305 (AISI 303).
 Pull Ring: stainless steel 1.4310 (AISI 301).

not required.

Coarse thread.

Temperature resistance up to 250°C

Lock nuts sold separately. See products 65690 and 65692

Technical Notes

For applications where high precision is

Tips

Spring loads * = statistical average

Order No.	Type	d ₁ tol. h9	d ₂	d ₃	e	l ₁	l ₄ =s min.	l ₅	l ₆	l ₈	A/F	Spring load	Spring load	Tightening torque	Weight
												F ₁ N ≈	F ₂ N ≈	Nm max.	g
32550.W0723	Non Locking	3	M 6x1,00	14	6,9	34,0	3,5	12	4,5	10,0	6	3	12	2	3,2
32550.W0724	Non Locking	4	M 6x1,00	14	6,9	34,5	4	12	4,5	10,0	6	3	12	2	3,6
32550.W0725	Non Locking	5	M 8x1,25	18	9,2	45,0	5	15	6,0	13,5	8	5	24	7	8,4
32550.W0726	Non Locking	6	M10x1,50	24	11,5	57,5	6	20	7,5	17,0	10	5	21	15	17,0
32550.W0728	Non Locking	8	M12x1,75	30	13,8	71,0	8	24	9,0	20,5	12	6	22	20	31,0





32551

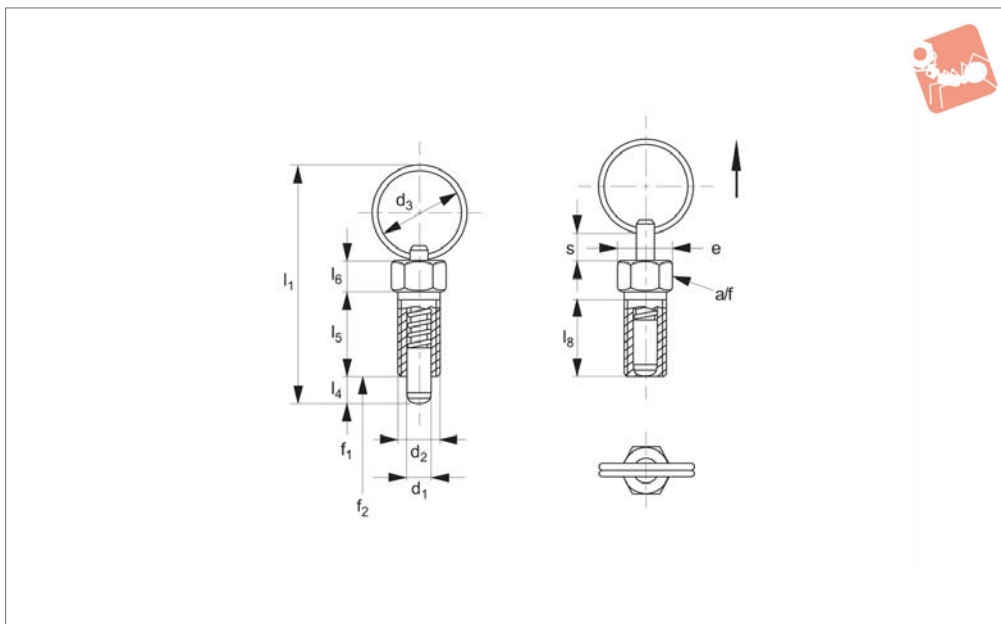

Material

Body: stainless steel 1.4305 (AISI 303).
 Pin: stainless steel 1.4305 (AISI 303).
 Pull ring: stainless steel 1.4310 (AISI 301).

Coarse thread.

Temperature resistance up to 250°C
Lock nuts sold separately. See products 65690 and 65692

Technical Notes

For applications where high precision is not required.

Tips

Spring loads * = statistical average.

Order No.	Type	d_1 tol. h9	d_2	d_3	e	l_1	$l_4 = s$ min.	l_5	l_6	l_8	A/F	Spring load		Tightening torque Nm max.	Weight g
												F_1 N ≈	F_2 N ≈		
32551.W0773	Non Locking	3	M 6x1,00	14	6,9	34,0	3,5	12	4,5	10,0	6	3	12	2	3,2
32551.W0774	Non Locking	4	M 6x1,00	14	6,9	34,5	4	12	4,5	10,0	6	3	12	2	3,6
32551.W0775	Non Locking	5	M 8x1,25	18	9,2	45,0	5	15	6,0	13,5	8	5	24	7	8,4
32551.W0776	Non Locking	6	M10x1,50	24	11,5	57,5	6	20	7,5	17,0	10	5	21	15	17,0
32551.W0778	Non Locking	8	M12x1,75	30	13,8	71,0	8	24	9,0	20,5	12	6	22	30	31,0





Index Plungers - Pull Grip

steel - coarse thread

Index Plunger & Pins

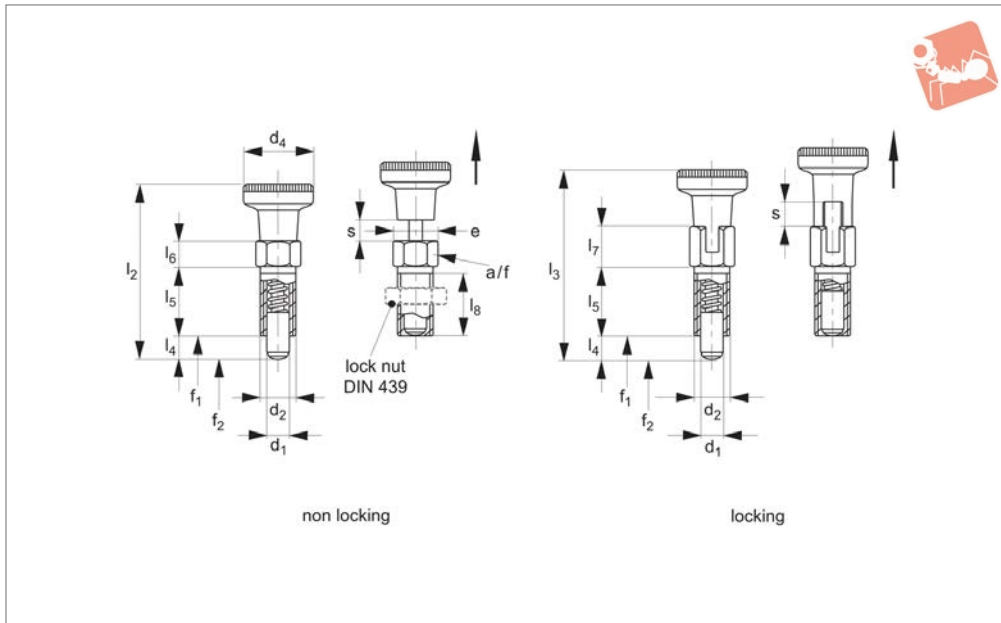

32570

INDEX PLUNGER & PINS

Material

Body: steel, galvanized.

Pin: stainless steel 1.4305 (AISI 303).

Grip: thermoplastic PA 6, black.

back grip, turn 90° to engage ,locking' on a notched catch.

„Non Locking“ type- pin simply springs back when grip released.

Temperature resistance -30° C to +80° C.

Lock nuts sold separately. See products 65690 and 65692

Tips

Grip non-removable.

Spring loads * = statistical average.

Technical Notes

„Locking“ type- enable pin to be held in retracted/non-projecting position; pull

For applications where high precision is not required.

Coarse thread.

Order No.	Type	Material	d ₁	d ₂	d ₄	l ₂	l ₃	Weight g
32570.W0743	Non Lock	-	3	M 6x1,00	12	30.0	-	3.6
32570.W0744	Non Lock	Steel	4	M 6x1,00	12	30.5	-	4.0
32570.W0745	Non Lock	Steel	5	M 8x1,25	16	40.0	-	9.2
32570.W0746	Non Lock	Steel	6	M10x1,50	18	49.0	-	18.0
32570.W0748	Non Lock	Steel	8	M12x1,75	21	59.0	-	32.0
32570.W0763	Lock	-	3	M 6x1,00	12	-	32.5	3.8
32570.W0764	Lock	Steel	4	M 6x1,00	12	-	33.0	4.2
32570.W0765	Lock	Steel	5	M 8x1,25	16	-	43.5	9.8
32570.W0766	Lock	Steel	6	M10x1,50	18	-	52.0	18.0
32570.W0768	Lock	Steel	8	M12x1,75	21	-	63.5	32.0

Order No.	l ₄ =s	l ₅	l ₆	l ₇	l ₈	e	A/F	Spring load F ₁ N	Spring load F ₂ N	Tightening torque Nm
32570.W0743	3.5	12	4.5	-	10.0	6.9	6	3	12	2
32570.W0744	4	12	4.5	-	10.0	6.9	6	3	12	2
32570.W0745	5	16	6.0	-	13.5	9.2	8	5	24	7
32570.W0746	6	20	7.5	-	17.0	11.5	10	5	21	15
32570.W0748	8	24	9.0	-	20.5	13.8	12	6	22	20
32570.W0763	3.5	12	-	7.0	10.0	6.9	6	3	12	2
32570.W0764	4	12	-	7.0	10.0	6.9	6	3	12	2
32570.W0765	5	16	-	9.5	13.5	9.2	8	5	24	7
32570.W0766	6	20	-	10.5	17.0	11.5	10	5	21	15
32570.W0768	8	24	-	13.5	20.5	13.8	12	6	22	20



32494

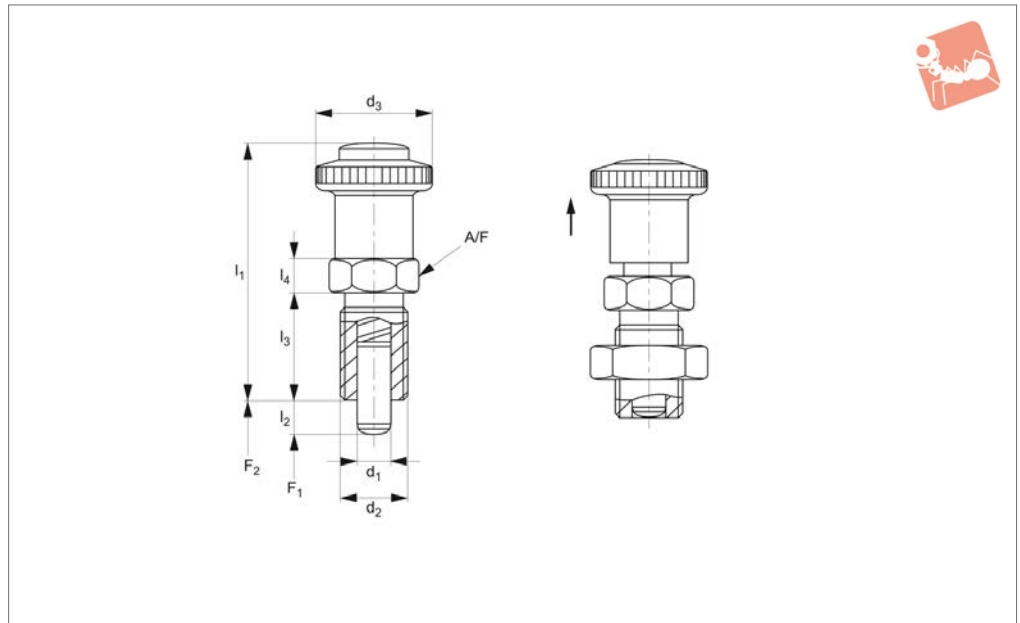

Material

Body: steel, blackened or stainless steel 1.4305.

Knob: thermoplastic, black-grey, matt.

Button: thermoplastic POM, red.

Locking pin: steel, hardened or stainless steel, nickel-plated.

Technical Notes

Press red button and hold whilst pulling

knob to release pin.

Temperature range -30 to +80°C.

Tips

Knob is non removable.

Lock nuts available separately.

Used with:

32510 Mounting blocks.

32700 Lock nut.

32750 Distance collars.

32752 Locating bushes.

32753 Locating bushes.

Order No.	Type	d_1 -0.02 -0.04	d_2	d_3	l_1 ≈	l_2 min.	l_3	l_4	A/F	Spring load F_1 N ≈	Spring load F_2 N ≈	Weight g
32494.W0005	Steel	6	M12x1,5	28	56	6	22	6	19	6.5	19	44
32494.W0010	Steel	6	M12x1,5	28	56	9	22	6	19	6.0	25	45
32494.W0015	Steel	8	M16x1,5	28	62	8	26	8	19	8.5	26	70
32494.W0020	Steel	8	M16x1,5	28	62	12	26	8	19	8.5	28	72
32494.W0025	Steel	10	M16x1,5	28	62	12	26	8	19	9.5	38	74
32494.W0105	Stainless	6	M12x1,5	28	56	6	22	6	19	6.5	19	44
32494.W0110	Stainless	6	M12x1,5	28	56	9	22	6	19	6.0	25	45
32494.W0115	Stainless	8	M16x1,5	28	62	8	26	8	19	8.5	26	70
32494.W0120	Stainless	8	M16x1,5	28	62	12	26	8	19	8.5	28	72
32494.W0125	Stainless	10	M16x1,5	28	62	12	26	8	19	9.5	38	74



Index Plungers -Pull Grip

Rapid locking head

Index Plunger & Pins

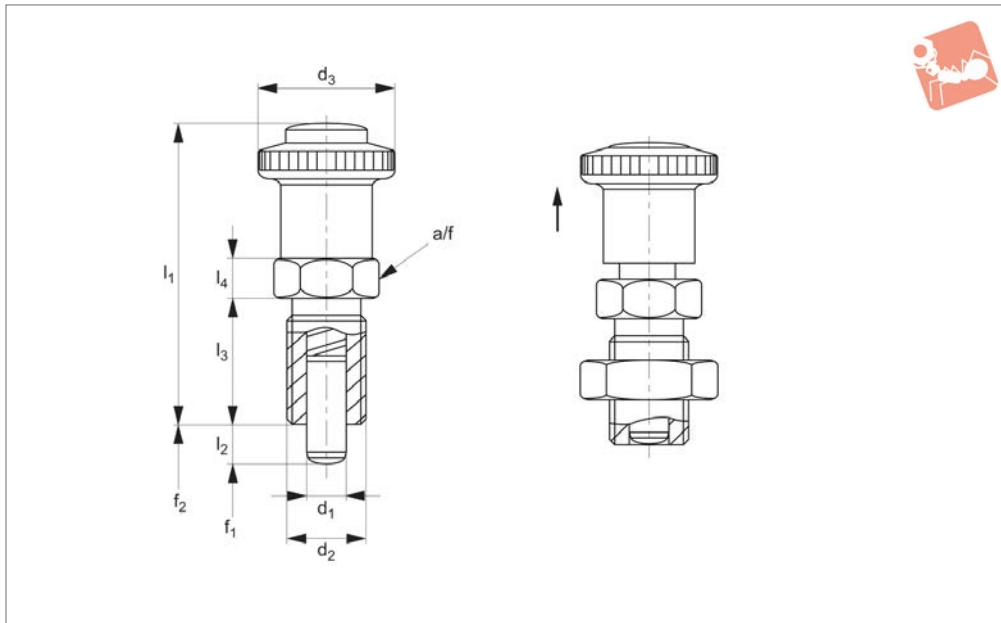

32495

INDEX PLUNGER & PINS

Material

Body:
 Steel: Steel, blackened.
 Stainless: Stainless steel 1.4305.
 Knob: thermoplastic, black-grey, matt.
 Button: thermoplastic POM, red.
 Locking pin. Steel: hardened.
 Stainless: stainless steel 1.4305, nickel-plated.

Technical Notes

Pull knob up, red button flush = pin locked.
 Press red button, red button out = pin unlocked.
 Temperature range -30 to +80 °C.

Tips

Knob is non removable.
 Lock nuts available separately.

Used with:
 32510 Mounting blocks.
 32700 Lock nut .
 32750 Distance collars.
 32752 Locating bushes.
 32753 Locating bushes.

Order No.	Type	d_1 -0.02 -0.04	d_2	d_3	l_1 ≈	l_2 min.	l_3	l_4	A/F	Spring load F_1 N ≈	Spring load F_2 N ≈	Weight g
32495.W0205	Steel	6	M12x1,5	30	53.5	6	22	6	19	6.5	19	47
32495.W0210	Steel	6	M12x1,5	30	53.5	9	22	6	19	6.0	25	48
32495.W0215	Steel	8	M16x1,5	30	59.5	8	26	8	19	8.5	26	74
32495.W0220	Steel	8	M16x1,5	30	59.5	12	26	8	19	8.5	28	77
32495.W0225	Steel	10	M16x1,5	30	59.5	12	26	8	19	9.5	38	78
32495.W0305	Stainless	6	M12x1,5	30	53.5	6	22	6	19	6.5	19	47
32495.W0310	Stainless	6	M12x1,5	30	53.5	9	22	6	19	6.0	25	48
32495.W0315	Stainless	8	M16x1,5	30	59.5	8	26	8	19	8.5	26	74
32495.W0320	Stainless	8	M16x1,5	30	59.5	12	26	8	19	8.5	28	77
32495.W0325	Stainless	10	M16x1,5	30	59.5	12	26	8	19	9.5	38	78



32571

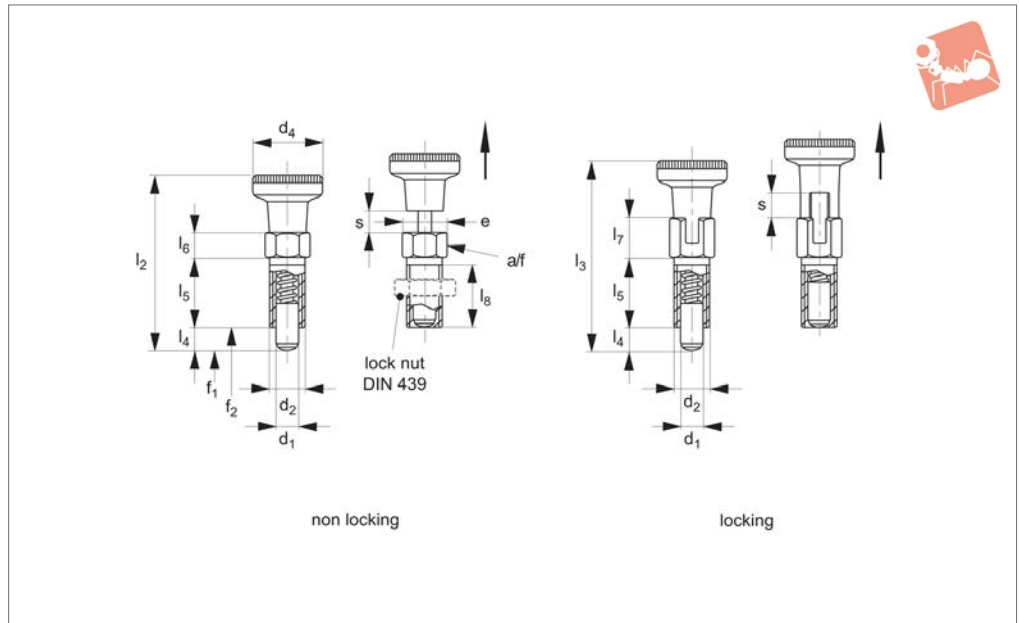

Material

Body: stainless steel 1.4305 (AISI 303).
 Pin: stainless steel 1.4305 (AISI 303).
 Grip: thermoplastic PA 6, black.

Technical Notes

„Locking“ type- enable pin to be held in

retracted/non-projecting position; pull back grip, turn 90° to engage „locking“ on a notched catch.

„Non Locking“ type- pin simply springs back when grip released.

For applications where high precision is

not required.

Coarse thread.

Temperature resistance -30° C to +80° C.

Tips

Grip non-removable.

Spring loads * = statistical average.

Order No.	Type	Material	d ₁ tol. h9	d ₂	d ₄	l ₂	l ₃	l ₄ =s min.	l ₅	l ₆	l ₇	l ₈	e	A/F	Spring load F ₁ N ≈	Spring load F ₂ N ≈	Tightening torque Nm max.	Weight g
32571.W0783	Non Lock	Stainless	3	M 6x1,00	12	30,0	3,5	12	4,5	10,0	6,9	6	3	12	2	3,2		
32571.W0784	Non Lock	Stainless	4	M 6x1,00	12	30,5	4,0	12	4,5	10,0	6,9	6	3	12	2	4,0		
32571.W0785	Non Lock	Stainless	5	M 8x1,25	16	40,0	5,0	16	6,0	13,5	9,2	8	5	24	7	9,2		
32571.W0786	Non Lock	Stainless	6	M10x1,50	18	49,0	6,0	20	7,5	17,0	11,5	10	5	21	15	18,0		
32571.W0788	Non Lock	Stainless	8	M12x1,75	21	59,0	8,0	24	9,0	20,5	13,8	12	6	22	20	32,0		
32571.W0793	Lock	Stainless	3	M 6x1,00	12	32,5	3,5	12	7,0	10,0	6,9	6	3	12	2	3,8		
32571.W0794	Lock	Stainless	4	M 6x1,00	12	33,0	4,0	12	7,0	10,0	6,9	6	3	12	2	4,2		
32571.W0795	Lock	Stainless	5	M 8x1,25	16	43,5	5,0	16	9,5	13,5	9,2	8	5	24	7	9,8		
32571.W0796	Lock	Stainless	6	M10x1,50	18	52,0	6,0	20	10,5	17,0	11,5	10	5	21	15	18,0		
32571.W0798	Lock	Stainless	8	M12x1,75	21	63,5	8,0	24	13,5	20,5	13,8	12	6	22	20	32,0		



Index Plungers - Pull Grip

compact - non-locking

Index Plunger & Pins

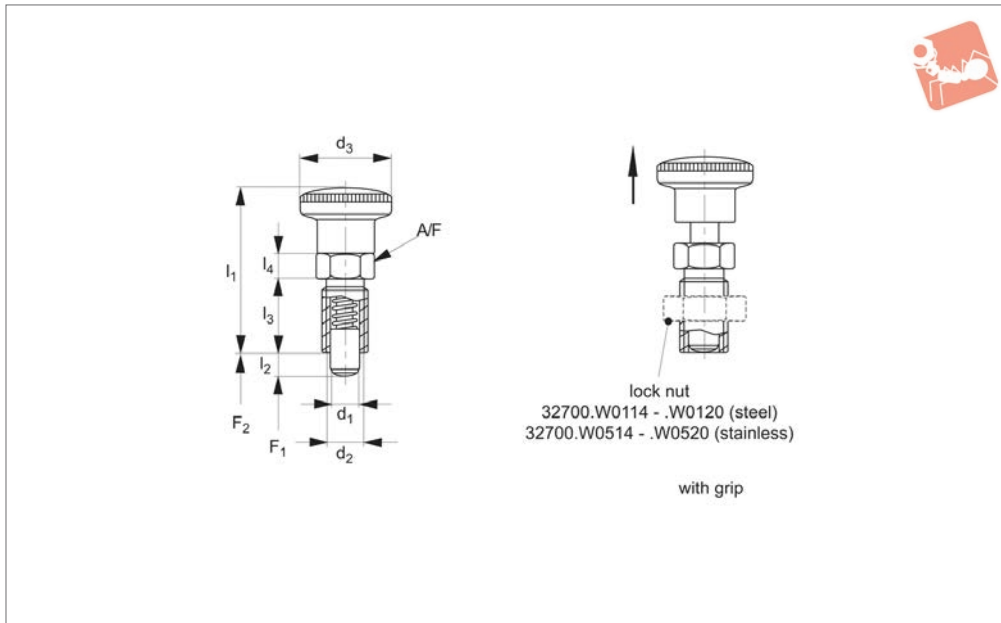

32680

INDEX PLUNGER & PINS

Material

Free cutting steel type-

Body: free cutting steel, blackened.

Pin: steel, hardened.

Grip: thermoplastic PA6, black.

Stainless steel type -

Body: stainless steel 1.4305 (AISI 303).

Pin: stainless steel 1.4305 (AISI 303), nickel plated.

Grip: thermoplastic PA6, black.

Technical Notes

„Non Locking“ type- pin simply springs back when grip released.

Thread recess on body allows full engagement of thread length. Hexagon collar improves leverage for secure installation. Benefits from a more compact design and hence shorter overall length.

Temperature resistance from -30° to +80°C.

Distance collars no. 32750 can be used to adapt screw length.

Lock nuts sold separately. See products 65690 and 65692

Tips

Grip non-removable.

Spring loads * = statistical average.

Order No.	Type	Material	d ₁ -0.02 -0.04	d ₂	d ₃	l ₁	l ₂ min.	l ₃	l ₄	A/F	Spring load F ₁ N ≈	Spring load F ₂ N ≈	Weight g
32680.W0103	No Lock	Steel	4	M 8x1,0	16	35.0	4	16	5	10	4.5	12.0	10
32680.W0104	No Lock	Steel	4	M 8x1,0	16	35.0	6	16	5	10	4.0	12.5	10
32680.W0106	No Lock	Steel	5	M10x1,0	19	40.0	5	18	6	12	5.0	15.5	18
32680.W0107	No Lock	Steel	5	M10x1,0	19	40.0	8	18	6	12	5.0	18.0	18
32680.W0109	No Lock	Steel	6	M12x1,5	23	48.0	6	22	6	14	6.5	19.0	29
32680.W0110	No Lock	Steel	6	M12x1,5	23	48.0	9	22	6	14	6.0	25.0	29
32680.W0112	No Lock	Steel	8	M16x1,5	28	58.0	8	26	8	17	8.5	26.0	62
32680.W0113	No Lock	Steel	8	M16x1,5	28	58.0	12	26	8	17	8.5	28.0	62
32680.W0115	No Lock	Steel	10	M16x1,5	28	58.0	12	26	8	17	9.5	38.0	63
32680.W0116	No Lock	Steel	12	M20x1,5	33	67.0	15	33	10	22	11.5	40.0	117
32680.W0117	No Lock	Steel	16	M24x 2	33	78.5	20	38	12	27	13.0	54.0	204
32680.W0203	No Lock	Stainless	4	M 8x1,0	16	35.0	4	16	5	10	4.5	12.0	10
32680.W0204	No Lock	Stainless	4	M 8x1,0	16	35.0	6	16	5	10	4.0	12.5	10
32680.W0206	No Lock	Stainless	5	M10x1,0	19	40.0	5	18	6	12	5.0	15.5	18
32680.W0207	No Lock	Stainless	5	M10x1,0	19	40.0	8	18	6	12	5.0	18.0	18
32680.W0209	No Lock	Stainless	6	M12x1,5	23	48.0	6	22	6	14	6.5	19.0	29
32680.W0210	No Lock	Stainless	6	M12x1,5	23	48.0	9	22	6	14	6.0	25.0	29
32680.W0212	No Lock	Stainless	8	M16x1,5	28	58.0	8	26	8	17	8.5	26.0	62
32680.W0213	No Lock	Stainless	8	M16x1,5	28	58.0	12	26	8	17	8.5	28.0	62
32680.W0215	No Lock	Stainless	10	M16x1,5	28	58.0	12	26	8	17	9.5	38.0	63
32680.W0216	No Lock	Stainless	12	M20x1,5	33	67.0	15	33	10	22	11.5	40.0	117
32680.W0217	No Lock	Stainless	16	M24x 2	33	78.5	20	38	12	27	-	-	204

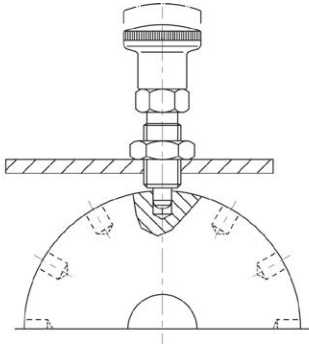



Index Plungers - No Grip

compact - non-locking

Index Plunger & Pins

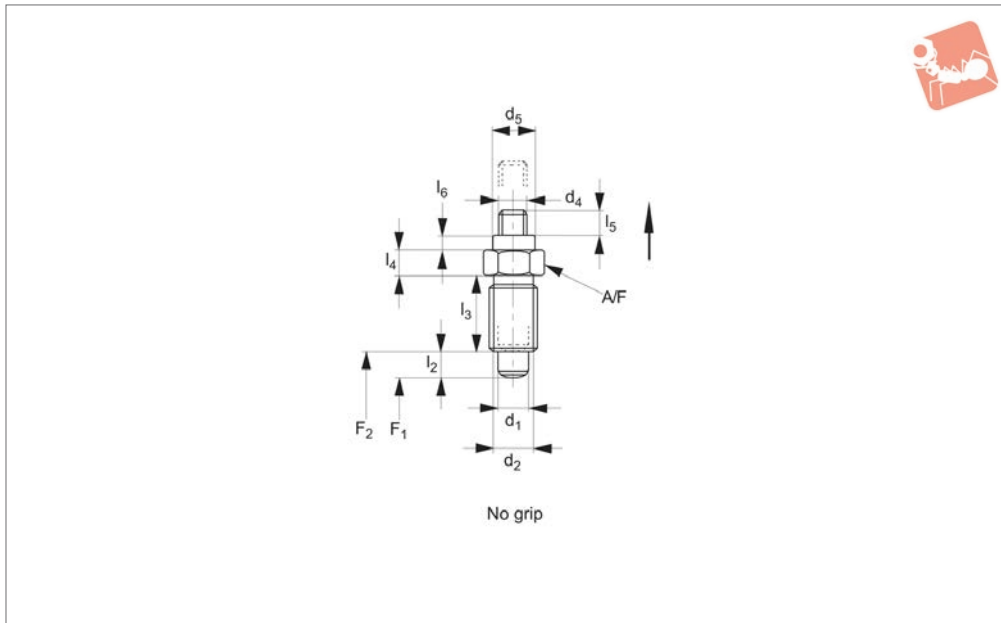

32681

INDEX PLUNGER & PINS

Material

Free cutting steel type-

Body: free cutting steel, blackened.

Pin: steel, hardened.

Stainless steel type -

Body: stainless steel 1.4305 (AISI 303).

Pin: stainless steel 1.4305 (AISI 303), nickel plated.

Technical Notes

„Non Locking“ type- pin simply springs

back when grip released.

Thread recess on body allows full engagement of thread length. Hexagon collar improves leverage for secure installation.

Benefits from a more compact design and hence shorter overall length.

Temperature resistance up to 250°C

Distance collars no. 32750 can be used to adapt screw length.

Lock nuts sold separately See products 65690 & 65692

Tips

Spring loads * = statistical average. Threaded head of d_4 enables use of larger handle or grip better suited to your application. See palm grip no. 70000, or similar.

Order No.	Type	Material	d_1	d_2	d_4	d_5	l_2	l_3	l_4	l_5	l_6	A/F	Spring load F_1 N	Spring load F_2 N	Weight g
32681.W0143	No Grip	Steel	4	M 8x1,0	M 3	7	4	16	5	4.5	2.5	10	4.5	12.0	9
32681.W0144	No Grip	Steel	4	M 8x1,0	M 3	7	6	16	5	4.5	2.5	10	4.0	12.5	9
32681.W0146	No Grip	Steel	5	M10x1,0	M 4	8	5	18	6	5.5	3.0	12	5.0	15.0	16
32681.W0147	No Grip	Steel	5	M10x1,0	M 4	8	8	18	6	5.5	3.0	12	5.0	18.0	16
32681.W0149	No Grip	Steel	6	M12x1,5	M 5	9	6	22	6	7.0	3.5	14	6.5	19.0	25
32681.W0150	No Grip	Steel	6	M12x1,5	M 5	9	9	22	6	7.0	3.5	14	6.0	25.0	25
32681.W0152	No Grip	Steel	8	M16x1,5	M 6	10	8	26	8	8.5	4.0	17	8.5	26.0	55
32681.W0153	No Grip	Steel	8	M16x1,5	M 6	10	12	26	8	8.5	4.0	17	8.5	28.0	55
32681.W0155	No Grip	Steel	10	M16x1,5	M 6	10	12	26	8	8.5	4.0	17	9.5	38.0	56
32681.W0156	No Grip	Steel	12	M20x1,5	M 6	12	15	33	10	8.5	4.0	22	11.5	40.0	111
32681.W0157	No Grip	Steel	16	M24 x 2	M 8	15	20	38	12	11.5	5.0	27	13.0	54.0	194
32681.W0243	No Grip	Stainless	4	M 8x1,0	M 3	7	4	16	5	4.5	2.5	10	4.5	12.0	9
32681.W0244	No Grip	Stainless	4	M 8x1,0	M 3	7	6	16	5	4.5	2.5	10	4.0	12.5	9
32681.W0246	No Grip	Stainless	5	M10x1,0	M 4	8	5	18	6	5.5	3.0	12	5.0	15.0	16
32681.W0247	No Grip	Stainless	5	M10x1,0	M 4	8	8	18	6	5.5	3.0	12	5.0	18.0	16
32681.W0249	No Grip	Stainless	6	M12x1,5	M 5	9	6	22	6	7.0	3.5	14	6.5	19.0	25
32681.W0250	No Grip	Stainless	6	M12x1,5	M 5	9	9	22	6	7.0	3.5	14	6.0	25.0	25
32681.W0252	No Grip	Stainless	8	M16x1,5	M 6	10	8	26	8	8.5	4.0	17	8.5	26.0	55
32681.W0253	No Grip	Stainless	8	M16x1,5	M 6	10	12	26	8	8.5	4.0	17	8.5	28.0	55
32681.W0255	No Grip	Stainless	10	M16x1,5	M 6	10	12	26	8	8.5	4.0	17	9.5	38.0	56
32681.W0256	No Grip	Stainless	12	M20x1,5	M 6	12	15	33	10	8.5	4.0	22	11.5	40.0	111
32681.W0257	No Grip	Stainless	16	M24 x 2	M 8	15	20	38	12	11.5	5.0	27	13.0	54.0	194



32690

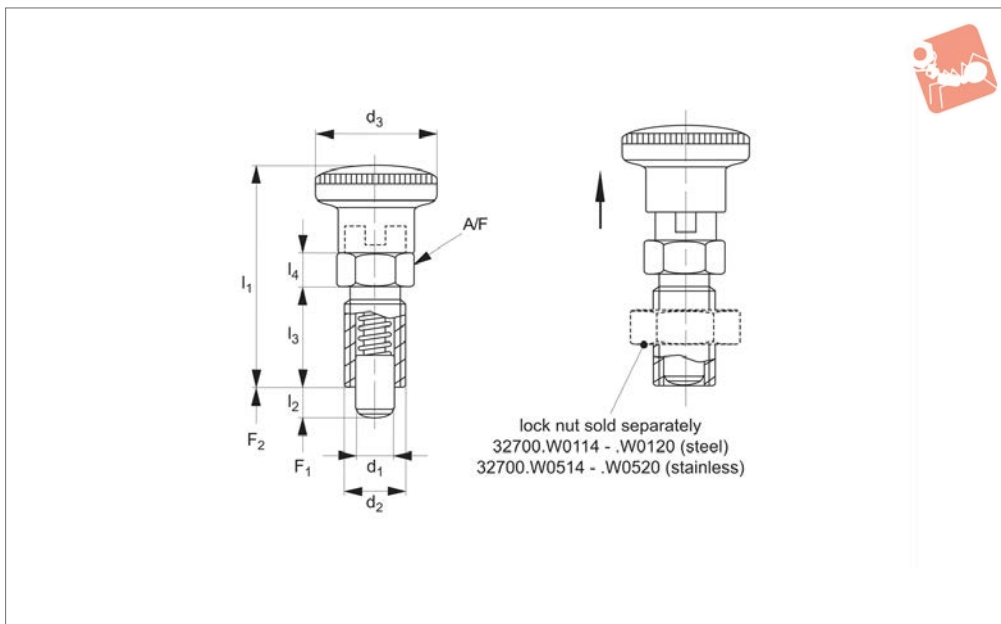

Material

Free cutting steel type-

Body: free cutting steel, blackened.

Pin: steel, hardened.

Grip: thermoplastic PA6, black.

Stainless steel type -

Body: stainless steel 1.4305 (AISI 303).

Pin: stainless steel 1.4305 (AISI 303),

nickel plated.

Grip: thermoplastic PA6, black.

Technical Notes

„Locking“ type- enable pin to be held in

retracted/non-projecting position; pull back grip, turn 90° to engage ‚locking‘ on a notched catch.

Thread recess on body allows full engagement of thread length. Hexagon collar improves leverage for secure installation. Benefits from a more compact design and hence shorter overall length.

Temperature resistance from -30° to +80°C.

adapt screw length.

Lock nuts sold separately See products 65690 & 65692

Tips

Grip non-removable.

Spring loads * = statistical average.

Distance collars no. 32750 can be used to

Order No.	Type	Material	d_1 -0.02 -0.04	d_2	d_3	l_1	l_2 min.	l_3	l_4	A/F	Spring load F_1 N ~	Spring load F_2 N ~	Weight g
32690.W0123	Locking	Steel	4	M 8x1,0	16	35	4	16	5	10	4.5	12.0	12.0
32690.W0124	Locking	Steel	4	M 8x1,0	16	35	6	16	5	10	4.0	12.5	12.0
32690.W0126	Locking	Steel	5	M10x1,0	19	40	5	18	6	12	5.0	15.0	20.0
32690.W0127	Locking	Steel	5	M10x1,0	19	40	8	18	6	12	5.0	18.0	20.0
32690.W0129	Locking	Steel	6	M12x1,5	23	48	6	22	6	14	6.5	19.0	31.0
32690.W0130	Locking	Steel	6	M12x1,5	23	48	9	22	6	14	6.0	25.0	33.0
32690.W0132	Locking	Steel	8	M16x1,5	28	58	8	26	8	17	8.5	26.0	65.0
32690.W0133	Locking	Steel	8	M16x1,5	28	58	12	26	8	17	8.5	28.0	68.0
32690.W0135	Locking	Steel	10	M16x1,5	28	58	12	26	8	17	9.5	38.0	69.0
32690.W0136	Locking	Steel	12	M20x1,5	33	67	15	33	10	22	11.5	40.0	125.0
32690.W0137	Locking	Steel	16	M24 x 2	33	78.5	20	38	12	27	13.0	54.0	220
32690.W0223	Locking	Stainless	4	M 8x1,0	16	35	4	16	5	10	4.5	12.0	12.0
32690.W0224	Locking	Stainless	4	M 8x1,0	16	35	6	16	5	10	4.0	12.5	12.0
32690.W0226	Locking	Stainless	5	M10x1,0	19	40	5	18	6	12	5.0	15.0	20.0
32690.W0227	Locking	Stainless	5	M10x1,0	19	40	8	18	6	12	5.0	18.0	20.0
32690.W0229	Locking	Stainless	6	M12x1,5	23	48	6	22	6	14	6.5	19.0	31.0
32690.W0230	Locking	Stainless	6	M12x1,5	23	48	9	22	6	14	6.0	25.0	33.0
32690.W0232	Locking	Stainless	8	M16x1,5	28	58	8	26	8	17	8.5	26.0	65.0
32690.W0233	Locking	Stainless	8	M16x1,5	28	58	12	26	8	17	8.5	28.0	68.0
32690.W0235	Locking	Stainless	10	M16x1,5	28	58	12	26	8	17	9.5	38.0	69.0
32690.W0236	Locking	Stainless	12	M20x1,5	33	67	15	33	10	22	11.5	40.0	125.0
32690.W0237	Locking	Stainless	16	M24 x 2	33	78.5	20	38	12	27	13.0	54.0	220

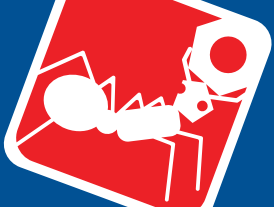

Index Plungers - Compact

compact -locking

Index Plunger & Pins

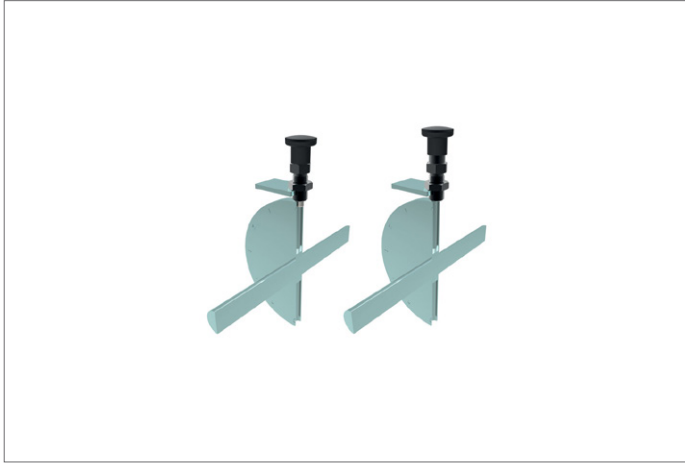

INDEX PLUNGER & PINS



32700

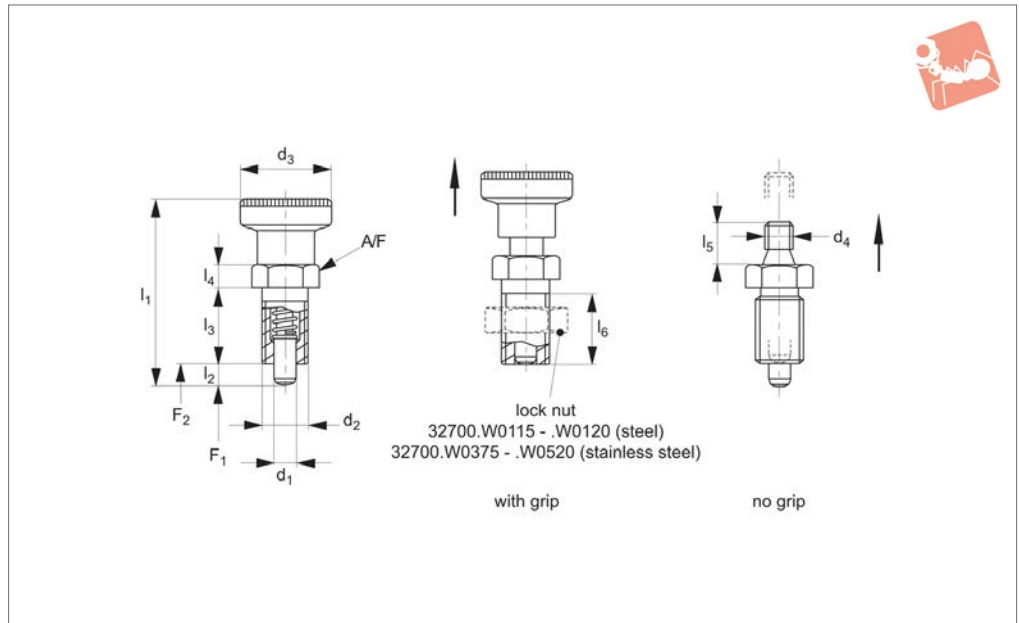

Material

Free cutting steel type-

Body: free cutting steel, blackened.

Pin: steel, hardened.

Grip: thermoplastic PA6, black.

Stainless steel type -

Body: stainless steel 1.4305 (AISI 303).

Pin: stainless steel 1.4305 (AISI 303), nickel plated.

Grip: thermoplastic PA6, black.

Technical Notes

„Non Locking“ type- pin simply springs back when pull ring released.

Thread recess on body allows full engagement of thread length. Hexagon collar improves leverage for secure installation. Without grip temperature resistance up to 250°C.

Distance collars no. 32750 can be used to adapt screw length.

Lock nuts sold separately See Products 65690 and 65692

Tips

Grip non-removable.

Spring loads * = statistical average.

Order No.	Type	Material	d ₁ -0.02 -0.04	d ₂	d ₃	d ₄	l ₁ ≈	l ₂ min.	l ₃	l ₄	l ₅	l ₆ min.	A/F	Spring load		Weight g
														F ₁ N ≈	F ₂ N ≈	
32700.W0005	With Grip	Steel	5	M10x1,0	21		45,0	5	17	5		15	12	6,0	14	19,0
32700.W0006	With Grip	Steel	6	M12x1,5	25		54,5	6	20	6		17	14	5,5	13	31,0
32700.W0008	With Grip	Steel	8	M16x1,5	31		69,0	8	26	8		23	19	11,5	28	71,0
32700.W0010	With Grip	Steel	10	M20x1,5	31		80,0	10	33	10		30	22	23,0	54	115,0
32700.W0025	No Grip	Steel	5	M10x1,0		M 5		5	17	5	6	15	12	6,0	14	14,0
32700.W0026	No Grip	Steel	6	M12x1,5		M 6		6	20	6	10	17	14	5,5	13	23,0
32700.W0028	No Grip	Steel	8	M16x1,5		M 8		8	26	8	12	23	19	11,5	28	54,0
32700.W0030	No Grip	Steel	10	M20x1,5		M 8		10	33	10	12	30	22	23,0	54	79,0
32700.W0405	With Grip	Stainless	5	M10x1,0	21		45,0	5	17	5		15	12	6,0	14	19,0
32700.W0406	With Grip	Stainless	6	M12x1,5	25		54,5	6	20	6		17	14	5,5	13	31,0
32700.W0408	With Grip	Stainless	8	M16x1,5	31		69,0	8	26	8		23	19	11,5	28	71,0
32700.W0410	With Grip	Stainless	10	M20x1,5	31		80,0	10	33	10		30	22	23,0	54	115,0
32700.W0425	No Grip	Stainless	5	M10x1,0		M 5		5	17	5	6	15	12	6,0	14	14,0
32700.W0426	No Grip	Stainless	6	M12x1,5		M 6		6	20	6	10	17	14	5,5	13	23,0
32700.W0428	No Grip	Stainless	8	M16x1,5		M 8		8	26	8	12	23	19	11,5	28	54,0
32700.W0430	No Grip	Stainless	10	M20x1,5		M 8		10	33	10	12	30	22	23,0	54	79,0



Index Plungers - Pull Grip

non-locking - ALL stainless

Index Plunger & Pins

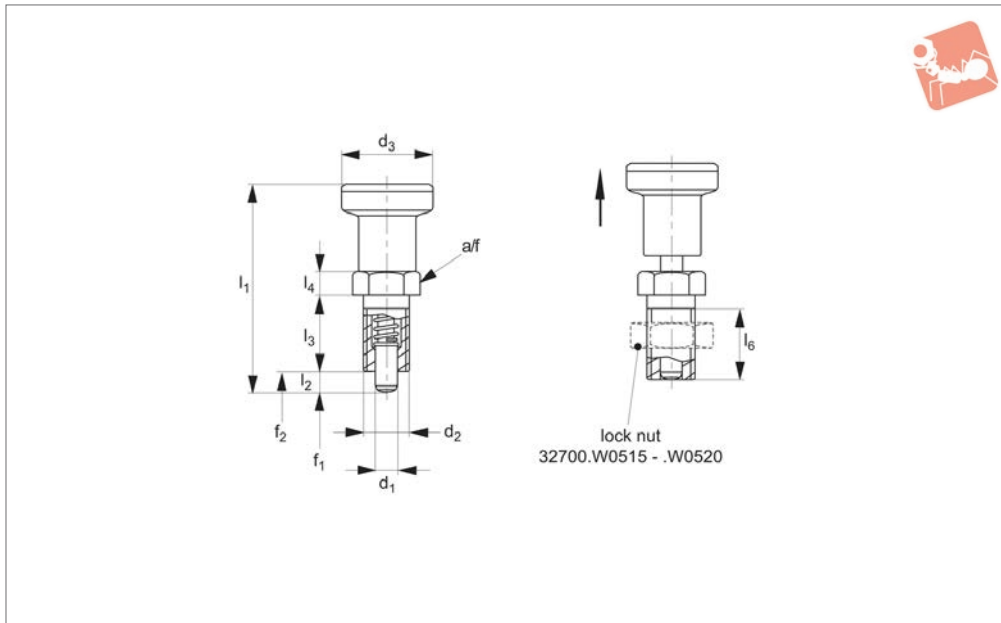

32702

INDEX PLUNGER & PINS

Material

All Stainless Steel Type-

Body: stainless steel 1.4305 (AISI 303).
 Pin: stainless steel 1.4305 (AISI 303),
 nickel plated.
 Grip: stainless steel 1.4305 (AISI 303).
 Spring: stainless steel 1.4310 (AISI 301).

Technical Notes

„Non Locking“ type- pin simply springs

back when pull ring released.
 Thread recess on body allows full engagement of thread length. Hexagon collar improves leverage for secure installation. Temperature resistance from -30° to +80°C.
 Distance collars no. 32750 can be used to adapt screw length.

Lock nuts sold separately. See Products 65690 and 65692

Tips

Complete stainless steel construction designed with specific demands of food processing, pharmaceutical and water treatment industries in mind. Grip non-removable. Spring Loads* = statistical average.

Order No.	Type	d_1 -0.02 -0.04	d_2	d_3	l_1 ≈	l_2 min.	l_3	l_4	l_6 min.	A/F	Spring load F_1 N ≈	Spring load F_2 N ≈	Weight g
32702.W0705	Non locking	5	M10x1,0	21	45.0	5	17	5	15	12	6.0	14	39.0
32702.W0706	Non locking	6	M12x1,5	25	54.5	6	20	6	17	14	5.5	13	65.0
32702.W0707	Non locking	8	M16x1,5	31	69.0	8	26	8	23	19	11.5	28	132.0
32702.W0710	Non locking	10	M20x1,5	31	80.0	10	33	10	30	22	23.0	54	175.0



32710

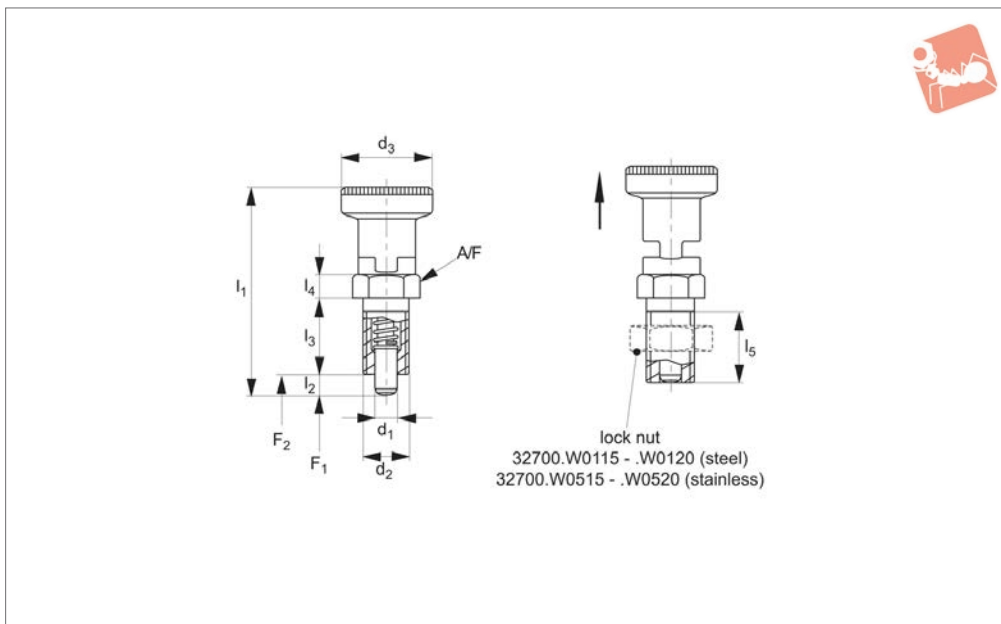

Material

Free cutting steel type-

Body: free cutting steel, blackened.

Pin: hardened steel.

Grip: thermoplastic PA6, black.

Stainless steel type -

Body: stainless steel 1.4305 (AISI 303).

Pin: stainless steel 1.4305 (AISI 303), nickel plated.

Grip: thermoplastic PA6, black.

Technical Notes

„**Locking**“ type- enable pin to be held in retracted/non-projecting position; pull back grip, turn 90° to engage ‚locking‘ on a notched catch.

Thread recess on body allows full engagement of thread length. Hexagon collar improves leverage for secure installation. Temperature resistance from -30° to +80°C.

Distance collars no. 32750 can be used to adapt screw length.

Lock nuts sold separately. See Products 65690 and 65692

Tips

Grip non-removable.

Spring loads * = statistical average.

Order No.	Type	Material	d_1 -0.02 -0.04	d_2	d_3	l_1 ≈	l_2 min.	l_3	l_4	l_5 min.	A/F	Spring load F_1 N ≈	Spring load F_2 N ≈	Weight g
32710.W0205	Locking	Steel	5	M10x1,0	21	51.0	5	17	5	15	12	6.0	14	22
32710.W0206	Locking	Steel	6	M12x1,5	25	61.0	6	20	6	17	14	5.5	13	36
32710.W0208	Locking	Steel	8	M16x1,5	31	75.5	8	26	8	23	19	1.5	28	79
32710.W0210	Locking	Steel	10	M20x1,5	31	91.0	10	33	10	30	22	28.0	54	134
32710.W0605	Locking	Stainless	5	M10x1,0	21	51.0	5	17	5	15	12	6.0	14	22
32710.W0606	Locking	Stainless	6	M12x1,5	25	61.0	6	20	6	17	14	5.5	13	36
32710.W0608	Locking	Stainless	8	M16x1,5	31	75.5	8	26	8	23	19	1.5	28	79
32710.W0610	Locking	Stainless	10	M20x1,5	31	91.0	10	33	10	30	22	28.0	54	134

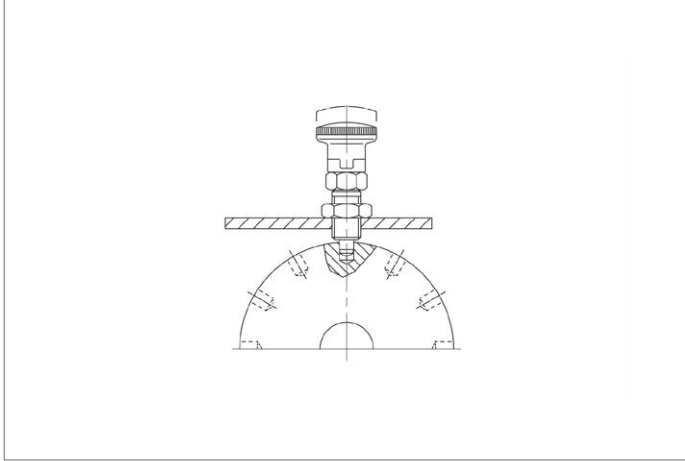
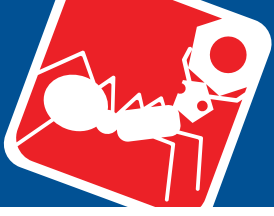



32712

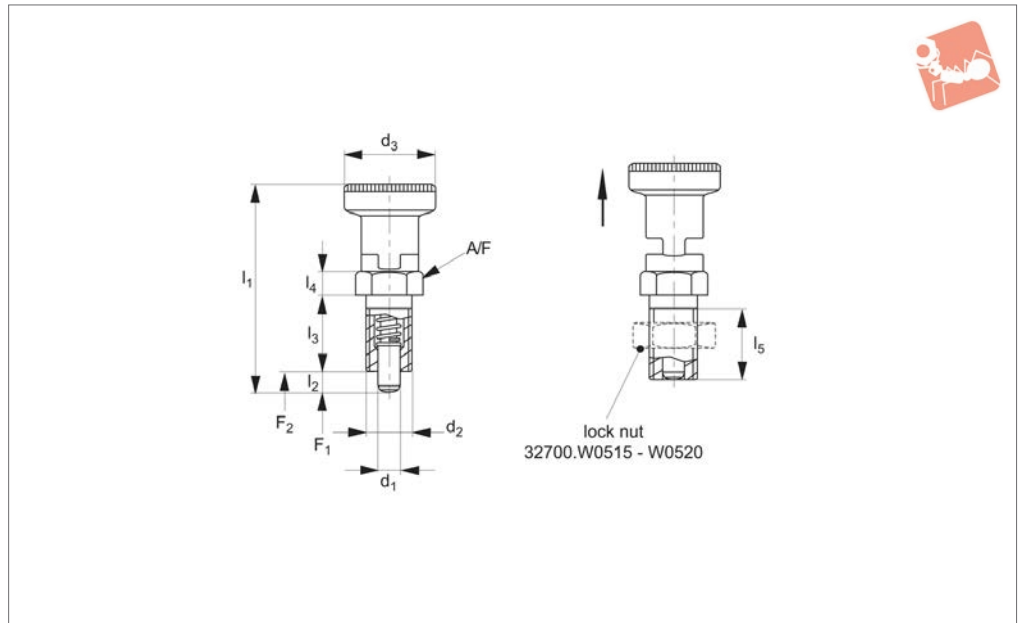

Material

All Stainless Steel Type-

Body: stainless steel 1.4305 (AISI 303).
 Pin: stainless steel 1.4305, nickel plated.
 Grip: stainless steel 1.4305 (AISI 303).
 Spring: stainless steel 1.4310 (AISI 301).

Technical Notes

„Locking“ type- enable pin to be held in retracted/non-projecting position; pull

back grip, turn 90° to engage ,locking‘ on a notched catch.

Thread recess on body allows full engagement of thread length. Hexagon collar improves leverage for secure installation. Temperature resistance from -30° to +80°C.

Distance collars no. 32750 can be used to adapt screw length.

Lock nuts sold separately. See Products 65690 and 65692

Tips

Complete stainless steel construction designed with specific demands of food processing, pharmaceutical and water treatment industries in mind. Grip non-removable. Spring Loads* = statistical average.

Order No.	Type	d ₁ -0.02 -0.04	d ₂	d ₃	l ₁ ≈	l ₂ min.	l ₃	l ₄	l ₅	A/F	Spring load F ₁ N ≈	Spring load F ₂ N ≈	Weight g
32712.W0705	Locking	5	M10x1,0	21	51.0	5	17	5	15	12	6.0	14	43
32712.W0706	Locking	6	M12x1,5	25	61.0	6	20	6	17	14	5.5	13	71
32712.W0708	Locking	8	M16x1,5	31	75.5	7	26	8	23	19	11.5	28	144
32712.W0710	Locking	10	M20x1,5	31	91.0	10	33	10	30	22	28.0	54	202



Index Plunger - Pull Grip non-locking

Index Plunger & Pins

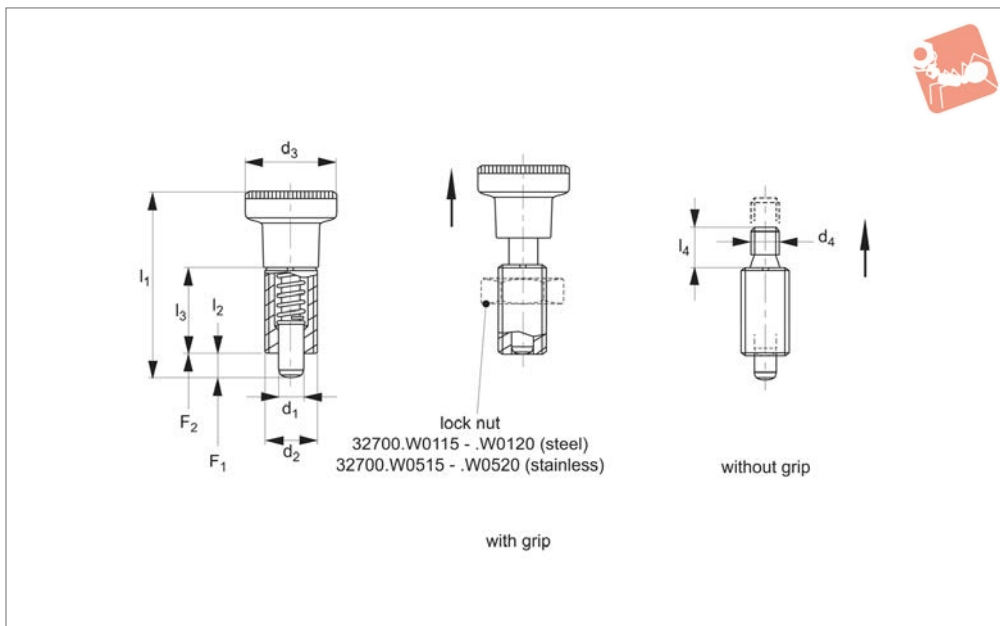

32740

INDEX PLUNGER & PINS

Material

Free Cutting Steel Type-

Body: free cutting steel, blackened.

Pin: steel, hardened.

Grip: thermoplastic PA6, black.

Stainless steel type -

Body: stainless steel 1.4305 (AISI 303).

Pin: stainless steel 1.4305 (AISI 303),
nickel plated.

Grip: thermoplastic PA6, black.

Technical Notes

„Non Locking“ type- pin simply springs
back when pull ring released.

Plungers without grip enable your own
adaptation with actuation grip/lever to
your own design. Installation requires use
of specific assembly tool, see data table.

Without grip temperature resistance up to
250°C.

Lock nuts sold separately. See Products
65690 and 65692

Tips

Grip non-removable.

Spring loads * = statistical average.

Order No.	Type	Material	d ₁	d ₂	d ₃	d ₄	l ₁	l ₂	l ₃	l ₄	Spring load F ₁ N	Spring load F ₂ N	Weight g
32740.W0045	With Grip	Steel	5	M10x1,0	21	-	45.0	5	22	-	6.0	14	17
32740.W0046	With Grip	Steel	6	M12x1,5	25	-	54.5	6	26	-	5.5	13	27
32740.W0048	With Grip	Steel	8	M16x1,5	31	-	69.0	8	34	-	11.5	28	63
32740.W0050	With Grip	Steel	10	M20x1,5	31	-	80.0	10	41	-	23.0	54	104
32740.W0065	No Grip	Steel	5	M10x1,0	-	M 5	-	5	22	6	6.0	14	12
32740.W0066	No Grip	Steel	6	M12x1,5	-	M 6	-	6	26	10	5.5	13	12
32740.W0068	No Grip	Steel	8	M16x1,5	-	M 8	-	8	34	12	11.5	28	46
32740.W0070	No Grip	Steel	10	M20x1,5	-	M 8	-	10	43	12	23.0	54	87
32740.W0445	With Grip	Stainless	5	M10x1,0	21	-	45.0	5	22	-	6.0	14	17
32740.W0446	With Grip	Stainless	6	M12x1,5	25	-	54.5	6	26	-	5.5	13	27
32740.W0448	With Grip	Stainless	8	M16x1,5	31	-	69.0	8	34	-	11.5	28	63
32740.W0450	With Grip	Stainless	10	M20x1,5	31	-	80.0	10	41	-	23.0	54	104
32740.W0465	No Grip	Stainless	5	M10x1,0	-	M 5	-	5	22	6	6.0	14	12
32740.W0466	No Grip	Stainless	6	M12x1,5	-	M 6	-	6	26	10	5.5	13	12
32740.W0468	No Grip	Stainless	8	M16x1,5	-	M 8	-	8	34	12	11.5	28	46
32740.W0470	No Grip	Stainless	10	M20x1,5	-	M 8	-	10	43	12	23.0	54	87
32740.W0955	Assembly Tool	Steel	-	for M10x1,0	-	-	-	-	-	-	-	-	10
32740.W0956	Assembly Tool	Steel	-	for M12x1,5	-	-	-	-	-	-	-	-	14
32740.W0958	Assembly Tool	Steel	-	for M16x1,5	-	-	-	-	-	-	-	-	25
32740.W0960	Assembly Tool	Steel	-	for M20x1,5	-	-	-	-	-	-	-	-	27

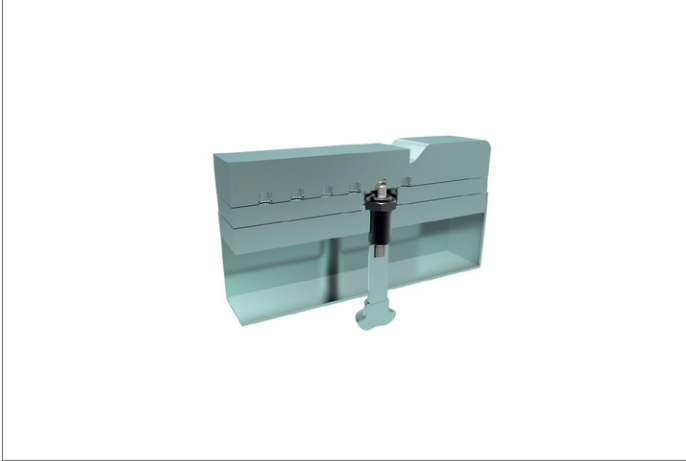



Index Plunger - Pull Grip

non-locking - ALL stainless

Index Plunger & Pins

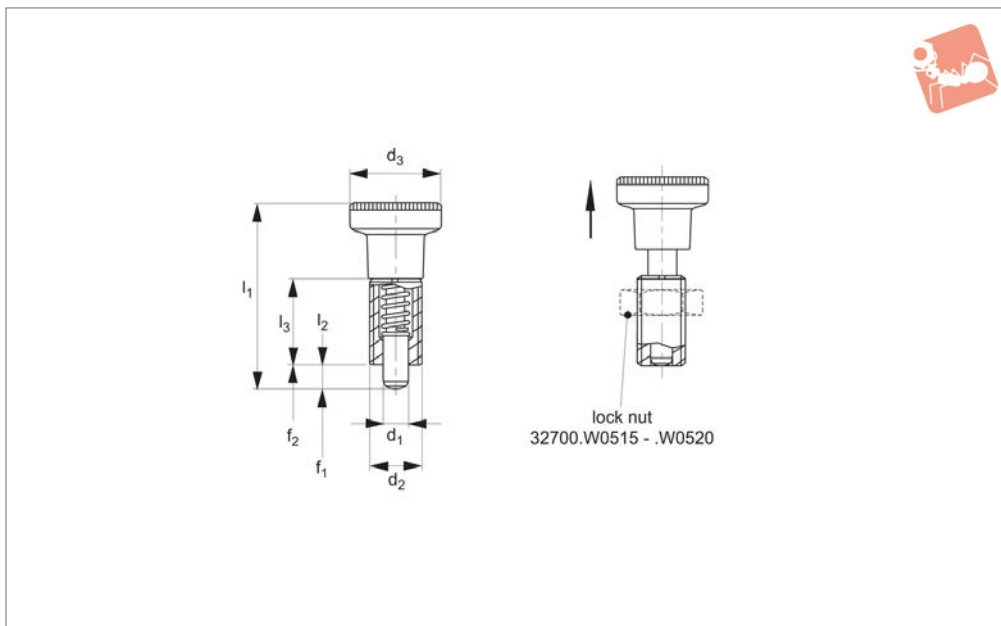

32742

INDEX PLUNGER & PINS

Material

All Stainless Steel Type-

Body: stainless steel 1.4305 (AISI 303).
 Locking pin: stainless steel 1.4305 (AISI 303), nickel plated.
 Grip: stainless steel 1.4305 (AISI 303).
 Spring: stainless steel 1.4310 (AISI 301).

Technical Notes

„Non Locking“ type- pin simply springs

back when pull ring released.
 Temperature resistance -30°C to +80°C
 Installation requires use of specific assembly tool, see part nos. 32740.W0955 to .W0960.

Lock nuts sold separately. See Products 65690 and 65692

Tips

Complete stainless steel construction designed with specific demands of food processing, pharmaceutical and water treatment industries in mind. Grip non-removable.
 Spring Load* = statistical average.

Order No.	Type	d_1 -0.02 -0.04	d_2	d_3	l_1 ≈	l_2 min.	l_3	Spring load F_1 N ≈	Spring load F_2 N ≈	Weight g
32742.W0705	Non Locking	5	M10x1,0	21	45.0	5	22	6.0	14	37.0
32742.W0706	Non Locking	6	M12x1,5	25	54.5	6	26	5.5	13	62.0
32742.W0707	Non Locking	8	M16x1,5	31	69.0	8	34	11.5	28	124.0
32742.W0710	Non Locking	10	M20x1,5	31	80.0	10	43	23.0	54	165.0



32600

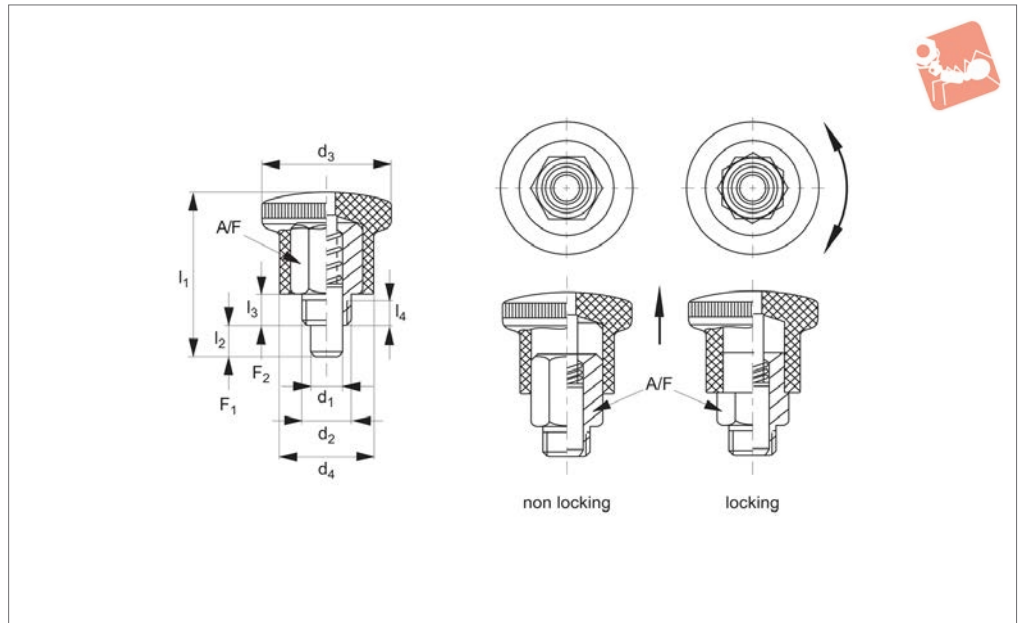

Material

Free cutting steel type-

Body: free cutting steel, galvanized.
Pin: stainless steel 1.4305 (AISI 303).
Grip: thermoplastic PA 6, black.

Stainless steel type-

Body: stainless steel 1.4305 (AISI 303).
Pin: stainless steel 1.4305 (AISI 303).
Grip: thermoplastic PA 6, black.

Technical Notes

„Locking“ type- enable pin to be held in

retracted/non-projecting position; pull back grip, turn 90° to engage ‚locking‘ on a notched catch.

„Non Locking“ type- pin simply springs back when grip released.

For positioning and indexing in the smallest of spaces. Particularly suited for use on sheet metal assemblies; e.g shopfitting displays, electrical cabinets and enclosures etc.

Extra fine thread

Temperature resistance from -30° to +80°C.

Distance collars no. 32750 can be used to adapt screw length.

Tips

Grip non-removable.
Spring loads * = statistical average.

Order No.	Material	Type	d ₁ 01-0.06	d ₂	d ₃	d ₄	l ₁	l ₂ min.	l ₃	l ₄ min.	A/F	Spring load F ₁ N ≈	Spring load F ₂ N ≈	Weight g
32600.W0024	Steel	Non Locking	4	M 8x0,75	21	15	26,5	5	5	3,5	10	4,5	12	14
32600.W0026	Steel	Non Locking	5	M 8x0,75	21	15	26,5	5	5	3,5	10	4,5	12	14
32600.W0028	Steel	Non Locking	6	M10x1,00	25	18	34,0	7	7	4,5	12	5,0	18	25
32600.W0030	Steel	Non Locking	7	M10x1,00	25	18	34,0	7	7	4,5	12	5,0	18	26
32600.W0034	Steel	Locking	4	M 8x0,75	21	15	26,5	5	5	3,5	10	4,5	12	13
32600.W0036	Steel	Locking	5	M 8x0,75	21	15	26,5	5	5	3,5	10	4,5	12	14
32600.W0038	Steel	Locking	6	M10x1,00	25	18	34,0	7	7	4,5	12	5,0	18	24
32600.W0040	Steel	Locking	7	M10x1,00	25	18	34,0	7	7	4,5	12	5,0	18	25
32600.W0224	Stainless	Non Locking	4	M 8x0,75	21	15	26,5	5	5	3,5	10	4,5	12	14
32600.W0226	Stainless	Non Locking	5	M 8x0,75	21	15	26,5	5	5	3,5	10	4,5	12	14
32600.W0228	Stainless	Non Locking	6	M10x1,00	25	18	34,0	7	7	4,5	12	5,0	18	25
32600.W0230	Stainless	Non Locking	7	M10x1,00	25	18	34,0	7	7	4,5	12	5,0	18	26
32600.W0234	Stainless	Locking	4	M 8x0,75	21	15	26,5	5	5	3,5	10	4,5	12	13
32600.W0236	Stainless	Locking	5	M 8x0,75	21	15	26,5	5	5	3,5	10	4,5	12	14
32600.W0238	Stainless	Locking	6	M10x1,00	25	18	34,0	7	7	4,5	12	5,0	18	24
32600.W0240	Stainless	Locking	7	M10x1,00	25	18	34,0	7	7	4,5	12	5,0	18	25



Index Plungers - Pull Grip

mini - for thin walled parts - extra fine thread

Index Plunger & Pins





32602

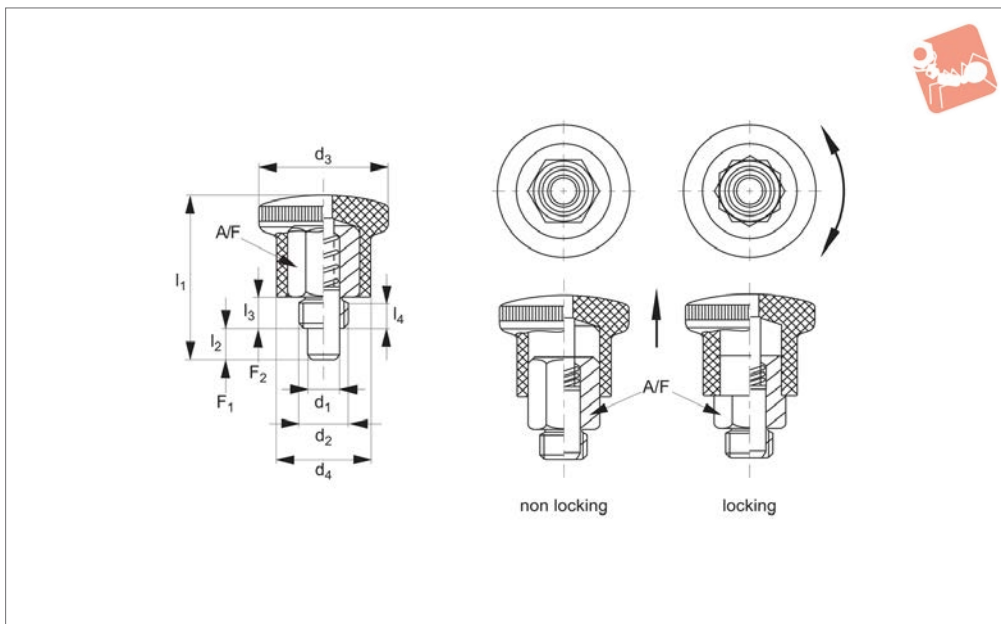

Material

Free cutting steel type-

Body: free cutting steel, galvanized.

Pin: stainless steel 1.4305 (AISI 303).

Grip: thermoplastic PA 6, black.

Stainless steel type-

Body: stainless steel 1.4305 (AISI 303).

Pin: stainless steel 1.4305 (AISI 303).

Grip: thermoplastic PA 6, black.

Technical Notes

„Locking“ type- enable pin to be held in

retracted/non-projecting position; pull back grip, turn 90° to engage ‚locking‘ on a notched catch.

„Non Locking“ type- pin simply springs back when grip released.

For positioning and indexing in the smallest of spaces. Particularly suited for use on sheet metal assemblies; e.g shopfitting displays, electrical cabinets and enclosures etc.

Temperature resistance from -30° to

+80°C.

Distance collars no. 32750 can be used to adapt screw length.

Fine Thread

Tips

Grip non-removable.

Spring loads * = statistical average.

Order No.	Material	Finish	d ₁	d ₂	d ₃	d ₄	l ₁	l ₂	l ₃	A/F	Spring load F ₁ N ≈	Spring load F ₂ N ≈	Weight g
32602.W0604	Steel	Non Locking	4	M 8x1,00	21	15	27.5	5	6	10	4	12	14
32602.W0608	Steel	Non Locking	5	M10x1,00	25	18	34.0	6	8	12	6	16	25
32602.W0612	Steel	Non Locking	6	M10x1,00	25	18	34.0	6	8	12	6	16	25
32602.W0616	Steel	Non Locking	6	M12x1,50	28	20	40.5	7	10	14	10	23	40
32602.W0620	Steel	Non Locking	7	M12x1,50	28	20	40.5	7	10	14	10	23	41
32602.W0624	Steel	Non Locking	8	M16x1,50	33	23	47.5	10	12	17	11	35	67
32602.W0628	Steel	Non Locking	10	M16x1,50	33	23	47.5	10	12	17	11	35	69
32602.W0632	Steel	Locking	4	M 8x1,00	21	15	27.5	5	6	10	4	12	13
32602.W0636	Steel	Locking	5	M10x1,00	25	18	34.0	6	8	12	6	16	23
32602.W0640	Steel	Locking	6	M10x1,00	25	18	34.0	6	8	12	6	16	25
32602.W0644	Steel	Locking	6	M12x1,50	28	20	40.5	7	10	14	10	23	39
32602.W0648	Steel	Locking	7	M12x1,50	28	20	40.5	7	10	14	10	23	39
32602.W0652	Steel	Locking	8	M16x1,50	33	23	47.5	10	12	17	11	35	65
32602.W0656	Steel	Locking	10	M16x1,50	33	23	47.5	10	12	17	11	35	67
32602.W0704	Stainless	Non Locking	4	M 8x1,00	21	15	27.5	5	6	10	4	12	14
32602.W0708	Stainless	Non Locking	5	M10x1,00	25	18	34.0	6	8	12	6	16	25
32602.W0712	Stainless	Non Locking	6	M10x1,00	25	18	34.0	6	8	12	6	16	25
32602.W0716	Stainless	Non Locking	6	M12x1,50	28	20	40.5	7	10	14	10	23	40
32602.W0720	Stainless	Non Locking	7	M12x1,50	28	20	40.5	7	10	14	10	23	41
32602.W0724	Stainless	Non Locking	8	M16x1,50	33	23	47.5	10	12	17	11	35	67
32602.W0728	Stainless	Non Locking	10	M16x1,50	33	23	47.5	10	12	17	11	35	69
32602.W0732	Stainless	Locking	4	M 8x1,00	21	15	27.5	5	6	10	4	12	13
32602.W0736	Stainless	Locking	5	M10x1,00	25	18	34.0	6	8	12	6	16	23
32602.W0740	Stainless	Locking	6	M10x1,00	25	18	34.0	6	8	12	6	16	25



Index Plungers - Pull Grip

mini - for thin walled parts - fine thread

Index Plunger & Pins



Order No.	Material	Finish	d ₁	d ₂	d ₃	d ₄	l ₁	l ₂	l ₃	A/F	Spring load F ₁ N ≈	Spring load F ₂ N ≈	Weight g
32602.W0744	Stainless	Locking	6	M12x1,50	28	20	40.5	7	10	14	10	23	39
32602.W0748	Stainless	Locking	7	M12x1,50	28	20	40.5	7	10	14	10	23	39
32602.W0752	Stainless	Locking	8	M16x1,50	33	23	47.5	10	12	17	11	35	65
32602.W0756	Stainless	Locking	10	M16x1,50	33	23	47.5	10	12	17	11	35	67



32604

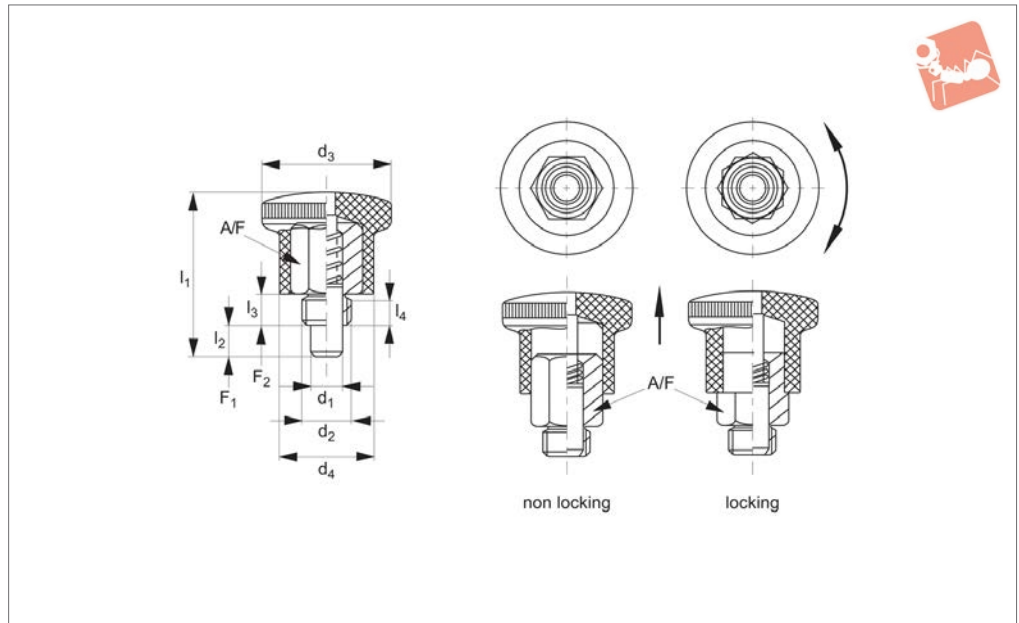

Material

Free cutting steel type-

Body: free cutting steel, galvanized.

Pin: stainless steel 1.4305 (AISI 303).

Grip: thermoplastic PA 6, black.

Stainless steel type-

Body: stainless steel 1.4305 (AISI 303).

Pin: stainless steel 1.4305 (AISI 303).

Grip: thermoplastic PA 6, black.

Technical Notes

„Locking“ type- enable pin to be held in

retracted/non-projecting position; pull back grip, turn 90° to engage ‚locking‘ on a notched catch.

„Non Locking“ type- pin simply springs back when grip released.

For positioning and indexing in the smallest of spaces. Particularly suited for use on sheet metal assemblies; e.g shopfitting displays, electrical cabinets and enclosures etc.

Temperature resistance from -30° to

+80°C.

Distance collars no. 32750 can be used to adapt screw length.

Coarse thread.

Tips

Grip non-removable.

Spring loads * = statistical average

Order No.	Material	Finish	d ₁	d ₂	d ₃	d ₄	l ₁	l ₂	l ₃	A/F	Spring load F ₁ N ≈	Spring load F ₂ N ≈	Weight g
32604.W0602	Steel	Non Locking	4	M 8x1,25	21	15	27.5	5	6	10	4	12	14
32604.W0606	Steel	Non Locking	5	M10x1,50	25	18	34.0	6	8	12	6	16	25
32604.W0610	Steel	Non Locking	6	M10x1,50	25	18	34.0	6	8	12	6	16	25
32604.W0614	Steel	Non Locking	6	M12x1,75	28	20	40.5	7	10	14	10	23	40
32604.W0618	Steel	Non Locking	7	M12x1,75	28	20	40.5	7	10	14	10	23	41
32604.W0622	Steel	Non Locking	8	M16x2,00	33	23	47.5	10	12	17	11	35	66
32604.W0626	Steel	Non Locking	10	M16x2,00	33	23	47.5	10	12	17	11	35	68
32604.W0630	Steel	Locking	4	M 8x1,25	21	15	27.5	5	6	10	4	12	13
32604.W0634	Steel	Locking	5	M10x1,50	23	18	34.0	6	8	12	6	16	23
32604.W0638	Steel	Locking	6	M10x1,50	25	18	34.0	6	8	12	6	16	24
32604.W0642	Steel	Locking	6	M12x1,75	28	20	40.5	7	10	14	10	23	38
32604.W0646	Steel	Locking	7	M12x1,75	28	20	40.5	7	10	14	10	23	39
32604.W0650	Steel	Locking	8	M16x2,00	33	23	47.5	10	12	17	11	35	64
32604.W0654	Steel	Locking	10	M16x2,00	33	23	47.5	10	12	17	11	35	66
32604.W0702	Stainless	Non Locking	4	M 8x1,25	21	15	27.5	5	6	10	4	12	14
32604.W0706	Stainless	Non Locking	5	M10x1,50	25	18	34.0	6	8	12	6	16	25
32604.W0710	Stainless	Non Locking	6	M10x1,50	25	18	34.0	6	8	12	6	16	25
32604.W0714	Stainless	Non Locking	6	M12x1,75	28	20	40.5	7	10	14	10	23	40
32604.W0718	Stainless	Non Locking	7	M12x1,75	28	20	40.5	7	10	14	10	23	41
32604.W0722	Stainless	Non Locking	8	M16x2,00	33	23	47.5	10	12	17	11	35	66
32604.W0726	Stainless	Non Locking	10	M16x2,00	33	23	47.5	10	12	17	11	35	68
32604.W0730	Stainless	Locking	4	M 8x1,25	21	15	27.5	5	6	10	4	12	13
32604.W0734	Stainless	Locking	5	M10x1,50	23	18	34.0	6	8	12	6	16	23
32604.W0738	Stainless	Locking	6	M10x1,50	25	18	34.0	6	8	12	6	16	24



Index Plungers - Pull Grip

mini - for thin walled parts - coarse thread

Index Plunger & Pins



Order No.	Material	Finish	d ₁	d ₂	d ₃	d ₄	l ₁	l ₂	l ₃	A/F	Spring load F ₁ N ≈	Spring load F ₂ N ≈	Weight g
32604.W0742	Stainless	Locking	6	M12x1,75	28	20	40.5	7	10	14	10	23	38
32604.W0746	Stainless	Locking	7	M12x1,75	28	20	40.5	7	10	14	10	23	39
32604.W0750	Stainless	Locking	8	M16x2,00	33	23	47.5	10	12	17	11	35	64
32604.W0754	Stainless	Locking	10	M16x2,00	33	23	47.5	10	12	17	11	35	66



32606

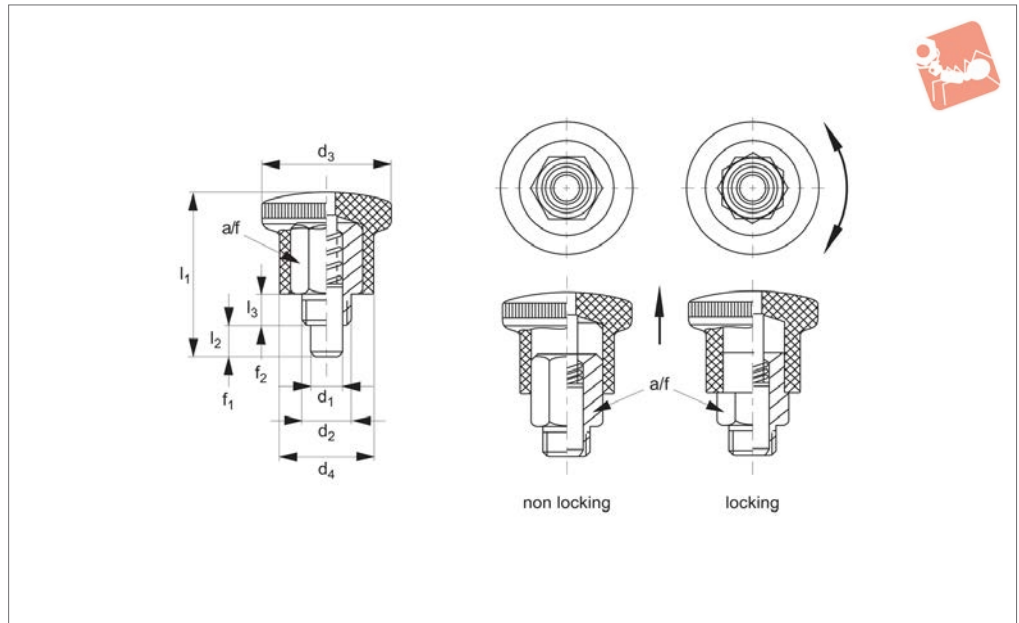

Material

Stainless steel type-

Body: stainless steel 1.4305 (AISI 303).
 Pin: stainless steel 1.4305 (AISI 303).
 Grip: stainless steel 1.4308 (AISI 304).

Technical Notes

„Locking“ type- enable pin to be held in retracted/non-projecting position; pull back grip, turn 90° to engage „locking“ on a

notched catch.

„Non Locking“ type- pin simply springs back when grip released.

For positioning and indexing in the smallest of spaces. Particularly suited for use on sheet metal assemblies; e.g shopfitting displays, electrical cabinets and enclosures etc.

Extra fine thread

Temperature resistance up to 250°C.
 Distance collars no. 32750 can be used to adapt screw length.

Tips

Grip non-removable.
 Spring loads * = statistical average.

Order No.	Type	d ₁ 0 -0.06	d ₂	d ₃	d ₄	l ₁	l ₂ min.	l ₃	A/F	Spring load F ₁ N ≈	Spring load F ₂ N ≈	Weight g
32606.W1102	Non-Locking	4	M 8	21	15	27.5	5	6	10	4	12	28
32606.W1104	Non-Locking	4	M 8x1	21	15	27.5	5	6	10	4	12	28
32606.W1106	Non-Locking	5	M10	25	18	34.0	6	8	12	6	16	49
32606.W1108	Non-Locking	5	M10x1	25	18	34.0	6	8	12	6	16	50
32606.W1110	Non-Locking	6	M10	25	18	34.0	6	8	12	6	16	50
32606.W1112	Non-Locking	6	M10x1	25	18	34.0	6	8	12	6	16	50
32606.W1114	Non-Locking	6	M12	28	20	40.5	7	10	14	10	23	74
32606.W1116	Non-Locking	6	M12x1,5	28	20	40.5	7	10	14	10	23	75
32606.W1118	Non-Locking	7	M12	28	20	40.5	7	10	14	10	23	75
32606.W1120	Non-Locking	7	M12x1,5	28	20	40.5	7	10	14	10	23	75
32606.W1122	Non-Locking	8	M16	33	23	47.5	10	12	17	11	34	110
32606.W1124	Non-Locking	8	M16x1,5	33	23	47.5	10	12	17	11	35	113
32606.W1126	Non-Locking	10	M16	33	23	47.5	10	12	17	11	35	113
32606.W1128	Non-Locking	10	M16x1,5	33	23	47.5	10	12	17	11	35	113
32606.W1130	Locking	4	M 8	21	15	27.5	5	6	10	4	12	28
32606.W1132	Locking	4	M 8x1	21	15	27.5	5	6	10	4	12	28
32606.W1134	Locking	5	M10	25	18	34.0	6	8	12	6	16	49
32606.W1136	Locking	5	M10x1	25	18	34.0	6	8	12	6	16	50
32606.W1138	Locking	6	M10	25	18	34.0	6	8	12	6	16	50
32606.W1140	Locking	6	M10x1	25	18	34.0	6	8	12	6	16	50
32606.W1142	Locking	6	M12	28	20	40.5	7	10	14	10	23	74
32606.W1144	Locking	6	M12x1,5	28	20	40.5	7	10	14	10	23	75
32606.W1146	Locking	7	M12	28	20	40.5	7	10	14	10	23	75
32606.W1148	Locking	7	M12x1,5	28	20	40.5	7	10	14	10	23	75
32606.W1150	Locking	8	M16	33	23	47.5	10	12	17	11	35	110
32606.W1152	Locking	8	M16x1,5	33	23	47.5	10	12	17	11	35	113
32606.W1154	Locking	10	M16	33	23	47.5	10	12	17	11	35	113



Index Plungers - Pull Grip

mini - for thin walled parts - extra fine thread

Index Plunger & Pins



Order No.	Type	d_1 0 -0.06	d_2	d_3	d_4	l_1	l_2 min.	l_3	A/F	Spring load F_1 N ≈	Spring load F_2 N ≈	Weight g
32606.W1156	Locking	10	M16x1,5	33	23	47.5	10	12	17	11	35	113



32730

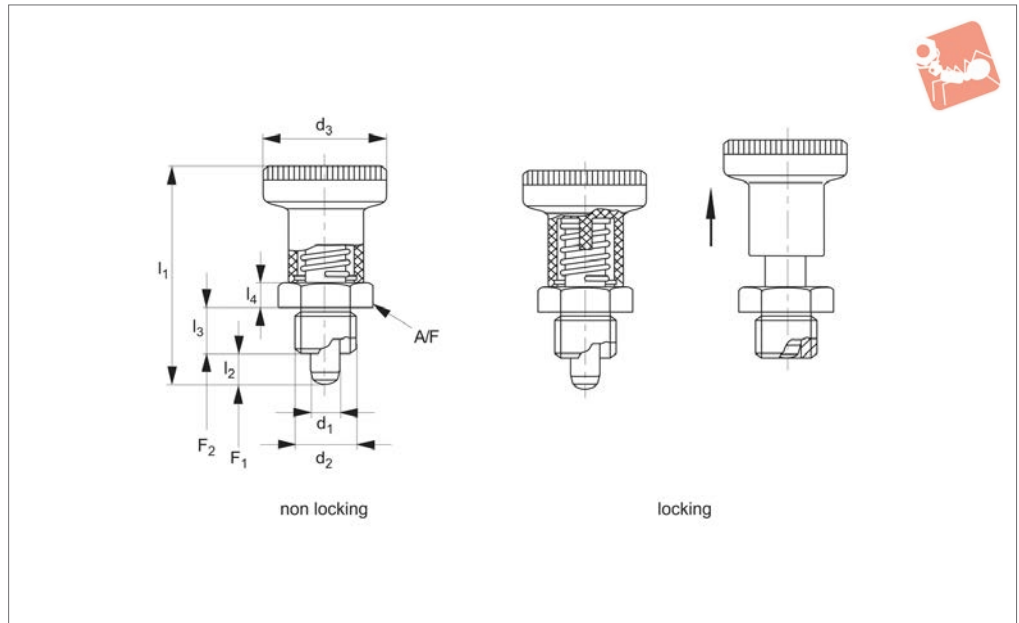

Material

Free Cutting Steel type-

Body: free cutting steel, blackened.

Pin: steel, hardened.

Grip: thermoplastic PA6, black.

Stainless steel type -

Body: stainless steel 1.4305 (AISI 303).

Pin: stainless steel 1.4305 (AISI 303), nickel plated.

Grip: thermoplastic PA6, black.

Technical Notes

„**Locking**” type- enable pin to be held in retracted/non-projecting position; pull back grip, turn 90° to engage ‚locking’ on a notched catch.

„**Non Locking**” type- pin simply springs back when grip released.
Short bodied index plungers for compact applications. Hexagon collar improves leverage for secure installation.

Temperature resistance from -30° to +80°C.

Lock nuts sold separately. See Products 65690 and 65692

Tips

Distance collars no. 32750 can be used to adapt screw length.

Spring loads * = statistical average.

Order No.	Material	Type	d ₁ -0.02 -0.04	d ₂	d ₃	l ₁ ≈	l ₂ min.	l ₃ -0.15	l ₄	A/F	Spring load F ₁ N ≈	Spring load F ₂ N ≈	Weight g
32730.W0226	Non Locking	Steel	6	M12x1,5	25	45	6	10	5	17	7	19	35.0
32730.W0228	Non Locking	Steel	8	M16x1,5	31	54	8	12	6	19	14	24	62.0
32730.W0236	Locking	Steel	6	M12x1,5	25	45	6	10	5	17	7	19	35.0
32730.W0238	Locking	Steel	8	M16x1,5	31	54	8	12	6	19	14	24	61.0
32730.W0246	Non Locking	Stainless	6	M12x1,5	25	45	6	10	5	17	7	19	35.0
32730.W0248	Non Locking	Stainless	8	M16x1,5	31	54	8	12	6	19	14	24	62.0
32730.W0256	Locking	Stainless	6	M12x1,5	25	45	6	10	5	17	7	19	35.0
32730.W0258	Locking	Stainless	8	M16x1,5	31	54	8	12	6	19	14	24	61.0



Index Plungers - Pull Grip

for thin walled parts

Index Plunger & Pins

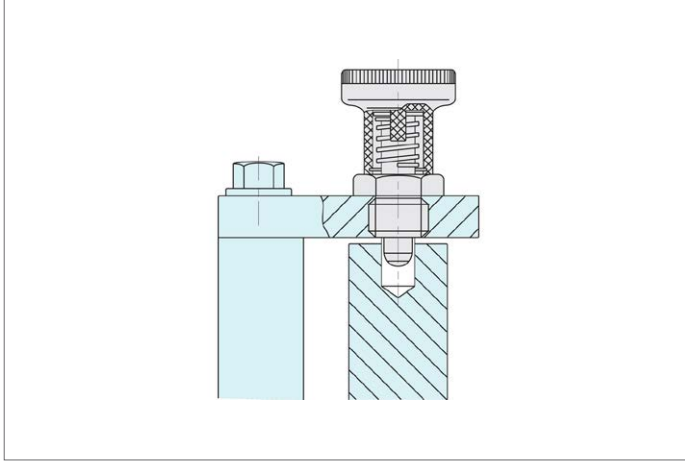

INDEX PLUNGER & PINS



32770

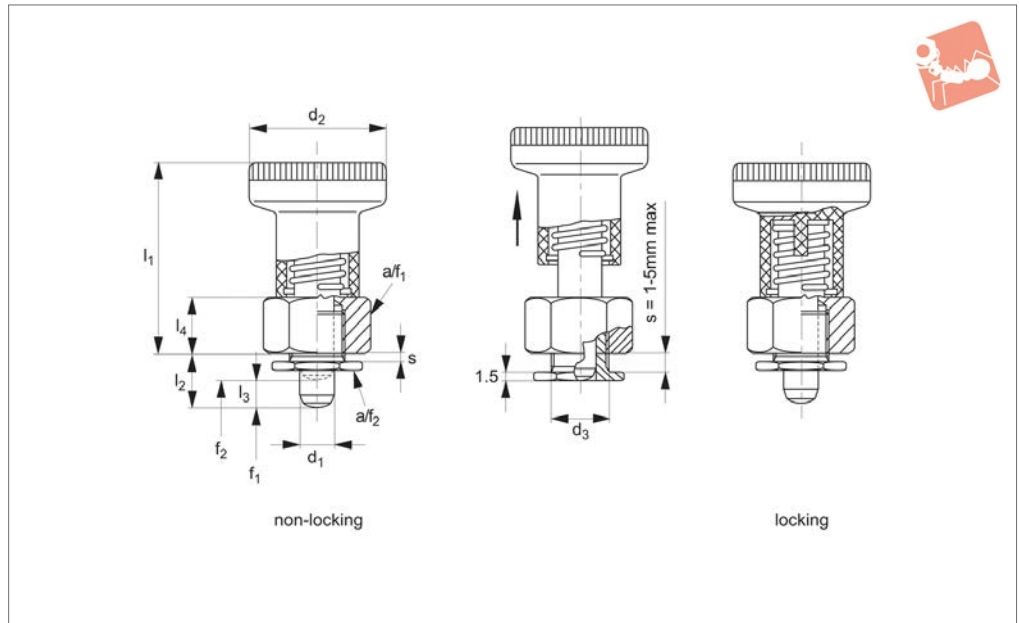

Material

Body: steel galvanised.
 Pin: stainless steel 1.4305, nickel plated.
 Grip: thermoplastic PA6, black.

Technical Notes

„Locking“ type- enable pin to be held in retracted position; pull back grip, turn 90°

to engage ‚locking‘ on a notched catch.
 „Non Locking“ type- pin simply springs back when grip released.

For installation on thin walled panels/ sheet metal of thickness 1 to 5mm.

Pin does not fully retract in all cases - protrusion of pin ,l₃‘ dependant upon

panel thickness of installation ,s‘

Temperature resistance -30°C to +80°C

Tips

Grip non-removable.
 Spring loads* = statistical average.

Order No.	Type	d ₁	d ₂	d ₃	l ₁	l ₂	l ₃	l ₄	s	Spring load F ₁ N	Spring load F ₂ N	A/F ₁	A/F ₂	Weight g
32770.W0266	Locking	6	25	10	34	8.5	6.0	10	1-5	8.5	22	17	14	39
32770.W0267	Locking	6	25	10	34	10.5	6.0	10	1-5	8.5	22	17	14	40
32770.W0268	Locking	8	31	12	40	10.0	7.5	12	1-5	15.5	28	19	16	63
32770.W0269	Locking	8	31	12	40	12.0	7.5	12	1-5	15.5	28	19	16	63
32770.W0286	Non Locking	6	25	10	34	8.5	6.0	10	1-5	8.5	22	17	14	39
32770.W0287	Non Locking	6	25	10	34	10.5	6.0	10	1-5	8.5	22	17	14	39
32770.W0288	Non Locking	8	31	12	40	10.0	7.5	12	1-5	15.5	28	19	16	61
32770.W0289	Non Locking	8	31	12	40	12.0	7.5	12	1-5	15.5	28	19	16	62
32770.W0299	Spanner = a/f2	-	-	-	-	-	-	-	-	-	-	-	-	27



Index Plungers - Pull Grip

flange mounting - extended pin

Index Plunger & Pins

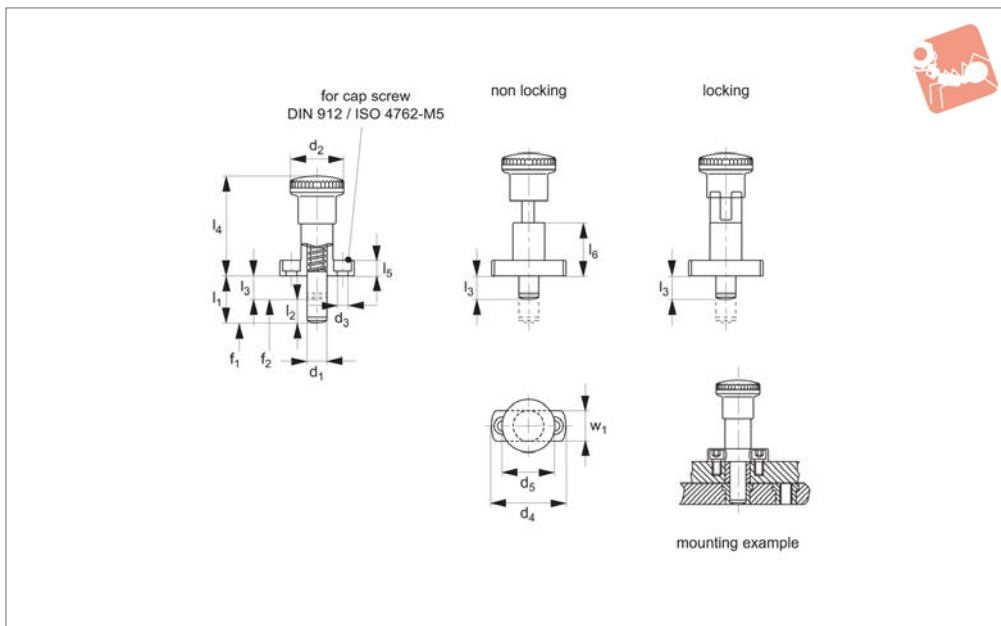

32530

INDEX PLUNGER & PINS

Material

Body: steel, blackened.
Pin: steel, hardened and ground.
Grip: thermoplastic PA6, black.

Technical Notes

„Locking“ type- enable pin to be held in retracted position; pull back grip, turn 90° to engage ‚locking‘ on a notched catch.
„Non Locking“ type- pin simply springs

back when grip is released.

Due to extended length pin does not fully retreat into plunger body when grip activated - note dimension l_3 for length pin remains exposed.

Extended pin assists locating and indexing of components. Due to its extended length the pin does not fully retract flush to the plunger body - please note dimensions l_1

for extended pin length and l_3 for retracted pin length. Pin is toleranced to h7 for improved location accuracy. Accuracy dependant upon suitable tolerance of bush, we suggest H7, with min. pin engagement to dim. l_3 .

Tips

Grip non-removable.
Spring Loads* = statistical average.

Order No.	Type	d_1 tol. h7	d_2	d_3	d_4	d_5	l_1	l_3	l_4	l_5	l_6	w_1	Spring load F_1 N ≈	Spring load F_2 N ≈	Stroke l_2	Weight g
32530.W0081	Non Locking	8	28	5,5	38	26	20	10	51	8	27	16	8,5	28	10	74
32530.W0083	Non Locking	8	28	5,5	38	26	26	16	51	8	27	16	8,5	28	10	77
32530.W0102	Non Locking	10	28	5,5	38	26	24	12	51	8	27	16	9,5	38	12	77
32530.W0104	Non Locking	10	28	5,5	38	26	32	20	51	8	27	16	9,5	38	12	80
32530.W0281	Locking	8	28	5,5	38	26	20	10	51	8	27	16	8,5	28	10	80
32530.W0283	Locking	8	28	5,5	38	26	26	16	51	8	27	16	8,5	28	10	83
32530.W0202	Locking	10	28	5,5	38	26	24	12	51	8	27	16	9,5	38	12	83
32530.W0204	Locking	10	28	5,5	38	26	32	20	51	8	27	16	9,5	38	12	100



32540

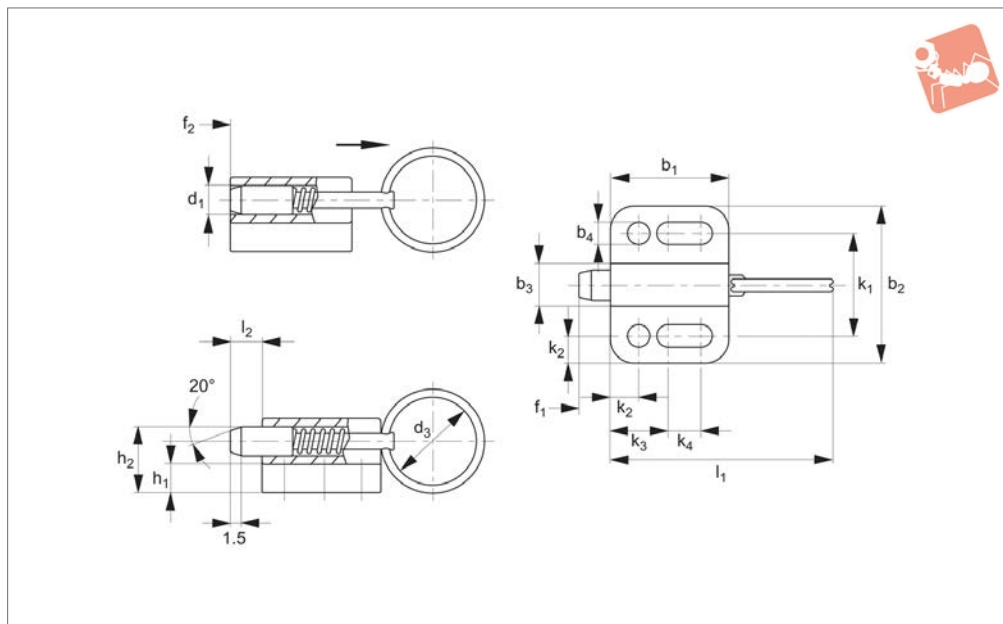

Material

Body: die cast zinc, black.

Pin: stainless steel 1.4305 (AISI 303).

Pull ring: stainless steel 1.4305 (AISI 303).

Integral mounting flange simplifies installation on flat surfaces.

Temperature resistant to 100°C.

Technical Notes

„Non Locking“ type- pin simply springs back when pull ring released.

Tips

Spring loads * = statistical average.

Order No.	Type	d ₁ tol. h9	d ₃	b ₁	b ₂	b ₃	b ₄ -0.2	h ₁	h ₂	k ₁ ±0.05	k ₂	k ₃	k ₄	l ₁	l ₂ min.	Spring load		Weight g
																F ₁ N ≈	F ₂ N ≈	
32540.W0304	Non Locking	4	14	16,5	22	6	3,3	4,0	7,0	14	4,0	8	4,5	34,5	4	3	12	10
32540.W0305	Non Locking	5	18	22,0	28	8	4,3	4,5	9,5	18	5,0	10	7,0	45,0	5	5	24	20
32540.W0306	Non Locking	6	24	27,5	32	10	5,4	5,0	10,5	21	5,5	12	10,0	57,5	6	5	21	40
32540.W0308	Non Locking	8	30	33,0	34	12	5,4	6,0	12,5	23	5,5	12	15,5	71,0	8	6	22	58
32540.W0310	Non Locking	10	30	35,0	39	14,5	6,5	6,0	14,5	27	6,0	15	13,5	75,0	10	4	25	83



Index Plungers - Pull Grip

flange mounting - locking

Index Plunger & Pins

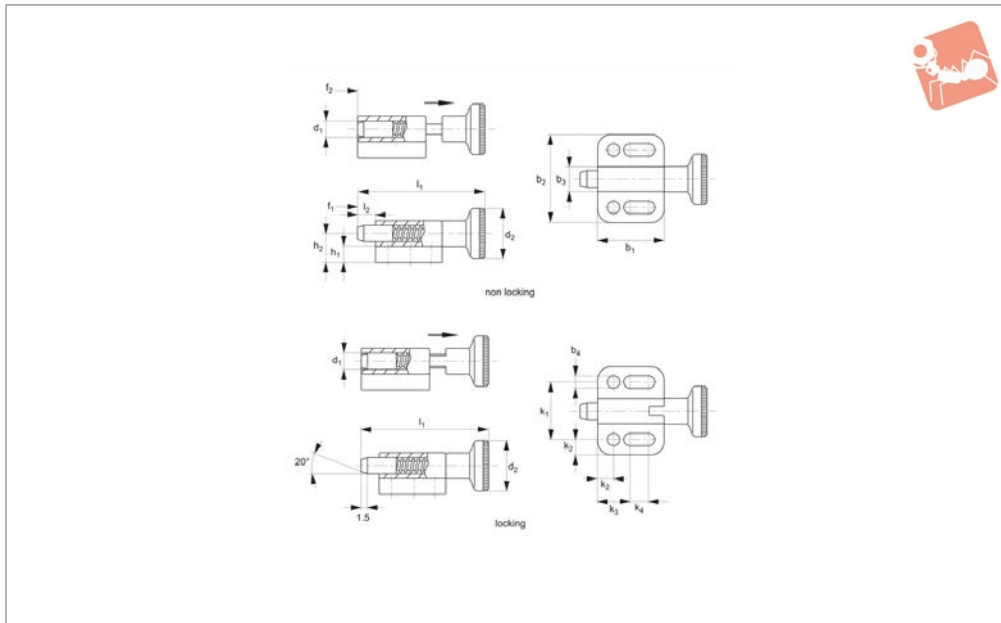

32542

INDEX PLUNGER & PINS

Material

Body: die cast zinc, black.
Pin: stainless steel 1.4305 (AIAI 303).
Grip: thermoplastic PA6, black.

back grip, turn 90° to engage 'locking' on a notched catch.
„Non Locking” type- pin simply springs back when grip released.

surfaces.
Temperature resistance from -30°C up to +80°C.

Technical Notes

„Locking” type- enable pin to be held in retracted/non-projecting position; pull

Integral mounting flange simplifies installation of index plunger on horizontal

Tips

Grip non-removable.
Spring loads * = statistical average.

Order No.	Type	d ₁ tol. h9	d ₂	b ₁	b ₂	b ₃	b ₄ -0.2	h ₁	h ₂	k ₁ ±0.05	k ₂	k ₃	k ₄	l ₁	l ₂ min.	Spring load		Weight g
																F ₁ N ≈	F ₂ N ≈	
32542.W0324	Non Locking	4	12	16,5	22	6	3,3	4,0	7,0	14	4,0	8	4,5	30,5	4	3	12	11
32542.W0325	Non Locking	5	16	22,0	28	8	4,3	4,5	9,5	18	5,0	10	7,0	40,0	5	5	24	20
32542.W0326	Non Locking	6	18	27,5	32	10	5,4	5,0	10,5	21	5,5	12	10,0	49,0	6	5	21	37
32542.W0328	Non Locking	8	21	33,0	34	12	5,4	6,0	12,5	23	5,5	12	15,5	59,0	8	6	22	61
32542.W0330	Non Locking	10	25	35,0	39	14,5	6,5	6,0	14,5	27	6,0	15	13,5	67,5	10	4	25	90
32542.W0344	Locking	4	12	19,0	22	6	3,3	4,0	7,0	14	4,0	8	7,0	33,0	4	3	12	10
32542.W0345	Locking	5	16	25,5	28	8	4,3	4,5	9,5	18	5,0	10	10,5	43,5	5	5	24	26
32542.W0346	Locking	6	18	30,5	32	10	5,4	5,0	10,5	21	5,5	12	13,0	52,0	6	5	21	40
32542.W0348	Locking	8	21	37,5	34	12	5,4	6,0	12,5	23	5,5	12	20,0	63,5	8	6	22	67
32542.W0350	Locking	10	25	40,0	39	14,5	27	6,0	14,5	27	6,0	15	18,5	72,5	10	4	25	98



32760

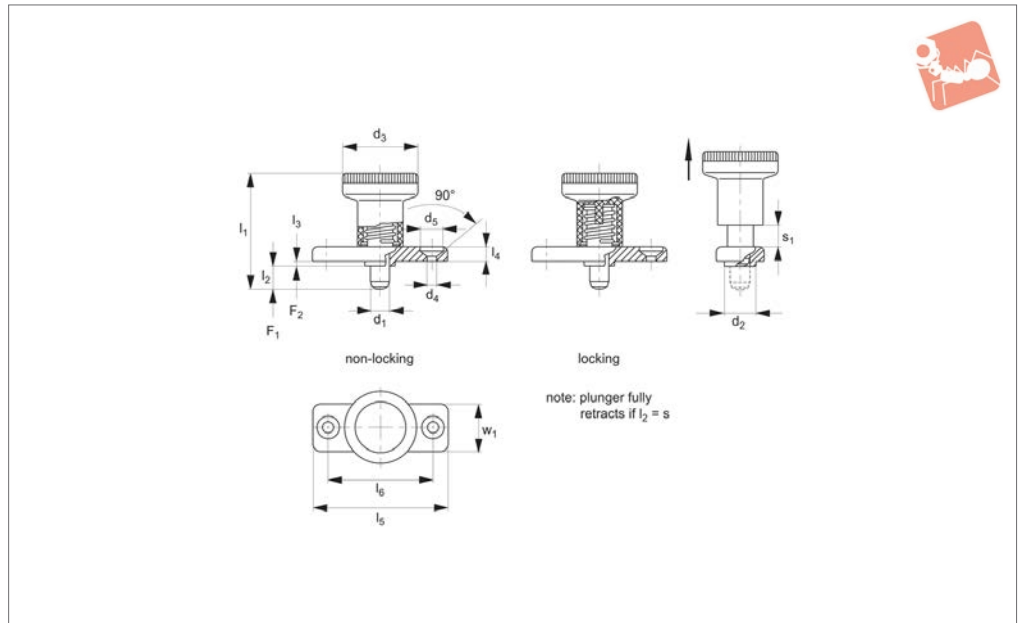

Material

Free Cutting Steel Type-

Body: die cast zinc, galvanised.

Pin: steel, hardened.

Grip: thermoplastic PA6, black

Stainless Steel Type-

Body: die-cast zinc, galvanised.

Pin: stainless steel, 1.4305 (AISI 303),

nickel plated.

Grip: thermoplastic PA6, black

Technical Notes

„**Locking**” type- enable pin to be held in retracted position; pull back grip, turn 90° to engage ‚locking’ on a notched catch.

„**Non Locking**” type- pin simply springs back when grip released.

Integral mounting flange simplifies installation on flat surfaces.

Pin does not fully retract in all cases - note dimension ‚s’ the stroke of the pin,

i.e. the amount by which the pin retracts when actuated.

Temperature resistance -30°C to +80°C

Tips

Grip non-removable.

Spring loads * = statistical average.

Order No.	Type	Material	d_1 -0.02 - 0.04	d_2 -0.02 - 0.1	d_3	d_4	d_5	l_1	l_2	l_3 -0.15	l_4	l_5	l_6	w_1	Spring load F_1 N ≈	Spring load F_2 N ≈	Stroke s_1	Weight g
32760.W0926	Non Locking	Steel	6	10	25	4,3	8,3	37	6	2,5	4,5	40	30	18	8,5	22	6	26
32760.W0927	Non Locking	Steel	6	10	25	4,3	8,3	45	14	2,5	4,5	40	30	18	8,5	22	6	38
32760.W0928	Non Locking	Steel	8	12	31	5,3	10,4	44	8	2,5	5,5	46	34	20	15,5	28	8	59
32760.W0929	Non Locking	Steel	8	12	31	5,3	10,4	54	18	2,5	5,5	46	34	20	15,5	28	8	63
32760.W0936	Locking	Steel	6	10	25	4,3	8,3	37	6	2,5	4,5	40	30	18	8,5	22	6	36
32760.W0937	Locking	Steel	6	10	25	4,3	8,3	45	14	2,5	4,5	40	30	18	8,5	22	6	38
32760.W0938	Locking	Steel	8	12	31	5,3	10,4	44	8	2,5	5,5	46	34	20	15,5	28	8	60
32760.W0939	Locking	Steel	8	12	31	5,3	10,4	54	18	2,5	5,5	46	34	20	15,5	28	8	63
32760.W0966	Non Locking	Stainless	6	10	25	4,3	8,3	37	6	2,5	4,5	40	30	18	8,5	22	6	26
32760.W0967	Non Locking	Stainless	6	10	25	4,3	8,3	45	14	2,5	4,5	40	30	18	8,5	22	6	38
32760.W0968	Non Locking	Stainless	8	12	31	5,3	10,4	44	8	2,5	5,5	46	34	20	15,5	28	8	59
32760.W0969	Non Locking	Stainless	8	12	31	5,3	10,4	54	18	2,5	5,5	46	34	20	15,5	28	8	63
32760.W0976	Locking	Stainless	6	10	25	4,3	8,3	37	6	2,5	4,5	40	30	18	8,5	22	6	36
32760.W0977	Locking	Stainless	6	10	25	4,3	8,3	45	14	2,5	4,5	40	30	18	8,5	22	6	38
32760.W0978	Locking	Stainless	8	12	31	5,3	10,4	44	8	2,5	5,5	46	34	20	15,5	28	8	60
32760.W0979	Locking	Stainless	8	12	31	5,3	10,4	54	18	2,5	5,5	46	34	20	15,5	28	8	63



Index Plunger - Pull Grip

flange mounting

Index Plunger & Pins



INDEX PLUNGER & PINS



32720

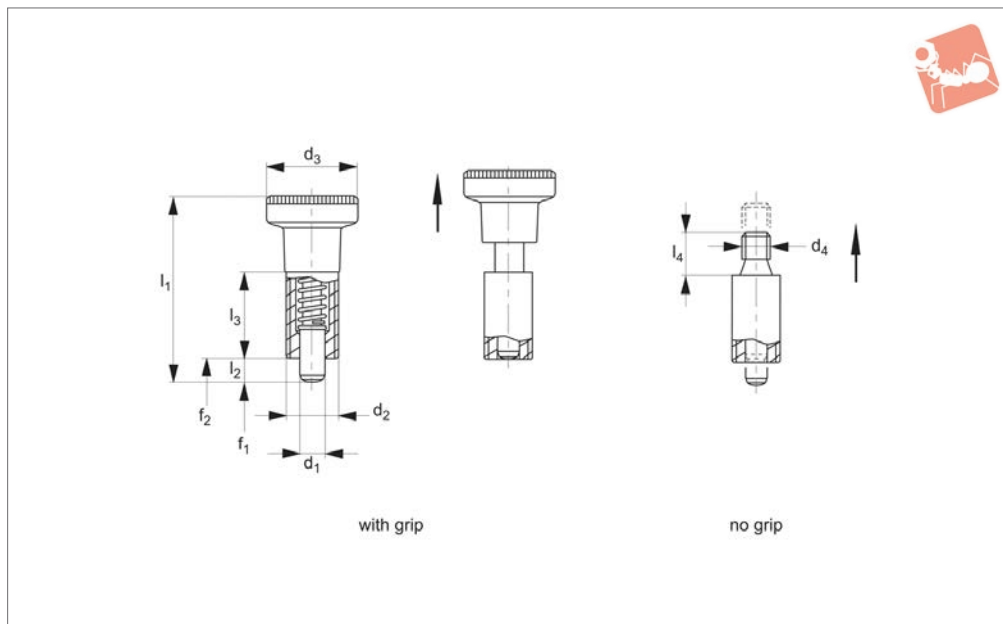

Material

Body: free cutting steel, blackened, weldable.

Pin: hardened steel.

Grip: plastic (PA 6), black, non-removable.

Technical Notes

„Non Locking“ type- pin simply springs

back when pull ring released.

Designed specifically for installation via welding or use of glues. Plungers without grip enable your own adaptation with actuation grip/lever to your own design. Without grip temperature resistance up to 250°C.

Tips

Grip non-removable.

Spring loads * = statistical average.

Order No.

32720.W0805

32720.W0806

32720.W0808

32720.W0825

32720.W0826

32720.W0828

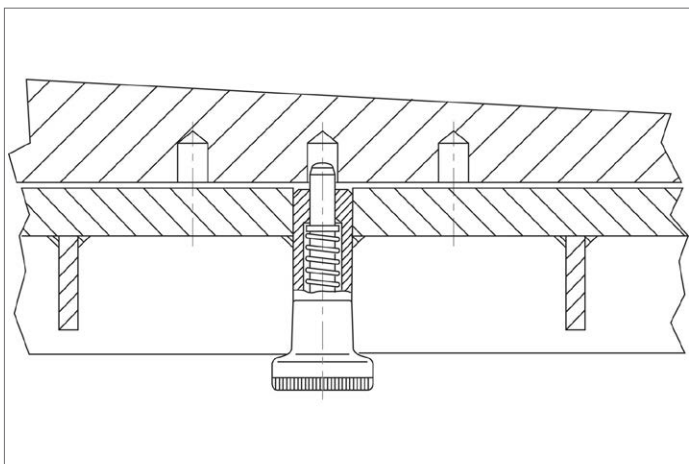



Index Plungers - Pull Grip

weldable - flange mounting - compact

Index Plunger & Pins

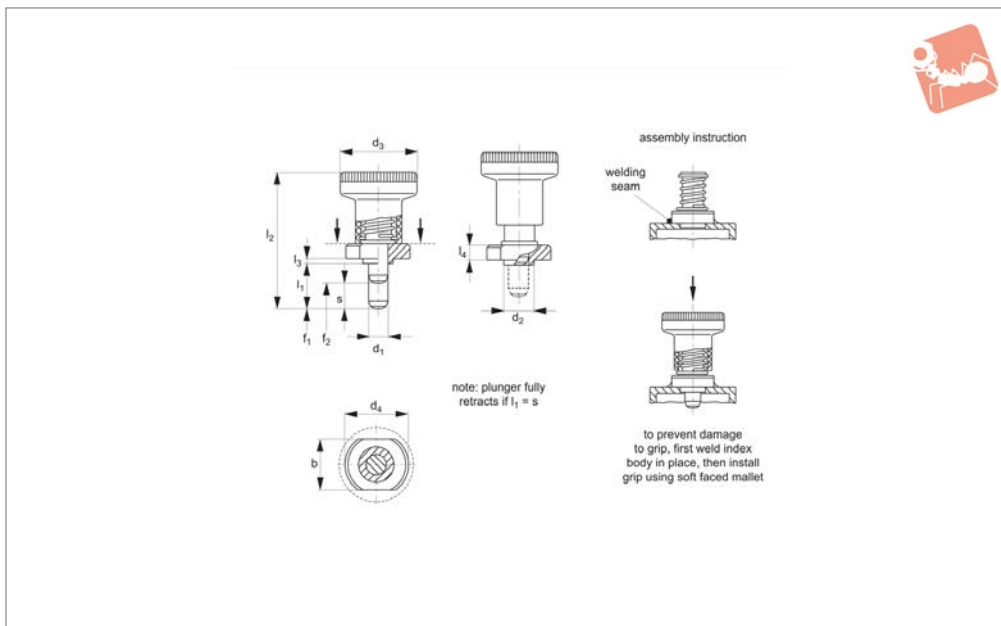

32762

INDEX PLUNGER & PINS

Material

Body: steel blackened.
 Locking Pin: hardened.
 Grip: black matte finish, not removable.

Technical Notes

„Locking“ type- enable pin to be held in retracted position; pull back grip, turn 90° to engage ‚locking‘ on a notched catch.

„Non Locking“ type- pin simply springs back when grip released.

Installation requires welding of plunger body to component. To avoid damage to plastic grip, item is supplied part assembled. Grip is driven in indexing mechanism with a light mallet. Non removable once installed.

Pin does not fully retract in all cases - note dimension ‚s‘ the stroke of the pin, i.e. the amount by which the pin retracts when actuated.

Temperature resistance -30°C to +80°C

Tips

Spring load* = statistical average.

Important Notes

Only parts 32762.W0826,W0828,W0836 and W0838 have fully retractable index bolt. Bolt of other parts do not fully retract into body, instead bolt will protrude by l_1-s when grip actuated.

Order No.	Type	d_1 -0.02 -0.1	l_1	b	d_2 -0.02 -0.04	d_3	Weight g
32762.W0826	Non Locking	6	6	18	10	25	35
32762.W0828	Non Locking	8	8	20	12	31	55
32762.W0829	Non Locking	8	18	20	12	31	60
32762.W0836	Locking	6	6	18	10	25	35
32762.W0839	Locking	8	18	20	12	31	60
32762.W0827	Non Locking	6	14	18	10	25	36
32762.W0837	Locking	6	14	18	10	25	36
32762.W0838	Locking	8	8	20	12	31	55

Order No.	d_4	l_2	l_3	l_4	s	Spring load F_1 N ≈	Spring load F_2 N ≈	Axial load N
32762.W0826	22	37	1.5	5.5	6	8.5	22	400
32762.W0828	25	44	2.0	6.5	8	15.5	28	500
32762.W0829	25	44	2.0	6.5	8	15.5	28	500
32762.W0836	22	37	1.5	5.5	6	8.5	22	400
32762.W0839	25	44	2.0	6.5	8	15.5	28	500
32762.W0827	22	37	1.5	5.5	6	8.5	22	400
32762.W0837	22	37	1.5	5.5	6	8.5	22	400
32762.W0838	25	44	2.0	6.5	8	15.5	28	500



32781

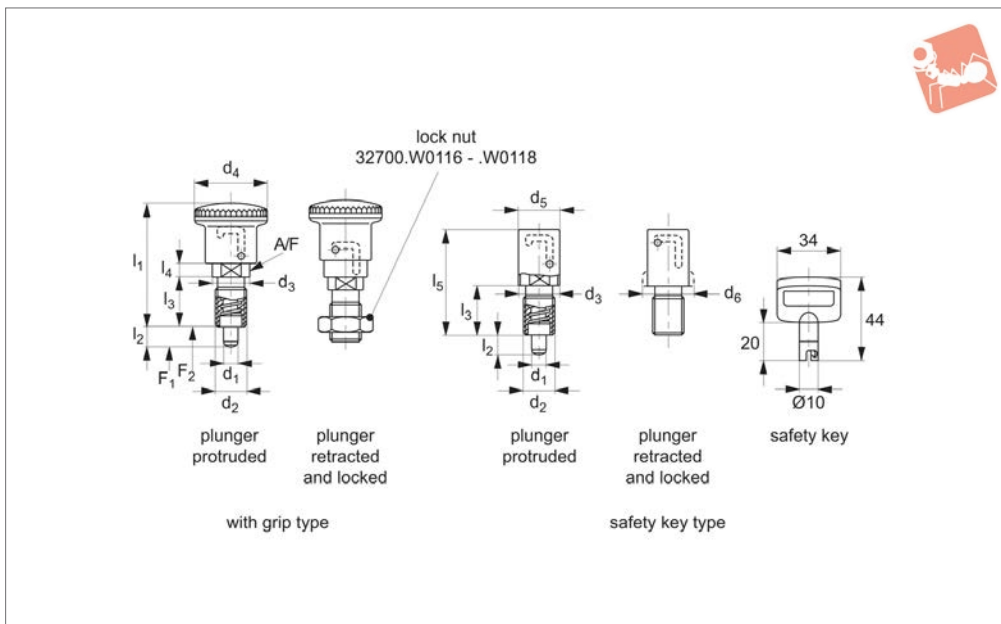

Material

Body: free cutting steel, zinc plated, blue passivated.

Pin: stainless steel, 1.4305 (AISI 303).

Spring: stainless steel, 1.4310 (AISI 301).

Grip: thermoplastic PA6, black.

Technical Notes

Tamper resistant against unauthorised or accidental actuation.

At start position pin is protruding, when lever is actuated pin retracts.

Two different types available;

with grip - enables pin to be held in retracted/non projecting position; pull back grip, turn 90° to engage ,locking' via a deep notch in plunger body.

with safety key - use key to hold pin in retracted/non-projecting position; acuate

key (please order seperately) turn 90° to engage ,locking via a deep notch in plunger body.

Lock nuts sold separately See products 65690 and 65692

Tips

Grip non-removable.

Spring loads* = statistical average.

Order No.	Type	d ₁ 0 -0.05	d ₂	d ₃	d ₄	d ₅	d ₆	l ₁ ≈	l ₂	l ₃	l ₄ ≈	l ₅	A/F	Spring load N ≈	F ₁	Spring load N ≈	F ₂	Weight kg
32781.W0006	With Grip	6	M12x1,5	16	28	17		50	8	20	6	43	14	13		28		0,05
32781.W0008	With Grip	8	M16x1,5	18	28	17	20	52	10	22	6	48	16	14		38		0,05
32781.W0026	For Safety key	6	M12x1,5	16	28	17		50	8	20	6	43	14	13		28		0,03
32781.W0028	For Safety key	8	M16x1,5	18	28	17	20	52	10	22	6	48	16	14		38		0,05
32781.W0998	Safety key																	

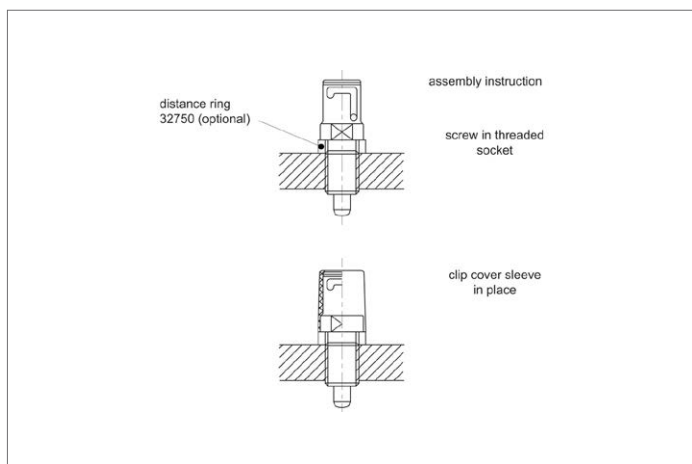



Index plungers - Pull Grip

locking - tamper resistant - pin retracted at start

Index Plunger & Pins

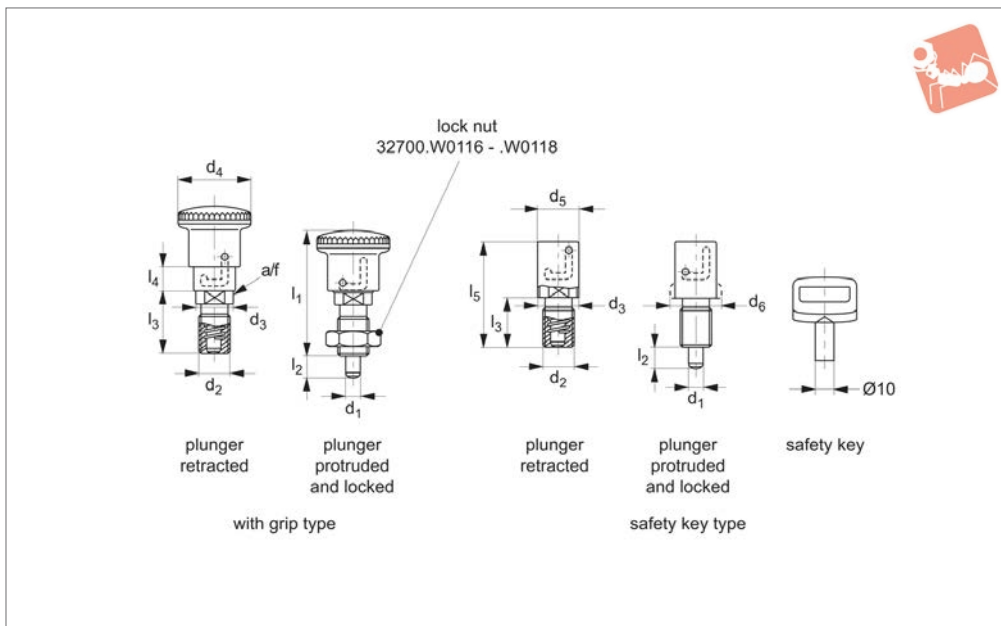

32782

INDEX PLUNGER & PINS

Material

Body: free cutting steel, zinc plated, blue passivated.
 Pin: stainless steel, 1.4305 (AISI 303).
 Spring: stainless steel, 1.4301 (AISI301).
 Grip: thermoplastic PA6, black.

Technical Notes

Tamper resistant against unauthorised or accidental actuation.

At start position pin is retracted, when lever is actuated pin protrudes.

Two different types available;
with grip - use key to hold pin in protruding position; pull back grip, turn 90° to engage ,locking' via a deep notch in plunger body.

with safety key - use key to hold pin in

protruding position; acuate key (please order seperately) turn 90° to engage ,locking' via a deep notch in plunger body.

Lock nuts sold separately See products 65690 and 65692

Tips

Grip non-removable.
 Spring loads* = statistical average.

Order No.	Type	d ₁ 0 -0.05	d ₂	d ₃	d ₄	d ₅	Weight kg
32782.W0356	With Grip	6	M12x1,5	16	28	17	0.05
32782.W0358	With Grip	8	M16x1,5	18	28	17	0.05
32782.W0366	For Safety Key	6	M12x1,5	16	28	17	0.05
32782.W0368	For Safety Key	8	M16x1,5	18	28	17	0.05
32782.W0999	Key	-	-	-	-	-	-

Order No.	d ₆	l ₁ ≈	l ₂	l ₃	l ₄ ≈	l ₅	A/F	Spring load F ₁ N ≈	Spring load F ₂ N ≈
32782.W0356	-	51.5	8	20	6	43	14	12	27
32782.W0358	20	54.5	10	22	6	48	16	12	35
32782.W0366	-	51.5	8	20	6	43	14	12	27
32782.W0368	20	54.5	10	22	6	48	16	12	35
32782.W0999	-	-	-	-	-	-	-	-	-

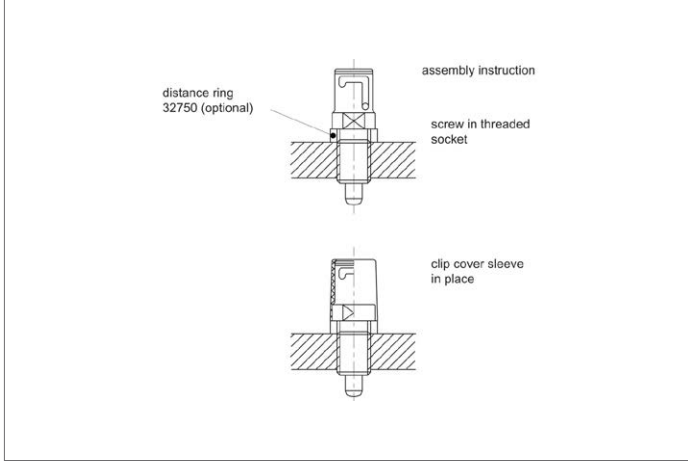



Index Plungers - T-handle Grip

compact - non locking

Index Plunger & Pins

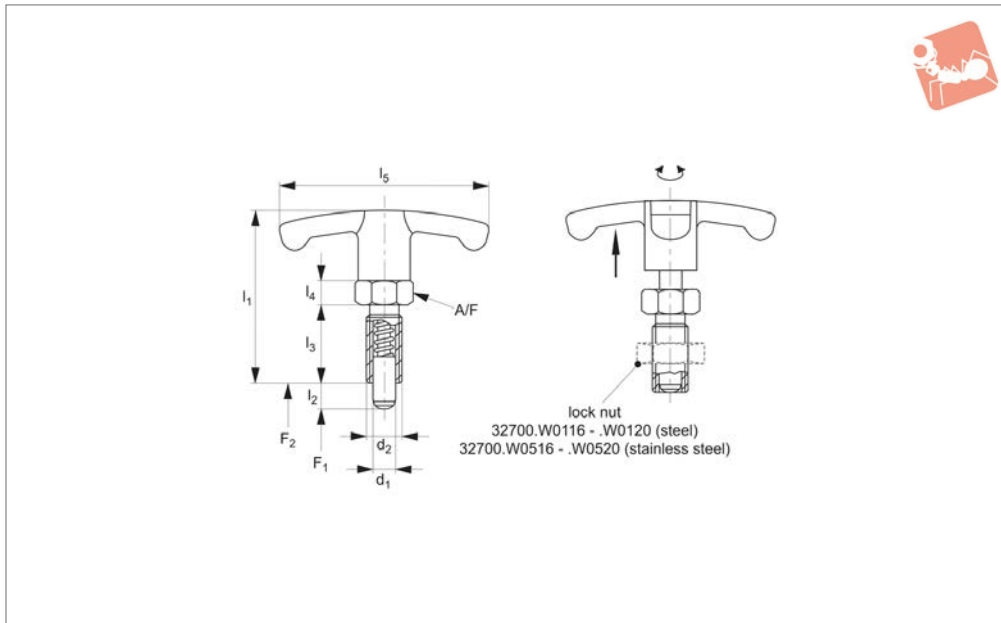

32502

INDEX PLUNGER & PINS

Material

Free cutting Steel Type-

Body: Free cutting steel, blackened.
Pin: Steel, hardened.
Grip: Thermoplastic PA6, black, dull.

Stainless Steel Type-

Body: Stainless steel 1.4305 (AISI 303).
Pin: Stainless steel 1.4305 (AISI 303), nickel plated.
Grip: Thermoplastic PA6, black, dull.

Technical Notes

T-handle grip makes for improved hand-

ling, especially when operator is using safety gloves etc.

Thread recess on body allows full engagement of thread length. Hexagon collar improves leverage for secure installation.

„Non Locking“ type- pin simply springs back when grip released.

Lock nuts sold separately. See products 65690 and 65692

Tips

Distance collar no. 32750 can be used to adapt screw length.

Grip non-removable.

Spring loads* = statistical average.

Order No.	Type	Material	d ₁ -0.02 -0.04	l ₂	d ₂	l ₁	l ₃	l ₄	l ₅	A/F	Spring load N F ₁	Spring load N F ₂	Weight g
32502.W0820	Non Locking	Steel	6	6	M12x1,5	48	22	6	54	14	6,5	19	31,0
32502.W0822	Non Locking	Steel	6	9	M12x1,5	48	22	6	54	14	6,0	25	32,0
32502.W0824	Non Locking	Steel	8	8	M16x1,5	59	26	8	59	17	8,5	26	64,0
32502.W0826	Non Locking	Steel	8	12	M16x1,5	59	26	8	59	17	8,5	28	65,0
32502.W0828	Non Locking	Steel	10	12	M16x1,5	59	26	8	59	17	9,5	38	66,0
32502.W0830	Non Locking	Steel	12	15	M20x1,5	68	33	10	59	22	11,5	40	120,0
32502.W0920	Non Locking	Stainless steel	6	6	M12x1,5	48	22	6	54	14	6,5	19	31,0
32502.W0922	Non Locking	Stainless steel	6	9	M12x1,5	48	22	6	54	14	6,0	25	32,0
32502.W0924	Non Locking	Stainless steel	8	8	M16x1,5	59	26	8	59	17	8,5	26	64,0
32502.W0926	Non Locking	Stainless steel	8	12	M16x1,5	59	26	8	59	17	8,5	28	65,0
32502.W0928	Non Locking	Stainless steel	10	12	M16x1,5	59	26	8	59	17	9,5	38	66,0
32502.W0930	Non Locking	Stainless steel	12	15	M20x1,5	68	33	10	59	22	11,5	40	120,0



32504

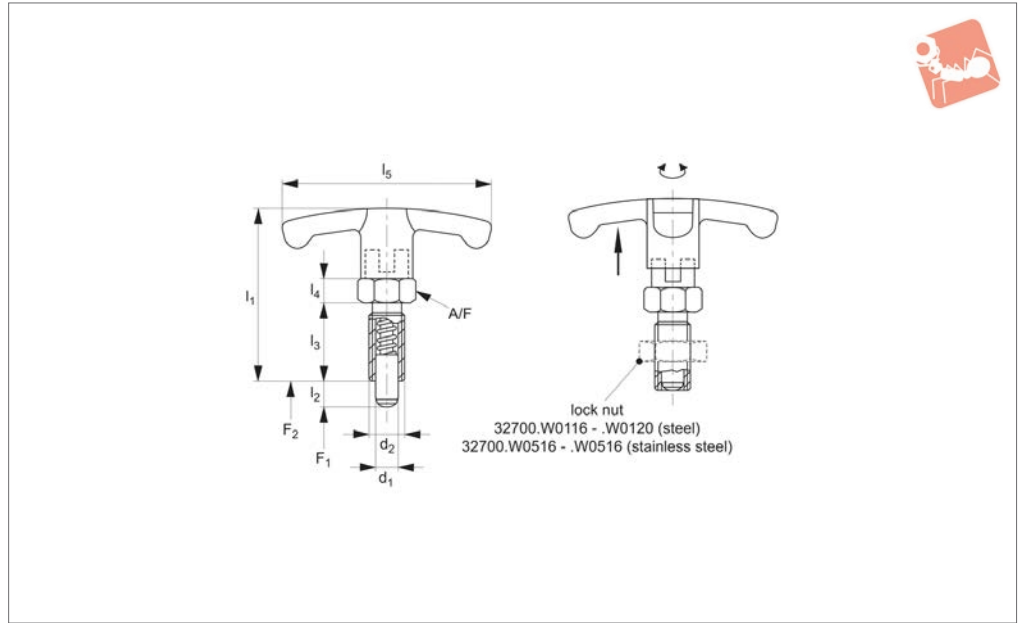

Material

Free cutting Steel Type-

Body: free cutting steel, blackened.

Pin: steel, hardened.

Grip: thermoplastic PA6, black, dull.

Stainless Steel Type-

Body: stainless steel 1.4305 (AISI 303).

Pin: stainless steel 1.4305 (AISI 303), nickel plated.

Grip: thermoplastic PA6, black, dull.

Technical Notes

T-handle grip makes for improved hand-

ling, especially when operator is using safety gloves etc.

Thread recess on body allows full engagement of thread length. Hexagon collar improves leverage for secure installation.

„Locking“ type- enable pin to be held in retracted/non-projecting position; pull back grip, turn 90° to engage ‚locking‘ on a notched catch.

Lock nuts sold separately. See products 65690 and 65692

Tips

Distance collars no. 32750 can be used to adapt screw length.

Grip non-removable.

Spring loads* = statistical average.

Order No.	Type	Material	d ₁	l ₂	d ₂	l ₁	l ₃	l ₄	l ₅	A/F	Spring load F ₁ N ≈	Spring load F ₂ N ≈	Weight g
32504.W0832	Locking	Steel	6	6	M12x1,5	48	22	6	54	14	6.5	19	33.0
32504.W0834	Locking	Steel	6	9	M12x1,5	48	22	6	54	14	6.0	25	34.0
32504.W0836	Locking	Steel	8	8	M16x1,5	59	26	8	59	17	8.5	26	68.0
32504.W0838	Locking	Steel	8	12	M16x1,5	59	26	8	59	17	8.5	28	71.0
32504.W0840	Locking	Steel	10	12	M16x1,5	59	26	8	59	17	9.5	38	72.0
32504.W0842	Locking	Steel	12	15	M20x1,5	68	33	10	59	22	11.5	40	127.0
32504.W0932	Locking	Stainless	6	6	M12x1,5	48	22	6	54	14	6.5	19	33.0
32504.W0934	Locking	Stainless	6	9	M12x1,5	48	22	6	54	14	6.0	25	34.0
32504.W0936	Locking	Stainless	8	8	M16x1,5	59	26	8	59	17	8.5	26	68.0
32504.W0938	Locking	Stainless	8	12	M16x1,5	59	26	8	59	17	8.5	28	71.0
32504.W0940	Locking	Stainless	10	12	M16x1,5	59	26	8	59	17	9.5	38	72.0
32504.W0942	Locking	Stainless	12	15	M20x1,5	68	33	10	59	22	11.5	40	127.0



Index Plungers - Lever Grip

pin protruding at start

Index Plunger & Pins

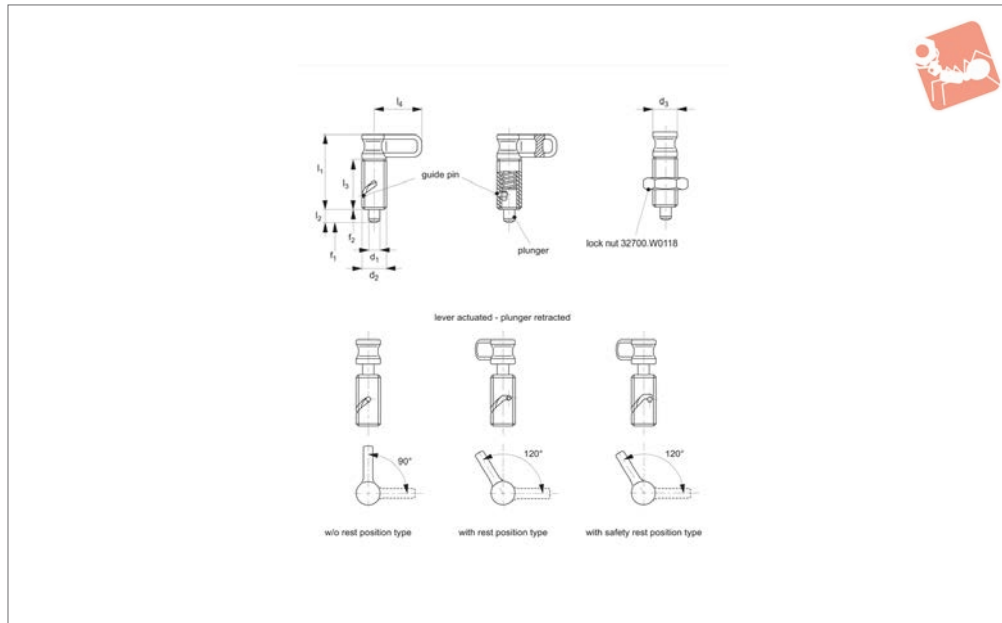

32491

INDEX PLUNGER & PINS

Material

Body: steel zinc plated, blue passivated.
Pin: stainless steel 1.4305 (AISI 303).
Grip/Lever: thermoplastic, black.

Technical Notes

At start position locking pin is protruding, when lever is actuated locking pin retracts.

The lever can be turned anti-clockwise by 90° or 120°, over a cam guide, to retract

the pin.

Three different types available;

1) without rest position- sprung loaded pin which springs back to start position whenever released.

2) with rest position- pin held in retracted position via indexed notch on cam.

3) with safety rest position- pin held in retracted position via deep notch, to avoid

accidental actuation, lever must first be pulled out of notch prior to release.

Lock nuts sold separately. See products 65690 and 65692

Tips

Spring Loads* = statistical average.

Order No.	Type	d ₁	d ₂	d ₃	l ₁ ≈	l ₂	l ₃ min.	l ₄	Spring load F ₁ N ≈	Spring load F ₂ N ≈
32491.W0006	W/o Rest Position - Spring Back	6	M16x1,5	16	51	8	35	32	6.5	20
32491.W0007	W/o Rest Position - Spring Back	8	M16x1,5	16	51	8	35	32	6.5	20
32491.W0009	W/o Rest Position - Spring Back	10	M16x1,5	16	51	8	35	32	6.5	20
32491.W0356	With Rest Position	6	M16x1,5	16	51	8	35	32	6.5	20
32491.W0357	With Rest Position	8	M16x1,5	16	51	8	35	32	6.5	20
32491.W0359	With Rest Position	10	M16x1,5	16	51	8	35	32	6.5	20
32491.W0456	With Safety Rest Position	6	M16x1,5	16	51	8	35	32	6.5	20
32491.W0457	With Safety Rest Position	8	M16x1,5	16	51	8	35	32	6.5	20
32491.W0459	With Safety Rest Position	10	M16x1,5	16	51	8	35	32	6.5	20



32492

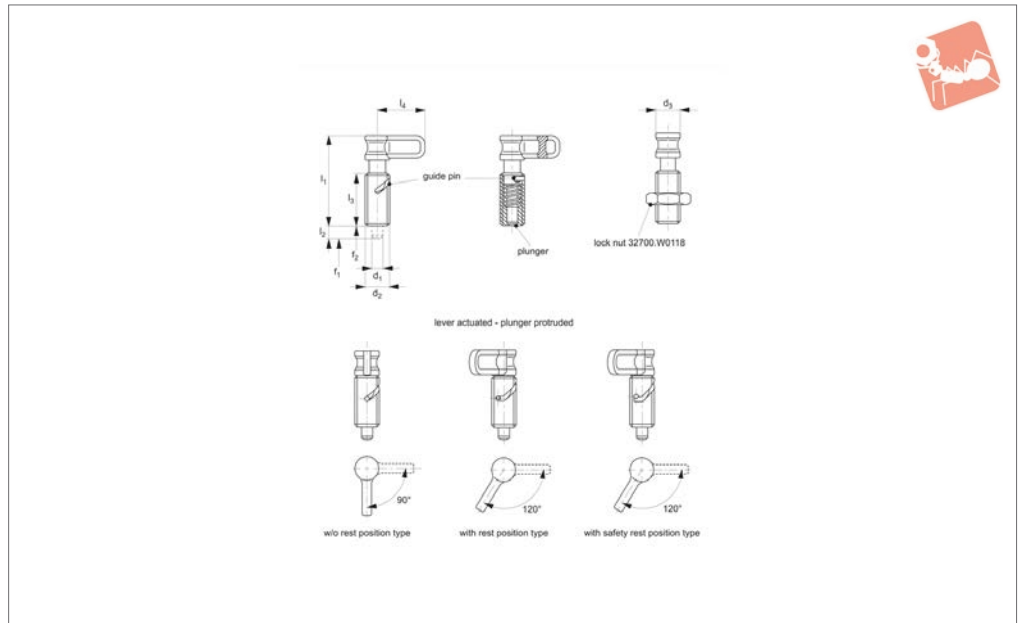

Material

Body: steel, zinc plated, blue passivated.
 Pin: stainless steel, 1.4305 (AISI 303).
 Grip/Lever: thermoplastic, black.

Technical Notes

At start position locking pin is retracted, when lever is actuated locking pin protrudes.

The lever can be turned anti-clockwise by

90° or 120°, over a cam guide, to extend the pin.

Three different types available;

1) without rest position- sprung loaded pin which springs back to start position whenever released.

2) with rest position- pin held in protruding position via indexed notch on cam,

3) with safety rest position- pin held in

protruding position via deep notch, to avoid accidental actuation, lever must first be pulled out of notch prior to release.

Lock nuts sold separately. See products 65690 and 65692

Tips

Spring Loads* = statistical average.

Order No.	Type	d ₁	d ₂	d ₃	l ₁ ≈	l ₂	l ₃ min.	l ₄	Spring load F ₁ N ≈	Spring load F ₂ N ≈
32492.W0326	W/o Rest Position - Spring Back	6	M16x1,5	16	60	8	35	32	7	16.5
32492.W0327	W/o Rest Position - Spring Back	8	M16x1,5	16	60	8	35	32	7	16.5
32492.W0366	With Rest Position	6	M16x1,5	16	60	8	35	32	7	16.5
32492.W0367	With Rest Position	8	M16x1,5	16	60	8	35	32	7	16.5
32492.W0466	With Safety Rest Position	6	M16x1,5	16	60	6	35	32	7	16.5
32492.W0467	With Safety Rest Position	8	M16x1,5	16	60	6	35	32	7	16.5



Index Plungers - Lever Grip

locking - steel

Index Plunger & Pins

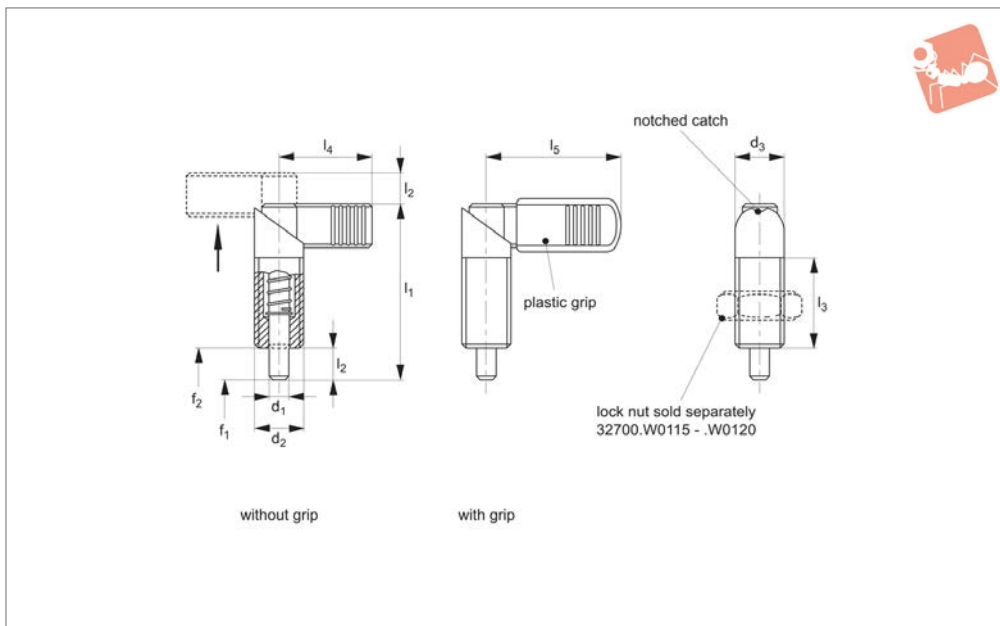

32500

INDEX PLUNGER & PINS

Material

Body: free-cutting steel, blackened.

Pin: hardened steel.

Plastic grip: thermoplastic, black, dull.

Technical Notes

Turn lever 180° to retract pin. To enable

pin to be held in retracted position, secure lever in notched catch on plunger body.

Plastic grip type, improves handling.

Temperature resistance of type with plastic grip is -30°C to +80°C

Lock nuts sold separately. See products 65690 and 65692

Tips

Spring loads * = statistical average.

Order No.	Type	d_1 -0.02 -0.04	d_2	d_3	l_1 ≈	l_2 min.	l_3 +1.5	l_4	l_5	Spring load F_1 N ≈	Spring load F_2 N	Weight g
32500.W0000	Without Grip	4	M10x1,0	10	37.5	6	19	21	-	8.5	25.0	17.0
32500.W0001	Without Grip	5	M10x1,0	10	37.5	6	19	21	-	8.5	25.0	18.0
32500.W0002	Without Grip	6	M10x1,0	10	37.5	6	19	21	-	8.5	25.0	18.0
32500.W0003	Without Grip	5	M12x1,5	12	47.0	8	26	26	-	8.5	19.5	29.0
32500.W0004	Without Grip	6	M12x1,5	12	47.0	8	26	26	-	8.5	19.5	29.0
32500.W0006	Without Grip	6	M16x1,5	16	56.0	10	30	32	-	11.5	30.5	59.0
32500.W0005	Without Grip	8	M12x1,5	12	47.0	8	26	26	-	8.5	19.5	30.0
32500.W0007	Without Grip	8	M16x1,5	16	56.0	10	30	32	-	11.5	30.5	61.0
32500.W0008	Without Grip	8	M20x1,5	20	69.0	12	36	37	-	21.0	57.5	121.0
32500.W0009	Without Grip	10	M16x1,5	16	56.0	10	30	32	-	11.5	30.5	64.0
32500.W0010	Without Grip	10	M20x1,5	20	69.0	12	36	37	-	21.0	57.5	123.0
32500.W0012	Without Grip	12	M20x1,5	20	69.0	12	36	37	-	21.0	57.5	127.0
32500.W0353	With Grip	5	M12x1,5	12	47.0	8	26	-	32	8.5	19.5	30.0
32500.W0354	With Grip	6	M12x1,5	12	47.0	8	26	-	32	8.5	19.5	30.0
32500.W0356	With Grip	6	M16x1,5	16	56.0	10	30	-	42	11.5	30.5	61.0
32500.W0355	With Grip	8	M12x1,5	12	47.0	8	26	-	32	8.5	19.5	32.0
32500.W0357	With Grip	8	M16x1,5	16	56.0	10	30	-	42	11.5	30.5	63.0
32500.W0358	With Grip	8	M20x1,5	20	69.0	12	36	-	52	21.0	57.5	124.0
32500.W0359	With Grip	10	M16x1,5	16	56.0	10	30	-	42	11.5	30.5	66.0
32500.W0360	With Grip	10	M20x1,5	20	69.0	12	36	-	52	21.0	57.5	128.0
32500.W0362	With Grip	12	M20x1,5	20	69.0	12	36	-	52	21.0	57.5	131.0

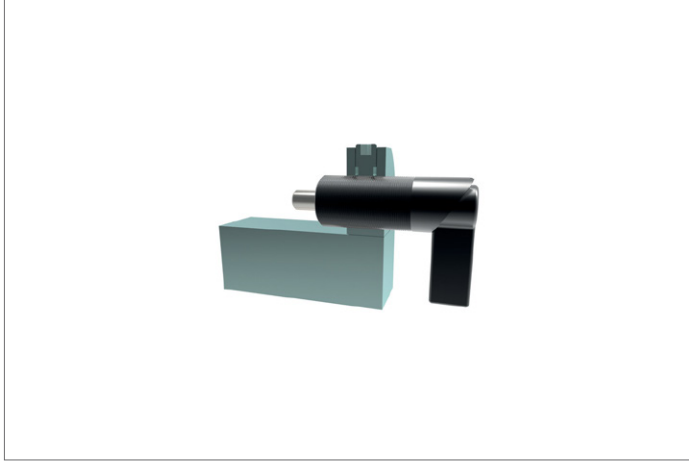



Index Plungers - Lever Grip

locking - stainless

Index Plunger & Pins

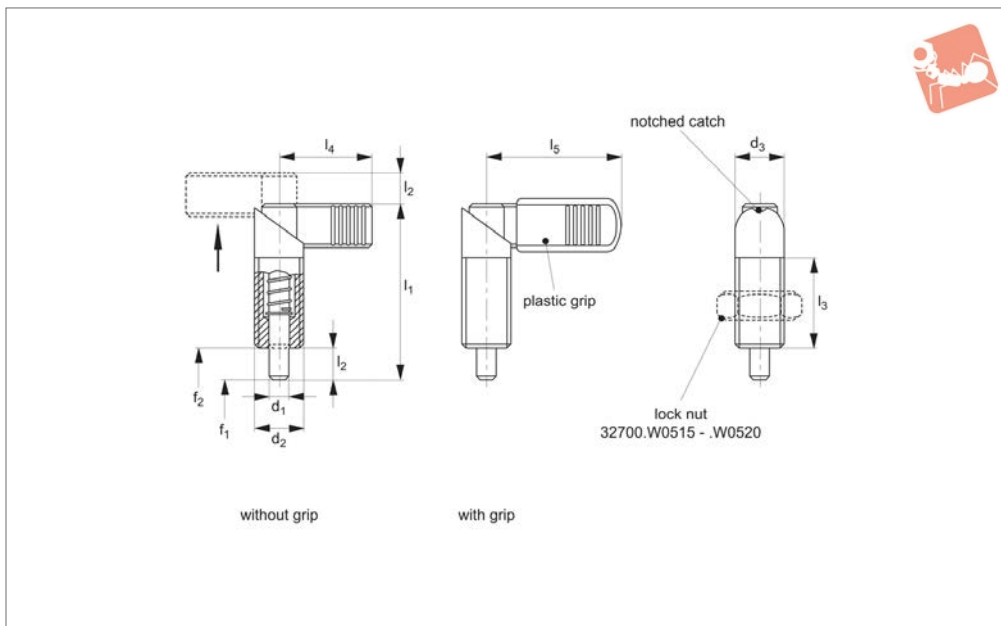

32501

INDEX PLUNGER & PINS

Material

Body: stainless steel 1.4305 (AISI 303).
Pin: stainless steel 1.4305 (AISI 303).
Plastic Grip: thermoplastic, black, dull.

Technical Notes

Turn lever 180° to retract pin. To enable

pin to be held in retracted position, secure lever in notched catch on plunger body.

Plastic grip type, improves handling.
Temperature resistance of type with plastic grip is -30°C to +80°C

Lock nuts sold separately. See products 65690 and 65692

Tips

Spring loads * = statistical average.

Order No.	Type	d_1 -0.02 -0.04	d_2	d_3	l_1 ≈	l_2 min.	l_3 +1.5	l_4	l_5	Spring load F_1 N ≈	Spring load F_2 N	Weight g
32501.W0308	Without Grip	4	M10x1,0	10	37.5	6	19	21	-	8.5	25.0	17
32501.W0310	Without Grip	5	M10x1,0	10	37.5	6	19	21	-	8.5	25.0	18
32501.W0312	Without Grip	6	M10x1,0	10	37.5	6	19	21	-	8.5	25.0	18
32501.W0323	Without Grip	5	M12x1,5	12	47	8	26	26	-	8.5	19.5	29.0
32501.W0324	Without Grip	6	M12x1,5	12	47	8	26	26	-	8.5	19.5	29.0
32501.W0326	Without Grip	6	M16x1,5	16	56	10	30	32	-	11.5	30.5	59.0
32501.W0325	Without Grip	8	M12x1,5	12	47	8	26	26	-	8.5	19.5	30.0
32501.W0327	Without Grip	8	M16x1,5	16	56	10	30	32	-	11.5	30.5	61.0
32501.W0328	Without Grip	8	M20x1,5	20	69	12	36	37	-	21.0	57.5	121.0
32501.W0329	Without Grip	10	M16x1,5	16	56	10	30	32	-	11.5	30.5	64.0
32501.W0330	Without Grip	10	M20x1,5	20	69	12	36	37	-	21.0	57.5	123.0
32501.W0332	Without Grip	12	M20x1,5	20	69	12	36	37	-	21.0	57.5	127.0
32501.W0363	With Grip	5	M12x1,5	12	47	8	26	-	32	8.5	19.5	30.0
32501.W0364	With Grip	6	M12x1,5	12	47	8	26	-	32	8.5	19.5	30.0
32501.W0366	With Grip	6	M16x1,5	16	56	10	30	-	42	11.5	30.5	61.0
32501.W0365	With Grip	8	M12x1,5	12	47	8	26	-	32	8.5	19.5	32.0
32501.W0367	With Grip	8	M16x1,5	16	56	10	30	-	42	11.5	30.5	63.0
32501.W0368	With Grip	8	M20x1,5	20	69	12	36	-	52	21.0	57.5	124.0
32501.W0369	With Grip	10	M16x1,5	16	56	10	30	-	42	11.5	30.5	66.0
32501.W0370	With Grip	10	M20x1,5	20	69	12	36	-	52	21.0	57.5	128.0
32501.W0372	With Grip	12	M20x1,5	20	69	12	36	-	52	21.0	57.5	131.0

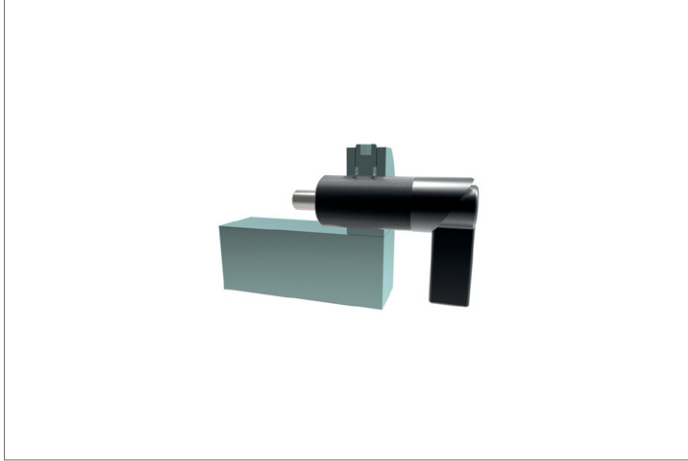



Index Plungers - Lever Grip locking - coarse thread

Index Plunger & Pins

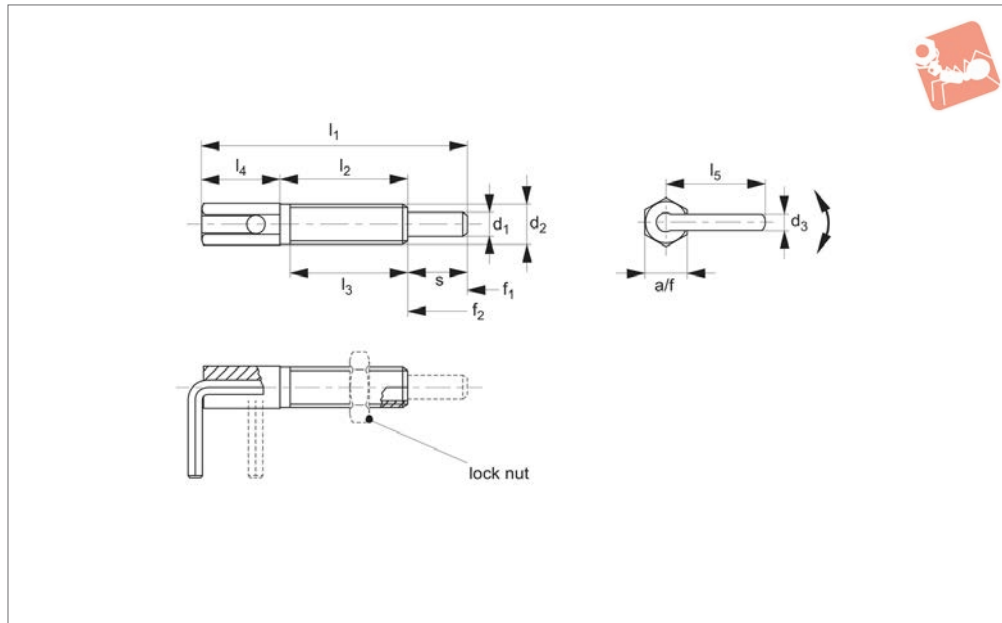

32555

INDEX PLUNGER & PINS

Material

Body: free cutting steel, zinc plated.
Pin: steel, galvanised.
Lever: steel, galvanised.

Technical Notes

Pull back and turn lever 180° to retract pin.

To enable pin to be held in retracted position, secure lever in notched catch on plunger body.

For applications where high precision is not required.

Coarse thread.

Temperature resistance up to 250°C

Lock nuts sold separately. See products 65690 and 65692

Tips

Spring loads* = statistical average.

Order No.	Type	d ₁	d ₂	d ₃	l ₁	l ₂	l ₃	l ₄	l ₅	s	A/F	Spring load F ₁ N ≈	Spring load F ₂ N ≈	Tightening torque Nm max.	Weight g
32555.W0105	Locking	4	M 6x1,00	2,3	41,5	20,0	17,0	12,0	15,5	9,5	6	3,0	10,0	1,6	6
32555.W0110	Locking	5	M 8x1,25	3,0	54,0	27,0	24,0	15,0	19,2	12,0	8	3,5	13,5	4,5	14
32555.W0115	Locking	6	M10x1,50	3,5	65,0	33,5	30,0	17,5	22,9	14,0	10	4,0	16,0	10,0	26
32555.W0120	Locking	8	M12x1,75	4,7	73,0	31,8	28,0	22,2	31,2	19,0	12	4,0	22,0	13,0	55
32555.W0125	Locking	10	M16x2,00	4,7	102,5	50,5	44,5	27,0	32,7	25,0	16	4,0	23,0	42,0	103



32520

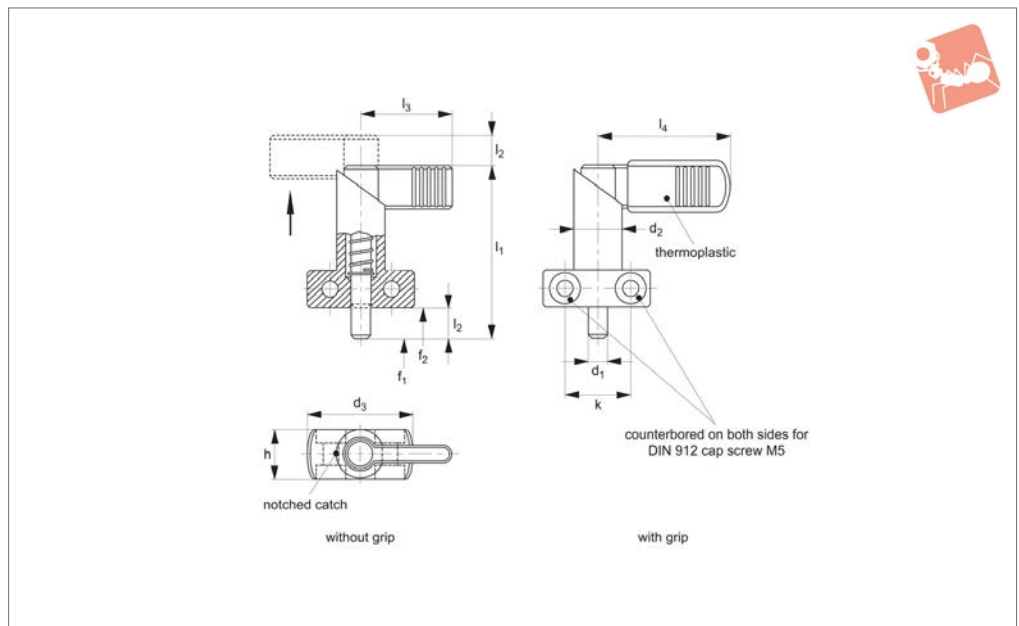

Material

Body & Lever: free cutting steel, blackened.

Pin: steel, nitrided, black.

Plastic Grip: thermoplastic, black, dull.

Technical Notes

Turn lever 180° to retract pin. To enable

pin to be held in retracted position, secure lever in notched catch on plunger body.

Countersunk holes on both sides of mounting flange enable both right or left mounting.

Plastic grip type, improves handling.

Temperature resistance of type with plastic

grip is -30°C to +80°C.

Tips

Spring loads * = statistical average.

Order No.	Type	d_1 0 -0.05	l_2	d_2	d_3	h	k	l_1	l_3	l_4	s	Spring load F_1 N ≈	Spring load F_2 N ≈	Weight g
32520.W0376	Without Grip	6	10	16	35	16	20	56	32	-	12	12	32	82
32520.W0378	Without Grip	8	10	16	35	16	20	56	32	-	12	12	32	85
32520.W0379	Without Grip	8	12	20	40	20	22	69	37	-	15	21	58	163
32520.W0381	Without Grip	10	10	16	35	16	20	56	32	-	12	12	32	85
32520.W0382	Without Grip	10	12	20	40	20	22	69	37	-	15	21	58	167
32520.W0384	Without Grip	12	12	20	40	20	22	69	37	-	15	21	58	168
32520.W0386	With Grip	6	10	16	35	16	20	56	-	42	12	12	32	83
32520.W0388	With Grip	8	10	16	35	16	20	56	-	42	12	12	32	85
32520.W0389	With Grip	8	12	20	40	20	22	69	-	52	15	21	58	169
32520.W0391	With Grip	10	10	16	35	16	20	56	-	42	12	12	32	86
32520.W0392	With Grip	10	12	20	40	20	22	69	-	52	15	21	58	171
32520.W0394	With Grip	12	12	20	40	20	22	69	-	52	15	21	58	171



Index Plungers - Lever Grip

flange mounting - locking

Index Plunger & Pins

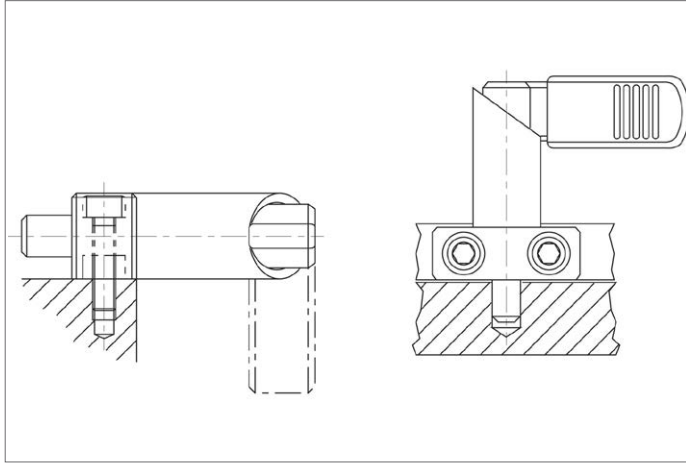

INDEX PLUNGER & PINS



32790

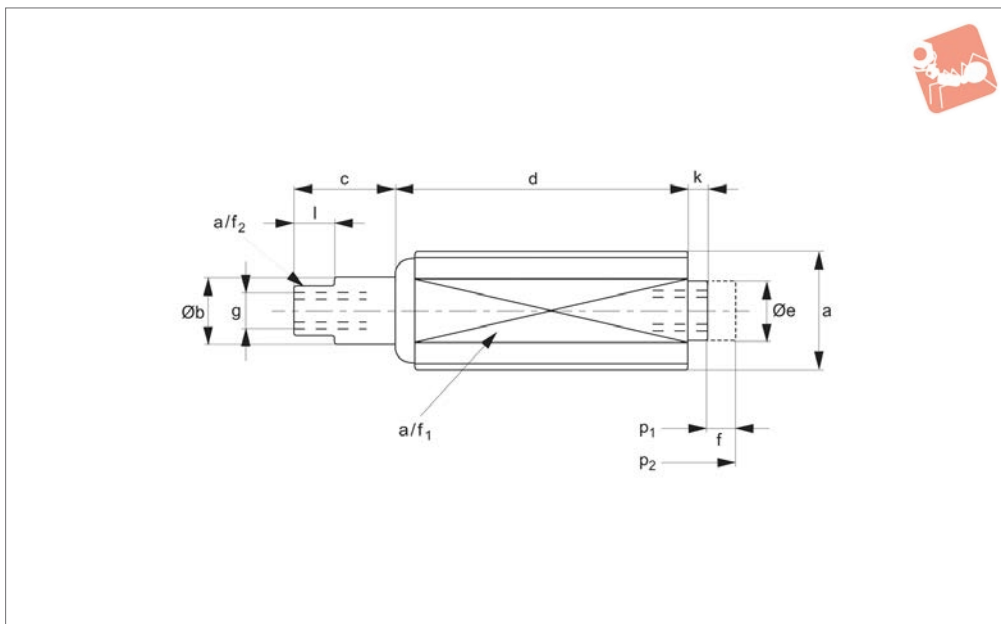

Material

Body: steel, blue galvanised.
Pins: steel, burnished.

Technical Notes

Ideal for either pressure (push) and

tension (pull) applications, due to the unique designs spring loaded pin with threads at both ends to allow installation of your own adaptor or handle.

A wide range of application: pressure

bolts, holding or magnets etc.
Requires very small space requirements.

Order No.	a	Ø b	c	d ₁	Ø e	f	g	A/F ₁	k	l	p ₁ N	p ₂ N	A/F ₂	Weight g
32790.W0120	M12	7	4.5	11.0	6	3.5	M 4x8	10	1.5	5	5	20	6	5
32790.W0121	M12	7	7.0	18.5	6	6.0	M 4x8	10	1.5	5	5	20	6	8
32790.W0122	M12	7	11.0	26.0	6	10.0	M 4x8	10	1.5	5	5	20	6	12
32790.W0130	M12	7	4.5	11.0	6	3.0	M 4x8	10	1.5	5	15	80	6	5
32790.W0131	M12	7	7.0	18.5	6	5.0	M 4x8	10	1.5	5	15	80	6	8
32790.W0132	M12	7	11.0	26.0	6	8.0	M 4x8	10	1.5	5	15	80	6	12
32790.W0140	M12	7	4.5	11.0	6	3.0	M 4x8	10	1.5	5	30	125	6	5
32790.W0141	M12	7	7.0	18.5	6	5.0	M 4x8	10	1.5	5	30	125	6	8
32790.W0142	M12	7	11.0	26.0	6	8.0	M 4x8	10	1.5	5	30	125	6	13
32790.W0180	M18x1,5	11	6.0	17.0	10	4.0	M 6x12	16	2.0	6	50	150	9	22
32790.W0181	M18x1,5	11	11.5	29.5	10	7.0	M 6x12	16	2.0	6	50	150	9	43
32790.W0182	M18x1,5	11	16.0	45.5	10	12.5	M 6x12	16	2.0	6	50	150	9	66

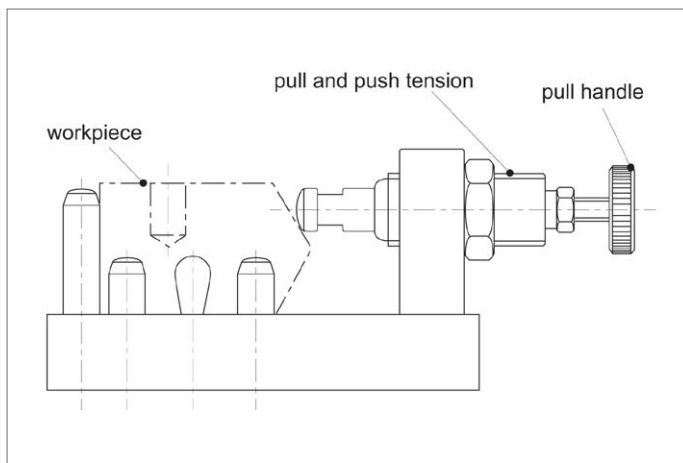
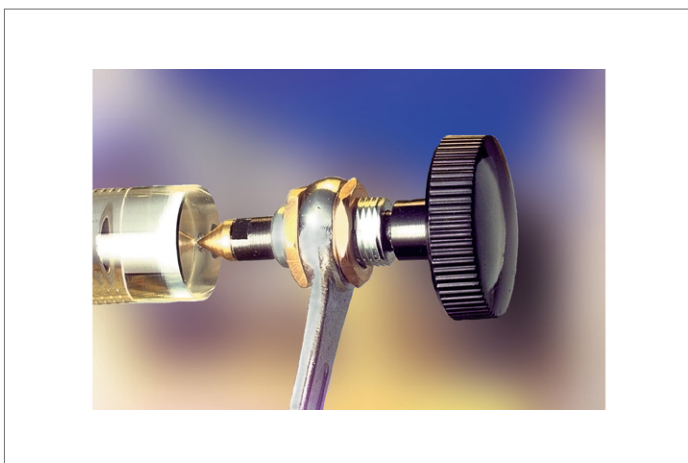

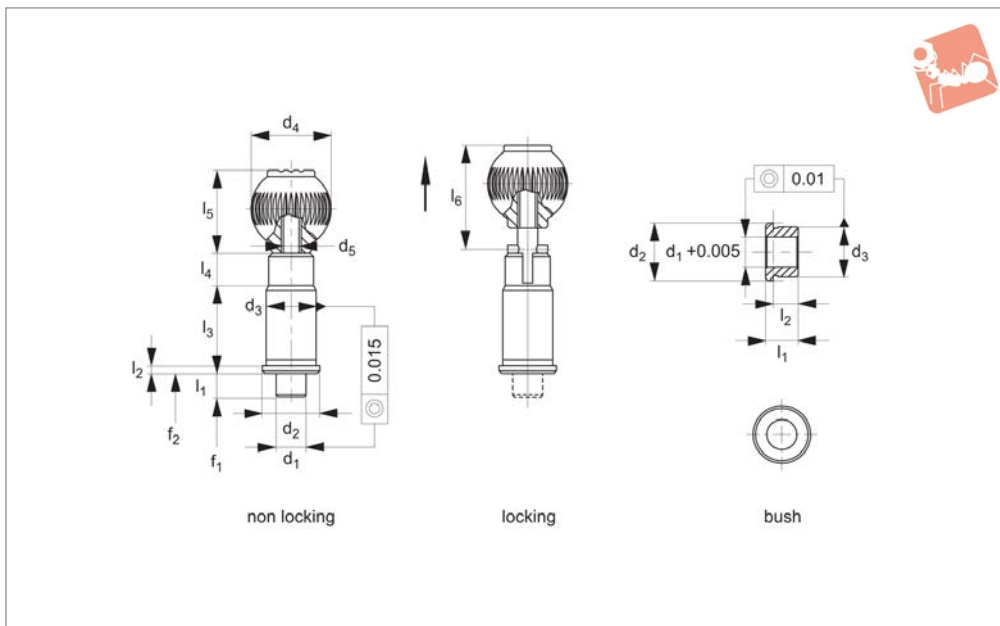

32460

INDEX PLUNGER & PINS

Material

Pin, Body & Bush: case-hardened steel, blackened and ground.
Grip: thermoplastic, black.

Technical Notes

Supplied part assembled to enable precise setting, grip and body must be glued after

mounting. Non removable once installed.

„**Locking**“ type - enable pin to be held in retracted/non-projecting position; pull back grip, turn 90 to engage „locking“ on a notched catch.

„**Non Locking**“ type - pin simply springs

back when grip released.

Tips

When used for alignment of two sub-plates, the plunger's precise finish guarantees high repetition accuracy.
Spring loads * = statistical average.

Order No.	Type	d_1 -0.005 -0.01	d_2	d_3 tol. n6	d_4	d_5	l_1 min.	l_2	l_3	l_4	l_5	l_6	Spring load F_1 N ≈	Spring load F_2 N ≈	Weight g
32460.W0010	Non Locking	10	19	16	25	M 6	10	2,5	31	13	25,0		15	30	79
32460.W0012	Non Locking	12	23	20	32	M 8	10	3,0	35	13	33,0		15	35	138
32460.W0016	Non Locking	16	28	25	40	M10	10	3,0	42	13	41,5		20	50	226
32460.W0020	Non Locking	20	33	30	40	M10	10	3,0	50	13	41,5		36	63	350
32460.W0025	Non Locking	25	42	38	50	M10	10	3,0	60	13	51,0		20	73	649
32460.W0060	Locking	10	19	16	25	M 6	10	2,5	31	13	25,0	36,5	15	30	79
32460.W0062	Locking	12	23	20	32	M 8	10	3,0	35	13	33,0	44,5	15	35	136
32460.W0066	Locking	16	28	25	40	M10	10	3,0	42	13	41,5	53,0	20	50	228
32460.W0070	Locking	20	33	30	40	M10	10	3,0	50	13	41,5	53,0	36	63	350
32460.W0075	Locking	25	42	38	50	M10	10	3,0	60	13	51,0	62,5	20	73	649
32460.W0090	Bush	10	19	16			11	8,5							11
32460.W0092	Bush	12	23	20			13	10,0							22
32460.W0093	Bush	16	28	25			17	14,0							40
32460.W0094	Bush	20	33	30			16	13,0							51
32460.W0096	Bush	25	42	38			19	16,0							99



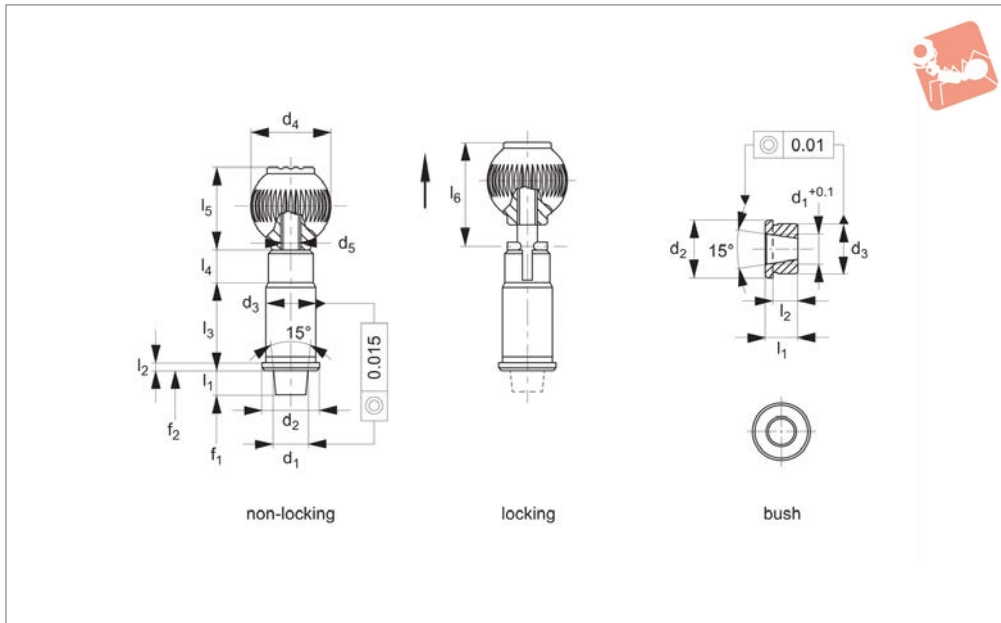

32480

INDEX PLUNGER & PINS

Material

Pin, body & bush: case hardened steel, blackened and ground.
Grip: thermoplastic, black.

Technical Notes

Supplied part assembled to enable precise setting, grip and body must be glued after

mounting. Non removable once installed.

„Locking“ type - enable pin to be held in retracted/non-projecting position; pull back grip, turn 90° to engage ‚locking‘ on a notched catch.

„Non Locking“ type - pin simply springs

back when grip released.

Tips

When used for alignment of two sub-plates, the plunger's precise finish on pin allows easier alignment of pin and bushing.

Spring loads * = statistical average.

Order No.	Type	Dia. Ø nom.	d ₁	d ₂	d ₃ tol. n6	d ₄	d ₅	l ₁ min.	l ₂	l ₃	l ₄	l ₅	l ₆	Spring load F ₁ N ≈	Spring load F ₂ N ≈	Weight g
32480.W0110	Non Locking	10	10,00	19	16	25	M 6	6	2,5	31	13	25,0		19	29	78
32480.W0112	Non Locking	12	12,00	23	20	32	M 8	6	3,0	35	13	33,0		22	35	135
32480.W0116	Non Locking	16	16,00	28	25	40	M10	6	3,0	42	13	41,5		30	50	227
32480.W0120	Non Locking	20	20,00	33	30	40	M10	6	3,0	50	13	41,5		46	63	348
32480.W0125	Non Locking	25	25,00	42	38	50	M10	6	3,0	60	13	51,0		39	73	654
32480.W0160	Locking	10	10,00	19	16	25	M 6	6	2,5	31	13	25,0	32,5	19	29	78
32480.W0162	Locking	12	12,00	23	20	32	M 8	6	3,0	35	13	33,0	40,5	22	35	135
32480.W0166	Locking	16	16,00	28	25	40	M10	6	3,0	42	13	41,5	49,0	30	50	228
32480.W0170	Locking	20	20,00	33	30	40	M10	6	3,0	50	13	41,5	49,0	46	63	348
32480.W0175	Locking	25	25,00	42	38	50	M10	6	3,0	60	13	51,0	58,5	39	73	651
32480.W0190	Tapered Bush	10	7,10	19	16			11	8,5							13
32480.W0192	Tapered Bush	12	8,28	23	20			13	10,0							25
32480.W0193	Tapered Bush	16	11,52	28	25			17	14,0							47
32480.W0194	Tapered Bush	20	15,49	33	30			16	13,0							60
32480.W0196	Tapered Bush	25	19,70	42	38			19	16,0							114

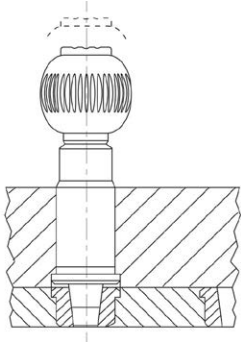

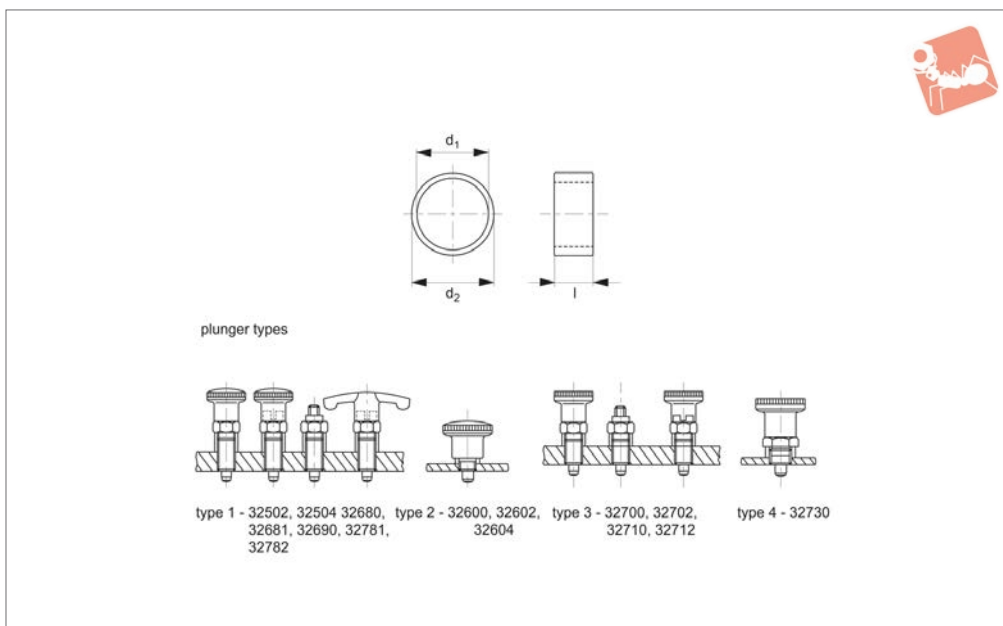
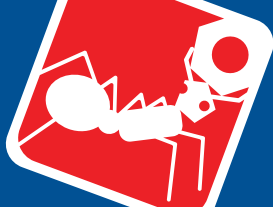

32750

INDEX PLUNGER & PINS

Material

Stainless steel 1.4305 (AISI 303).

index plungers to enable different thread reaches. Order while stocks last.

Technical Notes

Distance collars adapt the thread length of

Order No.	d ₁ tol. H12	d ₂ -0.1	For index plungers size d ₁	Suitable for plunger type	l ₁ ±0.1	Weight g
32750.W0933	8	10	M 8	1	3	0.8
32750.W0934	8	10	M 8	1	4	0.9
32750.W0936	8	10	M 8	1	6	1.2
32750.W0938	8	10	M 8	1	8	1.6
32750.W0940	8	10	M 8	1	10	2.0
32750.W0942	10	12	M10	1/2/3	2	0.6
32750.W0944	10	12	M10	1/2/3	4	1.1
32750.W0946	10	12	M10	1/3	6	1.6
32750.W0948	10	12	M10	1/3	8	2.1
32750.W0950	10	12	M10	1/3	10	2.7
32750.W0952	10	12	M10	1/3	12	3.0
32750.W0962	12	14	M12	1	2	0.6
32750.W0964	12	14	M12	1	4	2.5
32750.W0966	12	14	M12	1	6	1.9
32750.W0968	12	14	M12	1	8	2.4
32750.W0972	12	17	M12	3/4	2	2.0
32750.W0974	12	17	M12	3/4	4	3.4
32750.W0975	12	17	M12	3/4	5	4.4
32750.W0976	16	17	M16	1	4	0.7
32750.W0977	16	17	M16	1	6	1.2
32750.W0978	16	17	M16	1	8	1.4
32750.W0979	16	17	M16	1	10	2.0
32750.W0980	16	17	M16	1	12	2.1
32750.W0982	16	19	M16	3/4	2	1.3
32750.W0984	16	19	M16	3/4	4	2.8
32750.W0986	16	19	M16	3/4	6	3.8
32750.W0988	16	19	M16	3/4	8	4.8
32750.W0990	16	19	M16	3	10	6.1
32750.W0992	16	19	M16	3	12	9.2
32750.W0993	20	22	M20	1/3	6	3.0
32750.W0994	20	22	M20	1/3	8	4.0
32750.W0995	20	22	M20	1/3	10	4.9
32750.W0996	20	22	M20	1/3	12	5.9
32750.W0997	20	22	M20	1/3	14	6.9



Order No.	d_1 tol. H12	d_2 -0.1	For index plungers size d_1	Suitable for plunger type	l_1 ± 0.1	Weight g
32750.W0998	20	22	M20	1/3	16	9.3
32750.W0999	20	22	M20	1/3	18	9.0

INDEX PLUNGER & PINS





Mounting Blocks for index plungers - fine thread

Index Plunger & Pins

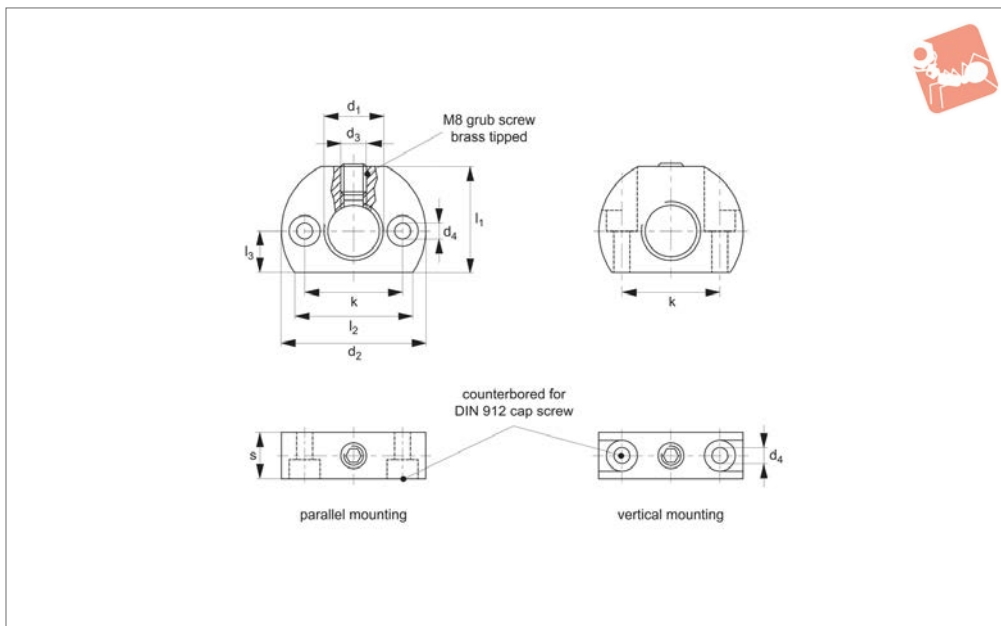

32510

INDEX PLUNGER & PINS

Material

Steel type-

Body: Steel, blackened.

Grub Screw: M8 with brass tip.

Stainless steel type-

Body: Stainless steel 1.4305 (AISI 303).

Technical Notes

Mounting blocks provide assembly support for mounting of index plungers. **(Not**

suitable for index plungers with coarse thread).

Order No.	Material	Type	d ₁	d ₂	d ₃	d ₄	k ±0.1	l ₁	l ₂ ≈	l ₃	s	Weight g
32510.W0345	Steel	Parallel	M12x1,5	32	M 5	4.5	21	22	26.5	9	12	43
32510.W0346	Steel	Parallel	M16x1,5	46	M 8	5.5	32	33	38.0	13	15	122
32510.W0347	Steel	Vertical	M12x1,5	32	M 5	4.5	21	22	26.5	9	12	37
32510.W0348	Steel	Vertical	M16x1,5	46	M 8	5.5	32	33	38.0	13	15	106
32510.W0350	Steel	Parallel	M20x1,5	46	M 8	5.5	32	33	37.0	13	15	109
32510.W0352	Steel	Vertical	M20x1,5	46	M 8	5.5	32	33	38.0	13	15	94
32510.W0545	Stainless	Parallel	M12x1,5	32	M 5	4.5	21	22	26.5	9	12	43
32510.W0546	Stainless	Parallel	M16x1,5	46	M 8	5.5	32	33	38.0	13	15	122
32510.W0547	Stainless	Vertical	M12x1,5	32	M 5	4.5	21	22	26.5	9	12	37
32510.W0548	Stainless	Vertical	M16x1,5	46	M 8	5.5	32	33	38.0	13	15	106
32510.W0550	Stainless	Parallel	M20x1,5	46	M 8	5.5	32	33	37.0	13	15	109
32510.W0552	Stainless	Vertical	M20x1,5	46	M 8	5.5	32	33	38.0	13	15	94

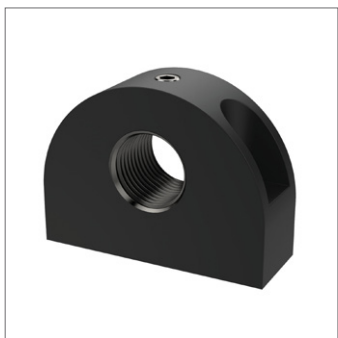

32512

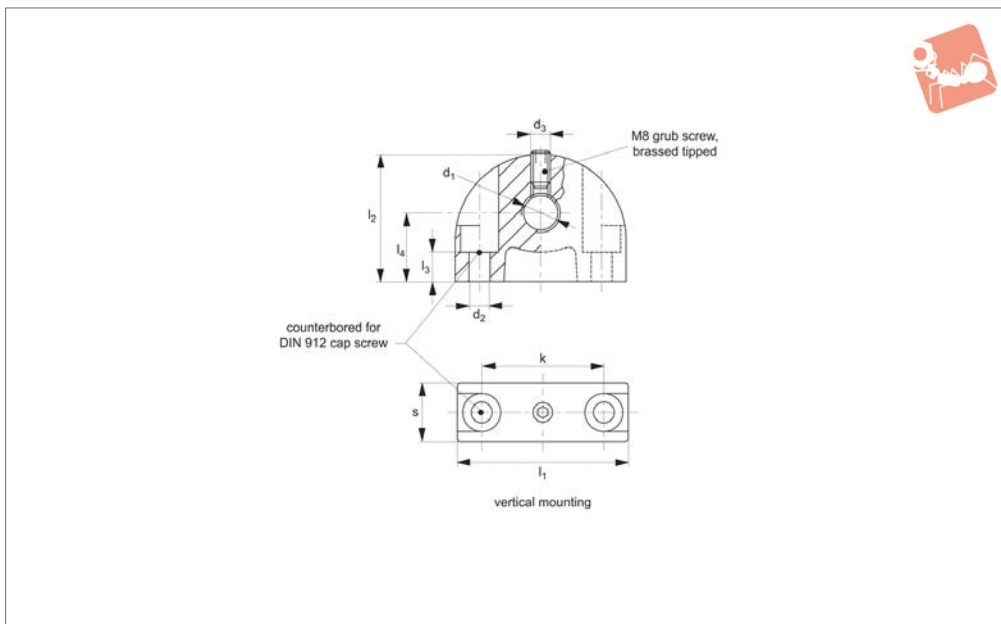

Material

Body: die-cast zinc, black plastic coated.
Grub screw: M8 with brass tip.

for mounting of index plungers. **(Not suitable for index plungers with coarse thread).**

d_1 on countersunk side.

Technical Notes

Mounting blocks provide assembly support

Index plunger must be assembled in hole

Order No.	Type	d_1	d_2	d_3	k	l_1	l_2	l_3 -0.2	l_4	Weight g
32512.W0408	Vertical	M 8x1,0	4.3	M 4	25	35	26	11.5	14	39
32512.W0410	Vertical	M10x1,0	4.3	M 4	25	35	26	11.5	14	36
32512.W0412	Vertical	M12x1,5	4.3	M 4	25	35	26	11.5	14	41
32512.W0416	Vertical	M16x1,5	5.3	M 5	35	47	34	15.5	18	77
32512.W0420	Vertical	M20x1,5	5.3	M 5	35	47	34	15.5	18	68

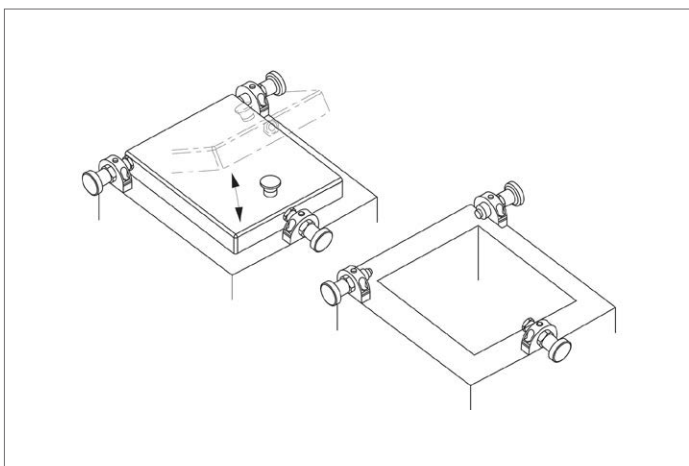



Locating Bushes for index plungers

Index Plunger & Pins

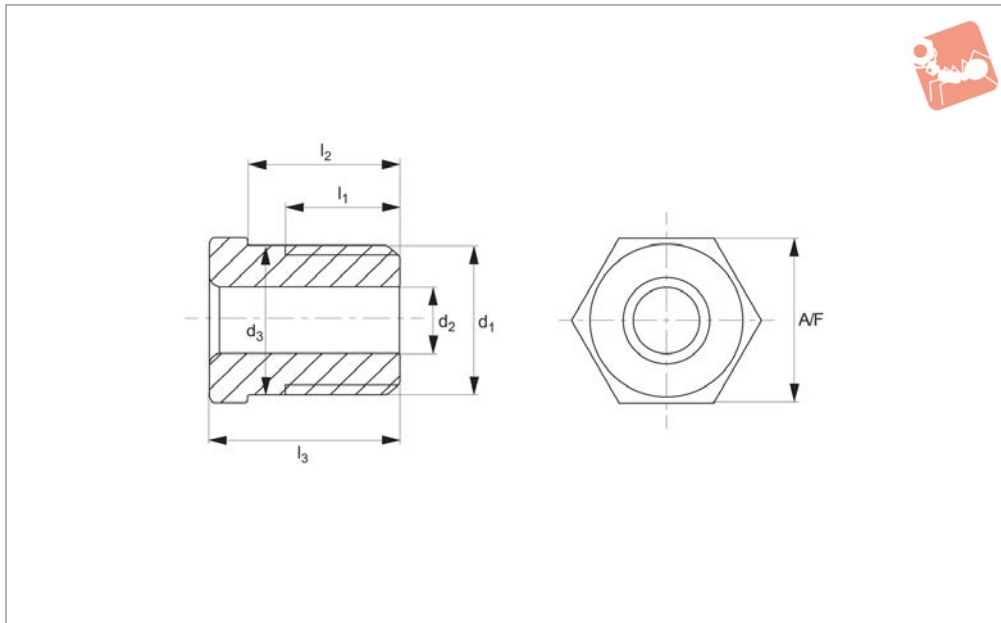

32752

INDEX PLUNGER & PINS

Material

Steel, nitrided.

Technical Notes

For use with our wide range of index plun-

gers. Provide a durable location bush for index plunger pins of diameter d_2 . See „for pin dia.“ column in data table and refer to individual index plunger production infor-

mation for matching pin diameters.

Order No.	d_1	For pin dia.	d_2 +0.1	d_3 ± 0.3	l_1 min.	l_2 -0.3	l_3	A/F	Weight g
32752.W0454	M12x1,5	4	4.2	12.1	9	10	13	13	10
32752.W0455	M12x1,5	5	5.2	12.1	9	10	13	13	10
32752.W0456	M12x1,5	6	6.2	12.1	9	10	13	13	9
32752.W0458	M16x1,5	8	8.2	16.1	11	12	15	17	18
32752.W0460	M16x1,5	10	10.2	16.1	11	12	15	17	14
32752.W0462	M16x1,5	12	12.2	16.1	11	12	15	17	9

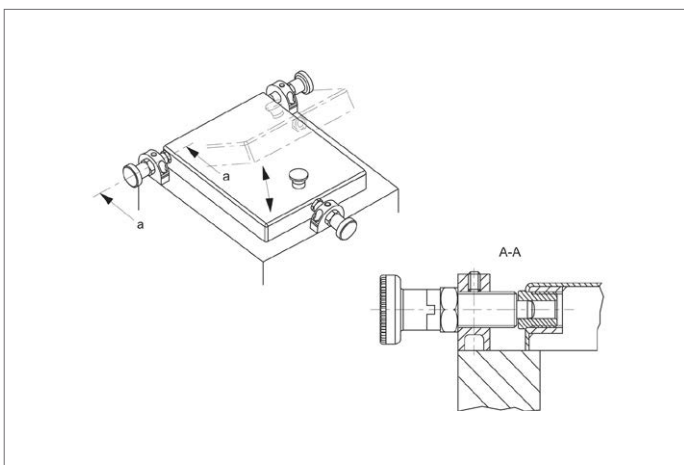



32753

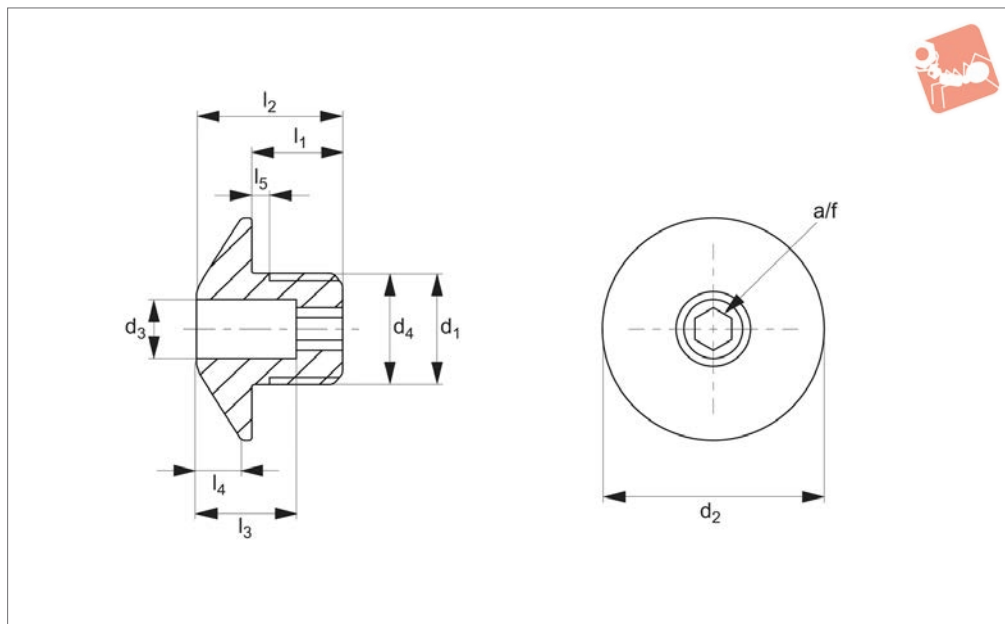

Material

Body:
Steel: Hardened, blackened
Stainless: Stainless steel hardened

and plungers. Provide a durable location bush for index plunger pins of diameter d_3 , refer to individual index plunger production information for matching pin diameters.

Tips

Low wear option due to hardened material.

Technical Notes

For use with our wide range of index bolts

Order No.	Type	d_1	d_2	d_3 +0,1	d_4 -0,05	l_1	l_2	l_3	l_4	l_5 +0,5	For pin	A/F	Weight g
32753.W0464	Steel	M12x1,5	24	4.2	12	10	16	11	5	1.5	4	4	17
32753.W0465	Steel	M12x1,5	24	5.2	12	10	16	11	5	1.5	5	4	16
32753.W0466	Steel	M12x1,5	24	6.2	12	10	16	11	5	1.5	6	4	16
32753.W0468	Steel	M16x1,5	32	8.2	16	12	20	13	7	1.5	8	6	36
32753.W0470	Steel	M16x1,5	32	10.2	16	12	20	13	7	1.5	10	6	33
32753.W0472	Steel	M16x1,5	32	12.2	16	12	20	13	7	1.5	12	6	33
32753.W0474	Stainless	M12x1,5	24	4.2	12	10	16	11	5	1.5	4	4	17
32753.W0475	Stainless	M12x1,5	24	5.2	12	10	16	11	5	1.5	5	4	16
32753.W0476	Stainless	M12x1,5	24	6.2	12	10	16	11	5	1.5	6	4	16
32753.W0478	Stainless	M16x1,5	32	8.2	16	12	20	13	7	1.5	8	6	36
32753.W0480	Stainless	M16x1,5	32	10.2	16	12	20	13	7	1.5	10	6	33
32753.W0482	Stainless	M16x1,5	32	12.2	16	12	20	13	7	1.5	12	6	33



Ball Lock Pins - Single Acting - Black

self-locking - stainless steel 1.4542 (AISI 630)

Ball Lock Pins & Quick Release

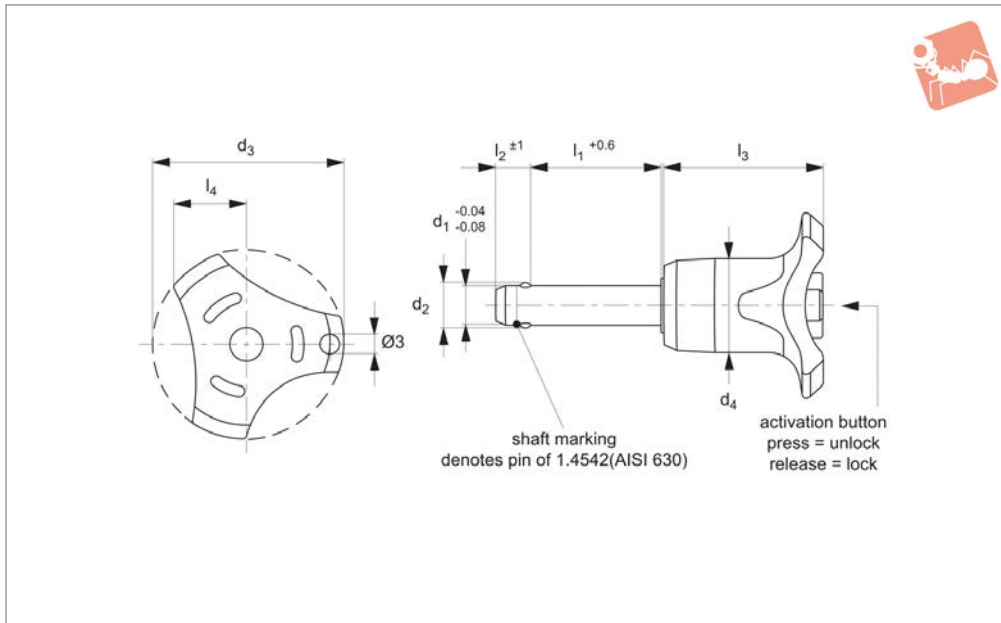

33060.BK

BALL LOCK PINS & QUICK RELEASE PINS

Material

Pin: stainless steel 1,4542 (AISI 630), precipitation hardened, blast finish. (marked at end of shaft to denote 1.4542 material).

Ball: stainless steel 1.3541

Spring: stainless steel.

Handle: thermoplastic PA 6.

Available colours: grey/orange, grey/blue, grey/grey, black/black.

Technical Notes

Pressing = unlocking.

Releasing = locking.

Temperature resistance -30°C to +80°C.

For quick fastening and locking of frequently repeated connections.

Tips

For lanyards & retaining cables see part no.33250. Easy install locating bushes

available see part no.33248.

Important Notes

Extreme load capacity due to high material grade.

*Shearing resistance similar to DIN 50141.

Also available in stainless grade 1.4305 (AISI 303), see part no.33080.

Order No.	d ₁	l ₁	d ₂	d ₃	d ₄	l ₂	l ₃	l ₄	Loc'n hole tol. H11	Shearing resistance, double kN min.	Weight g
33060.W0812	5	10	5.5	33.2	14.5	6.0	26.7	10.8	5	24	15
33060.W0813	5	15	5.5	33.2	14.5	6.0	26.7	10.8	5	24	15
33060.W0814	5	20	5.5	33.2	14.5	6.0	26.7	10.8	5	24	16
33060.W0815	5	25	5.5	33.2	14.5	6.0	26.7	10.8	5	24	17
33060.W0816	5	30	5.5	33.2	14.5	6.0	26.7	10.8	5	24	18
33060.W0817	6	60	7.0	33.2	14.5	7.0	26.7	10.8	6	21	26
33060.W0818	6	70	7.0	33.2	14.5	7.0	26.7	10.8	6	21	28
33060.W0819	6	80	7.0	33.2	14.5	7.0	26.7	10.8	6	21	30
33060.W0805	5	35	5.5	33.2	14.5	6.0	26.7	10.8	5	14	19
33060.W0806	5	40	5.5	33.2	14.5	6.0	26.7	10.8	5	14	20
33060.W0807	5	45	5.5	33.2	14.5	6.0	26.7	10.8	5	14	21
33060.W0808	5	50	5.5	33.2	14.5	6.0	26.7	10.8	5	14	23
33060.W0809	5	60	5.5	33.2	14.5	6.0	26.7	10.8	5	14	24
33060.W0810	5	70	5.5	33.2	14.5	6.0	26.7	10.8	5	14	18
33060.W0811	5	80	5.5	33.2	14.5	6.0	26.7	10.8	5	14	19
33060.W0821	8	100	9.6	39.2	18.4	8.2	33.3	13.4	8	38	54
33060.W0822	6	10	7.0	33.2	14.5	7.0	26.7	10.8	6	35	16
33060.W0823	6	15	7.0	33.2	14.5	7.0	26.7	10.8	6	35	17
33060.W0824	6	20	7.0	33.2	14.5	7.0	26.7	10.8	6	35	18
33060.W0825	6	25	7.0	33.2	14.5	7.0	26.7	10.8	6	35	19
33060.W0826	6	30	7.0	33.2	14.5	7.0	26.7	10.8	6	35	20
33060.W0827	6	35	7.0	33.2	14.5	7.0	26.7	10.8	6	35	21
33060.W0828	6	40	7.0	33.2	14.5	7.0	26.7	10.8	6	35	22
33060.W0829	6	45	7.0	33.2	14.5	7.0	26.7	10.8	6	35	23
33060.W0830	6	50	7.0	33.2	14.5	7.0	26.7	10.8	6	35	24
33060.W0831	8	90	9.6	39.2	18.4	8.2	33.3	13.4	8	38	36

Ball Lock Pins & Quick Release



Ball Lock Pins - Single Acting - Black

self-locking - stainless steel 1.4542 (AISI 630)



BALL LOCK PINS & QUICK RELEASE PINS

Order No.	d ₁	l ₁	d ₂	d ₃	d ₄	l ₂	l ₃	l ₄	Loc'n hole tol. H11	Shearing resistance, double kN min.	Weight g
33060.W0832	8	10	9.6	39.2	18.4	8.2	33.3	13.4	8	38	38
33060.W0833	8	15	9.6	39.2	18.4	8.2	33.3	13.4	8	38	58
33060.W0834	8	20	9.6	39.2	19.3	8.2	33.3	13.4	8	63	40
33060.W0835	8	25	9.6	39.2	19.3	8.2	33.3	13.4	8	63	40
33060.W0836	8	30	9.6	39.2	19.3	8.2	33.3	13.4	8	63	44
33060.W0837	8	35	9.6	39.2	19.3	8.2	33.3	13.4	8	63	44
33060.W0838	8	40	9.6	39.2	19.3	8.2	33.3	13.4	8	63	47
33060.W0839	8	45	9.6	39.2	19.3	8.2	33.3	13.4	8	63	47
33060.W0840	8	50	9.6	39.2	19.3	8.2	33.3	13.4	8	63	47
33060.W0841	8	60	9.6	39.2	18.4	8.2	33.3	13.4	8	38	62
33060.W0842	8	70	9.6	39.2	18.4	8.2	33.3	13.4	8	38	65
33060.W0843	8	80	9.6	39.2	18.4	8.2	33.3	13.4	8	38	69
33060.W0844	10	20	12.0	39.2	19.3	9.6	33.3	13.4	10	100	47
33060.W0845	10	25	12.0	39.2	19.3	9.6	33.3	13.4	10	100	49
33060.W0846	10	30	12.0	39.2	19.3	9.6	33.3	13.4	10	100	53
33060.W0847	10	35	12.0	39.2	19.3	9.6	33.3	13.4	10	100	55
33060.W0848	10	40	12.0	39.2	19.3	9.6	33.3	13.4	10	100	58
33060.W0849	10	45	12.0	39.2	19.3	9.6	33.3	13.4	10	100	61
33060.W0850	10	50	12.0	39.2	19.3	9.6	33.3	13.4	10	100	61
33060.W0851	10	15	12.0	39.2	18.4	9.6	33.3	13.4	10	60	86
33060.W0852	10	60	12.0	39.2	19.3	9.6	33.3	13.4	10	100	70
33060.W0853	10	70	12.0	39.2	18.4	9.6	33.3	13.4	10	60	91
33060.W0854	10	80	12.0	39.2	18.4	9.6	33.3	13.4	10	60	97
33060.W0855	10	90	12.0	39.2	18.4	9.6	33.3	13.4	10	60	103
33060.W0856	10	100	12.0	39.2	18.4	9.6	33.3	13.4	10	60	109
33060.W0857	10	110	12.0	39.2	18.4	9.6	33.3	13.4	10	60	115
33060.W0858	10	120	12.0	39.2	18.4	9.6	33.3	13.4	10	60	53
33060.W0864	12	20	14.5	47.6	25.2	10.6	39.7	16.7	12	87	156
33060.W0865	10	25	12.0	39.2	19.3	9.6	33.3	13.4	10	100	70
33060.W0866	12	30	14.5	47.6	26.3	10.6	39.7	16.7	12	144	100
33060.W0867	12	35	14.5	47.6	26.3	10.6	39.7	16.7	12	144	105
33060.W0868	12	40	14.5	47.6	26.3	10.6	39.7	16.7	12	144	105
33060.W0869	12	45	14.5	47.6	26.3	10.6	39.7	16.7	12	144	113
33060.W0870	12	50	14.5	47.6	26.3	10.6	39.7	16.7	12	144	117
33060.W0872	12	60	14.5	47.6	26.3	10.6	39.7	16.7	12	144	126
33060.W0874	12	70	14.5	47.6	26.3	10.6	39.7	16.7	12	144	134
33060.W0876	12	80	14.5	47.6	26.3	10.6	39.7	16.7	12	144	143
33060.W0877	12	90	14.5	47.6	25.2	10.6	39.7	16.7	12	87	165
33060.W0878	12	100	14.5	47.6	25.2	10.6	39.7	16.7	12	87	173
33060.W0879	12	110	14.5	47.6	25.2	10.6	39.7	16.7	12	87	182
33060.W0880	12	120	14.5	47.6	25.2	10.6	39.7	16.7	12	87	96
33060.W0886	16	30	19.0	47.6	26.3	14.0	39.7	16.7	16	257	132
33060.W0887	16	35	19.0	47.6	26.3	14.0	39.7	16.7	16	257	140
33060.W0888	16	40	19.0	47.6	26.3	14.0	39.7	16.7	16	257	148
33060.W0889	16	45	19.0	47.6	26.3	14.0	39.7	16.7	16	257	155
33060.W0890	16	45	19.0	47.6	26.3	14.0	39.7	16.7	16	257	155
33060.W0892	16	60	19.0	47.6	26.3	14.0	39.7	16.7	16	257	178
33060.W0894	16	70	19.0	47.6	26.3	14.0	39.7	16.7	16	257	194
33060.W0896	16	80	19.0	47.6	26.3	14.0	39.7	16.7	16	257	208
33060.W0897	16	90	19.0	47.6	25.2	14.0	39.7	16.7	16	155	234
33060.W0898	16	10	19.0	47.6	25.2	14.0	39.7	16.7	16	155	251
33060.W0899	16	110	19.0	47.6	25.2	14.0	39.7	16.7	16	155	266
33060.W0900	16	120	19.0	47.6	25.2	14.0	39.7	16.7	16	155	281
33060.W0901	16	130	19.0	47.6	25.2	14.0	39.7	16.7	16	155	297
33060.W0902	16	140	19.0	47.6	25.2	14.0	39.7	16.7	16	155	313
33060.W0903	16	150	19.0	47.6	25.2	14.0	39.7	16.7	16	155	328
33060.W0904	20	60	25.0	57.1	35.4	20.5	50.7	21.5	20	403	343
33060.W0905	20	50	25.0	57.1	33.8	20.5	50.7	21.5	20	403	329
33060.W0906	20	70	25.0	57.1	33.8	20.5	50.7	21.5	20	403	377
33060.W0907	20	90	25.0	57.1	33.8	20.5	50.7	21.5	20	403	426
33060.W0908	20	80	25.0	57.1	35.4	20.5	50.7	21.5	20	403	392
33060.W0912	20	100	25.0	57.1	35.4	20.5	50.7	21.5	20	403	440
33060.W0913	20	110	25.0	57.1	33.8	20.5	50.7	21.5	20	403	474
33060.W0916	20	120	25.0	57.1	33.8	20.5	50.7	21.5	20	403	488
33060.W0917	20	130	25.0	57.1	33.8	20.5	50.7	21.5	20	403	523
33060.W0918	20	140	25.0	57.1	33.8	20.5	50.7	21.5	20	403	546
33060.W0919	20	150	25.0	57.1	33.8	20.5	50.7	21.5	20	403	571



Ball Lock Pins - Single Acting - Black

self-locking - stainless steel 1.4542 (AISI 630)

Ball Lock Pins & Quick Release



Order No.	d ₁	l ₁	d ₂	d ₃	d ₄	l ₂	l ₃	l ₄	Loc'n hole tol. H11	Shearing resistance, double kN min.	Weight g
33060.W0921	25	50	30.8	57.1	33.8	22.0	50.7	21.5	25	631	415
33060.W0922	25	60	30.8	57.1	33.8	22.0	50.7	21.5	25	631	453
33060.W0923	25	70	30.8	57.1	33.8	22.0	50.7	21.5	25	631	490
33060.W0924	25	80	30.8	57.1	33.8	22.0	50.7	21.5	25	631	528
33060.W0925	25	90	30.8	57.1	33.8	22.0	50.7	21.5	25	631	565
33060.W0926	25	100	30.8	57.1	33.8	22.0	50.7	21.5	25	631	603
33060.W0927	25	110	30.8	57.1	33.8	22.0	50.7	21.5	25	631	640
33060.W0928	25	120	30.8	57.1	33.8	22.0	50.7	21.5	25	631	678
33060.W0929	25	130	30.8	57.1	33.8	22.0	50.7	21.5	25	631	715
33060.W0930	25	140	30.8	57.1	33.8	22.0	50.7	21.5	25	631	753
33060.W0931	25	150	30.8	57.1	33.8	22.0	50.7	21.5	25	631	790

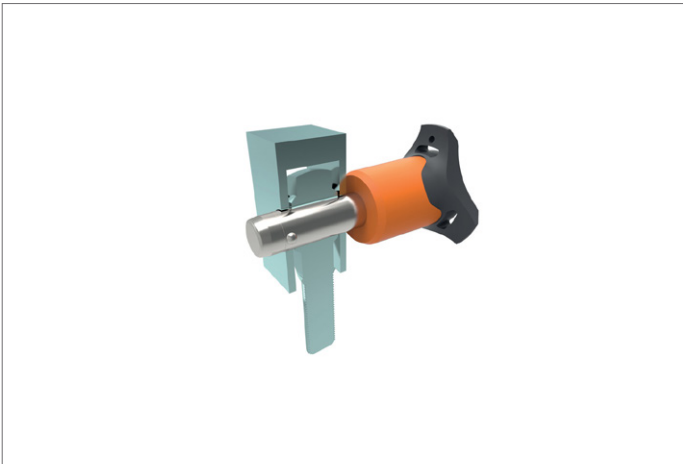

BALL LOCK PINS & QUICK RELEASE PINS

Ball Lock Pins & Quick Release

Ball Lock Pins - Single Acting - Blue

self-locking - stainless steel 1.4542 (AISI 630)



BALL LOCK PINS & QUICK RELEASE PINS



33060.BU

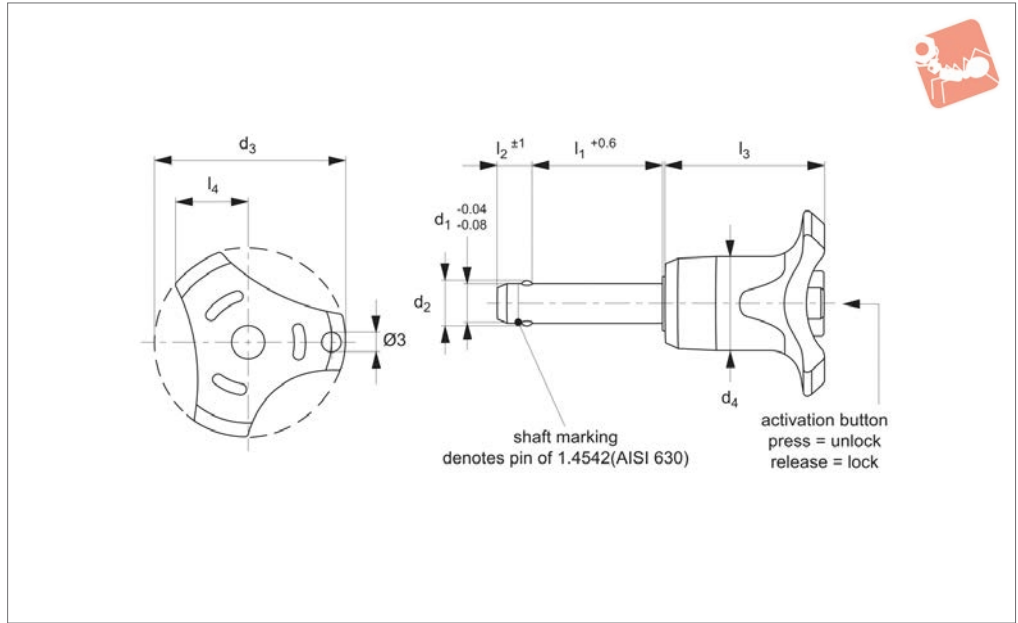

Material

Pin: stainless steel 1,4542 (AISI 630), precipitation hardened, blast finish. (marked at end of shaft to denote 1.4542 material).
 Ball: stainless steel 1.3541
 Spring: stainless steel.
 Handle: thermoplastic PA 6.
 Available colours: grey/orange, grey/blue, grey/grey, black/black.

Technical Notes

Pressing = unlocking.
 Releasing = locking.
 Temperature resistance -30°C to +80°C.
 For quick fastening and locking of frequently repeated connections.

Tips

For lanyards & retaining cables see part no.33250. Easy install locating bushes

available see part no.33248.

Important Notes

Extreme load capacity due to high material grade.
 *Shearing resistance similar to DIN 50141. Also available in stainless grade 1.4305 (AISI 303), see part no.33080.

Order No.	d ₁	l ₁	d ₂	d ₃	d ₄	l ₂	l ₃	l ₄	Loc'n hole tol. H11	Shearing resistance, double kN min.	Weight g
33060.W0432	5	10	5.5	33.2	14.5	6.0	26.7	10.8	5	24	15
33060.W0433	5	15	5.5	33.2	14.5	6.0	26.7	10.8	5	24	15
33060.W0434	5	20	5.5	33.2	14.5	6.0	26.7	10.8	5	24	16
33060.W0435	5	25	5.5	33.2	14.5	6.0	26.7	10.8	5	24	17
33060.W0436	5	30	5.5	33.2	14.5	6.0	26.7	10.8	5	24	18
33060.W0437	6	60	7.0	33.2	14.5	7.0	26.7	10.8	6	21	26
33060.W0438	6	70	7.0	33.2	14.5	7.0	26.7	10.8	6	21	28
33060.W0439	6	80	7.0	33.2	14.5	7.0	26.7	10.8	6	21	30
33060.W0425	5	35	5.5	33.2	14.5	6.0	26.7	10.8	5	14	19
33060.W0426	5	40	5.5	33.2	14.5	6.0	26.7	10.8	5	14	20
33060.W0427	5	45	5.5	33.2	14.5	6.0	26.7	10.8	5	14	21
33060.W0428	5	50	5.5	33.2	14.5	6.0	26.7	10.8	5	14	23
33060.W0429	5	60	5.5	33.2	14.5	6.0	26.7	10.8	5	14	24
33060.W0430	5	70	5.5	33.2	14.5	6.0	26.7	10.8	5	14	18
33060.W0431	5	80	5.5	33.2	14.5	6.0	26.7	10.8	5	14	19
33060.W0441	8	100	9.6	39.2	18.4	8.2	33.3	10.8,13.4	8	38	54
33060.W0442	6	10	7.0	33.2	14.5	7.0	26.7	10.8	6	35	16
33060.W0443	6	15	7.0	33.2	14.5	7.0	26.7	10.8	6	35	17
33060.W0444	6	20	7.0	33.2	14.5	7.0	26.7	10.8	6	35	18
33060.W0445	6	25	7.0	33.2	14.5	7.0	26.7	10.8	6	35	19
33060.W0446	6	30	7.0	33.2	14.5	7.0	26.7	10.8	6	35	20
33060.W0447	6	35	7.0	33.2	14.5	7.0	26.7	10.8	6	35	21
33060.W0448	6	40	7.0	33.2	14.5	7.0	26.7	10.8	6	35	22
33060.W0449	6	45	7.0	33.2	14.5	7.0	26.7	10.8	6	35	23
33060.W0450	6	50	7.0	33.2	14.5	7.0	26.7	10.8	6	35	24
33060.W0451	8	90	9.6	39.2	18.4	8.2	33.3	13.4	8	38	36

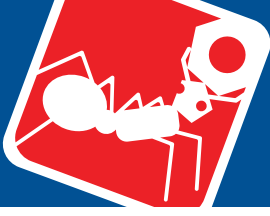

Ball Lock Pins - Single Acting - Blue self-locking - stainless steel 1.4542 (AISI 630)

Ball Lock Pins & Quick Release

Order No.	d ₁	l ₁	d ₂	d ₃	d ₄	l ₂	l ₃	l ₄	Loc'n hole tol. H11	Shearing resistance, double kN min.	Weight g
33060.W0452	8	10	9.6	39.2	18.4	8.2	33.3	13.4	8	38	24
33060.W0453	8	15	9.6	39.2	18.4	8.2	33.3	13.4	8	38	58
33060.W0454	8	20	9.6	39.2	19.3	8.2	33.3	13.4	8	63	40
33060.W0455	8	25	9.6	39.2	19.3	8.2	33.3	13.4	8	63	42
33060.W0456	8	30	9.6	39.2	19.3	8.2	33.3	13.4	8	63	44
33060.W0457	8	35	9.6	39.2	19.3	8.2	33.3	13.4	8	63	46
33060.W0458	8	40	9.6	39.2	19.3	8.2	33.3	13.4	8	63	47
33060.W0459	8	45	9.6	39.2	19.3	8.2	33.3	13.4	8	63	49
33060.W0460	8	50	9.6	39.2	18.4	8.2	33.3	13.4	8	63	51
33060.W0461	8	60	9.6	39.2	18.4	8.2	33.3	13.4	8	38	62
33060.W0462	8	70	9.6	39.2	18.4	8.2	33.3	13.4	8	38	65
33060.W0463	8	80	9.6	39.2	18.4	8.2	33.3	13.4	8	38	69
33060.W0464	10	20	12.0	39.2	19.3	9.6	33.3	13.4	10	100	47
33060.W0465	10	25	12.0	39.2	19.3	9.6	33.3	13.4	10	100	49
33060.W0466	10	30	12.0	39.2	19.3	9.6	33.3	13.4	10	100	53
33060.W0467	10	35	12.0	39.2	19.3	9.6	33.3	13.4	10	100	55
33060.W0468	10	40	12.0	39.2	19.3	9.6	33.3	13.4	10	100	58
33060.W0469	10	45	12.0	39.2	19.3	9.6	33.3	13.4	10	100	61
33060.W0470	10	50	12.0	39.2	19.3	9.6	33.3	13.4	10	100	64
33060.W0471	10	15	12.0	39.2	18.4	9.6	33.3	13.4	10	60	86
33060.W0472	10	60	12.0	39.2	19.3	9.6	33.3	13.4	10	100	70
33060.W0473	10	70	12.0	39.2	18.4	9.6	33.3	13.4	10	60	91
33060.W0474	10	80	12.0	39.2	18.4	9.6	33.3	13.4	10	60	97
33060.W0475	10	90	12.0	39.2	18.4	9.6	33.3	13.4	10	60	103
33060.W0476	10	100	12.0	39.2	18.4	9.6	33.3	13.4	10	60	109
33060.W0477	10	110	12.0	39.2	18.4	9.6	33.3	13.4	10	60	115
33060.W0478	10	120	12.0	39.2	18.4	9.6	33.3	13.4	10	60	53
33060.W0484	12	20	14.5	47.6	25.2	10.6	39.7	16.7	12	87	156
33060.W0485	12	25	14.5	47.6	26.3	10.6	39.7	16.7	12	144	96
33060.W0486	12	30	14.5	47.6	26.3	10.6	39.7	16.7	12	144	100
33060.W0487	12	35	14.5	47.6	26.3	10.6	39.7	16.7	12	144	105
33060.W0488	12	40	14.5	47.6	26.3	10.6	39.7	16.7	12	144	109
33060.W0489	12	45	14.5	47.6	26.3	10.6	39.7	16.7	12	144	113
33060.W0490	12	50	14.5	47.6	26.3	10.6	39.7	16.7	12	144	117
33060.W0492	12	60	14.5	47.6	26.3	10.6	39.7	16.7	12	144	126
33060.W0494	12	70	14.5	47.6	26.3	10.6	39.7	16.7	12	144	134
33060.W0496	12	80	14.5	47.6	26.3	10.6	39.7	16.7	12	144	143
33060.W0497	12	90	14.5	47.6	25.2	10.6	39.7	16.7	12	87	165
33060.W0498	12	100	14.5	47.6	25.2	10.6	39.7	16.7	12	87	173
33060.W0499	12	110	14.5	47.6	25.2	10.6	39.7	16.7	12	87	182
33060.W0500	12	120	14.5	47.6	25.2	10.6	39.7	16.7	12	87	96
33060.W0506	16	30	19.0	47.6	26.3	14.0	39.7	16.7	16	257	132
33060.W0507	16	35	19.0	47.6	26.3	14.0	39.7	16.7	16	257	140
33060.W0508	16	40	19.0	47.6	26.3	14.0	39.7	16.7	16	257	148
33060.W0509	16	45	19.0	47.6	26.3	14.0	39.7	16.7	16	257	155
33060.W0510	16	50	19.0	47.6	26.3	14.0	39.7	16.7	16	257	168
33060.W0512	16	60	19.0	47.6	26.3	14.0	39.7	16.7	16	257	178
33060.W0514	16	70	19.0	47.6	26.3	14.0	39.7	16.7	16	257	194
33060.W0516	16	80	19.0	47.6	26.3	14.0	39.7	16.7	16	257	208
33060.W0517	16	90	19.0	47.6	25.2	14.0	39.7	16.7	16	155	234
33060.W0518	16	100	19.0	47.6	25.2	14.0	39.7	16.7	16	155	251
33060.W0519	16	110	19.0	47.6	25.2	14.0	39.7	16.7	16	155	266
33060.W0520	16	120	19.0	47.6	25.2	14.0	39.7	16.7	16	155	281
33060.W0521	16	130	19.0	47.6	25.2	14.0	39.7	16.7	16	155	297
33060.W0522	16	140	19.0	47.6	25.2	14.0	39.7	16.7	16	155	313
33060.W0523	16	150	19.0	47.6	25.2	14.0	39.7	16.7	16	155	328
33060.W0531	20	50	25.0	57.1	33.8	20.5	50.7	21.5	20	403	329
33060.W0532	20	60	25.0	57.1	35.4	20.5	50.7	21.5	20	403	343
33060.W0533	20	70	25.0	57.1	33.8	20.5	50.7	21.5	20	403	377
33060.W0536	20	80	25.0	57.1	35.4	20.5	50.7	21.5	20	403	392
33060.W0537	20	90	25.0	57.1	33.8	20.5	50.7	21.5	20	403	426
33060.W0540	20	100	25.0	57.1	35.4	20.5	50.7	21.5	20	403	440
33060.W0541	20	110	25.0	57.1	33.8	20.5	50.7	21.5	20	403	474
33060.W0544	20	120	25.0	57.1	33.8	20.5	50.7	21.5	20	403	488
33060.W0545	20	130	25.0	57.1	33.8	20.5	50.7	21.5	20	403	523
33060.W0546	20	140	25.0	57.1	33.8	20.5	50.7	21.5	20	403	546
33060.W0547	20	150	25.0	57.1	33.8	20.5	50.7	21.5	20	403	571

BALL LOCK PINS & QUICK RELEASE PINS

Ball Lock Pins & Quick Release

Ball Lock Pins - Single Acting - Blue

self-locking - stainless steel 1.4542 (AISI 630)



BALL LOCK PINS & QUICK RELEASE PINS

Order No.	d ₁	l ₁	d ₂	d ₃	d ₄	l ₂	l ₃	l ₄	Loc'n hole tol. H11	Shearing resistance, double kN min.	Weight g
33060.W0549	25	50	30.8	57.1	33.8	22.0	50.7	21.5	25	631	415
33060.W0550	25	60	30.8	57.1	33.8	22.0	50.7	21.5	25	631	453
33060.W0551	25	70	30.8	57.1	33.8	22.0	50.7	21.5	25	631	490
33060.W0552	25	80	30.8	57.1	33.8	22.0	50.7	21.5	25	631	528
33060.W0553	25	90	30.8	57.1	33.8	22.0	50.7	21.5	25	631	565
33060.W0554	25	100	30.8	57.1	33.8	22.0	50.7	21.5	25	631	603
33060.W0555	25	110	30.8	57.1	33.8	22.0	50.7	21.5	25	631	640
33060.W0556	25	120	30.8	57.1	33.8	22.0	50.7	21.5	25	631	678
33060.W0557	25	130	30.8	57.1	33.8	22.0	50.7	21.5	25	631	715
33060.W0558	25	140	30.8	57.1	33.8	22.0	50.7	21.5	25	631	753
33060.W0559	25	150	30.8	57.1	33.8	22.0	50.7	21.5	25	631	790

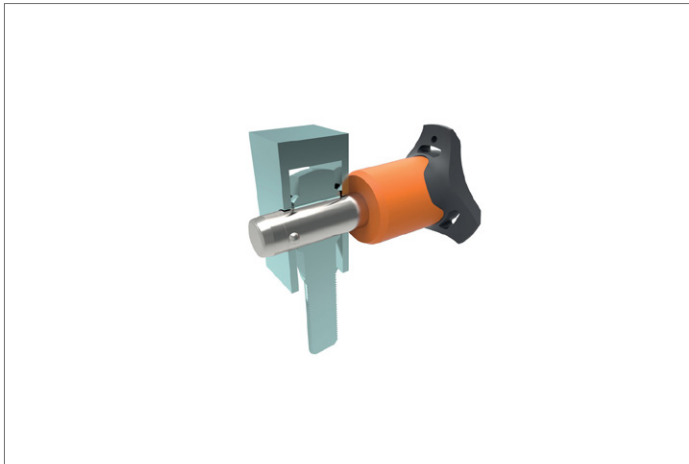



Ball Lock Pins - Single Acting - Grey self-locking - stainless steel 1.4542 (AISI 630)

Ball Lock Pins & Quick Release

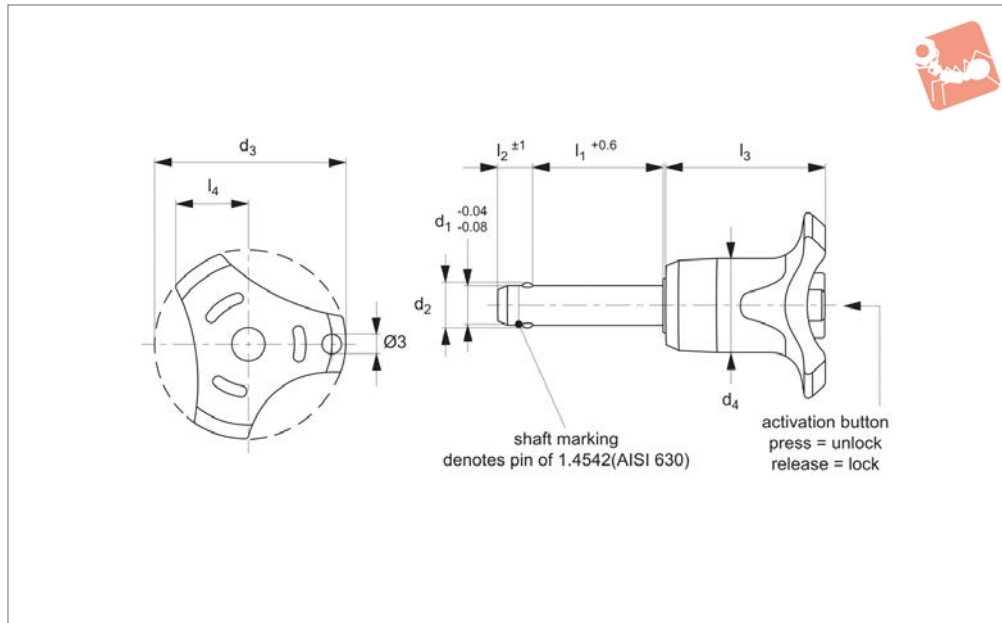

33060.GR

BALL LOCK PINS & QUICK RELEASE PINS

Material

Pin: stainless steel 1,4542 (AISI 630), precipitation hardened, blast finish. (marked at end of shaft to denote 1.4542 material).

Ball: stainless steel 1.3541

Spring: stainless steel.

Handle: thermoplastic PA 6.

Available colours: grey/orange, grey/blue, grey/grey, black/black.

Technical Notes

Pressing = unlocking.

Releasing = locking.

Temperature resistance -30°C to +80°C.

For quick fastening and locking of frequently repeated connections.

Tips

For lanyards & retaining cables see part no.33250. Easy install locating bushes

available see part no.33248.

Important Notes

Extreme load capacity due to high material grade.

*Shearing resistance similar to DIN 50141.

Also available in stainless grade 1.4305 (AISI 303), see part no.33080.

Order No.	d_1	l_1	d_2	d_3	d_4	l_2	l_3	l_4	Loc'n hole tol. H11	Shearing resistance, double kN min.	Weight g
33060.W0292	5	10	5.5	33.2	14.5	6.0	26.7	10.8	5	24	15
33060.W0293	5	15	5.5	33.2	14.5	6.0	26.7	10.8	5	24	15
33060.W0294	5	20	5.5	33.2	14.5	6.0	26.7	10.8	5	24	16
33060.W0295	5	25	5.5	33.2	14.5	6.0	26.7	10.8	5	24	17
33060.W0296	5	30	5.5	33.2	14.5	6.0	26.7	10.8	5	24	18
33060.W0297	6	60	7.0	33.2	14.5	7.0	26.7	10.8	6	21	26
33060.W0298	6	70	7.0	33.2	14.5	7.0	26.7	10.8	6	21	28
33060.W0299	6	80	7.0	33.2	14.5	7.0	26.7	10.8	6	21	30
33060.W0285	5	35	5.5	33.3	14.5	6.0	26.7	10.8	5	14	19
33060.W0286	5	40	5.5	33.4	14.5	6.0	26.7	10.8	5	14	20
33060.W0287	5	45	5.5	33.5	14.5	6.0	26.7	10.8	5	14	21
33060.W0288	5	50	5.5	33.6	14.5	6.0	26.7	10.8	5	14	23
33060.W0289	5	60	5.5	33.7	14.5	6.0	26.7	10.8	5	14	24
33060.W0290	5	70	5.5	33.8	14.5	6.0	26.7	10.8	5	14	18
33060.W0291	5	80	5.5	33.9	14.5	6.0	26.7	10.8	5	14	19
33060.W0301	8	100	9.6	39.2	18.4	8.2	33.3	13.4	8	38	54
33060.W0302	6	10	7.0	33.2	14.5	7.0	26.7	10.8	6	35	16
33060.W0303	6	15	7.0	33.2	14.5	7.0	26.7	10.8	6	35	17
33060.W0304	6	20	7.0	33.2	14.5	7.0	26.7	10.8	6	35	18
33060.W0305	6	25	7.0	33.2	14.5	7.0	26.7	10.8	6	35	19
33060.W0306	6	30	7.0	33.2	14.5	7.0	26.7	10.8	6	35	20
33060.W0307	6	35	7.0	33.2	14.5	7.0	26.7	10.8	6	35	21
33060.W0308	6	40	7.0	33.2	14.5	7.0	26.7	10.8	6	35	22
33060.W0309	6	45	7.0	33.2	14.5	7.0	26.7	10.8	6	35	23
33060.W0310	6	50	7.0	33.2	14.5	7.0	26.7	10.8	6	35	24
33060.W0311	8	90	7.0	39.2	18.4	8.2	33.3	13.4	8	38	36

Ball Lock Pins & Quick Release

Ball Lock Pins - Single Acting - Grey

self-locking - stainless steel 1.4542 (AISI 630)



BALL LOCK PINS & QUICK RELEASE PINS

Order No.	d ₁	l ₁	d ₂	d ₃	d ₄	l ₂	l ₃	l ₄	Loc'n hole tol. H11	Shearing resistance, double kN min.	Weight g
33060.W0312	8	10	9.6	39.2	18.5	8.2	33.3	13.4	8	38	38
33060.W0313	8	15	9.6	39.2	18.5	8.2	33.3	13.4	8	38	58
33060.W0314	8	20	9.6	39.2	19.3	8.2	33.3	13.4	8	63	40
33060.W0315	8	25	9.6	39.2	19.3	8.2	33.3	13.4	8	63	42
33060.W0316	8	30	9.6	39.2	19.3	8.2	33.3	13.4	8	63	44
33060.W0317	8	35	9.6	39.2	19.3	8.2	33.3	13.4	8	63	46
33060.W0318	8	40	9.6	39.2	19.3	8.2	33.3	13.4	8	63	47
33060.W0319	8	45	9.6	39.2	19.3	8.2	33.3	13.4	8	63	49
33060.W0320	8	50	9.6	39.2	19.3	8.2	33.3	13.4	8	63	51
33060.W0321	8	50	9.6	39.2	19.3	8.2	33.3	13.4	8	63	51
33060.W0322	8	50	9.6	39.2	19.3	8.2	33.3	13.4	8	63	51
33060.W0323	8	80	9.6	39.2	18.4	8.2	33.3	13.4	8	38	69
33060.W0324	10	20	12.0	39.2	19.3	9.6	33.3	13.4	10	100	47
33060.W0325	10	25	12.0	39.2	19.3	9.6	33.3	13.4	10	100	49
33060.W0326	10	30	12.0	39.2	19.3	9.6	33.3	13.4	10	100	53
33060.W0327	10	35	12.0	39.2	19.3	9.6	33.3	13.4	10	100	55
33060.W0328	10	40	12.0	39.2	19.3	9.6	33.3	13.4	10	100	58
33060.W0329	10	45	12.0	39.2	19.3	9.6	33.3	13.4	10	100	61
33060.W0330	10	50	12.0	39.2	19.3	9.6	33.3	13.4	10	100	64
33060.W0331	10	15	12.0	39.2	18.4	9.6	33.3	13.4	10	60	86
33060.W0332	10	60	12.0	39.2	19.3	9.6	33.3	13.4	10	100	70
33060.W0333	10	91	12.0	39.2	18.4	9.6	33.3	13.4	10	60	70
33060.W0334	10	80	12.0	39.2	18.4	9.6	33.3	13.4	10	60	97
33060.W0335	10	90	12.0	39.2	18.4	9.6	33.3	13.4	10	60	103
33060.W0336	10	100	12.0	39.2	18.4	9.6	33.3	13.4	10	60	109
33060.W0337	10	110	12.0	39.2	18.4	9.6	33.3	13.4	10	60	115
33060.W0338	10	120	12.0	39.2	18.4	9.6	33.3	13.4	10	60	53
33060.W0339	12	20	14.5	47.6	25.2	10.6	39.7	16.7	12	87	156
33060.W0344	12	20	14.5	47.6	26.3	10.6	39.7	16.7	12	87	156
33060.W0345	12	25	14.5	47.6	26.3	10.6	39.7	16.7	12	144	96
33060.W0346	12	30	14.5	47.6	26.3	10.6	39.7	16.7	12	144	100
33060.W0347	12	35	14.5	47.6	26.3	10.6	39.7	16.7	12	144	105
33060.W0348	12	40	14.5	47.6	26.3	10.6	39.7	16.7	12	144	109
33060.W0349	12	45	14.5	47.6	26.3	10.6	39.7	16.7	12	144	113
33060.W0350	12	50	14.5	47.6	26.3	10.6	39.7	16.7	12	144	117
33060.W0352	12	60	14.5	47.6	26.3	10.6	39.7	16.7	12	144	126
33060.W0354	12	70	14.5	47.6	26.3	10.6	39.7	16.7	12	144	134
33060.W0356	12	80	14.5	47.6	26.3	10.6	39.7	16.7	12	144	143
33060.W0357	12	90	14.5	47.6	25.2	10.6	39.7	16.7	12	87	165
33060.W0358	12	100	14.5	47.6	25.2	10.6	39.7	16.7	12	87	173
33060.W0359	12	110	14.5	47.6	25.2	10.6	39.7	16.7	12	87	182
33060.W0360	12	120	14.5	47.6	25.2	10.6	39.7	16.7	12	87	96
33060.W0366	16	30	19.0	47.6	26.3	14.0	39.7	16.7	16	257	132
33060.W0367	16	35	19.0	47.6	26.3	14.0	39.7	16.7	16	257	140
33060.W0368	16	40	19.0	47.6	26.3	14.0	39.7	16.7	16	257	148
33060.W0369	16	45	19.0	47.6	26.3	14.0	39.7	16.7	16	257	155
33060.W0370	16	50	19.0	47.6	26.3	14.0	39.7	16.7	16	257	168
33060.W0372	16	60	19.0	47.6	26.3	14.0	39.7	16.7	16	257	178
33060.W0374	16	70	19.0	47.6	26.3	14.0	39.7	16.7	16	257	194
33060.W0376	16	80	19.0	47.6	26.3	14.0	39.7	16.7	16	257	208
33060.W0377	16	90	19.0	47.6	25.2	14.0	39.7	16.7	16	155	234
33060.W0378	16	100	19.0	47.6	25.2	14.0	39.7	16.7	16	155	251
33060.W0379	16	110	19.0	47.6	25.2	14.0	39.7	16.7	16	155	266
33060.W0380	16	120	19.0	47.6	25.2	14.0	39.7	16.7	16	155	281
33060.W0381	16	130	19.0	47.6	25.2	14.0	39.7	16.7	16	155	297
33060.W0382	16	140	19.0	47.6	25.2	14.0	39.7	16.7	16	155	313
33060.W0383	16	150	19.0	47.6	25.2	14.0	39.7	16.7	16	155	328
33060.W0391	20	50	25.0	57.1	33.8	20.5	50.7	21.5	20	403	329
33060.W0392	20	60	25.0	57.1	35.4	20.5	50.7	21.5	20	403	343
33060.W0393	20	90	25.0	57.1	33.8	20.5	50.7	21.5	20	403	377
33060.W0396	20	80	25.0	57.1	35.4	20.5	50.7	21.5	20	403	392
33060.W0397	20	90	25.0	57.1	33.8	20.5	50.7	21.5	20	403	426
33060.W0400	20	100	25.0	57.1	35.4	20.5	50.7	21.5	20	403	440
33060.W0401	20	110	25.0	57.1	33.8	20.5	50.7	21.5	20	403	474
33060.W0404	20	120	25.0	57.1	35.4	20.5	50.7	21.5	20	403	488
33060.W0405	20	130	25.0	57.1	33.8	20.5	50.7	21.5	20	403	523
33060.W0406	20	140	25.0	57.1	33.8	20.5	50.7	21.5	20	403	546



Ball Lock Pins - Single Acting - Grey

self-locking - stainless steel 1.4542 (AISI 630)

Ball Lock Pins & Quick Release



Order No.	d ₁	l ₁	d ₂	d ₃	d ₄	l ₂	l ₃	l ₄	Loc'n hole tol. H11	Shearing resistance, double kN min.	Weight g
33060.W0407	20	150	25.0	57.1	33.8	20.5	50.7	21.5	20	403	571
33060.W0409	25	50	30.8	57.1	33.8	22.0	50.7	21.5	25	631	415
33060.W0410	25	60	30.8	57.1	33.8	22.0	50.7	21.5	25	631	453
33060.W0411	25	70	30.8	57.1	33.8	22.0	50.7	21.5	25	631	490
33060.W0412	25	80	30.8	57.1	33.8	22.0	50.7	21.5	25	631	528
33060.W0413	25	90	30.8	57.1	33.8	22.0	50.7	21.5	25	631	565
33060.W0414	25	100	30.8	57.1	33.8	22.0	50.7	21.5	25	631	603
33060.W0415	25	110	30.8	57.1	33.8	22.0	50.7	21.5	25	631	640
33060.W0416	25	120	30.8	57.1	33.8	22.0	50.7	21.5	25	631	678
33060.W0417	25	130	30.8	57.1	33.8	22.0	50.7	21.5	25	631	715
33060.W0418	25	140	30.8	57.1	33.8	22.0	50.7	21.5	25	631	753
33060.W0419	25	150	30.8	57.1	33.8	22.0	50.7	21.5	25	631	790

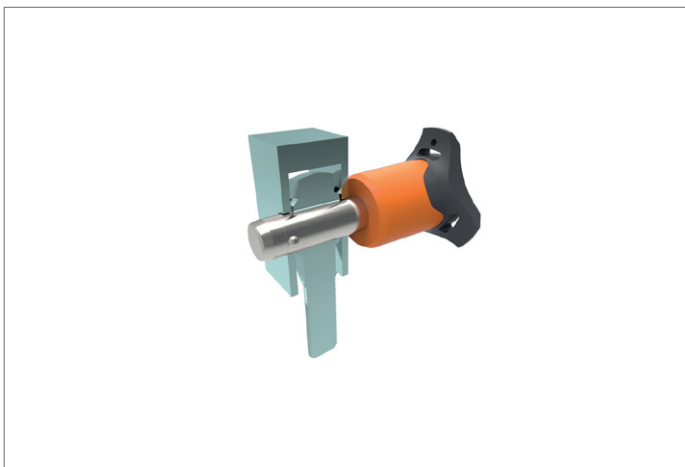

BALL LOCK PINS & QUICK RELEASE PINS

Ball Lock Pins & Quick Release

Ball Lock Pins - Single Acting - Orange

self-locking - stainless steel 1.4542 (AISI 630)



BALL LOCK PINS & QUICK RELEASE PINS



33060.OR

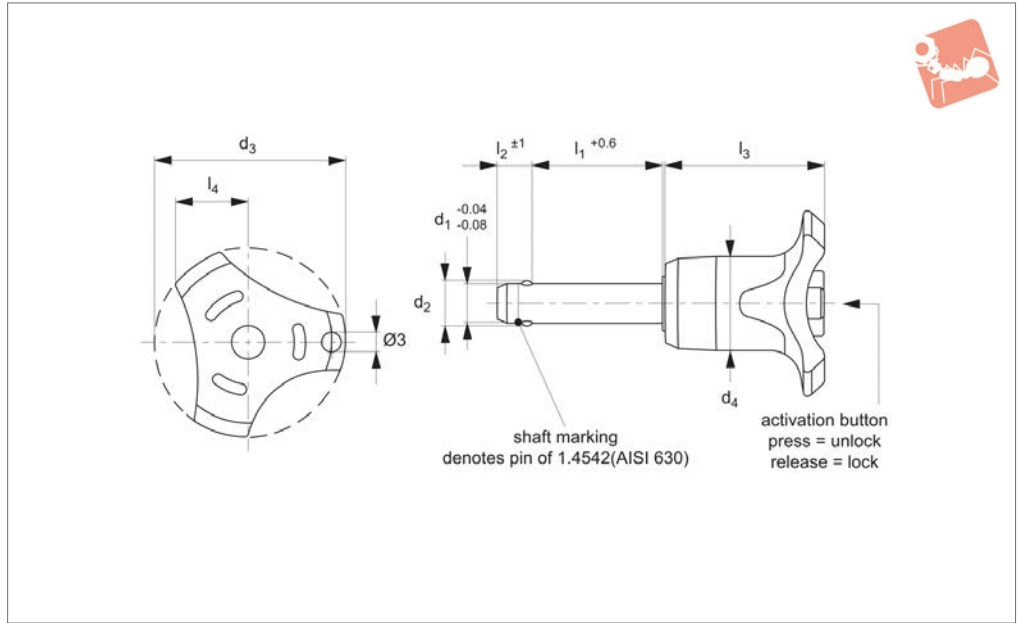

Material

Pin: stainless steel 1,4542 (AISI 630), precipitation hardened, blast finish. (marked at end of shaft to denote 1.4542 material).

Ball: stainless steel 1.3541

Spring: stainless steel.

Handle: thermoplastic PA 6.

Available colours: grey/orange, grey/blue, grey/grey, black/black.

Technical Notes

Pressing = unlocking.

Releasing = locking.

Temperature resistance -30°C to +80°C.

For quick fastening and locking of frequently repeated connections.

Tips

For lanyards & retaining cables see part no.33250. Easy install locating bushes

available see part no.33248.

Important Notes

Extreme load capacity due to high material grade.

*Shearing resistance similar to DIN 50141.

Also available in stainless grade 1.4305 (AISI 303), see part no.33080.

Order No.	d ₁	l ₁	d ₂	d ₃	d ₄	l ₂	l ₃	l ₄	Loc'n hole tol. H11	Shearing resistance, double kN min.	Weight g
33060.W0152	5	10	5.5	33.2	14.5	6.0	26.7	10.8	5	24	15
33060.W0153	5	15	5.5	33.2	14.5	6.0	26.7	10.8	5	24	15
33060.W0154	5	20	5.5	33.2	14.5	6.0	26.7	10.8	5	24	16
33060.W0155	5	25	5.5	33.2	14.5	6.0	26.7	10.8	5	24	17
33060.W0156	5	30	5.5	33.2	14.5	6.0	26.7	10.8	5	24	18
33060.W0157	6	60	7.0	33.2	14.5	7.0	26.7	10.8	6	21	26
33060.W0158	6	70	7.0	33.2	14.5	7.0	26.7	10.8	6	21	28
33060.W0159	6	80	7.0	33.2	14.5	7.0	26.7	10.8	6	21	30
33060.W0145	5	35	5.5	33.2	14.5	6.0	26.7	10.8	5	14	19
33060.W0146	5	40	5.5	33.2	14.5	6.0	26.7	10.8	5	14	20
33060.W0147	5	45	5.5	33.2	14.5	6.0	26.7	10.8	5	14	21
33060.W0148	5	50	5.5	33.2	14.5	6.0	26.7	10.8	5	14	23
33060.W0149	5	60	5.5	33.2	14.5	6.0	26.7	10.8	5	14	24
33060.W0150	5	70	5.5	33.2	14.5	6.0	26.7	10.8	5	14	18
33060.W0151	5	80	5.5	33.2	14.5	6.0	26.7	10.8	5	14	19
33060.W0161	8	100	9.6	39.2	18.4	8.2	33.3	13.4	8	38	54
33060.W0162	6	10	7.0	33.2	14.5	7.0	26.7	10.8	6	35	16
33060.W0163	6	15	7.0	33.2	14.5	7.0	26.7	10.8	6	35	17
33060.W0164	6	20	7.0	33.2	14.5	7.0	26.7	10.8	6	35	18
33060.W0165	6	25	7.0	33.2	14.5	7.0	26.7	10.8	6	35	19
33060.W0166	6	30	7.0	33.2	14.5	7.0	26.7	10.8	6	35	20
33060.W0167	6	35	7.0	33.2	14.5	7.0	26.7	10.8	6	35	21
33060.W0168	6	40	7.0	33.2	14.5	7.0	26.7	10.8	6	35	22
33060.W0169	6	45	7.0	33.2	14.5	7.0	26.7	10.8	6	35	23
33060.W0170	6	50	7.0	33.2	14.5	7.0	26.7	10.8	6	35	24
33060.W0171	8	90	9.6	39.2	18.4	8.2	33.3	13.4	8	38	36

Ball Lock Pins & Quick Release

Ball Lock Pins - Single Acting - Orange

self-locking - stainless steel 1.4542 (AISI 630)



BALL LOCK PINS & QUICK RELEASE PINS

Order No.	d ₁	l ₁	d ₂	d ₃	d ₄	l ₂	l ₃	l ₄	Loc'n hole tol. H11	Shearing resistance, double kN min.	Weight g
33060.W0269	25	50	30.8	57.1	33.8	22.0	50.7	21.5	25	631	415
33060.W0270	25	60	30.8	57.1	33.8	22.0	50.7	21.5	25	631	453
33060.W0271	25	70	30.8	57.1	33.8	22.0	50.7	21.5	25	631	490
33060.W0272	25	80	30.8	57.1	33.8	22.0	50.7	21.5	25	631	528
33060.W0273	25	90	30.8	57.1	33.8	22.0	50.7	21.5	25	631	565
33060.W0274	25	100	30.8	57.1	33.8	22.0	50.7	21.5	25	631	603
33060.W0275	25	110	30.8	57.1	33.8	22.0	50.7	21.5	25	631	640
33060.W0276	25	120	30.8	57.1	33.8	22.0	50.7	21.5	25	631	678
33060.W0277	25	130	30.8	57.1	33.8	22.0	50.7	21.5	25	631	715
33060.W0278	25	140	30.8	57.1	33.8	22.0	50.7	21.5	25	631	753
33060.W0279	25	150	30.8	57.1	33.8	22.0	50.7	21.5	25	631	790

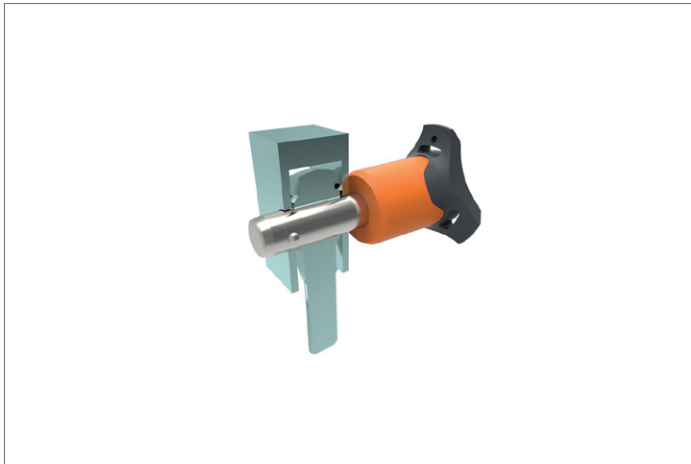



Ball Lock Pins - Single Acting - Black

self-locking - stainless steel 1.4305 (AISI 303)

Ball Lock Pins & Quick Release

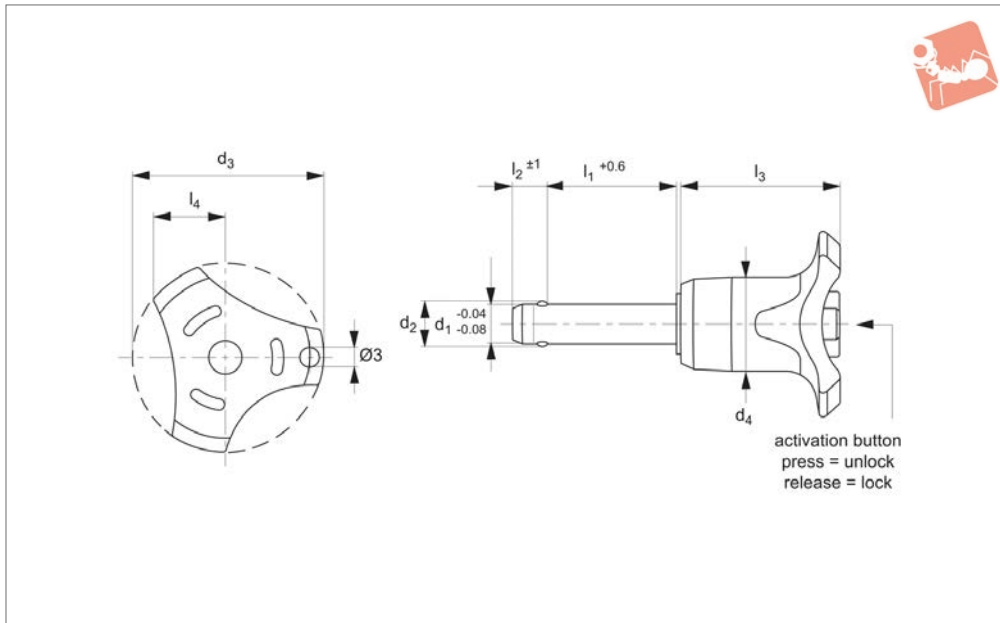

33080.BK

BALL LOCK PINS & QUICK RELEASE PINS

Material

Pin: stainless steel 1.4542 (AISI 630)
 Ball: stainless steel 1.3541
 Spring: stainless steel.
 Handle: thermoplastic PA 6.
 Available colours: grey/orange, grey/blue,
 grey/grey.

Technical Notes

Pressing = unlocking.

Releasing = locking.

Temperature resistance -30°C to +80°C.
 For quick fastening and locking of
 frequently repeated connections.

Tips

For lanyards & retaining cables see part
 no.33250-33261. Easy install locating
 bushes available see part no.33248 +
 33246.

Important Notes

*Shearing resistance similar to DIN 50141.
 Also available in stainless grade 1.4542
 (AISI 630) for higher shear forces, see part
 no.33060.

Order No.	d ₁	l ₁	d ₂	d ₃	d ₄	l ₂	l ₃	l ₄	Loc'n hole tol. H11	Shearing resistance, double kN min.	Weight g
33080.W0812	5	10	5.5	33.2	14.5	6.0	26.7	10.8	5	14	15
33080.W0813	5	15	5.5	33.2	14.5	6.0	26.7	10.8	5	14	15
33080.W0814	5	20	5.5	33.2	14.5	6.0	26.7	10.8	5	14	16
33080.W0815	5	20	5.5	33.2	14.5	6.0	26.7	10.8	5	14	16
33080.W0816	5	30	5.5	33.2	14.5	6.0	26.7	10.8	5	14	18
33080.W0817	6	60	7.0	33.2	14.5	7.0	26.7	10.8	6	21	26
33080.W0818	6	70	7.0	33.2	14.5	7.0	26.7	10.8	6	21	28
33080.W0819	6	80	7.0	33.2	14.5	7.0	26.7	10.8	6	21	30
33080.W0832	8	10	9.6	39.2	18.4	8.2	33.3	13.4	8	38	38
33080.W0833	8	15	9.6	39.2	18.4	8.2	33.3	13.4	8	38	58
33080.W0805	5	35	5.5	33.2	14.5	6.0	26.7	10.8	5	14	19
33080.W0806	5	40	5.5	33.2	14.5	6.0	26.7	10.8	5	14	20
33080.W0807	5	45	5.5	33.2	14.5	6.0	26.7	10.8	5	14	21
33080.W0808	5	50	5.5	33.2	14.5	6.0	26.7	10.8	5	14	23
33080.W0809	5	60	5.5	33.2	14.5	6.0	26.7	10.8	5	14	24
33080.W0810	5	70	5.5	33.2	14.5	6.0	26.7	10.8	5	14	18
33080.W0811	5	80	5.5	33.2	14.5	6.0	26.7	10.8	5	14	19
33080.W0822	6	10	7.0	33.2	14.5	7.0	26.7	10.8	6	21	16
33080.W0823	6	15	7.0	33.2	14.5	7.0	26.7	10.8	6	21	17
33080.W0824	6	20	7.0	33.2	14.5	7.0	26.7	10.8	6	21	18
33080.W0825	6	25	7.0	33.2	14.5	7.0	26.7	10.8	6	21	19
33080.W0826	6	30	7.0	33.2	14.5	7.0	26.7	10.8	6	21	20
33080.W0827	6	35	7.0	33.2	14.5	7.0	26.7	10.8	6	21	21
33080.W0828	6	35	7.0	33.2	14.5	7.0	26.7	10.8	6	21	21
33080.W0829	6	45	7.0	33.2	14.5	7.0	26.7	10.8	6	21	23
33080.W0830	6	50	7.0	33.2	14.5	7.0	26.7	10.8	6	21	24
33080.W0834	8	20	9.6	39.2	19.3	8.2	33.3	13.4	8	38	40



Ball Lock Pins - Single Acting - Black

self-locking - stainless steel 1.4305 (AISI 303)

Ball Lock Pins & Quick Release



Order No.	d ₁	l ₁	d ₂	d ₃	d ₄	l ₂	l ₃	l ₄	Loc'n hole tol. H11	Shearing resistance, double kN min.	Weight g
33080.W0922	25	60	30.8	57.1	33.8	22.0	50.7	21.5	25	386	453
33080.W0923	25	70	30.8	57.1	33.8	22.0	50.7	21.5	25	386	490
33080.W0924	25	80	30.8	57.1	33.8	22.0	50.7	21.5	25	386	528
33080.W0925	25	90	30.8	57.1	33.8	22.0	50.7	21.5	25	386	565
33080.W0926	25	100	30.8	57.1	33.8	22.0	50.7	21.5	25	386	603
33080.W0927	25	110	30.8	57.1	33.8	22.0	50.7	21.5	25	386	640
33080.W0928	25	120	30.8	57.1	33.8	22.0	50.7	21.5	25	386	690
33080.W0929	25	130	30.8	57.1	33.8	22.0	50.7	21.5	25	386	715
33080.W0930	25	140	30.8	57.1	33.8	22.0	50.7	21.5	25	386	753
33080.W0931	25	150	30.8	57.1	33.8	22.0	50.7	21.5	25	386	790

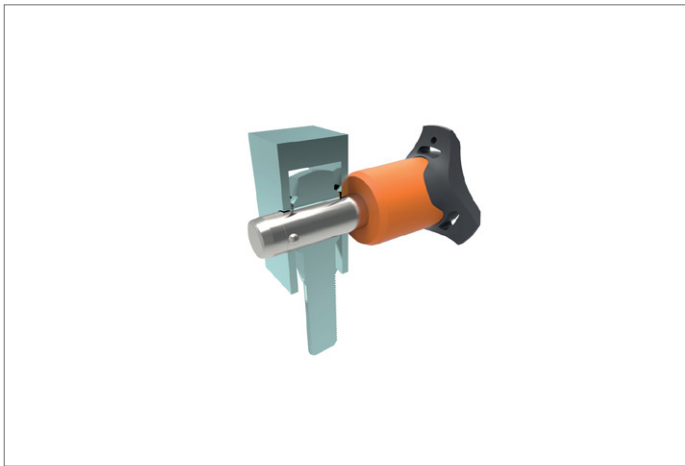

BALL LOCK PINS & QUICK RELEASE PINS



33080.BU

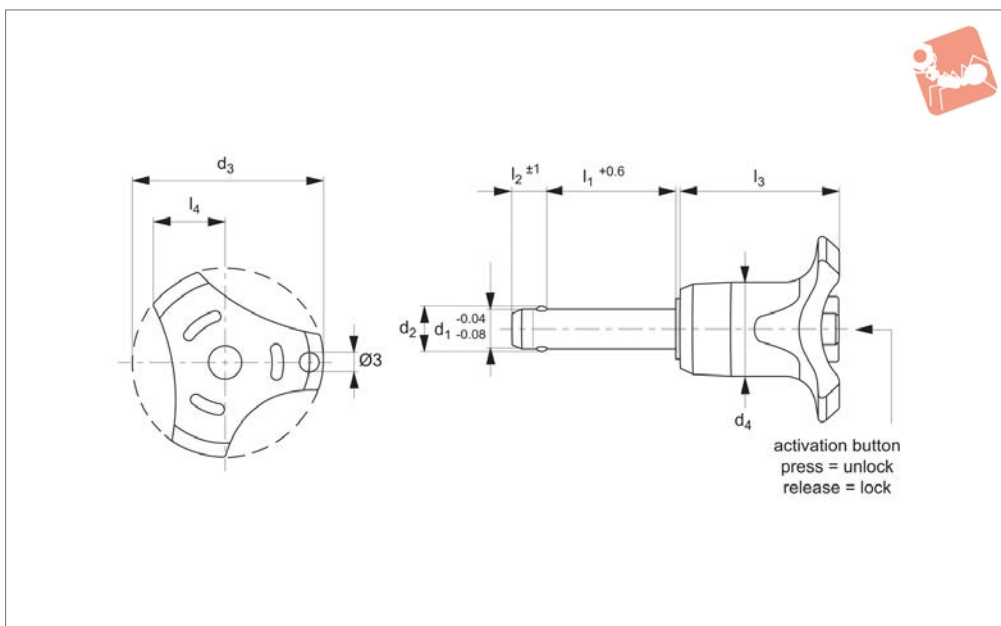

Material

Pin: stainless steel 1.4542 (AISI 630)
 Ball: stainless steel 1.3541
 Spring: stainless steel.
 Handle: thermoplastic PA 6.
 Available colours: grey/orange, grey/blue, grey/grey.

Technical Notes

Pressing = unlocking.

Releasing = locking.

Temperature resistance -30°C to +80°C.
 For quick fastening and locking of frequently repeated connections.

Tips

For lanyards & retaining cables see part no.33250-33261. Easy install locating bushes available see part no.33248 + 33246.

Important Notes

*Shearing resistance similar to DIN 50141.
 Also available in stainless grade 1.4542 (AISI 630) for higher shear forces, see part no.33060.

Order No.	d ₁	l ₁	d ₂	d ₃	d ₄	l ₂	l ₃	l ₄	Loc'n hole tol. H11	Shearing resistance, double kN min.	Weight g
33080.W0432	5	10	5.5	33.2	14.5	6.0	26.7	10.8	5	14	15
33080.W0433	5	15	5.5	33.2	14.5	6.0	26.7	10.8	5	14	15
33080.W0434	5	20	5.5	33.2	14.5	6.0	26.7	10.8	5	14	16
33080.W0435	5	25	5.5	33.2	14.5	6.0	26.7	10.8	5	14	17
33080.W0436	5	30	5.5	33.2	14.5	6.0	26.7	10.8	5	14	18
33080.W0437	6	60	7.0	33.2	14.5	7.0	26.7	10.8	6	21	26
33080.W0438	6	70	7.0	33.2	14.5	7.0	26.7	10.8	6	21	28
33080.W0439	6	80	7.0	33.2	14.5	7.0	26.7	10.8	6	21	30
33080.W0425	5	35	5.5	33.2	14.5	6.0	26.7	10.8	5	14	19
33080.W0426	5	40	5.5	33.2	14.5	6.0	26.7	10.8	5	14	20
33080.W0427	5	45	5.5	33.2	14.5	6.0	26.7	10.8	5	14	21
33080.W0428	5	50	5.5	33.2	14.5	6.0	26.7	10.8	5	14	23
33080.W0429	5	60	5.5	33.2	14.5	6.0	26.7	10.8	5	14	24
33080.W0430	5	70	5.5	33.2	14.5	6.0	26.7	10.8	5	14	18
33080.W0431	5	80	5.5	33.2	14.5	6.0	26.7	10.8	5	14	19
33080.W0442	6	10	7.0	33.2	14.5	7.0	26.7	10.8	6	21	16
33080.W0443	6	15	7.0	33.2	14.5	7.0	26.7	10.8	6	21	17
33080.W0444	6	20	7.0	33.2	14.5	7.0	26.7	10.8	6	21	18
33080.W0445	6	25	7.0	33.2	14.5	7.0	26.7	10.8	6	21	19
33080.W0446	6	30	7.0	33.2	14.5	7.0	26.7	10.8	6	21	20
33080.W0447	6	35	7.0	33.2	14.5	7.0	26.7	10.8	6	21	21
33080.W0448	6	40	7.0	33.2	14.5	7.0	26.7	10.8	6	21	22
33080.W0449	6	45	7.0	33.2	14.5	7.0	26.7	10.8	6	21	23
33080.W0450	6	50	7.0	33.2	14.5	7.0	26.7	10.8	6	21	24
33080.W0452	8	10	9.6	39.2	18.4	8.2	33.3	13.4	8	38	38
33080.W0453	8	15	9.6	39.2	18.4	8.2	33.3	13.4	8	38	58
33080.W0454	8	20	9.6	39.2	19.3	8.2	33.3	13.4	8	38	40

Ball Lock Pins & Quick Release

Ball Lock Pins - Single Acting - Blue

self-locking - stainless steel 1.4305 (AISI 303)



Order No.	d ₁	l ₁	d ₂	d ₃	d ₄	l ₂	l ₃	l ₄	Loc'n hole tol. H11	Shearing resistance, double kN min.	Weight g
33080.W0551	25	70	30.8	57.1	33.8	22.0	50.7	21.5	25	386	490
33080.W0552	25	80	30.8	57.1	33.8	22.0	50.7	21.5	25	386	528
33080.W0553	25	90	30.8	57.1	33.8	22.0	50.7	21.5	25	386	565
33080.W0554	25	100	30.8	57.1	33.8	22.0	50.7	21.5	25	386	603
33080.W0556	25	120	30.8	57.1	33.8	22.0	50.7	21.5	25	386	690
33080.W0557	25	130	30.8	57.1	33.8	22.0	50.7	21.5	25	386	715
33080.W0558	25	140	30.8	57.1	33.8	22.0	50.7	21.5	25	386	753
33080.W0559	25	150	30.8	57.1	33.8	22.0	50.7	21.5	25	386	790

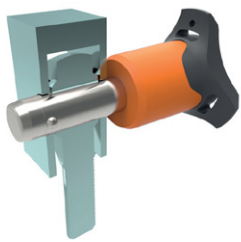

BALL LOCK PINS & QUICK RELEASE PINS

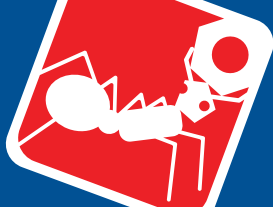

Ball Lock Pins - Single Acting - Grey

self-locking - stainless steel 1.4305 (AISI 303)

Ball Lock Pins & Quick Release

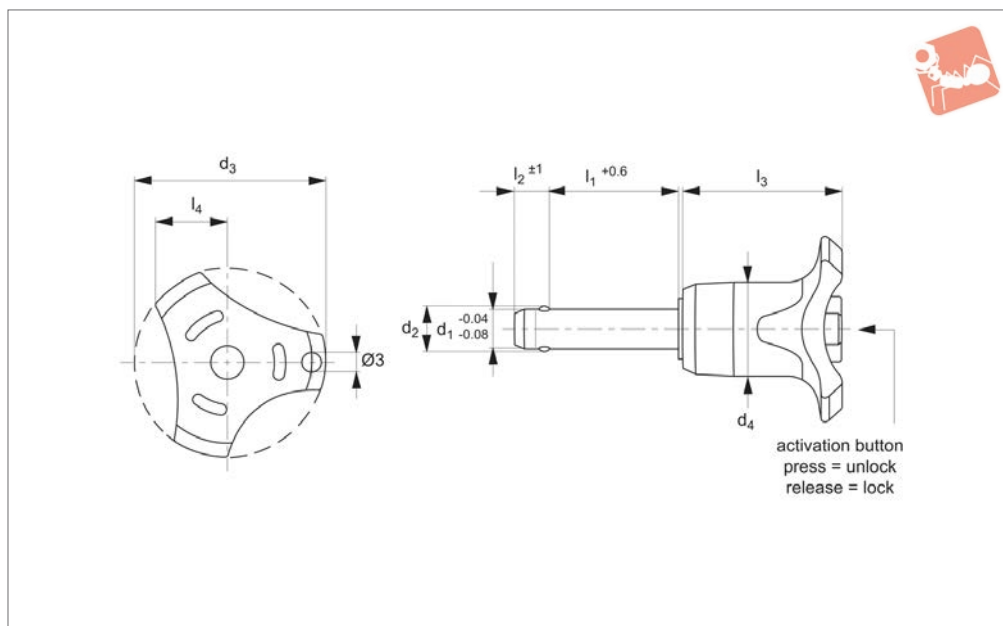

33080.GR

BALL LOCK PINS & QUICK RELEASE PINS

Material

Pin: stainless steel 1.4542 (AISI 630)
 Ball: stainless steel 1.3541
 Spring: stainless steel.
 Handle: thermoplastic PA 6.
 Available colours: grey/orange, grey/blue,
 grey/grey.

Technical Notes

Pressing = unlocking.

Releasing = locking.

Temperature resistance -30°C to +80°C.
 For quick fastening and locking of
 frequently repeated connections.

Tips

For lanyards & retaining cables see part
 no.33250-33261. Easy install locating
 bushes available see part no.33248 +
 33246.

Important Notes

*Shearing resistance similar to DIN 50141.
 Also available in stainless grade 1.4542
 (AISI 630) for higher shear forces, see part
 no.33060.

Order No.	d ₁	l ₁	d ₂	d ₃	d ₄	l ₂	l ₃	l ₄	Loc'n hole tol. H11	Shearing resistance, double kN min.	Weight g
33080.W0292	5	10	5.5	33.2	14.5	6.0	26.7	10.8	5	14	15
33080.W0293	5	15	5.5	33.2	14.5	6.0	26.7	10.8	5	14	15
33080.W0294	5	20	5.5	33.2	14.5	6.0	26.7	10.8	5	14	16
33080.W0295	5	25	5.5	33.2	14.5	6.0	26.7	10.8	5	14	17
33080.W0296	5	30	5.5	33.2	14.5	6.0	26.7	10.8	5	14	18
33080.W0297	6	60	7.0	33.2	14.5	7.0	26.7	10.8	6	21	26
33080.W0298	6	70	7.0	33.2	14.5	7.0	26.7	10.8	6	21	28
33080.W0299	6	80	7.0	33.2	14.5	7.0	26.7	10.8	6	21	30
33080.W0285	5	35	5.5	33.2	14.5	6.0	26.7	10.8	5	14	19
33080.W0286	5	40	5.5	33.2	14.5	6.0	26.7	10.8	5	14	20
33080.W0287	5	45	5.5	33.2	14.5	6.0	26.7	10.8	5	14	21
33080.W0288	5	50	5.5	33.2	14.5	6.0	26.7	10.8	5	14	23
33080.W0289	5	60	5.5	33.2	14.5	6.0	26.7	10.8	5	14	24
33080.W0290	5	70	5.5	33.2	14.5	6.0	26.7	10.8	5	14	18
33080.W0291	5	80	5.5	33.2	14.5	6.0	26.7	10.8	5	14	19
33080.W0302	6	10	7.0	33.2	14.5	7.0	26.7	10.8	6	21	16
33080.W0301	8	100	9.6	39.2	18.4	8.2	33.3	13.4	8	38	54
33080.W0303	6	15	7.0	33.2	14.5	7.0	26.7	10.8	6	21	17
33080.W0304	6	20	7.0	33.2	14.5	7.0	26.7	10.8	6	21	18
33080.W0305	6	25	7.0	33.2	14.5	7.0	26.7	10.8	6	21	19
33080.W0306	6	30	7.0	33.2	14.5	7.0	26.7	10.8	6	21	20
33080.W0307	6	35	7.0	33.2	14.5	7.0	26.7	10.8	6	21	21
33080.W0308	6	40	7.0	33.2	14.5	7.0	26.7	10.8	6	21	22
33080.W0309	6	45	7.0	33.2	14.5	7.0	26.7	10.8	6	21	23
33080.W0310	6	50	7.0	33.2	14.5	7.0	26.7	10.8	6	21	24
33080.W0311	8	90	9.6	39.2	18.4	8.2	33.3	13.4	8	38	36
33080.W0312	8	10	9.6	39.2	18.4	8.2	33.3	13.4	8	38	38



Ball Lock Pins - Single Acting - Grey

self-locking - stainless steel 1.4305 (AISI 303)

Ball Lock Pins & Quick Release



Order No.	d ₁	l ₁	d ₂	d ₃	d ₄	l ₂	l ₃	l ₄	Loc'n hole tol. H11	Shearing resistance, double kN min.	Weight g
33080.W0411	25	70	30.8	57.1	33.8	22.0	50.7	21.5	25	286	490
33080.W0412	25	80	30.8	57.1	33.8	22.0	50.7	21.5	25	286	528
33080.W0413	25	90	30.8	57.1	33.8	22.0	50.7	21.5	25	286	565
33080.W0414	25	100	30.8	57.1	33.8	22.0	50.7	21.5	25	286	603
33080.W0415	25	110	30.8	57.1	33.8	22.0	50.7	21.5	25	286	640
33080.W0416	25	120	30.8	57.1	33.8	22.0	50.7	21.5	25	286	690
33080.W0417	25	130	30.8	57.1	33.8	22.0	50.7	21.5	25	286	715
33080.W0418	25	140	30.8	57.1	33.8	22.0	50.7	21.5	25	286	753
33080.W0419	25	150	30.8	57.1	33.8	22.0	50.7	21.5	25	286	790

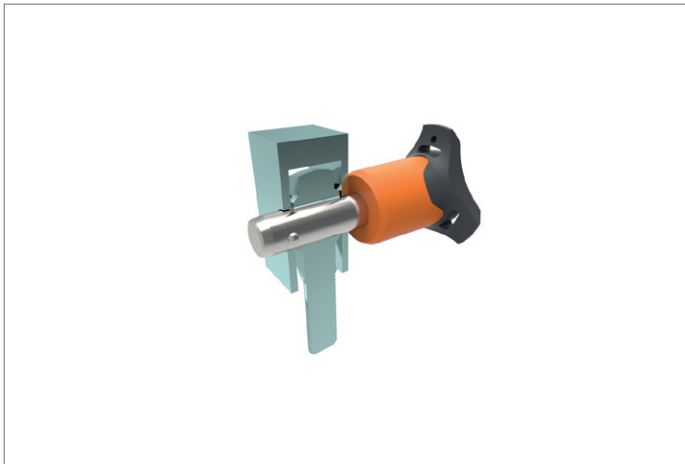

BALL LOCK PINS & QUICK RELEASE PINS



BALL LOCK PINS & QUICK RELEASE PINS



33080.OR

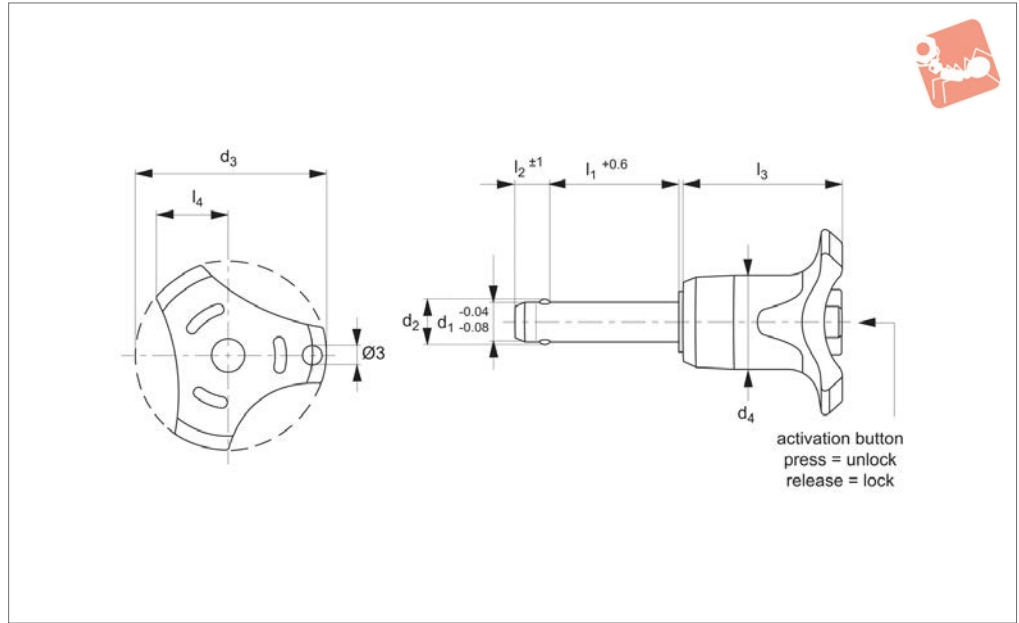

Material

Pin: stainless steel 1,4542 (AISI 630)
 Ball: stainless steel 1.3541
 Spring: stainless steel.
 Handle: thermoplastic PA 6.
 Available colours: grey/orange, grey/blue, grey/grey.

Technical Notes

Pressing = unlocking.

Releasing = locking.

Temperature resistance -30°C to +80°C.
 For quick fastening and locking of frequently repeated connections.

Tips

For lanyards & retaining cables see part no.33250-33261. Easy install locating bushes available see part no.33248 + 33246.

Important Notes

*Shearing resistance similar to DIN 50141.
 Also available in stainless grade 1.4542 (AISI 630) for higher shear forces, see part no.33060.

Order No.	d ₁	l ₁	d ₂	d ₃	d ₄	l ₂	l ₃	l ₄	Loc'n hole tol. H11	Shearing resistance, double kN min.	Weight g
33080.W0152	5	10	5.5	33.2	14.5	6.0	26.7	10.8	5	14	15
33080.W0153	5	15	5.5	33.2	14.5	6.0	26.7	10.8	5	14	15
33080.W0154	5	20	5.5	33.2	14.5	6.0	26.7	10.8	5	14	16
33080.W0155	5	25	5.5	33.2	14.5	6.0	26.7	10.8	5	14	17
33080.W0156	5	30	5.5	33.2	14.5	6.0	26.7	10.8	5	14	18
33080.W0157	6	60	7.0	33.2	14.5	7.0	26.7	10.8	6	21	26
33080.W0158	6	70	7.0	33.2	14.5	7.0	26.7	10.8	6	21	28
33080.W0159	6	80	7.0	33.2	14.5	7.0	26.7	10.8	6	21	30
33080.W0145	5	35	5.5	33.2	14.5	6.0	26.7	10.8	5	14	19
33080.W0146	5	40	5.5	33.2	14.5	6.0	26.7	10.8	5	14	20
33080.W0147	5	45	5.5	33.2	14.5	6.0	26.7	10.8	5	14	21
33080.W0148	5	50	5.5	33.2	14.5	6.0	26.7	10.8	5	14	23
33080.W0149	5	60	5.5	33.2	14.5	6.0	26.7	10.8	5	14	24
33080.W0150	5	70	5.5	33.2	14.5	6.0	26.7	10.8	5	14	18
33080.W0151	5	80	5.5	33.2	14.5	6.0	26.7	10.8	5	14	19
33080.W0161	8	100	9.6	39.2	18.4	8.2	33.3	13.4	8	38	54
33080.W0162	6	10	7.0	33.2	14.5	7.0	26.7	10.8	6	21	16
33080.W0163	6	15	7.0	33.2	14.5	7.0	26.7	10.8	6	21	17
33080.W0164	6	20	7.0	33.2	14.5	7.0	26.7	10.8	6	21	18
33080.W0165	6	25	7.0	33.2	14.5	7.0	26.7	10.8	6	21	19
33080.W0166	6	30	7.0	33.2	14.5	7.0	26.7	10.8	6	21	20
33080.W0167	6	35	7.0	33.2	14.5	7.0	26.7	10.8	6	21	21
33080.W0168	6	40	7.0	33.2	14.5	7.0	26.7	10.8	6	21	22
33080.W0169	6	45	7.0	33.2	14.5	7.0	26.7	10.8	6	21	23
33080.W0170	6	50	7.0	33.2	14.5	7.0	26.7	10.8	6	21	24
33080.W0171	8	90	9.6	39.2	18.4	8.2	33.3	13.4	8	38	36
33080.W0172	8	10	9.6	39.2	18.4	8.2	33.3	13.4	8	38	38

Ball Lock Pins & Quick Release

Ball Lock Pins - Single Acting - Orange self-locking - stainless steel 1.4305 (AISI 303)



BALL LOCK PINS & QUICK RELEASE PINS

Order No.	d ₁	l ₁	d ₂	d ₃	d ₄	l ₂	l ₃	l ₄	Loc'n hole tol. H11	Shearing resistance, double kN min.	Weight g
33080.W0270	25	60	30.8	57.1	33.8	22.0	50.7	21.5	25	386	453
33080.W0271	25	70	30.8	57.1	33.8	22.0	50.7	21.5	25	386	490
33080.W0272	25	80	30.8	57.1	33.8	22.0	50.7	21.5	25	386	528
33080.W0273	25	90	30.8	57.1	33.8	22.0	50.7	21.5	25	386	565
33080.W0274	25	100	30.8	57.1	33.8	22.0	50.7	21.5	25	386	603
33080.W0275	25	110	30.8	57.1	33.8	22.0	50.7	21.5	25	386	640
33080.W0276	25	120	30.8	57.1	33.8	22.0	50.7	21.5	25	386	690
33080.W0277	25	130	30.8	57.1	33.8	22.0	50.7	21.5	25	386	715
33080.W0278	25	140	30.8	57.1	33.8	22.0	50.7	21.5	25	386	753
33080.W0279	25	150	30.8	57.1	33.8	22.0	50.7	21.5	25	386	790

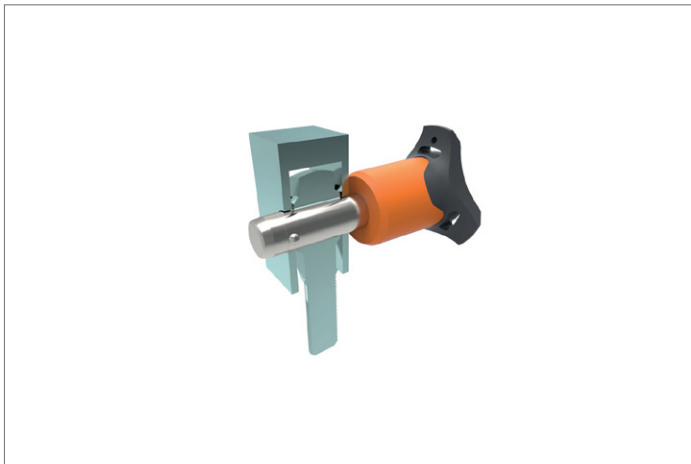



Ball Lock Pins - Single Acting

self-locking - adj. length - stainless 1.4305

Ball Lock Pins & Quick Release

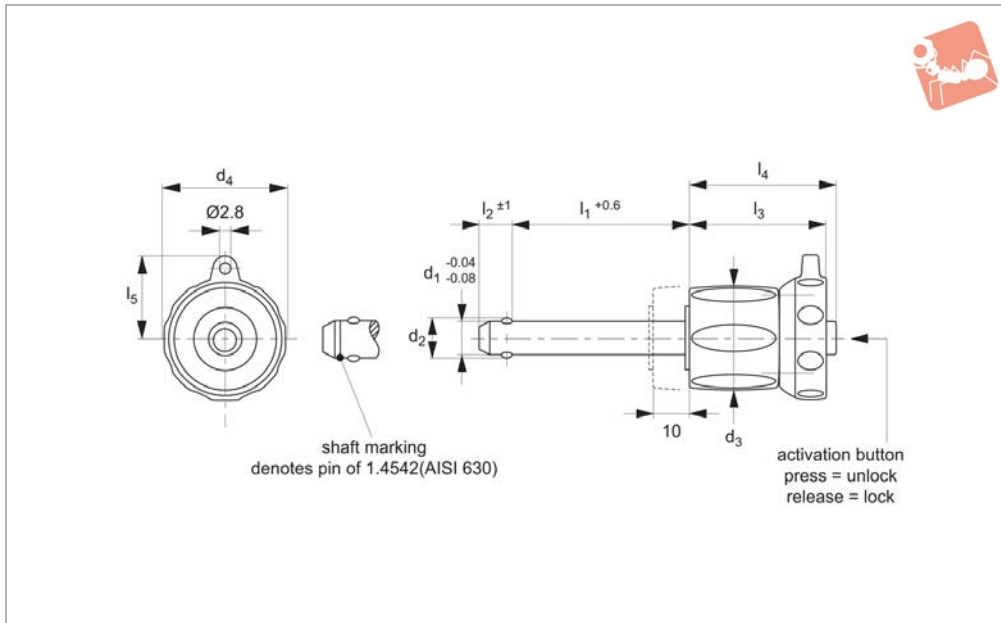

33104.1

BALL LOCK PINS & QUICK RELEASE PINS

Material

Pin: stainless steel 1.4305 (AISI 303).
Ball: stainless steel 1.3541
Spring: stainless steel.
Adj. Grip: thermoplastic, grey/black.

Technical Notes

Pressing = unlocking.
Releasing = locking.

Unique design; adj.grip offers up to 10mm of clamping stroke on pin length l_1 after installation.

Temperature resistance -30°C to +80°C.
For quick fastening and locking of frequently repeated connections, with additional clamping capacity of up to 10mm stroke.

Tips

For lanyards & retaining cables see part no.33250. Easy install locating bushes available see part no.33248.

Important Notes

*Shearing resistance similar to DIN 50141.

Order No.	d_1	l_1	Material	d_2	d_3	d_4	l_2	l_3	l_4	l_5	Loc'n hole tol. H11	Shearing resistance, double	Weight
												kN min.	g
33104.W0192	5	0 - 10	Stainless 1.4305	5.5	17.6	23.6	6.0	25.7	26.2	15.9	5	14	24
33104.W0193	5	5 - 15	Stainless 1.4305	5.5	17.6	23.6	6.0	25.7	26.2	15.9	5	14	25
33104.W0194	5	10 - 20	Stainless 1.4305	5.5	17.6	23.6	6.0	25.7	26.2	15.9	5	14	26
33104.W0195	5	15 - 25	Stainless 1.4305	5.5	17.6	23.6	6.0	25.7	26.2	15.9	5	14	27
33104.W0196	5	20 - 30	Stainless 1.4305	5.5	17.6	23.6	6.0	25.7	26.2	15.9	5	14	27
33104.W0202	6	0 - 10	Stainless 1.4305	7.0	17.6	23.6	7.0	25.7	26.2	15.9	6	21	25
33104.W0203	6	5 - 15	Stainless 1.4305	7.0	17.6	23.6	7.0	25.7	26.2	15.9	6	21	26
33104.W0204	6	10 - 20	Stainless 1.4305	7.0	17.6	23.6	7.0	25.7	26.2	15.9	6	21	27
33104.W0205	6	15 - 25	Stainless 1.4305	7.0	17.6	23.6	7.0	25.7	26.2	15.9	6	21	28
33104.W0206	6	20 - 30	Stainless 1.4305	7.0	17.6	23.6	7.0	25.7	26.2	15.9	6	21	29
33104.W0207	6	25 - 35	Stainless 1.4305	7.0	17.6	23.6	7.0	25.7	26.2	15.9	6	21	30
33104.W0208	6	30 - 40	Stainless 1.4305	7.0	17.6	23.6	7.0	25.7	26.2	15.9	6	21	31
33104.W0209	6	35 - 45	Stainless 1.4305	7.0	17.6	23.6	7.0	25.7	26.2	15.9	6	21	32
33104.W0210	6	40 - 50	Stainless 1.4305	7.0	17.6	23.6	7.0	25.7	26.2	15.9	6	21	33
33104.W0214	8	10 - 20	Stainless 1.4305	9.6	23.0	27.6	8.2	31.2	33.1	18.0	8	38	57
33104.W0215	8	15 - 25	Stainless 1.4305	9.6	23.0	27.6	8.2	31.2	33.1	18.0	8	38	58
33104.W0216	8	20 - 30	Stainless 1.4305	9.6	23.0	27.6	8.2	31.2	33.1	18.0	8	38	60
33104.W0217	8	25 - 35	Stainless 1.4305	9.6	23.0	27.6	8.2	31.2	33.1	18.0	8	38	62
33104.W0218	8	30 - 40	Stainless 1.4305	9.6	23.0	27.6	8.2	31.2	33.1	18.0	8	38	64
33104.W0219	8	35 - 45	Stainless 1.4305	9.6	23.0	27.6	8.2	31.2	33.1	18.0	8	38	66
33104.W0220	8	40 - 50	Stainless 1.4305	9.6	23.0	27.6	8.2	31.2	33.1	18.0	8	38	68
33104.W0224	10	10 - 20	Stainless 1.4305	12.0	23.0	27.6	9.6	31.2	33.1	18.0	10	60	63
33104.W0225	10	15 - 25	Stainless 1.4305	12.0	23.0	27.6	9.6	31.2	33.1	18.0	10	60	66
33104.W0226	10	20 - 30	Stainless 1.4305	12.0	23.0	27.6	9.6	31.2	33.1	18.0	10	60	69
33104.W0227	10	25 - 35	Stainless 1.4305	12.0	23.0	27.6	9.6	31.2	33.1	18.0	10	60	72
33104.W0228	10	30 - 40	Stainless 1.4305	12.0	23.0	27.6	9.6	31.2	33.1	18.0	10	60	75
33104.W0229	10	35 - 45	Stainless 1.4305	12.0	23.0	27.6	9.6	31.2	33.1	18.0	10	60	78
33104.W0230	10	40 - 50	Stainless 1.4305	12.0	23.0	27.6	9.6	31.2	33.1	18.0	10	60	81

Ball Lock Pins & Quick Release

Ball Lock Pins - Single Acting self-locking - adj. length - stainless 1.4305



BALL LOCK PINS & QUICK RELEASE PINS

Order No.	d ₁	l ₁	Material	d ₂	d ₃	d ₄	l ₂	l ₃	l ₄	l ₅	Loc'n hole tol. H11	Shearing resistance, double kN min.	Weight g
33104.W0232	10	50 - 60	Stainless 1.4305	12.0	23.0	27.6	9.6	31.2	33.1	18.0	10	60	87
33104.W0235	12	15 - 25	Stainless 1.4305	14.5	29.0	34.6	10.6	36.7	39.5	21.8	12	87	123
33104.W0236	12	20 - 30	Stainless 1.4305	14.5	29.0	34.6	10.6	36.7	39.5	21.8	12	87	127
33104.W0237	12	25 - 35	Stainless 1.4305	14.5	29.0	34.6	10.6	36.7	39.5	21.8	12	87	131
33104.W0238	12	30 - 40	Stainless 1.4305	14.5	29.0	34.6	10.6	36.7	39.5	21.8	12	87	135
33104.W0239	12	35 - 45	Stainless 1.4305	14.5	29.0	34.6	10.6	36.7	39.5	21.8	12	87	140
33104.W0240	12	40 - 50	Stainless 1.4305	14.5	29.0	34.6	10.6	36.7	39.5	21.8	12	87	144
33104.W0242	12	50 - 60	Stainless 1.4305	14.5	29.0	34.6	10.6	36.7	39.5	21.8	12	87	152
33104.W0244	12	60 - 70	Stainless 1.4305	14.5	29.0	34.6	10.6	36.7	39.5	21.8	12	87	161
33104.W0246	12	70 - 80	Stainless 1.4305	14.5	29.0	34.6	10.6	36.7	39.5	21.8	12	87	169
33104.W0256	16	20 - 30	Stainless 1.4305	19.0	29.0	34.6	14.0	36.7	39.5	21.8	16	155	159
33104.W0257	16	25 - 35	Stainless 1.4305	19.0	29.0	34.6	14.0	36.7	39.5	21.8	16	155	166
33104.W0258	16	30 - 40	Stainless 1.4305	19.0	29.0	34.6	14.0	36.7	39.5	21.8	16	155	174
33104.W0259	16	35 - 45	Stainless 1.4305	19.0	29.0	34.6	14.0	36.7	39.5	21.8	16	155	182
33104.W0260	16	40 - 50	Stainless 1.4305	19.0	29.0	34.6	14.0	36.7	39.5	21.8	16	155	189
33104.W0262	16	50 - 60	Stainless 1.4305	19.0	29.0	34.6	14.0	36.7	39.5	21.8	16	155	205
33104.W0264	16	60 - 70	Stainless 1.4305	19.0	29.0	34.6	14.0	36.7	39.5	21.8	16	155	220
33104.W0266	16	70 - 80	Stainless 1.4305	19.0	29.0	34.6	14.0	36.7	39.5	21.8	16	155	235

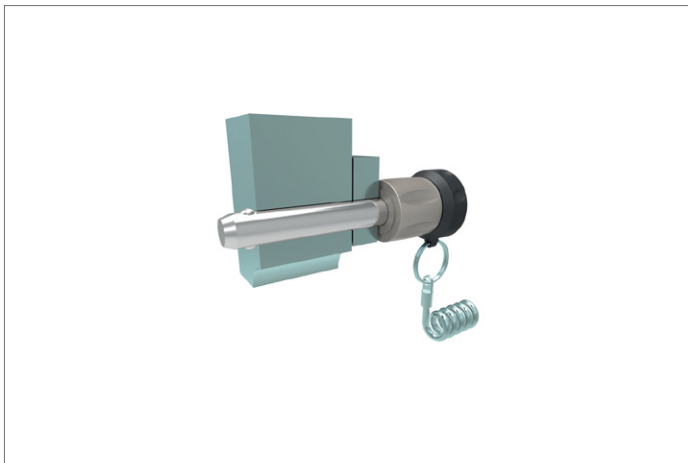



Ball Lock Pins - Single Acting

self-locking - adj. length - stainless 1.4542

Ball Lock Pins & Quick Release

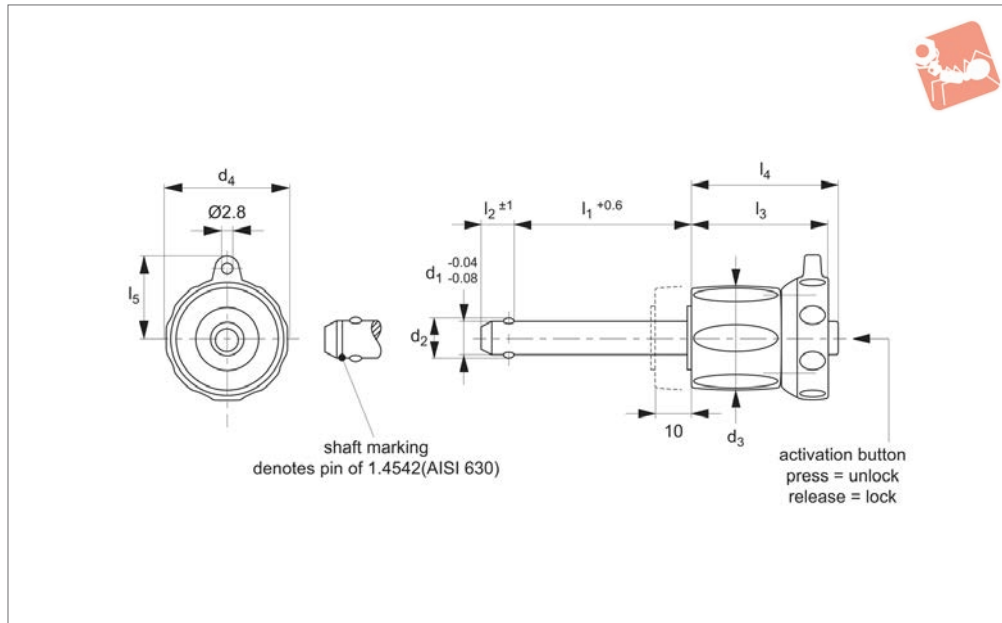

33104.2

BALL LOCK PINS & QUICK RELEASE PINS

Material

Pin: stainless steel 1.4542 (AISI 630), precipitation hardened, blast finish. Offering extreme load capacity. (Marked at end of shaft to denote 1.4542 material).
 Ball: stainless steel 1.3541
 Spring: stainless steel.
 Adj. Grip: thermoplastic, grey/black.

Releasing = locking.

Unique design; adj.grip offers up to 10mm of clamping stroke on pin length l_1 after installation.

Temperature resistance -30°C to +80°C.
 For quick fastening and locking of frequently repeated connections, with additional clamping capacity of up to 10mm stroke.

Tips

For lanyards & retaining cables see part no.33250. Easy install locating bushes available see part no.33248.

Important Notes

*Shearing resistance similar to DIN 50141.

Technical Notes

Pressing = unlocking.

Order No.	d_1	l_1	Material	d_2	d_3	d_4	l_2	l_3	l_4	l_5	Loc'n hole tol. H11	Shearing resistance, double	Weight
												kN min.	g
33104.W0392	5	0 - 10	Stainless 1.4542	5.5	17.6	23.6	6.0	25.7	26.2	15.9	5	24	24
33104.W0393	5	5 - 15	Stainless 1.4542	5.5	17.6	23.6	6.0	25.7	26.2	15.9	5	24	25
33104.W0394	5	10 - 20	Stainless 1.4542	5.5	17.6	23.6	6.0	25.7	26.2	15.9	5	24	26
33104.W0395	5	15 - 25	Stainless 1.4542	5.5	17.6	23.6	6.0	25.7	26.2	15.9	5	24	27
33104.W0396	5	20 - 30	Stainless 1.4542	5.5	17.6	23.6	6.0	25.7	26.2	15.9	5	24	27
33104.W0402	6	0 - 10	Stainless 1.4542	7.0	17.6	23.6	7.0	25.7	26.2	15.9	6	35	25
33104.W0403	6	5 - 15	Stainless 1.4542	7.0	17.6	23.6	7.0	25.7	26.2	15.9	6	35	26
33104.W0404	6	10 - 20	Stainless 1.4542	7.0	17.6	23.6	7.0	25.7	26.2	15.9	6	35	27
33104.W0405	6	15 - 25	Stainless 1.4542	7.0	17.6	23.6	7.0	25.7	26.2	15.9	6	35	28
33104.W0406	6	20 - 30	Stainless 1.4542	7.0	17.6	23.6	7.0	25.7	26.2	15.9	6	35	29
33104.W0407	6	25 - 35	Stainless 1.4542	7.0	17.6	23.6	7.0	25.7	26.2	15.9	6	35	30
33104.W0408	6	30 - 40	Stainless 1.4542	7.0	17.6	23.6	7.0	25.7	26.2	15.9	6	35	31
33104.W0409	6	35 - 45	Stainless 1.4542	7.0	17.6	23.6	7.0	25.7	26.2	15.9	6	35	32
33104.W0410	6	40 - 50	Stainless 1.4542	7.0	17.6	23.6	7.0	25.7	26.2	15.9	6	35	33
33104.W0414	8	10 - 20	Stainless 1.4542	9.6	23.0	27.6	8.2	31.2	33.1	18.0	8	63	57
33104.W0415	8	15 - 25	Stainless 1.4542	9.6	23.0	27.6	8.2	31.2	33.1	18.0	8	63	58
33104.W0416	8	20 - 30	Stainless 1.4542	9.6	23.0	27.6	8.2	31.2	33.1	18.0	8	63	60
33104.W0417	8	25 - 35	Stainless 1.4542	9.6	23.0	27.6	8.2	31.2	33.1	18.0	8	63	62
33104.W0418	8	30 - 40	Stainless 1.4542	9.6	23.0	27.6	8.2	31.2	33.1	18.0	8	63	64
33104.W0419	8	35 - 45	Stainless 1.4542	9.6	23.0	27.6	8.2	31.2	33.1	18.0	8	63	66
33104.W0420	8	40 - 50	Stainless 1.4542	9.6	23.0	27.6	8.2	31.2	33.1	18.0	8	63	68
33104.W0424	10	10 - 20	Stainless 1.4542	12.0	23.0	27.6	9.6	31.2	33.1	18.0	10	100	63
33104.W0425	10	15 - 25	Stainless 1.4542	12.0	23.0	27.6	9.6	31.2	33.1	18.0	10	100	66
33104.W0426	10	20 - 30	Stainless 1.4542	12.0	23.0	27.6	9.6	31.2	33.1	18.0	10	100	69
33104.W0427	10	25 - 35	Stainless 1.4542	12.0	23.0	27.6	9.6	31.2	33.1	18.0	10	100	72

Ball Lock Pins & Quick Release

Ball Lock Pins - Single Acting

self-locking - adj. length - stainless 1.4542



BALL LOCK PINS & QUICK RELEASE PINS

Order No.	d ₁	l ₁	Material	d ₂	d ₃	d ₄	l ₂	l ₃	l ₄	l ₅	Loc'n hole tol. H11	Shearing resistance, double kN min.	Weight g
33104.W0428	10	30 - 40	Stainless 1.4542	12.0	23.0	27.6	9.6	31.2	33.1	18.0	10	100	75
33104.W0429	10	35 - 45	Stainless 1.4542	12.0	23.0	27.6	9.6	31.2	33.1	18.0	10	100	78
33104.W0430	10	40 - 50	Stainless 1.4542	12.0	23.0	27.6	9.6	31.2	33.1	18.0	10	100	81
33104.W0432	10	50 - 60	Stainless 1.4542	12.0	23.0	27.6	9.6	31.2	33.1	18.0	10	100	87
33104.W0435	12	15 - 25	Stainless 1.4542	14.5	29.0	34.6	10.6	36.7	39.5	21.8	12	144	123
33104.W0436	12	20 - 30	Stainless 1.4542	14.5	29.0	34.6	10.6	36.7	39.5	21.8	12	144	127
33104.W0437	12	25 - 35	Stainless 1.4542	14.5	29.0	34.6	10.6	36.7	39.5	21.8	12	144	131
33104.W0438	12	30 - 40	Stainless 1.4542	14.5	29.0	34.6	10.6	36.7	39.5	21.8	12	144	135
33104.W0439	12	35 - 45	Stainless 1.4542	14.5	29.0	34.6	10.6	36.7	39.5	21.8	12	144	140
33104.W0440	12	40 - 50	Stainless 1.4542	14.5	29.0	34.6	10.6	36.7	39.5	21.8	12	144	144
33104.W0442	12	50 - 60	Stainless 1.4542	14.5	29.0	34.6	10.6	36.7	39.5	21.8	12	144	152
33104.W0444	12	60 - 70	Stainless 1.4542	14.5	29.0	34.6	10.6	36.7	39.5	21.8	12	144	161
33104.W0446	12	70 - 80	Stainless 1.4542	14.5	29.0	34.6	10.6	36.7	39.5	21.8	12	144	169
33104.W0456	16	20 - 30	Stainless 1.4542	19.0	29.0	34.6	14.0	36.7	39.5	21.8	16	257	159
33104.W0457	16	25 - 35	Stainless 1.4542	19.0	29.0	34.6	14.0	36.7	39.5	21.8	16	257	166
33104.W0458	16	30 - 40	Stainless 1.4542	19.0	29.0	34.6	14.0	36.7	39.5	21.8	16	257	174
33104.W0459	16	35 - 45	Stainless 1.4542	19.0	29.0	34.6	14.0	36.7	39.5	21.8	16	257	182
33104.W0460	16	40 - 50	Stainless 1.4542	19.0	29.0	34.6	14.0	36.7	39.5	21.8	16	257	189
33104.W0462	16	50 - 60	Stainless 1.4542	19.0	29.0	34.6	14.0	36.7	39.5	21.8	16	257	205
33104.W0464	16	60 - 70	Stainless 1.4542	19.0	29.0	34.6	14.0	36.7	39.5	21.8	16	257	220
33104.W0466	16	70 - 80	Stainless 1.4542	19.0	29.0	34.6	14.0	36.7	39.5	21.8	16	257	235

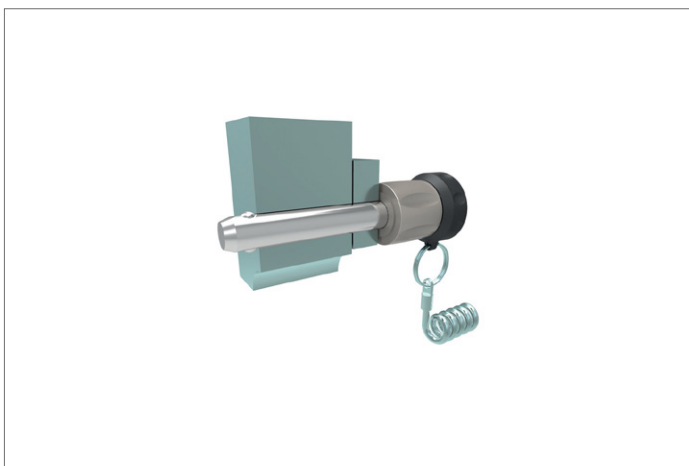



Wixroyd Ball Lock Pins

applications

33060 - 33250
Positioning Elements



Sound Rigging Systems

Ball lock pins on a sound rigging system. Offering secure fixing with high shear forces and easy fitting for operators at heights.

In addition full black powder coating of grip and actuation button eliminates glare from other stage lighting.

BALL LOCK PINS & QUICK RELEASE PINS

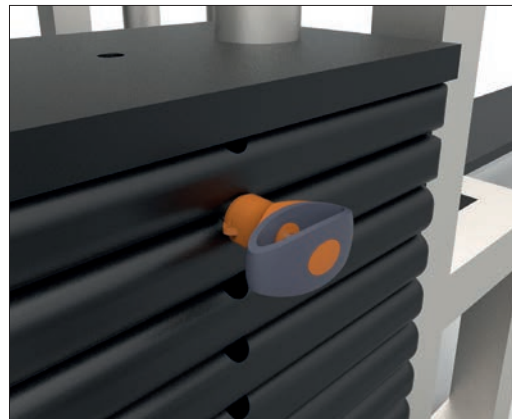
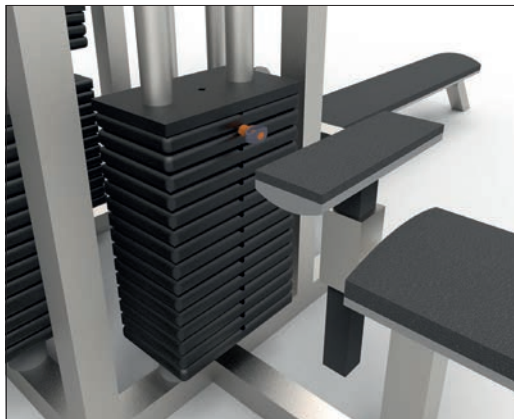

Gym Equipment

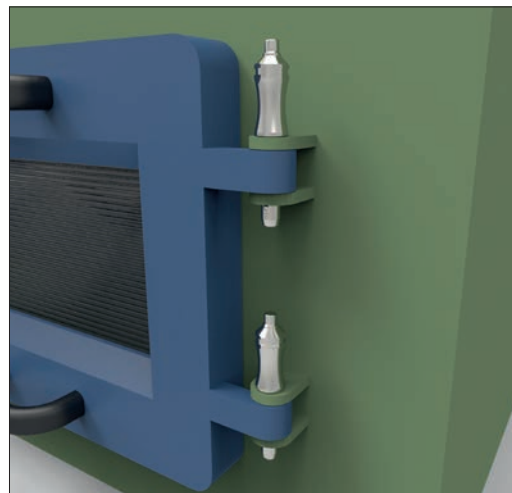

Scientific and Medical

ov-W33060.BK-A-TOR1706-W33250-A-TLA1066-a-rmh - Updated - 27-10-2022



Pin Material

1.4305 (AISI 303) - shear force approx. 60% of higher material version 1.4542

1.4542 (AISI 630) - identified by the ridge on the pin

CRES 17-4PH (AMS 5643) aviation standard



Handle Style



Plastic tri-star



T-handled, metal



L-handled, metal

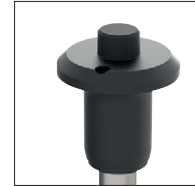

Mushroom, metal



Single piece metal, contoured



Special plastic self-spring



Adjustable grip length, plastic



Key ring



Safety, metal



Mushroom Type B aviation

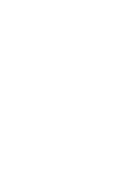

Type R aviation

Lanyards and Locating Bushes



Stainless wire - (coated) - 2 x key ring



Stainless wire - Key ring and fixing loop



Plastic - 2 x cable tie



Steel wire - (coated) - 2 x key ring



Stainless bead chain - 2 x key ring



Locating bushes

Actuation



Press = unlock
Release = lock (standard)



Press = unlock and position
Release = lock and simultaneous clamp



Simple spring loaded balls "pullout pin"

Important Note

Important Note: Ball lock pins are not suited to lifting applications!
For quick release lifting pins, see part 33400.

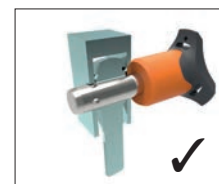

Shear force



Lifting force

Special Variations



Variations on our standard designs are possible, please contact our sales team for technical assistance. Quick production on specials can be as little as 3 weeks.



Applications

- Positioning.
- Lifting.
- Locking.
- Indexing.
- Joining.

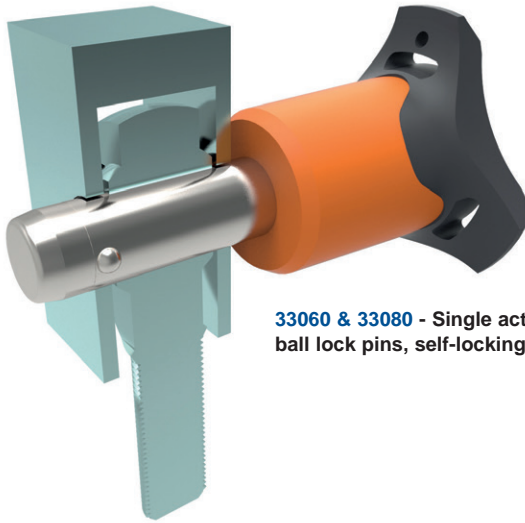

33060 & 33080 - Single acting ball lock pins, self-locking.



33194 - Single acting ball lock pins, self locking, simple finish.



33140 - Socket pins, non-locking, spring loaded balls.



33100 - Single acting ball lock pin, self locking.



33180 - Clamping pins, with span compensation, self-locking.

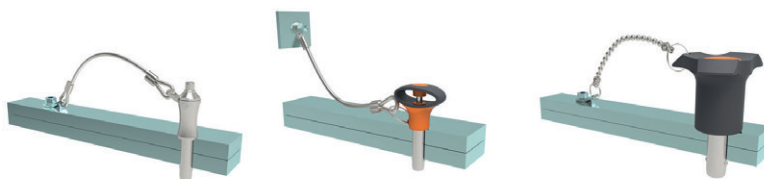

33250 & 33270 - Lanyards.



33220 - Ball lock pins, single acting - L-handle



33200.1

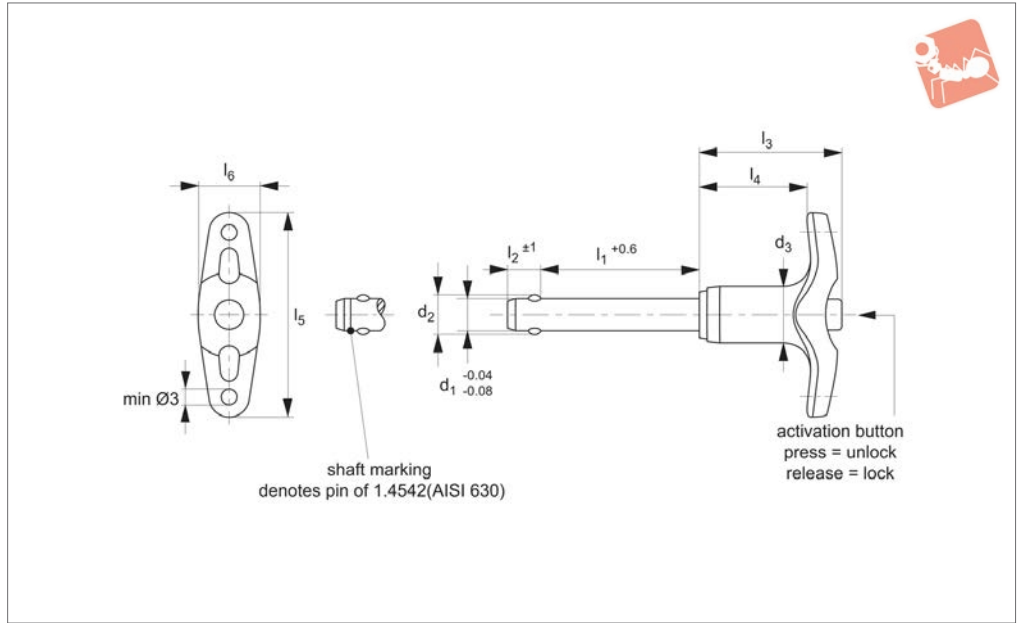

Material

Pin: stainless steel 1.4305 (AISI 303).
 Ball: stainless steel 1.3541
 Handle: aluminium, black (similar to RAL 9005)
 Spring: stainless Steel.

Technical Notes

Pressing = unlocking.

Releasing = locking.

Temperature range -30°C to +150°C.
 For quick fastening and locking frequently repeated connections.

Tips

For lanyards & retaining cables see part no.33250-33261. Easy install locating bushes available see part no.33248 +

33246.

Important Notes

*Shearing resistance similar to DIN 50141.

Order No.	Material	d ₁	l ₁	d ₂	d ₃	l ₂	l ₃	l ₄	l ₅	l ₆	Location hole dia. tol. H11	Shearing resistance, double kN min.	Weight g
33200.W0007	Stainless 1.4305	5	45	5,5	11,8	6,0	31,6	24,1	45,2	12,7	5	14	25
33200.W0008	Stainless 1.4305	5	50	5,5	11,8	6,0	31,6	24,1	45,2	12,7	5	14	26
33200.W0009	Stainless 1.4305	5	60	5,5	11,8	6,0	31,6	24,1	45,2	12,7	5	14	27
33200.W0010	Stainless 1.4305	5	70	5,5	11,8	6,0	31,6	24,1	45,2	12,7	5	14	29
33200.W0011	Stainless 1.4305	5	80	5,5	11,8	6,0	31,6	24,1	45,2	12,7	5	14	30
33200.W0012	Stainless 1.4305	5	10	5,5	11,8	6,0	31,6	24,1	45,2	12,7	5	14	19
33200.W0013	Stainless 1.4305	5	15	5,5	11,8	6,0	31,6	24,1	45,2	12,7	5	14	20
33200.W0014	Stainless 1.4305	5	20	5,5	11,8	6,0	31,6	24,1	45,2	12,7	5	14	20
33200.W0015	Stainless 1.4305	5	25	5,5	11,8	6,0	31,6	24,1	45,2	12,7	5	14	21
33200.W0016	Stainless 1.4305	5	30	5,5	11,8	6,0	31,6	24,1	45,2	12,7	5	14	22
33200.W0017	Stainless 1.4305	5	35	5,5	11,8	6,0	31,6	24,1	45,2	12,7	5	14	24
33200.W0018	Stainless 1.4305	5	40	5,5	11,8	6,0	31,6	24,1	45,2	12,7	5	14	24
33200.W0019	Stainless 1.4305	6	60	7,0	11,8	7,0	31,6	24,1	45,2	12,7	6	21	31
33200.W0020	Stainless 1.4305	6	70	7,0	11,8	7,0	31,6	24,1	45,2	12,7	6	21	33
33200.W0021	Stainless 1.4305	6	80	7,0	11,8	7,0	31,6	24,1	45,2	12,7	6	21	35
33200.W0022	Stainless 1.4305	6	10	7,0	11,8	7,0	31,6	24,1	45,2	12,7	6	21	20
33200.W0023	Stainless 1.4305	6	15	7,0	11,8	7,0	31,6	24,1	45,2	12,7	6	21	21
33200.W0024	Stainless 1.4305	6	20	7,0	11,8	7,0	31,6	24,1	45,2	12,7	6	21	22
33200.W0025	Stainless 1.4305	6	25	7,0	11,8	7,0	31,6	24,1	45,2	12,7	6	21	23
33200.W0026	Stainless 1.4305	6	30	7,0	11,8	7,0	31,6	24,1	45,2	12,7	6	21	24
33200.W0027	Stainless 1.4305	6	35	7,0	11,8	7,0	31,6	24,1	45,2	12,7	6	21	25
33200.W0028	Stainless 1.4305	6	40	7,0	11,8	7,0	31,6	24,1	45,2	12,7	6	21	26
33200.W0029	Stainless 1.4305	6	45	7,0	11,8	7,0	31,6	24,1	45,2	12,7	6	21	27
33200.W0030	Stainless 1.4305	6	50	7,0	11,8	7,0	31,6	24,1	45,2	12,7	6	21	28
33200.W0031	Stainless 1.4305	8	60	9,5	14,7	8,2	35,8	26,9	51,5	15,8	8	38	52
33200.W0032	Stainless 1.4305	8	10	9,5	14,7	8,2	35,8	26,9	51,5	15,8	8	38	33
33200.W0033	Stainless 1.4305	8	15	9,5	14,7	8,2	35,8	26,9	51,5	15,8	8	38	35

Ball Lock Pins & Quick Release



Ball Lock Pins - Single Acting - T-self-locking - stainless 1.4305



BALL LOCK PINS & QUICK RELEASE PINS

Order No.	Material	d ₁	l ₁	d ₂	d ₃	l ₂	l ₃	l ₄	l ₅	l ₆	Location hole dia. tol. H11	Shearing resistance, double kN min.	Weight g
33200.W0100	Stainless 1.4305	25	50	31,0	30,4	22,0	54,8	37,5	88,7	33,2	25	386	447
33200.W0101	Stainless 1.4305	25	60	31,0	30,4	22,0	54,8	37,5	88,7	33,2	25	386	484
33200.W0102	Stainless 1.4305	25	70	31,0	30,4	22,0	54,8	37,5	88,7	33,2	25	386	522
33200.W0103	Stainless 1.4305	25	80	31,0	30,4	22,0	54,8	37,5	88,7	33,2	25	386	560
33200.W0104	Stainless 1.4305	25	90	31,0	30,4	22,0	54,8	37,5	88,7	33,2	25	386	598
33200.W0105	Stainless 1.4305	25	100	31,0	30,4	22,0	54,8	37,5	88,7	33,2	25	386	636
33200.W0106	Stainless 1.4305	25	110	31,0	30,4	22,0	54,8	37,5	88,7	33,2	25	386	674
33200.W0107	Stainless 1.4305	25	120	31,0	30,4	22,0	54,8	37,5	88,7	33,2	25	386	712
33200.W0108	Stainless 1.4305	25	130	31,0	30,4	22,0	54,8	37,5	88,7	33,2	25	386	750
33200.W0109	Stainless 1.4305	25	140	31,0	30,4	22,0	54,8	37,5	88,7	33,2	25	386	788
33200.W0110	Stainless 1.4305	25	150	31,0	30,4	22,0	54,8	37,5	88,7	33,2	25	386	825



Ball Lock Pins - Single Acting - T- self-locking - stainless 1.4542

Ball Lock Pins & Quick Release

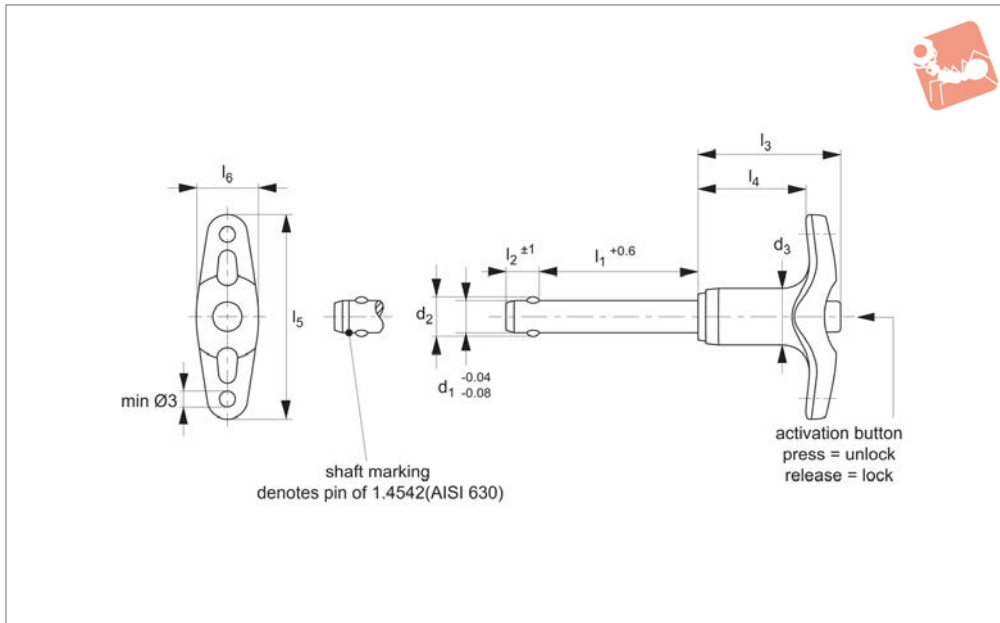

33200.2

BALL LOCK PINS & QUICK RELEASE PINS

Material

Pin: stainless steel 1.4542 (AISI 630).
Precipitation hardened, blast finish. Offering extreme load capacity. (Marked at end of shaft to denote 1.4542 material).
Ball: stainless steel 1.3541
Handle: aluminium, black (RAL9003).
Spring: stainless steel.

Technical Notes

Pressing = unlocking.
Releasing = locking.
Temperature range -30°C to +150°C.
For quick fastening and locking frequently repeated connections.

Tips

For lanyards & retaining cables see part no.33250-33261. Easy install locating bushes available see part no.33248 + 33246.

Important Notes

*Shearing resistance similar to DIN 50141.

Order No.	Material	d ₁	l ₁	d ₂	d ₃	l ₂	l ₃	l ₄	l ₅	l ₆	Location hole dia. tol. H11	Shearing resistance, double kN min.	Weight g
33200.W0307	Stainless 1.4542	5	45	5,5	11,8	6,0	31,6	24,1	45,2	12,7	5	24	25
33200.W0308	Stainless 1.4542	5	50	5,5	11,8	6,0	31,6	24,1	45,2	12,7	5	24	26
33200.W0309	Stainless 1.4542	5	60	5,5	11,8	6,0	31,6	24,1	45,2	12,7	5	24	27
33200.W0310	Stainless 1.4542	5	70	5,5	11,8	6,0	31,6	24,1	45,2	12,7	5	24	29
33200.W0311	Stainless 1.4542	5	80	5,5	11,8	6,0	31,6	24,1	45,2	12,7	5	24	30
33200.W0312	Stainless 1.4542	5	10	5,5	11,8	6,0	31,6	24,1	45,2	12,7	5	24	19
33200.W0313	Stainless 1.4542	5	15	5,5	11,8	6,0	31,6	24,1	45,2	12,7	5	24	20
33200.W0314	Stainless 1.4542	5	20	5,5	11,8	6,0	31,6	24,1	45,2	12,7	5	24	20
33200.W0315	Stainless 1.4542	5	25	5,5	11,8	6,0	31,6	24,1	45,2	12,7	5	24	21
33200.W0316	Stainless 1.4542	5	30	5,5	11,8	6,0	31,6	24,1	45,2	12,7	5	24	22
33200.W0317	Stainless 1.4542	5	35	5,5	11,8	6,0	31,6	24,1	45,2	12,7	5	24	24
33200.W0318	Stainless 1.4542	5	40	5,5	11,8	6,0	31,6	24,1	45,2	12,7	5	24	24
33200.W0319	Stainless 1.4542	6	60	7,0	11,8	7,0	31,6	24,1	45,2	12,7	6	35	31
33200.W0320	Stainless 1.4542	6	70	7,0	11,8	7,0	31,6	24,1	45,2	12,7	6	35	33
33200.W0321	Stainless 1.4542	6	80	7,0	11,8	7,0	31,6	24,1	45,2	12,7	6	35	35
33200.W0322	Stainless 1.4542	6	10	7,0	11,8	7,0	31,6	24,1	45,2	12,7	6	35	20
33200.W0323	Stainless 1.4542	6	15	7,0	11,8	7,0	31,6	24,1	45,2	12,7	6	35	21
33200.W0324	Stainless 1.4542	6	20	7,0	11,8	7,0	31,6	24,1	45,2	12,7	6	35	22
33200.W0325	Stainless 1.4542	6	25	7,0	11,8	7,0	31,6	24,1	45,2	12,7	6	35	23
33200.W0326	Stainless 1.4542	6	30	7,0	11,8	7,0	31,6	24,1	45,2	12,7	6	35	24
33200.W0327	Stainless 1.4542	6	35	7,0	11,8	7,0	31,6	24,1	45,2	12,7	6	35	25
33200.W0328	Stainless 1.4542	6	40	7,0	11,8	7,0	31,6	24,1	45,2	12,7	6	35	26
33200.W0329	Stainless 1.4542	6	45	7,0	11,8	7,0	31,6	24,1	45,2	12,7	6	35	27
33200.W0330	Stainless 1.4542	6	50	7,0	11,8	7,0	31,6	24,1	45,2	12,7	6	35	28
33200.W0331	Stainless 1.4542	8	60	9,5	14,7	8,2	35,8	26,9	51,5	15,8	8	63	52
33200.W0332	Stainless 1.4542	8	10	9,5	14,7	8,2	35,8	26,9	51,5	15,8	8	63	33
33200.W0333	Stainless 1.4542	8	15	9,5	14,7	8,2	35,8	26,9	51,5	15,8	8	63	35
33200.W0334	Stainless 1.4542	8	20	9,5	14,7	8,2	35,8	26,9	51,5	15,8	8	63	37



Ball Lock Pins - Single Acting - T- self-locking - stainless 1.4542

Ball Lock Pins & Quick Release



Order No.	Material	d ₁	l ₁	d ₂	d ₃	l ₂	l ₃	l ₄	l ₅	l ₆	Location hole dia. tol. H11	Shearing resistance, double kN min.	Weight g
33200.W3100	Stainless 1.4542	25	50	31,0	30,4	22,0	54,8	37,5	88,7	33,2	25	631	447
33200.W3101	Stainless 1.4542	25	60	31,0	30,4	22,0	54,8	37,5	88,7	33,2	25	631	484
33200.W3102	Stainless 1.4542	25	70	31,0	30,4	22,0	54,8	37,5	88,7	33,2	25	631	522
33200.W3103	Stainless 1.4542	25	80	31,0	30,4	22,0	54,8	37,5	88,7	33,2	25	631	560
33200.W3104	Stainless 1.4542	25	90	31,0	30,4	22,0	54,8	37,5	88,7	33,2	25	631	598
33200.W3105	Stainless 1.4542	25	100	31,0	30,4	22,0	54,8	37,5	88,7	33,2	25	631	636
33200.W3106	Stainless 1.4542	25	110	31,0	30,4	22,0	54,8	37,5	88,7	33,2	25	631	674
33200.W3107	Stainless 1.4542	25	120	31,0	30,4	22,0	54,8	37,5	88,7	33,2	25	631	712
33200.W3108	Stainless 1.4542	25	130	31,0	30,4	22,0	54,8	37,5	88,7	33,2	25	631	750
33200.W3110	Stainless 1.4542	25	150	31,0	30,4	22,0	54,8	37,5	88,7	33,2	25	631	825

BALL LOCK PINS & QUICK RELEASE PINS



33220.1

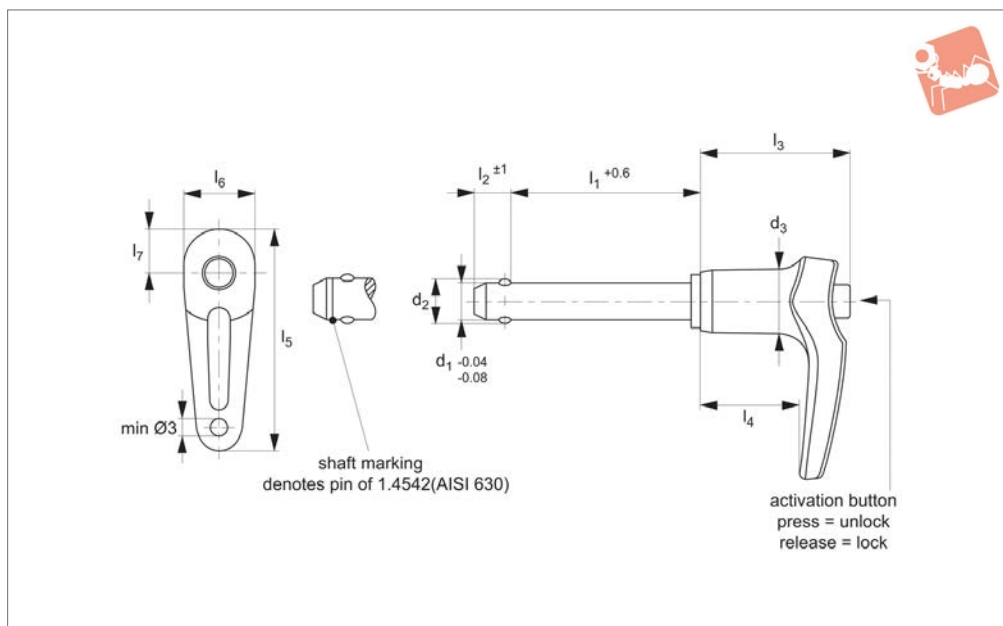

Material

Pin: stainless steel 1.4305 (AISI 303).
Ball: stainless steel 1.3541
Spring: stainless steel

Releasing = locking.

Temperature resistance -30°C to +150°C.
For quick fastening and locking of frequently repeated connections.

33250. Easy install locating bushes available see part no. 33248.

Important Notes

*Shearing resistance similar to DIN 50141.

Technical Notes

Pressing = unlocking.

Tips

For lanyards & retaining cables see aprt no.

Order No.	Material	d ₁	l ₁	d ₂	d ₃	l ₂	l ₃	l ₄	l ₅	l ₆	l ₇	Location hole dia.	Shearing resistance kN	Weight g
33220.W0112	Stainless 1.4305	5	10	5.5	11.8	6.0	31.6	21.9	43.8	12.6	8.5	5	14	20
33220.W0113	Stainless 1.4305	5	15	5.5	11.8	6.0	31.6	21.9	43.8	12.6	8.5	5	14	21
33220.W0114	Stainless 1.4305	5	20	5.5	11.8	6.0	31.6	21.9	43.8	12.6	8.5	5	14	21
33220.W0115	Stainless 1.4305	5	25	5.5	11.8	6.0	31.6	21.9	43.8	12.6	8.5	5	14	22
33220.W0116	Stainless 1.4305	5	30	5.5	11.8	6.0	31.6	21.9	43.8	12.6	8.5	5	14	23
33220.W0122	Stainless 1.4305	6	10	7.0	11.8	7.0	31.6	21.9	43.8	12.6	8.5	6	21	21
33220.W0123	Stainless 1.4305	6	15	7.0	11.8	7.0	31.6	21.9	43.8	12.6	8.5	6	21	22
33220.W0124	Stainless 1.4305	6	20	7.0	11.8	7.0	31.6	21.9	43.8	12.6	8.5	6	21	23
33220.W0125	Stainless 1.4305	6	25	7.0	11.8	7.0	31.6	21.9	43.8	12.6	8.5	6	21	24
33220.W0126	Stainless 1.4305	6	30	7.0	11.8	7.0	31.6	21.9	43.8	12.6	8.5	6	21	25
33220.W0127	Stainless 1.4305	6	35	7.0	11.8	7.0	31.6	21.9	43.8	12.6	8.5	6	21	26
33220.W0128	Stainless 1.4305	6	40	7.0	11.8	7.0	31.6	21.9	43.8	12.6	8.5	6	21	27
33220.W0129	Stainless 1.4305	6	45	7.0	11.8	7.0	31.6	21.9	43.8	12.6	8.5	6	21	28
33220.W0130	Stainless 1.4305	6	50	7.0	11.8	7.0	31.6	21.9	43.8	12.6	8.5	6	21	29
33220.W0134	Stainless 1.4305	8	20	9.5	14.7	8.2	35.8	24.4	49.7	15.8	9.9	8	38	37

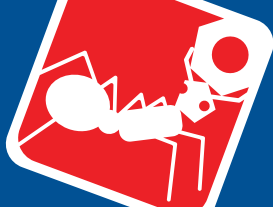

Ball Lock Pins - Single Acting - L- self-locking - stainless 1.4305

Ball Lock Pins & Quick Release



Order No.	Material	d ₁	l ₁	d ₂	d ₃	l ₂	l ₃	l ₄	l ₅	l ₆	l ₇	Location hole dia.	Shearing resistance kN	Weight g
33220.W0135	Stainless 1.4305	8	25	9.5	14.7	8.2	35.8	24.4	49.7	15.8	9.9	8	38	39
33220.W0136	Stainless 1.4305	8	30	9.5	14.7	8.2	35.8	24.4	49.7	15.8	9.9	8	38	41
33220.W0137	Stainless 1.4305	8	35	9.5	14.7	8.2	35.8	24.4	49.7	15.8	9.9	8	38	43
33220.W0138	Stainless 1.4305	8	40	9.5	14.7	8.2	35.8	24.4	49.7	15.8	9.9	8	38	45
33220.W0139	Stainless 1.4305	8	45	9.5	14.7	8.2	35.8	24.4	49.7	15.8	9.9	8	38	46
33220.W0140	Stainless 1.4305	8	50	9.5	14.7	8.2	35.8	24.4	49.7	15.8	9.9	8	38	48
33220.W0144	Stainless 1.4305	10	20	12.0	14.7	9.6	35.8	24.4	49.7	15.8	9.9	10	60	44
33220.W0145	Stainless 1.4305	10	25	12.0	14.7	9.6	35.8	24.4	49.7	15.8	9.9	10	60	47
33220.W0146	Stainless 1.4305	10	30	12.0	14.7	9.6	35.8	24.4	49.7	15.8	9.9	10	60	50
33220.W0147	Stainless 1.4305	10	35	12.0	14.7	9.6	35.8	24.4	49.7	15.8	9.9	10	60	53
33220.W0148	Stainless 1.4305	10	40	12.0	14.7	9.6	35.8	24.4	49.7	15.8	9.9	10	60	56
33220.W0149	Stainless 1.4305	10	45	12.0	14.7	9.6	35.8	24.4	49.7	15.8	9.9	10	60	58
33220.W0150	Stainless 1.4305	10	50	12.0	14.7	9.6	35.8	24.4	49.7	15.8	9.9	10	60	62
33220.W0152	Stainless 1.4305	10	60	12.0	14.7	9.6	35.8	24.4	49.7	15.8	9.9	10	60	67
33220.W0165	Stainless 1.4305	12	25	14.5	18.2	10.6	35.1	22.7	57.1	20.2	12.6	12	87	73
33220.W0166	Stainless 1.4305	12	30	14.5	18.2	10.6	35.1	22.7	57.1	20.2	12.6	12	87	77
33220.W0167	Stainless 1.4305	12	35	14.5	18.2	10.6	35.1	22.7	57.1	20.2	12.6	12	87	82
33220.W0168	Stainless 1.4305	12	40	14.5	18.2	10.6	35.1	22.7	57.1	20.2	12.6	12	87	86
33220.W0169	Stainless 1.4305	12	45	14.5	18.2	10.6	35.1	22.7	57.1	20.2	12.6	12	87	90
33220.W0170	Stainless 1.4305	12	50	14.5	18.2	10.6	35.1	22.7	57.1	20.2	12.6	12	87	94
33220.W0172	Stainless 1.4305	12	60	14.5	18.2	10.6	35.1	22.7	57.1	20.2	12.6	12	87	103
33220.W0174	Stainless 1.4305	12	70	14.5	18.2	10.6	35.1	22.7	57.1	20.2	12.6	12	87	111
33220.W0176	Stainless 1.4305	12	80	14.5	18.2	10.6	35.1	22.7	57.1	20.2	12.6	12	87	120

BALL LOCK PINS & QUICK RELEASE PINS



33220.2

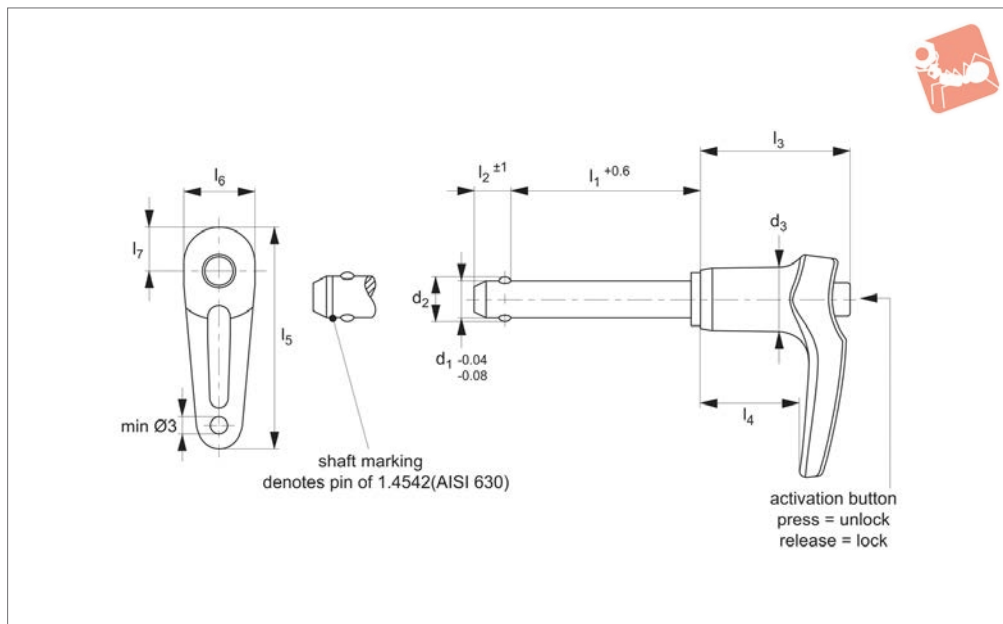

Material

Pin: stainless steel 1.4542 (AISI 630).
 Precipitation hardened, blast finish. Offering extreme load capacity. (Marked at end of shaft to denote 1.4542 material).
 Ball: stainless steel 1.3541
 Handle: aluminium, black (RAL9003).
 Spring: stainless steel.

Technical Notes

Pressing = unlocking.
 Releasing = locking.
 Temperature resistance -30°C to +150°C.
 For quick fastening and locking of frequently repeated connections.

Tips

For lanyards & retaining cables see aprt no. 33250. Easy install locating bushes available see part no. 33248.

Important Notes

*Shearing resistance similar to DIN 50141.

Order No.	Material	d ₁	l ₁	d ₂	d ₃	Weight g
33220.W0312	Stainless 1.4542	5	10	5.5	11.8	20
33220.W0313	Stainless 1.4542	5	15	5.5	11.8	21
33220.W0314	Stainless 1.4542	5	20	5.5	11.8	21
33220.W0315	Stainless 1.4542	5	25	5.5	11.8	22
33220.W0316	Stainless 1.4542	5	30	5.5	11.8	23
33220.W0322	Stainless 1.4542	6	10	7.0	11.8	21
33220.W0323	Stainless 1.4542	6	15	7.0	11.8	22
33220.W0324	Stainless 1.4542	6	20	7.0	11.8	23
33220.W0325	Stainless 1.4542	6	25	7.0	11.8	24
33220.W0326	Stainless 1.4542	6	30	7.0	11.8	25
33220.W0327	Stainless 1.4542	6	35	7.0	11.8	26
33220.W0328	Stainless 1.4542	6	40	7.0	11.8	27
33220.W0329	Stainless 1.4542	6	45	7.0	11.8	28
33220.W0330	Stainless 1.4542	6	50	7.0	11.8	29
33220.W0334	Stainless 1.4542	8	20	9.5	14.7	37
33220.W0335	Stainless 1.4542	8	25	9.5	14.7	39
33220.W0336	Stainless 1.4542	8	30	9.5	14.7	41
33220.W0337	Stainless 1.4542	8	35	9.5	14.7	43
33220.W0338	Stainless 1.4542	8	40	9.5	14.7	45
33220.W0339	Stainless 1.4542	8	45	9.5	14.7	46
33220.W0340	Stainless 1.4542	8	50	9.5	14.7	48
33220.W0344	Stainless 1.4542	10	20	12.0	14.7	44
33220.W0345	Stainless 1.4542	10	25	12.0	14.7	47
33220.W0346	Stainless 1.4542	10	30	12.0	14.7	50
33220.W0347	Stainless 1.4542	10	35	12.0	14.7	53
33220.W0348	Stainless 1.4542	10	40	12.0	14.7	56
33220.W0349	Stainless 1.4542	10	45	12.0	14.7	58
33220.W0350	Stainless 1.4542	10	50	12.0	14.7	62
33220.W0352	Stainless 1.4542	10	60	12.0	14.7	67



Ball Lock Pins - Single Acting - L- self-locking - stainless 1.4542

Ball Lock Pins & Quick Release



Order No.	Material	d ₁	l ₁	d ₂	d ₃	Weight g
33220.W0365	Stainless 1.4542	12	25	14.5	18.2	73
33220.W0366	Stainless 1.4542	12	30	14.5	18.2	77
33220.W0367	Stainless 1.4542	12	35	14.5	18.2	82
33220.W0368	Stainless 1.4542	12	40	14.5	18.2	86
33220.W0369	Stainless 1.4542	12	45	14.5	18.2	90
33220.W0370	Stainless 1.4542	12	50	14.5	18.2	94
33220.W0372	Stainless 1.4542	12	60	14.5	18.2	103
33220.W0374	Stainless 1.4542	12	70	14.5	18.2	111
33220.W0376	Stainless 1.4542	12	80	14.5	18.2	120

Order No.	l ₂	l ₃	l ₄	l ₅	l ₆	l ₇	Location hole dia. tol. H11	Shearing resistance kN
33220.W0312	6.0	31.6	21.9	43.8	12.6	8.5	5	24
33220.W0313	6.0	31.6	21.9	43.8	12.6	8.5	5	24
33220.W0314	6.0	31.6	21.9	43.8	12.6	8.5	5	24
33220.W0315	6.0	31.6	21.9	43.8	12.6	8.5	5	24
33220.W0316	6.0	31.6	21.9	43.8	12.6	8.5	5	24
33220.W0322	7.0	31.6	21.9	43.8	12.6	8.5	6	35
33220.W0323	7.0	31.6	21.9	43.8	12.6	8.5	6	35
33220.W0324	7.0	31.6	21.9	43.8	12.6	8.5	6	35
33220.W0325	7.0	31.6	21.9	43.8	12.6	8.5	6	35
33220.W0326	7.0	31.6	21.9	43.8	12.6	8.5	6	35
33220.W0327	7.0	31.6	21.9	43.8	12.6	8.5	6	35
33220.W0328	7.0	31.6	21.9	43.8	12.6	8.5	6	35
33220.W0329	7.0	31.6	21.9	43.8	12.6	8.5	6	35
33220.W0330	7.0	31.6	21.9	43.8	12.6	8.5	6	35
33220.W0334	8.2	35.8	24.4	49.7	15.8	9.9	8	63
33220.W0335	8.2	35.8	24.4	49.7	15.8	9.9	8	63
33220.W0336	8.2	35.8	24.4	49.7	15.8	9.9	8	63
33220.W0337	8.2	35.8	24.4	49.7	15.8	9.9	8	63
33220.W0338	8.2	35.8	24.4	49.7	15.8	9.9	8	63
33220.W0339	8.2	35.8	24.4	49.7	15.8	9.9	8	63
33220.W0340	8.2	35.8	24.4	49.7	15.8	9.9	8	63
33220.W0344	9.6	35.8	24.4	49.7	15.8	9.9	10	100
33220.W0345	9.6	35.8	24.4	49.7	15.8	9.9	10	100
33220.W0346	9.6	35.8	24.4	49.7	15.8	9.9	10	100
33220.W0347	9.6	35.8	24.4	49.7	15.8	9.9	10	100
33220.W0348	9.6	35.8	24.4	49.7	15.8	9.9	10	100
33220.W0349	9.6	35.8	24.4	49.7	15.8	9.9	10	100
33220.W0350	9.6	35.8	24.4	49.7	15.8	9.9	10	100
33220.W0352	9.6	35.8	24.4	49.7	15.8	9.9	10	100
33220.W0365	10.6	35.1	22.7	57.1	20.2	12.6	12	144
33220.W0366	10.6	35.1	22.7	57.1	20.2	12.6	12	144
33220.W0367	10.6	35.1	22.7	57.1	20.2	12.6	12	144
33220.W0368	10.6	35.1	22.7	57.1	20.2	12.6	12	144
33220.W0369	10.6	35.1	22.7	57.1	20.2	12.6	12	144
33220.W0370	10.6	35.1	22.7	57.1	20.2	12.6	12	144
33220.W0372	10.6	35.1	22.7	57.1	20.2	12.6	12	144
33220.W0374	10.6	35.1	22.7	57.1	20.2	12.6	12	144
33220.W0376	10.6	35.1	22.7	57.1	20.2	12.6	12	144

BALL LOCK PINS & QUICK RELEASE PINS



BALL LOCK PINS & QUICK RELEASE PINS



33224.1

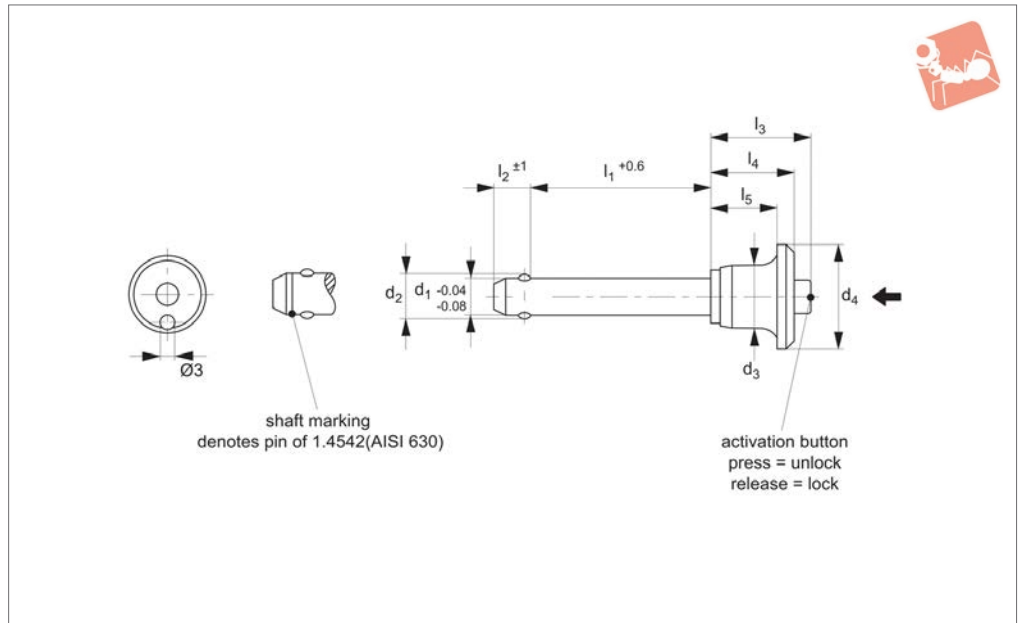

Material

Pin: Stainless steel 1.4305 (AISI 303).
Ball: stainless steel 1.3541
Spring: stainless steel.
Handle: aluminium, black (RAL9003).

Releasing = locking.

Temperature resistance -30°C to +150°C
For quick fastening and locking of frequently repeated connections.

available see part no. 33248.

Important Notes

*Shearing resistance similar to DIN 50141.

Technical Notes

Pressing = unlocking.

Tips

For lanyards & retaining cables see part no. 33250. Easy install locating bushes

Order No.	Stainless type	d ₁	d ₂	d ₃	d ₄	l ₁	l ₂	l ₃	l ₄	l ₅	Location hole	Shearing resistance, double kN	Weight g
33224.W0085	Stainless 1.4305	16	19.0	23.4	40	120	14.0	42.2	34.5	28.5	16	155	283
33224.W0212	Stainless 1.4305	5	5.5	11.3	20	10	6.0	20.7	17.6	14.6	5	14	12
33224.W0213	Stainless 1.4305	5	5.5	11.3	20	15	6.0	20.7	17.6	14.6	5	14	12
33224.W0214	Stainless 1.4305	5	5.5	11.3	20	20	6.0	20.7	17.6	14.6	5	14	13
33224.W0215	Stainless 1.4305	5	5.5	11.3	20	25	6.0	20.7	17.6	14.6	5	14	14
33224.W0216	Stainless 1.4305	5	5.5	11.3	20	30	6.0	20.7	17.6	14.6	5	14	15
33224.W0221	Stainless 1.4305	6	7.0	11.3	20	80	7.0	20.7	17.6	14.6	6	21	27
33224.W0222	Stainless 1.4305	6	7.0	11.3	20	10	7.0	20.7	17.6	14.6	6	21	13
33224.W0223	Stainless 1.4305	6	7.0	11.3	20	15	7.0	20.7	17.6	14.6	6	21	14
33224.W0224	Stainless 1.4305	6	7.0	11.3	20	20	7.0	20.7	17.6	14.6	6	21	15
33224.W0225	Stainless 1.4305	6	7.0	11.3	20	25	7.0	20.7	17.6	14.6	6	21	16
33224.W0226	Stainless 1.4305	6	7.0	11.3	20	30	7.0	20.7	17.6	14.6	6	21	17
33224.W0227	Stainless 1.4305	6	7.0	11.3	20	35	7.0	20.7	17.6	14.6	6	21	18
33224.W0228	Stainless 1.4305	6	7.0	11.3	20	40	7.0	20.7	17.6	14.6	6	21	19
33224.W0229	Stainless 1.4305	6	7.0	11.3	20	45	7.0	20.7	17.6	14.6	6	21	20
33224.W0230	Stainless 1.4305	6	7.0	11.3	20	50	7.0	20.7	17.6	14.6	6	21	21
33224.W0234	Stainless 1.4305	8	9.5	14.1	25	20	8.2	27.3	22.6	18.6	8	38	28
33224.W0235	Stainless 1.4305	8	9.5	14.1	25	25	8.2	27.3	22.6	18.6	8	38	30
33224.W0236	Stainless 1.4305	8	9.5	14.1	25	30	8.2	27.3	22.6	18.6	8	38	32
33224.W0237	Stainless 1.4305	8	9.5	14.1	25	35	8.2	27.3	22.6	18.6	8	38	34
33224.W0238	Stainless 1.4305	8	9.5	14.1	25	40	8.2	27.3	22.6	18.6	8	38	36
33224.W0239	Stainless 1.4305	8	9.5	14.1	25	45	8.2	27.3	22.6	18.6	8	38	38
33224.W0240	Stainless 1.4305	8	9.5	14.1	25	50	8.2	27.3	22.6	18.6	8	38	40
33224.W0244	Stainless 1.4305	10	12.0	14.1	25	20	9.6	27.3	22.6	18.6	10	60	35
33224.W0245	Stainless 1.4305	10	12.0	14.1	25	25	9.6	27.3	22.6	18.6	10	60	38
33224.W0246	Stainless 1.4305	10	12.0	14.1	25	30	9.6	27.3	22.6	18.6	10	60	40
33224.W0247	Stainless 1.4305	10	12.0	14.1	25	35	9.6	27.3	22.6	18.6	10	60	44
33224.W0248	Stainless 1.4305	10	12.0	14.1	25	40	9.6	27.3	22.6	18.6	10	60	47
33224.W0249	Stainless 1.4305	10	12.0	14.1	25	45	9.6	27.3	22.6	18.6	10	60	50
33224.W0250	Stainless 1.4305	10	12.0	14.1	25	50	9.6	27.3	22.6	18.6	10	60	53



Ball Lock Pins - Mushroom Handle

single acting - self-locking - stainless 1.4305

Ball Lock Pins & Quick Release



Order No.	Stainless type	d ₁	d ₂	d ₃	d ₄	l ₁	l ₂	l ₃	l ₄	l ₅	Location hole	Shearing resistance, double kN	Weight g
33224.W0252	Stainless 1.4305	10	12.0	14.1	25	60	9.6	27.3	22.6	18.6	10	60	59
33224.W0265	Stainless 1.4305	12	14.5	17.7	35	25	10.6	33.2	27.3	22.3	12	87	69
33224.W0266	Stainless 1.4305	12	14.5	17.7	35	30	10.6	33.2	27.3	22.3	12	87	73
33224.W0267	Stainless 1.4305	12	14.5	17.7	35	35	10.6	33.2	27.3	22.3	12	87	78
33224.W0268	Stainless 1.4305	12	14.5	17.7	35	40	10.6	33.2	27.3	22.3	12	87	82
33224.W0269	Stainless 1.4305	12	14.5	17.7	35	45	10.6	33.2	27.3	22.3	12	87	86
33224.W0270	Stainless 1.4305	12	14.5	17.7	35	50	10.6	33.2	27.3	22.3	12	87	90
33224.W0272	Stainless 1.4305	12	14.5	17.7	35	60	10.6	33.2	27.3	22.3	12	87	99
33224.W0274	Stainless 1.4305	12	14.5	17.7	35	70	10.6	33.2	27.3	22.3	12	87	108
33224.W0276	Stainless 1.4305	12	14.5	17.7	35	80	10.6	33.2	27.3	22.3	12	87	116
33224.W0303	Stainless 1.4305	25	31.0	30.4	50	80	22.0	54.8	43.5	36.5	25	386	547
33224.W0304	Stainless 1.4305	25	31.0	30.4	50	90	22.0	54.8	43.5	36.5	25	386	585
33224.W0306	Stainless 1.4305	25	31.0	30.4	50	110	22.0	54.8	43.5	36.5	25	386	660



BALL LOCK PINS & QUICK RELEASE PINS



33224.2

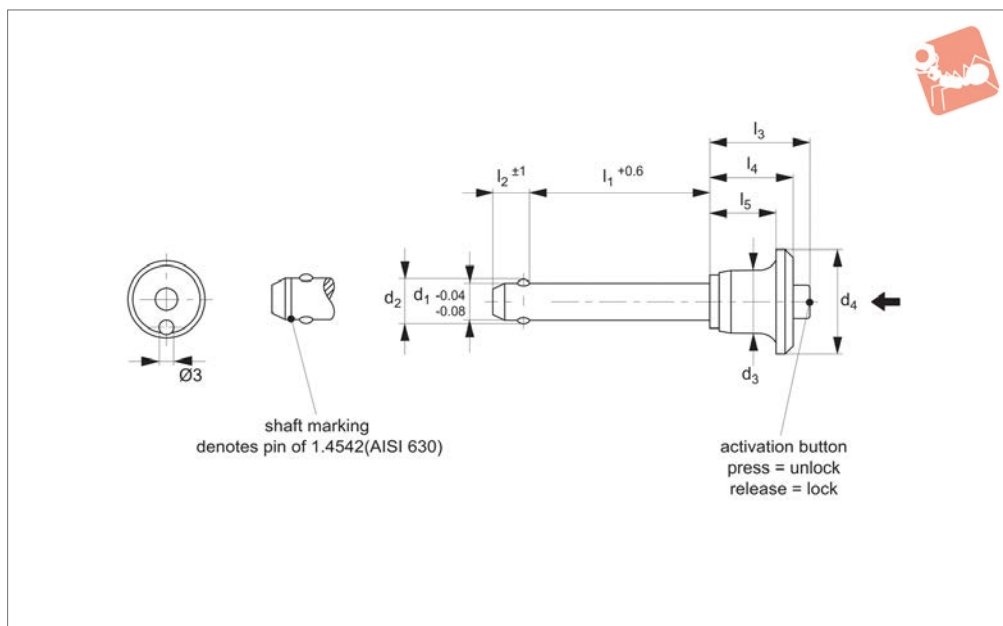

Material

Pin: Stainless steel 1.4542 (AISI 630), precipitation hardened, blast finish. Offering extreme load capacity. (Marked at end of shaft to denote 1.4542 material).
 Ball: stainless steel 1.3541
 Spring: stainless steel.
 Handle: aluminium, black (RAL9003).

Technical Notes

Pressing = unlocking.
 Releasing = locking.
 Temperature resistance -30°C to $+150^{\circ}\text{C}$
 For quick fastening and locking of frequently repeated connections.

Tips

For lanyards & retaining cables see part no. 33250. Easy install locating bushes available see part no. 33248.

Important Notes

*Shearing resistance similar to DIN 50141.

Order No.	Stainless type	d_1	d_2	d_3	d_4	l_1	l_2	l_3	l_4	l_5	Location hole	Shearing resistance, double kN	Weight g
33224.W0512	Stainless 1.4542	5	5.5	11.3	20	10	6.0	20.7	17.6	14.6	5	24	12
33224.W0513	Stainless 1.4542	5	5.5	11.3	20	15	6.0	20.7	17.6	14.6	5	24	12
33224.W0514	Stainless 1.4542	5	5.5	11.3	20	20	6.0	20.7	17.6	14.6	5	24	13
33224.W0515	Stainless 1.4542	5	5.5	11.3	20	25	6.0	20.7	17.6	14.6	5	24	14
33224.W0516	Stainless 1.4542	5	5.5	11.3	20	30	6.0	20.7	17.6	14.6	5	24	15
33224.W0522	Stainless 1.4542	6	7.0	11.3	20	10	7.0	20.7	17.6	14.6	6	35	13
33224.W0523	Stainless 1.4542	6	7.0	11.3	20	15	7.0	20.7	17.6	14.6	6	35	14
33224.W0524	Stainless 1.4542	6	7.0	11.3	20	20	7.0	20.7	17.6	14.6	6	35	15
33224.W0525	Stainless 1.4542	6	7.0	11.3	20	25	7.0	20.7	17.6	14.6	6	35	16
33224.W0526	Stainless 1.4542	6	7.0	11.3	20	30	7.0	20.7	17.6	14.6	6	35	17
33224.W0527	Stainless 1.4542	6	7.0	11.3	20	35	7.0	20.7	17.6	14.6	6	35	18
33224.W0528	Stainless 1.4542	6	7.0	11.3	20	40	7.0	20.7	17.6	14.6	6	35	19
33224.W0529	Stainless 1.4542	6	7.0	11.3	20	45	7.0	20.7	17.6	14.6	6	35	20
33224.W0530	Stainless 1.4542	6	7.0	11.3	20	50	7.0	20.7	17.6	14.6	6	35	21
33224.W0531	Stainless 1.4542	8	9.5	14.1	25	60	8.2	27.3	22.6	18.6	8	63	44
33224.W0534	Stainless 1.4542	8	9.5	14.1	25	20	8.2	27.3	22.6	18.6	8	63	28
33224.W0535	Stainless 1.4542	8	9.5	14.1	25	25	8.2	27.3	22.6	18.6	8	63	30
33224.W0536	Stainless 1.4542	8	9.5	14.1	25	30	8.2	27.3	22.6	18.6	8	63	32
33224.W0537	Stainless 1.4542	8	9.5	14.1	25	35	8.2	27.3	22.6	18.6	8	63	34
33224.W0538	Stainless 1.4542	8	9.5	14.1	25	40	8.2	27.3	22.6	18.6	8	63	36
33224.W0539	Stainless 1.4542	8	9.5	14.1	25	45	8.2	27.3	22.6	18.6	8	63	38
33224.W0540	Stainless 1.4542	8	9.5	14.1	25	50	8.2	27.3	22.6	18.6	8	63	40
33224.W0544	Stainless 1.4542	10	12.0	14.1	25	20	9.6	27.3	22.6	18.6	10	100	35
33224.W0545	Stainless 1.4542	10	12.0	14.1	25	25	9.6	27.3	22.6	18.6	10	100	38
33224.W0546	Stainless 1.4542	10	12.0	14.1	25	30	9.6	27.3	22.6	18.6	10	100	40
33224.W0547	Stainless 1.4542	10	12.0	14.1	25	35	9.6	27.3	22.6	18.6	10	100	44
33224.W0548	Stainless 1.4542	10	12.0	14.1	25	40	9.6	27.3	22.6	18.6	10	100	47
33224.W0549	Stainless 1.4542	10	12.0	14.1	25	45	9.6	27.3	22.6	18.6	10	100	50
33224.W0550	Stainless 1.4542	10	12.0	14.1	25	50	9.6	27.3	22.6	18.6	10	100	53



Ball Lock Pins - Mushroom Handle

single acting - self-locking - stainless 1.4542

Ball Lock Pins & Quick Release



Order No.	Stainless type	d ₁	d ₂	d ₃	d ₄	l ₁	l ₂	l ₃	l ₄	l ₅	Location hole	Shearing resistance, double kN	Weight g
33224.W0552	Stainless 1.4542	10	12.0	14.1	25	60	9.6	27.3	22.6	18.6	10	100	59
33224.W0565	Stainless 1.4542	12	14.5	17.7	35	25	10.6	33.2	27.3	22.3	12	144	69
33224.W0566	Stainless 1.4542	12	14.5	17.7	35	30	10.6	33.2	27.3	22.3	12	144	73
33224.W0567	Stainless 1.4542	12	14.5	17.7	35	35	10.6	33.2	27.3	22.3	12	144	78
33224.W0568	Stainless 1.4542	12	14.5	17.7	35	40	10.6	33.2	27.3	22.3	12	144	82
33224.W0569	Stainless 1.4542	12	14.5	17.7	35	45	10.6	33.2	27.3	22.3	12	144	86
33224.W0570	Stainless 1.4542	12	14.5	17.7	35	50	10.6	33.2	27.3	22.3	12	144	90
33224.W0572	Stainless 1.4542	12	14.5	17.7	35	60	10.6	33.2	27.3	22.3	12	144	99
33224.W0574	Stainless 1.4542	12	14.5	17.7	35	70	10.6	33.2	27.3	22.3	12	144	108
33224.W0576	Stainless 1.4542	12	14.5	17.7	35	80	10.6	33.2	27.3	22.3	12	144	116
33224.W0590	Stainless 1.4542	20	24.8	23.4	40	60	17.0	43.1	34.5	28.5	20	403	261



BALL LOCK PINS & QUICK RELEASE PINS



BALL LOCK PINS & QUICK RELEASE PINS



33230

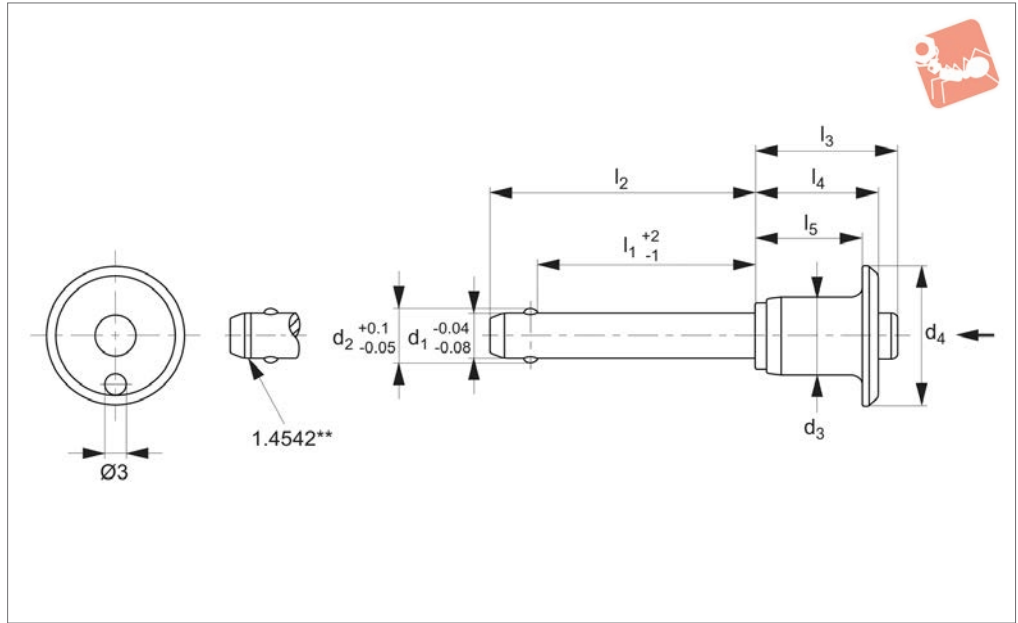

Material

Type One

Pin: Stainless steel 1.4305 (AISI 303).

Type Two

Pin: Stainless steel 1.4542 (AISI 630), precipitation hardened.

Both

Handle: Aluminium, black.

Button: Stainless steel, yellow.

Spring: Stainless steel.

Technical Notes

Not suitable for lifting loads.

Corrosion resistant.

Press button = unlocking.

Release button = clamping.

For securing in blind holes H_{11} . Tempera-

ture range -30 to 150°C.

Quick fastening, adjusting and locking of frequently repeated connections.

Tips

Used with:

33250: Lanyards & retaining cables

Important Notes

*Shearing resistance similar to DIN 50141.

Order No.	d ₁	Type	d ₂	d ₃	d ₄	Weight g
33230.W0022	6	Type One Stainless 1.4305	6.2	11.3	20	13
33230.W0122	6	Type Two Stainless 1.4542	6.2	11.3	20	13
33230.W0024	6	Type One Stainless 1.4305	6.2	11.3	20	15
33230.W0124	6	Type Two Stainless 1.4542	6.2	11.3	20	15
33230.W0028	6	Type One Stainless 1.4305	6.2	11.3	20	19
33230.W0128	6	Type Two Stainless 1.4542	6.2	11.3	20	19
33230.W0032	6	Type One Stainless 1.4305	6.2	11.3	20	23
33230.W0132	6	Type Two Stainless 1.4542	6.2	11.3	20	23
33230.W0042	8	Type One Stainless 1.4305	8.3	14.1	25	25
33230.W0142	8	Type Two Stainless 1.4542	8.3	14.1	25	25
33230.W0044	8	Type One Stainless 1.4305	8.3	14.1	25	28
33230.W0144	8	Type Two Stainless 1.4542	8.3	14.1	25	28
33230.W0048	8	Type One Stainless 1.4305	8.3	14.1	25	36
33230.W0148	8	Type Two Stainless 1.4542	8.3	14.1	25	36
33230.W0052	8	Type One Stainless 1.4305	8.3	14.1	25	43
33230.W0152	8	Type Two Stainless 1.4542	8.3	14.1	25	43
33230.W0056	8	Type One Stainless 1.4305	8.3	14.1	25	51
33230.W0156	8	Type Two Stainless 1.4542	8.3	14.1	25	51
33230.W0062	10	Type One Stainless 1.4305	10.3	14.1	25	35
33230.W0162	10	Type Two Stainless 1.4542	10.3	14.1	25	35
33230.W0066	10	Type One Stainless 1.4305	10.3	14.1	25	47
33230.W0166	10	Type Two Stainless 1.4542	10.3	14.1	25	47
33230.W0070	10	Type One Stainless 1.4305	10.3	14.1	25	58
33230.W0170	10	Type Two Stainless 1.4542	10.3	14.1	25	58
33230.W0072	10	Type One Stainless 1.4305	10.3	14.1	25	70
33230.W0172	10	Type Two Stainless 1.4542	10.3	14.1	25	70
33230.W0074	10	Type One Stainless 1.4305	10.3	14.1	25	83
33230.W0174	10	Type Two Stainless 1.4542	10.3	14.1	25	83



Clamp Lock Pins - Single Acting button handle - stainless steel

Ball Lock Pins & Quick Release



Order No.	l ₁	l ₂	l ₃	l ₄	Location hole dia. tol. H11	Shearing resistance, double (1.4305)		Shearing resistance, double (1.4542)	
						kN min.		kN min.	
33230.W0022	10	17.4	17.6	20.7	6	21	35	21	35
33230.W0122	10	17.4	17.6	20.7	6	21	35	21	35
33230.W0024	20	27.4	17.6	20.7	6	21	35	21	35
33230.W0124	20	27.4	17.6	20.7	6	21	35	21	35
33230.W0028	40	47.4	17.6	20.7	6	21	35	21	35
33230.W0128	40	47.4	17.6	20.7	6	21	35	21	35
33230.W0032	60	67.4	17.6	20.7	6	21	35	21	35
33230.W0132	60	67.4	17.6	20.7	6	21	35	21	35
33230.W0042	10	18.6	22.6	27.3	8	38	63	38	63
33230.W0142	10	18.6	22.6	27.3	8	38	63	38	63
33230.W0044	20	28.6	22.6	27.3	8	38	63	38	63
33230.W0144	20	28.6	22.6	27.3	8	38	63	38	63
33230.W0048	40	48.6	22.6	27.3	8	38	63	38	63
33230.W0148	40	48.6	22.6	27.3	8	38	63	38	63
33230.W0052	60	68.6	22.6	27.3	8	38	63	38	63
33230.W0152	60	68.6	22.6	27.3	8	38	63	38	63
33230.W0056	80	88.6	22.6	27.3	8	38	63	38	63
33230.W0156	80	88.6	22.6	27.3	8	38	63	38	63
33230.W0062	20	30.0	22.6	27.3	10	60	100	60	100
33230.W0162	20	30.0	22.6	27.3	10	60	100	60	100
33230.W0066	40	50.0	22.6	27.3	10	60	100	60	100
33230.W0166	40	50.0	22.6	27.3	10	60	100	60	100
33230.W0070	60	70.0	22.6	27.3	10	60	100	60	100
33230.W0170	60	70.0	22.6	27.3	10	60	100	60	100
33230.W0072	80	100.0	22.6	27.3	10	60	100	60	100
33230.W0172	80	100.0	22.6	27.3	10	60	100	60	100
33230.W0074	100	120.0	22.6	27.3	10	60	100	60	100
33230.W0174	100	120.0	22.6	27.3	10	60	100	60	100

BALL LOCK PINS & QUICK RELEASE PINS

Ball Lock Pins & Quick Release

Ball Lock Pins - Contoured Handle

self-locking - single acting - stainless 1.4305



BALL LOCK PINS & QUICK RELEASE PINS



33194.1

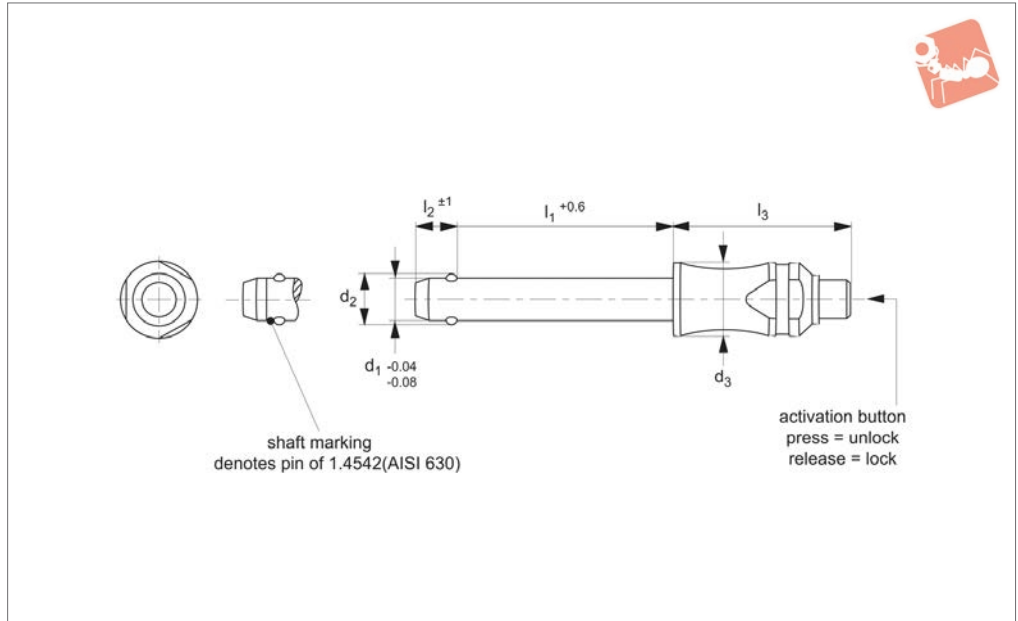

Material

Pin: stainless steel 1.4305 (AISI 303).
Spring: stainless steel.

Technical Notes

Pressing = unlocking.
Releasing = locking.
Single piece contoured design for limited space applications.

Temperature resistance up to 250°C.
For quick fastening and locking of frequently repeated connections.
For suitable lanyards see part no. 33250.
W0970 and .W0974 only. Easy install locating bushes available see part no. 33248.

Tips

Single piece design, no danger of parts coming away from pin - ideal for applications with F.O.B (Foreign Object Body) issues.

Important Notes

*Shearing resistance similar to DIN 50141.

Order No.	Material	d_1	d_2	d_3	l_1	l_2	l_3	Location hole dia. tol. H11	Shearing resistance, double kN min.	Weight g
33194.W0007	Stainless 1.4305	5	5.5	10	45	6.0	26.2	5	14	15
33194.W0008	Stainless 1.4305	5	5.5	10	50	6.0	26.2	5	14	16
33194.W0009	Stainless 1.4305	5	5.5	10	60	6.0	26.2	5	14	17
33194.W0010	Stainless 1.4305	5	5.5	10	70	6.0	26.2	5	14	19
33194.W0011	Stainless 1.4305	5	5.5	10	80	6.0	26.2	5	14	20
33194.W0012	Stainless 1.4305	5	5.5	10	10	6.0	26.2	5	14	10
33194.W0013	Stainless 1.4305	5	5.5	10	15	6.0	26.2	5	14	11
33194.W0014	Stainless 1.4305	5	5.5	10	20	6.0	26.2	5	14	12
33194.W0015	Stainless 1.4305	5	5.5	10	25	6.0	26.2	5	14	13
33194.W0016	Stainless 1.4305	5	5.5	10	30	6.0	26.2	5	14	13
33194.W0017	Stainless 1.4305	5	5.5	10	35	6.0	26.2	5	14	14
33194.W0018	Stainless 1.4305	5	5.5	10	40	6.0	26.2	5	14	15
33194.W0019	Stainless 1.4305	6	7.0	10	60	7.0	26.2	6	21	21
33194.W0020	Stainless 1.4305	6	7.0	10	70	7.0	26.2	6	21	21
33194.W0021	Stainless 1.4305	6	7.0	10	80	7.0	26.2	6	21	25
33194.W0022	Stainless 1.4305	6	7.0	10	10	7.0	26.2	6	21	11
33194.W0023	Stainless 1.4305	6	7.0	10	15	7.0	26.2	6	21	12
33194.W0024	Stainless 1.4305	6	7.0	10	20	7.0	26.2	6	21	13
33194.W0025	Stainless 1.4305	6	7.0	10	25	7.0	26.2	6	21	14
33194.W0026	Stainless 1.4305	6	7.0	10	30	7.0	26.2	6	21	15
33194.W0027	Stainless 1.4305	6	7.0	10	35	7.0	26.2	6	21	16
33194.W0028	Stainless 1.4305	6	7.0	10	40	7.0	26.2	6	21	17
33194.W0029	Stainless 1.4305	6	7.0	10	45	7.0	26.2	6	21	18
33194.W0030	Stainless 1.4305	6	7.0	10	50	7.0	26.2	6	21	19
33194.W0031	Stainless 1.4305	8	9.6	14	60	8.2	33.1	8	38	47
33194.W0032	Stainless 1.4305	8	9.6	14	10	8.2	33.1	8	38	29
33194.W0033	Stainless 1.4305	8	9.6	14	15	8.2	33.1	8	38	31
33194.W0034	Stainless 1.4305	8	9.6	14	20	8.2	33.1	8	38	33

Ball Lock Pins & Quick Release

Ball Lock Pins - Contoured Handle

self-locking - single acting - stainless 1.4305



BALL LOCK PINS & QUICK RELEASE PINS

Order No.	Material	d ₁	d ₂	d ₃	l ₁	l ₂	l ₃	Location hole dia. tol. H11	Shearing resistance, double kN min.	Weight g
33194.W0133	Stainless 1.4305	25	30.8	28	90	22.0	49.9	25	386	545
33194.W0134	Stainless 1.4305	25	30.8	28	100	22.0	49.9	25	386	582
33194.W0135	Stainless 1.4305	25	30.8	28	110	22.0	49.9	25	386	620
33194.W0136	Stainless 1.4305	25	30.8	28	120	22.0	49.9	25	386	657
33194.W0137	Stainless 1.4305	25	30.8	28	130	22.0	49.9	25	386	695
33194.W0138	Stainless 1.4305	25	30.8	28	140	22.0	49.9	25	386	732
33194.W0139	Stainless 1.4305	25	30.8	28	150	22.0	49.9	25	386	770

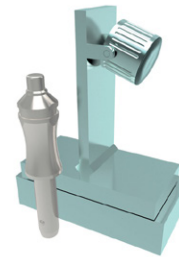
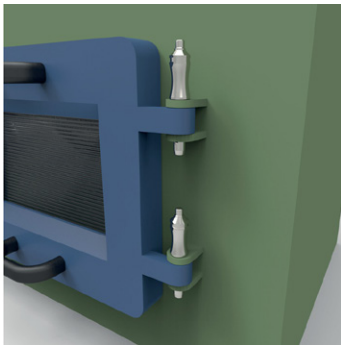



Ball Lock Pins - Contoured Handle

self-locking - single acting - stainless 1.4542

Ball Lock Pins & Quick Release

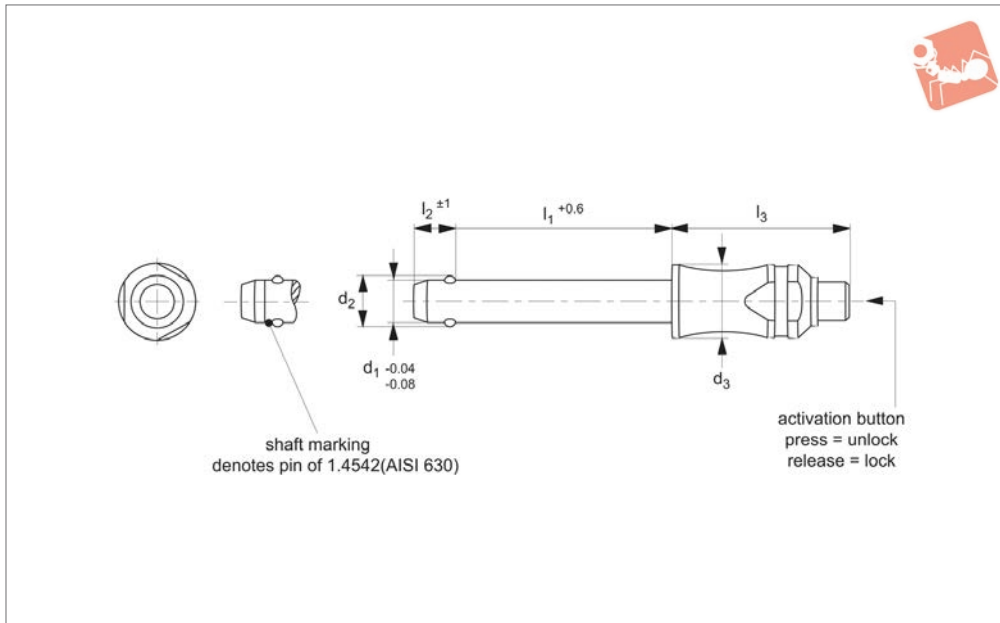

33194.2

BALL LOCK PINS & QUICK RELEASE PINS

Material

Pin: stainless steel 1.4542 (AISI 630), precipitation-hardened, blast finish. Offering extreme load capacity (marked at end of shaft to denote 1.4542 material). End of shaft marked for material type 1.4542.
Spring: stainless steel.

Technical Notes

Pressing = unlocking.

Releasing = locking.

Single piece contoured design for limited space applications.
Temperature resistance up to 250°C.
For quick fastening and locking of frequently repeated connections.
For suitable lanyards see part no. 33250. W0970 and .W0974 only. Easy install locating bushes available see part no. 33248.

Tips

Single piece design, no danger of parts coming away from pin - ideal for applications with F.O.B (Foreign Object Body) issues.

Important Notes

*Shearing resistance similar to DIN 50141.

Order No.	Material	d ₁	d ₂	d ₃	l ₁	l ₂	l ₃	Location hole dia. tol. H11	Shearing resistance, double kN min.	Weight g
33194.W0307	Stainless 1.4542	5	5.5	10	45	6.0	26.2	5	24	15
33194.W0308	Stainless 1.4542	5	5.5	10	50	6.0	26.2	5	24	16
33194.W0309	Stainless 1.4542	5	5.5	10	60	6.0	26.2	5	24	17
33194.W0310	Stainless 1.4542	5	5.5	10	70	6.0	26.2	5	24	20
33194.W0311	Stainless 1.4542	5	5.5	10	80	6.0	26.2	5	24	20
33194.W0312	Stainless 1.4542	5	5.5	10	10	6.0	26.2	5	24	10
33194.W0313	Stainless 1.4542	5	5.5	10	15	6.0	26.2	5	24	11
33194.W0314	Stainless 1.4542	5	5.5	10	20	6.0	26.2	5	24	12
33194.W0315	Stainless 1.4542	5	5.5	10	25	6.0	26.2	5	24	13
33194.W0316	Stainless 1.4542	5	5.5	10	30	6.0	26.2	5	24	13
33194.W0317	Stainless 1.4542	5	5.5	10	35	6.0	26.2	5	24	14
33194.W0318	Stainless 1.4542	5	5.5	10	40	6.0	26.2	5	24	15
33194.W0319	Stainless 1.4542	6	7.0	10	60	7.0	26.2	6	35	21
33194.W0320	Stainless 1.4542	6	7.0	10	70	7.0	26.2	6	35	23
33194.W0321	Stainless 1.4542	6	7.0	10	70	7.0	26.2	6	35	25
33194.W0322	Stainless 1.4542	6	7.0	10	10	7.0	26.2	6	35	11
33194.W0323	Stainless 1.4542	6	7.0	10	15	7.0	26.2	6	35	12
33194.W0324	Stainless 1.4542	6	7.0	10	20	7.0	26.2	6	35	13
33194.W0325	Stainless 1.4542	6	7.0	10	25	7.0	26.2	6	35	14
33194.W0326	Stainless 1.4542	6	7.0	10	30	7.0	26.2	6	35	15
33194.W0327	Stainless 1.4542	6	7.0	10	35	7.0	26.2	6	35	16
33194.W0328	Stainless 1.4542	6	7.0	10	40	7.0	26.2	6	35	17
33194.W0329	Stainless 1.4542	6	7.0	10	45	7.0	26.2	6	35	18
33194.W0330	Stainless 1.4542	6	7.0	10	50	7.0	26.2	6	35	19
33194.W0331	Stainless 1.4542	8	9.6	14	60	8.2	33.1	8	63	47



Ball Lock Pins - Contoured Handle

self-locking - single acting - stainless 1.4542

Ball Lock Pins & Quick Release



Order No.	Material	d ₁	d ₂	d ₃	l ₁	l ₂	l ₃	Location hole dia. tol. H11	Shearing resistance, double kN min.	Weight g
33194.W0434	Stainless 1.4542	25	30.8	28	100	22.0	49.9	25	631	582
33194.W0435	Stainless 1.4542	25	30.8	28	110	22.0	49.9	25	631	620
33194.W0436	Stainless 1.4542	25	30.8	28	120	22.0	49.9	25	631	657
33194.W0438	Stainless 1.4542	25	30.8	28	140	22.0	49.9	25	631	732
33194.W0439	Stainless 1.4542	25	30.8	28	150	22.0	49.9	25	631	770
33194.W3100	Stainless 1.4542	16	19.0	20	120	14.0	39.5	16	257	263
33194.W3101	Stainless 1.4542	16	19.0	20	130	14.0	39.5	16	257	279
33194.W3102	Stainless 1.4542	16	19.0	20	140	14.0	39.5	16	257	295
33194.W3103	Stainless 1.4542	16	19.0	20	150	14.0	39.5	16	257	310

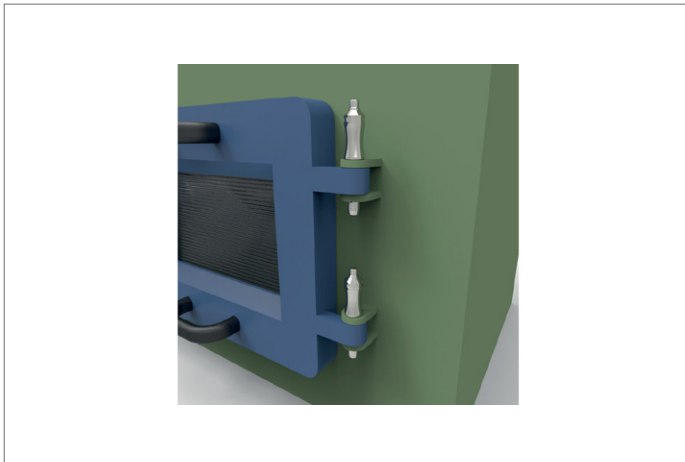

BALL LOCK PINS & QUICK RELEASE PINS



BALL LOCK PINS & QUICK RELEASE PINS



33226.1

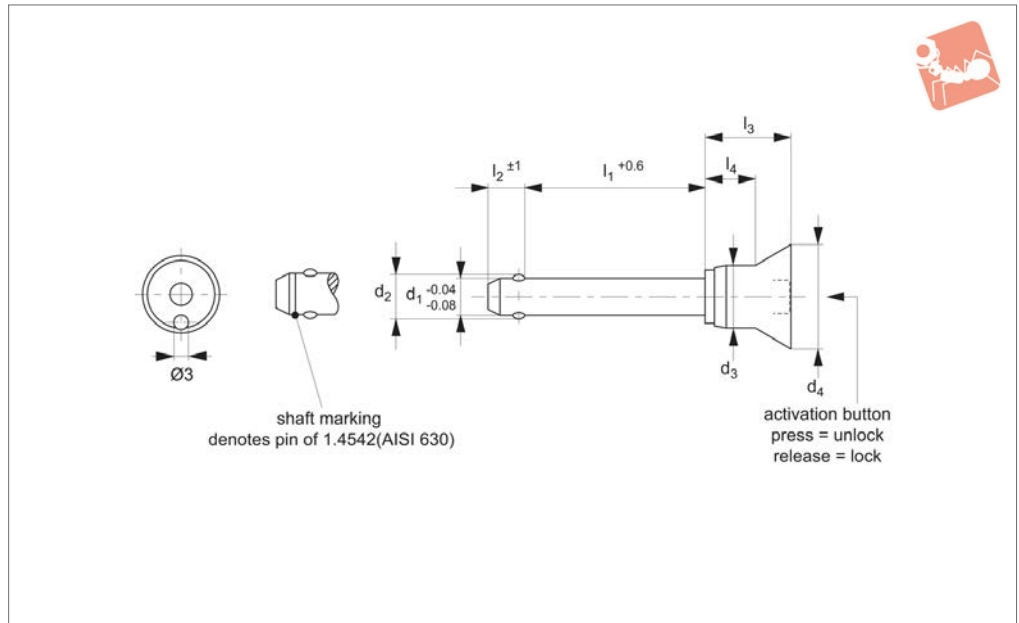

Material

Pin: Stainless steel 1.4305 (AISI 303).
Ball: stainless steel 1.3541
Spring: stainless steel.
Handle: stainless steel.

Technical Notes

Pressing = unlocking.

Releasing = locking.

Handle shape protects against accidental actuation of ball lock pin.

Temperature resistant up to 250°C

For quick fastening and locking of frequently repeated connections.

Tips

For lanyards & retaining cables see part no. 33250. Easy install locating bushes available see part no. 33248.

Important Notes

*Shearing resistance similar to DIN 50141.

Order No.	Material	d ₁	l ₁	d ₂	d ₃	d ₄	l ₂	l ₃	l ₄	Location hole dia.	Shearing resistance, double kN	Weight g
33226.W1012	Stainless 1.4305	5	10	5.5	10.3	20	6.0	21.0	11.6	5	14	18
33226.W1013	Stainless 1.4305	5	15	5.5	10.3	20	6.0	21.0	11.6	5	14	19
33226.W1014	Stainless 1.4305	5	20	5.5	10.3	20	6.0	21.0	11.6	5	14	20
33226.W1015	Stainless 1.4305	5	25	5.5	10.3	20	6.0	21.0	11.6	5	14	21
33226.W1016	Stainless 1.4305	5	30	5.5	10.3	20	6.0	21.0	11.6	5	14	21
33226.W1022	Stainless 1.4305	6	10	7.0	10.3	20	7.0	21.0	11.6	6	21	19
33226.W1023	Stainless 1.4305	6	15	7.0	10.3	20	7.0	21.0	11.6	6	21	20
33226.W1024	Stainless 1.4305	6	20	7.0	10.3	20	7.0	21.0	11.6	6	21	22
33226.W1025	Stainless 1.4305	6	25	7.0	10.3	20	7.0	21.0	11.6	6	21	23
33226.W1026	Stainless 1.4305	6	30	7.0	10.3	20	7.0	21.0	11.6	6	21	24
33226.W1027	Stainless 1.4305	6	35	7.0	10.3	20	7.0	21.0	11.6	6	21	25
33226.W1028	Stainless 1.4305	6	40	7.0	10.3	20	7.0	21.0	11.6	6	21	26
33226.W1029	Stainless 1.4305	6	45	7.0	10.3	20	7.0	21.0	11.6	6	21	27
33226.W1030	Stainless 1.4305	6	50	7.0	10.3	20	7.0	21.0	11.6	6	21	28
33226.W1034	Stainless 1.4305	8	20	9.5	13.3	24	8.2	27.5	17.4	8	38	40
33226.W1035	Stainless 1.4305	8	25	9.5	13.3	24	8.2	27.5	17.4	8	38	41
33226.W1036	Stainless 1.4305	8	30	9.5	13.3	24	8.2	27.5	17.4	8	38	43
33226.W1037	Stainless 1.4305	8	35	9.5	13.3	24	8.2	27.5	17.4	8	38	45
33226.W1038	Stainless 1.4305	8	40	9.5	13.3	24	8.2	27.5	17.4	8	38	47
33226.W1039	Stainless 1.4305	8	45	9.5	13.3	24	8.2	27.5	17.4	8	38	49
33226.W1040	Stainless 1.4305	8	50	9.5	13.3	24	8.2	27.5	17.4	8	38	51
33226.W1044	Stainless 1.4305	10	20	12.0	13.3	24	9.6	27.5	17.4	10	60	46
33226.W1045	Stainless 1.4305	10	25	12.0	13.3	24	9.6	27.5	17.4	10	60	49
33226.W1046	Stainless 1.4305	10	30	12.0	13.3	24	9.6	27.5	17.4	10	60	52
33226.W1047	Stainless 1.4305	10	35	12.0	13.3	24	9.6	27.5	17.4	10	60	5
33226.W1048	Stainless 1.4305	10	40	12.0	13.3	24	9.6	27.5	17.4	10	60	58
33226.W1049	Stainless 1.4305	10	45	12.0	13.3	24	9.6	27.5	17.4	10	60	61
33226.W1050	Stainless 1.4305	10	50	12.0	13.3	24	9.6	27.5	17.4	10	60	64
33226.W1052	Stainless 1.4305	10	60	12.0	13.3	24	9.6	27.5	17.4	10	60	70
33226.W1065	Stainless 1.4305	12	25	14.5	16.5	28	10.6	33.5	23.1	12	87	77



Ball Lock Pins - Single Acting - Safety

self-locking - stainless 1.4305

Ball Lock Pins & Quick Release



Order No.	Material	d ₁	l ₁	d ₂	d ₃	d ₄	l ₂	l ₃	l ₄	Location hole dia.	Shearing resistance, double kN	Weight g
33226.W1066	Stainless 1.4305	12	30	14.5	16.5	28	10.6	33.5	23.1	12	87	82
33226.W1067	Stainless 1.4305	12	35	14.5	16.5	28	10.6	33.5	23.1	12	87	86
33226.W1068	Stainless 1.4305	12	40	14.5	16.5	28	10.6	33.5	23.1	12	87	90
33226.W1069	Stainless 1.4305	12	45	14.5	16.5	28	10.6	33.5	23.1	12	87	94
33226.W1070	Stainless 1.4305	12	50	14.5	16.5	28	10.6	33.5	23.1	12	87	99
33226.W1072	Stainless 1.4305	12	60	14.5	16.5	28	10.6	33.5	23.1	12	87	107
33226.W1074	Stainless 1.4305	12	70	14.5	16.5	28	10.6	33.5	23.1	12	87	116
33226.W1076	Stainless 1.4305	12	80	14.5	16.5	28	10.6	33.5	23.1	12	87	124

BALL LOCK PINS & QUICK RELEASE PINS



33226.2

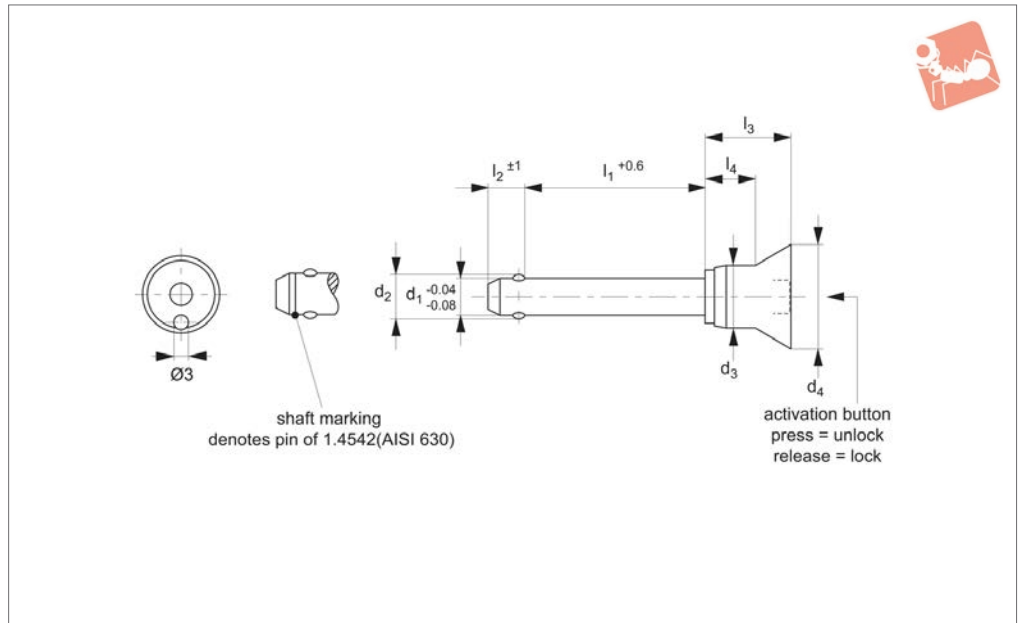

Material

Pin: Stainless steel 1.4542 (AISI 630), precipitation hardened, blast finish. Offering extreme load capacity. (Marked at end of shaft to denote 1.4542 material).
 Ball: stainless steel 1.3541
 Spring: stainless steel.
 Handle: stainless steel.

Technical Notes

Pressing = unlocking.

Releasing = locking.

Handle shape protects against accidental actuation of ball lock pin.
 Temperature resistant up to 250°C
 For quick fastening and locking of frequently repeated connections.

Tips

For lanyards & retaining cables see part no. 33250. Easy install locating bushes

available see part no. 33248.

Important Notes

*Shearing resistance similar to DIN 50141.

Order No.	Material	d ₁	l ₁	d ₂	d ₃	d ₄	l ₂	l ₃	l ₄	Location hole dia.	Shearing resistance, double kN	Weight g
33226.W1512	Stainless 1.4542	5	10	5.5	10.3	20	6.0	21.0	11.6	5	24	18
33226.W1513	Stainless 1.4542	5	15	5.5	10.3	20	6.0	21.0	11.6	5	24	19
33226.W1514	Stainless 1.4542	5	20	5.5	10.3	20	6.0	21.0	11.6	5	24	20
33226.W1515	Stainless 1.4542	5	25	5.5	10.3	20	6.0	21.0	11.6	5	24	21
33226.W1516	Stainless 1.4542	5	30	5.5	10.3	20	6.0	21.0	11.6	5	24	21
33226.W1522	Stainless 1.4542	6	10	7.0	10.3	20	7.0	21.0	11.6	6	35	19
33226.W1523	Stainless 1.4542	6	15	7.0	10.3	20	7.0	21.0	11.6	6	35	20
33226.W1524	Stainless 1.4542	6	20	7.0	10.3	20	7.0	21.0	11.6	6	35	22
33226.W1525	Stainless 1.4542	6	25	7.0	10.3	20	7.0	21.0	11.6	6	35	23
33226.W1526	Stainless 1.4542	6	30	7.0	10.3	20	7.0	21.0	11.6	6	35	24
33226.W1527	Stainless 1.4542	6	35	7.0	10.3	20	7.0	21.0	11.6	6	35	25
33226.W1528	Stainless 1.4542	6	40	7.0	10.3	20	7.0	21.0	11.6	6	35	26
33226.W1529	Stainless 1.4542	6	45	7.0	10.3	20	7.0	21.0	11.6	6	35	27
33226.W1530	Stainless 1.4542	6	50	7.0	10.3	20	7.0	21.0	11.6	6	35	28
33226.W1534	Stainless 1.4542	8	20	9.5	13.3	24	8.2	27.5	17.4	8	63	40
33226.W1535	Stainless 1.4542	8	25	9.5	13.3	24	8.2	27.5	17.4	8	63	41
33226.W1536	Stainless 1.4542	8	30	9.5	13.3	24	8.2	27.5	17.4	8	63	43
33226.W1537	Stainless 1.4542	8	35	9.5	13.3	24	8.2	27.5	17.4	8	63	45
33226.W1538	Stainless 1.4542	8	40	9.5	13.3	24	8.2	27.5	17.4	8	63	47
33226.W1539	Stainless 1.4542	8	45	9.5	13.3	24	8.2	27.5	17.4	8	63	49
33226.W1540	Stainless 1.4542	8	50	9.5	13.3	24	8.2	27.5	17.4	8	63	51
33226.W1544	Stainless 1.4542	10	20	12.0	13.3	24	9.6	27.5	17.4	10	100	46
33226.W1545	Stainless 1.4542	10	25	12.0	13.3	24	9.6	27.5	17.4	10	100	49
33226.W1546	Stainless 1.4542	10	30	12.0	13.3	24	9.6	27.5	17.4	10	100	52
33226.W1547	Stainless 1.4542	10	35	12.0	13.3	24	9.6	27.5	17.4	10	100	55
33226.W1548	Stainless 1.4542	10	40	12.0	13.3	24	9.6	27.5	17.4	10	100	58



Ball Lock Pins - Single Acting - Safety

self-locking - stainless 1.4542

Ball Lock Pins & Quick Release



Order No.	Material	d ₁	l ₁	d ₂	d ₃	d ₄	l ₂	l ₃	l ₄	Location hole dia.	Shearing resistance, double kN	Weight g
33226.W1549	Stainless 1.4542	10	45	12.0	13.3	24	9.6	27.5	17.4	10	100	61
33226.W1550	Stainless 1.4542	10	50	12.0	13.3	24	9.6	27.5	17.4	10	100	64
33226.W1552	Stainless 1.4542	10	60	12.0	13.3	24	9.6	27.5	17.4	10	100	70
33226.W1565	Stainless 1.4542	12	25	14.5	16.5	28	10.6	33.5	23.1	12	144	77
33226.W1566	Stainless 1.4542	12	30	14.5	16.5	28	10.6	33.5	23.1	12	144	82
33226.W1567	Stainless 1.4542	12	35	14.5	16.5	28	10.6	33.5	23.1	12	144	86
33226.W1568	Stainless 1.4542	12	40	14.5	16.5	28	10.6	33.5	23.1	12	144	90
33226.W1569	Stainless 1.4542	12	45	14.5	16.5	28	10.6	33.5	23.1	12	144	94
33226.W1570	Stainless 1.4542	12	50	14.5	16.5	28	10.6	33.5	23.1	12	144	99
33226.W1572	Stainless 1.4542	12	60	14.5	16.5	28	10.6	33.5	23.1	12	144	107
33226.W1574	Stainless 1.4542	12	70	14.5	16.5	28	10.6	33.5	23.1	12	144	116
33226.W1576	Stainless 1.4542	12	80	14.5	16.5	28	10.6	33.5	23.1	12	144	124

BALL LOCK PINS & QUICK RELEASE PINS



33100

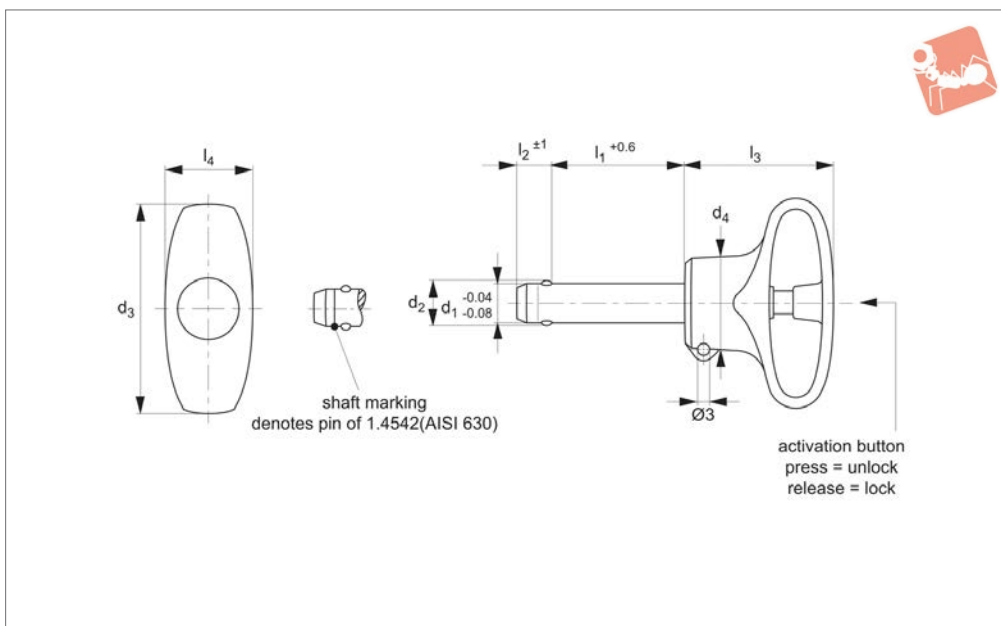

Material

Type One-

Pin: Stainless steel 1.4305 (AISI 303).

Type Two-

Pin: Stainless steel 1.4542 (AISI 630), precipitation hardened, blast finish. Offering extreme load capacity. (Marked at end of shaft to denote 1.4542 material).

Handle: plastic (PBT/TPE). Colours avail.; orange/grey

Technical Notes

Pressing = unlocking.

Releasing = locking.

Unique design; elastic handle provides integral spring action to reset pin (hence no internal spring mechanism required).

Tested to over 100,000+ repetitions.

Temperature resistance -30°C to 80°C.

For quick fastening and locking of frequently repeated connections in applica-

tions such as; sports, leisure, medical and general engineering applications.

Tips

For easy to install locating bush see part **33248 <X\33248#26>**.

Important Notes

*Shearing resistance similar to DIN 50141.

Order No.	Material	d ₁	l ₁	d ₂	d ₃	d ₄	l ₂	l ₃	l ₄	Location hole dia. tol. H11	Shearing resistance, double kN min.	Weight g
33100.W0712	Stainless 1.4305	5	10	5.5	36	12.7	6.0	31.0	15.9	5	14	9
33100.W0713	Stainless 1.4305	5	15	5.5	36	12.7	6.0	31.0	15.9	5	14	10
33100.W0714	Stainless 1.4305	5	20	5.5	36	12.7	6.0	31.0	15.9	5	14	11
33100.W0715	Stainless 1.4305	5	25	5.5	36	12.7	6.0	31.0	15.9	5	14	11
33100.W0716	Stainless 1.4305	5	30	5.5	36	12.7	6.0	31.0	15.9	5	14	12
33100.W0722	Stainless 1.4305	6	10	7.0	36	12.7	7.0	31.0	15.9	6	21	10
33100.W0723	Stainless 1.4305	6	15	7.0	35	12.7	7.0	31.0	15.9	6	21	11
33100.W0724	Stainless 1.4305	6	20	7.0	36	12.7	7.0	31.0	15.9	6	21	12
33100.W0725	Stainless 1.4305	6	25	7.0	36	12.7	7.0	31.0	15.9	6	21	13
33100.W0726	Stainless 1.4305	6	30	7.0	36	12.7	7.0	31.0	15.9	6	21	14
33100.W0727	Stainless 1.4305	6	35	7.0	36	12.7	7.0	31.0	15.9	6	21	15
33100.W0728	Stainless 1.4305	6	40	7.0	36	12.7	7.0	31.0	15.9	6	21	16
33100.W0729	Stainless 1.4305	6	45	7.0	36	12.7	7.0	31.0	15.9	6	21	18
33100.W0730	Stainless 1.4305	6	50	7.0	36	12.7	7.0	31.0	15.9	6	21	18
33100.W0734	Stainless 1.4305	8	20	9.6	41	16.4	8.2	34.8	19.2	8	38	23
33100.W0735	Stainless 1.4305	8	25	9.6	41	16.4	8.2	34.8	19.2	8	38	25
33100.W0736	Stainless 1.4305	8	30	9.6	41	16.4	8.2	34.8	19.2	8	38	26
33100.W0737	Stainless 1.4305	8	35	9.6	41	16.4	8.2	34.8	19.2	8	38	28
33100.W0738	Stainless 1.4305	8	40	9.6	41	16.4	8.2	34.8	19.2	8	38	30
33100.W0739	Stainless 1.4305	8	45	9.6	41	16.4	8.2	34.8	19.2	8	38	32
33100.W0740	Stainless 1.4305	8	50	9.6	41	16.4	8.2	34.8	19.2	8	38	34
33100.W0744	Stainless 1.4305	10	20	12.0	41	16.4	9.6	34.8	19.2	10	60	30
33100.W0745	Stainless 1.4305	10	25	12.0	41	16.4	9.6	34.8	19.2	10	60	32
33100.W0746	Stainless 1.4305	10	30	12.0	41	16.4	9.6	34.8	19.2	10	60	35
33100.W0747	Stainless 1.4305	10	35	12.0	41	16.4	9.6	34.8	19.2	10	60	38
33100.W0748	Stainless 1.4305	10	40	12.0	41	16.4	9.6	34.8	19.2	10	60	41

Ball Lock Pins & Quick Release



Ball Lock Pins - Single Acting - Elastic self-locking



Order No.	Material	d ₁	l ₁	d ₂	d ₃	d ₄	l ₂	l ₃	l ₄	Location hole dia. tol. H11	Shearing resistance, double kN min.	Weight g
33100.W0996	Stainless 1.4542	16	80	19.0	49	21.2	14.0	40.5	24.8	16	257	167

BALL LOCK PINS & QUICK RELEASE PINS

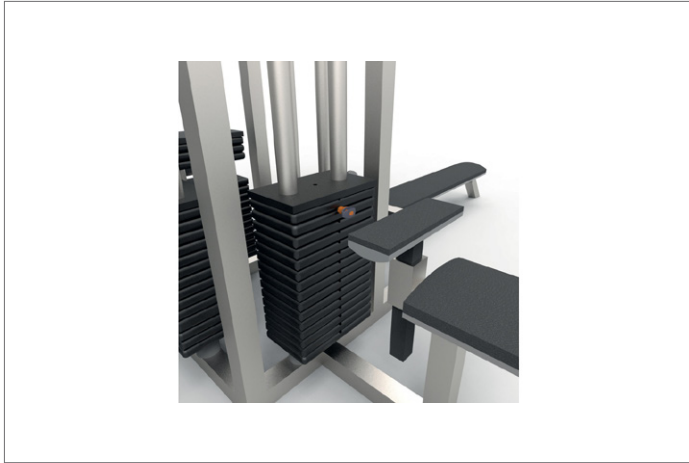



Ball Lock Pins - Contoured Handle

self-locking - single acting - titanium

Ball Lock Pins & Quick Release

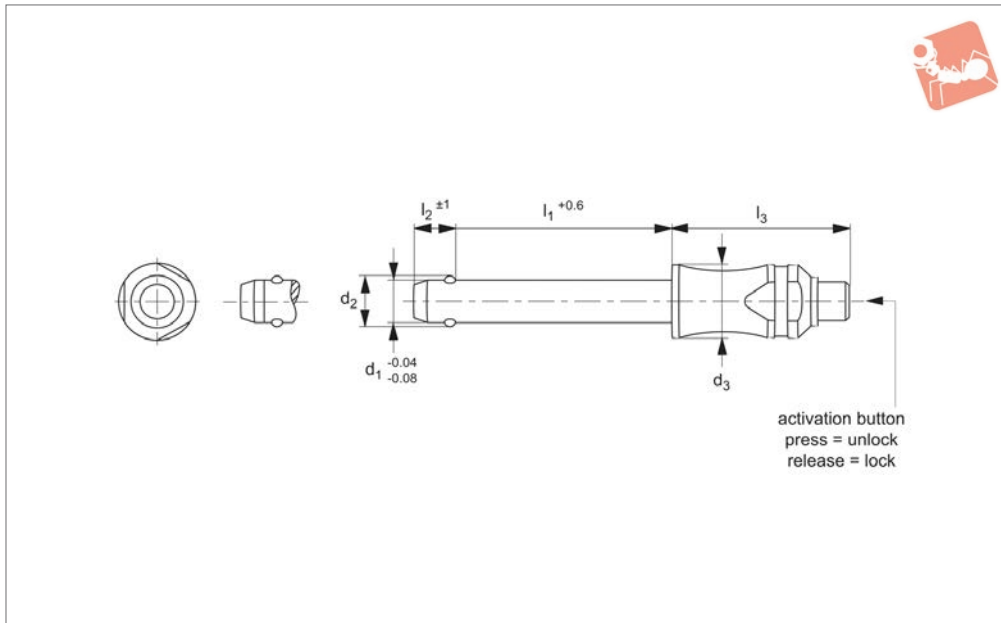

33196

BALL LOCK PINS & QUICK RELEASE PINS

Material

Pin: Titanium G5 (6A/4V DIN 3.7165). Offering extreme load capacity.
Ball: Ceramic.
Spring: Corrosion resistant alloy.

Technical Notes

Pressing = unlocking.
Releasing = locking.
Single piece contoured design for limited

space applications.
Temperature resistance up to 400°C.
For quick fastening and locking of frequently repeated connections.
For suitable lanyards see part no. 33250. W0970 and .W0974 only. Easy install locating bushes available see part no. 33248.

Tips

Single piece design, no danger of parts coming away from pin - ideal for applications with F.O.B (Foreign Object Body) issues.

Important Notes

*Shearing resistance similar to DIN 50141.

Order No.	d ₁	l ₁	d ₂	d ₃	l ₂	l ₃	Location hole dia. tol. H11	Shearing resistance, double kN min.	Weight g
33196.W0022	6	10	7.0	10	7.0	26.2	6	23	7
33196.W0024	6	20	7.0	10	7.0	26.2	6	23	8
33196.W0026	6	30	7.0	10	7.0	26.2	6	23	9
33196.W0028	6	40	7.0	10	7.0	26.2	6	23	10
33196.W0030	6	50	7.0	10	7.0	26.2	6	23	11
33196.W0034	8	20	9.6	14	8.2	33.1	8	43	19
33196.W0036	8	30	9.6	14	8.2	33.1	8	43	21
33196.W0038	8	40	9.6	14	8.2	33.1	8	43	23
33196.W0040	8	50	9.6	14	8.2	33.1	8	43	25
33196.W0044	10	20	12.0	14	9.6	33.1	8	46	23
33196.W0046	10	30	12.0	14	9.6	26.2	10	69	26
33196.W0048	10	40	12.0	14	9.6	26.2	10	69	29
33196.W0050	10	50	12.0	14	9.6	26.2	10	69	32
33196.W0052	10	60	12.0	14	9.6	26.2	10	69	36

Ball Lock Pins & Quick Release



Ball Lock Pins - Contoured Handle

self-locking - single acting - titanium

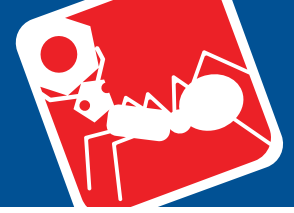

BALL LOCK PINS & QUICK RELEASE PINS

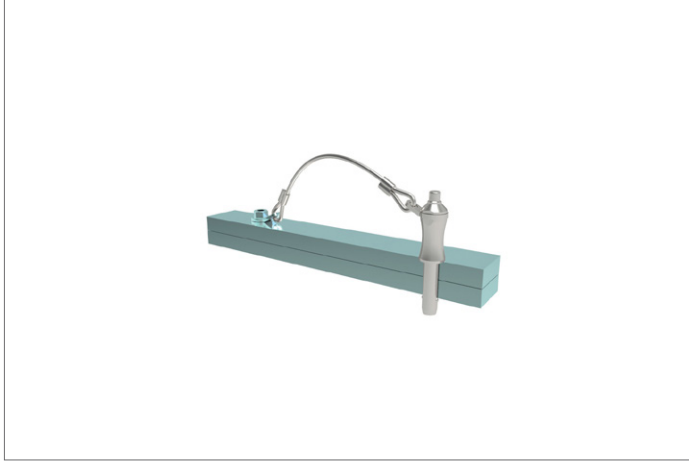



Aviation Pip-Pin - Standard B Handle

single acting - quick release pins

Ball Lock Pins & Quick Release

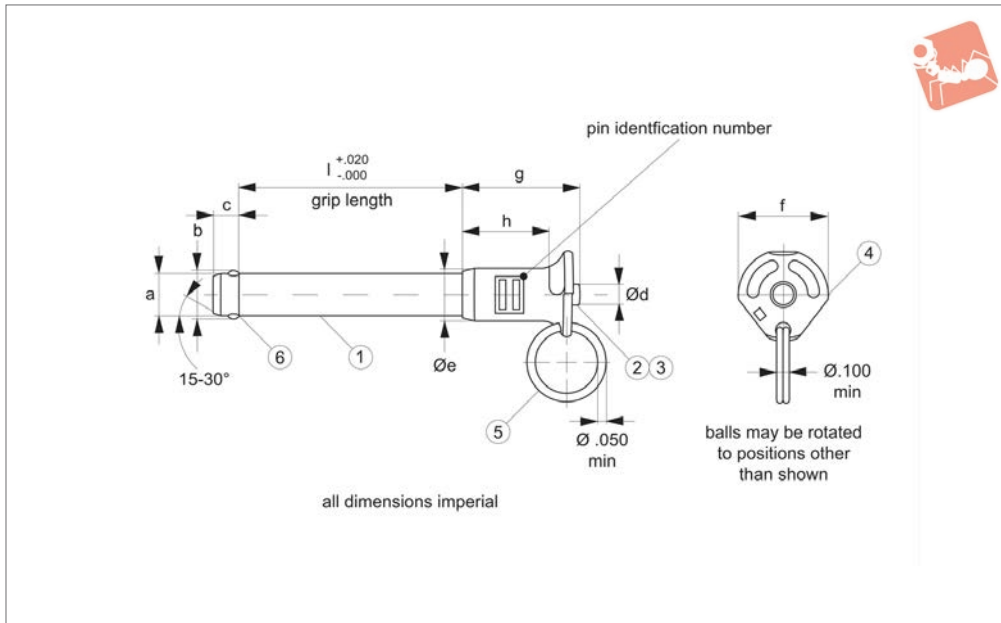

33600

BALL LOCK PINS & QUICK RELEASE PINS

Material

Shank (part 1) & Spindle (part 2):

CRES 17-4PH (AMS 5643), heat treated per MIL-H-6875, condition H900, min. 40 HRC, passivated per AMS2700

Spring (part 3, not shown):

CRES 302 (ASTM-A-313), heat treated per MIL-H-6875, passivated per AMS2700

Handle (part 4):

A380 (QQ-A-591), anodized (black) per MIL-A-8625

Attaching ring (part 5):

CRES 302 (ASTM-A-313), passivated per AMS2700

Ball (locking element, part 6):

CRES CL440C (AMS5630), heat treated per MIL-H-6875, passivated per AMS2700

Technical Notes

Wixroyd Aviation Pip-Pins manufactured to Aviation Norm NASM 17984 (former norm: MS 17984) and tested to NAS 1332.

Manufacture certified & assessed to EN9100D by EASE (European Aerospace Supplier Evaluation).

Temp. range -22°F to 302°F

Pressing = unlocking.

Releasing = locking.

Pip-Pins are used for frequently repeated operations such as quick fastening, locking, adjusting, changing and securing. All dimensions shown are imperial.

Tips

We can manufacture specials (both metric & imperial) to your drawing, and are certified to produce to NASM standards.

Wixroyd Aviation Pip-Pins can be produced within the following dimensions:

+ diameter: from 3/16" to 1"

+ grip length: from 0.3" to 9.9"

Quick production time on small batches.

Order No.	Dia. Ø nom.	Grip l	b	c	Ø d max.	Ø e max.	Weight g
33600.A005	3/16	0.5	0.220	0.26	0.31	0.44	17
33600.A006	3/16	0.6	0.220	0.26	0.31	0.44	17
33600.A007	3/16	0.7	0.220	0.26	0.31	0.44	17
33600.A008	3/16	0.8	0.220	0.26	0.31	0.44	18
33600.A010	3/16	1.0	0.220	0.26	0.31	0.44	18
33600.A011	3/16	1.1	0.220	0.26	0.31	0.44	19
33600.A013	3/16	1.3	0.220	0.26	0.31	0.44	19
33600.A015	3/16	1.5	0.220	0.26	0.31	0.44	20
33600.A018	3/16	1.8	0.220	0.26	0.31	0.44	21
33600.A020	3/16	2.0	0.220	0.26	0.31	0.44	22
33600.B007	1/4	0.7	0.289	0.29	0.31	0.44	20
33600.B008	1/4	0.8	0.289	0.29	0.31	0.44	20
33600.B010	1/4	1.0	0.289	0.29	0.31	0.44	22
33600.B011	1/4	1.1	0.289	0.29	0.31	0.44	22
33600.B012	1/4	1.2	0.289	0.29	0.31	0.44	24
33600.B014	1/4	1.4	0.289	0.29	0.31	0.44	24
33600.B018	1/4	1.8	0.289	0.29	0.31	0.44	26
33600.B019	1/4	1.9	0.289	0.29	0.31	0.44	27
33600.B020	1/4	2.0	0.289	0.29	0.31	0.44	27
33600.B023	1/4	2.3	0.289	0.29	0.31	0.44	29
33600.B025	1/4	2.5	0.289	0.29	0.31	0.44	32



Order No.	Dia. Ø nom.	Grip l	b	c	Ø d max.	Ø e max.	Weight g
33600.B028	1/4	2.8	0.289	0.29	0.31	0.44	32
33600.B029	1/4	2.9	0.289	0.29	0.31	0.44	33
33600.B064	1/4	6.4	0.289	0.29	0.31	0.44	59
33600.C008	5/16	0.8	0.375	0.33	0.31	0.49	25
33600.C010	5/16	1.0	0.375	0.33	0.31	0.49	28
33600.C012	5/16	1.2	0.375	0.33	0.31	0.49	29
33600.C014	5/16	1.4	0.375	0.33	0.31	0.49	31
33600.C016	5/16	1.6	0.375	0.33	0.31	0.49	33
33600.C017	5/16	1.7	0.375	0.33	0.31	0.49	34
33600.C019	5/16	1.9	0.375	0.33	0.31	0.49	33
33600.C020	5/16	2.0	0.375	0.33	0.31	0.49	36
33600.C022	5/16	2.2	0.375	0.33	0.31	0.49	38
33600.C023	5/16	2.3	0.375	0.33	0.31	0.49	39
33600.C025	5/16	2.5	0.375	0.33	0.31	0.49	43
33600.C029	5/16	2.9	0.375	0.33	0.31	0.49	46
33600.C030	5/16	3.0	0.375	0.33	0.31	0.49	47
33600.C036	5/16	3.6	0.375	0.33	0.31	0.49	53
33600.C049	5/16	4.9	0.375	0.33	0.31	0.49	65
33600.C062	5/16	6.2	0.375	0.33	0.31	0.49	73
33600.C067	5/16	6.7	0.375	0.33	0.31	0.49	85

Order No.	Ø f max.	g max.	h min.	Shearing resistance, double lb min.	Location hole dia. max.	MS Part No.
33600.A005	0.800	0.83	0.48	5.150	0.1940	MS17984C305
33600.A006	0.800	0.83	0.48	5.150	0.1940	MS17984C306
33600.A007	0.800	0.83	0.48	5.150	0.1940	MS17984C307
33600.A008	0.800	0.83	0.48	5.150	0.1940	MS17984C308
33600.A010	0.800	0.83	0.48	5.150	0.1940	MS17984C310
33600.A011	0.800	0.83	0.48	5.150	0.1940	MS17984C311
33600.A013	0.800	0.83	0.48	5.150	0.1940	MS17984C313
33600.A015	0.800	0.83	0.48	5.150	0.1940	MS17984C315
33600.A018	0.800	0.83	0.48	5.150	0.1940	MS17984C318
33600.A020	0.800	0.83	0.48	5.150	0.1940	MS17984C320
33600.B007	0.800	0.89	0.48	9.200	0.2540	MS17984C407
33600.B008	0.800	0.89	0.48	9.200	0.2540	MS17984C408
33600.B010	0.800	0.89	0.48	9.200	0.2540	MS17984C410
33600.B011	0.800	0.89	0.48	9.200	0.2540	MS17984C411
33600.B012	0.800	0.89	0.48	9.200	0.2540	MS17984C412
33600.B014	0.800	0.89	0.48	9.200	0.2540	MS17984C414
33600.B018	0.800	0.89	0.48	9.200	0.2540	MS17984C418
33600.B019	0.800	0.89	0.48	9.200	0.2540	MS17984C419
33600.B020	0.800	0.89	0.48	9.200	0.2540	MS17984C410
33600.B023	0.800	0.89	0.48	9.200	0.2540	MS17984C423
33600.B025	0.800	0.89	0.48	9.200	0.2540	MS17984C425
33600.B028	0.800	0.89	0.48	9.200	0.2540	MS17984C428
33600.B029	0.800	0.89	0.48	9.200	0.2540	MS17984C429
33600.B064	0.800	0.89	0.48	9.200	0.2540	MS17984C464
33600.C008	1.135	0.93	0.48	14.400	0.3165	MS17984C508
33600.C010	1.135	0.93	0.48	14.400	0.3165	MS17984C510
33600.C012	1.135	0.93	0.48	14.400	0.3165	MS17984C512
33600.C014	1.135	0.93	0.48	14.400	0.3165	MS17984C514
33600.C016	1.135	0.93	0.48	14.400	0.3165	MS17984C516
33600.C017	1.135	0.93	0.48	14.400	0.3165	MS17984C517
33600.C019	1.135	0.93	0.48	14.400	0.3165	MS17984C519
33600.C020	1.135	0.93	0.48	14.400	0.3165	MS17984C520
33600.C022	1.135	0.93	0.48	14.400	0.3165	MS17984C522
33600.C023	1.135	0.93	0.48	14.400	0.3165	MS17984C523
33600.C025	1.135	0.93	0.48	14.400	0.3165	MS17984C525
33600.C029	1.135	0.93	0.48	14.400	0.3165	MS17984C529
33600.C030	1.135	0.93	0.48	14.400	0.3165	MS17984C530
33600.C036	1.135	0.93	0.48	14.400	0.3165	MS17984C536
33600.C049	1.135	0.93	0.48	14.400	0.3165	MS17984C549
33600.C062	1.135	0.93	0.48	14.400	0.3165	MS17984C562
33600.C067	1.135	0.93	0.48	14.400	0.3165	MS17984C567



Aviation Pip-Pin - Standard T-Handle

single acting - quick release pins - according to

Ball Lock Pins & Quick Release

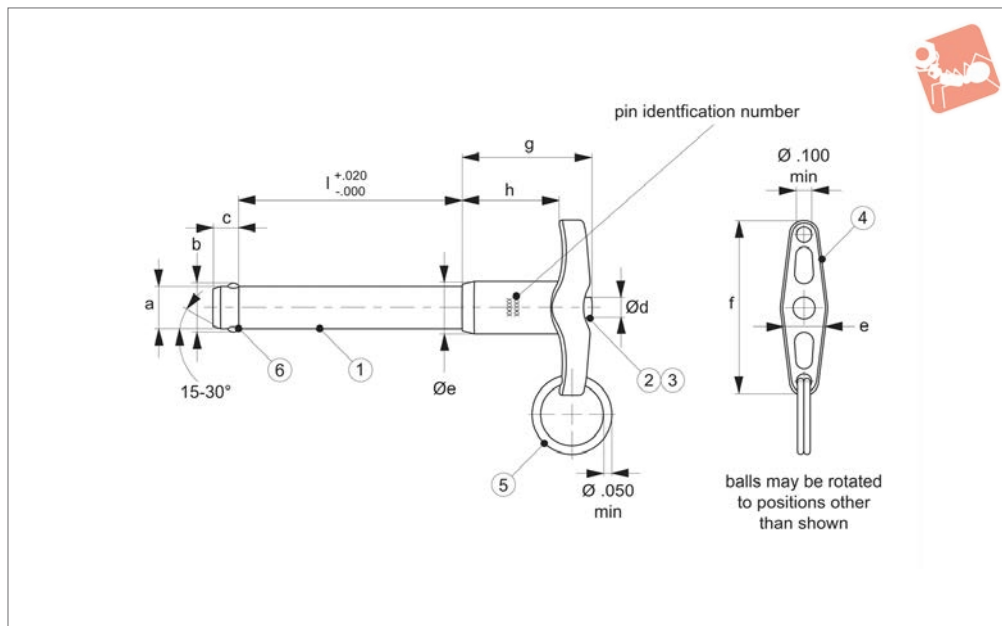

33610

BALL LOCK PINS & QUICK RELEASE PINS

Material

Shank (part 1) & spindle (part 2):

CRES 17-4PH (AMS 5643), heat treated per MIL-H-6875, condition H900, min. 40 HRC, passivated per AMS2700.

Spring (part 3, not shown):

CRES 302 (ASTM-A-313), heat treated per MIL-H-6875, passivated per AMS2700.

Handle (part 4):

A380 (QQ-A-591), anodized (black) per MIL-A-8625.

Attaching ring (part 5):

CRES 302 (ASTM-A-313), passivated per AMS2700.

Ball (locking element, part 6):

CRES CL440C (AMS5630), heat treated per MIL-H-6875, passivated per AMS2700.

Technical Notes

Wixroyd Aviation Pip-pins manufactured to Aviation Norm NASM 17985 (former norm: MS 17985) and tested to NAS 1332.

Manufacture certified & assessed to EN9100D by EASE (European Aerospace Supplier Evaluation).

Temp. range -22°F to 302°F

Pressing = unlocking.

Releasing = locking.

Pip-pins are used for frequently repeated operations such as quick fastening, locking, adjusting, changing and securing. All dimensions shown are imperial.

Tips

We can manufacture specials (both metric & imperial) to your drawing, and are certified to produce to NASM standards.

Wixroyd Aviation Pip-Pins can be produced within the following dimensions:

+ diameter: from 3/16" to 1"

+ grip length: from 0.3" to 9.9"

Quick production time on small batches.

Order No.	Dia. \varnothing inch nom.	Grip l inch	b_1	c_1	$\varnothing d$ max.	$\varnothing e$ max.	Weight g
33610.A003	3/16	0.3	,220	,260	,310	0.500	24
33610.A005	3/16	0.5	,220	,260	,310	0.500	24
33610.A008	3/16	0.8	,220	,260	,310	0.500	25
33610.A012	3/16	1.2	,220	,260	,310	0.500	26
33610.A013	3/16	1.3	,220	,260	,310	0.500	27
33610.A014	3/16	1.4	,220	,260	,310	0.500	27
33610.A026	3/16	2.6	,220	,260	,310	0.500	33
33610.B005	1/4	0.5	,289	,290	,310	0.500	26
33610.B009	1/4	0.9	,289	,290	,310	0.500	27
33610.B011	1/4	1.1	,289	,290	,310	0.500	28
33610.B012	1/4	1.2	,289	,290	,310	0.500	30
33610.B013	1/4	1.3	,289	,290	,310	0.500	30
33610.B015	1/4	1.5	,289	,290	,310	0.500	32
33610.B016	1/4	1.6	,289	,290	,310	0.500	33
33610.B021	1/4	2.1	,289	,290	,310	0.500	36
33610.B026	1/4	2.6	,289	,290	,310	0.500	40
33610.B028	1/4	2.8	,289	,290	,310	0.500	41
33610.B040	1/4	4.0	,289	,290	,310	0.500	49
33610.C003	5/16	0.3	,375	,330	,310	0.500	27
33610.C006	5/16	0.6	,375	,330	,310	0.500	30



BALL LOCK PINS & QUICK RELEASE PINS

Order No.	Dia. Ø inch nom.	Grip l inch	b ₁	c ₁	Ø d max.	Ø e max.	Weight g
33610.C010	5/16	1.0	,375	,330	,310	0.500	34
33610.C013	5/16	1.3	,375	,330	,310	0.500	36
33610.C015	5/16	1.5	,375	,330	,310	0.500	39
33610.C016	5/16	1.6	,375	,330	,310	0.500	39
33610.C018	5/16	1.8	,375	,330	,310	0.500	41
33610.C020	5/16	2.0	,375	,330	,310	0.500	43
33610.C023	5/16	2.3	,375	,330	,310	0.500	45
33610.C029	5/16	2.9	,375	,330	,310	0.500	52
33610.C030	5/16	3.0	,375	,330	,310	0.500	53
33610.C033	5/16	3.3	,375	,330	,310	0.500	56
33610.C040	5/16	4.0	,375	,330	,310	0.500	62
33610.C050	5/16	5.0	,375	,330	,310	0.500	75
33610.C064	5/16	6.4	,375	,330	,310	0.500	89
33610.C070	5/16	7.0	,375	,330	,310	0.500	93
33610.D005	3/8	0.5	,440	,365	,390	0.625	43
33610.D010	3/8	1.0	,440	,365	,390	0.625	48
33610.D012	3/8	1.2	,440	,365	,390	0.625	55
33610.D015	3/8	1.5	,440	,365	,390	0.625	57
33610.D016	3/8	1.6	,440	,365	,390	0.625	58
33610.D020	3/8	2.0	,440	,365	,390	0.625	60
33610.D024	3/8	2.4	,440	,365	,390	0.625	69
33610.D025	3/8	2.5	,440	,365	,390	0.625	72
33610.D026	3/8	2.6	,440	,365	,390	0.625	72
33610.D028	3/8	2.8	,440	,365	,390	0.625	72
33610.D031	3/8	3.1	,440	,365	,390	0.625	80
33610.D032	3/8	3.2	,440	,365	,390	0.625	80
33610.D035	3/8	3.5	,440	,365	,390	0.625	85
33610.D040	3/8	4.0	,440	,365	,390	0.625	91
33610.D045	3/8	4.5	,440	,365	,390	0.625	100
33610.E012	7/16	1.2	,509	,380	,390	0.625	60
33610.E018	7/16	1.8	,509	,380	,390	0.625	69
33610.E023	7/16	2.3	,509	,380	,390	0.625	82
33610.E024	7/16	2.4	,509	,380	,390	0.625	80
33610.E026	7/16	2.6	,509	,380	,390	0.625	90
33610.E029	7/16	2.9	,509	,380	,390	0.625	93
33610.E040	7/16	4.0	,509	,380	,390	0.625	113
33610.E042	7/16	4.2	,509	,380	,390	0.625	117
33610.E055	7/16	5.5	,509	,380	,390	0.625	145
33610.E072	1/2	7.2	,594	,460	,390	0.625	176
33610.F010	1/2	1.0	,594	,460	,565	0.800	82
33610.F012	1/2	1.2	,594	,460	,565	0.800	87
33610.F014	1/2	1.4	,594	,460	,565	0.800	94
33610.F015	1/2	1.5	,594	,460	,565	0.800	94
33610.F019	1/2	1.9	,594	,460	,565	0.800	106
33610.F020	1/2	2.0	,594	,460	,565	0.800	108
33610.F024	1/2	2.4	,594	,460	,565	0.800	117
33610.F029	1/2	2.9	,594	,460	,565	0.800	130
33610.F031	1/2	3.1	,594	,460	,565	0.800	135
33610.F036	1/2	3.6	,594	,460	,565	0.800	147
33610.F037	1/2	3.7	,594	,460	,565	0.800	146
33610.F040	1/2	4.0	,594	,460	,565	0.800	156
33610.F047	1/2	4.7	,594	,460	,565	0.800	177
33610.F048	1/2	4.8	,594	,460	,565	0.800	179
33610.F064	1/2	6.4	,594	,460	,565	0.800	218
33610.G017	9/16	1.7	,666	,510	,565	0.800	120
33610.G032	9/16	3.2	,666	,510	,565	0.800	160
33610.G036	9/16	3.6	,666	,510	,565	0.800	176
33610.G040	9/16	4.0	,666	,510	,565	0.800	190
33610.G061	9/16	6.1	,666	,510	,565	0.800	252

Order No.	Ø f max.	g ₁	h ₁	Shearing resistance, double lb min.	Location hole dia. max.	MS Part No.
33610.A003	1.815	1.27	0.800	5.150	0.1940	MS17985C303
33610.A005	1.815	1.27	0.800	5.150	0.1940	MS17985C305
33610.A008	1.815	1.27	0.800	5.150	0.1940	MS17985C308
33610.A012	1.815	1.27	0.800	5.150	0.1940	MS17985C312



Aviation Pip-Pin - Standard T-Handle

single acting - quick release pins - **according to**

Ball Lock Pins & Quick Release

Order No.	Ø f max.	g ₁	h ₁	Shearing resistance, double lb min.	Location hole dia. max.	MS Part No.
33610.A013	1.815	1.27	0.800	5.150	0.1940	MS17985C313
33610.A014	1.815	1.27	0.800	5.150	0.1940	MS17985C314
33610.A026	1.815	1.27	0.800	5.150	0.1940	MS17985C326
33610.B005	1.815	1.27	0.800	9.200	0.2540	MS17985C405
33610.B009	1.815	1.27	0.800	9.200	0.2540	MS17985C409
33610.B011	1.815	1.27	0.800	9.200	0.2540	MS17985C411
33610.B012	1.815	1.27	0.800	9.200	0.2540	MS17985C412
33610.B013	1.815	1.27	0.800	9.200	0.2540	MS17985C413
33610.B015	1.815	1.27	0.800	9.200	0.2540	MS17985C415
33610.B016	1.815	1.27	0.800	9.200	0.2540	MS17985C416
33610.B021	1.815	1.27	0.800	9.200	0.2540	MS17985C421
33610.B026	1.815	1.27	0.800	9.200	0.2540	MS17985C426
33610.B028	1.815	1.27	0.800	9.200	0.2540	MS17985C428
33610.B040	1.815	1.27	0.800	9.200	0.2540	MS17985C440
33610.C003	1.815	1.27	0.800	14.400	0.3165	MS17985C503
33610.C006	1.815	1.27	0.800	14.400	0.3165	MS17985C506
33610.C010	1.815	1.27	0.800	14.400	0.3165	MS17985C510
33610.C013	1.815	1.27	0.800	14.400	0.3165	MS17985C513
33610.C015	1.815	1.27	0.800	14.400	0.3165	MS17985C515
33610.C016	1.815	1.27	0.800	14.400	0.3165	MS17985C516
33610.C018	1.815	1.27	0.800	14.400	0.3165	MS17985C518
33610.C020	1.815	1.27	0.800	14.400	0.3165	MS17985C520
33610.C023	1.815	1.27	0.800	14.400	0.3165	MS17985C523
33610.C029	1.815	1.27	0.800	14.400	0.3165	MS17985C529
33610.C030	1.815	1.27	0.800	14.400	0.3165	MS17985C530
33610.C033	1.815	1.27	0.800	14.400	0.3165	MS17985C533
33610.C040	1.815	1.27	0.800	14.400	0.3165	MS17985C540
33610.C050	1.815	1.27	0.800	14.400	0.3165	MS17985C550
33610.C064	1.815	1.27	0.800	14.400	0.3165	MS17985C564
33610.C070	1.815	1.27	0.800	14.400	0.3165	MS17985C570
33610.D005	2.065	1.45	0.850	20.700	0.3790	MS17985C605
33610.D010	2.065	1.45	0.850	20.700	0.3790	MS17985C610
33610.D012	2.065	1.45	0.850	20.700	0.3790	MS17985C612
33610.D015	2.065	1.45	0.850	20.700	0.3790	MS17985C615
33610.D016	2.065	1.45	0.850	20.700	0.3790	MS17985C616
33610.D020	2.065	1.45	0.850	20.700	0.3790	MS17985C620
33610.D024	2.065	1.45	0.850	20.700	0.3790	MS17985C624
33610.D025	2.065	1.45	0.850	20.700	0.3790	MS17985C625
33610.D026	2.065	1.45	0.850	20.700	0.3790	MS17985C626
33610.D028	2.065	1.45	0.850	20.700	0.3790	MS17985C628
33610.D031	2.065	1.45	0.850	20.700	0.3790	MS17985C631
33610.D032	2.065	1.45	0.850	20.700	0.3790	MS17985C632
33610.D035	2.065	1.45	0.850	20.700	0.3790	MS17985C635
33610.D040	2.065	1.45	0.850	20.700	0.3790	MS17985C640
33610.D045	2.065	1.45	0.850	20.700	0.3790	MS17985C645
33610.E012	2.065	1.47	0.850	28.500	0.4425	MS17985C712
33610.E018	2.065	1.47	0.850	28.500	0.4425	MS17985C718
33610.E023	2.065	1.47	0.850	28.500	0.4425	MS17985C723
33610.E024	2.065	1.47	0.850	28.500	0.4425	MS17985C724
33610.E026	2.065	1.47	0.850	28.500	0.4425	MS17985C726
33610.E029	2.065	1.47	0.850	28.500	0.4425	MS17985C729
33610.E040	2.065	1.47	0.850	28.500	0.4425	MS17985C740
33610.E042	2.065	1.47	0.850	28.500	0.4425	MS17985C742
33610.E055	2.065	1.47	0.850	28.500	0.4425	MS17985C755
33610.E072	2.345	1.60	0.850	36.900	0.5050	MS17985C772
33610.F010	2.345	1.60	0.885	36.900	0.5050	MS17985C810
33610.F012	2.345	1.60	0.885	36.900	0.5050	MS17985C812
33610.F014	2.345	1.60	0.885	36.900	0.5050	MS17985C814
33610.F015	2.345	1.60	0.885	36.900	0.5050	MS17985C815
33610.F019	2.345	1.60	0.885	36.900	0.5050	MS17985C819
33610.F020	2.345	1.60	0.885	36.900	0.5050	MS17985C820
33610.F024	2.345	1.60	0.885	36.900	0.5050	MS17985C824
33610.F029	2.345	1.60	0.885	36.900	0.5050	MS17985C829
33610.F031	2.345	1.60	0.885	36.900	0.5050	MS17985C831
33610.F036	2.345	1.60	0.885	36.900	0.5050	MS17985C836
33610.F037	2.345	1.60	0.885	36.900	0.5050	MS17985C837
33610.F040	2.345	1.60	0.885	36.900	0.5050	MS17985C840

BALL LOCK PINS & QUICK RELEASE PINS

Ball Lock Pins & Quick Release



Aviation Pip-Pin - Standard T-Handle single acting - quick release pins - according to



BALL LOCK PINS & QUICK RELEASE PINS

Order No.	Ø f max.	g ₁	h ₁	Shearing resistance, double lb min.	Location hole dia. max.	MS Part No.
33610.F047	2.345	1.60	0.885	36.900	0.5050	MS17985C847
33610.F048	2.345	1.60	0.885	36.900	0.5050	MS17985C848
33610.F064	2.345	1.60	0.885	36.900	0.5050	MS17985C864
33610.G017	2.345	1.60	0.885	46.700	0.5675	MS17985C917
33610.G032	2.345	1.60	0.885	46.700	0.5675	MS17985C932
33610.G036	2.345	1.60	0.885	46.700	0.5675	MS17985C936
33610.G040	2.345	1.60	0.885	46.700	0.5675	MS17985C940
33610.G061	2.345	1.60	0.885	46.700	0.5675	MS17985C961



Aviation Pip-Pin, Standard LA Handle

single acting, quick release pins - according to

Ball Lock Pins & Quick Release

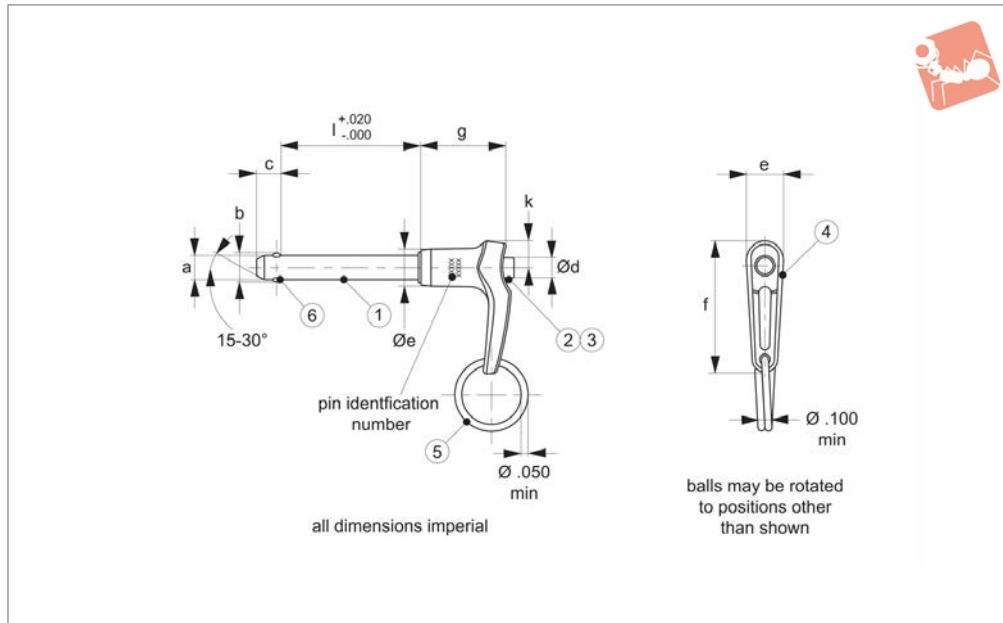

33620

BALL LOCK PINS & QUICK RELEASE PINS

Material

Shank (part 1) & spindle (part 2):

CRES 17-4PH (AMS 5643), heat treated per MIL-H-6875, condition H900, min. 40 HRC, passivated per AMS2700.

Spring (part 3, not shown):

CRES 302 (ASTM-A-313), heat treated per MIL-H-6875, passivated per AMS2700.

Handle (part 4):

A380 (QQ-A-591), anodized (black) per MIL-A-8625.

Attaching ring (part 5):

CRES 302 (ASTM-A-313), passivated per AMS2700.

Ball (locking element, part 6):

CRES CL440C (AMS5630), heat treated per MIL-H-6875, passivated per AMS2700.

Technical Notes

Wixroyd Aviation Pip-pins manufactured to Aviation Norm NASM 17986 (former norm: MS 17986) and tested to NAS 1332.

Manufacture certified & assessed to EN9100D by EASE (European Aerospace Supplier Evaluation).

Temp. range -22°F to 302°F

Pressing = unlocking.

Releasing = locking.

Pip-pins are used for frequently repeated operations such as quick fastening, locking, adjusting, changing and securing. All dimensions shown are imperial.

Tips

We can manufacture specials (both metric & imperial) to your drawing, and are certified to produce to NASM standards.

Wixroyd Aviation Pip-Pins can be produced within the following dimensions:

+ diameter: from 3/16" to 1"

+ grip length: from 0.3" to 9.9"

Quick production time on small batches.

Order No.	Dia. Ø nom.	Grip l	b	c	Ø d max.	Ø e max.	Weight g
33620.A005	3/16	0.5	,594	,460	,565	0.500	23
33620.A008	3/16	0.8	,594	,460	,565	0.500	26
33620.A010	3/16	1.0	,594	,460	,565	0.500	26
33620.A013	3/16	1.3	,594	,460	,565	0.500	28
33620.A014	3/16	1.4	,594	,460	,565	0.500	28
33620.A017	3/16	1.7	,594	,460	,565	0.500	27
33620.B012	1/4	1.2	,594	,460	,565	0.500	32
33620.B015	1/4	1.5	,594	,460	,565	0.500	33
33620.B017	1/4	1.7	,594	,460	,565	0.500	34
33620.B016	1/4	1.6	,594	,460	,565	0.500	33
33620.B021	1/4	2.1	,594	,460	,565	0.500	36
33620.C004	5/16	0.4	,594	,460	,565	0.500	29
33620.C006	5/16	0.6	,594	,460	,565	0.500	30
33620.C010	5/16	1.0	,594	,460	,565	0.500	34
33620.C013	5/16	1.3	,594	,460	,565	0.500	37
33620.C016	5/16	1.6	,594	,460	,565	0.500	40
33620.C018	5/16	1.8	,594	,460	,565	0.500	43
33620.C020	5/16	2.0	,594	,460	,565	0.500	41
33620.C023	5/16	2.3	,594	,460	,565	0.500	46
33620.C029	5/16	2.9	,594	,460	,565	0.500	54
33620.C030	5/16	3.0	,594	,460	,565	0.500	53

Ball Lock Pins & Quick Release

Aviation Pip-Pin, Standard LA Handle

single acting, quick release pins - according to



BALL LOCK PINS & QUICK RELEASE PINS

Order No.	Dia. Ø nom.	Grip l	b	c	Ø d max.	Ø e max.	Weight g
33620.C033	5/16	3.3	,594	,460	,565	0.500	57
33620.C036	5/16	3.6	,594	,460	,565	0.500	60
33620.C040	5/16	4.0	,594	,460	,565	0.500	64
33620.D010	3/8	1.0	,594	,460	,565	0.625	49
33620.D015	3/8	1.5	,594	,460	,565	0.625	59
33620.D020	3/8	2.0	,594	,460	,565	0.625	65
33620.D024	3/8	2.4	,594	,460	,565	0.625	71
33620.D026	3/8	2.6	,594	,460	,565	0.625	73
33620.D030	3/8	3.0	,594	,460	,565	0.625	72
33620.D060	3/8	6.0	,594	,460	,565	0.625	122
33620.E012	7/16	1.2	,594	,460	,565	0.625	61
33620.E035	7/16	3.5	,594	,460	,565	0.625	-
33620.E040	7/16	4.0	,594	,460	,565	0.625	115
33620.E055	7/16	5.5	,594	,460	,565	0.625	146
33620.F010	1/2	1.0	,594	,460	,565	0.800	83
33620.F015	1/2	1.5	,594	,460	,565	0.800	95
33620.F019	1/2	1.9	,594	,460	,565	0.800	103
33620.F034	1/2	3.4	,594	,460	,565	0.800	143
33620.F042	1/2	4.2	,594	,460	,565	0.800	160
33620.F045	1/2	4.5	,594	,460	,565	0.800	172
33620.G017	9/16	1.7	,594	,460	,565	0.800	116
33620.G025	9/16	2.5	,594	,460	,565	0.800	140
33620.G040	9/16	4.0	,594	,460	,565	0.800	189
33620.G050	9/16	5.0	,594	,460	,565	0.800	-
33620.G060	9/16	6.0	,594	,460	,565	0.800	249
33620.G075	9/16	7.5	,594	,460	,565	0.800	298

Order No.	Ø f max.	g max.	h min.	k max.	Shearing resistance, double	Location hole dia. max.	MS Part No.
					lb min.		
33620.A005	1.80	1.27	0.76	0.34	5.150	0.1940	MS17986C305
33620.A008	1.80	1.27	0.76	0.34	5.150	0.1940	MS17986C308
33620.A010	1.80	1.27	0.76	0.34	5.150	0.1940	MS17986C310
33620.A013	1.80	1.27	0.76	0.34	5.150	0.1940	MS17986C313
33620.A014	1.80	1.27	0.76	0.34	5.150	0.1940	MS17986C314
33620.A017	1.80	1.27	0.76	0.34	5.150	0.1940	MS17986C317
33620.B012	1.80	1.27	0.76	0.34	9.200	0.2540	MS17986C412
33620.B015	1.80	1.27	0.76	0.34	9.200	0.2540	MS17986C415
33620.B017	1.80	1.27	0.76	0.34	9.200	0.2540	MS17986C417
33620.B016	1.80	1.27	0.76	0.34	9.200	0.2540	MS17986C416
33620.B021	1.80	1.27	0.76	0.34	9.200	0.2540	MS17986C421
33620.C004	1.80	1.27	0.76	0.34	14400	0.3165	MS17986C504
33620.C006	1.80	1.27	0.76	0.34	14400	0.3165	MS17986C506
33620.C010	1.80	1.27	0.76	0.34	14400	0.3165	MS17986C510
33620.C013	1.80	1.27	0.76	0.34	14400	0.3165	MS17986C513
33620.C016	1.80	1.27	0.76	0.34	14400	0.3165	MS17986C516
33620.C018	1.80	1.27	0.76	0.34	14400	0.3165	MS17986C518
33620.C020	1.80	1.27	0.76	0.34	14400	0.3165	MS17986C520
33620.C023	1.80	1.27	0.76	0.34	14400	0.3165	MS17986C523
33620.C029	1.80	1.27	0.76	0.34	14400	0.3165	MS17986C529
33620.C030	1.80	1.27	0.76	0.34	14400	0.3165	MS17986C530
33620.C033	1.80	1.27	0.76	0.34	14400	0.3165	MS17986C533
33620.C036	1.80	1.27	0.76	0.34	14400	0.3165	MS17986C536
33620.C040	1.80	1.27	0.76	0.34	14400	0.3165	MS17986C540
33620.D010	2.03	1.45	0.85	0.39	20700	0.3790	MS17986C610
33620.D015	2.03	1.45	0.85	0.39	20700	0.3790	MS17986C615
33620.D020	2.03	1.45	0.85	0.39	20700	0.3790	MS17986C620
33620.D024	2.03	1.45	0.85	0.39	20700	0.3790	MS17986C624
33620.D026	2.03	1.45	0.85	0.39	20700	0.3790	MS17986C626
33620.D030	2.03	1.45	0.85	0.39	20700	0.3790	MS17986C630
33620.D060	2.03	1.45	0.85	0.39	20700	0.3790	MS17986C660
33620.E012	2.03	1.47	0.85	0.39	28500	0.4425	MS17986C712
33620.E035	2.03	1.47	0.85	0.39	28500	0.4425	MS17986C735
33620.E040	2.03	1.47	0.85	0.39	28500	0.4425	MS17986C740
33620.E055	2.03	1.47	0.85	0.39	28500	0.4425	MS17986C755
33620.F010	2.36	1.60	0.85	0.50	36900	0.5050	MS17986C810
33620.F015	2.36	1.60	0.85	0.50	36900	0.5050	MS17986C815
33620.F019	2.36	1.60	0.85	0.50	36900	0.5050	MS17986C819



Aviation Pip-Pin, Standard LA Handle

single acting, quick release pins - according to

Ball Lock Pins & Quick Release



Order No.	Ø f max.	g max.	h min.	k max.	Shearing resistance, double lb min.	Location hole dia. max.	MS Part No.
33620.F034	2.36	1.60	0.85	0.50	36900	0.5050	MS17986C834
33620.F042	2.36	1.60	0.85	0.50	36900	0.5050	MS17986C842
33620.F045	2.36	1.60	0.85	0.50	36900	0.5050	MS17986C845
33620.G017	2.36	1.60	0.85	0.50	46700	0.5675	MS17986C917
33620.G025	2.36	1.60	0.85	0.50	46700	0.5675	MS17986C925
33620.G040	2.36	1.60	0.85	0.50	46700	0.5675	MS17986C940
33620.G050	2.36	1.60	0.85	0.50	46700	0.5675	MS17986C950
33620.G060	2.36	1.60	0.85	0.50	46700	0.5675	MS17986C960
33620.G075	2.36	1.60	0.85	0.50	46700	0.5675	MS17986C975

BALL LOCK PINS & QUICK RELEASE PINS



33630

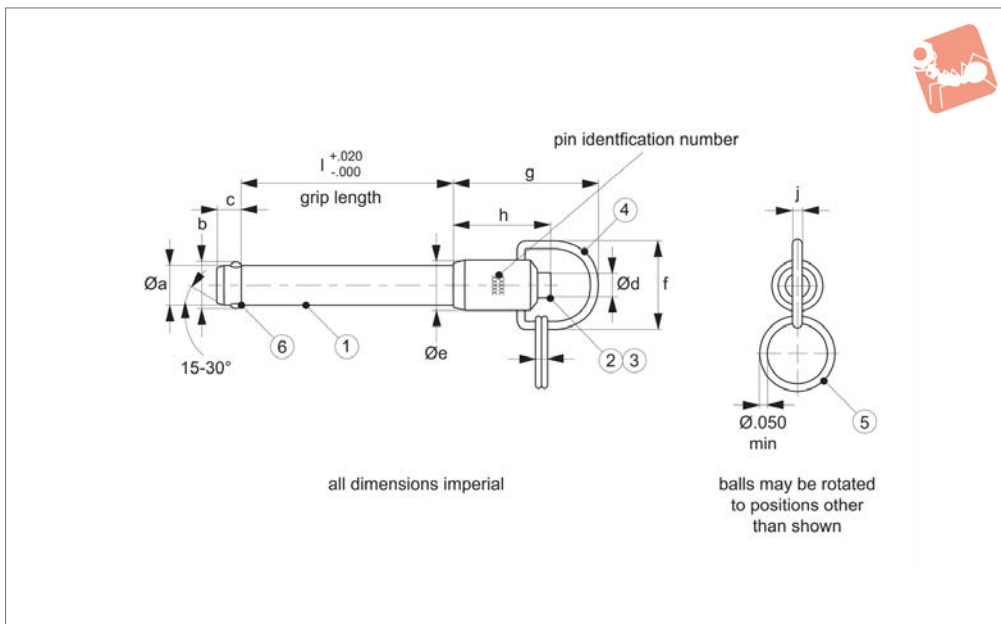

Material

Shank (part 1) & spindle (part 2):

CRES 17-4PH (AMS 5643), heat treated per MIL-H-6875, condition H900, min. 40 HRC, passivated per AMS2700.

Spring (part 3, not shown):

CRES 302 (ASTM-A-313), heat treated per MIL-H-6875, passivated per AMS2700.

Handle (part 4):

CRES 302 (ASTM-A-313), passivated per AMS2700.

Attaching ring (part 5):

CRES 302 (ASTM-A-313), passivated per AMS2700.

Ball (locking element, part 6):

CRES CL440C (AMS5630), heat treated per MIL-H-6875, passivated per AMS2700.

Technical Notes

Wixroyd Aviation Pip-pins manufactured to Aviation Norm NASM 17987 (former norm: MS 17987) and tested to NAS 1332.

Manufacture certified & assessed to EN9100D by EASE (European Aerospace Supplier Evaluation).

Temp. range -22°F to 302°F

Pressing = unlocking.

Releasing = locking.

Pip-pins are used for frequently repeated operations such as quick fastening, locking, adjusting, changing and securing. All dimensions shown are imperial.

Tips

We can manufacture specials (both metric & imperial) to your drawing, and are certified to produce to NASM standards.

Wixroyd Aviation Pip-Pins can be produced within the following dimensions:

+ diameter: from 3/16" to 1"

+ grip length: from 0.3" to 9.9"

Quick production time on small batches.

Order No.	Dia. Ø nom.	Grip l	b	c	Ø d max.	Ø e max.	Weight g
33630.A008	3/16	0.8	,594	,460	,565	0.53	24
33630.A009	3/16	0.9	,594	,460	,565	0.53	24
33630.A010	3/16	1.0	,594	,460	,565	0.53	24
33630.A011	3/16	1.1	,594	,460	,565	0.53	25
33630.A012	3/16	1.2	,594	,460	,565	0.53	25
33630.A015	3/16	1.5	,594	,460	,565	0.53	26
33630.A016	3/16	1.6	,594	,460	,565	0.53	26
33630.A017	3/16	1.7	,594	,460	,565	0.53	27
33630.A025	3/16	2.5	,594	,460	,565	0.53	30
33630.A031	3/16	3.1	,594	,460	,565	0.53	33
33630.A043	5/16	4.3	,594	,460	,565	0.53	-
33630.B004	1/4	0.4	,594	,460	,565	0.53	24
33630.B005	1/4	0.5	,594	,460	,565	0.53	24
33630.B006	1/4	0.6	,594	,460	,565	0.53	25
33630.B007	1/4	0.7	,594	,460	,565	0.53	26
33630.B008	1/4	0.8	,594	,460	,565	0.53	27
33630.B009	1/4	0.9	,594	,460	,565	0.53	27
33630.B010	1/4	1.0	,594	,460	,565	0.53	27
33630.B011	1/4	1.1	,594	,460	,565	0.53	28
33630.B012	1/4	1.2	,594	,460	,565	0.53	29
33630.B014	1/4	1.4	,594	,460	,565	0.53	30



Aviation Pip-Pin, Standard R Handle

single acting, quick release pins - according to

Ball Lock Pins & Quick Release



Order No.	Dia. Ø nom.	Grip l	b	c	Ø d max.	Ø e max.	Weight g
33630.B015	1/4	1.5	,594	,460	,565	0.53	31
33630.B017	1/4	1.7	,594	,460	,565	0.53	32
33630.B018	1/4	1.8	,594	,460	,565	0.53	32
33630.B019	1/4	1.9	,594	,460	,565	0.53	33
33630.B020	1/4	2.0	,594	,460	,565	0.53	34
33630.B021	1/4	2.1	,594	,460	,565	0.53	34
33630.B022	1/4	2.2	,594	,460	,565	0.53	36
33630.B025	1/4	2.5	,594	,460	,565	0.53	37
33630.B029	1/4	2.9	,594	,460	,565	0.53	40
33630.B030	1/4	3.0	,594	,460	,565	0.53	39
33630.B040	1/4	4.0	,594	,460	,565	0.53	47
33630.B047	1/4	4.7	,594	,460	,565	0.53	50
33630.C006	5/16	0.6	,594	,460	,565	0.59	30
33630.C007	5/16	0.7	,594	,460	,565	0.59	31
33630.C008	5/16	0.8	,594	,460	,565	0.59	33
33630.C009	5/16	0.9	,594	,460	,565	0.59	34
33630.C011	5/16	1.1	,594	,460	,565	0.59	35
33630.C012	5/16	1.2	,594	,460	,565	0.59	36
33630.C013	5/16	1.3	,594	,460	,565	0.59	38
33630.C015	5/16	1.5	,594	,460	,565	0.59	39
33630.C016	5/16	1.6	,594	,460	,565	0.59	39
33630.C018	5/16	1.8	,594	,460	,565	0.59	42
33630.C019	5/16	1.9	,594	,460	,565	0.59	43
33630.C020	5/16	2.0	,594	,460	,565	0.59	43
33630.C023	5/16	2.3	,594	,460	,565	0.59	46
33630.C026	5/16	2.6	,594	,460	,565	0.59	48
33630.C033	5/16	3.3	,594	,460	,565	0.59	56
33630.C035	5/16	3.5	,594	,460	,565	0.59	59
33630.C060	5/16	6.0	,594	,460	,565	0.59	85
33630.C067	5/16	6.7	,594	,460	,565	0.59	92
33630.D008	3/8	0.8	,594	,460	,565	0.65	49
33630.D009	3/8	0.9	,594	,460	,565	0.65	50
33630.D010	3/8	1.0	,594	,460	,565	0.65	52
33630.D011	3/8	1.1	,594	,460	,565	0.65	53
33630.D012	3/8	1.2	,594	,460	,565	0.65	54
33630.D013	3/8	1.3	,594	,460	,565	0.65	55
33630.D014	3/8	1.4	,594	,460	,565	0.65	55
33630.D015	3/8	1.5	,594	,460	,565	0.65	58
33630.D016	3/8	1.6	,594	,460	,565	0.65	61
33630.D018	3/8	1.8	,594	,460	,565	0.65	62
33630.D026	3/8	2.6	,594	,460	,565	0.65	73
33630.D030	3/8	3.0	,594	,460	,565	0.65	80
33630.D031	3/8	3.1	,594	,460	,565	0.65	82
33630.D043	3/8	4.3	,594	,460	,565	0.65	97
33630.E008	7/16	0.8	,594	,460	,565	0.71	56
33630.E012	7/16	1.2	,594	,460	,565	0.71	65
33630.E014	7/16	1.4	,594	,460	,565	0.71	68
33630.E015	7/16	1.5	,594	,460	,565	0.71	-
33630.E019	7/16	1.9	,594	,460	,565	0.71	77
33630.E020	7/16	2.0	,594	,460	,565	0.71	81
33630.E022	7/16	2.2	,594	,460	,565	0.71	81
33630.E024	7/16	2.4	,594	,460	,565	0.71	88
33630.E026	7/16	2.6	,594	,460	,565	0.71	88
33630.F011	1/2	1.1	,594	,460	,565	0.80	88
33630.F012	1/2	1.2	,594	,460	,565	0.80	91
33630.F013	1/2	1.3	,594	,460	,565	0.80	93
33630.F014	1/2	1.4	,594	,460	,565	0.80	96
33630.F015	1/2	1.5	,594	,460	,565	0.80	98
33630.F020	1/2	2.0	,594	,460	,565	0.80	109
33630.F023	1/2	2.3	,594	,460	,565	0.80	117
33630.F033	1/2	3.3	,594	,460	,565	0.80	141
33630.F039	1/2	3.9	,594	,460	,565	0.80	160
33630.F045	1/2	4.5	,594	,460	,565	0.80	160
33630.F050	1/2	5.0	,594	,460	,565	0.80	187
33630.F053	1/2	5.3	,594	,460	,565	0.80	186
33630.F065	1/2	6.5	,594	,460	,565	0.80	215
33630.F080	1/2	8.0	,594	,460	,565	0.80	260
33630.G013	9/16	1.3	,594	,460	,565	0.84	120



Order No.	Dia. Ø nom.	Grip l	b	c	Ø d max.	Ø e max.	Weight g
33630.G025	9/16	2.5	,594	,460	,565	0.84	150
33630.G030	9/16	3.0	,594	,460	,565	0.84	166
33630.G037	9/16	3.7	,594	,460	,565	0.84	183
33630.G055	9/16	5.5	,594	,460	,565	0.84	245

Order No.	Ø f max.	g max.	h min.	Shearing resistance, double lb min.	Location hole dia. max.	MS Part No.
33630.A008	1.45	0.73	0.08	5.150	0.1940	MS17987C308
33630.A009	1.45	0.73	0.08	5.150	0.1940	MS17987C309
33630.A010	1.45	0.73	0.08	5.150	0.1940	MS17987C310
33630.A011	1.45	0.73	0.08	5.150	0.1940	MS17987C311
33630.A012	1.45	0.73	0.08	5.150	0.1940	MS17987C312
33630.A015	1.45	0.73	0.08	5.150	0.1940	MS17987C315
33630.A016	1.45	0.73	0.08	5.150	0.1940	MS17987C316
33630.A017	1.45	0.73	0.08	5.150	0.1940	MS17987C317
33630.A025	1.45	0.73	0.08	5.150	0.1940	MS17987C325
33630.A031	1.45	0.73	0.08	5.150	0.1940	MS17987C331
33630.A043	1.45	0.73	0.08	5.150	0.1940	MS17987C343
33630.B004	1.50	0.78	0.08	9.200	0.2540	MS17987C404
33630.B005	1.50	0.78	0.08	9.200	0.2540	MS17987C405
33630.B006	1.50	0.78	0.08	9.200	0.2540	MS17987C406
33630.B007	1.50	0.78	0.08	9.200	0.2540	MS17987C407
33630.B008	1.50	0.78	0.08	9.200	0.2540	MS17987C408
33630.B009	1.50	0.78	0.08	9.200	0.2540	MS17987C409
33630.B010	1.50	0.78	0.08	9.200	0.2540	MS17987C410
33630.B011	1.50	0.78	0.08	9.200	0.2540	MS17987C411
33630.B012	1.50	0.78	0.08	9.200	0.2540	MS17987C412
33630.B014	1.50	0.78	0.08	9.200	0.2540	MS17987C414
33630.B015	1.50	0.78	0.08	9.200	0.2540	MS17987C415
33630.B017	1.50	0.78	0.08	9.200	0.2540	MS17987C417
33630.B018	1.50	0.78	0.08	9.200	0.2540	MS17987C418
33630.B019	1.50	0.78	0.08	9.200	0.2540	MS17987C419
33630.B020	1.50	0.78	0.08	9.200	0.2540	MS17987C420
33630.B021	1.50	0.78	0.08	9.200	0.2540	MS17987C421
33630.B022	1.50	0.78	0.08	9.200	0.2540	MS17987C422
33630.B025	1.50	0.78	0.08	9.200	0.2540	MS17987C425
33630.B029	1.50	0.78	0.08	9.200	0.2540	MS17987C429
33630.B030	1.50	0.78	0.08	9.200	0.2540	MS17987C430
33630.B040	1.50	0.78	0.08	9.200	0.2540	MS17987C440
33630.B047	1.50	0.78	0.08	9.200	0.2540	MS17987C447
33630.C006	1.65	0.83	0.08	14400	0.3165	MS17987C506
33630.C007	1.65	0.83	0.08	14400	0.3165	MS17987C507
33630.C008	1.65	0.83	0.08	14400	0.3165	MS17987C508
33630.C009	1.65	0.83	0.08	14400	0.3165	MS17987C509
33630.C011	1.65	0.83	0.08	14400	0.3165	MS17987C511
33630.C012	1.65	0.83	0.08	14400	0.3165	MS17987C512
33630.C013	1.65	0.83	0.08	14400	0.3165	MS17987C513
33630.C015	1.65	0.83	0.08	14400	0.3165	MS17987C515
33630.C016	1.65	0.83	0.08	14400	0.3165	MS17987C516
33630.C018	1.65	0.83	0.08	14400	0.3165	MS17987C518
33630.C019	1.65	0.83	0.08	14400	0.3165	MS17987C519
33630.C020	1.65	0.83	0.08	14400	0.3165	MS17987C520
33630.C023	1.65	0.83	0.08	14400	0.3165	MS17987C523
33630.C026	1.65	0.83	0.08	14400	0.3165	MS17987C526
33630.C033	1.65	0.83	0.08	14400	0.3165	MS17987C533
33630.C035	1.65	0.83	0.08	14400	0.3165	MS17987C535
33630.C060	1.65	0.83	0.08	14400	0.3165	MS17987C560
33630.C067	1.65	0.83	0.08	14400	0.3165	MS17987C567
33630.D008	1.65	0.94	0.08	20700	0.3790	MS17987C608
33630.D009	1.65	0.94	0.08	20700	0.3790	MS17987C609
33630.D010	1.65	0.94	0.08	20700	0.3790	MS17987C610
33630.D011	1.65	0.94	0.08	20700	0.3790	MS17987C611
33630.D012	1.65	0.94	0.08	20700	0.3790	MS17987C612
33630.D013	1.65	0.94	0.08	20700	0.3790	MS17987C613
33630.D014	1.65	0.94	0.08	20700	0.3790	MS17987C614
33630.D015	1.65	0.94	0.08	20700	0.3790	MS17987C615
33630.D016	1.65	0.94	0.08	20700	0.3790	MS17987C616



Aviation Pip-Pin, Standard R Handle

single acting, quick release pins - according to

Ball Lock Pins & Quick Release



Order No.	Ø f max.	g max.	h min.	Shearing resistance, double lb min.	Location hole dia. max.	MS Part No.
33630.D018	1.65	0.94	0.08	20700	0.3790	MS17987C618
33630.D026	1.65	0.94	0.08	20700	0.3790	MS17987C626
33630.D030	1.65	0.94	0.08	20700	0.3790	MS17987C630
33630.D031	1.65	0.94	0.08	20700	0.3790	MS17987C631
33630.D043	1.65	0.94	0.08	20700	0.3790	MS17987C643
33630.E008	1.85	0.98	0.08	28500	0.4425	MS17987C708
33630.E012	1.85	0.98	0.08	28500	0.4425	MS17987C712
33630.E014	1.85	0.98	0.08	28500	0.4425	MS17987C714
33630.E015	1.85	0.98	0.08	28500	0.4425	MS17987C715
33630.E019	1.85	0.98	0.08	28500	0.4425	MS17987C719
33630.E020	1.85	0.98	0.08	28500	0.4425	MS17987C720
33630.E022	1.85	0.98	0.08	28500	0.4425	MS17987C722
33630.E024	1.85	0.98	0.08	28500	0.4425	MS17987C724
33630.E026	1.85	0.98	0.08	28500	0.4425	MS17987C726
33630.F011	1.85	1.14	0.08	36900	0.5050	MS17987C811
33630.F012	1.85	1.14	0.08	36900	0.5050	MS17987C812
33630.F013	1.85	1.14	0.08	36900	0.5050	MS17987C813
33630.F014	1.85	1.14	0.08	36900	0.5050	MS17987C814
33630.F015	1.85	1.14	0.08	36900	0.5050	MS17987C815
33630.F020	1.85	1.14	0.08	36900	0.5050	MS17987C820
33630.F023	1.85	1.14	0.08	36900	0.5050	MS17987C823
33630.F033	1.85	1.14	0.08	36900	0.5050	MS17987C833
33630.F039	1.85	1.14	0.08	33900	0.5050	MS17987C839
33630.F045	1.85	1.14	0.08	36900	0.5050	MS17987C845
33630.F050	1.85	1.14	0.08	36900	0.5050	MS17987C850
33630.F053	1.85	1.14	0.08	36900	0.5050	MS17987C853
33630.F065	1.85	1.14	0.08	36900	0.5050	MS17987C865
33630.F080	1.85	1.14	0.08	36900	0.5050	MS17987C880
33630.G013	2.03	1.14	0.08	46700	0.5675	MS17987C913
33630.G025	2.03	1.14	0.08	46700	0.5675	MS17987C925
33630.G030	2.03	1.14	0.08	46700	0.5675	MS17987C930
33630.G037	2.03	1.14	0.08	46700	0.5675	MS17987C937
33630.G055	2.03	1.14	0.08	46700	0.5675	MS17987C955

BALL LOCK PINS & QUICK RELEASE PINS



Wixroyd Flight Pin Range - Certified to Aviation Standards

With many years experience producing an extensive range of standard Pip-pins (also know as quick release pins or ball lock pins) we are now able to offer of Aviation Standard approved Pip-pins, manufactured according to NASM norms (formerly MS norms) and tested to NAS 1332 standards.

Expanding Range



33600 - Single acting Pip-pin, standard B handle

33610 - Single acting Pip-pin, standard TA handle

33620 - Single acting Pip-pin, standard LA handle

33630 - Single acting Pip-pin, standard R handle

Wide Range of Aviation Applications

- Interior panel attachment
- Baby bassinet pin
- Curtain track attachment
- Curtain track support pins
- TV monitor attachment
- Folding table assembly (e.g. First Class Cabins)

Aviation Approved

The Wixroyd Aviation Pip-pin range is produced according to NASM norms, and tested to NAS standards. Our manufacturing processes have been assessed and certified by EASE (European Aerospace Supplier Evaluation) to EN9100D.

All our Aviation Pip-pins are individually marked to enable identification of their production lot number.

In-Stock and Available?

Yes! The product sizes shown on the following pages, with a cross reference to the NASM part code for ease of identification, are all available from stock for delivery within 5 days.

Special Designs

We have extensive knowledge and experience in designing, producing and assembling bespoke design pip-pins and ball lock pins in both imperial and metric sizes. We produce under a fully certified manufacturing process, both to our own high standard or to meet Aviation standards. Please contact our technical team to discuss your requirements (tel. 0845 26 66 577) or email a drawing to info@wixroyd.com

For our full range visit:
wixroyd.com



Wixroyd Flight Pin Range - Certified to Aviation Standards

Your normal experience may be that imperial Aviation Standard Pip-pins are hard to obtain; price prohibitive, and delivery times far too long. The range of Wixroyd Aviation Pip-pins, in a variety of imperial dimensions, has been designed to solve these problems - we hold a wide, and ever increasing range of sizes ex-stock for immediate delivery - no more 6-8 week lead time!

With many years experience producing an extensive range of standard Pip-pins (also know as quick release pins or ball lock pins) we are now able to offer of Aviation Standard approved Pip-pins, manufactured according to NASM norms (formerly MS norms) and tested to NAS 1332 standards.

- Interior panel attachment
- Baby bassinet pin
- Curtain track attachment
- Curtain track support pins
- TV monitor attachment
- Folding table assembly (e.g. First Class Cabins)

Wide Range of Aviation Applications

Yes! The product sizes shown on the following pages, with a cross reference to the NASM part code for ease of identification, are all available from stock for delivery within 5 days.

In-stock and Available?

Our Aviation Pip-pins are manufactured to NASM norms, and we follow the material specification of these norms, which means you can feel safe in purchasing a part which is to specification - both in materials and strength.

Materials



The new Wixroyd Aviation Pip-pin range is produced according to NASM norms, and tested to NAS standards. Our manufacturing processes have been assessed and certified by EASE (European Aerospace Supplier Evaluation) to EN9100D.

Aviation Approved

All our Aviation Pip-pins are individually marked to enable identification of their production lot number. Marking allows identification of:

Identifying Production Batches

- NASM Standard Number
- Material Grade
- Pin/shank diameter
- Grip length
- Company identification
- Production lot number.

We have extensive knowledge and experience in designing, producing and assembling bespoke design pip-pins and ball lock pins in both imperial and metric sizes. We produce under a fully certified manufacturing process, both to our own high standard or to meet Aviation standards.

Special Designs

We can customise to meet your needs:

- Changes in grip/handle type
- Material variations
- Changes of functional dimensions; pin diameter, pin grip length

Please contact our technical team to discuss your requirements (tel. 0845 26 66 577) or email a drawing to info@wixroyd.com

Expanding Range



Single acting Pip-pin, standard B handle

Single acting Pip-pin, standard TA handle

Single acting Pip-pin, standard LA handle

Single acting Pip-pin, standard R handle



33140

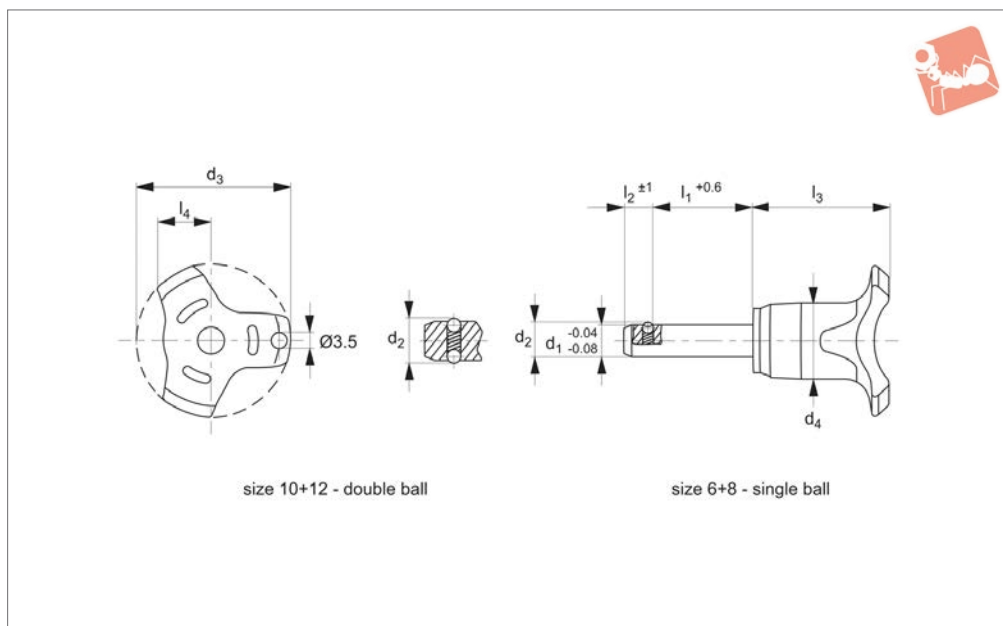

Material

Pin: stainless steel 1,4305 (AISI 303).
Handle: thermoplastic PA 6, grey.
Spring: stainless steel.

Technical Notes

Balls are simply spring loaded and do not

lock out. Resulting in pins being easier to pull out.

Temperature range: -30°C to +80°C.
For a quick fastening, locking, adjusting, changing and securing. Quickly and easily unlockable for frequently repeated

connections.

Tips

For lanyards & retaining cables see part no. 33250.

Order No.	d ₁	l ₁	d ₂	d ₃	d ₄	l ₂	l ₃	l ₄	Location hole tol. H11	Shearing resistance, double kN min.	Tensile force non lubricated N max.	Weight g
33140.W0062	6	10	6.5	38	17.3	5.0	27.0	10.8	6	22	8	14
33140.W0064	6	15	6.5	38	17.3	5.0	27.0	10.8	6	22	8	16
33140.W0066	6	20	6.5	38	17.3	5.0	27.0	10.8	6	22	8	16
33140.W0068	6	25	6.5	38	17.3	5.0	27.0	10.8	6	22	8	17
33140.W0070	6	30	6.5	38	17.3	5.0	27.0	10.8	6	22	8	18
33140.W0075	6	50	6.5	38	17.3	5.0	27.0	10.8	6	22	8	23
33140.W0084	8	15	8.7	38	17.3	6.3	28.6	10.8	8	40	15	21
33140.W0086	8	20	8.7	38	17.3	6.3	28.6	10.8	8	40	15	22
33140.W0088	8	25	8.7	38	17.3	6.3	28.6	10.8	8	40	15	25
33140.W0090	8	30	8.7	38	17.3	6.3	28.6	10.8	8	40	15	27
33140.W0095	8	50	8.7	38	17.3	6.3	28.6	10.8	8	40	15	33
33140.W0104	10	15	12.0	38	17.3	8.7	28.6	10.8	10	62	30	32
33140.W0106	10	20	12.0	38	17.3	8.7	28.6	10.8	10	62	30	35
33140.W0108	10	25	12.0	38	17.3	8.7	28.6	10.8	10	62	30	38
33140.W0110	10	30	12.0	38	17.3	8.7	28.6	10.8	10	62	30	39
33140.W0115	10	50	12.0	38	17.3	8.7	28.6	10.8	10	62	30	53
33140.W0122	12	20	14.5	38	17.3	9.5	28.6	10.8	12	90	32	43
33140.W0124	12	30	14.5	38	17.3	9.5	28.6	10.8	12	90	32	52
33140.W0126	12	40	14.5	38	17.3	9.5	28.6	10.8	12	90	32	61
33140.W0128	12	50	14.5	38	17.3	9.5	28.6	10.8	12	90	32	68



Socket Pins
non-locking

Ball Lock Pins &
Quick Release



BALL LOCK PINS & QUICK RELEASE PINS



33331

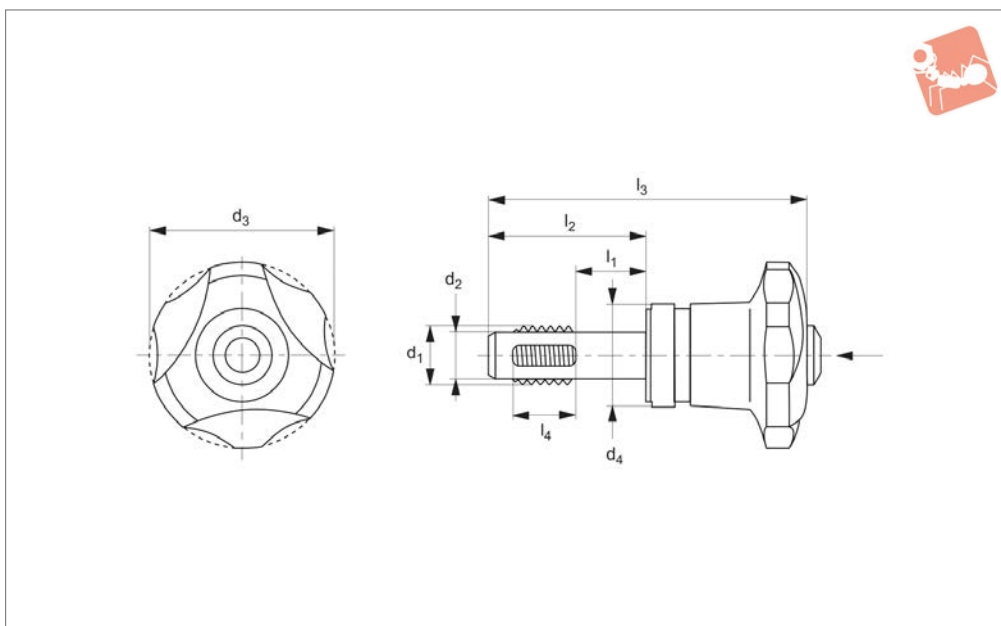

Material

Pin: Free cutting steel, manganese phosphated or stainless steel 1.4305 (AISI 303).

Handle: Thermoplastic PA 6, black similar to RAL 9005

Press button: Aluminium, orange, anodised.

Threaded element: stainless steel 1.4542

(AISI 630), precipitation-hardened.

Spring: stainless steel.

Technical Notes

Pressing = unlocking.

Releasing = locking.

To suit metric course threads. The threaded lock pin can be quickly inserted into a threaded hole, and further tightened

up to indicated max. torque reducing both assembly and disassembly times.

Tips

For suitable lanyards see part no. 33268. Lanyards can be used to prevent accidental loss of pin from application.

Order No.	Type	d ₁	l ₁	d ₂ -0.07	d ₃	d ₄	Weight g
33331.W0102	Steel	M 8	10	6.62	40	21.6	40
33331.W0104	Steel	M 8	20	6.62	40	21.6	42
33331.W0106	Steel	M 8	30	6.62	40	21.6	45
33331.W0202	Steel	M10	10	8.35	40	21.6	44
33331.W0204	Steel	M10	20	8.35	40	21.6	48
33331.W0206	Steel	M10	30	8.35	40	21.6	52
33331.W0303	Steel	M12	15	10.07	40	21.6	53
33331.W0306	Steel	M12	30	10.07	40	21.6	62
33331.W0310	Steel	M12	50	10.07	40	21.6	74
33331.W0503	Steel	M16	15	13.80	40	21.6	70
33331.W0506	Steel	M16	30	13.80	40	21.6	87
33331.W0510	Steel	M16	50	13.80	40	21.6	109
33331.W1102	Stainless Steel	M 8	10	6.62	40	21.6	40
33331.W1104	Stainless Steel	M 8	20	6.62	40	21.6	42
33331.W1106	Stainless Steel	M 8	30	6.62	40	21.6	45
33331.W1202	Stainless Steel	M10	10	8.35	40	21.6	44
33331.W1204	Stainless Steel	M10	20	8.35	40	21.6	48
33331.W1206	Stainless Steel	M10	30	8.35	40	21.6	52
33331.W1303	Stainless Steel	M12	15	10.07	40	21.6	53
33331.W1306	Stainless Steel	M12	30	10.07	40	21.6	62
33331.W1310	Stainless Steel	M12	50	10.07	40	21.6	74
33331.W1503	Stainless Steel	M16	15	13.80	40	21.6	70
33331.W1506	Stainless Steel	M16	30	13.80	40	21.6	87
33331.W1510	Stainless Steel	M16	50	13.80	40	21.6	109



Threaded Lock Pins self-locking

Ball Lock Pins & Quick Release



Order No.	l ₂	l ₃	l ₄	Locating thread	Temp. resistance °C min.	Temp. resistance °C max.	Torque to Nm max.	Shearing resistance two-shear kN min.
33331.W0102	23.8	58.4	8	M 8	-30	80	5	12.7
33331.W0104	33.8	68.4	8	M 8	-30	80	5	12.7
33331.W0106	43.8	78.4	8	M 8	-30	80	5	12.7
33331.W0202	26.0	60.6	10	M10	-30	80	5	20.6
33331.W0204	36.0	70.6	10	M10	-30	80	5	20.6
33331.W0206	46.0	80.6	10	M10	-30	80	5	20.6
33331.W0303	34.0	68.6	12	M12	-30	80	5	30.4
33331.W0306	49.0	83.6	12	M12	-30	80	5	30.4
33331.W0310	69.0	103.6	12	M12	-30	80	5	30.4
33331.W0503	34.0	68.6	12	M16	-30	80	5	62.9
33331.W0506	49.0	83.6	12	M16	-30	80	5	62.9
33331.W0510	69.0	103.6	12	M16	-30	80	5	62.9
33331.W1102	23.8	58.4	8	M 8	-30	80	5	16.7
33331.W1104	33.8	68.4	8	M 8	-30	80	5	16.7
33331.W1106	43.8	78.4	8	M 8	-30	80	5	16.7
33331.W1202	26.0	60.6	10	M10	-30	80	5	27.1
33331.W1204	36.0	70.6	10	M10	-30	80	5	27.1
33331.W1206	46.0	80.6	10	M10	-30	80	5	27.1
33331.W1303	34.0	68.6	12	M12	-30	80	5	40.0
33331.W1306	49.0	83.6	12	M12	-30	80	5	40.0
33331.W1310	69.0	103.6	12	M12	-30	80	5	40.0
33331.W1503	34.0	68.6	12	M16	-30	80	5	82.7
33331.W1506	49.0	83.6	12	M16	-30	80	5	82.7
33331.W1510	69.0	103.6	12	M16	-30	80	5	82.7

BALL LOCK PINS & QUICK RELEASE PINS

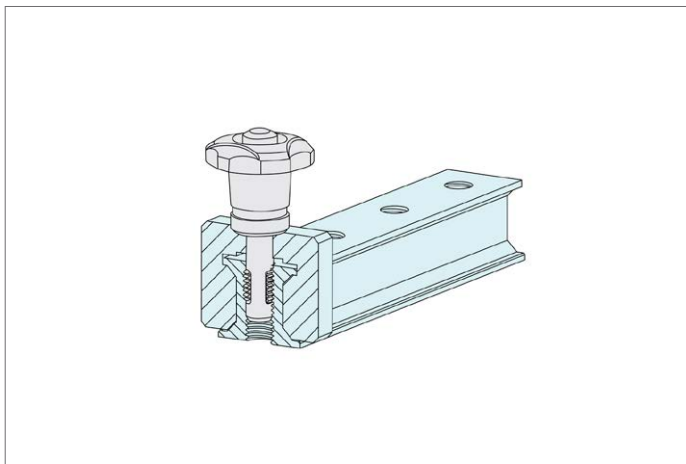



33010.1

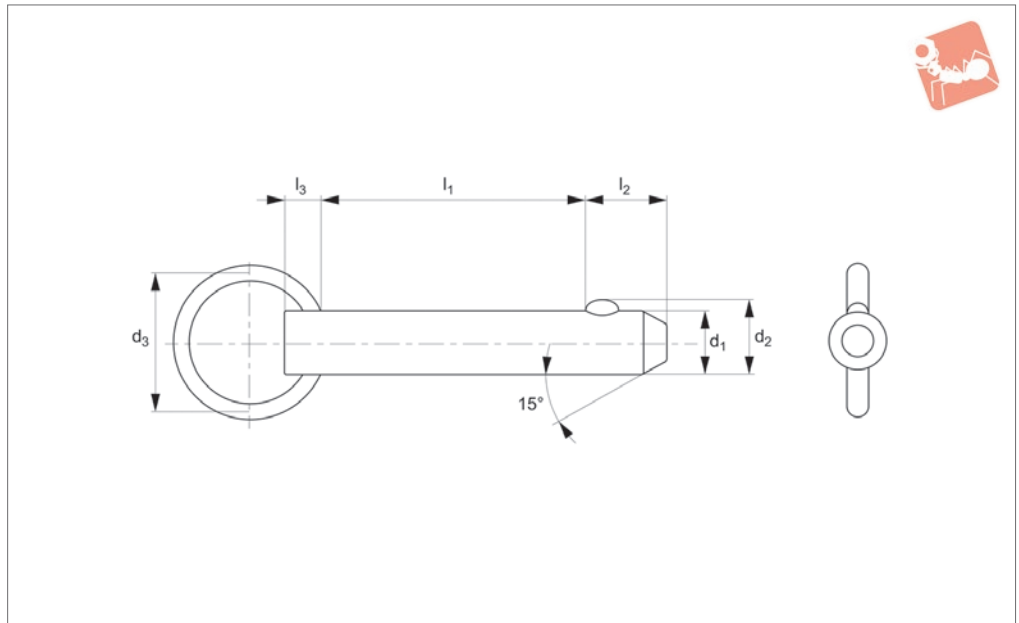

Material

Shaft: Carbon steel (C1144), zinc plated.
Ball & spring: Stainless steel AISI 316.

Technical Notes

Detent pins are very economical for use in commercial and military equipment. The solid body with direct spring loaded

ball ensures reliable operation. Can be used for locking telescopic tubing, securing bracket assemblies, as anchor clevis fittings, hinge pins and as replacement for cotter pins where frequent removal is necessary. Hole sizes - commercial drills provide clear-

ance for our standard pins. Inch dimensions in brackets ().

Tips

Also available in stainless steel see part no. PP1202.

Order No.	d_1 +0.00 -0.08	l_1 grip +1.50 -0.00	d_2	d_3	l_2	l_3	Pull out strength kg	Single shear strength kN min.
33010.W1183	4,76 (3/16")	7,62 (0,3")	5.18	25.4	5.08	4.74	1,9 - 2,3	10.8
33010.W1805	4,76 (3/16")	12,7 (0,5")	5.18	25.4	5.08	4.74	1,9 - 2,3	10.8
33010.W1810	4,76 (3/16")	25,4 (1")	5.18	25.4	5.08	4.74	1,9 - 2,3	10.8
33010.W1815	4,76 (3/16")	38,1 (1,5")	5.18	25.4	5.08	4.74	1,9 - 2,3	10.8
33010.W1820	4,76 (3/16")	50,8 (2")	5.18	25.4	5.08	4.74	1,9 - 2,3	10.8
33010.W1825	4,76 (3/16")	63,5 (2,5")	5.18	25.4	5.08	4.74	1,9 - 2,3	10.8
33010.W1830	4,76 (3/16")	76,2 (3")	5.18	25.4	5.08	4.74	1,9 - 2,3	10.8
33010.W1835	4,76 (3/16")	88,9 (3,5")	5.18	25.4	5.08	4.74	1,9 - 2,3	10.8
33010.W1840	4,76 (3/16")	101,6 (4")	5.18	25.4	5.08	4.74	1,9 - 2,3	10.8
33010.W2505	6,35 (1/4")	12,7 (0,5")	7.26	25.4	7.92	5.58	2,27 - 2,73	19.3
33010.W2510	6,35 (1/4")	25,4 (1")	7.26	25.4	7.92	5.58	2,27 - 2,73	19.3
33010.W2515	6,35 (1/4")	38,1 (1,5")	7.26	25.4	7.92	5.58	2,27 - 2,73	19.3
33010.W2520	6,35 (1/4")	50,8 (2")	7.26	25.4	7.92	5.58	2,27 - 2,73	19.3
33010.W2525	6,35 (1/4")	63,5 (2,5")	7.26	25.4	7.92	5.58	2,27 - 2,73	19.3
33010.W2530	6,35 (1/4")	76,2 (3")	7.26	25.4	7.92	5.58	2,27 - 2,73	19.3
33010.W2535	6,35 (1/4")	88,9 (3,5")	7.26	25.4	7.92	5.58	2,27 - 2,73	19.3
33010.W2540	6,35 (1/4")	101,6 (4")	7.26	25.4	7.92	5.58	2,27 - 2,73	19.3
33010.W3105	7,93 (5/16")	12,7 (0,5")	9.09	25.4	9.52	6.35	2,72 - 2,73	30.0
33010.W3110	7,93 (5/16")	25,4 (1")	9.09	25.4	9.52	6.35	2,72 - 2,73	30.0
33010.W3115	7,93 (5/16")	38,1 (1,5")	9.09	25.4	9.52	6.35	2,72 - 2,73	30.0
33010.W3120	7,93 (5/16")	50,8 (2")	9.09	25.4	9.52	6.35	2,72 - 2,73	30.0
33010.W3125	7,93 (5/16")	63,5 (2,5")	9.09	25.4	9.52	6.35	2,72 - 2,73	30.0
33010.W3130	7,93 (5/16")	76,2 (3")	9.09	25.4	9.52	6.35	2,72 - 2,73	30.0
33010.W3135	7,93 (5/16")	88,9 (3,5")	9.09	25.4	9.52	6.35	2,72 - 2,73	30.0
33010.W3140	7,93 (5/16")	101,6 (4")	9.09	25.4	9.52	6.35	2,72 - 2,73	30.0
33010.W3145	7,93 (5/16")	114,3 (4,5")	9.09	25.4	9.52	6.35	2,72 - 2,73	30.0
33010.W3150	7,93 (5/16")	127,0 (5")	9.09	25.4	9.52	6.35	2,72 - 2,73	30.0
33010.W3705	9,52 (3/8")	12,7 (0,5")	10.8	25.4	12.7	6.35	3,63 - 4,54	43.3
33010.W3710	9,52 (3/8")	25,4 (1")	10.8	25.4	12.7	6.35	3,63 - 4,54	43.3



Detent Pin Steel

Ball Lock Pins & Quick Release



Order No.	d ₁ +0.00 -0.08	l ₁ grip +1.50 -0.00	d ₂	d ₃	l ₂	l ₃	Pull out strength kg	Single shear strength kN min.
33010.W3715	9,52 (3/8")	38,1 (1,5")	10.8	25.4	12.7	6.35	3,63 - 4,54	43.3
33010.W3720	9,52 (3/8")	50,8 (2")	10.8	25.4	12.7	6.35	3,63 - 4,54	43.3
33010.W3725	9,52 (3/8")	63,5 (2,5")	10.8	25.4	12.7	6.35	3,63 - 4,54	43.3
33010.W3730	9,52 (3/8")	76,2 (3")	10.8	25.4	12.7	6.35	3,63 - 4,54	43.3
33010.W3735	9,52 (3/8")	88,9 (3,5")	10.8	25.4	12.7	6.35	3,63 - 4,54	43.3
33010.W3740	9,52 (3/8")	101,6 (4")	10.8	25.4	12.7	6.35	3,63 - 4,54	43.3
33010.W3745	9,52 (3/8")	114,3 (4,5")	10.8	25.4	12.7	6.35	3,63 - 4,54	43.3
33010.W3750	9,52 (3/8")	127,0 (5")	10.8	25.4	12.7	6.35	3,63 - 4,54	43.3
33010.W3755	9,52 (3/8")	139,7 (5,5")	10.8	25.4	12.7	6.35	3,63 - 4,54	43.3
33010.W3760	9,52 (3/8")	152,4 (6")	10.8	25.4	12.7	6.35	3,63 - 4,54	43.3
33010.W4305	11,1 (7/16")	12,7 (0,5")	12.5	25.4	14.2	6.35	4,09 - 5,45	58.9
33010.W4310	11,1 (7/16")	25,4 (1")	12.5	25.4	14.2	6.35	4,09 - 5,45	58.9
33010.W4315	11,1 (7/16")	38,1 (1,5")	12.5	25.4	14.2	6.35	4,09 - 5,45	58.9
33010.W4320	11,1 (7/16")	50,8 (2")	12.5	25.4	14.2	6.35	4,09 - 5,45	58.9
33010.W4325	11,1 (7/16")	63,5 (2,5")	12.5	25.4	14.2	6.35	4,09 - 5,45	58.9
33010.W4330	11,1 (7/16")	76,2 (3")	12.5	25.4	14.2	6.35	4,09 - 5,45	58.9
33010.W4335	11,1 (7/16")	89,0 (3,5")	12.5	25.4	14.2	6.35	4,09 - 5,45	58.9
33010.W4340	11,1 (7/16")	101,6 (4")	12.5	25.4	14.2	6.35	4,09 - 5,45	58.9
33010.W4345	11,1 (7/16")	114,3 (4,5")	12.5	25.4	14.2	6.35	4,09 - 5,45	58.9
33010.W4350	11,1 (7/16")	127,0 (5")	12.5	25.4	14.2	6.35	4,09 - 5,45	58.9
33010.W4355	11,1 (7/16")	139,7 (5,5")	12.5	25.4	14.2	6.35	4,09 - 5,45	58.9
33010.W4360	11,1 (7/16")	152,4 (6")	12.5	25.4	14.2	6.35	4,09 - 5,45	58.9
33010.W5005	12,7 (1/2")	12,7 (0,5")	14.4	31.7	15.8	7.92	4,54 - 5,45	77.0
33010.W5010	12,7 (1/2")	25,4 (1")	14.4	31.7	15.8	7.92	4,54 - 5,45	77.0
33010.W5015	12,7 (1/2")	38,1 (1,5")	14.4	31.7	15.8	7.92	4,54 - 5,45	77.0
33010.W5020	12,7 (1/2")	50,8 (2")	14.4	31.7	15.8	7.92	4,54 - 5,45	77.0
33010.W5025	12,7 (1/2")	63,5 (2,5")	14.4	31.7	15.8	7.92	4,54 - 5,45	77.0
33010.W5030	12,7 (1/2")	76,2 (3")	14.4	31.7	15.8	7.92	4,54 - 5,45	77.0
33010.W5035	12,7 (1/2")	88,9 (3,5")	14.4	31.7	15.8	7.92	4,54 - 5,45	77.0
33010.W5040	12,7 (1/2")	101,6 (4")	14.4	31.7	15.8	7.92	4,54 - 5,45	77.0
33010.W5045	12,7 (1/2")	114,3 (4,5")	14.4	31.7	15.8	7.92	4,54 - 5,45	77.0
33010.W5050	12,7 (1/2")	127,0 (5")	14.4	31.7	15.8	7.92	4,54 - 5,45	77.0
33010.W5055	12,7 (1/2")	139,7 (5,5")	14.4	31.7	15.8	7.92	4,54 - 5,45	77.0
33010.W5060	12,7 (1/2")	152,4 (6")	14.4	31.7	15.8	7.92	4,54 - 5,45	77.0
33010.W5065	12,7 (1/2")	165,1 (6,5")	14.4	31.7	15.8	7.92	4,54 - 5,45	77.0
33010.W5070	12,7 (1/2")	177,8 (7")	14.4	31.7	15.8	7.92	4,54 - 5,45	77.0

BALL LOCK PINS & QUICK RELEASE PINS



33010.2

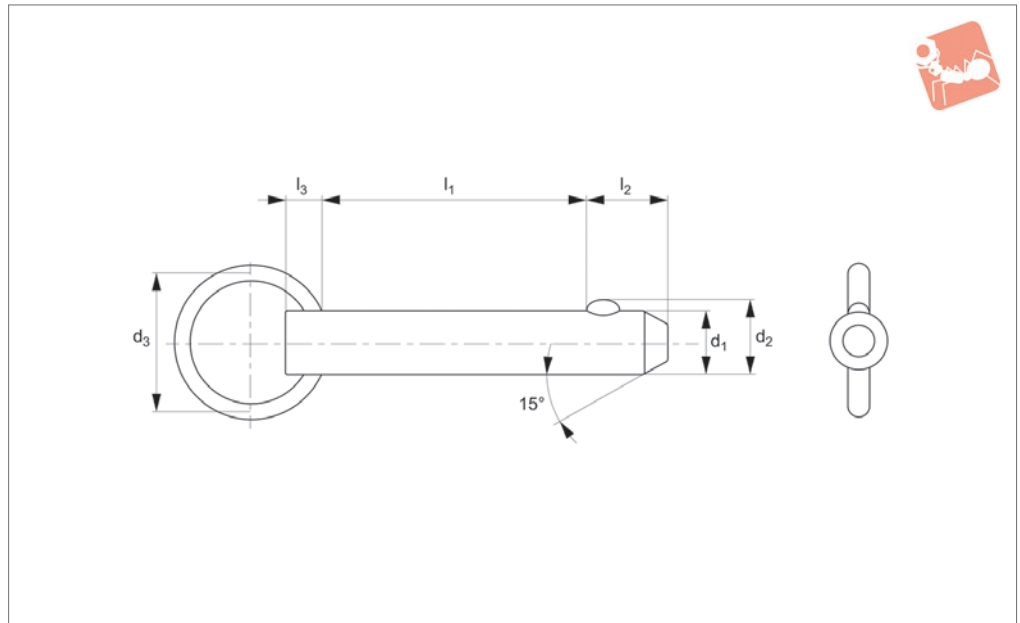

Material

Shaft: Carbon steel (C1144), zinc plated.
Ball & spring: Stainless steel AISI 316.

Technical Notes

Detent pins are very economical for use in commercial and military equipment. The solid body with direct spring loaded

ball ensures reliable operation. Can be used for locking telescopic tubing, securing bracket assemblies, as anchor clevis fittings, hinge pins and as replacement for cotter pins where frequent removal is necessary. Hole sizes - commercial drills provide clea-

rance for our standard pins. Inch dimensions in brackets ().

Tips

Also available in stainless steel see part no. PP1202.

Order No.	d_1 +0.00 -0.08	l_1 grip +1.50 -0.00	d_2	d_3	l_2	l_3	Pull out strength kg	Single shear strength kN min.
33010.W5610	14,2 (9/16")	25,4 (1")	16,3	31,7	17,4	7,92	5,45 - 6,81	97,6
33010.W5615	14,2 (9/16")	38,1 (1,5")	16,3	31,7	17,4	7,92	5,45 - 6,81	97,6
33010.W5620	14,2 (9/16")	50,8 (2")	16,3	31,7	17,4	7,92	5,45 - 6,81	97,6
33010.W5625	14,2 (9/16")	63,5 (2,5")	16,3	31,7	17,4	7,92	5,45 - 6,81	97,6
33010.W5630	14,2 (9/16")	76,2 (3")	16,3	31,7	17,4	7,92	5,45 - 6,81	97,6
33010.W5635	14,2 (9/16")	88,9 (3,5")	16,3	31,7	17,4	7,92	5,45 - 6,81	97,6
33010.W5640	14,2 (9/16")	101,6 (4")	16,3	31,7	17,4	7,92	5,45 - 6,81	97,6
33010.W5645	14,2 (9/16")	114,3 (4,5")	16,3	31,7	17,4	7,92	5,45 - 6,81	97,6
33010.W5650	14,2 (9/16")	127,0 (5")	16,3	31,7	17,4	7,92	5,45 - 6,81	97,6
33010.W5655	14,2 (9/16")	139,7 (5,5")	16,3	31,7	17,4	7,92	5,45 - 6,81	97,6
33010.W5660	14,2 (9/16")	152,4 (6")	16,3	31,7	17,4	7,92	5,45 - 6,81	97,6
33010.W5670	14,2 (9/16")	177,8 (7")	16,3	31,7	17,4	7,92	5,45 - 6,81	97,6
33010.W6210	15,8 (5/8")	25,4 (1")	18,0	31,7	19,0	9,52	3,36 - 7,26	121,6
33010.W6215	15,8 (5/8")	38,1 (1,5")	18,0	31,7	19,0	9,52	3,36 - 7,26	121,6
33010.W6220	15,8 (5/8")	50,8 (2")	18,0	31,7	19,0	9,52	3,36 - 7,26	121,6
33010.W6225	15,8 (5/8")	63,5 (2,5")	18,0	31,7	19,0	9,52	3,36 - 7,26	121,6
33010.W6230	15,8 (5/8")	76,2 (3")	18,0	31,7	19,0	9,52	3,36 - 7,26	121,6
33010.W6235	15,8 (5/8")	88,9 (3,5")	18,0	31,7	19,0	9,52	3,36 - 7,26	121,6
33010.W6240	15,8 (5/8")	101,6 (4")	18,0	31,7	19,0	9,52	3,36 - 7,26	121,6
33010.W6245	15,8 (5/8")	114,3 (4,5")	18,0	31,7	19,0	9,52	3,36 - 7,26	121,6
33010.W6250	15,8 (5/8")	127,0 (5")	18,0	31,7	19,0	9,52	3,36 - 7,26	121,6
33010.W6255	15,8 (5/8")	139,7 (5,5")	18,0	31,7	19,0	9,52	3,36 - 7,26	121,6
33010.W6260	15,8 (5/8")	152,4 (6")	18,0	31,7	19,0	9,52	3,36 - 7,26	121,6
33010.W6265	15,8 (5/8")	165,1 (6,5")	18,0	31,7	19,0	9,52	3,36 - 7,26	121,6
33010.W6270	15,8 (5/8")	177,8 (7")	18,0	31,7	19,0	9,52	3,36 - 7,26	121,6
33010.W6280	15,8 (5/8")	203,2 (8")	18,0	31,7	19,0	9,52	3,36 - 7,26	121,6
33010.W7510	19,0 (3/4")	25,4 (1")	21,7	38,1	23,7	9,52	8,17 - 9,98	173,6
33010.W7515	19,0 (3/4")	38,1 (1,5")	21,7	38,1	23,7	9,52	8,17 - 9,98	173,6
33010.W7520	19,0 (3/4")	50,8 (2")	21,7	38,1	23,7	9,52	8,17 - 9,98	173,6



Detent Pin Steel

Ball Lock Pins & Quick Release



Order No.	d ₁ +0.00 -0.08	l ₁ grip +1.50 -0.00	d ₂	d ₃	l ₂	l ₃	Pull out strength kg	Single shear strength kN min.
33010.W7525	19,0 (3/4")	63,5 (2,5")	21.7	38.1	23.7	9.52	8,17 - 9,98	173.6
33010.W7530	19,0 (3/4")	76,2 (3")	21.7	38.1	23.7	9.52	8,17 - 9,98	173.6
33010.W7535	19,0 (3/4")	88,9 (3,5")	21.7	38.1	23.7	9.52	8,17 - 9,98	173.6
33010.W7540	19,0 (3/4")	101,6 (4")	21.7	38.1	23.7	9.52	8,17 - 9,98	173.6
33010.W7545	19,0 (3/4")	114,3 (4,5")	21.7	38.1	23.7	9.52	8,17 - 9,98	173.6
33010.W7550	19,0 (3/4")	127,0 (5")	21.7	38.1	23.7	9.52	8,17 - 9,98	173.6
33010.W7555	19,0 (3/4")	139,7 (5,5")	21.7	38.1	23.7	9.52	8,17 - 9,98	173.6
33010.W7560	19,0 (3/4")	152,4 (6")	21.7	38.1	23.7	9.52	8,17 - 9,98	173.6
33010.W7570	19,0 (3/4")	177,8 (7")	21.7	38.1	23.7	9.52	8,17 - 9,98	173.6
33010.W7580	19,0 (3/4")	203,2 (8")	21.7	38.1	23.7	9.52	8,17 - 9,98	173.6
33010.W8810	22,2 (7/8")	25,4 (1")	25.2	38.1	25.4	12.7	12,71 - 14,07	239.4
33010.W8815	22,2 (7/8")	38,1 (1,5")	25.2	38.1	25.4	12.7	12,71 - 14,07	239.4
33010.W8820	22,2 (7/8")	50,8 (2")	25.2	38.1	25.4	12.7	12,71 - 14,07	239.4
33010.W8825	22,2 (7/8")	63,5 (2,5")	25.2	38.1	25.4	12.7	12,71 - 14,07	239.4
33010.W8830	22,2 (7/8")	76,2 (3")	25.2	38.1	25.4	12.7	12,71 - 14,07	239.4
33010.W8835	22,2 (7/8")	88,9 (3,5")	25.2	38.1	25.4	12.7	12,71 - 14,07	239.4
33010.W8840	22,2 (7/8")	101,6 (4")	25.2	38.1	25.4	12.7	12,71 - 14,07	239.4
33010.W8845	22,2 (7/8")	114,3 (4,5")	25.2	38.1	25.4	12.7	12,71 - 14,07	239.4
33010.W8850	22,2 (7/8")	127,0 (5")	25.2	38.1	25.4	12.7	12,71 - 14,07	239.4
33010.W8855	22,2 (7/8")	139,7 (5,5")	25.2	38.1	25.4	12.7	12,71 - 14,07	239.4
33010.W8860	22,2 (7/8")	152,4 (6")	25.2	38.1	25.4	12.7	12,71 - 14,07	239.4
33010.W8865	22,2 (7/8")	165,1 (6,5")	25.2	38.1	25.4	12.7	12,71 - 14,07	239.4
33010.W8870	22,2 (7/8")	177,8 (7")	25.2	38.1	25.4	12.7	12,71 - 14,07	239.4
33010.W8880	22,2 (7/8")	203,2 (8")	25.2	38.1	25.4	12.7	12,71 - 14,07	239.4
33010.W1010	25,4 (1")	25,4 (1")	28.9	38.1	31.7	12.7	15,88 - 18-15	321.3
33010.W1015	25,4 (1")	38,1 (1,5")	28.9	38.1	31.7	12.7	15,88 - 18-15	321.3
33010.W1020	25,4 (1")	50,8 (2")	28.9	38.1	31.7	12.7	15,88 - 18-15	321.3
33010.W1025	25,4 (1")	63,5 (2,5")	28.9	38.1	31.7	12.7	15,88 - 18-15	321.3
33010.W1030	25,4 (1")	76,2 (3")	28.9	38.1	31.7	12.7	15,88 - 18-15	321.3
33010.W1035	25,4 (1")	88,9 (3,5")	28.9	38.1	31.7	12.7	15,88 - 18-15	321.3
33010.W1040	25,4 (1")	101,6 (4")	28.9	38.1	31.7	12.7	15,88 - 18-15	321.3
33010.W1045	25,4 (1")	114,3 (4,5")	28.9	38.1	31.7	12.7	15,88 - 18-15	321.3
33010.W1050	25,4 (1")	127,0 (5")	28.9	38.1	31.7	12.7	15,88 - 18-15	321.3
33010.W1055	25,4 (1")	139,7 (5,5")	28.9	38.1	31.7	12.7	15,88 - 18-15	321.3
33010.W1060	25,4 (1")	152,4 (6")	28.9	38.1	31.7	12.7	15,88 - 18-15	321.3
33010.W1070	25,4 (1")	177,8 (7")	28.9	38.1	31.7	12.7	15,88 - 18-15	321.3
33010.W1080	25,4 (1")	203,2 (8")	28.9	38.1	31.7	12.7	15,88 - 18-15	321.3

BALL LOCK PINS & QUICK RELEASE PINS



33014

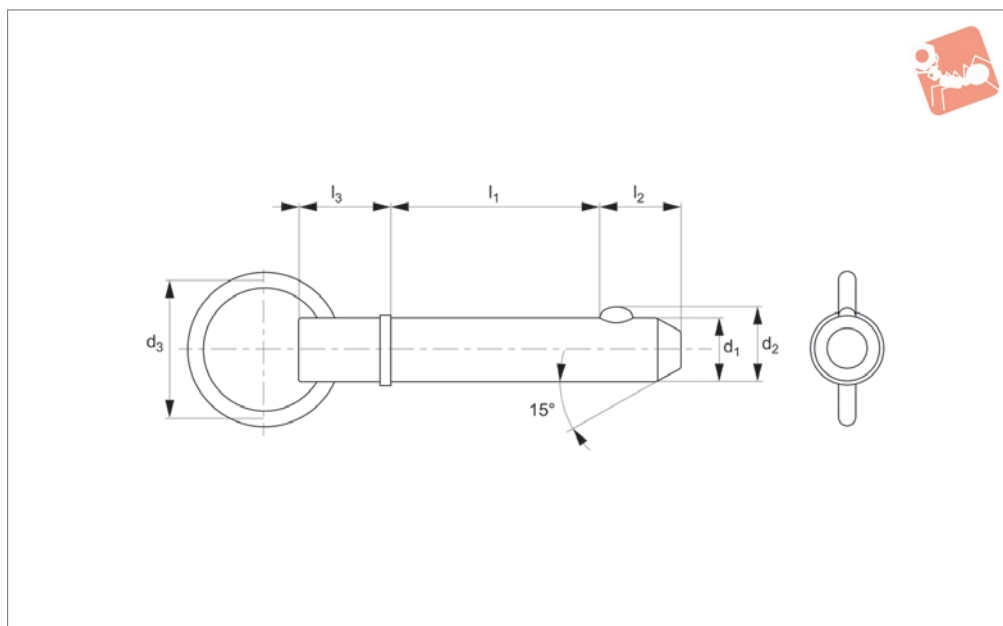

Material

Shaft: Carbon steel (C1144), zinc plated.
Ball & spring: Stainless steel AISI 316.

Technical Notes

Detent pins are very economical for use in commercial and military equipment. The solid body with direct spring loaded

ball ensures reliable operation. Can be used for locking telescopic tubing, securing bracket assemblies, as anchor clevis fittings, hinge pins and as replacement for cotter pins where frequent removal is necessary. Hole sizes - commercial drills provide clear-

ance for our standard pins. Inch dimensions in brackets ().

Tips

Also available in stainless steel see part no. P.

Order No.	d ₁ +0.00 -0.08	l ₁ grip +1.50 -0.00	d ₂	d ₃	l ₂	l ₃	Pull out strength kg	Single shear strength kN min.
33014.W1803	4,76 (3/16")	7,62 (0,3")	5.18	25.4	5.08	17.45	1,9 - 2,3	10.8
33014.W1805	4,76 (3/16")	12,7 (0,5")	5.18	25.4	5.08	17.45	1,9 - 2,3	10.8
33014.W1810	4,76 (3/16")	25,4 (1")	5.18	25.4	5.08	17.45	1,9 - 2,3	10.8
33014.W1815	4,76 (3/16")	38,1 (1,5")	5.18	25.4	5.08	17.45	1,9 - 2,3	10.8
33014.W1820	4,76 (3/16")	50,8 (2")	5.18	25.4	5.08	17.45	1,9 - 2,3	10.8
33014.W1825	4,76 (3/16")	63,5 (2,5")	5.18	25.4	5.08	17.45	1,9 - 2,3	10.8
33014.W1830	4,76 (3/16")	76,2 (3")	5.18	25.4	5.08	17.45	1,9 - 2,3	10.8
33014.W1835	4,76 (3/16")	88,9 (3,5")	5.18	25.4	5.08	17.45	1,9 - 2,3	10.8
33014.W1840	4,76 (3/16")	101,6 (4")	5.18	25.4	5.08	17.45	1,9 - 2,3	10.8
33014.W2505	6,35 (1/4")	12,7 (0,5")	7.26	31.75	7.92	18.29	2,27 - 2,73	19.3
33014.W2506	6,35 (1/4")	15,24 (0,6")	7.26	31.75	7.92	18.29	2,27 - 2,73	19.3
33014.W2510	6,35 (1/4")	25,4 (1")	7.26	31.75	7.92	18.29	2,27 - 2,73	19.3
33014.W2515	6,35 (1/4")	38,1 (1,5")	7.26	31.75	7.92	18.29	2,27 - 2,73	19.3
33014.W2520	6,35 (1/4")	50,8 (2")	7.26	31.75	7.92	18.29	2,27 - 2,73	19.3
33014.W2525	6,35 (1/4")	63,5 (2,5")	7.26	31.75	7.92	18.29	2,27 - 2,73	19.3
33014.W2530	6,35 (1/4")	76,2 (3")	7.26	31.75	7.92	18.29	2,27 - 2,73	19.3
33014.W2535	6,35 (1/4")	88,9 (3,5")	7.26	31.75	7.92	18.29	2,27 - 2,73	19.3
33014.W2540	6,35 (1/4")	101,6 (4")	7.26	31.75	7.92	18.29	2,27 - 2,73	19.3
33014.W3105	7,94 (5/16")	12,7 (0,5")	9.09	31.75	9.53	19.05	2,27 - 2,73	30.0
33014.W3110	7,94 (5/16")	25,4 (1")	9.09	31.75	9.53	19.05	2,27 - 2,73	30.0
33014.W3115	7,94 (5/16")	38,1 (1,5")	9.09	31.75	9.53	19.05	2,27 - 2,73	30.0
33014.W3120	7,94 (5/16")	50,8 (2")	9.09	31.75	9.53	19.05	2,27 - 2,73	30.0
33014.W3125	7,94 (5/16")	63,5 (2,5")	9.09	31.75	9.53	19.05	2,27 - 2,73	30.0
33014.W3130	7,94 (5/16")	76,2 (3")	9.09	31.75	9.53	19.05	2,27 - 2,73	30.0
33014.W3135	7,94 (5/16")	88,9 (3,5")	9.09	31.75	9.53	19.05	2,27 - 2,73	30.0
33014.W3140	7,94 (5/16")	101,6 (4")	9.09	31.75	9.53	19.05	2,27 - 2,73	30.0
33014.W3145	7,94 (5/16")	114,3 (4,5")	9.09	31.75	9.53	19.05	2,27 - 2,73	30.0
33014.W3150	7,94 (5/16")	127 (5")	9.09	31.75	9.53	19.05	2,27 - 2,73	30.0
33014.W3705	9,53 (3,8")	12,7 (0,5")	10.82	44.45	12.7	19.05	3,63 - 4,54	43.3



Order No.	d ₁ +0.00 -0.08	l ₁ grip +1.50 -0.00	d ₂	d ₃	l ₂	l ₃	Pull out strength kg	Single shear strength kN min.
33014.W7525	19,05 (3/4")	63,5 (2,5")	21.74	57.15	23.8	34.93	8,17 - 9,98	173.6
33014.W7530	19,05 (3/4")	76,2 (3")	21.74	57.15	23.8	34.93	8,17 - 9,98	173.6
33014.W7535	19,05 (3/4")	88,9 (3,5")	21.74	57.15	23.8	34.93	8,17 - 9,98	173.6
33014.W7540	19,05 (3/4")	101,6 (4")	21.74	57.15	23.8	34.93	8,17 - 9,98	173.6
33014.W7545	19,05 (3/4")	114,3 (4,5")	21.74	57.15	23.8	34.93	8,17 - 9,98	173.6
33014.W7550	19,05 (3/4")	127 (5")	21.74	57.15	23.8	34.93	8,17 - 9,98	173.6
33014.W7555	19,05 (3/4")	139,7 (5,5")	21.74	57.15	23.8	34.93	8,17 - 9,98	173.6
33014.W7560	19,05 (3/4")	152,4 (6")	21.74	57.15	23.8	34.93	8,17 - 9,98	173.6
33014.W7570	19,05 (3/4")	177,8 (7")	21.74	57.15	23.8	34.93	8,17 - 9,98	173.6
33014.W7580	19,05 (3/4")	203,2 (8")	21.74	57.15	23.8	34.93	8,17 - 9,98	173.6
33014.W8810	22,23 (7/8")	25,4 (1")	25.3	63.5	25.4	38.1	12,71 - 14,07	239.4
33014.W8815	22,23 (7/8")	38,1 (1,5")	25.3	63.5	25.4	38.1	12,71 - 14,07	239.4
33014.W8820	22,23 (7/8")	50,8 (2")	25.3	63.5	25.4	38.1	12,71 - 14,07	239.4
33014.W8825	22,23 (7/8")	63,5 (2,5")	25.3	63.5	25.4	38.1	12,71 - 14,07	239.4
33014.W8830	22,23 (7/8")	76,2 (3")	25.3	63.5	25.4	38.1	12,71 - 14,07	239.4
33014.W8835	22,23 (7/8")	88,9 (3,5")	25.3	63.5	25.4	38.1	12,71 - 14,07	239.4
33014.W8840	22,23 (7/8")	101,6 (4")	25.3	63.5	25.4	38.1	12,71 - 14,07	239.4
33014.W8845	22,23 (7/8")	114,3 (4,5")	25.3	63.5	25.4	38.1	12,71 - 14,07	239.4
33014.W8850	22,23 (7/8")	127 (5")	25.3	63.5	25.4	38.1	12,71 - 14,07	239.4
33014.W8855	22,23 (7/8")	139,7 (5,5")	25.3	63.5	25.4	38.1	12,71 - 14,07	239.4
33014.W8860	22,23 (7/8")	152,4 (6")	25.3	63.5	25.4	38.1	12,71 - 14,07	239.4
33014.W8865	22,23 (7/8")	165,1 (6,5")	25.3	63.5	25.4	38.1	12,71 - 14,07	239.4
33014.W8870	22,23 (7/8")	177,8 (7")	25.3	63.5	25.4	38.1	12,71 - 14,07	239.4
33014.W8880	22,23 (7/8")	203,2 (8")	25.3	63.5	25.4	38.1	12,71 - 14,07	239.4
33014.W1010	25,4 (1")	25,4 (1")	28.96	39	31.75	38.1	15,88 - 18,15	312.3
33014.W1015	25,4 (1")	38,1 (1,5")	28.96	39	31.75	38.1	15,88 - 18,15	312.3
33014.W1020	25,4 (1")	50,8 (2")	28.96	39	31.75	38.1	15,88 - 18,15	312.3
33014.W1025	25,4 (1")	63,5 (2,5")	28.96	39	31.75	38.1	15,88 - 18,15	312.3
33014.W1030	25,4 (1")	76,2 (3")	28.96	39	31.75	38.1	15,88 - 18,15	312.3
33014.W1035	25,4 (1")	88,9 (3,5")	28.96	39	31.75	38.1	15,88 - 18,15	312.3
33014.W1040	25,4 (1")	101,6 (4")	28.96	39	31.75	38.1	15,88 - 18,15	312.3
33014.W1045	25,4 (1")	114,3 (4,5")	28.96	39	31.75	38.1	15,88 - 18,15	312.3
33014.W1050	25,4 (1")	127 (5")	28.96	39	31.75	38.1	15,88 - 18,15	312.3
33014.W1055	25,4 (1")	139,7 (5,5")	28.96	39	31.75	38.1	15,88 - 18,15	312.3
33014.W1060	25,4 (1")	152,4 (6")	28.96	39	31.75	38.1	15,88 - 18,15	312.3
33014.W1070	25,4 (1")	177,8 (7")	28.96	39	31.75	38.1	15,88 - 18,15	312.3
33014.W1080	25,4 (1")	203,2 (8")	28.96	39	31.75	38.1	15,88 - 18,15	312.3



Detent Pin - Ring Handle - Shoulder stainless steel

Ball Lock Pins & Quick Release

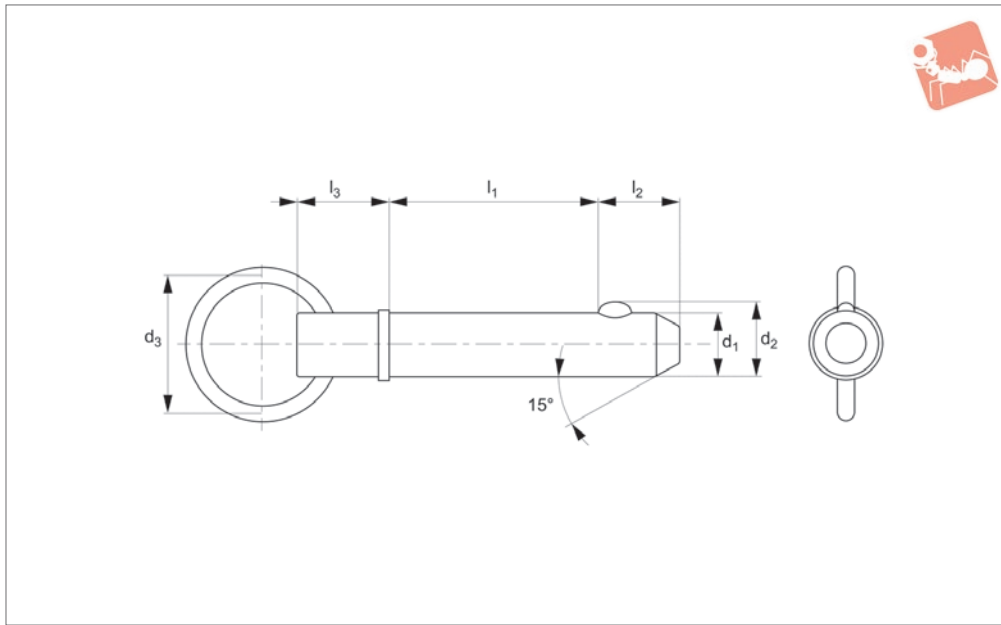

33016

BALL LOCK PINS & QUICK RELEASE PINS

Material

Shaft: Stainless steel, AISI 303.
Ball & Spring: Stainless steel, AISI 316.

Technical Notes

Detent pins are very economical for use in commercial and military equipment.

The solid body with direct spring loaded ball ensures reliable operation. For locking telescopic tubing, securing bracket assemblies, as anchor clevis fittings, hinge pins etc where frequent removal is necessary.

Hole sizes - commercial drills provide clearance for our standard pins. Inch dimensions in brackets ().

Tips

Also available on request in A4 (AISI 316) stainless steel, subject to min. quantity.

Order No.	d ₁ +0.00 -0.08	l ₁ grip +1.50 -0.00	d ₂	d ₃	l ₂	l ₃	Pull out strength kg	Single shear strength kN min.
33016.W1803	4,76 (3/16")	7,62 (0,3")	5.18	25.4	5.08	17.45	1, 9 - 2, 3	12.2
33016.W1805	4,76 (3/16")	12,7 (0,5")	5.18	25.4	5.08	17.45	1, 9 - 2, 3	12.2
33016.W1810	4,76 (3/16")	25,4 (1")	5.18	25.4	5.08	17.45	1, 9 - 2, 3	12.2
33016.W1815	4,76 (3/16")	38,1 (1,5")	5.18	25.4	5.08	17.45	1, 9 - 2, 3	12.2
33016.W1820	4,76 (3/16")	50,8 (2")	5.18	25.4	5.08	17.45	1, 9 - 2, 3	12.2
33016.W1825	4,76 (3/16")	63,5 (2,5")	5.18	25.4	5.08	17.45	1, 9 - 2, 3	12.2
33016.W1830	4,76 (3/16")	76,2 (3")	5.18	25.4	5.08	17.45	1, 9 - 2, 3	12.2
33016.W1835	4,76 (3/16")	88,9 (3,5")	5.18	25.4	5.08	17.45	1, 9 - 2, 3	12.2
33016.W1840	4,76 (3/16")	101,6 (4")	5.18	25.4	5.08	17.45	1, 9 - 2, 3	12.2
33016.W2505	6,35 (1/4")	12,7 (0,5")	7.26	25.4	7.92	18.29	2,27 - 2,73	21.7
33016.W2506	6,35 (1/4")	15,24 (0,6")	7.26	25.4	7.92	18.29	2,27 - 2,73	21.7
33016.W2510	6,35 (1/4")	25,4 (1")	7.26	25.4	7.92	18.29	2,27 - 2,73	21.7
33016.W2515	6,35 (1/4")	38,1 (1,5")	7.26	25.4	7.92	18.29	2,27 - 2,73	21.7
33016.W2520	6,35 (1/4")	50,8 (2")	7.26	25.4	7.92	18.29	2,27 - 2,73	21.7
33016.W2525	6,35 (1/4")	63,5 (2,5")	7.26	25.4	7.92	18.29	2,27 - 2,73	21.7
33016.W2530	6,35 (1/4")	76,2 (3")	7.26	25.4	7.92	18.29	2,27 - 2,73	21.7
33016.W2535	6,35 (1/4")	88,9 (3,5")	7.26	25.4	7.92	18.29	2,27 - 2,73	21.7
33016.W2540	6,35 (1/4")	101,6 (4")	7.26	25.4	7.92	18.29	2,27 - 2,73	21.7
33016.W3105	7,94 (5/16")	12,7 (0,5")	9.09	25.4	9.53	19.05	2,27 - 2,73	33.8
33016.W3110	7,94 (5/16")	25,4 (1")	9.09	25.4	9.53	19.05	2,27 - 2,73	33.8
33016.W3115	7,94 (5/16")	38,1 (1,5")	9.09	25.4	9.53	19.05	2,27 - 2,73	33.8
33016.W3120	7,94 (5/16")	50,8 (2")	9.09	25.4	9.53	19.05	2,27 - 2,73	33.8
33016.W3125	7,94 (5/16")	63,5 (2,5")	9.09	25.4	9.53	19.05	2,27 - 2,73	33.8
33016.W3130	7,94 (5/16")	76,2 (3")	9.09	25.4	9.53	19.05	2,27 - 2,73	33.8
33016.W3135	7,94 (5/16")	88,9 (3,5")	9.09	25.4	9.53	19.05	2,27 - 2,73	33.8
33016.W3140	7,94 (5/16")	101,6 (4")	9.09	25.4	9.53	19.05	2,27 - 2,73	33.8
33016.W3145	7,94 (5/16")	114,3 (4,5")	9.09	25.4	9.53	19.05	2,27 - 2,73	33.8
33016.W3150	7,94 (5/16")	127 (5")	9.09	25.4	9.53	19.05	2,27 - 2,73	33.8
33016.W3705	9,53 (3,8")	12,7 (0,5")	10.82	25.4	12.7	19.05	3,63 - 4,54	49.1
33016.W3706	9,53 (3,8")	15,24 (0,6")	10.82	25.4	12.7	19.05	3,63 - 4,54	49.1



Detent Pin - Ring Handle - Shoulder stainless steel

Ball Lock Pins & Quick Release

Order No.	d ₁ +0.00 -0.08	l ₁ grip +1.50 -0.00	d ₂	d ₃	l ₂	l ₃	Pull out strength kg	Single shear strength kN min.
33016.W7530	19,05 (3/4")	76,2 (3")	21.74	38.1	23.8	34.93	8,17 - 9,98	195.9
33016.W7535	19,05 (3/4")	88,9 (3,5")	21.74	38.1	23.8	34.93	8,17 - 9,98	195.9
33016.W7540	19,05 (3/4")	101,6 (4")	21.74	38.1	23.8	34.93	8,17 - 9,98	195.9
33016.W7545	19,05 (3/4")	114,3 (4,5")	21.74	38.1	23.8	34.93	8,17 - 9,98	195.9
33016.W7550	19,05 (3/4")	127 (5")	21.74	38.1	23.8	34.93	8,17 - 9,98	195.9
33016.W7555	19,05 (3/4")	139,7 (5,5")	21.74	38.1	23.8	34.93	8,17 - 9,98	195.9
33016.W7560	19,05 (3/4")	152,4 (6")	21.74	38.1	23.8	34.93	8,17 - 9,98	195.9
33016.W7570	19,05 (3/4")	177,8 (7")	21.74	38.1	23.8	34.93	8,17 - 9,98	195.9
33016.W7580	19,05 (3/4")	203,2 (8")	21.74	38.1	23.8	34.93	8,17 - 9,98	195.9
33016.W8810	22,23 (7/8")	25,4 (1")	25.3	38.1	25.4	38.1	12,71 - 14,07	262.4
33016.W8815	22,23 (7/8")	38,1 (1,5")	25.3	38.1	25.4	38.1	12,71 - 14,07	262.4
33016.W8820	22,23 (7/8")	50,8 (2")	25.3	38.1	25.4	38.1	12,71 - 14,07	262.4
33016.W8825	22,23 (7/8")	63,5 (2,5")	25.3	38.1	25.4	38.1	12,71 - 14,07	262.4
33016.W8830	22,23 (7/8")	76,2 (3")	25.3	38.1	25.4	38.1	12,71 - 14,07	262.4
33016.W8835	22,23 (7/8")	88,9 (3,5")	25.3	38.1	25.4	38.1	12,71 - 14,07	262.4
33016.W8840	22,23 (7/8")	101,6 (4")	25.3	38.1	25.4	38.1	12,71 - 14,07	262.4
33016.W8845	22,23 (7/8")	114,3 (4,5")	25.3	38.1	25.4	38.1	12,71 - 14,07	262.4
33016.W8850	22,23 (7/8")	127 (5")	25.3	38.1	25.4	38.1	12,71 - 14,07	262.4
33016.W8855	22,23 (7/8")	139,7 (5,5")	25.3	38.1	25.4	38.1	12,71 - 14,07	262.4
33016.W8860	22,23 (7/8")	152,4 (6")	25.3	38.1	25.4	38.1	12,71 - 14,07	262.4
33016.W8865	22,23 (7/8")	165,1 (6,5")	25.3	38.1	25.4	38.1	12,71 - 14,07	262.4
33016.W8870	22,23 (7/8")	177,8 (7")	25.3	38.1	25.4	38.1	12,71 - 14,07	262.4
33016.W8880	22,23 (7/8")	203,2 (8")	25.3	38.1	25.4	38.1	12,71 - 14,07	262.4
33016.W1010	25,4 (1")	25,4 (1")	28.96	38.1	31.75	38.1	15,88 - 18,15	353.0
33016.W1015	25,4 (1")	38,1 (1,5")	28.96	38.1	31.75	38.1	15,88 - 18,15	353.0
33016.W1020	25,4 (1")	50,8 (2")	28.96	38.1	31.75	38.1	15,88 - 18,15	353.0
33016.W1025	25,4 (1")	63,5 (2,5")	28.96	38.1	31.75	38.1	15,88 - 18,15	353.0
33016.W1030	25,4 (1")	76,2 (3")	28.96	38.1	31.75	38.1	15,88 - 18,15	353.0
33016.W1035	25,4 (1")	88,9 (3,5")	28.96	38.1	31.75	38.1	15,88 - 18,15	353.0
33016.W1040	25,4 (1")	101,6 (4")	28.96	38.1	31.75	38.1	15,88 - 18,15	353.0
33016.W1045	25,4 (1")	114,3 (4,5")	28.96	38.1	31.75	38.1	15,88 - 18,15	353.0
33016.W1050	25,4 (1")	127 (5")	28.96	38.1	31.75	38.1	15,88 - 18,15	353.0
33016.W1055	25,4 (1")	139,7 (5,5")	28.96	38.1	31.75	38.1	15,88 - 18,15	353.0
33016.W1060	25,4 (1")	152,4 (6")	28.96	38.1	31.75	38.1	15,88 - 18,15	353.0
33016.W1070	25,4 (1")	177,8 (7")	28.96	38.1	31.75	38.1	15,88 - 18,15	353.0
33016.W1080	25,4 (1")	203,2 (8")	28.96	38.1	31.75	38.1	15,88 - 18,15	353.0

BALL LOCK PINS & QUICK RELEASE PINS



33018

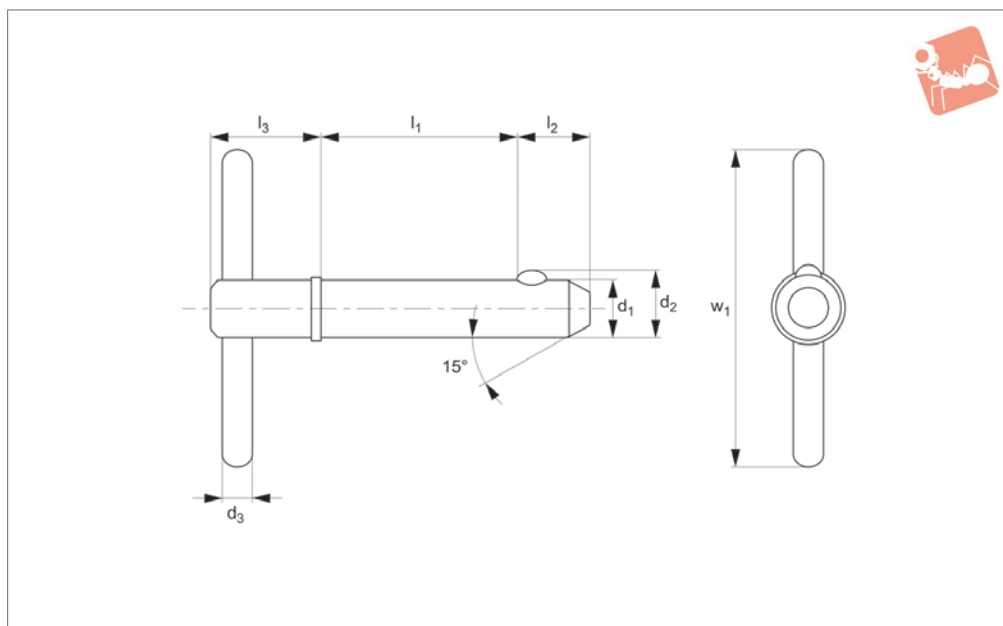

Material

Shaft: Carbon steel (C1144), zinc plated.
Ball & spring: Stainless steel AISI 316.

Technical Notes

Detent pins are very economical for use in commercial and military equipment. The solid body with direct spring loaded

ball ensures reliable operation. Can be used for locking telescopic tubing, securing bracket assemblies, as anchor clevis fittings, hinge pins and as replacement for cotter pins where frequent removal is necessary. Hole sizes - commercial drills provide clea-

rance for our standard pins. Inch dimensions in brackets ().

Tips

Also available in stainless steel see part no. P.

Order No.	d ₁ +0.00 -0.08	l ₁ grip +1.50 -0.00	d ₂	d ₃	l ₂	l ₃	Pull out strength kg	w ₁	Single shear strength kN min.
33018.W1803	4,76 (3/16")	7,62 (0,3")	5.18	2.38	5.08	17.45	1, 9 - 2, 3	25.4	10.8
33018.W1805	4,76 (3/16")	12,7 (0,5")	5.18	2.38	5.08	17.45	1, 9 - 2, 3	25.4	10.8
33018.W1810	4,76 (3/16")	25,4 (1")	5.18	2.38	5.08	17.45	1, 9 - 2, 3	25.4	10.8
33018.W1815	4,76 (3/16")	38,1 (1,5")	5.18	2.38	5.08	17.45	1, 9 - 2, 3	25.4	10.8
33018.W1820	4,76 (3/16")	50,8 (2")	5.18	2.38	5.08	17.45	1, 9 - 2, 3	25.4	10.8
33018.W1825	4,76 (3/16")	63,5 (2,5")	5.18	2.38	5.08	17.45	1, 9 - 2, 3	25.4	10.8
33018.W1830	4,76 (3/16")	76,2 (3")	5.18	2.38	5.08	17.45	1, 9 - 2, 3	25.4	10.8
33018.W1835	4,76 (3/16")	88,9 (3,5")	5.18	2.38	5.08	17.45	1, 9 - 2, 3	25.4	10.8
33018.W1840	4,76 (3/16")	101,6 (4")	5.18	2.38	5.08	17.45	1, 9 - 2, 3	25.4	10.8
33018.W2505	6,35 (1/4")	12,7 (0,5")	7.26	3.17	7.92	18.29	2,27 - 2,73	25.4	19.3
33018.W2506	6,35 (1/4")	15,24 (0,6")	7.26	3.17	7.92	18.29	2,27 - 2,73	25.4	19.3
33018.W2510	6,35 (1/4")	25,4 (1")	7.26	3.17	7.92	18.29	2,27 - 2,73	25.4	19.3
33018.W2515	6,35 (1/4")	38,1 (1,5")	7.26	3.17	7.92	18.29	2,27 - 2,73	25.4	19.3
33018.W2520	6,35 (1/4")	50,8 (2")	7.26	3.17	7.92	18.29	2,27 - 2,73	25.4	19.3
33018.W2525	6,35 (1/4")	63,5 (2,5")	7.26	3.17	7.92	18.29	2,27 - 2,73	25.4	19.3
33018.W2530	6,35 (1/4")	76,2 (3")	7.26	3.17	7.92	18.29	2,27 - 2,73	25.4	19.3
33018.W2535	6,35 (1/4")	88,9 (3,5")	7.26	3.17	7.92	18.29	2,27 - 2,73	25.4	19.3
33018.W2540	6,35 (1/4")	101,6 (4")	7.26	3.17	7.92	18.29	2,27 - 2,73	25.4	19.3
33018.W3105	7,94 (5/16")	12,7 (0,5")	9.09	3.96	9.53	19.05	2,27 - 2,73	25.4	30.0
33018.W3110	7,94 (5/16")	25,4 (1")	9.09	3.96	9.53	19.05	2,27 - 2,73	25.4	30.0
33018.W3115	7,94 (5/16")	38,1 (1,5")	9.09	3.96	9.53	19.05	2,27 - 2,73	25.4	30.0
33018.W3120	7,94 (5/16")	50,8 (2")	9.09	3.96	9.53	19.05	2,27 - 2,73	25.4	30.0
33018.W3125	7,94 (5/16")	63,5 (2,5")	9.09	3.96	9.53	19.05	2,27 - 2,73	25.4	30.0
33018.W3130	7,94 (5/16")	76,2 (3")	9.09	3.96	9.53	19.05	2,27 - 2,73	25.4	30.0
33018.W3135	7,94 (5/16")	88,9 (3,5")	9.09	3.96	9.53	19.05	2,27 - 2,73	25.4	30.0
33018.W3140	7,94 (5/16")	101,6 (4")	9.09	3.96	9.53	19.05	2,27 - 2,73	25.4	30.0
33018.W3145	7,94 (5/16")	114,3 (4,5")	9.09	3.96	9.53	19.05	2,27 - 2,73	25.4	30.0
33018.W3150	7,94 (5/16")	127 (5")	9.09	3.96	9.53	19.05	2,27 - 2,73	25.4	30.0
33018.W3705	9,53 (3,8")	12,7 (0,5")	10.82	3.96	12.7	19.05	3,63 - 4,54	25.4	43.3



Detent Pin - T Handle - Shoulder steel

Ball Lock Pins & Quick Release



Order No.	d_1 +0.00 -0.08	l_1 grip +1.50 -0.00	d_2	d_3	l_2	l_3	Pull out strength kg	w_1	Single shear strength kN min.
33018.W3706	9,53 (3,8")	15,24 (0,6")	10.82	3.96	12.7	19.05	3,63 - 4,54	25.4	43.3
33018.W3710	9,53 (3,8")	25,4 (1")	10.82	3.96	12.7	19.05	3,63 - 4,54	25.4	43.3
33018.W3715	9,53 (3,8")	38,1 (1,5")	10.82	3.96	12.7	19.05	3,63 - 4,54	25.4	43.3
33018.W3718	9,53 (3,8")	45,72 (1,8")	10.82	3.96	12.7	19.05	3,63 - 4,54	25.4	43.3
33018.W3720	9,53 (3,8")	50,8 (2")	10.82	3.96	12.7	19.05	3,63 - 4,54	25.4	43.3
33018.W3725	9,53 (3,8")	63,5 (2,5")	10.82	3.96	12.7	19.05	3,63 - 4,54	25.4	43.3
33018.W3730	9,53 (3,8")	76,2 (3")	10.82	3.96	12.7	19.05	3,63 - 4,54	25.4	43.3
33018.W3735	9,53 (3,8")	88,9 (3,5")	10.82	3.96	12.7	19.05	3,63 - 4,54	25.4	43.3
33018.W3740	9,53 (3,8")	101,6 (4")	10.82	3.96	12.7	19.05	3,63 - 4,54	25.4	43.3
33018.W3745	9,53 (3,8")	114,3 (4,5")	10.82	3.96	12.7	19.05	3,63 - 4,54	25.4	43.3
33018.W3750	9,53 (3,8")	127 (5")	10.82	3.96	12.7	19.05	3,63 - 4,54	25.4	43.3
33018.W3755	9,53 (3,8")	139,7 (5,5")	10.82	3.96	12.7	19.05	3,63 - 4,54	25.4	43.3
33018.W3760	9,53 (3,8")	152,4 (6")	10.82	3.96	12.7	19.05	3,63 - 4,54	25.4	43.3
33018.W4305	11,11(7/16")	12,7 (0,5")	12.6	3.96	14.27	24.13	4,09 - 5,45	25.4	58.9
33018.W4310	11,11(7/16")	25,4 (1")	12.6	3.96	14.27	24.13	4,09 - 5,45	25.4	58.9
33018.W4315	11,11(7/16")	38,1 (1,5")	12.6	3.96	14.27	24.13	4,09 - 5,45	25.4	58.9
33018.W4320	11,11(7/16")	50,8 (2")	12.6	3.96	14.27	24.13	4,09 - 5,45	25.4	58.9
33018.W4325	11,11(7/16")	63,5 (2,5")	12.6	3.96	14.27	24.13	4,09 - 5,45	25.4	58.9
33018.W4330	11,11(7/16")	76,2 (3")	12.6	3.96	14.27	24.13	4,09 - 5,45	25.4	58.9

BALL LOCK PINS & QUICK RELEASE PINS



33020

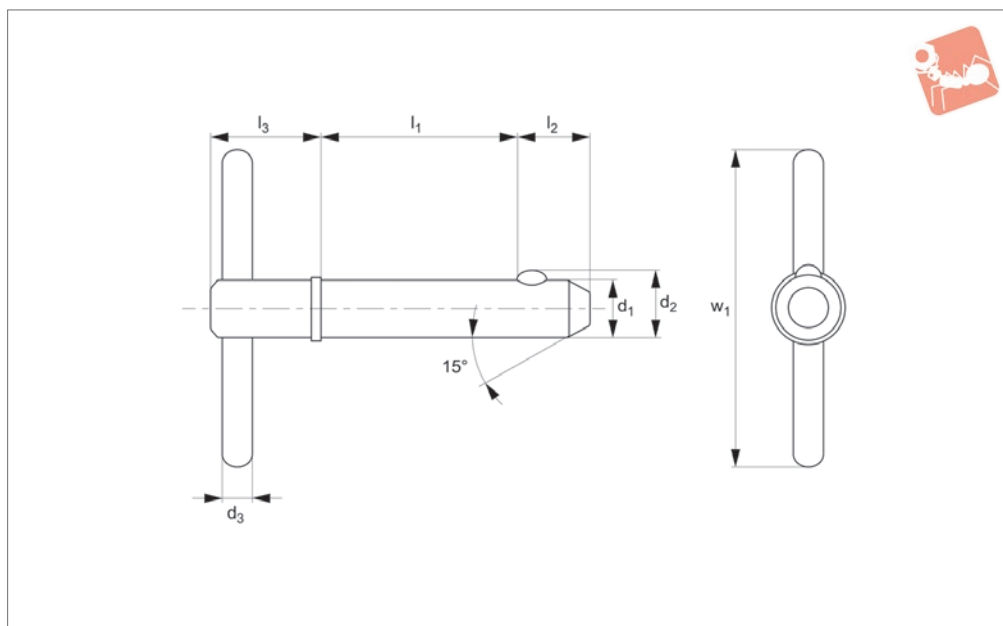

Material

Shaft: Stainless steel, AISI 303.

Ball & Spring: Stainless steel, AISI 316.

Technical Notes

Detent pins are very economical for use in commercial and military equipment.

The solid body with direct spring loaded ball ensures reliable operation.

For locking telescopic tubing, securing bracket assemblies, as anchor clevis fittings, hinge pins etc where frequent removal is necessary.

Hole sizes - commercial drills provide clearance for our standard pins.

Inch dimensions in brackets ().

Tips

Also available on request in A4 (AISI 316) stainless steel, subject to min. quantity.

Order No.	d ₁ +0.00 -0.08	l ₁ grip +1.50 -0.00	d ₂	d ₃	l ₂	l ₃	Pull out strength kg	w ₁	Single shear strength kN min.
33020.W1803	4,76 (3/16")	7,62 (0,3")	5.18	2.38	5.08	17.45	1, 9 - 2, 3	25.4	12.2
33020.W1805	4,76 (3/16")	12,7 (0,5")	5.18	2.38	5.08	17.45	1, 9 - 2, 3	25.4	12.2
33020.W1810	4,76 (3/16")	25,4 (1")	5.18	2.38	5.08	17.45	1, 9 - 2, 3	25.4	12.2
33020.W1815	4,76 (3/16")	38,1 (1,5")	5.18	2.38	5.08	17.45	1, 9 - 2, 3	25.4	12.2
33020.W1820	4,76 (3/16")	50,8 (2")	5.18	2.38	5.08	17.45	1, 9 - 2, 3	25.4	12.2
33020.W1825	4,76 (3/16")	63,5 (2,5")	5.18	2.38	5.08	17.45	1, 9 - 2, 3	25.4	12.2
33020.W1830	4,76 (3/16")	76,2 (3")	5.18	2.38	5.08	17.45	1, 9 - 2, 3	25.4	12.2
33020.W1835	4,76 (3/16")	88,9 (3,5")	5.18	2.38	5.08	17.45	1, 9 - 2, 3	25.4	12.2
33020.W1840	4,76 (3/16")	101,6 (4")	5.18	2.38	5.08	17.45	1, 9 - 2, 3	25.4	12.2
33020.W2505	6,35 (1/4")	12,7 (0,5")	7.26	3.17	7.92	18.29	2,27 - 2,73	25.4	21.7
33020.W2506	6,35 (1/4")	15,24 (0,6")	7.26	3.17	7.92	18.29	2,27 - 2,73	25.4	21.7
33020.W2510	6,35 (1/4")	25,4 (1")	7.26	3.17	7.92	18.29	2,27 - 2,73	25.4	21.7
33020.W2515	6,35 (1/4")	38,1 (1,5")	7.26	3.17	7.92	18.29	2,27 - 2,73	25.4	21.7
33020.W2520	6,35 (1/4")	50,8 (2")	7.26	3.17	7.92	18.29	2,27 - 2,73	25.4	21.7
33020.W2525	6,35 (1/4")	63,5 (2,5")	7.26	3.17	7.92	18.29	2,27 - 2,73	25.4	21.7
33020.W2530	6,35 (1/4")	76,2 (3")	7.26	3.17	7.92	18.29	2,27 - 2,73	25.4	21.7
33020.W2535	6,35 (1/4")	88,9 (3,5")	7.26	3.17	7.92	18.29	2,27 - 2,73	25.4	21.7
33020.W2540	6,35 (1/4")	101,6 (4")	7.26	3.17	7.92	18.29	2,27 - 2,73	25.4	21.7
33020.W3105	7,94 (5/16")	12,7 (0,5")	9.09	3.96	9.53	19.05	2,27 - 2,73	25.4	33.8
33020.W3110	7,94 (5/16")	25,4 (1")	9.09	3.96	9.53	19.05	2,27 - 2,73	25.4	33.8
33020.W3115	7,94 (5/16")	38,1 (1,5")	9.09	3.96	9.53	19.05	2,27 - 2,73	25.4	33.8
33020.W3120	7,94 (5/16")	50,8 (2")	9.09	3.96	9.53	19.05	2,27 - 2,73	25.4	33.8
33020.W3125	7,94 (5/16")	63,5 (2,5")	9.09	3.96	9.53	19.05	2,27 - 2,73	25.4	33.8
33020.W3130	7,94 (5/16")	76,2 (3")	9.09	3.96	9.53	19.05	2,27 - 2,73	25.4	33.8
33020.W3135	7,94 (5/16")	88,9 (3,5")	9.09	3.96	9.53	19.05	2,27 - 2,73	25.4	33.8
33020.W3140	7,94 (5/16")	101,6 (4")	9.09	3.96	9.53	19.05	2,27 - 2,73	25.4	33.8
33020.W3145	7,94 (5/16")	114,3 (4,5")	9.09	3.96	9.53	19.05	2,27 - 2,73	25.4	33.8
33020.W3150	7,94 (5/16")	127 (5")	9.09	3.96	9.53	19.05	2,27 - 2,73	25.4	33.8
33020.W3705	9,53 (3,8")	12,7 (0,5")	10.82	3.96	12.7	19.05	3,63 - 4,54	25.4	49.1
33020.W3706	9,53 (3,8")	15,24 (0,6")	10.82	3.96	12.7	19.05	3,63 - 4,54	25.4	49.1



Order No.	d ₁ +0.00 -0.08	l ₁ grip +1.50 -0.00	d ₂	d ₃	l ₂	l ₃	Pull out strength kg	w ₁	Single shear strength kN min.
33020.W7530	19,05 (3/4")	76,2 (3")	21.74	6.35	23.8	34.93	8,17 - 9,98	38.1	195.9
33020.W7535	19,05 (3/4")	88,9 (3,5")	21.74	6.35	23.8	34.93	8,17 - 9,98	38.1	195.9
33020.W7540	19,05 (3/4")	101,6 (4")	21.74	6.35	23.8	34.93	8,17 - 9,98	38.1	195.9
33020.W7545	19,05 (3/4")	114,3 (4,5")	21.74	6.35	23.8	34.93	8,17 - 9,98	38.1	195.9
33020.W7550	19,05 (3/4")	127 (5")	21.74	6.35	23.8	34.93	8,17 - 9,98	38.1	195.9
33020.W7555	19,05 (3/4")	139,7 (5,5")	21.74	6.35	23.8	34.93	8,17 - 9,98	38.1	195.9
33020.W7560	19,05 (3/4")	152,4 (6")	21.74	6.35	23.8	34.93	8,17 - 9,98	38.1	195.9
33020.W7570	19,05 (3/4")	177,8 (7")	21.74	6.35	23.8	34.93	8,17 - 9,98	38.1	195.9
33020.W7580	19,05 (3/4")	203,2 (8")	21.74	6.35	23.8	34.93	8,17 - 9,98	38.1	195.9
33020.W8810	22,23 (7/8")	25,4 (1")	25.3	9.52	25.4	38.1	12,71 - 14,07	38.1	262.4
33020.W8815	22,23 (7/8")	38,1 (1,5")	25.3	9.52	25.4	38.1	12,71 - 14,07	38.1	262.4
33020.W8820	22,23 (7/8")	50,8 (2")	25.3	9.52	25.4	38.1	12,71 - 14,07	38.1	262.4
33020.W8825	22,23 (7/8")	63,5 (2,5")	25.3	9.52	25.4	38.1	12,71 - 14,07	38.1	262.4
33020.W8830	22,23 (7/8")	76,2 (3")	25.3	9.52	25.4	38.1	12,71 - 14,07	38.1	262.4
33020.W8835	22,23 (7/8")	88,9 (3,5")	25.3	9.52	25.4	38.1	12,71 - 14,07	38.1	262.4
33020.W8840	22,23 (7/8")	101,6 (4")	25.3	9.52	25.4	38.1	12,71 - 14,07	38.1	262.4
33020.W8845	22,23 (7/8")	114,3 (4,5")	25.3	9.52	25.4	38.1	12,71 - 14,07	38.1	262.4
33020.W8850	22,23 (7/8")	127 (5")	25.3	9.52	25.4	38.1	12,71 - 14,07	38.1	262.4
33020.W8855	22,23 (7/8")	139,7 (5,5")	25.3	9.52	25.4	38.1	12,71 - 14,07	38.1	262.4
33020.W8860	22,23 (7/8")	152,4 (6")	25.3	9.52	25.4	38.1	12,71 - 14,07	38.1	262.4
33020.W8865	22,23 (7/8")	165,1 (6,5")	25.3	9.52	25.4	38.1	12,71 - 14,07	38.1	262.4
33020.W8870	22,23 (7/8")	177,8 (7")	25.3	9.52	25.4	38.1	12,71 - 14,07	38.1	262.4
33020.W8880	22,23 (7/8")	203,2 (8")	25.3	9.52	25.4	38.1	12,71 - 14,07	38.1	262.4
33020.W1010	25,4 (1")	25,4 (1")	28.96	9.52	31.75	38.1	15,88 - 18,15	38.1	353.0
33020.W1015	25,4 (1")	38,1 (1,5")	28.96	9.52	31.75	38.1	15,88 - 18,15	38.1	353.0
33020.W1020	25,4 (1")	50,8 (2")	28.96	9.52	31.75	38.1	15,88 - 18,15	38.1	353.0
33020.W1025	25,4 (1")	63,5 (2,5")	28.96	9.52	31.75	38.1	15,88 - 18,15	38.1	353.0
33020.W1030	25,4 (1")	76,2 (3")	28.96	9.52	31.75	38.1	15,88 - 18,15	38.1	353.0
33020.W1035	25,4 (1")	88,9 (3,5")	28.96	9.52	31.75	38.1	15,88 - 18,15	38.1	353.0
33020.W1040	25,4 (1")	101,6 (4")	28.96	9.52	31.75	38.1	15,88 - 18,15	38.1	353.0
33020.W1045	25,4 (1")	114,3 (4,5")	28.96	9.52	31.75	38.1	15,88 - 18,15	38.1	353.0
33020.W1050	25,4 (1")	127 (5")	28.96	9.52	31.75	38.1	15,88 - 18,15	38.1	353.0
33020.W1055	25,4 (1")	139,7 (5,5")	28.96	9.52	31.75	38.1	15,88 - 18,15	38.1	353.0
33020.W1060	25,4 (1")	152,4 (6")	28.96	9.52	31.75	38.1	15,88 - 18,15	38.1	353.0
33020.W1070	25,4 (1")	177,8 (7")	28.96	9.52	31.75	38.1	15,88 - 18,15	38.1	353.0
33020.W1080	25,4 (1")	203,2 (8")	28.96	9.52	31.75	38.1	15,88 - 18,15	38.1	353.0



Detent Pin - L Handle - Shoulder steel

Ball Lock Pins & Quick Release

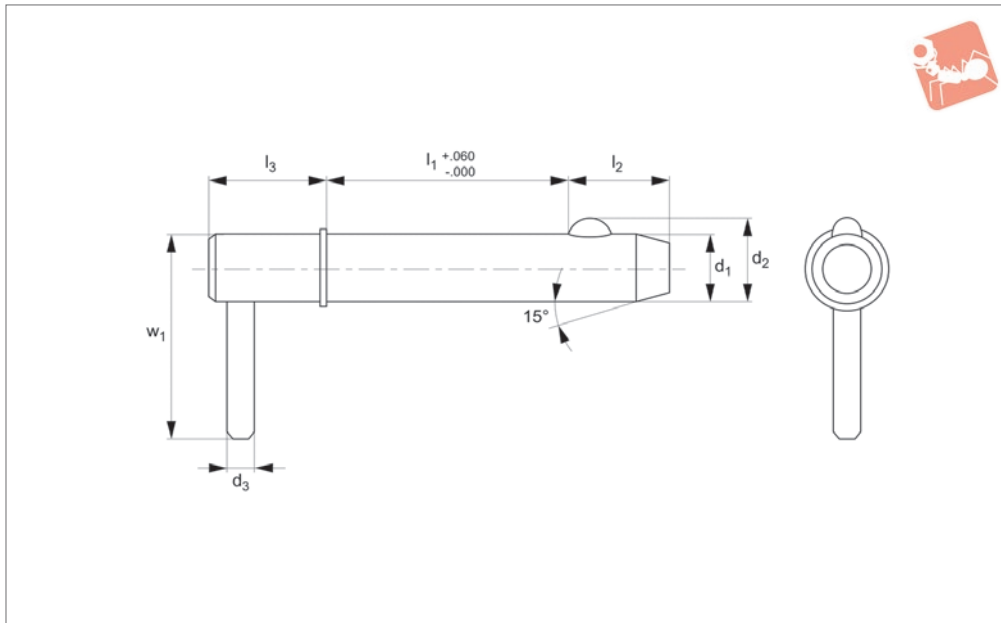

33022

BALL LOCK PINS & QUICK RELEASE PINS

Material

Shaft: Carbon steel (C1144), zinc plated.
Ball & spring: Stainless steel AISI 316.

Technical Notes

Detent Pins are very economical for use in commercial and military equipment. The solid body with direct spring loaded

ball ensures reliable operation. Can be used for locking telescopic tubing, securing bracket assemblies, as anchor clevis fittings, hinge pins and as replacement for cotter pins where frequent removal is necessary. Hole sizes - commercial drills provide clear-

ance for our standard pins. Inch dimensions in brackets ().

Tips

Also available in stainless steel see part no. 33024.

Order No.	d ₁ +0.00 -0.08	l ₁ grip +1.50 -0.00	d ₂	d ₃	l ₂	l ₃	Pull out strength kg	w ₁	Single shear strength kN min.
33022.W1803	4,76 (3/16")	7,62 (0,3")	5.18	2.38	5.08	17.45	1,9 - 2,3	25.4	10.8
33022.W1805	4,76 (3/16")	12,7 (0,5")	5.18	2.38	5.08	17.45	1,9 - 2,3	25.4	10.8
33022.W1810	4,76 (3/16")	25,4 (1")	5.18	2.38	5.08	17.45	1,9 - 2,3	25.4	10.8
33022.W1815	4,76 (3/16")	38,1 (1,5")	5.18	2.38	5.08	17.45	1,9 - 2,3	25.4	10.8
33022.W1820	4,76 (3/16")	50,8 (2")	5.18	2.38	5.08	17.45	1,9 - 2,3	25.4	10.8
33022.W1825	4,76 (3/16")	63,5 (2,5")	5.18	2.38	5.08	17.45	1,9 - 2,3	25.4	10.8
33022.W1830	4,76 (3/16")	76,2 (3")	5.18	2.38	5.08	17.45	1,9 - 2,3	25.4	10.8
33022.W1835	4,76 (3/16")	88,9 (3,5")	5.18	2.38	5.08	17.45	1,9 - 2,3	25.4	10.8
33022.W1840	4,76 (3/16")	101,6 (4")	5.18	2.38	5.08	17.45	1,9 - 2,3	25.4	10.8
33022.W2505	6,35 (1/4")	12,7 (0,5")	7.26	3.17	7.92	18.29	2,27 - 2,73	25.4	19.3
33022.W2506	6,35 (1/4")	15,24 (0,6")	7.26	3.17	7.92	18.29	2,27 - 2,73	25.4	19.3
33022.W2510	6,35 (1/4")	25,4 (1")	7.26	3.17	7.92	18.29	2,27 - 2,73	25.4	19.3
33022.W2515	6,35 (1/4")	38,1 (1,5")	7.26	3.17	7.92	18.29	2,27 - 2,73	25.4	19.3
33022.W2520	6,35 (1/4")	50,8 (2")	7.26	3.17	7.92	18.29	2,27 - 2,73	25.4	19.3
33022.W2525	6,35 (1/4")	63,5 (2,5")	7.26	3.17	7.92	18.29	2,27 - 2,73	25.4	19.3
33022.W2530	6,35 (1/4")	76,2 (3")	7.26	3.17	7.92	18.29	2,27 - 2,73	25.4	19.3
33022.W2535	6,35 (1/4")	88,9 (3,5")	7.26	3.17	7.92	18.29	2,27 - 2,73	25.4	19.3
33022.W2540	6,35 (1/4")	101,6 (4")	7.26	3.17	7.92	18.29	2,27 - 2,73	25.4	19.3
33022.W3105	7,94 (5/16")	12,7 (0,5")	9.09	3.96	9.53	19.05	2,27 - 2,73	25.4	30.0
33022.W3110	7,94 (5/16")	25,4 (1")	9.09	3.96	9.53	19.05	2,27 - 2,73	25.4	30.0
33022.W3115	7,94 (5/16")	38,1 (1,5")	9.09	3.96	9.53	19.05	2,27 - 2,73	25.4	30.0
33022.W3120	7,94 (5/16")	50,8 (2")	9.09	3.96	9.53	19.05	2,27 - 2,73	25.4	30.0
33022.W3125	7,94 (5/16")	63,5 (2,5")	9.09	3.96	9.53	19.05	2,27 - 2,73	25.4	30.0
33022.W3130	7,94 (5/16")	76,2 (3")	9.09	3.96	9.53	19.05	2,27 - 2,73	25.4	30.0
33022.W3135	7,94 (5/16")	88,9 (3,5")	9.09	3.96	9.53	19.05	2,27 - 2,73	25.4	30.0
33022.W3140	7,94 (5/16")	101,6 (4")	9.09	3.96	9.53	19.05	2,27 - 2,73	25.4	30.0
33022.W3145	7,94 (5/16")	114,3 (4,5")	9.09	3.96	9.53	19.05	2,27 - 2,73	25.4	30.0
33022.W3150	7,94 (5/16")	127 (5")	9.09	3.96	9.53	19.05	2,27 - 2,73	25.4	30.0
33022.W3705	9,53 (3,8")	12,7 (0,5")	10.82	3.96	12.7	19.05	3,63 - 4,54	25.4	43.3

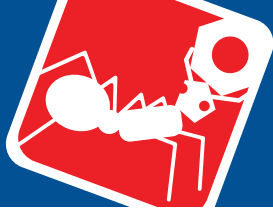

Detent Pin - L Handle - Shoulder steel

Ball Lock Pins & Quick Release

Order No.	d ₁ +0.00 -0.08	l ₁ grip +1.50 -0.00	d ₂	d ₃	l ₂	l ₃	Pull out strength kg	w ₁	Single shear strength kN min.
33022.W7525	19,05 (3/4")	63,5 (2,5")	21.74	6.35	23.8	34.93	8,17 - 9,98	38.1	173.6
33022.W7530	19,05 (3/4")	76,2 (3")	21.74	6.35	23.8	34.93	8,17 - 9,98	38.1	173.6
33022.W7535	19,05 (3/4")	88,9 (3,5")	21.74	6.35	23.8	34.93	8,17 - 9,98	38.1	173.6
33022.W7540	19,05 (3/4")	101,6 (4")	21.74	6.35	23.8	34.93	8,17 - 9,98	38.1	173.6
33022.W7545	19,05 (3/4")	114,3 (4,5")	21.74	6.35	23.8	34.93	8,17 - 9,98	38.1	173.6
33022.W7550	19,05 (3/4")	127 (5")	21.74	6.35	23.8	34.93	8,17 - 9,98	38.1	173.6
33022.W7555	19,05 (3/4")	139,7 (5,5")	21.74	6.35	23.8	34.93	8,17 - 9,98	38.1	173.6
33022.W7560	19,05 (3/4")	152,4 (6")	21.74	6.35	23.8	34.93	8,17 - 9,98	38.1	173.6
33022.W7570	19,05 (3/4")	177,8 (7")	21.74	6.35	23.8	34.93	8,17 - 9,98	38.1	173.6
33022.W7580	19,05 (3/4")	203,2 (8")	21.74	6.35	23.8	34.93	8,17 - 9,98	38.1	173.6
33022.W8810	22,23 (7/8")	25,4 (1")	25.3	9.52	25.4	38.1	12,71 - 14,07	38.1	239.4
33022.W8815	22,23 (7/8")	38,1 (1,5")	25.3	9.52	25.4	38.1	12,71 - 14,07	38.1	239.4
33022.W8820	22,23 (7/8")	50,8 (2")	25.3	9.52	25.4	38.1	12,71 - 14,07	38.1	239.4
33022.W8825	22,23 (7/8")	63,5 (2,5")	25.3	9.52	25.4	38.1	12,71 - 14,07	38.1	239.4
33022.W8830	22,23 (7/8")	76,2 (3")	25.3	9.52	25.4	38.1	12,71 - 14,07	38.1	239.4
33022.W8835	22,23 (7/8")	88,9 (3,5")	25.3	9.52	25.4	38.1	12,71 - 14,07	38.1	239.4
33022.W8840	22,23 (7/8")	101,6 (4")	25.3	9.52	25.4	38.1	12,71 - 14,07	38.1	239.4
33022.W8845	22,23 (7/8")	114,3 (4,5")	25.3	9.52	25.4	38.1	12,71 - 14,07	38.1	239.4
33022.W8850	22,23 (7/8")	127 (5")	25.3	9.52	25.4	38.1	12,71 - 14,07	38.1	239.4
33022.W8855	22,23 (7/8")	139,7 (5,5")	25.3	9.52	25.4	38.1	12,71 - 14,07	38.1	239.4
33022.W8860	22,23 (7/8")	152,4 (6")	25.3	9.52	25.4	38.1	12,71 - 14,07	38.1	239.4
33022.W8865	22,23 (7/8")	165,1 (6,5")	25.3	9.52	25.4	38.1	12,71 - 14,07	38.1	239.4
33022.W8870	22,23 (7/8")	177,8 (7")	25.3	9.52	25.4	38.1	12,71 - 14,07	38.1	239.4
33022.W8880	22,23 (7/8")	203,2 (8")	25.3	9.52	25.4	38.1	12,71 - 14,07	38.1	239.4
33022.W1010	25,4 (1")	25,4 (1")	28.96	9.52	31.75	38.1	15,88 - 18,15	38.1	312.3
33022.W1015	25,4 (1")	38,1 (1,5")	28.96	9.52	31.75	38.1	15,88 - 18,15	38.1	312.3
33022.W1020	25,4 (1")	50,8 (2")	28.96	9.52	31.75	38.1	15,88 - 18,15	38.1	312.3
33022.W1025	25,4 (1")	63,5 (2,5")	28.96	9.52	31.75	38.1	15,88 - 18,15	38.1	312.3
33022.W1030	25,4 (1")	76,2 (3")	28.96	9.52	31.75	38.1	15,88 - 18,15	38.1	312.3
33022.W1035	25,4 (1")	88,9 (3,5")	28.96	9.52	31.75	38.1	15,88 - 18,15	38.1	312.3
33022.W1040	25,4 (1")	101,6 (4")	28.96	9.52	31.75	38.1	15,88 - 18,15	38.1	312.3
33022.W1045	25,4 (1")	114,3 (4,5")	28.96	9.52	31.75	38.1	15,88 - 18,15	38.1	312.3
33022.W1050	25,4 (1")	127 (5")	28.96	9.52	31.75	38.1	15,88 - 18,15	38.1	312.3
33022.W1055	25,4 (1")	139,7 (5,5")	28.96	9.52	31.75	38.1	15,88 - 18,15	38.1	312.3
33022.W1060	25,4 (1")	152,4 (6")	28.96	9.52	31.75	38.1	15,88 - 18,15	38.1	312.3
33022.W1070	25,4 (1")	177,8 (7")	28.96	9.52	31.75	38.1	15,88 - 18,15	38.1	312.3
33022.W1080	25,4 (1")	203,2 (8")	28.96	9.52	31.75	38.1	15,88 - 18,15	38.1	312.3

BALL LOCK PINS & QUICK RELEASE PINS



33024

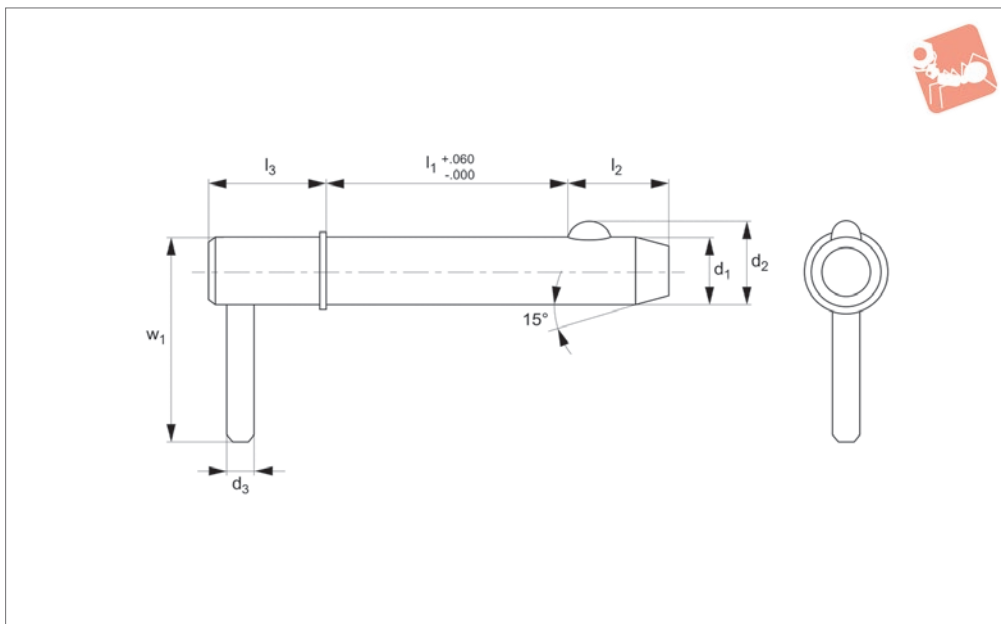

Material

Shaft: Stainless steel, AISI 303.

Ball & Spring: Stainless steel, AISI 316.

Technical Notes

Detent pins are very economical for use in commercial and military equipment.

The solid body with direct spring loaded ball ensures reliable operation.

For locking telescopic tubing, securing bracket assemblies, as anchor clevis fittings, hinge pins etc where frequent removal is necessary.

Hole sizes - commercial drills provide clearance for our standard pins.

Inch dimensions in brackets ().

Tips

Also available on request in A4 (AISI 316) stainless steel, subject to min. quantity.

Order No.	d_1 +0.00 -0.08	l_1 +1.5 -0.0	d_2	d_3	l_2	l_3	Pull out strength kg	w_1	Single shear strength kN min.
33024.W1803	4,76 (3/16")	7,62 (0,3")	5.18	2.38	5.08	17.45	1, 9 - 2, 3	25.4	12.2
33024.W1805	4,76 (3/16")	12,7 (0,5")	5.18	2.38	5.08	17.45	1, 9 - 2, 3	25.4	12.2
33024.W1810	4,76 (3/16")	25,4 (1")	5.18	2.38	5.08	17.45	1, 9 - 2, 3	25.4	12.2
33024.W1815	4,76 (3/16")	38,1 (1,5")	5.18	2.38	5.08	17.45	1, 9 - 2, 3	25.4	12.2
33024.W1820	4,76 (3/16")	50,8 (2")	5.18	2.38	5.08	17.45	1, 9 - 2, 3	25.4	12.2
33024.W1825	4,76 (3/16")	63,5 (2,5")	5.18	2.38	5.08	17.45	1, 9 - 2, 3	25.4	12.2
33024.W1830	4,76 (3/16")	76,2 (3")	5.18	2.38	5.08	17.45	1, 9 - 2, 3	25.4	12.2
33024.W1835	4,76 (3/16")	88,9 (3,5")	5.18	2.38	5.08	17.45	1, 9 - 2, 3	25.4	12.2
33024.W1840	4,76 (3/16")	101,6 (4")	5.18	2.38	5.08	17.45	1, 9 - 2, 3	25.4	12.2
33024.W2505	6,35 (1/4")	12,7 (0,5")	7.26	3.17	7.92	18.29	2,27 - 2,73	25.4	21.7
33024.W2506	6,35 (1/4")	15,24 (0,6")	7.26	3.17	7.92	18.29	2,27 - 2,73	25.4	21.7
33024.W2510	6,35 (1/4")	25,4 (1")	7.26	3.17	7.92	18.29	2,27 - 2,73	25.4	21.7
33024.W2515	6,35 (1/4")	38,1 (1,5")	7.26	3.17	7.92	18.29	2,27 - 2,73	25.4	21.7
33024.W2520	6,35 (1/4")	50,8 (2")	7.26	3.17	7.92	18.29	2,27 - 2,73	25.4	21.7
33024.W2525	6,35 (1/4")	63,5 (2,5")	7.26	3.17	7.92	18.29	2,27 - 2,73	25.4	21.7
33024.W2530	6,35 (1/4")	76,2 (3")	7.26	3.17	7.92	18.29	2,27 - 2,73	25.4	21.7
33024.W2535	6,35 (1/4")	88,9 (3,5")	7.26	3.17	7.92	18.29	2,27 - 2,73	25.4	21.7
33024.W2540	6,35 (1/4")	101,6 (4")	7.26	3.17	7.92	18.29	2,27 - 2,73	25.4	21.7
33024.W3105	7,94 (5/16")	12,7 (0,5")	9.09	3.96	9.53	19.05	2,27 - 2,73	25.4	33.8
33024.W3110	7,94 (5/16")	25,4 (1")	9.09	3.96	9.53	19.05	2,27 - 2,73	25.4	33.8
33024.W3115	7,94 (5/16")	38,1 (1,5")	9.09	3.96	9.53	19.05	2,27 - 2,73	25.4	33.8
33024.W3120	7,94 (5/16")	50,8 (2")	9.09	3.96	9.53	19.05	2,27 - 2,73	25.4	33.8
33024.W3125	7,94 (5/16")	63,5 (2,5")	9.09	3.96	9.53	19.05	2,27 - 2,73	25.4	33.8
33024.W3130	7,94 (5/16")	76,2 (3")	9.09	3.96	9.53	19.05	2,27 - 2,73	25.4	33.8
33024.W3135	7,94 (5/16")	88,9 (3,5")	9.09	3.96	9.53	19.05	2,27 - 2,73	25.4	33.8
33024.W3140	7,94 (5/16")	101,6 (4")	9.09	3.96	9.53	19.05	2,27 - 2,73	25.4	33.8
33024.W3145	7,94 (5/16")	114,3 (4,5")	9.09	3.96	9.53	19.05	2,27 - 2,73	25.4	33.8
33024.W3150	7,94 (5/16")	127 (5")	9.09	3.96	9.53	19.05	2,27 - 2,73	25.4	33.8
33024.W3705	9,53 (3,8")	12,7 (0,5")	10.82	3.96	12.7	19.05	3,63 - 4,54	25.4	49.1
33024.W3706	9,53 (3,8")	15,24 (0,6")	10.82	3.96	12.7	19.05	3,63 - 4,54	25.4	49.1



Order No.	d_1 +0.00 -0.08	l_1 +1.5 -0.0	d_2	d_3	l_2	l_3	Pull out strength kg	w_1	Single shear strength kN min.
33024.W7530	19,05 (3/4")	76,2 (3")	21.74	6.35	23.8	34.93	8,17 - 9,98	38.1	195.9
33024.W7535	19,05 (3/4")	88,9 (3,5")	21.74	6.35	23.8	34.93	8,17 - 9,98	38.1	195.9
33024.W7540	19,05 (3/4")	101,6 (4")	21.74	6.35	23.8	34.93	8,17 - 9,98	38.1	195.9
33024.W7545	19,05 (3/4")	114,3 (4,5")	21.74	6.35	23.8	34.93	8,17 - 9,98	38.1	195.9
33024.W7550	19,05 (3/4")	127 (5")	21.74	6.35	23.8	34.93	8,17 - 9,98	38.1	195.9
33024.W7555	19,05 (3/4")	139,7 (5,5")	21.74	6.35	23.8	34.93	8,17 - 9,98	38.1	195.9
33024.W7560	19,05 (3/4")	152,4 (6")	21.74	6.35	23.8	34.93	8,17 - 9,98	38.1	195.9
33024.W7570	19,05 (3/4")	177,8 (7")	21.74	6.35	23.8	34.93	8,17 - 9,98	38.1	195.9
33024.W7580	19,05 (3/4")	203,2 (8")	21.74	6.35	23.8	34.93	8,17 - 9,98	38.1	195.9
33024.W8810	22,23 (7/8")	25,4 (1")	25.3	9.52	25.4	38.1	12,71 - 14,07	38.1	262.4
33024.W8815	22,23 (7/8")	38,1 (1,5")	25.3	9.52	25.4	38.1	12,71 - 14,07	38.1	262.4
33024.W8820	22,23 (7/8")	50,8 (2")	25.3	9.52	25.4	38.1	12,71 - 14,07	38.1	262.4
33024.W8825	22,23 (7/8")	63,5 (2,5")	25.3	9.52	25.4	38.1	12,71 - 14,07	38.1	262.4
33024.W8830	22,23 (7/8")	76,2 (3")	25.3	9.52	25.4	38.1	12,71 - 14,07	38.1	262.4
33024.W8835	22,23 (7/8")	88,9 (3,5")	25.3	9.52	25.4	38.1	12,71 - 14,07	38.1	262.4
33024.W8840	22,23 (7/8")	101,6 (4")	25.3	9.52	25.4	38.1	12,71 - 14,07	38.1	262.4
33024.W8845	22,23 (7/8")	114,3 (4,5")	25.3	9.52	25.4	38.1	12,71 - 14,07	38.1	262.4
33024.W8850	22,23 (7/8")	127 (5")	25.3	9.52	25.4	38.1	12,71 - 14,07	38.1	262.4
33024.W8855	22,23 (7/8")	139,7 (5,5")	25.3	9.52	25.4	38.1	12,71 - 14,07	38.1	262.4
33024.W8860	22,23 (7/8")	152,4 (6")	25.3	9.52	25.4	38.1	12,71 - 14,07	38.1	262.4
33024.W8865	22,23 (7/8")	165,1 (6,5")	25.3	9.52	25.4	38.1	12,71 - 14,07	38.1	262.4
33024.W8870	22,23 (7/8")	177,8 (7")	25.3	9.52	25.4	38.1	12,71 - 14,07	38.1	262.4
33024.W8880	22,23 (7/8")	203,2 (8")	25.3	9.52	25.4	38.1	12,71 - 14,07	38.1	262.4
33024.W1010	25,4 (1")	25,4 (1")	28.96	9.52	31.75	38.1	15,88 - 18,15	38.1	353.0
33024.W1015	25,4 (1")	38,1 (1,5")	28.96	9.52	31.75	38.1	15,88 - 18,15	38.1	353.0
33024.W1020	25,4 (1")	50,8 (2")	28.96	9.52	31.75	38.1	15,88 - 18,15	38.1	353.0
33024.W1025	25,4 (1")	63,5 (2,5")	28.96	9.52	31.75	38.1	15,88 - 18,15	38.1	353.0
33024.W1030	25,4 (1")	76,2 (3")	28.96	9.52	31.75	38.1	15,88 - 18,15	38.1	353.0
33024.W1035	25,4 (1")	88,9 (3,5")	28.96	9.52	31.75	38.1	15,88 - 18,15	38.1	353.0
33024.W1040	25,4 (1")	101,6 (4")	28.96	9.52	31.75	38.1	15,88 - 18,15	38.1	353.0
33024.W1045	25,4 (1")	114,3 (4,5")	28.96	9.52	31.75	38.1	15,88 - 18,15	38.1	353.0
33024.W1050	25,4 (1")	127 (5")	28.96	9.52	31.75	38.1	15,88 - 18,15	38.1	353.0
33024.W1055	25,4 (1")	139,7 (5,5")	28.96	9.52	31.75	38.1	15,88 - 18,15	38.1	353.0
33024.W1060	25,4 (1")	152,4 (6")	28.96	9.52	31.75	38.1	15,88 - 18,15	38.1	353.0
33024.W1070	25,4 (1")	177,8 (7")	28.96	9.52	31.75	38.1	15,88 - 18,15	38.1	353.0
33024.W1080	25,4 (1")	203,2 (8")	28.96	9.52	31.75	38.1	15,88 - 18,15	38.1	353.0



Detent Pin Stainless Steel

Ball Lock Pins & Quick Release

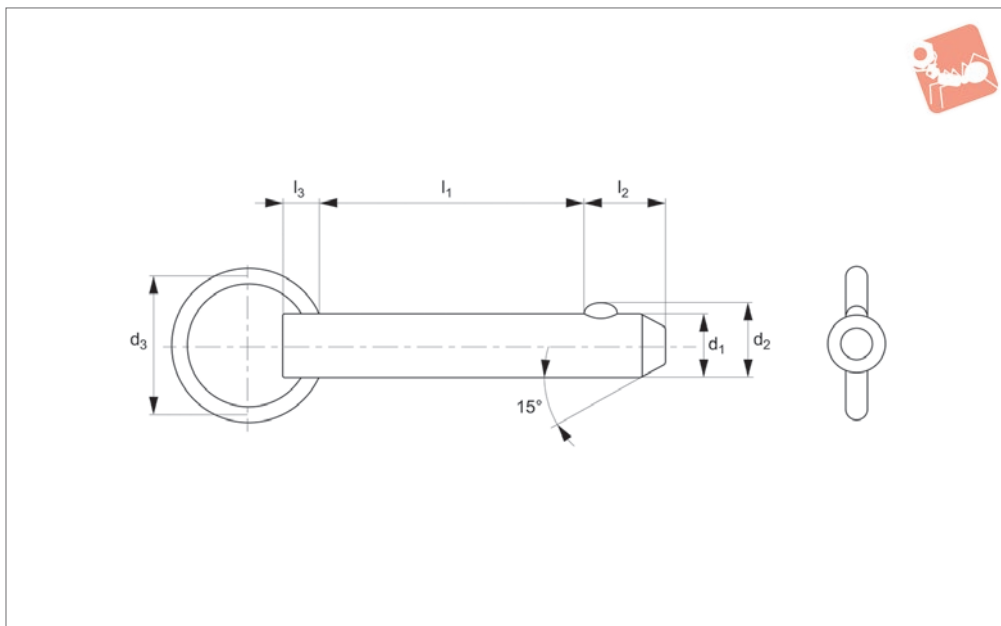

33012.1

BALL LOCK PINS & QUICK RELEASE PINS

Material

Shaft: Stainless steel, AISI 303.

Ball & Spring: Stainless steel, AISI 316.

Technical Notes

Detent pins are very economical for use in commercial and military equipment.

The solid body with direct spring loaded ball ensures reliable operation.

For locking telescopic tubing, securing bracket assemblies, as anchor clevis fittings, hinge pins etc where frequent removal is necessary.

Hole sizes - commercial drills provide clearance for our standard pins.

Inch dimensions in brackets ().

Tips

Also available on request in A4 (AISI 316) stainless steel, subject to min. quantity.

Order No.	d ₁ +0.00 -0.08	l ₁ grip +1.5 -0.0	d ₂	d ₃	l ₂	l ₃	Pull out strength kg	Single shear strength kN min.
33012.W1803	4,76 (3/16")	7,62 (0,3")	5.18	25.4	5.08	4.74	1,9 - 2,3	12.2
33012.W1805	4,76 (3/16")	12,7 (0,5")	5.18	25.4	5.08	4.74	1,9 - 2,3	12.2
33012.W1810	4,76 (3/16")	25,4 (1")	5.18	25.4	5.08	4.74	1,9 - 2,3	12.2
33012.W1815	4,76 (3/16")	38,1 (1,5")	5.18	25.4	5.08	4.74	1,9 - 2,3	12.2
33012.W1820	4,76 (3/16")	50,8 (2")	5.18	25.4	5.08	4.74	1,9 - 2,3	12.2
33012.W1825	4,76 (3/16")	63,5 (2,5")	5.18	25.4	5.08	4.74	1,9 - 2,3	12.2
33012.W1830	4,76 (3/16")	76,2 (3")	5.18	25.4	5.08	4.74	1,9 - 2,3	12.2
33012.W1835	4,76 (3/16")	88,9 (3,5")	5.18	25.4	5.08	4.74	1,9 - 2,3	12.2
33012.W1840	4,76 (3/16")	101,6 (4")	5.18	25.4	5.08	4.74	1,9 - 2,3	12.2
33012.W2505	6,35 (1/4")	12,7 (0,5")	7.26	25.4	7.92	5.58	2,27 - 2,73	21.7
33012.W2510	6,35 (1/4")	25,4 (1")	7.26	25.4	7.92	5.58	2,27 - 2,73	21.7
33012.W2515	6,35 (1/4")	38,1 (1,5")	7.26	25.4	7.92	5.58	2,27 - 2,73	21.7
33012.W2520	6,35 (1/4")	50,8 (2")	7.26	25.4	7.92	5.58	2,27 - 2,73	21.7
33012.W2525	6,35 (1/4")	63,5 (2,5")	7.26	25.4	7.92	5.58	2,27 - 2,73	21.7
33012.W2530	6,35 (1/4")	76,2 (3")	7.26	25.4	7.92	5.58	2,27 - 2,73	21.7
33012.W2535	6,35 (1/4")	88,9 (3,5")	7.26	25.4	7.92	5.58	2,27 - 2,73	21.7
33012.W2540	6,35 (1/4")	101,6 (4")	7.26	25.4	7.92	5.58	2,27 - 2,73	21.7
33012.W3105	7,93 (5/16")	12,7 (0,5")	9.09	25.4	9.52	6.35	2,27 - 2,73	33.8
33012.W3110	7,93 (5/16")	25,4 (1")	9.09	25.4	9.52	6.35	2,27 - 2,73	33.8
33012.W3115	7,93 (5/16")	38,1 (1,5")	9.09	25.4	9.52	6.35	2,27 - 2,73	33.8
33012.W3120	7,93 (5/16")	50,8 (2")	9.09	25.4	9.52	6.35	2,27 - 2,73	33.8
33012.W3125	7,93 (5/16")	63,5 (2,5")	9.09	25.4	9.52	6.35	2,27 - 2,73	33.8
33012.W3130	7,93 (5/16")	76,2 (3")	9.09	25.4	9.52	6.35	2,27 - 2,73	33.8
33012.W3135	7,93 (5/16")	88,9 (3,5")	9.09	25.4	9.52	6.35	2,27 - 2,73	33.8
33012.W3140	7,93 (5/16")	101,6 (4")	9.09	25.4	9.52	6.35	2,27 - 2,73	33.8
33012.W3145	7,93 (5/16")	114,3 (4,5")	9.09	25.4	9.52	6.35	2,27 - 2,73	33.8
33012.W3150	7,93 (5/16")	127,0 (5")	9.09	25.4	9.52	6.35	2,27 - 2,73	33.8
33012.W3705	9,52 (3/8")	12,7 (0,5")	10.8	25.4	12.7	6.35	3,63 - 4,54	49.1
33012.W3710	9,52 (3/8")	25,4 (1")	10.8	25.4	12.7	6.35	3,63 - 4,54	49.1
33012.W3715	9,52 (3/8")	38,1 (1,5")	10.8	25.4	12.7	6.35	3,63 - 4,54	49.1



Order No.	d ₁ +0.00 -0.08	l ₁ grip +1.5 -0.0	d ₂	d ₃	l ₂	l ₃	Pull out strength kg	Single shear strength kN min.
33012.W3720	9,52 (3/8")	50,8 (2")	10.8	25.4	12.7	6.35	3,63 - 4,54	49.1
33012.W3725	9,52 (3/8")	63,5 (2,5")	10.8	25.4	12.7	6.35	3,63 - 4,54	49.1
33012.W3730	9,52 (3/8")	76,2 (3")	10.8	25.4	12.7	6.35	3,63 - 4,54	49.1
33012.W3735	9,52 (3/8")	88,9 (3,5")	10.8	25.4	12.7	6.35	3,63 - 4,54	49.1
33012.W3740	9,52 (3/8")	101,6 (4")	10.8	25.4	12.7	6.35	3,63 - 4,54	49.1
33012.W3745	9,52 (3/8")	114,3 (4,5")	10.8	25.4	12.7	6.35	3,63 - 4,54	49.1
33012.W3750	9,52 (3/8")	127,0 (5")	10.8	25.4	12.7	6.35	3,63 - 4,54	49.1
33012.W3755	9,52 (3/8")	139,7 (5,5")	10.8	25.4	12.7	6.35	3,63 - 4,54	49.1
33012.W3760	9,52 (3/8")	152,4 (6")	10.8	25.4	12.7	6.35	3,63 - 4,54	49.1
33012.W4305	11,1 (7/16")	12,7 (0,5")	12.5	25.4	14.2	6.35	4,09 - 5,45	66.5
33012.W4310	11,1 (7/16")	25,4 (1")	12.5	25.4	14.2	6.35	4,09 - 5,45	66.5
33012.W4315	11,1 (7/16")	38,1 (1,5")	12.5	25.4	14.2	6.35	4,09 - 5,45	66.5
33012.W4320	11,1 (7/16")	50,8 (2")	12.5	25.4	14.2	6.35	4,09 - 5,45	66.5
33012.W4325	11,1 (7/16")	63,5 (2,5")	12.5	25.4	14.2	6.35	4,09 - 5,45	66.5
33012.W4330	11,1 (7/16")	76,2 (3")	12.5	25.4	14.2	6.35	4,09 - 5,45	66.5
33012.W4335	11,1 (7/16")	88,9 (3,5")	12.5	25.4	14.2	6.35	4,09 - 5,45	66.5
33012.W4340	11,1 (7/16")	101,6 (4")	12.5	25.4	14.2	6.35	4,09 - 5,45	66.5
33012.W4345	11,1 (7/16")	114,3 (4,5")	12.5	25.4	14.2	6.35	4,09 - 5,45	66.5
33012.W4350	11,1 (7/16")	127,0 (5")	12.5	25.4	14.2	6.35	4,09 - 5,45	66.5
33012.W4355	11,1 (7/16")	139,7 (5,5")	12.5	25.4	14.2	6.35	4,09 - 5,45	66.5
33012.W4360	11,1 (7/16")	152,4 (6")	12.5	25.4	14.2	6.35	4,09 - 5,45	66.5
33012.W5005	12,7 (1/2")	12,7 (0,5")	14.4	31.7	15.8	7.92	4,54 - 5,45	87.1
33012.W5010	12,7 (1/2")	25,4 (1")	14.4	31.7	15.8	7.92	4,54 - 5,45	87.1
33012.W5015	12,7 (1/2")	38,1 (1,5")	14.4	31.7	15.8	7.92	4,54 - 5,45	87.1
33012.W5020	12,7 (1/2")	50,8 (2")	14.4	31.7	15.8	7.92	4,54 - 5,45	87.1
33012.W5025	12,7 (1/2")	63,5 (2,5")	14.4	31.7	15.8	7.92	4,54 - 5,45	87.1
33012.W5030	12,7 (1/2")	76,2 (3")	14.4	31.7	15.8	7.92	4,54 - 5,45	87.1
33012.W5035	12,7 (1/2")	88,9 (3,5")	14.4	31.7	15.8	7.92	4,54 - 5,45	87.1
33012.W5040	12,7 (1/2")	101,6 (4")	14.4	31.7	15.8	7.92	4,54 - 5,45	87.1
33012.W5045	12,7 (1/2")	114,3 (4,5")	14.4	31.7	15.8	7.92	4,54 - 5,45	87.1
33012.W5050	12,7 (1/2")	127,0 (5")	14.4	31.7	15.8	7.92	4,54 - 5,45	87.1
33012.W5055	12,7 (1/2")	139,7 (5,5")	14.4	31.7	15.8	7.92	4,54 - 5,45	87.1
33012.W5060	12,7 (1/2")	152,4 (6")	14.4	31.7	15.8	7.92	4,54 - 5,45	87.1
33012.W5065	12,7 (1/2")	165,1 (6,5")	14.4	31.7	15.8	7.92	4,54 - 5,45	87.1
33012.W5070	12,7 (1/2")	177,8 (7")	14.4	31.7	15.8	7.92	4,54 - 5,45	87.1



Detent Pin Stainless Steel

Ball Lock Pins & Quick Release

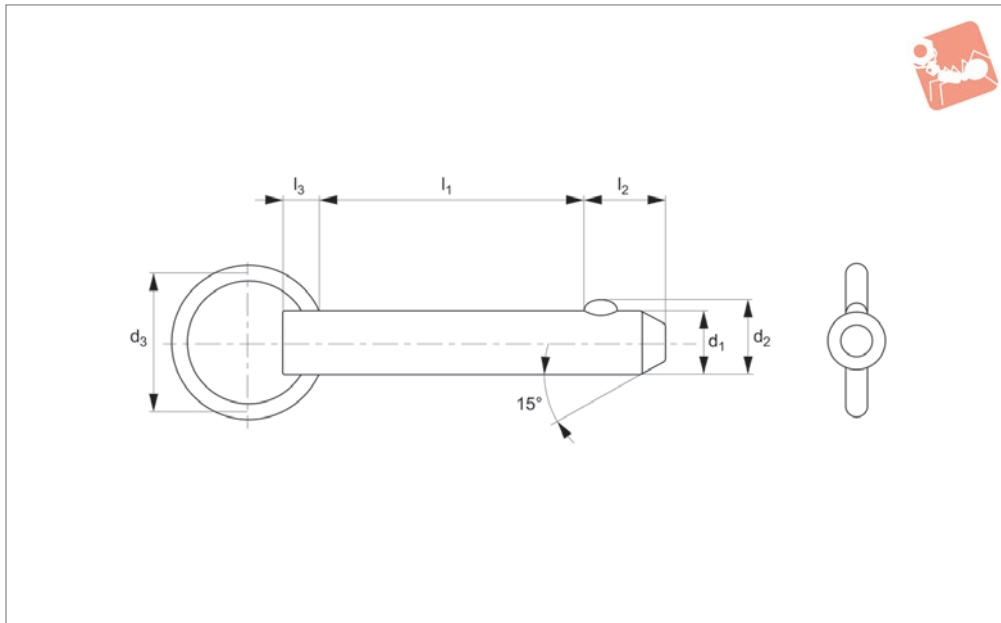

33012.2

BALL LOCK PINS & QUICK RELEASE PINS

Material

Shaft: Stainless steel, AISI 303.

Ball & Spring: Stainless steel, AISI 316.

Technical Notes

Detent pins are very economical for use in commercial and military equipment.

The solid body with direct spring loaded ball ensures reliable operation.

For locking telescopic tubing, securing bracket assemblies, as anchor clevis fittings, hinge pins etc where frequent removal is necessary.

Hole sizes - commercial drills provide clearance for our standard pins.

Inch dimensions in brackets ().

Tips

Also available on request in A4 (AISI 316) stainless steel, subject to min. quantity.

Order No.	d_1 +0.00 -0.08	l_1 grip +1.5 -0.0	d_2	d_3	l_2	l_3	Pull out strength kg	Single shear strength kN min.
33012.W5610	14,2 (9/16")	25,4 (1,0")	16,3	31,7	17,4	7,92	5,45 - 6,81	110,3
33012.W5615	14,2 (9/16")	38,1 (1,5")	16,3	31,7	17,4	7,92	5,45 - 6,81	110,3
33012.W5620	14,2 (9/16")	50,8 (2,0")	16,3	31,7	17,4	7,92	5,45 - 6,81	110,3
33012.W5625	14,2 (9/16")	63,5 (2,5")	16,3	31,7	17,4	7,92	5,45 - 6,81	110,3
33012.W5630	14,2 (9/16")	76,2 (3,0")	16,3	31,7	17,4	7,92	5,45 - 6,81	110,3
33012.W5635	14,2 (9/16")	88,9 (3,5")	16,3	31,7	17,4	7,92	5,45 - 6,81	110,3
33012.W5640	14,2 (9/16")	101,6 (4,0")	16,3	31,7	17,4	7,92	5,45 - 6,81	110,3
33012.W5645	14,2 (9/16")	114,3 (4,5")	16,3	31,7	17,4	7,92	5,45 - 6,81	110,3
33012.W5650	14,2 (9/16")	127,0 (5,0")	16,3	31,7	17,4	7,92	5,45 - 6,81	110,3
33012.W5655	14,2 (9/16")	139,7 (5,5")	16,3	31,7	17,4	7,92	5,45 - 6,81	110,3
33012.W5660	14,2 (9/16")	152,4 (6,0")	16,3	31,7	17,4	7,92	5,45 - 6,81	110,3
33012.W5670	14,2 (9/16")	177,8 (7,0")	16,3	31,7	17,4	7,92	5,45 - 6,81	110,3
33012.W6210	15,8 (5/8")	25,4 (1,0")	18,0	31,7	19,0	9,52	6,36 - 7,26	137,3
33012.W6215	15,8 (5/8")	38,1 (1,5")	18,0	31,7	19,0	9,52	6,36 - 7,26	137,3
33012.W6220	15,8 (5/8")	50,8 (2,0")	18,0	31,7	19,0	9,52	6,36 - 7,26	137,3
33012.W6225	15,8 (5/8")	63,5 (2,5")	18,0	31,7	19,0	9,52	6,36 - 7,26	137,3
33012.W6230	15,8 (5/8")	76,2 (3,0")	18,0	31,7	19,0	9,52	6,36 - 7,26	137,3
33012.W6235	15,8 (5/8")	88,9 (3,5")	18,0	31,7	19,0	9,52	6,36 - 7,26	137,3
33012.W6240	15,8 (5/8")	101,6 (4,0")	18,0	31,7	19,0	9,52	6,36 - 7,26	137,3
33012.W6245	15,8 (5/8")	114,3 (4,5")	18,0	31,7	19,0	9,52	6,36 - 7,26	137,3
33012.W6250	15,8 (5/8")	127,0 (5,0")	18,0	31,7	19,0	9,52	6,36 - 7,26	137,3
33012.W6255	15,8 (5/8")	139,7 (5,5")	18,0	31,7	19,0	9,52	6,36 - 7,26	137,3
33012.W6260	15,8 (5/8")	152,4 (6,0")	18,0	31,7	19,0	9,52	6,36 - 7,26	137,3
33012.W6265	15,8 (5/8")	165,1 (6,5")	18,0	31,7	19,0	9,52	6,36 - 7,26	137,3
33012.W6270	15,8 (5/8")	177,8 (7,0")	18,0	31,7	19,0	9,52	6,36 - 7,26	137,3
33012.W6280	15,8 (5/8")	203,2 (8,0")	18,0	31,7	19,0	9,52	6,36 - 7,26	137,3
33012.W7510	19,0 (3/4")	25,4 (1,0")	21,7	38,1	23,7	9,52	8,17 - 9,98	195,9
33012.W7515	19,0 (3/4")	38,1 (1,5")	21,7	38,1	23,7	9,52	8,17 - 9,98	195,9
33012.W7520	19,0 (3/4")	50,8 (2,0")	21,7	38,1	23,7	9,52	8,17 - 9,98	195,9
33012.W7525	19,0 (3/4")	63,5 (2,5")	21,7	38,1	23,7	9,52	8,17 - 9,98	195,9



Order No.	d ₁ +0.00 -0.08	l ₁ grip +1.5 -0.0	d ₂	d ₃	l ₂	l ₃	Pull out strength kg	Single shear strength kN min.
33012.W7530	19,0 (3/4")	76,2 (3,0")	21.7	38.1	23.7	9.52	8,17 - 9,98	195.9
33012.W7535	19,0 (3/4")	88,9 (3,5")	21.7	38.1	23.7	9.52	8,17 - 9,98	195.9
33012.W7540	19,0 (3/4")	101,6 (4,0")	21.7	38.1	23.7	9.52	8,17 - 9,98	195.9
33012.W7545	19,0 (3/4")	114,3 (4,5")	21.7	38.1	23.7	9.52	8,17 - 9,98	195.9
33012.W7550	19,0 (3/4")	127,0 (5,0")	21.7	38.1	23.7	9.52	8,17 - 9,98	195.9
33012.W7555	19,0 (3/4")	139,7 (5,5")	21.7	38.1	23.7	9.52	8,17 - 9,98	195.9
33012.W7560	19,0 (3/4")	152,4 (6,0")	21.7	38.1	23.7	9.52	8,17 - 9,98	195.9
33012.W7570	19,0 (3/4")	177,8 (7,0")	21.7	38.1	23.7	9.52	8,17 - 9,98	195.9
33012.W7580	19,0 (3/4")	203,2 (8,0")	21.7	38.1	23.7	9.52	8,17 - 9,98	195.9
33012.W8810	22,2 (7/8")	25,4 (1,0")	25.2	38.1	25.4	12.7	12,71 - 14,07	262.4
33012.W8815	22,2 (7/8")	38,1 (1,5")	25.2	38.1	25.4	12.7	12,71 - 14,07	262.4
33012.W8820	22,2 (7/8")	50,8 (2,0")	25.2	38.1	25.4	12.7	12,71 - 14,07	262.4
33012.W8825	22,2 (7/8")	63,5 (2,5")	25.2	38.1	25.4	12.7	12,71 - 14,07	262.4
33012.W8830	22,2 (7/8")	76,2 (3,0")	25.2	38.1	25.4	12.7	12,71 - 14,07	262.4
33012.W8835	22,2 (7/8")	88,9 (3,5")	25.2	38.1	25.4	12.7	12,71 - 14,07	262.4
33012.W8840	22,2 (7/8")	101,6 (4,0")	25.2	38.1	25.4	12.7	12,71 - 14,07	262.4
33012.W8845	22,2 (7/8")	114,3 (4,5")	25.2	38.1	25.4	12.7	12,71 - 14,07	262.4
33012.W8850	22,2 (7/8")	127,0 (5,0")	25.2	38.1	25.4	12.7	12,71 - 14,07	262.4
33012.W8855	22,2 (7/8")	139,7 (5,5")	25.2	38.1	25.4	12.7	12,71 - 14,07	262.4
33012.W8860	22,2 (7/8")	152,4 (6,0")	25.2	38.1	25.4	12.7	12,71 - 14,07	262.4
33012.W8865	22,2 (7/8")	165,1 (6,5")	25.2	38.1	25.4	12.7	12,71 - 14,07	262.4
33012.W8870	22,2 (7/8")	177,8 (7,0")	25.2	38.1	25.4	12.7	12,71 - 14,07	262.4
33012.W8880	22,2 (7/8")	203,2 (8,0")	25.2	38.1	25.4	12.7	12,71 - 14,07	262.4
33012.W1010	25,4 (1")	25,4 (1,0")	28.9	38.1	31.7	12.7	15,88 - 18,15	353.0
33012.W1015	25,4 (1")	38,1 (1,5")	28.9	38.1	31.7	12.7	15,88 - 18,15	353.0
33012.W1020	25,4 (1")	50,8 (2,0")	28.9	38.1	31.7	12.7	15,88 - 18,15	353.0
33012.W1025	25,4 (1")	63,5 (2,5")	28.9	38.1	31.7	12.7	15,88 - 18,15	353.0
33012.W1030	25,4 (1")	76,2 (3,0")	28.9	38.1	31.7	12.7	15,88 - 18,15	353.0
33012.W1035	25,4 (1")	88,9 (3,5")	28.9	38.1	31.7	12.7	15,88 - 18,15	353.0
33012.W1040	25,4 (1")	101,6 (4,0")	28.9	38.1	31.7	12.7	15,88 - 18,15	353.0
33012.W1045	25,4 (1")	114,3 (4,5")	28.9	38.1	31.7	12.7	15,88 - 18,15	353.0
33012.W1050	25,4 (1")	127,0 (5,0")	28.9	38.1	31.7	12.7	15,88 - 18,15	353.0
33012.W1055	25,4 (1")	139,7 (5,5")	28.9	38.1	31.7	12.7	15,88 - 18,15	353.0
33012.W1060	25,4 (1")	152,4 (6,0")	28.9	38.1	31.7	12.7	15,88 - 18,15	353.0
33012.W1070	25,4 (1")	177,8 (7,0")	28.9	38.1	31.7	12.7	15,88 - 18,15	353.0
33012.W1080	25,4 (1")	203,2 (8,0")	28.9	38.1	31.7	12.7	15,88 - 18,15	353.0

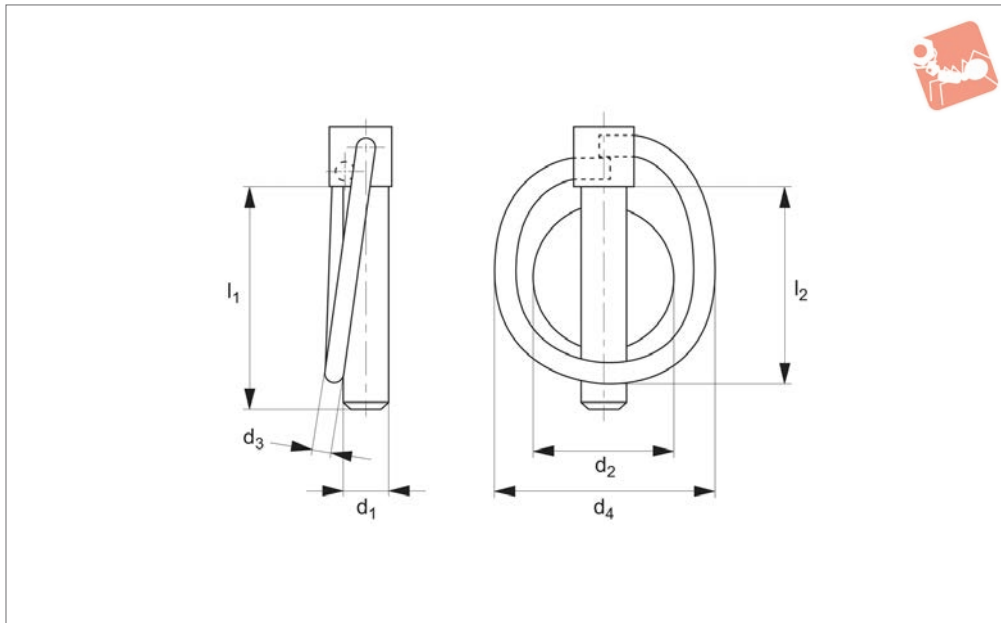

33300

BALL LOCK PINS & QUICK RELEASE PINS

Material

Mild steel, generally yellow zinc plated.

For pin $d_1 = 4,5$ & 6 there is no flat on the pin.

Technical Notes

To DIN 11023. With spring steel „keep“.

Order No.	d_1	l_1	d_2 max.	d_3	d_4	l_2
33300.W0004	4.5	42	25	3.5	41	37
33300.W0006	6.0	42	32	3.5	41	37
33300.W0007	7.0	42	32	3.5	41	37
33300.W0009	9.0	42	32	3.5	41	37
33300.W0010	10.0	42	32	3.5	41	37
33300.W0011	11.0	42	32	3.5	41	37



33320

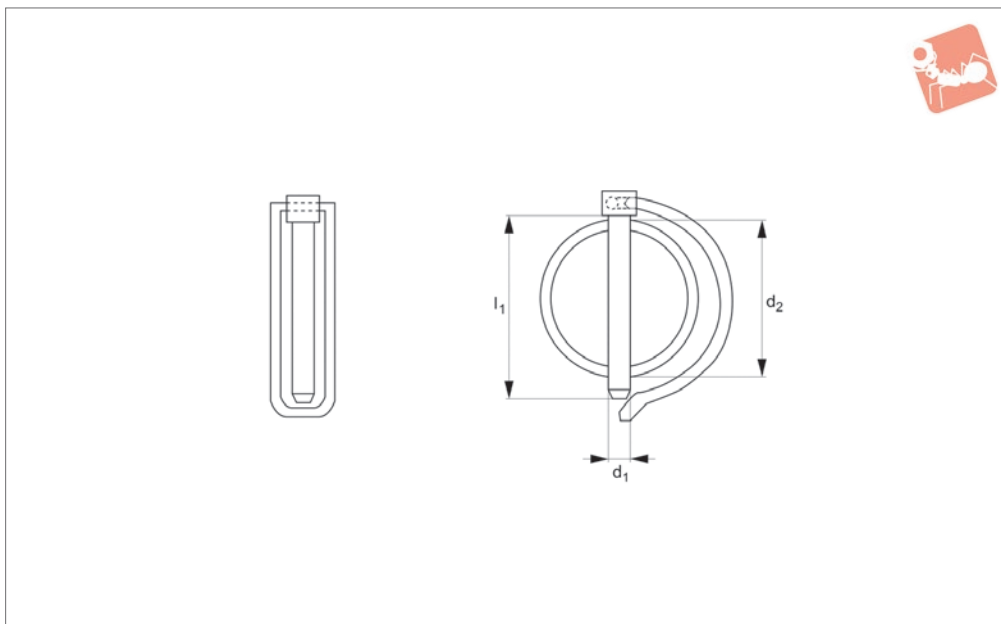

Material

Mild steel, generally silver zinc-plated.
Zinc plating colour will be at manufac-

turers discretion.

Technical Notes

With spring steel „keep“.

Order No.	d ₁	l ₁	d ₂ max.
33320.W0041	4.5	32	28
33320.W0042	4.5	40	36
33320.W0061	6.0	32	28
33320.W0062	6.0	40	36
33320.W0063	6.0	45	40
33320.W0080	8.0	40	36
33320.W0081	8.0	45	40
33320.W0082	8.0	50	45
33320.W0083	8.0	60	50
33320.W0101	10.0	40	36
33320.W0102	10.0	50	45
33320.W0103	10.0	60	55
33320.W0111	11.0	45	40
33320.W0112	11.0	55	50

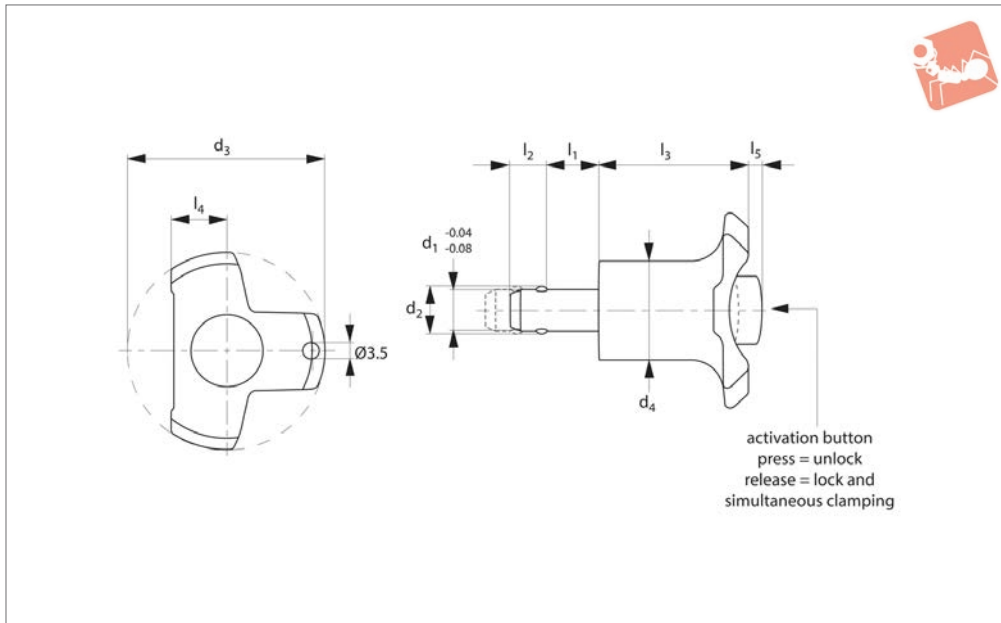

33180

BALL LOCK PINS & QUICK RELEASE PINS

Material

Pin: stainless steel 1,4305 (AISI 303).
Handle: thermoplastic PA 6, grey.
Spring: stainless steel.

Technical Notes

Pressing = unlocking & fixing.

Releasing = locking and simultaneous clamping.

Temperature resistance: -30°C to +80°C.

Locks and simultaneously clamps thin walled plates, with clamping distance of up to 5mm. Applications in welding work,

protection of covers and to close doors.

Tips

For lanyards & retaining cables see part no. 33250.

Order No.	d ₁	l ₁	d ₂	d ₃	d ₄	l ₂	l ₃	l ₄	l ₅ unclamped	Location hole tol. H11	Clamping force N max.	Weight g
33180.W0010	6	0 - 5	7.0	38	17.5	5.0	30.2	11.0	3	6	16	19
33180.W0012	6	5 - 10	7.0	38	17.5	5.0	30.2	11.0	3	6	18	23
33180.W0020	8	0 - 5	9.5	38	17.5	6.5	30.2	11.0	3	8	16	22
33180.W0022	8	5 - 10	9.5	38	17.5	6.5	30.2	11.0	3	8	18	25
33180.W0030	10	0 - 5	12.0	47	23.0	8.7	36.0	11.0	4	10	21	45
33180.W0032	10	5 - 10	12.0	47	23.0	8.7	36.0	11.0	4	10	23	47
33180.W0040	12	0 - 5	14.0	47	23.0	9.4	36.0	13.5	4	12	21	47
33180.W0042	12	5 - 10	14.0	47	23.0	9.4	36.0	13.5	4	12	23	54





BALL LOCK PINS & QUICK RELEASE PINS



33170

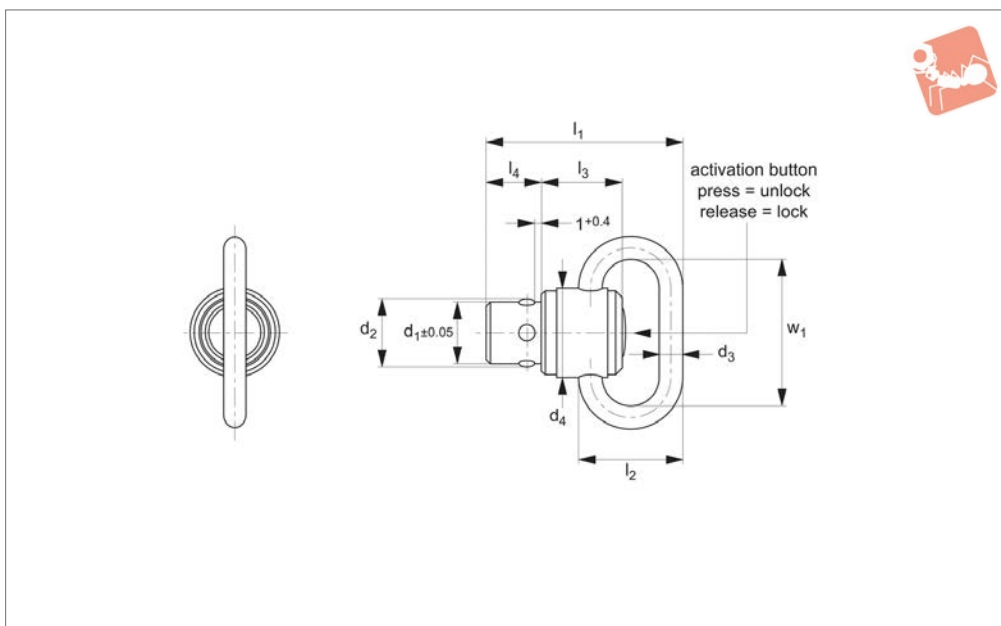

Material

Pin: Stainless Steel 1.4305 (AISI 303)
 Spring: Stainless Steel
 Finish: Black or Natural

Technical Notes

Temperature range -50°C to +150°C.

For quick fastening and locking of frequently repeated connections; gun slings, tool holders etc, used in combination with sling swivel receivers no.33172.
 Pressing = Unlocking

Releasing = Locking

Order No.	Finish	Nom. pin dia	$d_1 \pm 0.05$	w_1	d_2	d_3	d_4	l_1	l_2	l_3	l_4	Load capacity kN max.	Weight g
33170.W0010	Black	9.5	9.5	23	11.1	3.5	14	31.3	16.5	12.5	9	1.2	20
33170.W0020	Black	9.5	9.5	40	11.1	4.5	14	36.6	23.0	12.5	9	2.0	29
33170.W0110	Natural	9.5	9.5	23	11.1	3.5	14	31.3	16.5	12.5	9	1.2	20
33170.W0120	Natural	9.5	9.5	40	11.1	4.5	14	36.6	23.0	12.5	9	2.0	29



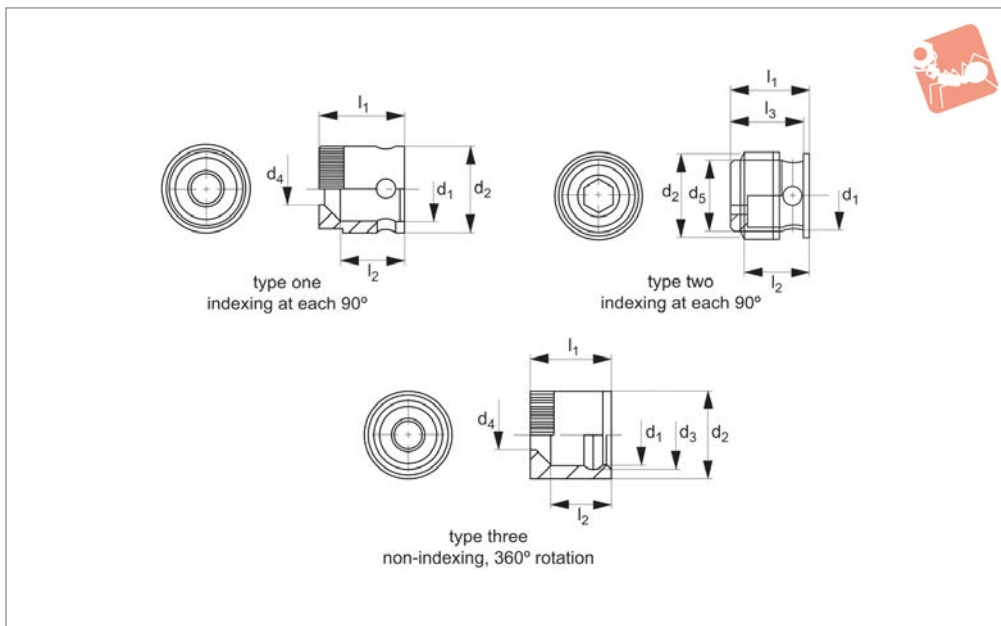

33172

BALL LOCK PINS & QUICK RELEASE PINS

Material

Pin: stainless steel 1.4305.
Spring: stainless steel.
Finish: Black or natural.

Technical Notes

Temperature range -50°C to +150°C.

Receivers for sling swivel pins part no. 33170.

To achieve quick fastening and locking frequently repeated connections.
Type one and two: indexing at 90°.
Type three: non-indexing, 360° rotation.

Order No.	Dia. Ø nom.	Finish	For mounting in	Type	d ₁ tol. h9	d ₂ ±0.1	d ₃	d ₄	d ₅	l ₁	l ₂	l ₃	A/F	Weight g
33172.W0205	9.5	Black	Wood	One	9.6	12.65	-	4.9	-	12.65	9.65	-	-	5.6
33172.W0210	9.5	Black	Plastic	Two	9.6	12.65	-	-	10.7	12.10	9.20	11	5	3.0
33172.W0215	9.5	Black	Wood 360°	Three	9.6	13.50	11.3	4.9	-	12.65	9.65	-	-	6.5
33172.W0305	9.5	Natural	Wood	One	9.6	12.65	-	4.9	-	12.65	9.65	-	-	5.6
33172.W0310	9.5	Natural	Plastic	Two	9.6	12.65	-	-	10.7	12.10	9.20	11	5	3.0
33172.W0315	9.5	Natural	Wood 360°	Three	9.6	13.50	11.3	4.9	-	12.65	9.65	-	-	6.5



BALL LOCK PINS & QUICK RELEASE PINS



33178

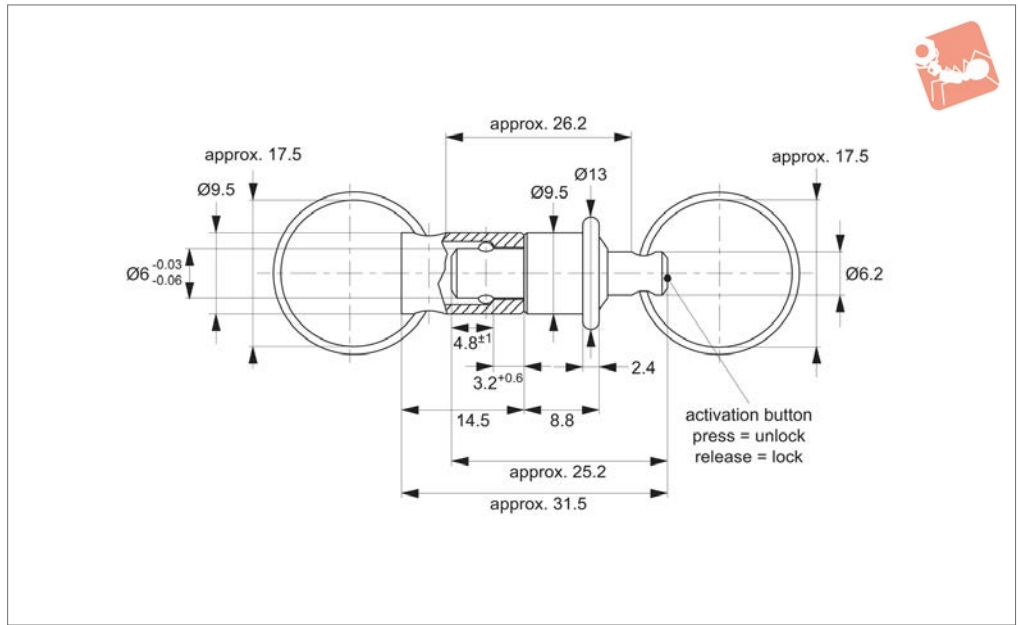

Material

Pin & Bush: stainless steel 1.4305 (AISI 303).
 Ball: stainless steel 1.3541
 Ring & Spring: stainless steel.

Technical Notes

Pressing = unlocking
 Releasing = locking.
 Temperature resistance up to max. 250 °C.

Tips

For lanyards & retaining cables see part no. 33250.

Order No.	Load capacity N max.	Weight g
33178.W0905	30	15



Lanyard - Loop to Loop with split rings - crimps stainless

Ball Lock Pins & Quick Release

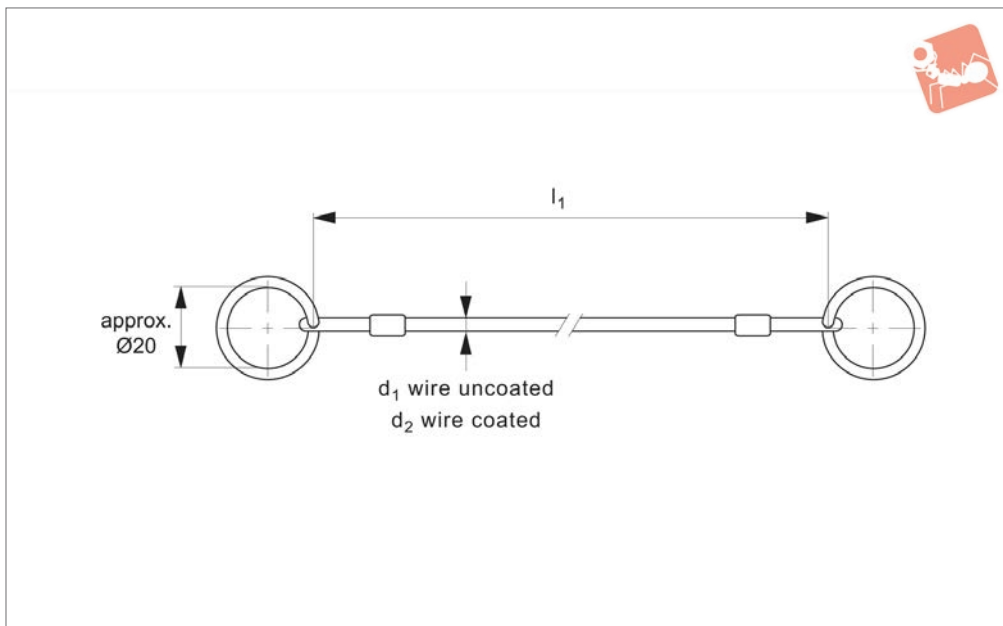

33250

BALL LOCK PINS & QUICK RELEASE PINS

Material

Wire rope: stainless steel
Coating (if present): PA6 see table.
Crimps /sleeves: stainless steel
Split rings: stainless steel

Technical Notes

Crimps tested to failure at 28 Kgf. Tempe-

perature range: up to 250°C (uncoated)

Tips

For use in securing components to assemblies, or to avoid items being misplaced. For our wide range of quick release pins nos. 33060 through 33226.

Order No.	Coating	d ₁ wire uncoated	l ₁	d ₂ wire coated	Weight g
33250.W0940	Black	1.5	150	2.2	6.5
33250.W0941	Black	1.5	200	2.2	6.4
33250.W0943	Black	1.5	300	2.2	7.5
33250.W0950	Clear	1.5	150	2.2	6.5
33250.W0952	Clear	1.5	200	2.2	6.4
33250.W0956	Clear	1.5	300	2.2	7.5
33250.W0930	Uncoated	1.5	150	-	6.5
33250.W0931	Uncoated	1.5	200	-	6.4
33250.W0933	Uncoated	1.5	300	-	7.5

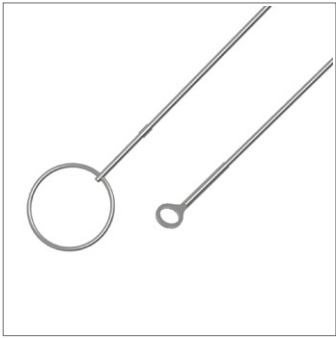

33251

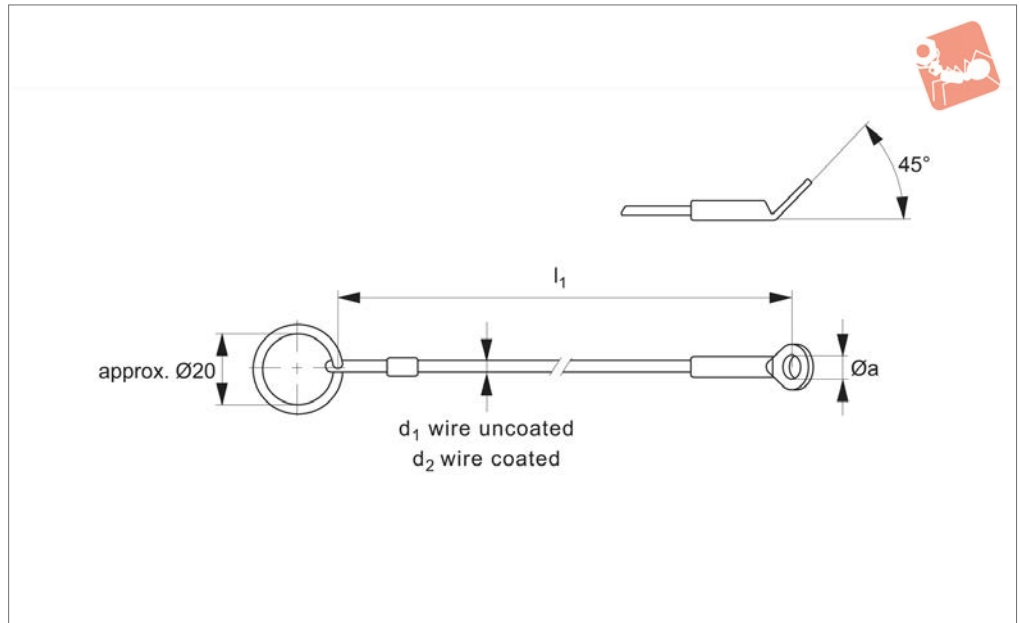

Material

Wire rope: stainless steel.
 Coating (if present): PA6, see table.
 Crimps /sleeves: stainless steel.
 Eyelet and split ring: stainless steel.

temperature range: up to 250°C (uncoated).

Tips

For use in securing components to assemblies, or to avoid items being misplaced. For our wide range of quick release pins nos. 33060 through 33226.

Technical Notes

Crimps tested for failure at 28 Kgf. Tempe-

Order No.	Coating	d ₁ wire uncoated	l ₁	Ø a	d ₂ wire uncoated	Weight g
33251.W0945	Black	1.5	150	4.8	2.0	6.9
33251.W0946	Black	1.5	200	4.8	2.0	7.6
33251.W0948	Black	1.5	300	4.8	2.0	8.6
33251.W0960	Clear	1.5	150	4.8	2.0	6.9
33251.W0962	Clear	1.5	200	4.8	2.0	7.6
33251.W0966	Clear	1.5	300	4.8	2.0	8.6
33251.W0935	Uncoated	1.5	150	4.8	2.0	6.9
33251.W0936	Uncoated	1.5	200	4.8	2.0	7.6
33251.W0938	Uncoated	1.5	300	4.8	2.0	8.6



Lanyard - Split Ring to Rectangle Tab

crimps brass, tab stainless steel

Ball Lock Pins & Quick Release

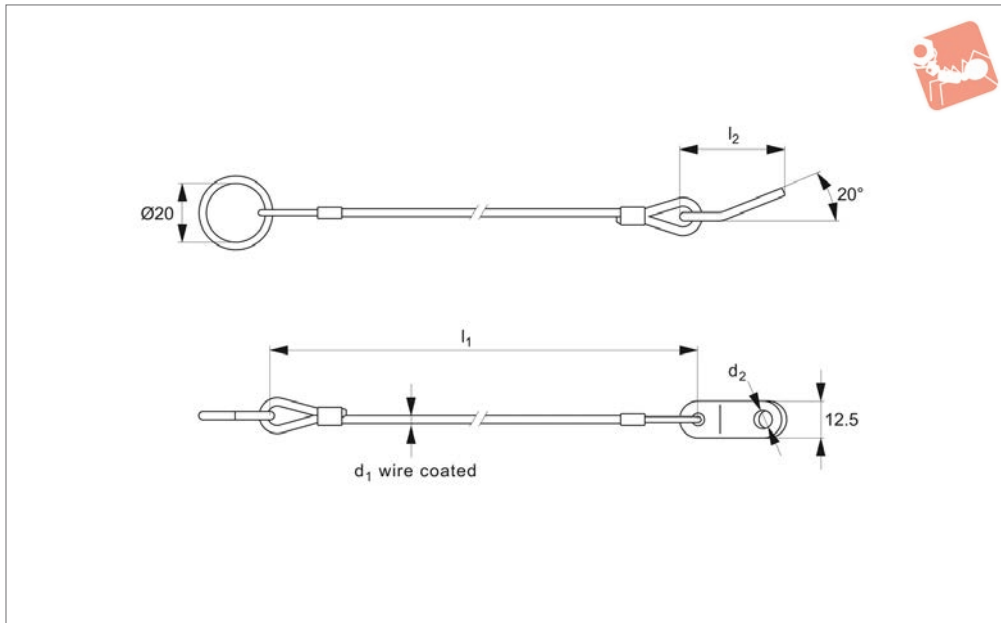

33252

BALL LOCK PINS & QUICK RELEASE PINS

Material

Wire rope: stainless steel.
 Coating: thermoplastic, PVC, green transparent
 Crimps: brass, zinc plated.
 Tabs: stainless steel
 Split ring: stainless steel.

Technical Notes

Temperature range up to 80°C.

Tips

For use in securing components to assemblies, or to avoid items being misplaced. For our wide range of quick release pins

nos.33060 through 33226.

Important Notes

Conform to military spec MIL-DTL-83420 specification

Order No.	Coating	d ₁ wire coated	l ₁	d ₂	l ₂	Weight g
33252.W1301	Green	2.4	150	294.9	29	13
33252.W1302	Green	2.4	200	4.9	29	14
33252.W1303	Green	2.4	300	4.9	29	16



BALL LOCK PINS & QUICK RELEASE PINS



33253

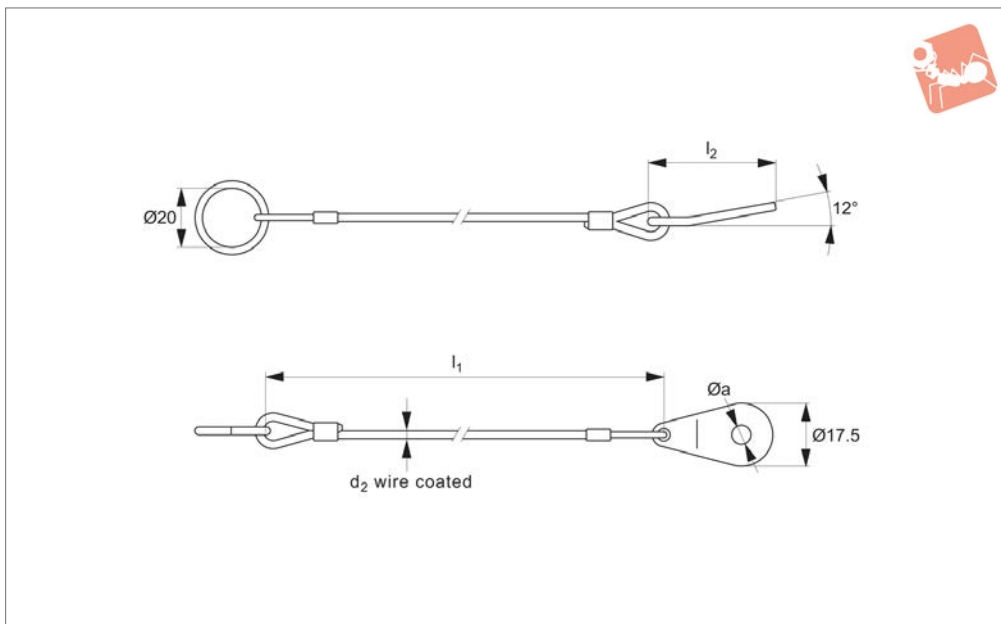

Material

Wire rope: stainless steel.
 Coating: thermoplastic, PVC, green transparent
 Crimps: brass, zinc plated.
 Tabs: stainless steel
 Split ring: stainless steel.

Technical Notes

Temperature range up to 80°C.

Tips

For use in securing components to assemblies, or to avoid items being misplaced. For our wide range of quick release pins

nos.33060 through 33226.

Important Notes

Conform to military spec MIL-DTL-83420 specification

Order No.	Coating	l_1	$\varnothing a$	d_2 wire coated	l_2	Weight g
33253.W1311	Green	150	4.9	2.4	33	13.0
33253.W1312	Green	200	4.9	2.4	33	14.0
33253.W1313	Green	300	4.9	2.4	33	16.0



Lanyard - Cable Tie Loop

thermoplastic

Ball Lock Pins & Quick Release

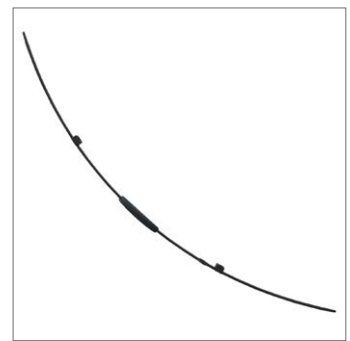
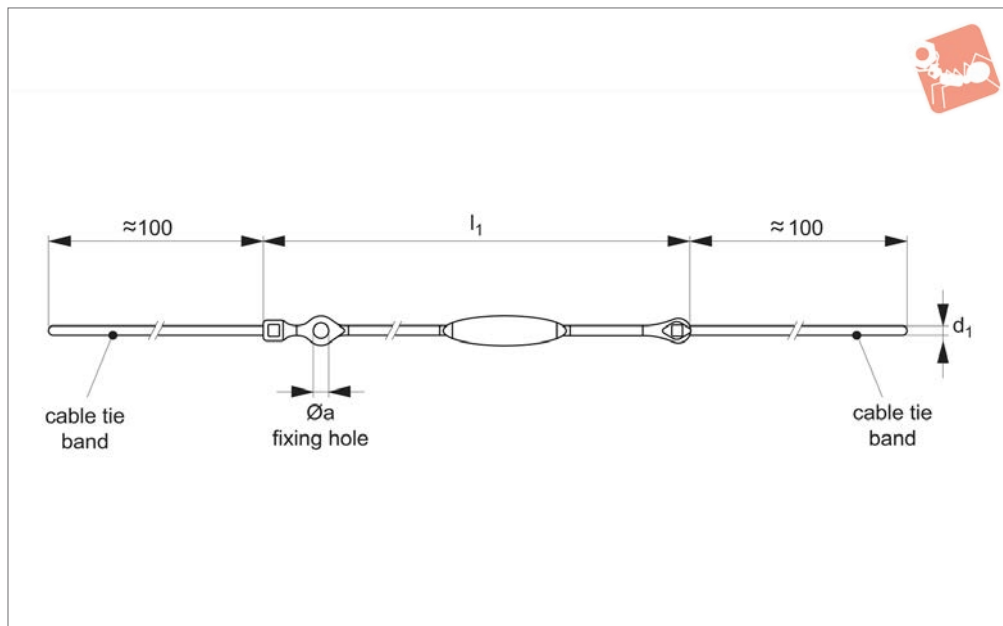

33260

BALL LOCK PINS & QUICK RELEASE PINS

Material

Thermoplastic PA6, grey.

Technical Notes

Temperature range up to 80°C offers two

fixing alternatives:

- Cable tie at both ends
- Cable tie one end and fixing hole at other to secure with M4 screw.

Tips

For use in securing components to assemblies, or to avoid items being misplaced.

Order No.	Coating	d ₁	l ₁	Ø a	Weight g
33260.W0970	n/a	2.5	150	4.2	2.1
33260.W0974	n/a	2.5	250	4.2	2.7



BALL LOCK PINS & QUICK RELEASE PINS



33261

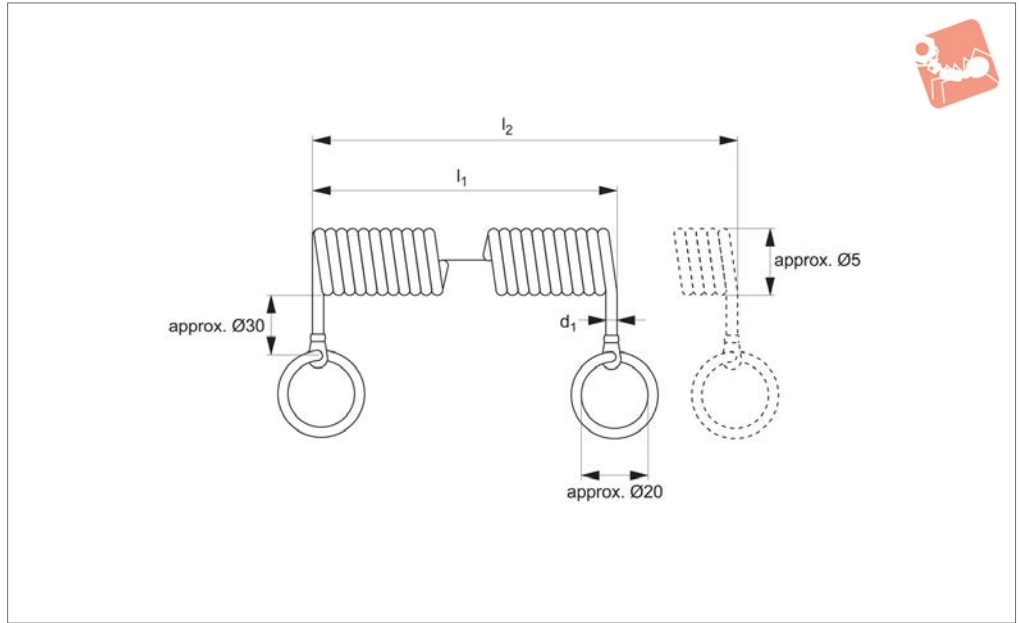

Material

Wire rope: steel.
Coating: PUR, thermoplastic.
Eyelet: brass, zinc plated.
Split ring: stainless steel.

Technical Notes

Temperature range up to 80°C. Coiled

sprung wire offers high extended length in a compact design.

Tips

For use in securing components to assemblies, or to avoid items being misplaced. For our wide range of quick release pins, part nos. 33060 to 33226.

Order No.	PUR coating	d ₁	l ₁ retracted	l ₂ extended	Weight g
33261.W0980	Black	1.5	100	600	11.5
33261.W0982	Black	1.5	200	1200	17.4



Lanyard - Circlip End to Eyelet

crimps brass, tabs stainless steel

Ball Lock Pins & Quick Release

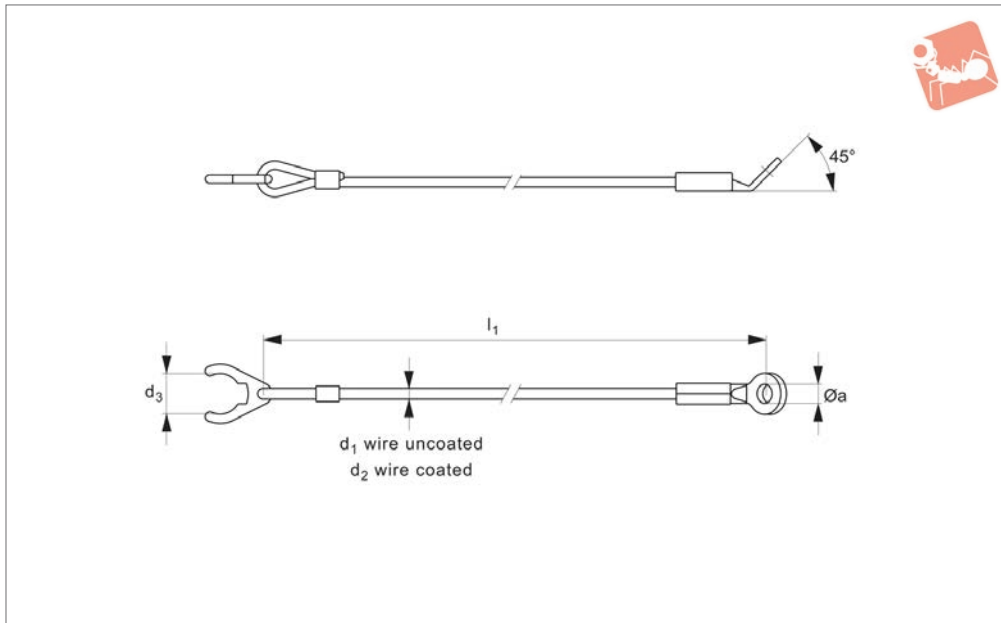

33265

BALL LOCK PINS & QUICK RELEASE PINS

Material

Wire rope: stainless steel.
 Coating (if present): PVC, see table.
 Crimps/sleeves: brass.
 Eyelet, circlip end and split ring: stainless

steel.

Technical Notes

Designed specifically to hold ball lock pin 33194.

Important Notes

Assemble by attaching holding clips to the ball lock pin with a soft-face mallet, disassemble via levering off with a screw driver.

Order No.	Coating	d ₁ wire uncoated	l ₁	Ø a	d ₂ wire coated	d ₅ for use with part no. 33914 of pin dia d ₁	Weight g
33265.W1001	Clear	1.5	150	4.8	2.0	5/ 6	6.0
33265.W1021	Clear	1.5	200	4.8	2.0	5/ 6	7.0
33265.W1041	Clear	1.5	300	4.8	2.0	5/ 6	8.0
33265.W1061	Clear	1.5	150	2.0	4.8	8/10	7.0
33265.W1002	Clear	1.5	200	4.8	2.0	8/10	8.0
33265.W1022	Clear	1.5	200	4.8	2.0	8/10	9.0
33265.W1042	Clear	1.5	150	4.8	2.0	12/16	8.0
33265.W1062	Clear	1.5	200	4.8	2.0	12/16	9.0
33265.W1003	Clear	1.5	300	4.8	2.0	12/16	10.0
33265.W1023	Clear	1.5	150	4.8	2.0	20/25	12.0
33265.W1043	Clear	1.5	200	4.8	2.0	20/25	13.0
33265.W1063	Clear	1.5	300	4.8	2.0	20/25	14.0
33265.W1101	Black	1.5	150	4.8	2.0	5/ 6	6.0
33265.W1121	Black	1.5	200	4.8	2.0	5/ 6	7.0
33265.W1141	Black	1.5	300	4.8	2.0	5/ 6	8.0
33265.W1161	Black	1.5	150	4.8	2.0	8/10	7.0
33265.W1102	Black	1.5	200	4.8	2.0	8/10	8.0
33265.W1122	Black	1.5	300	4.8	2.0	8/10	9.0
33265.W1142	Black	1.5	150	4.8	2.0	12/16	8.0
33265.W1162	Black	1.5	200	4.8	2.0	12/16	9.0
33265.W1103	Black	1.5	300	4.8	2.0	12/16	10.0
33265.W1123	Black	1.5	150	4.8	2.0	20/25	12.0
33265.W1143	Black	1.5	200	4.8	2.0	20/25	13.0
33265.W1163	Black	1.5	300	4.8	2.0	20/25	14.0
33265.W1201	Uncoated	1.5	150	4.8	-	5/ 6	6.0
33265.W1221	Uncoated	1.5	200	4.8	-	5/ 6	7.0
33265.W1241	Uncoated	1.5	300	4.8	-	5/ 6	8.0
33265.W1261	Uncoated	1.5	150	4.8	-	8/10	7.0
33265.W1202	Uncoated	1.5	200	4.8	-	8/10	8.0
33265.W1222	Uncoated	1.5	300	4.8	-	8/10	9.0
33265.W1242	Uncoated	1.5	200	4.8	-	12/16	8.0
33265.W1262	Uncoated	1.5	200	4.8	-	12/16	9.0
33265.W1203	Uncoated	1.5	300	4.8	-	12/16	10.0

Ball Lock Pins & Quick Release



Lanyard - Circlip End to Eyelet

crimps brass, tabs stainless steel



Order No.	Coating	d ₁ wire uncoated	l ₁	Ø a	d ₂ wire coated	d ₅ for use with part no. 33914 of pin dia d ₁	Weight g
33265.W1223	Uncoated	1.5	150	4.8	-	20/25	12.0
33265.W1243	Uncoated	1.5	200	4.8	-	20/25	13.0
33265.W1263	Uncoated	1.5	300	4.8	-	20/25	14.0

BALL LOCK PINS & QUICK RELEASE PINS



Lanyard - Circlip End to Loop with crimps brass, tabs stainless steel, for ball lock pins

Ball Lock Pins & Quick Release

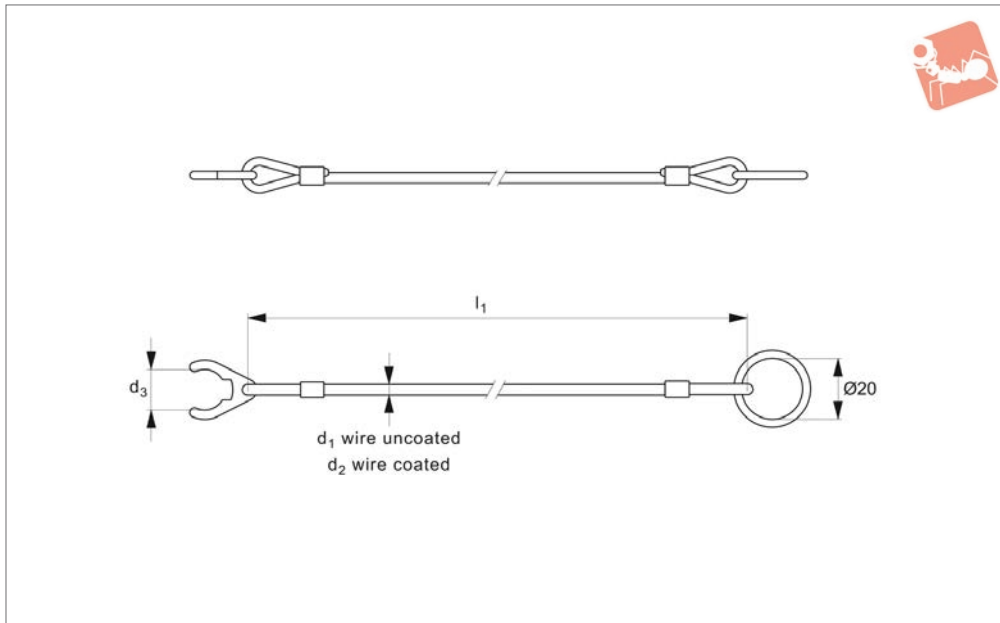

33266

BALL LOCK PINS & QUICK RELEASE PINS

Material

Wire rope: stainless steel.
Coating (if present): PA6, see table.
Crimps/sleeves: brass.
Circlip end and split ring: stainless steel.

Technical Notes

Designed specifically to hold ball lock pin 33194.

Important Notes

Assemble by attaching holding clips to the ball lock pin with a soft-face mallet, disassemble via levering off with a screw driver.

Order No.	Coating	d_1 wire uncoated	l_1	d_2 wire coated	d_3 for use with part no. 33914 of pin dia d_1	Weight g
33266.W1011	Clear	1.5	150	2.0	5/6	6.3
33266.W1031	Clear	1.5	150	2.0	8/10	7.2
33266.W1051	Clear	1.5	150	2.0	12/16	8.4
33266.W1071	Clear	1.5	150	2.0	20/25	11
33266.W1012	Clear	1.5	200	2.0	5/6	6.9
33266.W1032	Clear	1.5	200	2.0	8/10	7.8
33266.W1052	Clear	1.5	200	2.0	12/16	9.0
33266.W1072	Clear	1.5	200	2.0	20/25	12
33266.W1013	Clear	1.5	300	2.0	5/6	8.2
33266.W1033	Clear	1.5	300	2.0	8/10	9.0
33266.W1053	Clear	1.5	300	2.0	12/16	10
33266.W1073	Clear	1.5	300	2.0	20/25	13
33266.W1111	Black	1.5	150	2.0	5/6	6.3
33266.W1131	Black	1.5	150	2.0	8/10	7.3
33266.W1151	Black	1.5	150	2.0	12/16	8.4
33266.W1171	Black	1.5	150	2.0	20/25	11
33266.W1112	Black	1.5	200	2.0	5/6	7.0
33266.W1132	Black	1.5	200	2.0	8/10	7.8
33266.W1152	Black	1.5	200	2.0	12/16	9.0
33266.W1172	Black	1.5	200	2.0	20/25	12
33266.W1113	Black	1.5	300	2.0	5/6	8.2
33266.W1133	Black	1.5	300	2.0	8/10	9.0
33266.W1153	Black	1.5	300	2.0	12/16	10
33266.W1173	Black	1.5	300	2.0	20/25	13
33266.W1211	Uncoated	1.5	150	-	5/6	5.9
33266.W1231	Uncoated	1.5	150	-	8/10	6.8
33266.W1251	Uncoated	1.5	150	-	12/16	8.0
33266.W1271	Uncoated	1.5	150	-	20/25	11
33266.W1212	Uncoated	1.5	200	-	5/6	6.4
33266.W1232	Uncoated	1.5	200	-	8/10	7.3
33266.W1252	Uncoated	1.5	200	-	12/16	8.5
33266.W1272	Uncoated	1.5	200	-	20/25	12
33266.W1213	Uncoated	1.5	300	-	5/6	7.4

Ball Lock Pins & Quick Release



Lanyard - Circlip End to Loop with crimps brass, tabs stainless steel, for ball lock pins



Order No.	Coating	d ₁ wire uncoated	l ₁	d ₂ wire coated	d ₃ for use with part no. 33914 of pin dia d ₁	Weight g
33266.W1233	Uncoated	1.5	300	-	8/10	8.6
33266.W1253	Uncoated	1.5	300	-	12/16	9.5
33266.W1273	Uncoated	1.5	300	-	20/25	13

BALL LOCK PINS & QUICK RELEASE PINS



Retaining Cable with holding clip for no. 33331

Ball Lock Pins & Quick Release

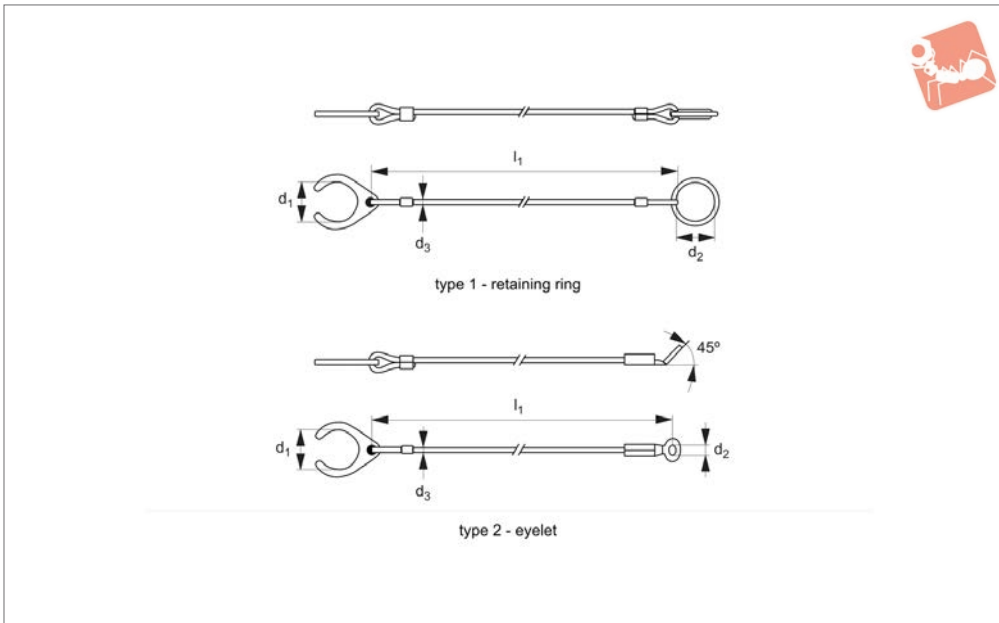

33268

BALL LOCK PINS & QUICK RELEASE PINS

Material

Split ring or eyelet: stainless steel.
Holding circlip: thermoplastic PA 6, black.
Wire rope: stainless steel.

Coating: thermoplastic PA 6, black.

Technical Notes

Retaining cables designed specifically for

use with threaded lock pin no. 33331.
Lanyard prevents accidental loss of pin
from application.

Order No.	Type	d ₁	l ₁	d ₂	d ₃ wire coated	To suit lock pin 33331	Weight g
33268.W6001	1	20.3	150	20.3	2	M 8 to M16	6
33268.W6002	1	20.3	200	20.3	2	M 8 to M16	7
33268.W6003	1	20.3	300	20.3	2	M 8 to M16	8
33268.W6011	2	20.3	150	4.8	2	M 8 to M16	6
33268.W6012	2	20.3	200	4.8	2	M 8 to M16	7
33268.W6013	2	20.3	300	4.8	2	M 8 to M16	8

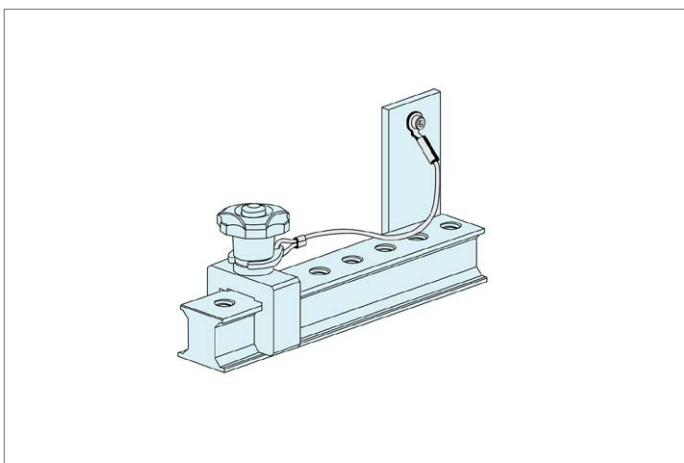



33270

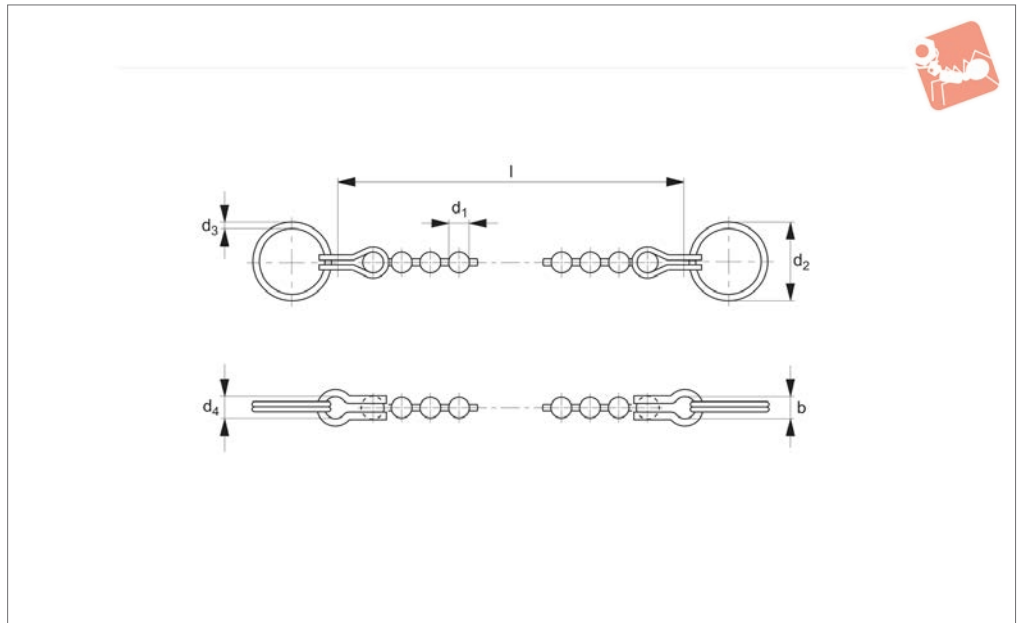

Material

Bead chain: stainless steel AISI 304, polished.
End attachments: brass, nickel plated.

Split rings: stainless steel.

Technical Notes

Retaining chains secure single-acting ball

lock pins against possible loss.

Other chain lengths available on request.

Order No.	Length l	d ₁	Breaking strength kg min.	d ₄	b	Ring thickness d ₃	Ring dia. d ₂
33270.W0200	200	3.2	20	3.5	6	1.52	24
33270.W0350	350	3.2	20	3.5	6	1.52	24
33270.W0500	500	3.2	20	3.5	6	1.52	24

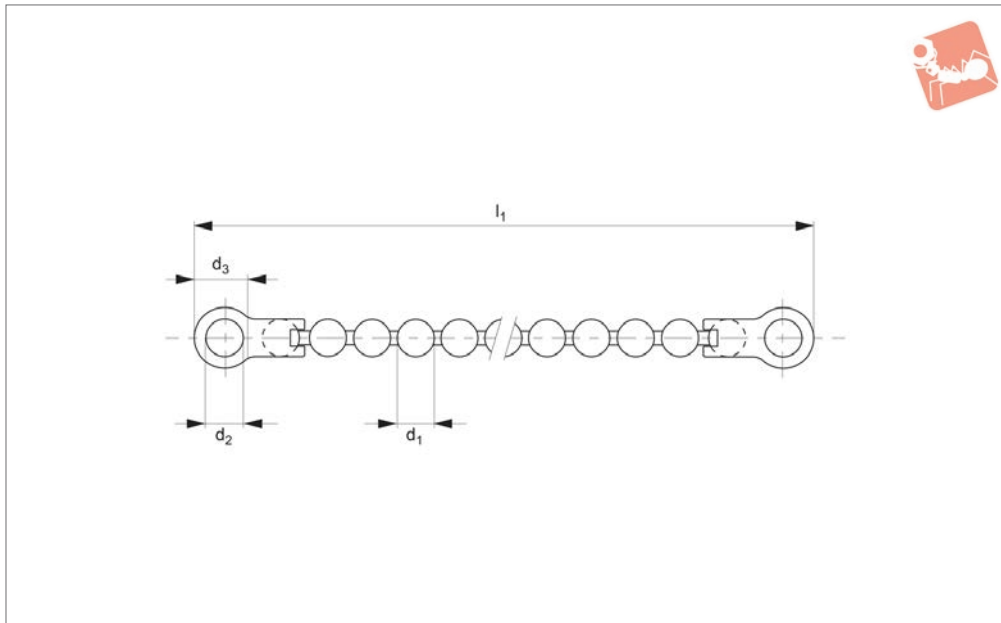

33272

BALL LOCK PINS & QUICK RELEASE PINS

Material

Bead chain: stainless steel AISI 304.
Terminals: brass.

Tips

For use in securing components to assemb-

lies, or to avoid items being misplaced. For a wide range of detent pins and quick release ball lock pins see parts 33010 through 33226. Terminals also available in AISI 304 stainless steel on request. Subject

to min. quantity.

Order No.	Trade size	d ₁	l ₁ nom.	d ₂	d ₃	Terminal material
33272.W0080	10	4.5	80	4.7	6.35	Brass
33272.W0100	10	4.5	100	4.7	6.35	Brass
33272.W0150	10	4.5	150	4.7	6.35	Brass
33272.W0200	10	4.5	200	4.7	6.35	Brass
33272.W0300	10	4.5	300	4.7	6.35	Brass
33272.W0450	10	4.5	450	4.7	6.35	Brass



BALL LOCK PINS & QUICK RELEASE PINS



33274

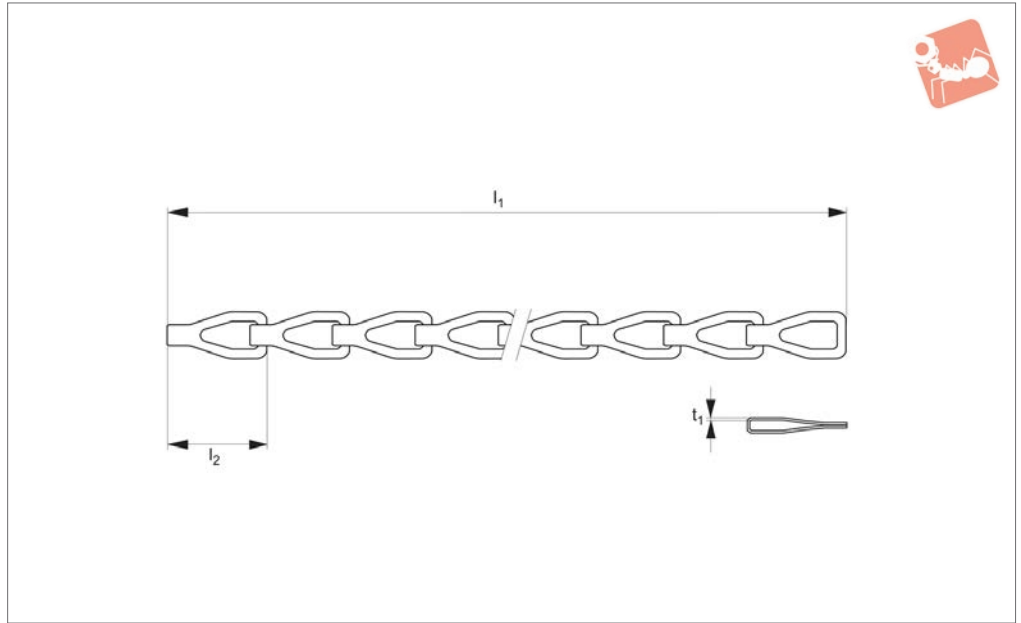

Material

Brass.

Tips

For use in securing components to assemb-

lies, or to avoid items being misplaced. For a wide range of detent pins and quick release ball lock pins see parts 33010 through 33226.

Order No.	Material	Trade size	l_1 nom.	l_2	t_1
33274.W0100	Brass	8	100	25	0.95
33274.W0150	Brass	8	150	25	0.95
33274.W0200	Brass	8	200	25	0.95
33274.W0300	Brass	8	300	25	0.95
33274.W0450	Brass	8	450	25	0.95

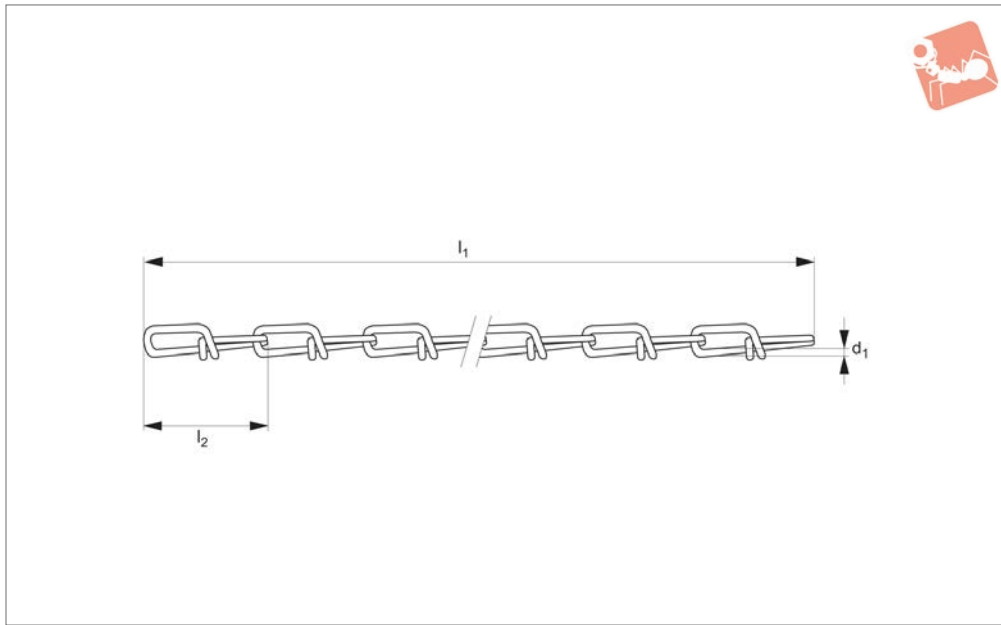

33276

BALL LOCK PINS & QUICK RELEASE PINS

Material

Steel (1008), zinc plated.

Tips

For use in securing components to assemb-

lies, or to avoid items being misplaced. For a wide range of detent pins and quick release ball lock pins see parts 33010 through 33226. Terminals also available in

AISI 304 stainless steel on request. Subject to min. quantity.

Order No.	Material	Trade size	d ₁	l ₁ nom.	l ₂
33276.W0128	Steel	4	1.8	128	32
33276.W0192	Steel	4	1.8	192	32
33276.W0256	Steel	4	1.8	256	32
33276.W0320	Steel	4	1.8	320	32
33276.W0448	Steel	4	1.8	448	32



BALL LOCK PINS & QUICK RELEASE PINS



33246

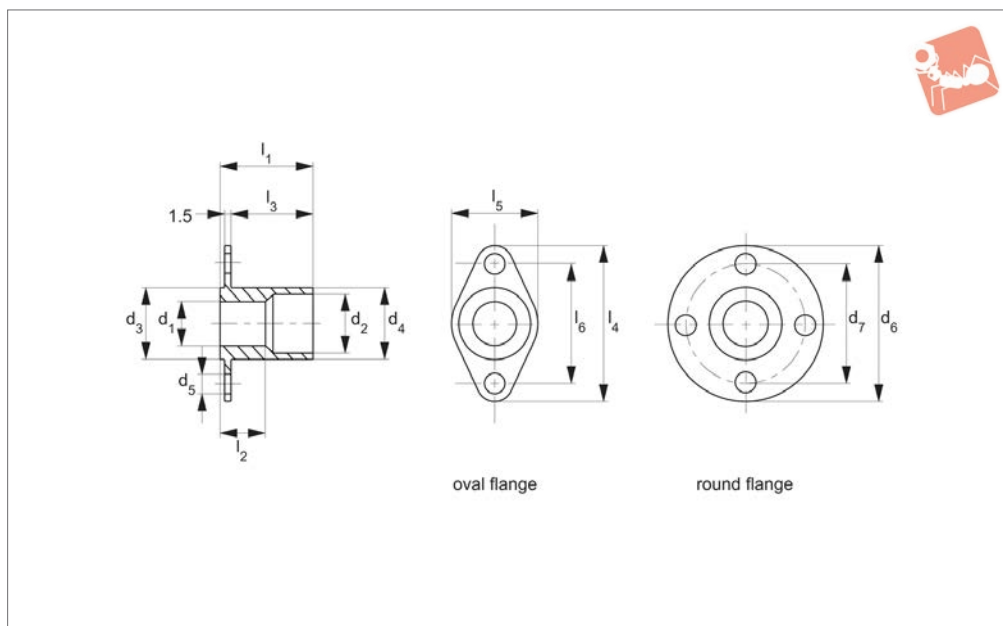

Material

Body: stainless steel 1.4305. (AISI 303).

Technical Notes

For quick and safe location of single acting ball lock pins - especially in soft materials

such as aluminium, or in thin walled components.

Can be used from both sides. Optimised centering due to precision collar on bush.

Tips

For use with our wide range of metric ball lock pins, see part no.'s 33060 through to 33226.

Order No.	Type	For pin dia. nom.	d ₁ tol. H11	d ₂	d ₃ -0.05	d ₄ -0.1	d ₅	d ₆	d ₇	l ₁	l ₂	l ₃	l ₄	l ₅	l ₆	Weight g
33246.W0305	Oval flange	5	5	8	10	9.9	3.4	-	-	12	5.4	9.5	25	15	19	6
33246.W0306	Oval flange	6	6	8	10	9.9	3.4	-	-	13	5.3	10.5	25	15	19	6
33246.W0308	Oval flange	8	8	10	12	11.9	4.5	-	-	19	10.3	16.5	30	18	22	10
33246.W0310	Oval flange	10	10	13	16	15.9	4.5	-	-	21	10.2	18.5	35	20	27	19
33246.W0312	Oval flange	12	12	15	19	18.9	4.5	-	-	27	15.2	24.5	40	24	30	34
33246.W0316	Oval flange	16	16	20	24	23.9	5.5	-	-	30	15.3	27.5	50	30	40	52
33246.W0405	Round flange	5	5	8	10	9.9	3.4	25	19	12	5.4	9.5	-	-	-	9
33246.W0406	Round flange	6	6	8	10	9.9	3.4	25	19	13	5.3	10.5	-	-	-	9
33246.W0408	Round flange	8	8	10	12	11.9	4.5	30	22	19	10.3	16.5	-	-	-	14
33246.W0410	Round flange	10	10	13	16	15.9	4.5	35	27	21	10.2	18.5	-	-	-	24
33246.W0412	Round flange	12	12	15	19	18.9	4.5	40	30	27	15.2	24.5	-	-	-	41
33246.W0416	Round flange	16	16	20	24	23.9	5.5	50	40	30	15.3	27.5	-	-	-	63



Locating Bushes for ball lock pins

Ball Lock Pins & Quick Release

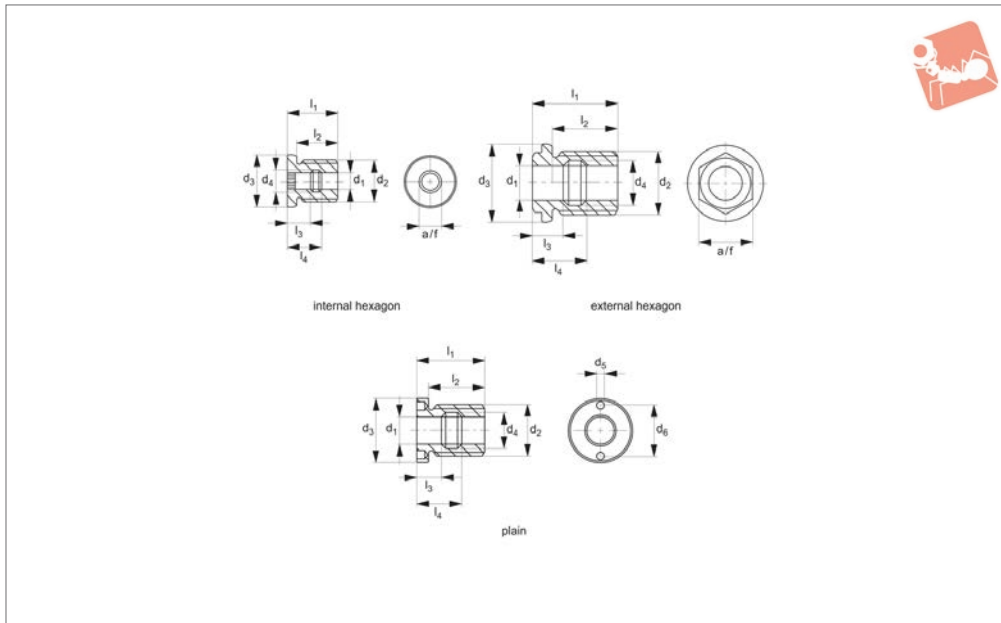

33248

BALL LOCK PINS & QUICK RELEASE PINS

Material

Body: stainless steel 1.4305. (AISI 303).

Technical Notes

For quick and safe location of single acting ball lock pins - especially in soft materials such as aluminium, or in thin walled

components.

Can be used from both sides. Optimised centering due to precision collar on bush.

Important Notes

l_5 and l_6 refer to depths of ball locating recess when bush is installed flange collar

up, or flange collar inverted (see diagram below).

Use pin face spanner with 5mm pin to install pin mount bushings.

Order No.	Type	d_1 tol. H11	d_2	d_3 tol. h9	d_4	d_5	d_6	Weight g
33248.W0905	Int Hex	5	M12	18	6.0	-	-	15
33248.W0906	Int Hex	6	M12	18	7.5	-	-	13
33248.W0908	Int Hex	8	M16	22	10.0	-	-	29
33248.W0910	Int Hex	10	M24	30	12.5	-	-	75
33248.W0912	Int Hex	12	M24	30	15.0	-	-	66
33248.W0916	Ext Hex	16	M30	36	19.5	-	-	124
33248.W0920	Ext Hex	20	M36	45	25.5	-	-	208
33248.W0924	Ext Hex	25	M42	50	32.0	-	-	415
33248.W0925	Plain	16	M30	39	19.5	5.1	30	160
33248.W0926	Plain	20	M36	43	25.5	5.1	30	257
33248.W0927	Plain	25	M42	50	32.0	5.1	36	434

Order No.	l_1	l_2	l_3	l_4	l_5	l_6	A/F
33248.W0905	19	15	9.0	13.0	5.1	9.0	5
33248.W0906	19	15	9.4	13.0	5.6	8.8	6
33248.W0908	25	20	12.0	17.0	7.3	11.7	8
33248.W0910	29	24	13.5	19.5	8.9	14.1	10
33248.W0912	29	24	14	20	9.6	14.4	12
33248.W0916	39	29	15.5	23.5	6.1	12.8	24
33248.W0920	49	38	17.5	31.5	7.7	19.3	30
33248.W0924	65	50	26.5	38.5	13.3	21.8	36
33248.W0925	39	33	15.5	23.5	10.4	16.6	-
33248.W0926	49	42	17.5	31.5	11.9	23.1	-
33248.W0927	65	57	26.5	38.5	13.3	21.8	-





One-Touch Fastener - Ball Locking

push button lock - recessed button - steel



One Touch Fasteners

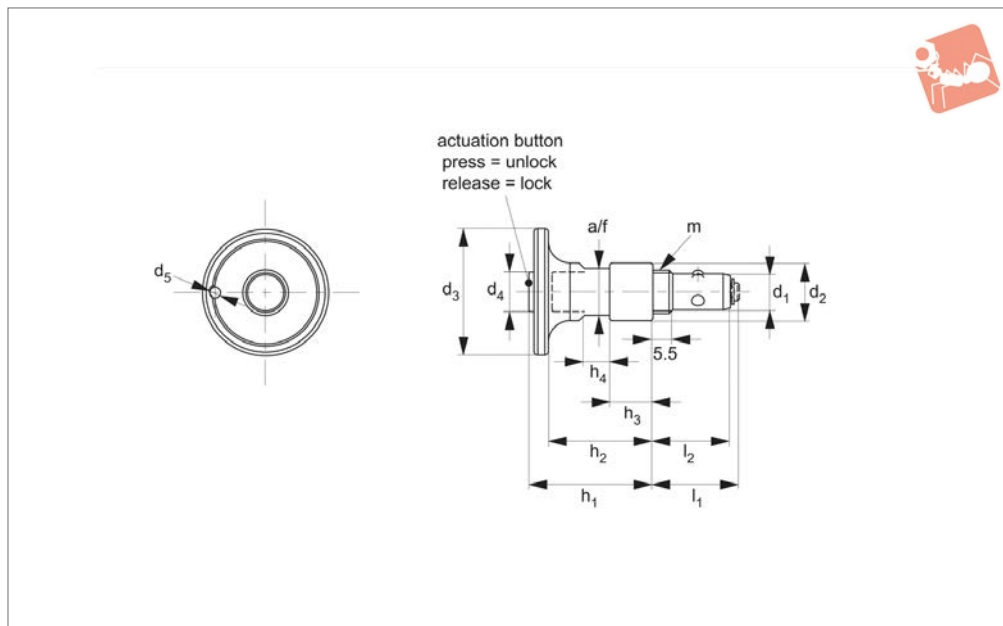

33910

ONE TOUCH FASTENERS

Material

Body & button: steel, nickel plated.
 Ball: stainless steel.
 Coil ring: stainless steel.
 O-Ring: fluororubber.

Technical Notes

One-touch fasteners are the ideal solution for applications requiring rapid and recurring change over of tooling or set ups. Use in applications as diverse as bottling processes, machine covers, changing of cogs and drive belts. One-touch fasteners

provide a quick, simple and secure change over solution - no time waste in unfastening screws or other permanent fixings, and no opportunity for lost fixings in your machinery.
 Temperature resistant to 180°C.

Tips

Secure one-touch fasteners to your assembly with lanyards and retaining cables, see part no. 33250.

Important Notes

Suitable for panels/enclosures of 6 to 10mm thickness. For locating bushes see part no. 33920.
 Recessed button handle means button is not exposed to accidental activation for added security.

Actuation:
 push button: unlock (to pass pin through panels)
 release button: lock to securely fasten.

Order No.	For single panel thickness	d_1 -0.05 -0.10	d_2	d_3	d_4	d_5	h_1	h_2	Weight g
33910.W1006	6-10	6	12	25	8	-	22.0	18	30
33910.W1610	6-16	10	16	35	11	3	34.5	29	30

Order No.	h_3	h_4	l_1	l_2	m	A/F	Clamping force N	Shear strength N	Tensile strength N
33910.W1006	6	5.5	21.0	19.0	M 8x1,25	10	30	3000	500
33910.W1610	12	7.0	23.5	21.5	M12x1,50	13	50	9000	1500

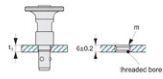

6mm panel thickness
installation via threaded bore

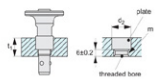

6mm to 13mm panel thickness
installation via recessed hole with
threaded bore



One-Touch Fastener - Ball Locking

push button lock - button handle - stainless steel



One Touch Fasteners

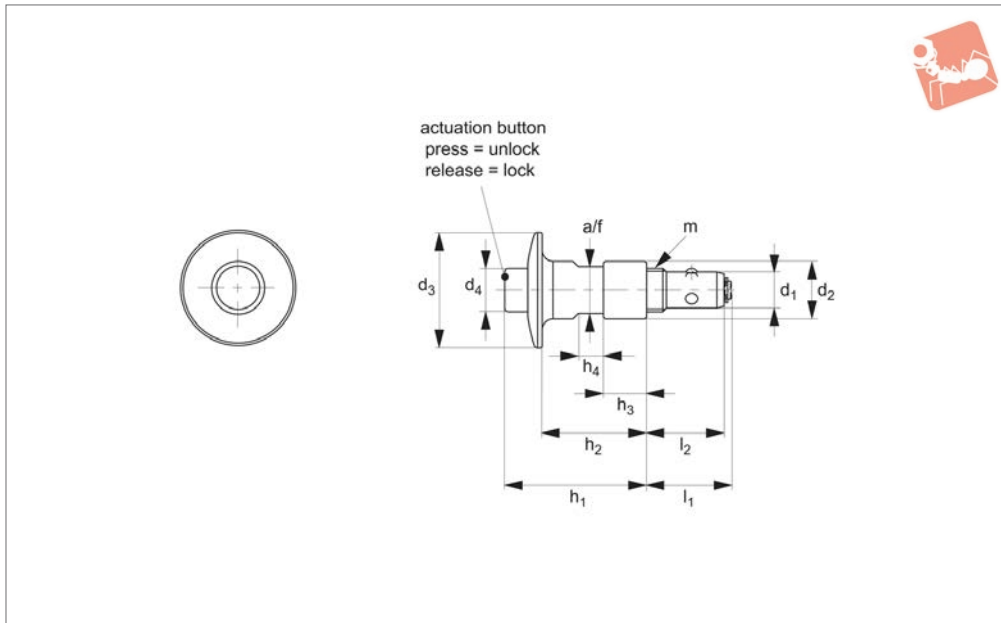

33912

ONE TOUCH FASTENERS

Material

Body: stainless steel.
 Button: stainless steel, nickel plated.
 Ball & coil ring: stainless steel.
 O-Ring: fluororubber.

Technical Notes

One-touch fasteners are the ideal solution for applications requiring rapid and recurring change over of tooling or set ups. Use

in applications as diverse as bottling processes, machine covers, changing of cogs and drive belts. One-touch fasteners provide a quick, simple and secure change over solution - no time waste in unfastening screws or other permanent fixings, and no opportunity for lost fixings in your machinery.
 Temperature resistant to 180°C.

Important Notes

Suitable for panels/enclosures of 6 to 10mm thickness.
 For locating bushes see part no. 33920.

Actuation:
 push button: unlock (to pass pin through panels)
 release button: lock to securely fasten.

Order No.	For single panel thickness	d_1 -0.05 -0.10	d_2	d_3	d_4	h_1	h_2	Weight g
33912.W1006	6-10	6	12	23	8	26.0	18	30
33912.W1610	6-16	10	16	32	12	39.4	29	75

Order No.	h_3	h_4	l_1	l_2	m	A/F	Clamping force N	Shear strength N	Tensile strength N
33912.W1006	6	5.5	21.0	19.0	M 8x1,25	10	30	3000	500
33912.W1610	12	7.0	23.5	21.5	M12x1,50	13	50	9000	1500

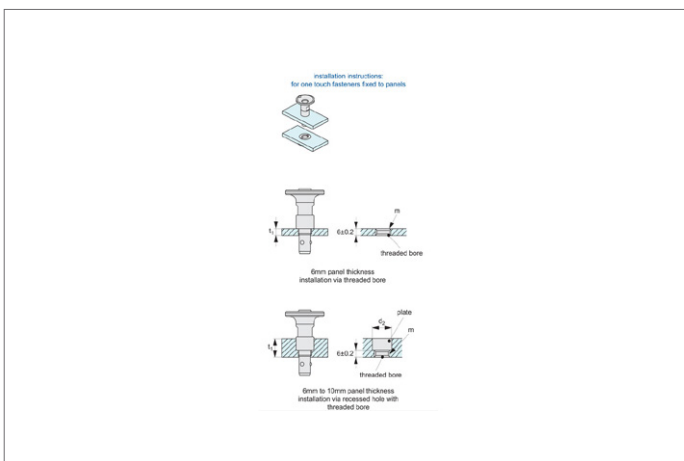



33914

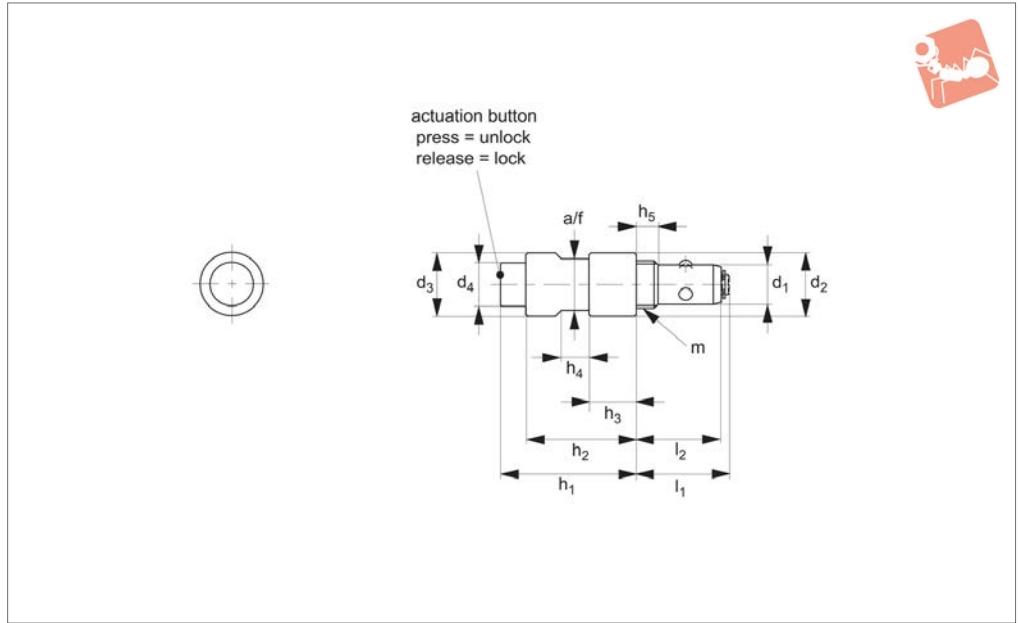

Material

Body & button: steel, nickel plated.
 Ball & coil ring: stainless steel.
 Snap Ring: stainless steel.

Technical Notes

One-touch fasteners are the ideal solution for applications requiring rapid and recurring change over of tooling or set ups. Use in applications as diverse as bottling processes, machine covers, changing of

cogs and drive belts. One-touch fasteners provide a quick, simple and secure change over solution - no time wasted in unfastening screws or other permanent fixings, and no opportunity for lost fixings in your machinery.
 Temperature resistant to 180°C.

Important Notes

Suitable for panels/enclosures of 6 to 16mm thickness.

For locating bushes see part no. 33920.

Actuation:

push button: unlock (to pass pin through panels)
 release button: lock to securely fasten.

Note: One-touch fastener 33914 is not suitable for installation unattached from panel.

Order No.	For single panel thickness		d_1 -0.05 -0.10	d_2	d_3	d_4	h_1	h_2	h_3	Weight g
33914.W1006	6-10		6	12	12	8	22.0	17.5	6	30
33914.W1610	6-16		10	16	16	11	34.4	28.0	12	50

Order No.	h_4	h_5	l_1	l_2	m	A/F	Clamping force N	Shear strength N	Tensile strength N
33914.W1006	5.5	5.5	21.0	19.0	M8x1,25	10	30	3000	500
33914.W1610	7.0	5.5	23.5	21.5	M12x1,5	13	50	9000	1500



One-Touch Fastener - Ball Locking

push button lock - straight - steel



One Touch Fasteners

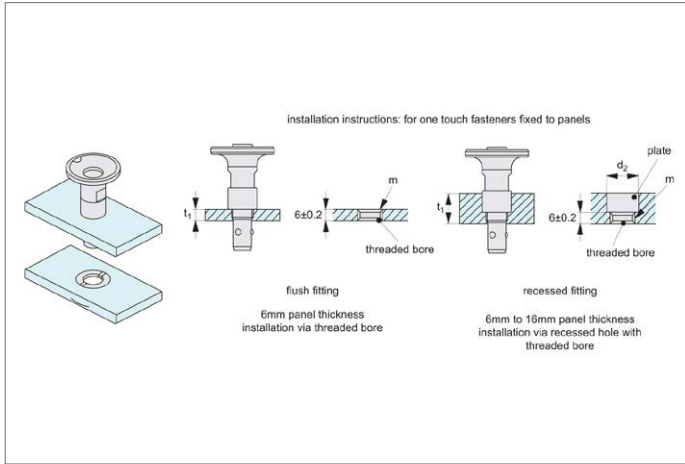



33915

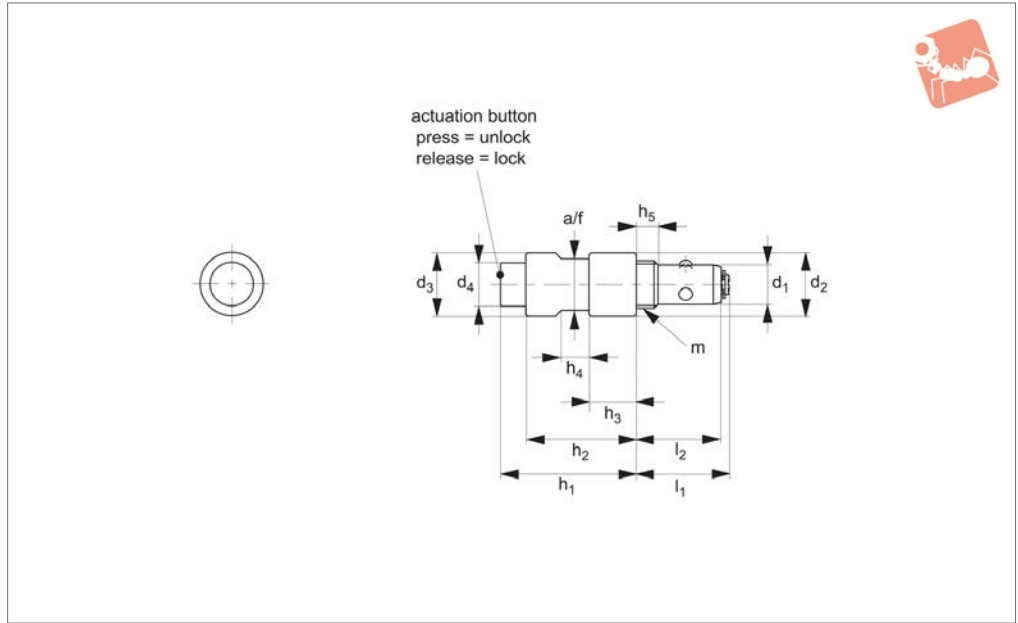

Material

Body & button: stainless steel
 Ball & coil ring: stainless steel.
 Snap Ring: stainless steel.

Technical Notes

One-touch fasteners are the ideal solution for applications requiring rapid and recurring change over of tooling or set ups. Use in applications as diverse as bottling processes, machine covers, changing of

cogs and drive belts. One-touch fasteners provide a quick, simple and secure change over solution - no time wasted in unfastening screws or other permanent fixings, and no opportunity for lost fixings in your machinery.
 Temperature resistant to 180°C.

Important Notes

Suitable for panels/enclosures of 6 to 16mm thickness.

For locating bushes see part no. 33920.

Actuation:

push button: unlock (to pass pin through panels)
 release button: lock to securely fasten.

Note: One-touch fastener 33915 is not suitable for installation unattached from panel.

Order No.	For single panel thickness		d_1 -0.05 -0.10	d_2	d_3	d_4	h_1	h_2	h_3	Weight g
33915.W1006	6-10		6	12	25	8	22.0	17.5	6	30
33915.W1610	6-16		10	16	35	11	34.4	28.0	12	50

Order No.	h_4	h_5	l_1	l_2	m	A/F	Clamping force N	Shear strength N	Tensile strength N
33915.W1006	5.5	5.5	21.0	19.0	M 8x1,25	10	30	3000	500
33915.W1610	7.0	5.5	23.5	21.5	M12x1,5	13	50	9000	1500



One-Touch Fastener - Ball Locking

push button lock - straight - stainless steel



One Touch Fasteners

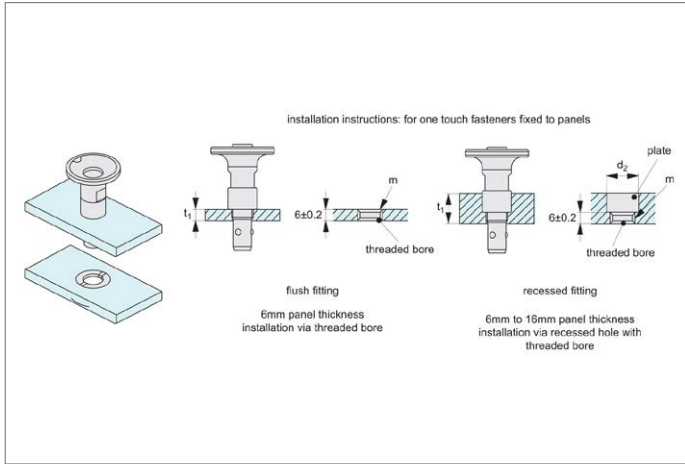



33916

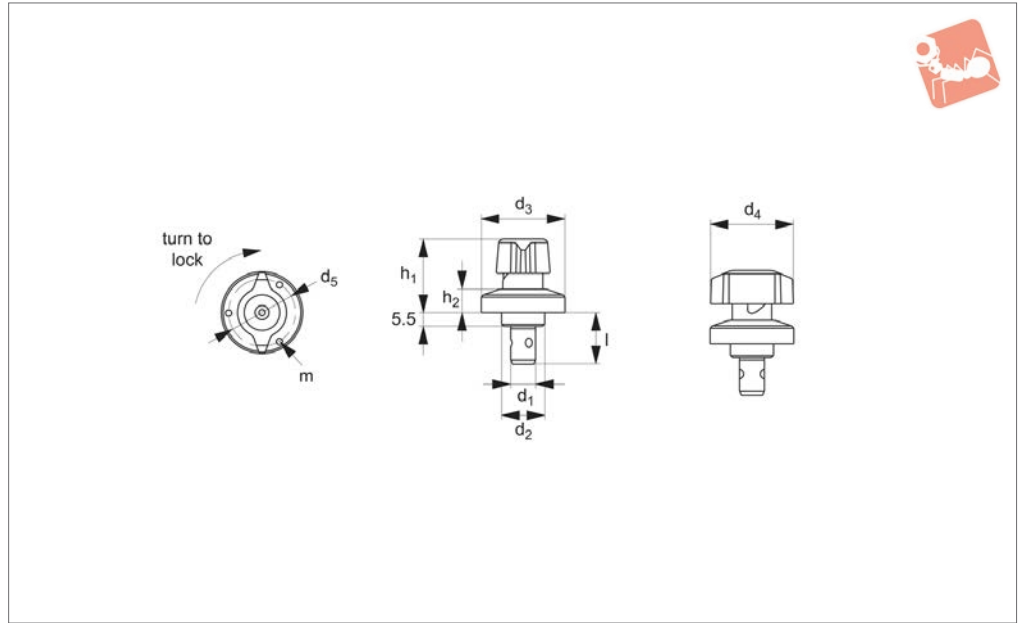

Material

Body & Shank: steel, nickel plated.
 Knob: plastic, black.
 Ball & Spring: Titanium G5.

Technical Notes

One-touch fasteners are the ideal solution for applications requiring rapid and recurring change over of tooling or set ups. Use in applications as diverse as bottling processes, machine covers, changing of cogs and drive belts. One-touch fasteners

provide a quick, simple and secure change over solution - no time wasted in unfastening screws or other permanent fixings, and no opportunity for lost fixings in your machinery.

Important Notes

Suitable for panels/enclosures of 6 to 20mm thickness.
 For locating bushes see part no. 33920.
 Quarter turn handle, easy-to-read on/off position of the one-touch fastener for

increased security.
 Temperature resistant to 180°C.

Actuation:

- Turn handle to off position: locking balls retract and are held in retracted position via notched catch.
- Pass fastener through panel.
- Turn handle 45° to on position: locking balls engage with locating bush, panels are securely fastened.

Order No.	For single panel thickness	d_1 -0.05 -0.10	d_2 tol. h9	d_3	d_4	d_5	h_1	h_2	l	m	Clamping force N	Weight g
33916.W1006	6-10	6	14	25	25	21	24.5	6.5	19.5	M 2x0,4	30	40
33916.W1410	6-14	10	18	34	34	28	31.0	10.0	21.5	M 3x0,5	50	95
33916.W2010	12-20	10	18	34	34	28	31.0	10.0	27.5	M 3x0,5	50	100

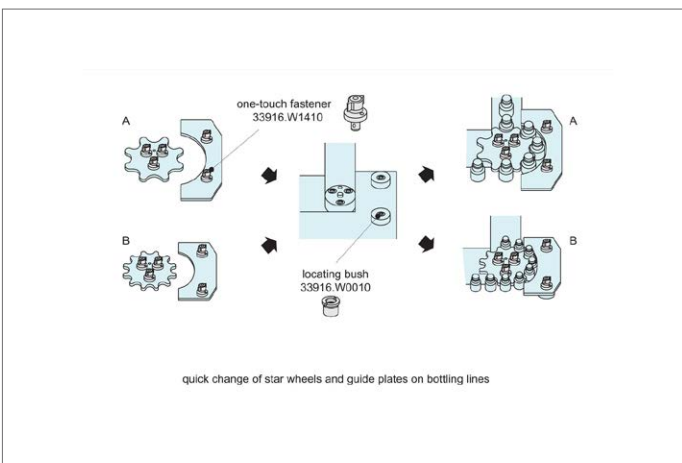



One-Touch Fastener - Ball Locking

quarter turn - installation instructions

33916 - 33918
Positioning Elements

Operating Instructions

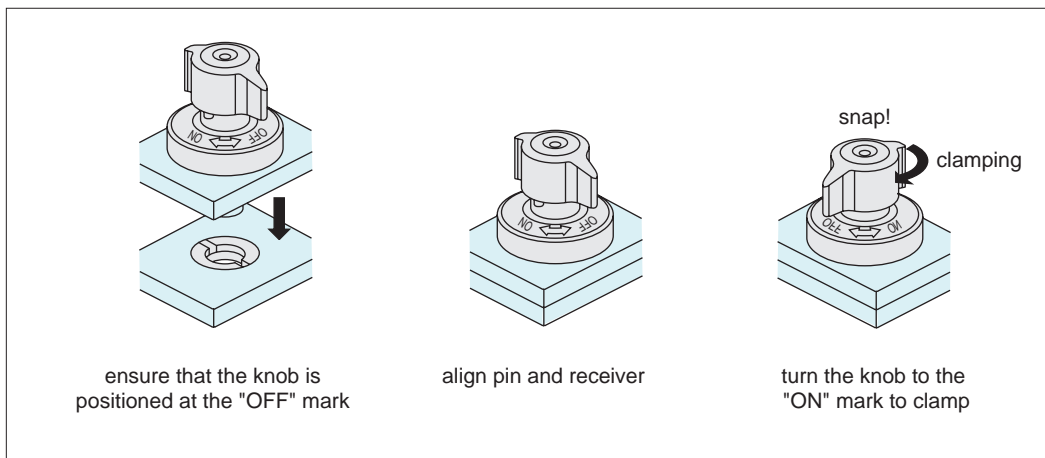

Easy Status Identification

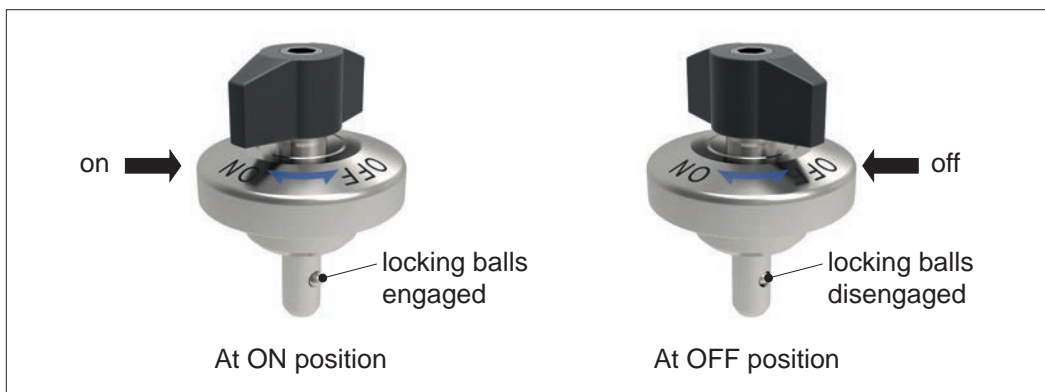

Installation Dimensions for 33916-33918

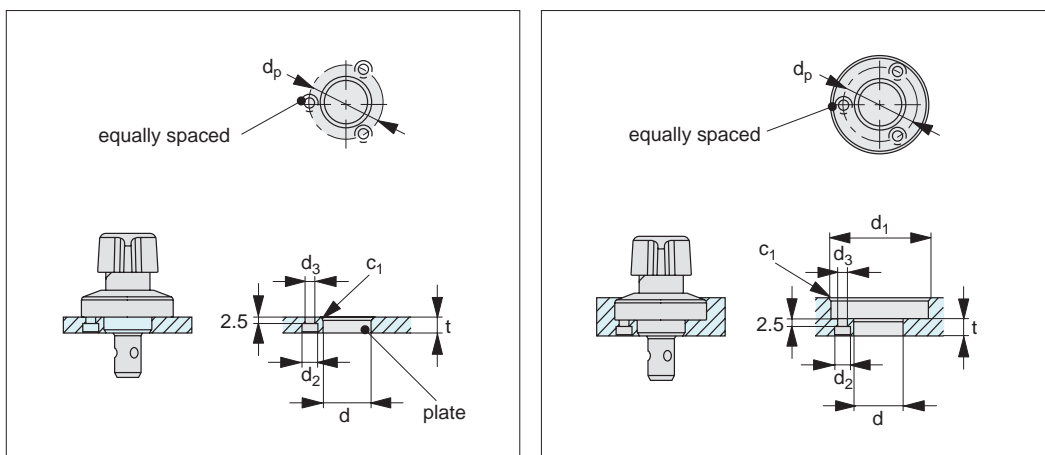

Installation for 6mm panels

Installation for 6mm to 20mm panels

33916/17/18	Single panel thickness $t \pm 0,2$	$d_6 +0,1$ $+0,0$	d_7	d_8	d_9	d_5
.W1006	6	14	-	4,4	2,4	21
.W1006	6 to 10	14	26	4,4	2,4	21
.W1410	6	18	-	6,5	3,4	28
.W1410	6 to 14	18	35	6,5	3,4	28
.W2010	12	18	-	6,5	3,4	28
.W2010	12 to 20	18	35	6,5	3,4	28

Note: if two fasteners used, allow spacing tolerance of $\pm 0,1$ mm



33917

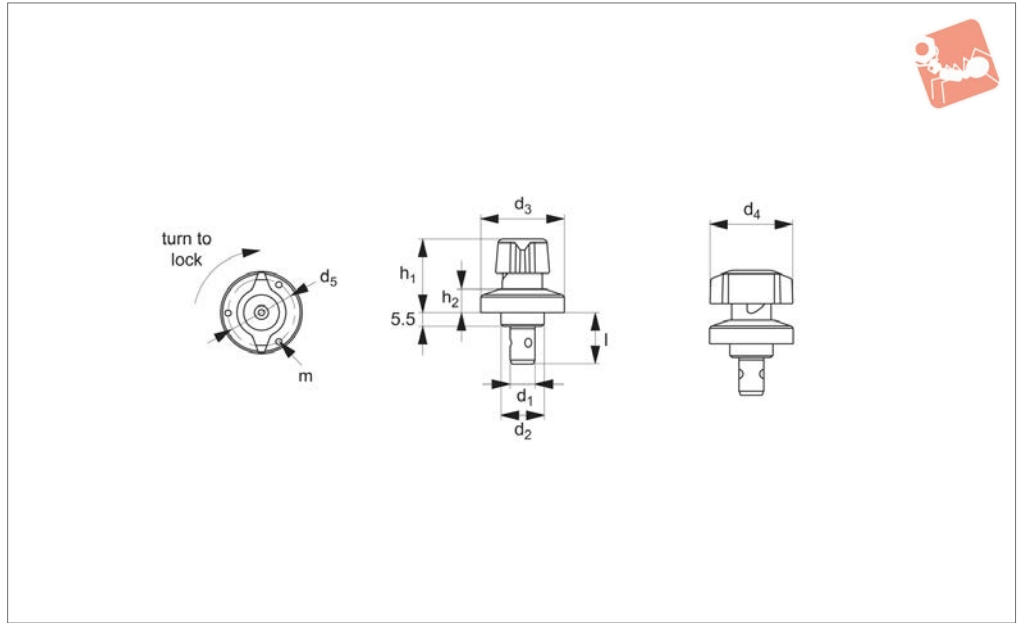

Material

Body: stainless steel
 Shank: steel, nickel plated.
 Knob: stainless steel.
 Ball & spring: stainless steel.

Technical Notes

One-touch fasteners are the ideal solution for applications requiring rapid and recurring change over of tooling or set ups. Use in applications as diverse as bottling processes, machine covers, changing of cogs and drive belts. One-touch fasteners

provide a quick, simple and secure change over solution - no time wasted in unfastening screws or other permanent fixings, and no opportunity for lost fixings in your machinery.

Important Notes

Suitable for panels/enclosures of 6 to 20mm thickness.
 For locating bushes see part no. 33920.
 Quarter turn handle, easy-to-read on/off position of the one-touch fastener for increased security.

Temperature resistant to 180°C.

Actuation:

- Turn handle to off position: locking balls retract and are held in retracted position via notched catch.
- Pass fastener through panel.
- Turn handle 45° to on position: locking balls engage with locating bush, panels are securely fastened.

Order No.	For single panel thickness	d_1 -0.05 -0.10	d_2 tol. h9	d_3	d_4	d_5	h_1	h_2	l	m	Clamping force N	Weight g
33917.W1006	6-10	6	14	25	25	21	24.5	6.5	19.5	M 2x0,4	30	40
33917.W1410	6-14	10	18	34	34	28	31.0	10.0	21.5	M 3x0,5	50	95
33917.W2010	12-20	10	18	34	34	28	31.0	10.0	27.5	M 3x0,5	50	100

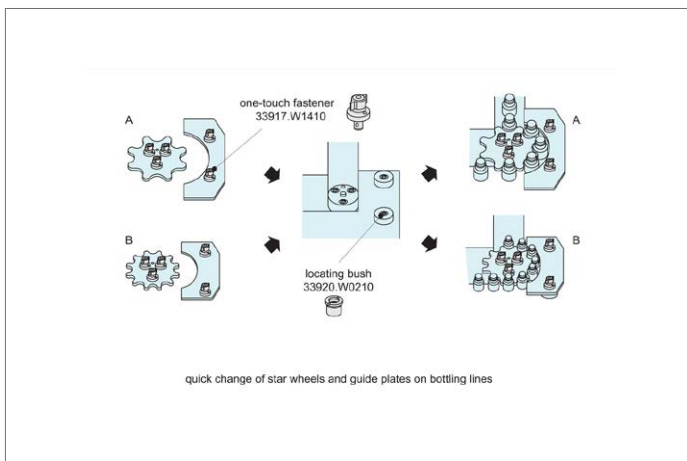



One-Touch Fastener - Ball Locking

quarter turn lock - t-handle grip - stainless steel



One Touch Fasteners

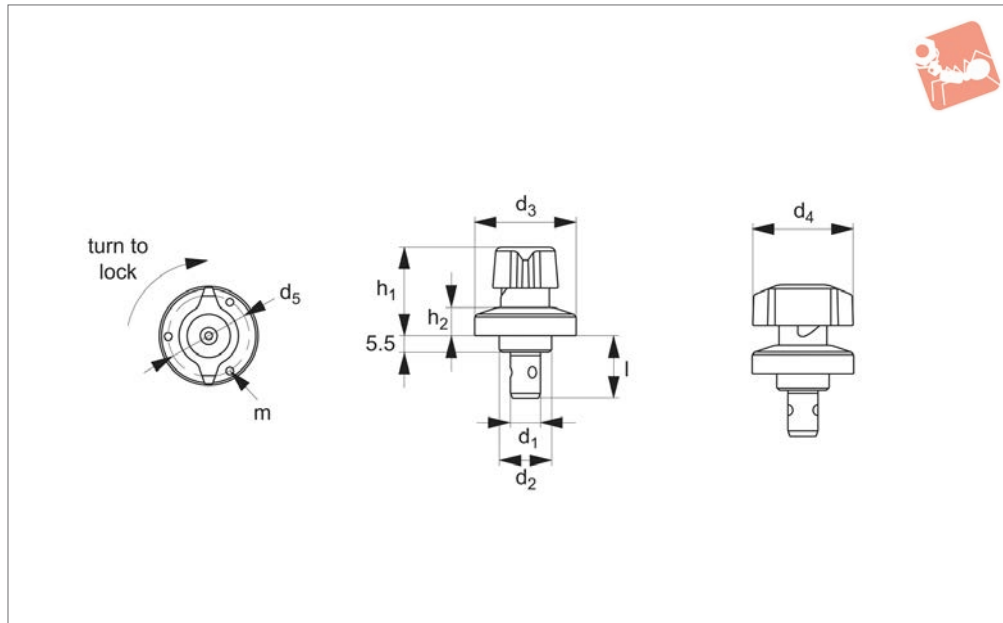

33918

ONE TOUCH FASTENERS

Material

Body & shank: stainless steel.
Knob: stainless steel.
Ball & spring: stainless steel.

Technical Notes

One-touch fasteners are the ideal solution for applications requiring rapid and recurring change over of tooling or set ups. Use in applications as diverse as bottling processes, machine covers, changing of cogs and drive belts. One-touch fasteners

provide a quick, simple and secure change over solution - no time wasted in unfastening screws or other permanent fixings, and no opportunity for lost fixings in your machinery.

Important Notes

Suitable for panels/enclosures of 6 to 20mm thickness.
For locating bushes see part no. 33920.
Quarter turn handle, easy-to-read on/off position of the one-touch fastener for

increased security.
Temperature resistant to 180°C.

Actuation:

- Turn handle to off position: locking balls retract and are held in retracted position via notched catch.
- Pass fastener through panel.
- Turn handle 45° to on position: locking balls engage with locating bush, panels are securely fastened.

Order No.	For single panel thickness	d_1 -0.05 -0.10	d_2 tol. h9	d_3	d_4	d_5	h_1	h_2	l_1	m	Clamping force N	Weight g
33918.W1006	3-10	6	14	25	25	21	24.5	6.5	19.5	M 2x0,4	30	40
33918.W1410	3-14	10	18	34	34	28	31.0	10.0	21.5	M 3x0,5	50	120
33918.W2010	12-20	10	18	34	34	28	31.0	10.0	27.5	M 3x0,5	50	100

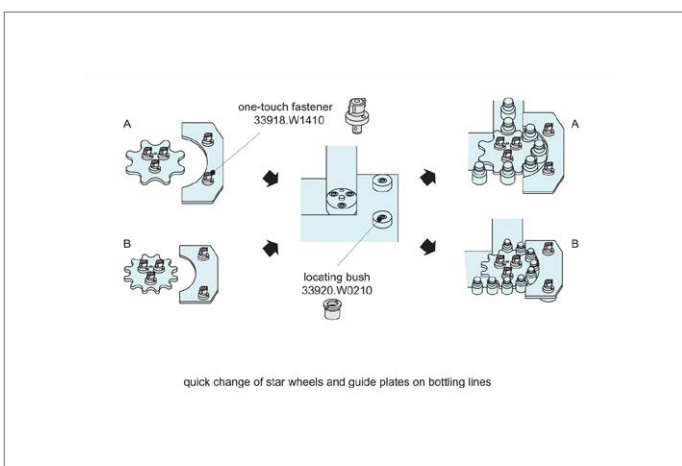



33920

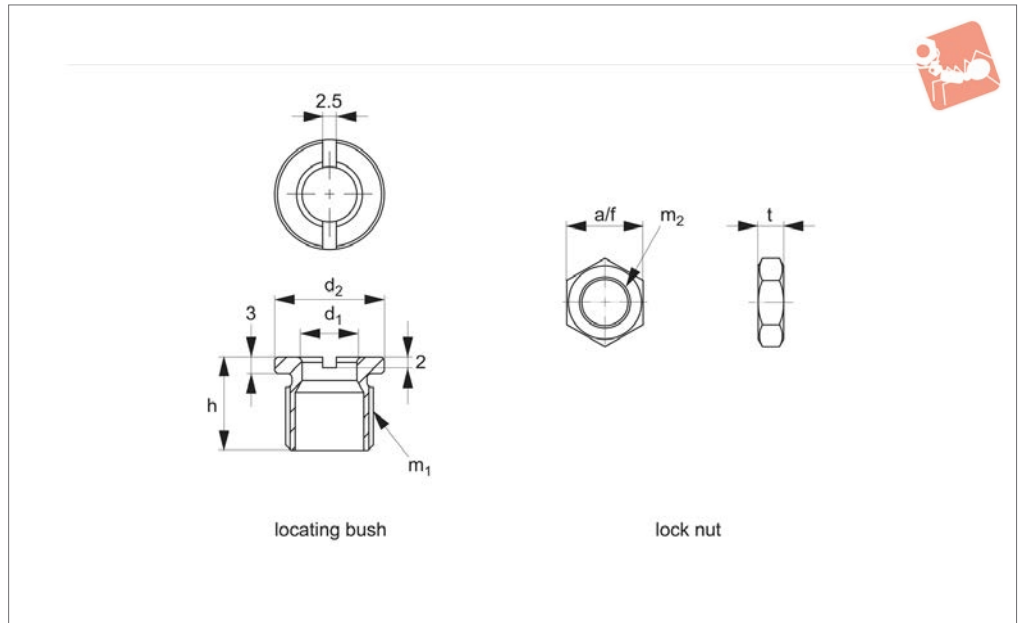

Material

Body: steel or stainless steel SUS303.
Nut: stainless steel SUS303.

Technical Notes

Used in conjunction with one-touch fasteners 33910 to 33918, locating bushes 33920 provide secure fastening of panels and covers. Locating bushes are of particular use in soft metals, such as aluminium where receiving surfaces may wear. One-

touch fasteners are the ideal solution for applications requiring rapid and recurring change over tooling or set ups. Use in applications as diverse as bottling processes, machine covers, changing of cogs and drive belts.

Tips

While we recommend the use of locating bushes as receivers for our one-touch fasteners, it is also possible to mount one-

touch fasteners without them, see specifications opposite.

Important Notes

Suitable for panels/enclosures of 6 to 20mm thickness. For one-touch fasteners see part no. 33910 to 33918. For installation instructions see technical page. Temperature resistant to 180°C.

Order No.	Type	Material	d_1 +0.4 +0.2	d_2 tol. h9	h	m_1	For panel thickness	Weight g
33920.W0006	Bush	Steel	6	16	15	M12x1,5	>6	9
33920.W0010	Bush	Steel	10	20	17	M16x1,5	>6	13
33920.W0206	Bush	S/S	6	16	15	M12x1,5	>6	9
33920.W0210	Bush	S/S	10	20	17	M16x1,5	>6	13

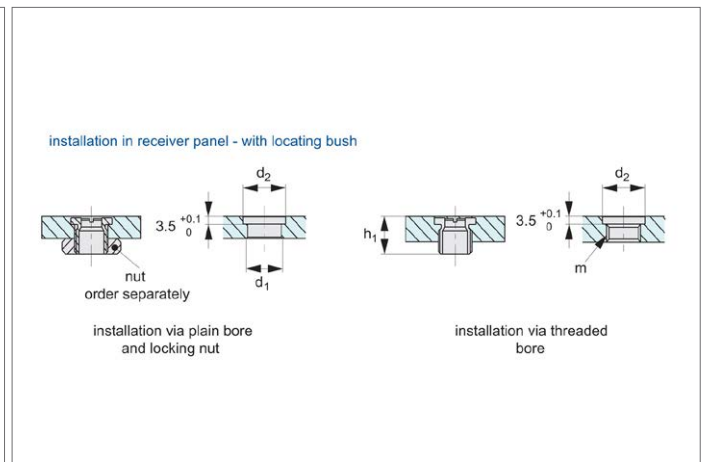
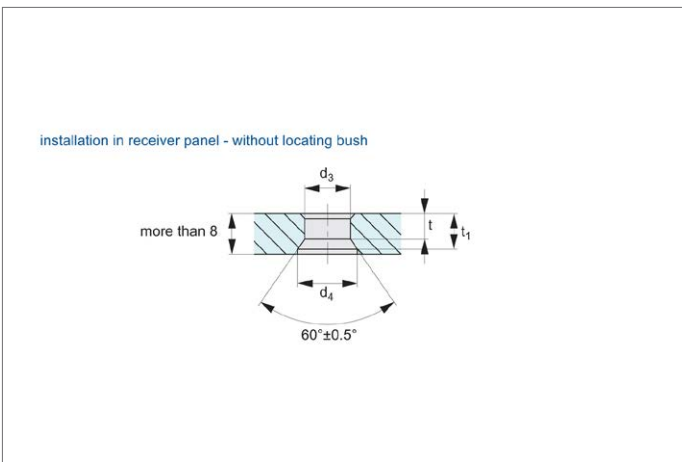



One-Touch Fasteners - Alternatives to Screws

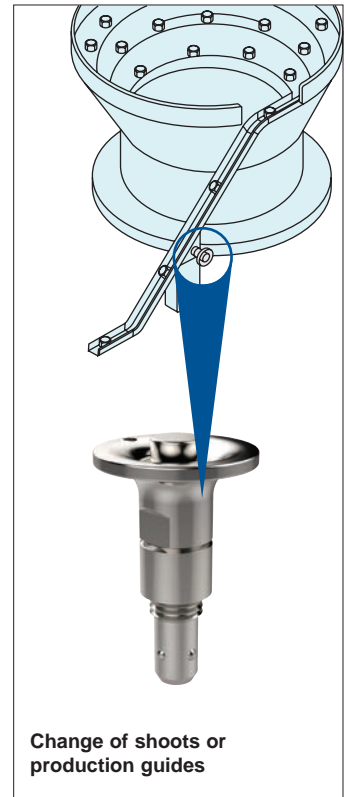
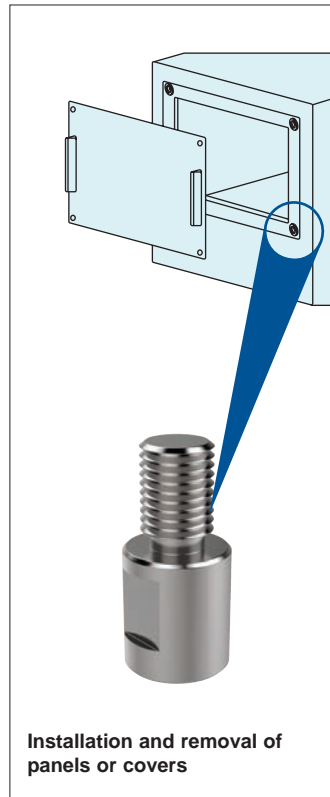
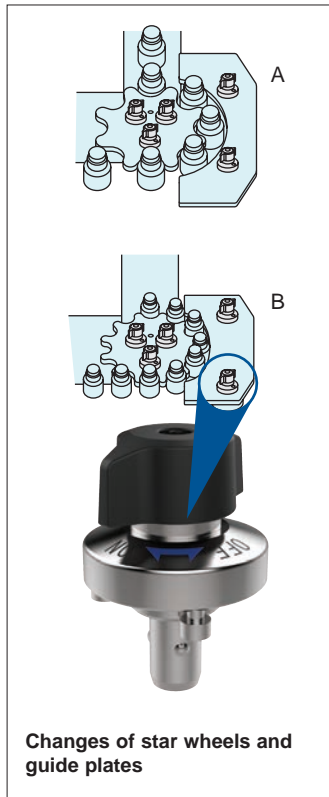
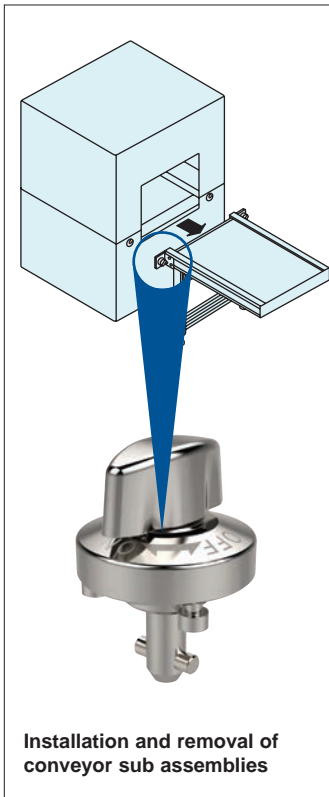

ONE TOUCH FASTENERS

Easy & Secure! For Quick Changeover with No Tools!





One-Touch Change Over

Installation and Removal of Rotary Blades and Changes of Shooters

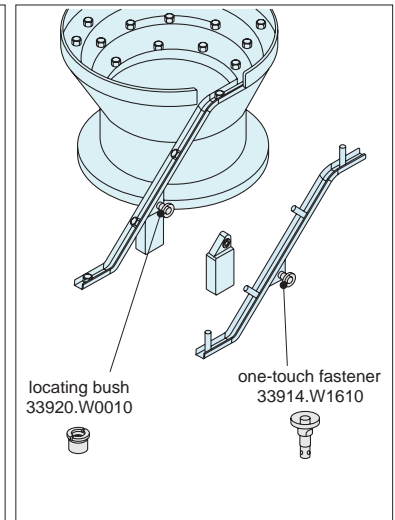
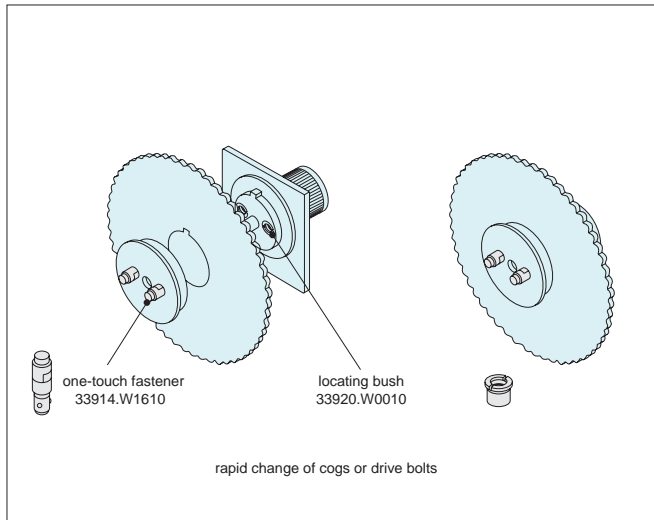

Changes of Star Wheels and Guide Plates

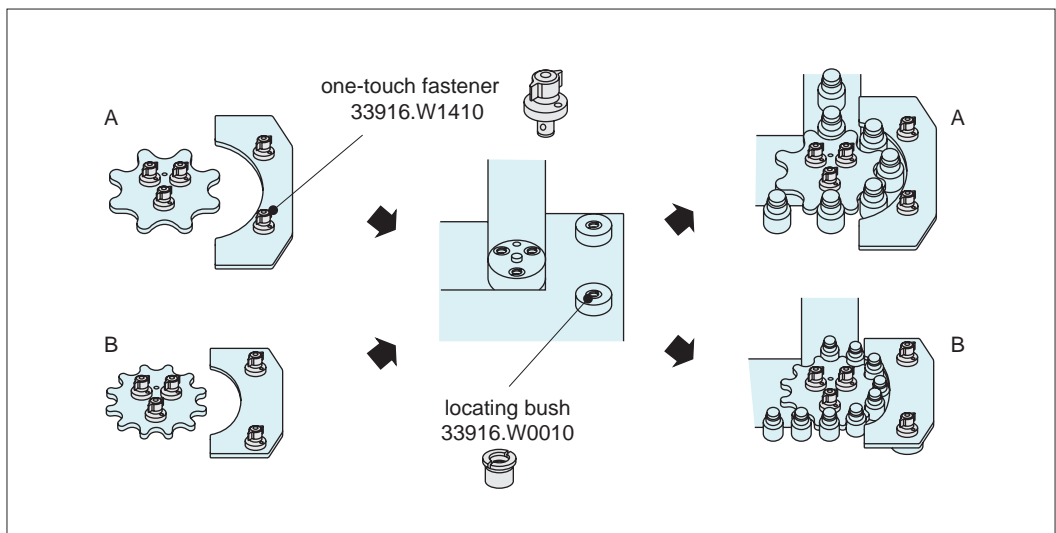

Changes of Pusher and Changes of Chuck Handling Machines

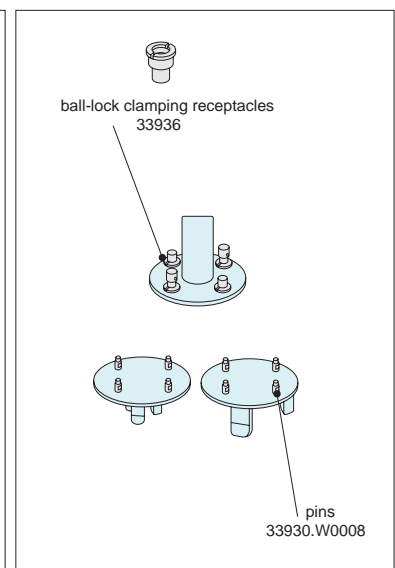
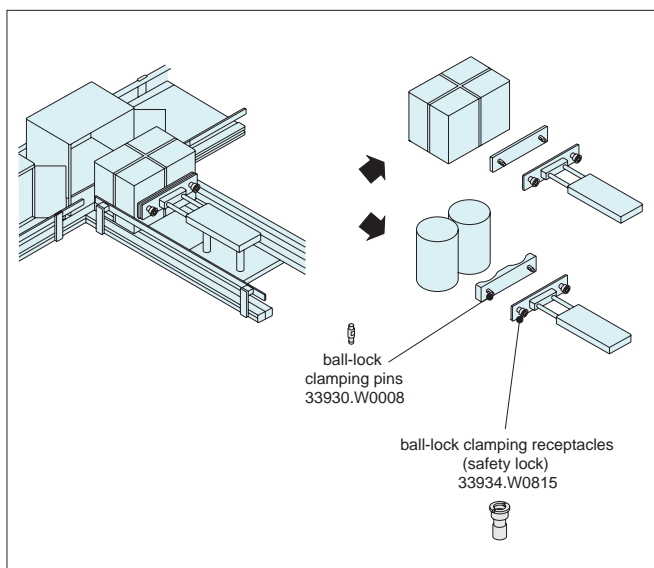



One-Touch Fastener - Ball Locking

technical information

33910 - 33920

Positioning Elements

Operating Instructions

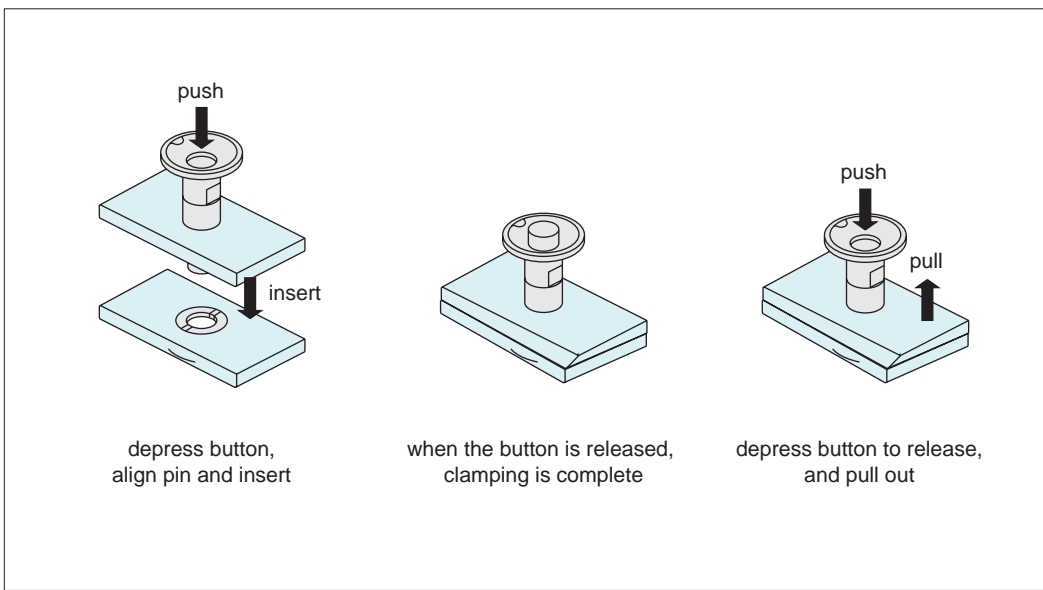

Operating Principle

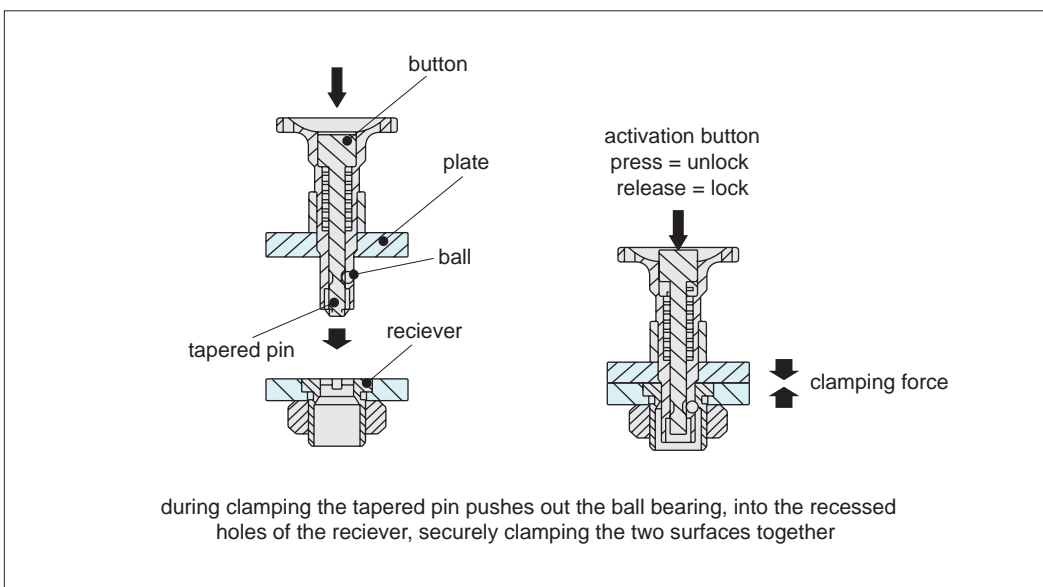

ONE TOUCH FASTENERS

ov-W33910-A-T-W33920-A-T-ball-locking-one-touch-fasteners-a-rmh - Updated - 27-10-2022



33923

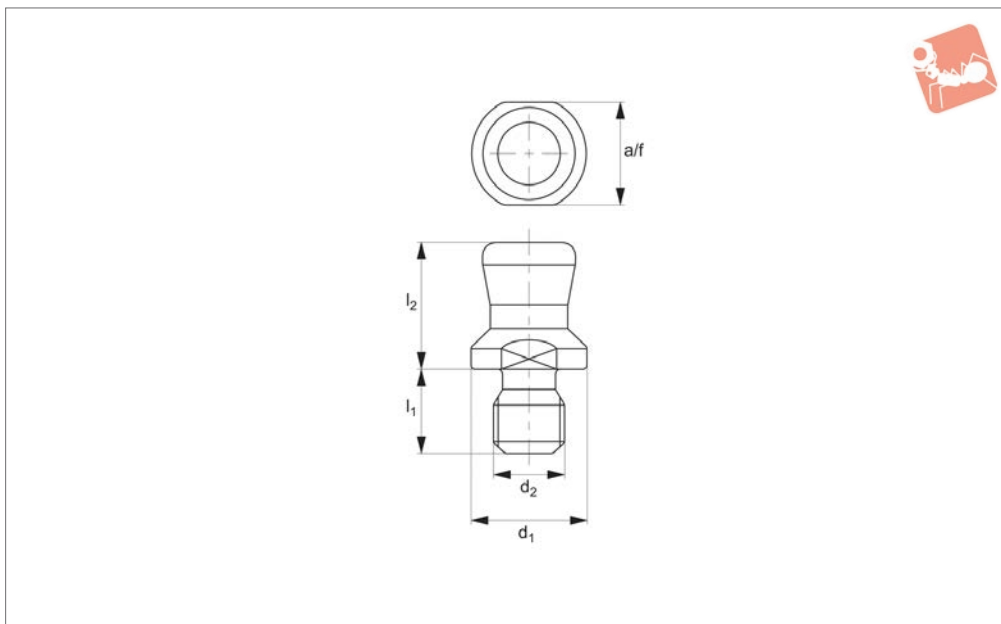

Material

Body: stainless steel, SUS630

Technical Notes

One-touch fasteners are the ideal solution for applications requiring rapid and recurring change over of tooling or set ups. Use in applications as diverse as bottling processes, machine covers, changing of

cogs and drive belts. One-touch fasteners provide a quick, simple and secure change over solution - no time wasted in unfastening screws or other permanent fixings, and no opportunity for lost fixings in your machinery.

Important Notes

Pin 33923 for use in conjunction with one-

touch fasteners, ball clamping; 33924 through 33929. Pins for installation in material to minimum depth 6,0mm or greater. Recess of 0,5mm +0,1 is recommended to ensure full surface contact and achieve maximum strength of pin.

Order No.	d_1 -0.05 -0.10	d_2	l_1	l_2	A/F	Weight g
33923.W0006	6	M 4x0,7	5.8	7.6	5	2
33923.W0008	8	M 5x0,8	5.8	8.7	7	3

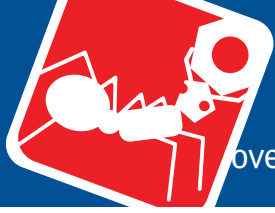

Installation Dimensions

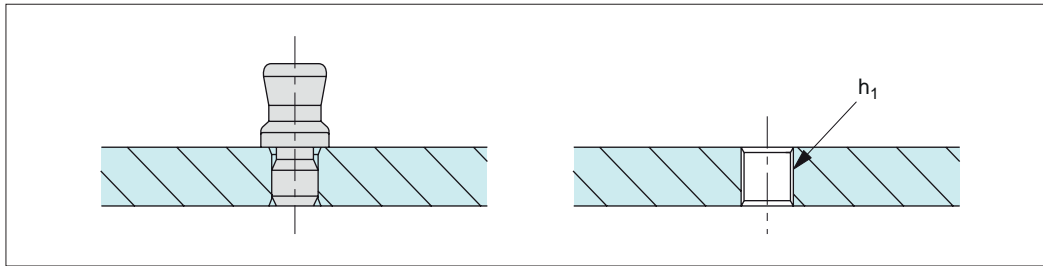

Standard Mount

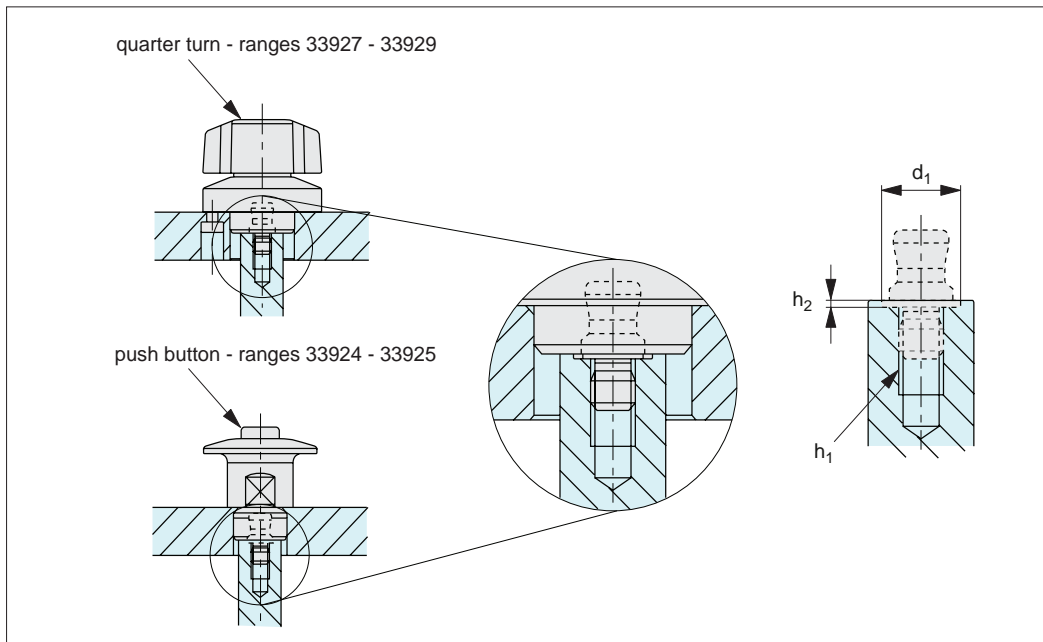

Recessed Mount

Prepare a tapped hole according to the thread of the pin. Ensure a counter bore is machined to depth h_2 to complete pin installation.

	Mounting type	h_1	h_2 +0,1	d_3
33923.W0006	Standard	M4x0,7	-	-
33923.W0006	Recessed	M4x0,7	0,5	7
33923.W0008	Standard	M5x0,8	-	-
33923.W0008	Recessed	M5x0,8	0,5	9



33926

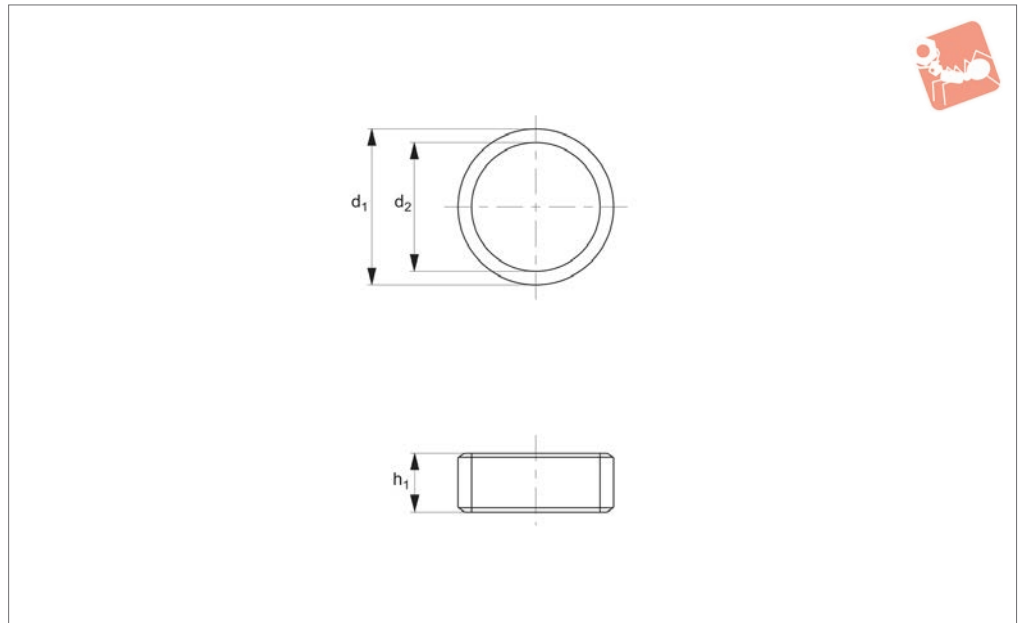

Material

Stainless steel SUS303

Technical Notes

For use with one-touch fasteners 33924

and 33925. Spacer adapts thread length of one-touch fastener to different thread reaches on mounting panels of different thickness.

Order No.	For panel thickness	d_1	d_2 +0.2 +0.01	h_1 +0.05	Weight g
33926.W1604	6	19	16	4	2.5
33926.W1605	5	19	16	5	3.0
33926.W1606	4	19	16	6	3.5
33926.W1607	3	19	16	7	4.0

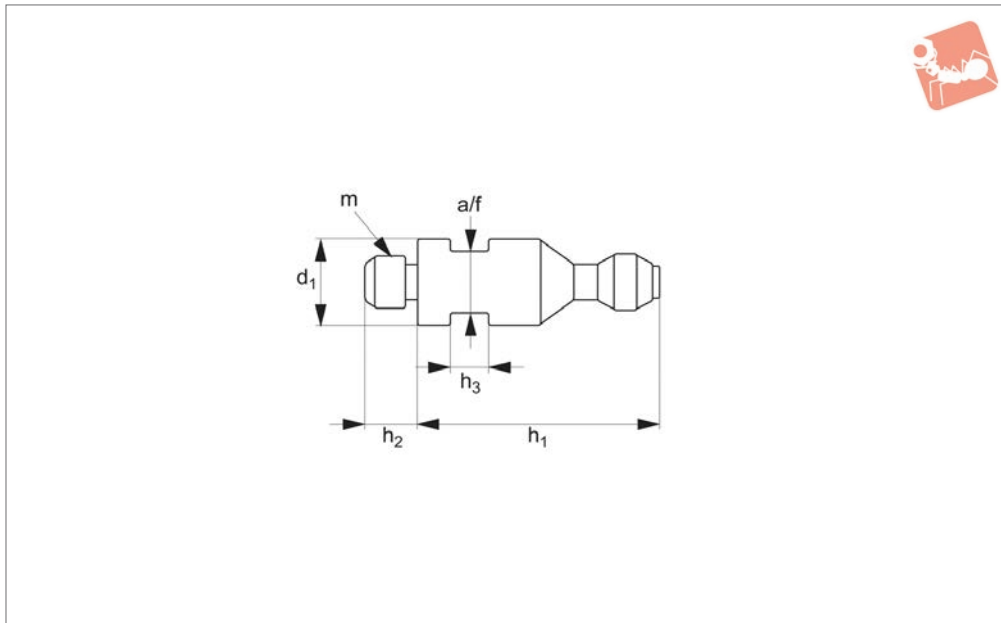

33930

ONE TOUCH FASTENERS

Material

Body: steel, nickel plated.

Technical Notes

One-touch fasteners are the ideal solution for applications requiring rapid and recurring change over of tooling or set ups. Use in applications as diverse as bottling processes, machine covers, changing of

cogs and drive belts. One-touch fasteners provide a quick, simple and secure change over solution - no time waste in unfastening screws or other permanent fixings, and no opportunity for lost fixings in your machinery.

Important Notes

Pin 33930 is for use inconjunction with

one-touch fasteners, ball clamping; 33934 and 33936. Suitable for panels/enclosures of 6 to 20 mm thickness. Requires an M 6 thread, 6mm deep for installation into blind hole. See technical pages for further information.

Order No.	d_1 -0.2 -0.4	h_1	h_2	h_3	m	A/F	Weight g
33930.W0008	Ø8	23	5	4	M 5x0,8	6	7

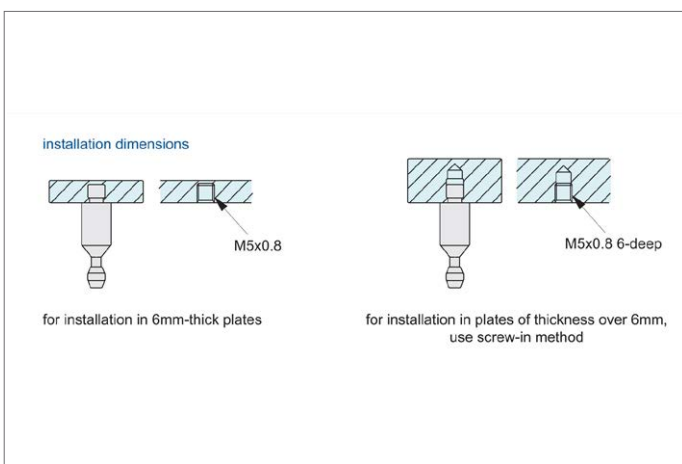



33934

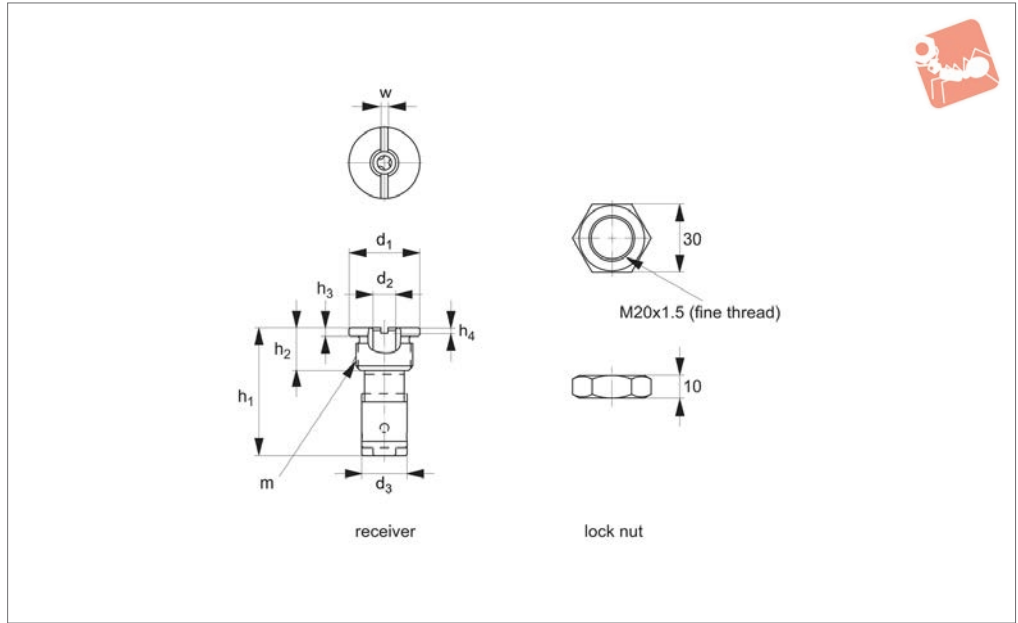

Material

Body: steel, nickel plated.
Balls: stainless steel.

Technical Notes

One-touch fasteners are the ideal solution for applications requiring rapid and recurring change over of tooling or set ups. Used in applications as diverse as bottling processes, machine covers, changing of cogs and drive belts. One-touch fasteners provide a quick, simple and secure change

over solution - no time waste in unfastening screws or other permanent fixings, and no opportunity for lost fixings in your machinery.

Temperature resistant to 180°C.

Important Notes

Suitable for panels/enclosures of 6 to 32 mm thickness. Used in conjunction with pin 33930. Offers a safety release feature to prevent accidental release in of pin/assembly.

* Tensile strength stated is for locked position/state of the fastener.

Actuation:

Engage pin into receiver, a positive „click“ is heard, securing balls are engaged. Panels are securely fastened. To release, pull safety release housing on under side of receiver, balls are retracted and panel is released.

Order No.	Type	d ₁ tol. h9	d ₂ +0.10 +0.50	d ₃	h ₁	h ₂	h ₃	h ₄	m	w	Clamping force N	Shear strength N	Tensile strength N	Weight g
33934.W0807	Receiver	Ø26	Ø8	Ø16	45	15	3	2	M20x1,5	2,5	7	1800	1800	65
33934.W0815	Receiver	Ø26	Ø8	Ø16	45	15	3	2	M20x1,5	2,5	17	1800	1800	65

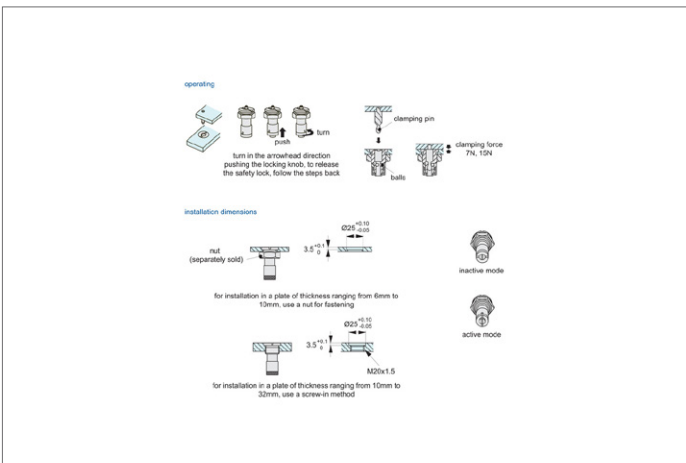



One-Touch Fastener - Ball Clamping

locating bush and receiver - mechanical release



One Touch Fasteners

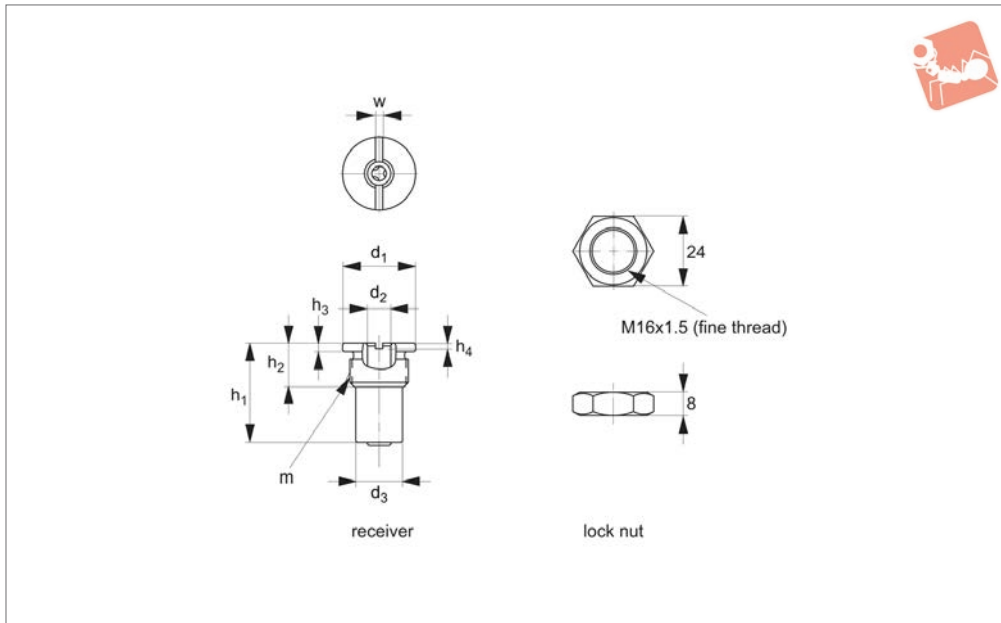

33936

ONE TOUCH FASTENERS

Material

Body: steel, nickel plated.
Balls & spring: stainless steel.

Technical Notes

One-touch fasteners are the ideal solution for applications requiring rapid and recurring change over of tooling or set ups. Use in applications as diverse as bottling processes, machine covers, changing of cogs and drive belts. One-touch fasteners provide a quick, simple and secure change

over solution - no time waste in unfastening screws or other permanent fixings, and no opportunity for lost fixings in your machinery. Temperature resistant to 180°C.

Important Notes

Suitable for panels/enclosures of 6 to 32 mm thickness. Used inconjunction with pin 33930. Mechanical release only (no safety release).

* Tensile strength stated is for locked posi-

tion/state of the fastener.

Actuation:

Engage pin into receiver, a positive „click“ is heard, securing balls are engaged. Panels are securely fastened. To release, simply pull panels apart with sufficient force to overcome securing balls, panel is released.

Order No.	Type	d ₁ tol. h9	d ₂ +0.10 +0.05	d ₃	h ₁	h ₂	h ₃	m	w	Clamping force N	Shear strength N	Tensile strength N	Weight g
33936.W0807	Receiver	Ø20	Ø8	Ø14	29	15	3	M16x1,5	2,5	7	1800	1800	30
33936.W0815	Receiver	Ø20	Ø8	Ø14	29	15	3	M16x1,5	2,5	15	1800	1800	30

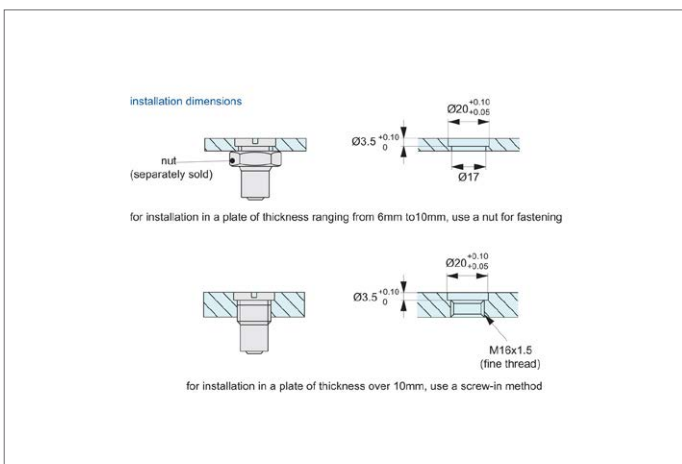



33924

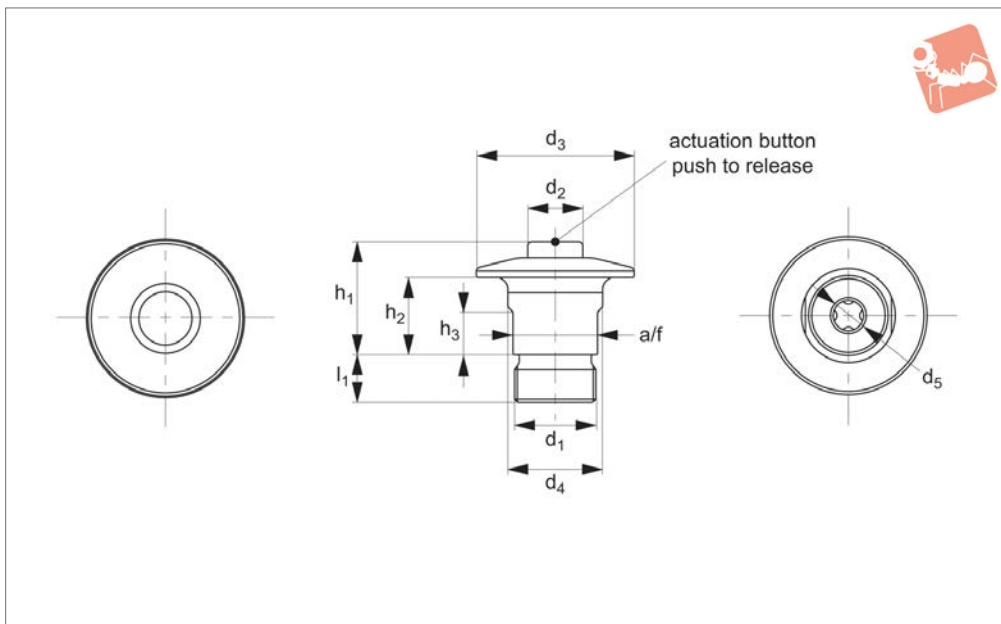

Material

Body: stainless steel SUS303
 Ball: stainless steel SUS440
 Spring: stainless steel SUS304
 O-Ring: fluororubber

Technical Notes

One-touch fasteners are the ideal solution for applications requiring rapid and recurring change over of tooling or set ups. Use in applications as diverse as bottling processes, machine covers, changing of cogs and drive belts. One-touch fasteners provide a quick, simple and secure change

over solution - no time wasted in unfastening screws or other permanent fixings, and no opportunity for lost fixings in your machinery. Temperature resistant to 180°C.

Tips

Used in conjunction with pin 33923. For highly accurate locating, use locating pins 36340 & 36341

Important Notes

Suitable for panel/enclosures of 3 to 10mm thickness.

Used in conjunction with pin 33923. Tensile strength stated is for locked position/state of fastener.

Actuation:

- Engage clamp over pin, no need to push button, a positive „click“ is heard.
- Securing balls are locked and panel fastened.
- To release; while pushing down on release button, lift panel from pin- panel is released.

Order No.	For single panel thickness	For pin dia.	d ₁	d ₂	d ₃	d ₄	d ₅ +0.4 +0.2	h ₁	h ₂	h ₃	l ₁	A/F	Clamping force N	Shear strength N	Tensile strength N	Weight g
33924.W1006	3-10	6	M16x1,0	11	32	19	6	23	15,5	8,5	9,5	17	6	1100	250	65



One-Touch Fastener - Ball Clamping

push button lock - straight body - stainless



One Touch Fasteners

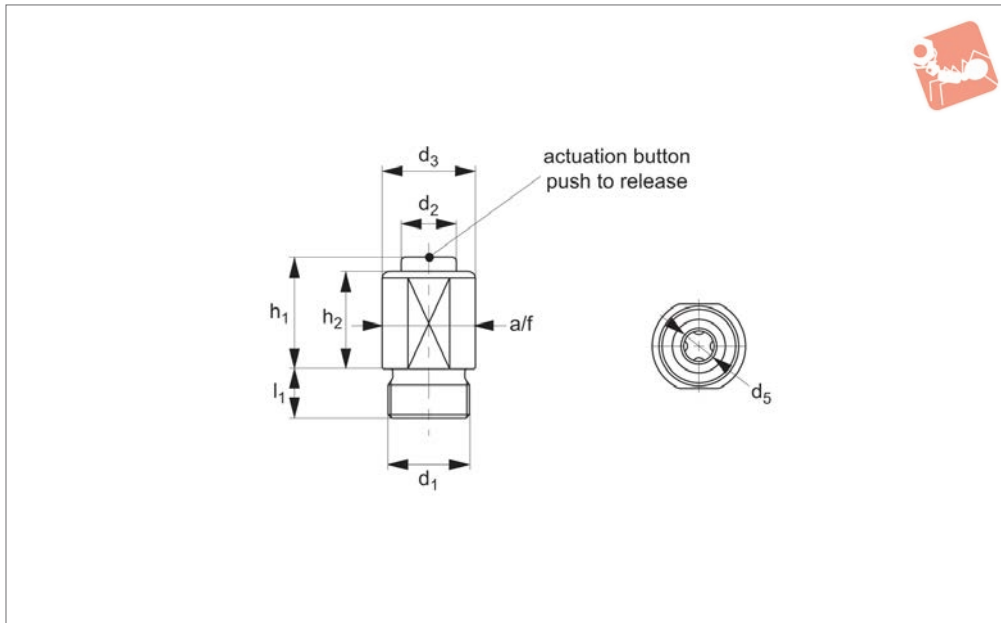

33925

ONE TOUCH FASTENERS

Material

Body: stainless steel SUS303
 Ball: stainless steel SUS440
 Spring: stainless steel SUS304
 O-Ring: fluororubber

Technical Notes

One-touch fasteners are the ideal solution for applications requiring rapid and recurring change over of tooling or set ups. Use in applications as diverse as bottling processes, machine covers, changing of cogs and drive belts. One-touch fasteners

provide a quick, simple and secure change over solution - no time wasted in unfastening screws or other permanent fixings, and no opportunity for lost fixings in your machinery. Temperature resistant to 180°C.

Tips

Used in conjunction with pin 33923.

Important Notes

Suitable for pannel/enclosures of 3 to 27mm thickness. Used in conjunction

with pin 33923. Tensile strength stated is for locked position/state of fastener.

Actuation:

- To lock; engage clamp over pin, no need to push button, a positive „click“ is heard.
- Securing balls are locked and panel fastened.
- To release; while pushing down on release button, lift panel from pin- panel is released.

Order No.	For single panel thickness	For pin dia.	d ₁	d ₂	d ₃	d ₅ +0.4 +0.2	h ₁	h ₂	l ₁	A/F	Clamping force N	Shear strength N	Tensile strength N	Weight g
33925.W2706	3-27	6	M16x1,0	11	19	6	23	19.5	9.5	17	6	1100	250	50



Operating Principle

Four ball bearings clamp onto the clamping pin (33923), the wedge shape of the pin draws the panels together during clamping.

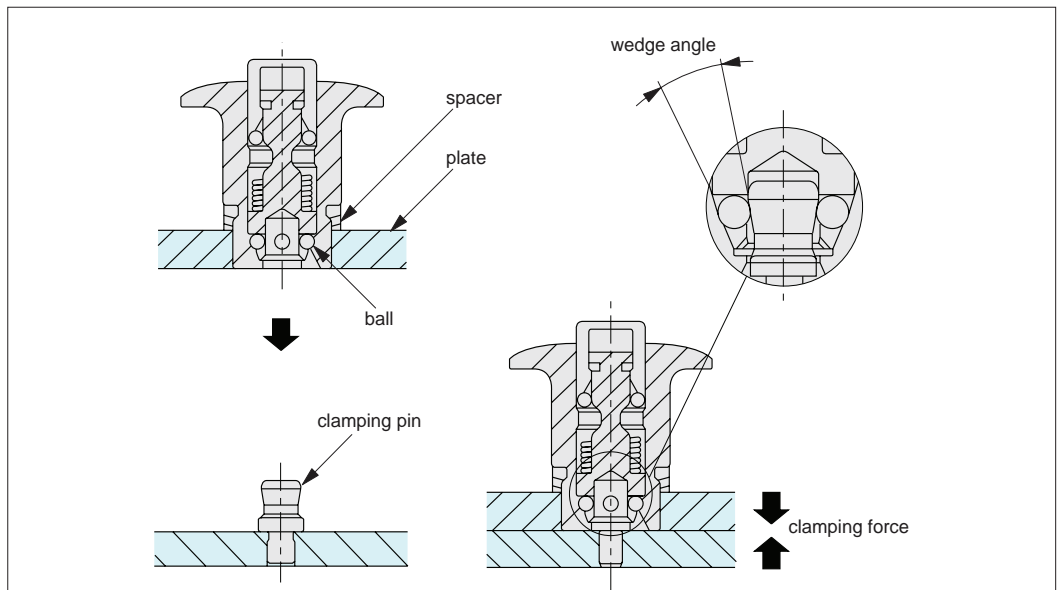

Operating Instructions

- 1 Engage clamp over pin, no need to push button, a positive "click" is heard.
- 2 Securing balls are locked and panel fastened.
- 3 To release; while pushing down on release button, lift panel from pin - panel is released.

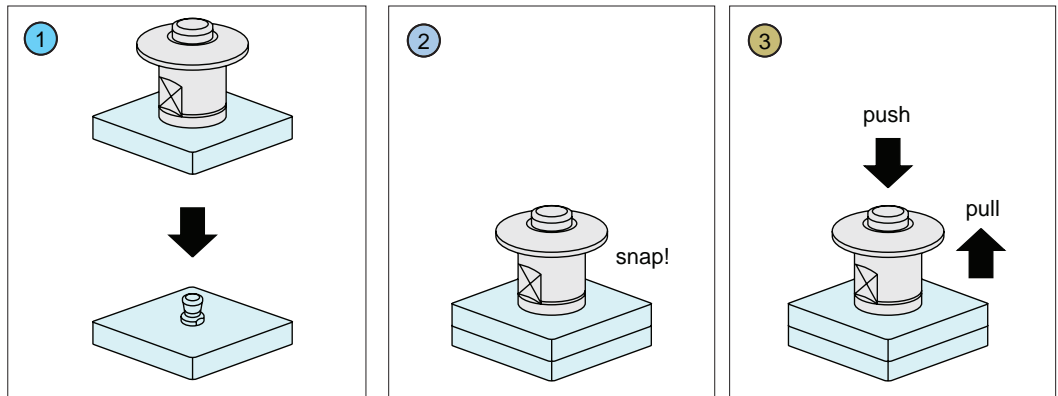



One Touch Fastener Applications

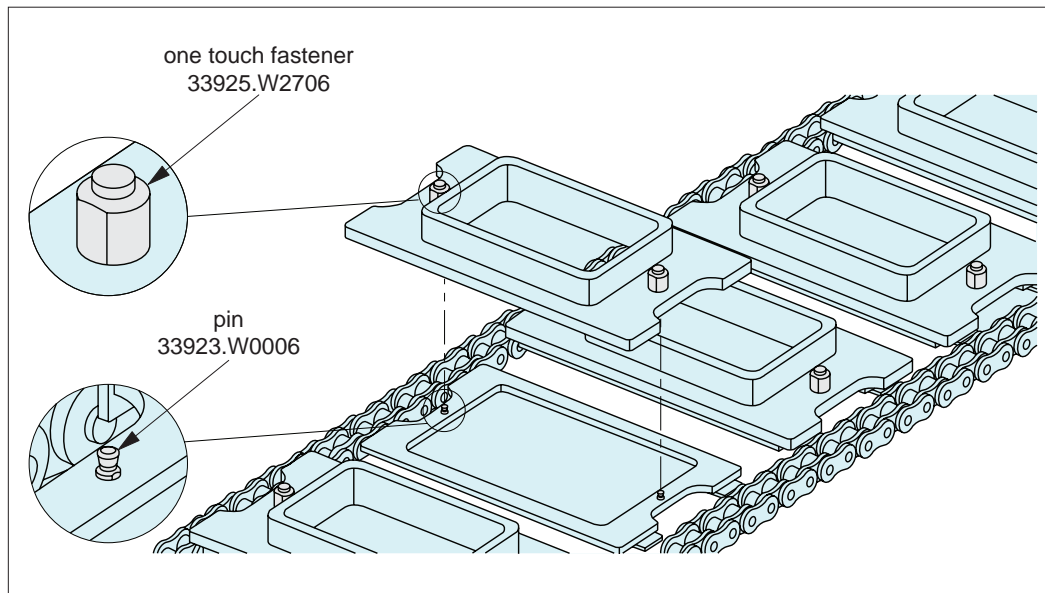

Changes of Trays and Containers on Conveyers

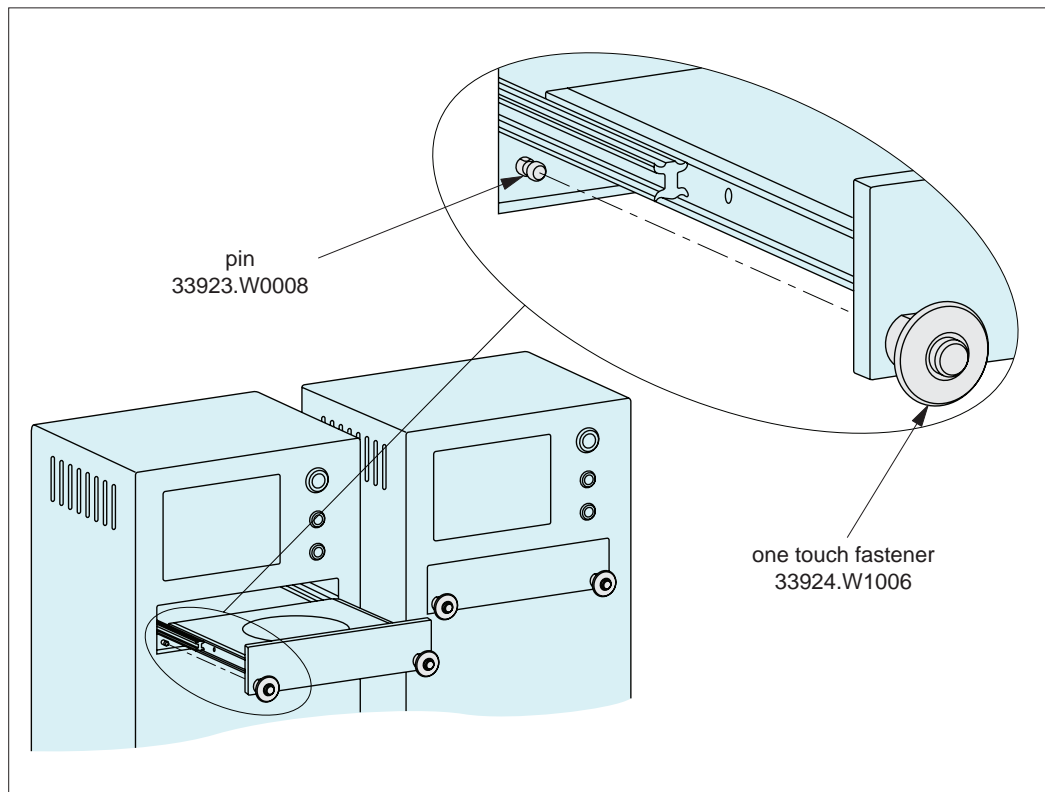

Securing Sliding Elements Such as Drawers

ONE TOUCH FASTENERS

ov-W33925-A-T-ball-clamping-one-touch-fasteners-installation-b-rmh - Updated - 27-10-2022



Installation Dimensions

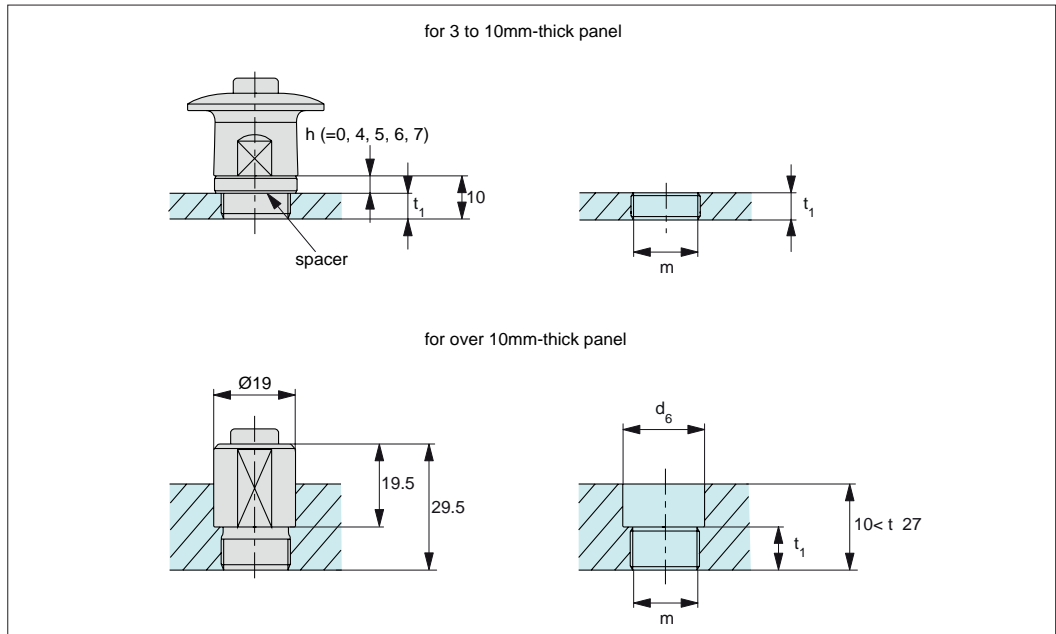

Installation Best Practice

Panel Tolerances

Spacing tolerance on both the sub panel and the base panel should be ± 0.1 .

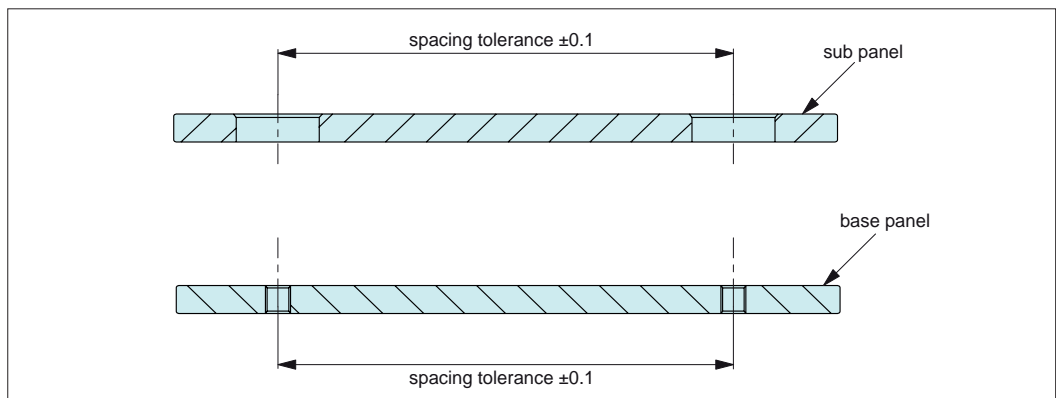

Repeatability

For highly accurate locating, use locating pins 36340 or 36341. Repeatability of ± 0.25 is achievable.

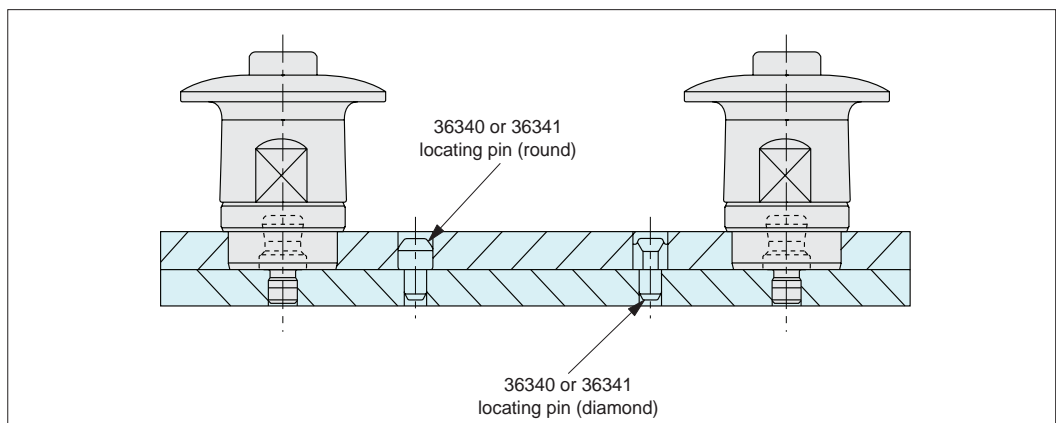



One-Touch Fastener - Ball Clamping

quarter turn lock - t-handle grip - steel



One Touch Fasteners

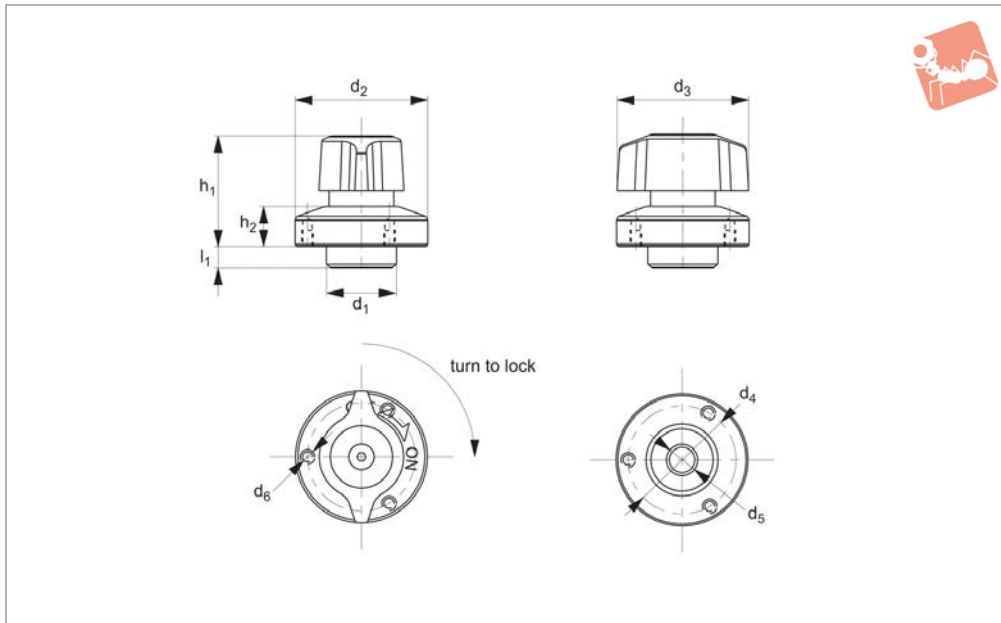

33927

ONE TOUCH FASTENERS

Material

Body & Shank: steel, nickel plated.
Knob: polyamide, black.
Ball & Spring: Stainless steel.

Technical Notes

One-touch fasteners are the ideal solution for applications requiring rapid and recurring change over of tooling or set ups. Use in applications as diverse as bottling

processes, machine covers, changing of cogs and drive belts. One-touch fasteners provide a quick, simple and secure change over solution - no time wasted in unfastening screws or other permanent fixings, and no opportunity for lost fixings in your machinery.

Tips

Used in conjunction with pin 33923.

For highly accurate locating, use locating pins 36340 & 36341.

Actuation

- Turn handle to off position, clamping balls are retracted. Engage panel and clamp over clamping pin. Turn handle on to position to clamp.
- To unclamp, reverse steps above.

Order No.	For single panel thickness	For pin dia.	d ₁ tol. h9	d ₂	d ₃	d ₄	d ₅ +0.4 +0.2	d ₆	h ₁	h ₂	l ₁	Clamping force N	Shear strength N	Tensile strength N	Weight g
33927.W1006	6-10	6	14	25	25	21	6	M2x0,4	23	6,5	5,5	7	1100	250	35
33927.W1408	6-14	8	18	34	34	28	8	M3x0,5	28	10,0	5,5	9	1800	400	85

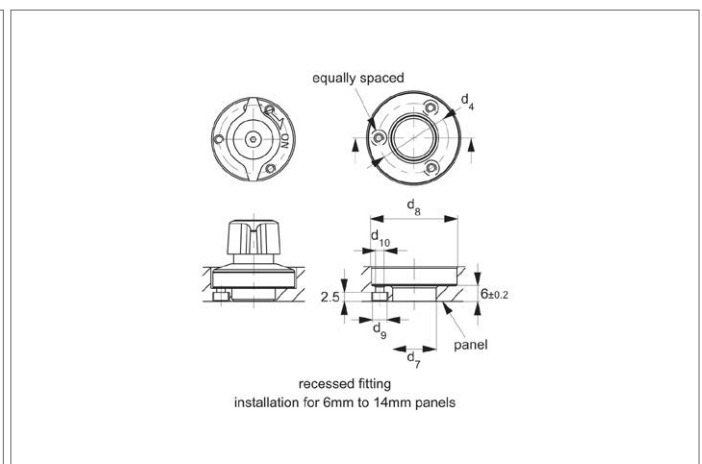
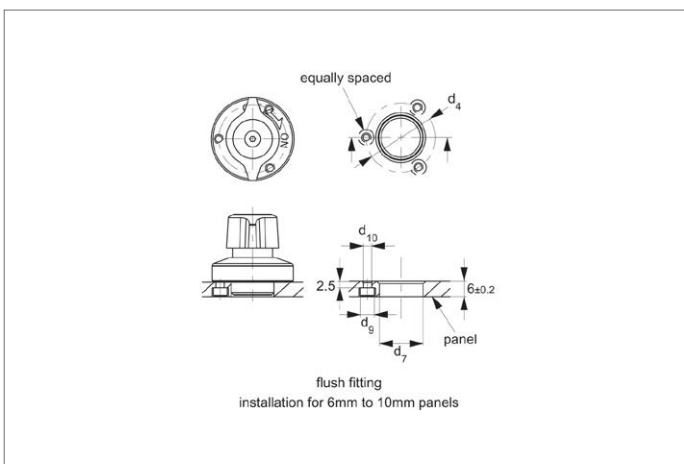



33928

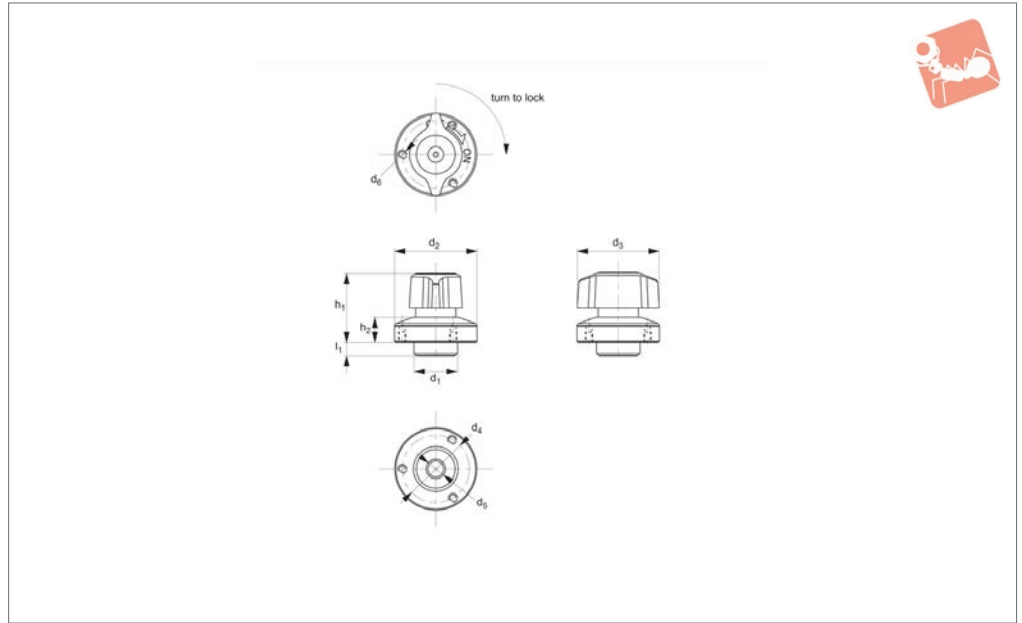

Material

Body & shank: steel, nickel plated.
 Knob: tainless steel.
 Ball & spring: stainless steel.

Technical Notes

One-touch fasteners are the ideal solution for applications requiring rapid and recurring change over of tooling or set ups. Use in applications as diverse as bottling

processes, machine covers, changing of cogs and drive belts. One-touch fasteners provide a quick, simple and secure change over solution - no time wasted in unfastening screws or other permanent fixings, and no opportunity for lost fixings in your machinery.

Tips

Used in conjunction with pin 33923.

For highly accurate locating, use locating pins 36340 & 36341.

Actuation

-Turn handle to off position, clamping balls are retracted. Engage panel and clamp over clamping pin. Turn handle on to position to clamp.

-To unclamp, reverse steps above.

Order No.	For single panel thickness	For pin dia.	d ₁ tol. h9	d ₂	d ₃	d ₄	d ₅ +0.4 +0.2	d ₆	h ₁	h ₂	l ₁	Clamping force N	Shear strength N	Tensile strength N	Weight g
33928.W1006	6-10	6	14	25	25	21	6	M2x0,4	23	6,5	5,5	7	1100	250	35
33928.W1408	6-14	8	18	34	34	28	8	M3x0,5	28	10,0	5,5	9	1800	400	85

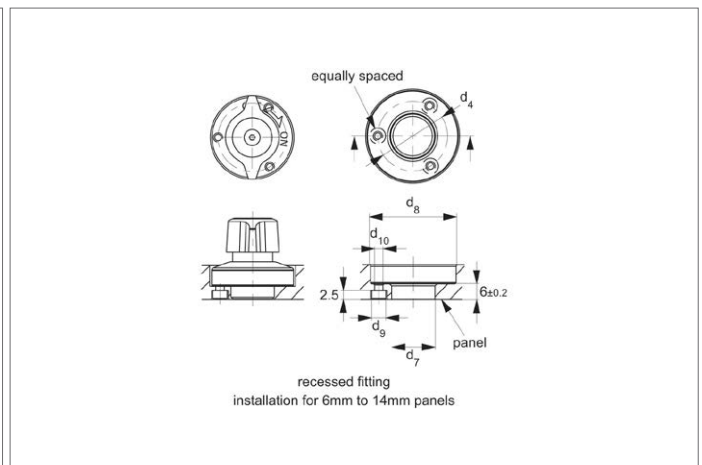
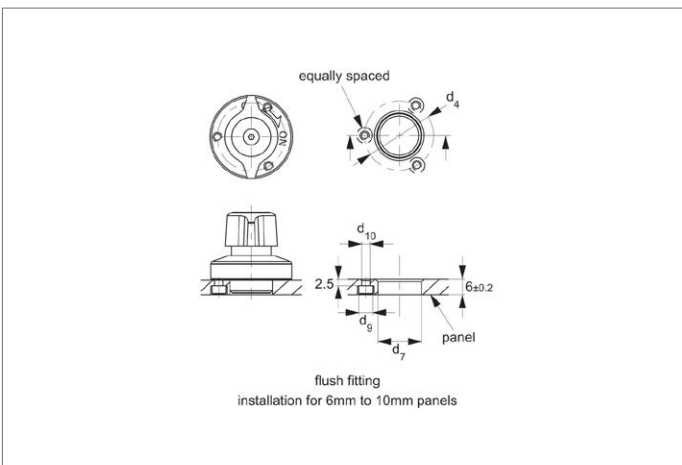



One-Touch Fastener - Ball Clamping

quarter turn lock - t-handle - stainless steel



One Touch Fasteners

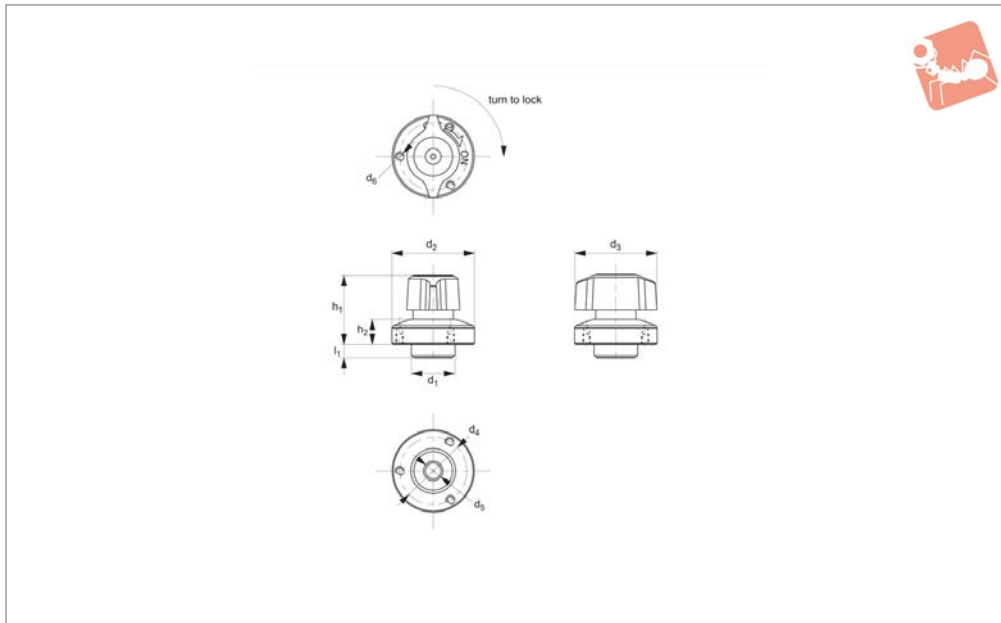

33929

ONE TOUCH FASTENERS

Material

Body & shank: stainless steel.
Knob: stainless steel.
Ball & spring: stainless steel.

Technical Notes

One-touch fasteners are the ideal solution for applications requiring rapid and recurring change over of tooling or set ups. Use in applications as diverse as bottling

processes, machine covers, changing of cogs and drive belts. One-touch fasteners provide a quick, simple and secure change over solution - no time wasted in unfastening screws or other permanent fixings, and no opportunity for lost fixings in your machinery.

Tips

Used in conjunction with pin 33923.

For highly accurate locating, use locating pins 36340 & 36341.

Actuation

- Turn handle to off position, clamping balls are retracted. Engage panel and clamp over clamping pin. Turn handle on to position to clamp.
- To unclamp, reverse steps above.

Order No.	For single panel thickness	For pin dia.	d ₁ tol. h9	d ₂	d ₃	d ₄	d ₅ +0.4 +0.2	d ₆	h ₁	h ₂	l ₁	Clamping force N	Shear strength N	Tensile strength N	Weight g
33929.W1006	6-10	6	14	25	25	21	6	M2x0,4	23	6,5	5,5	7	1100	250	35
33929.W1408	6-14	8	18	34	34	28	8	M3x0,5	28	10,0	5,5	9	1800	400	85

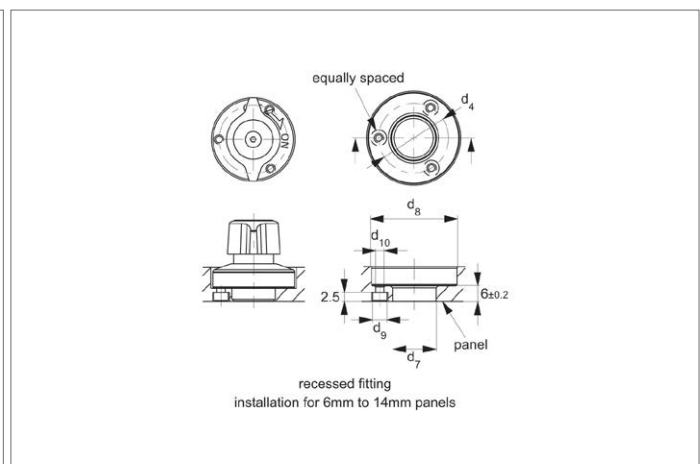
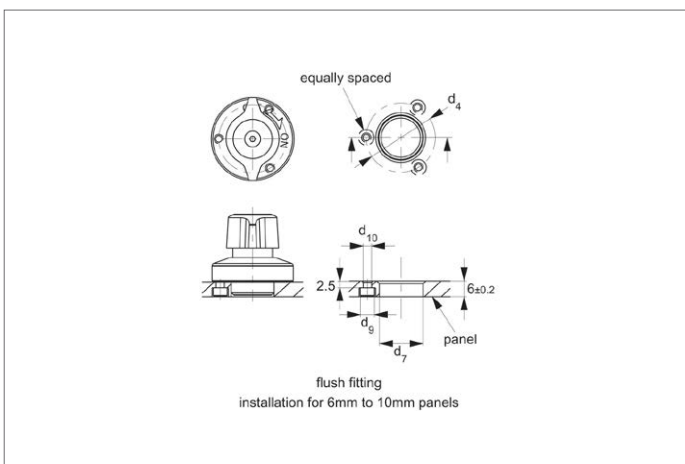



Operating Principle

Four ball bearings clamp onto the clamping pin, the wedge shape of the pin (33929) draws the panels together during clamping.

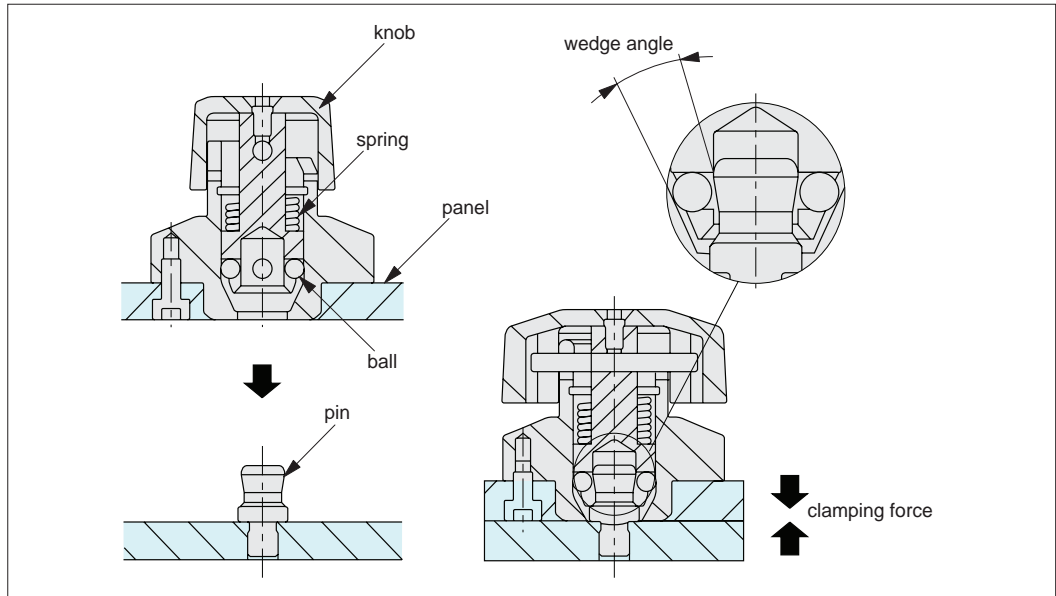

Operating Instructions

- 1 Turn handle to off position to retract the clamping balls. Engage panel and clamp over clamping pin. Turn handle on to position to clamp.
- 2 To unclamp, reverse steps above.

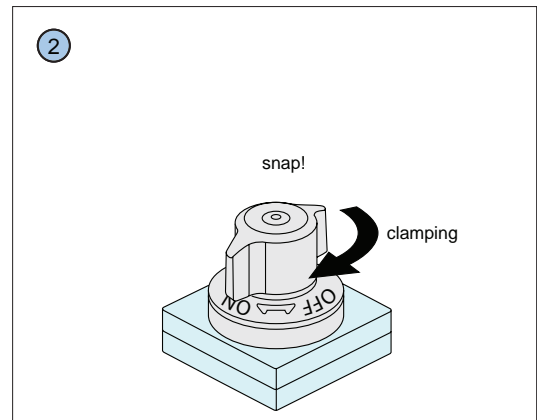
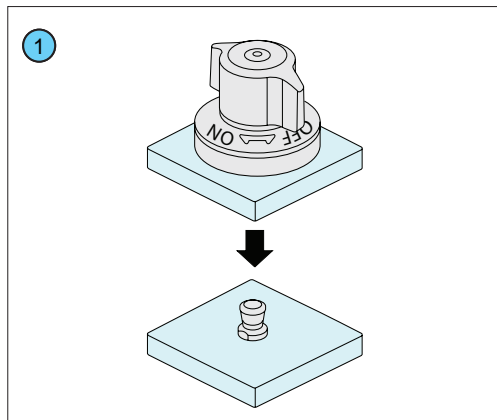

Warning

Rotation of either sub panel or base panel can result in one touch fastener unclamping. When either panel is at risk of rotating ensure a stop is in place.

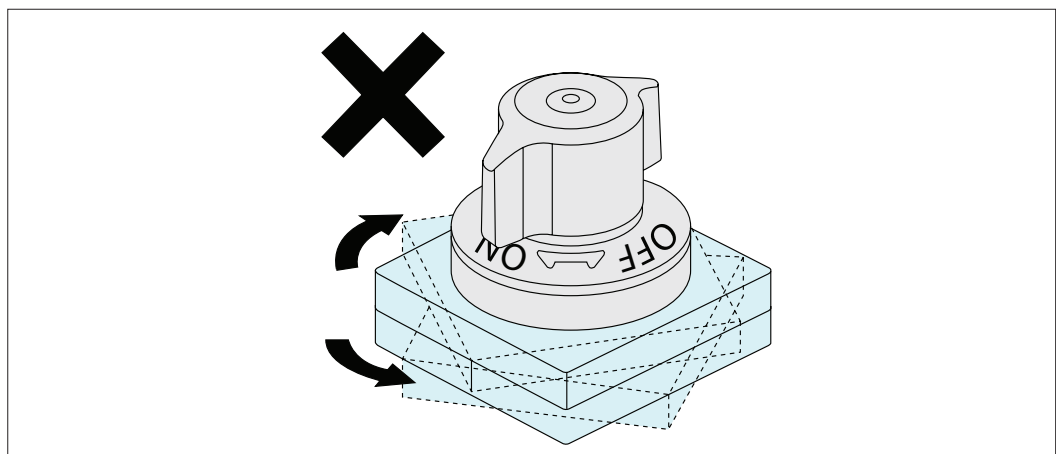



Applications

Changes of Guides Around Star Wheels

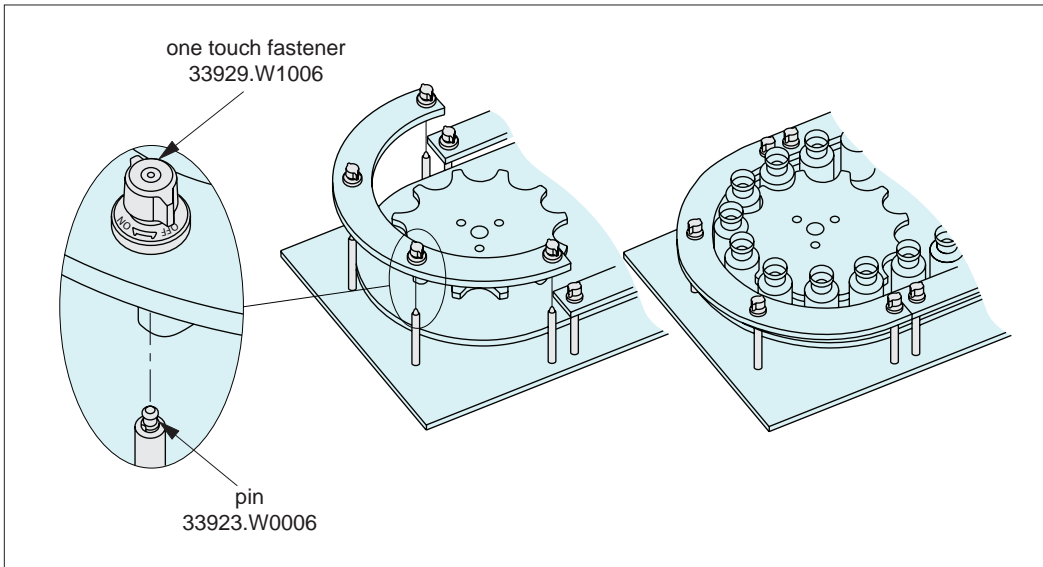

Changes of Suction Grippers for Wafer Handling

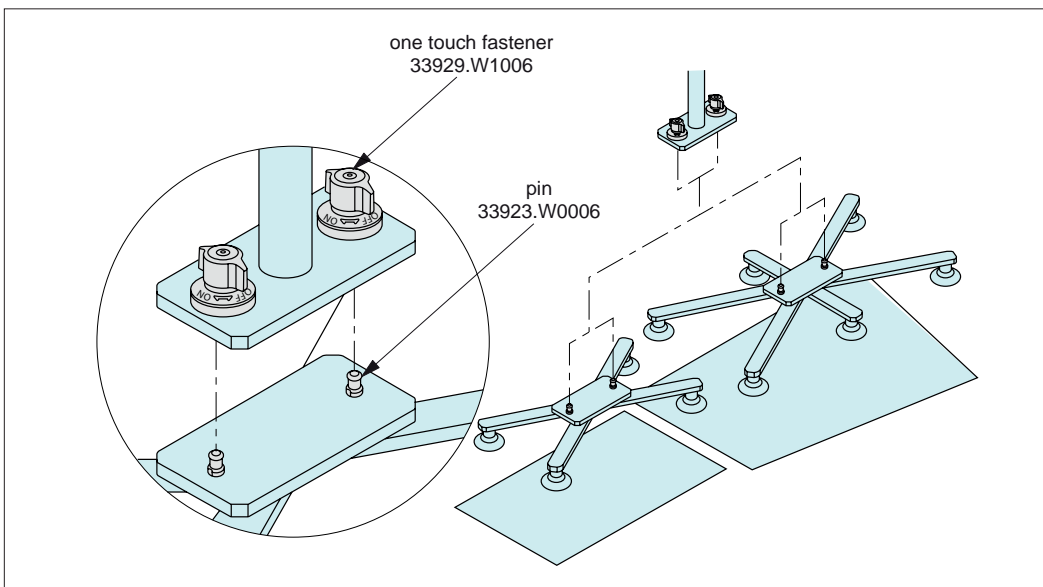



33945

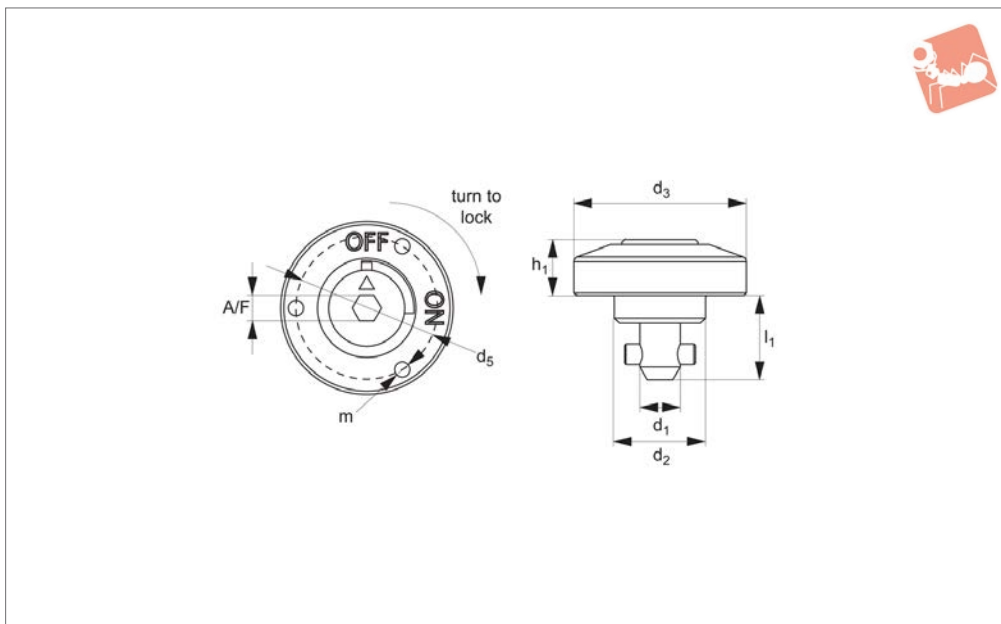

Material

Body: stainless steel SUS303.
Shank: steel, nickel plated.
Pin: stainless SUS 304.

Technical Notes

One-touch fasteners are the ideal solution for applications requiring rapid and recurring change over of tooling or set ups. Use in applications as diverse as bottling processes, machine covers, changing of

cogs and drive belts. One-touch fasteners provide a quick, simple and secure change over solution - no time wasted in unfastening screws or other permanent fixings, and no opportunity for lost fixings in your machinery.
Temperature resistant to 200°C.

Important Notes

Suitable for panels/enclosures of 6 to 20 mm thickness. For locating bushes see part

no. 33948 and 33949.

Actuation:

- Use suitable hex key to turn lock to off position. Present cover panel to frame and align to locking bush.
- With the hex key, now turn the lock back 45° to the on position; locking pin follows, tightening fastener and fastening panel.

Order No.	For single panel thickness	Clamping force N	d ₁ -0.04, -0.08	d ₂ tol. h9	d ₃	l ₁	h ₁	m	Shear strength N	Tensile strength N	A/F	Weight g
33945.W1005	6 - 10	60	5	14	25	15,5	8	M 2x0,4	1800	1200	4	30
33945.W1408	6 - 14	90	8	18	34	17,0	11	M 3x0,5	3200	2600	5	105
33945.W2008	12 - 20	90	8	18	34	23,0	11	M 3x0,5	3200	2600	5	110



One-Touch Fastener - Cam Locking

thin plate locating bush for quarter turn



One Touch Fasteners

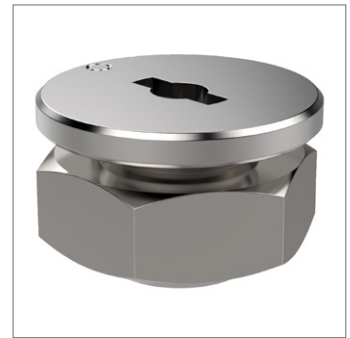
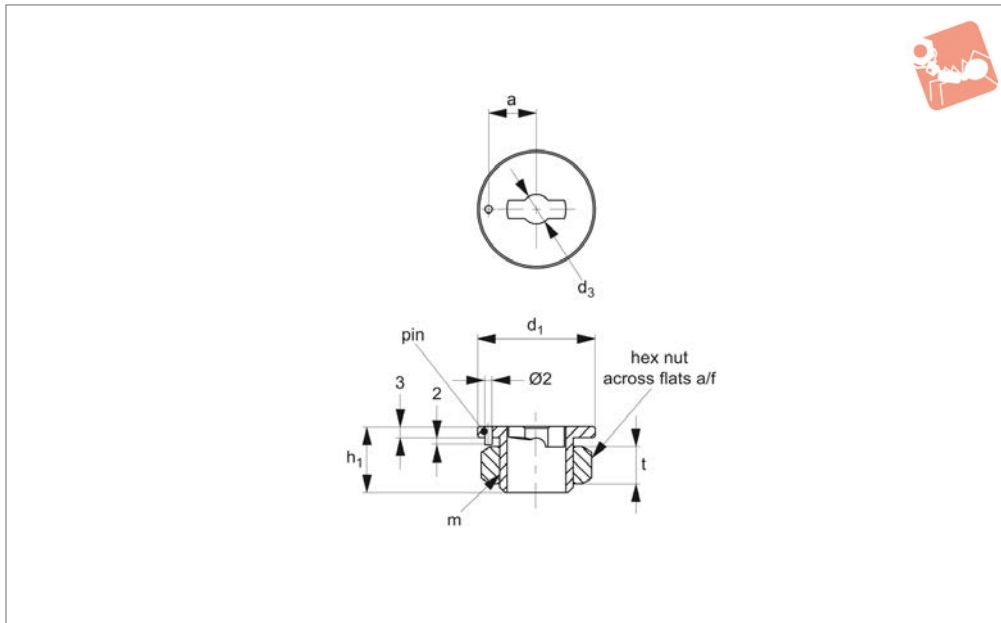

33948

ONE TOUCH FASTENERS

Material

Body: steel, nickel plated or stainless steel.

Nut: stainless steel.

Technical Notes

Used in conjunction with one-touch fasteners 33940 to 33946, locating bushes 33948 provide secure fastening of panels

and covers. Locating bushes are of particular use in soft metals, such as aluminium where receiving surfaces may wear. One-touch fasteners are the ideal solution for applications requiring rapid and recurring change over of tooling or set ups. Use in applications as diverse as bottling processes, machine covers, changing of

cogs and drive belts. Temperature resistant to 200°C.

Important Notes

Suitable for panels/enclosures of 6 to 12 mm thickness. For one-touch fasteners see part nos. 33940 to 33946. For installation instructions see technical page.

Order No.	For single panel thickness	Material	d_1 -0.04 -0.08	d_2	d_3 +0.08 +0.04	d_4 +0.10 +0.05	a ±0.1	l_1	h_1	m	t	A/F	Weight g
33948.W0005	6-10	Steel	25	15	5	25	10,5	3,5	16	M14x1,5	8	22	40
33948.W0008	6-12	Steel	32	21	8	32	13,0	3,5	18	M20x1,5	10	30	55
33948.W0105	6-10	Stainless Steel	25	15	5	25	10,5	3,5	16	M14x1,5	8	22	40
33948.W0108	6-12	Stainless Steel	32	21	8	32	13,0	3,5	18	M20x1,5	10	30	55

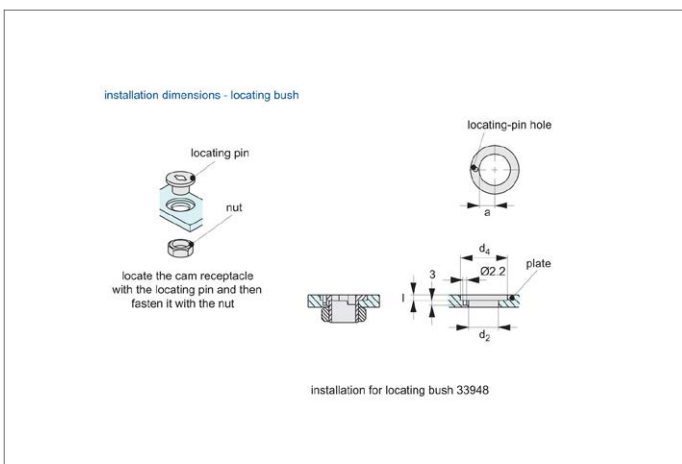



33940

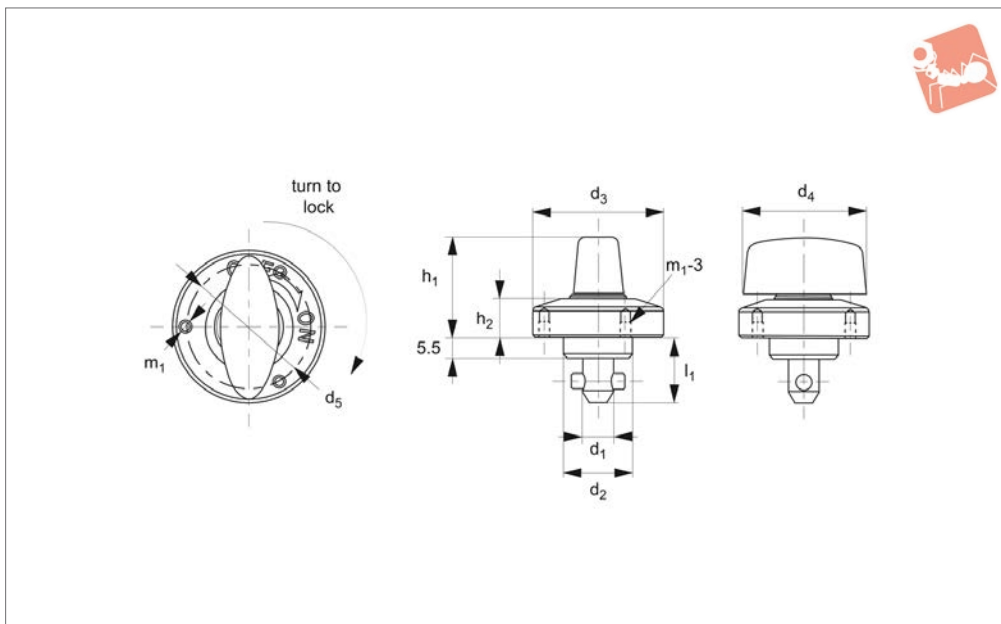

Material

Body: stainless steel SUS303.
Pin: stainless steel.
Knob: polyamide, black.
Spring: steel.

Technical Notes

One-touch fasteners are the ideal solution for applications requiring rapid and recurring change over of tooling or set ups. Use in applications as diverse as bottling

processes, machine covers, changing of cogs and drive belts. One-touch fasteners provide a quick, simple and secure change over solution - no time wasted in unfastening screws or other permanent fixings, and no opportunity for lost fixings in your machinery.
Temperature resistant to 130°C.

Important Notes

Suitable for panels/enclosures of 6 to 20

mm thickness. For locating bushes see part no. 33948 and 33949.

Actuation:

- Turn handle to off position: present cover panel to frame and align to locating bush.
- Turn handle 45° to on position: locking pin follows cam, tightening fastener and securely fastening panel.

Order No.	For single panel thickness	Clamping force N	d_1 -0.04 -0.08	d_2 tol. h9	d_3	d_4	d_5	d_6 +0.10 +0.05	d_7	Weight g
33940.W1005	06-10	60	5	14	25	20	21	14	26	35
33940.W1408	6-14	90	8	18	34	32	28	18	35	105
33940.W2008	12-20	90	8	18	34	32	28	18	35	110

Order No.	d_8	d_9	l_1	m	Shear strength N	Tensile strength N
33940.W1005	4.4	2.4	15.5	M 2x0,4	1800	1200
33940.W1408	4.4	2.4	17.0	M 3x0,5	3200	2600
33940.W2008	6.5	3.4	23.0	M 3x0,5	3200	2600



One-Touch Fastener - Cam Locking

quarter turn - t-handle grip -plastic



One Touch Fasteners

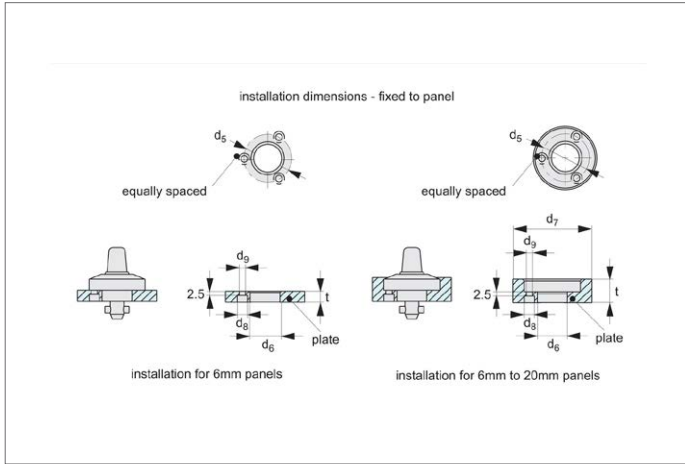

ONE TOUCH FASTENERS



33942

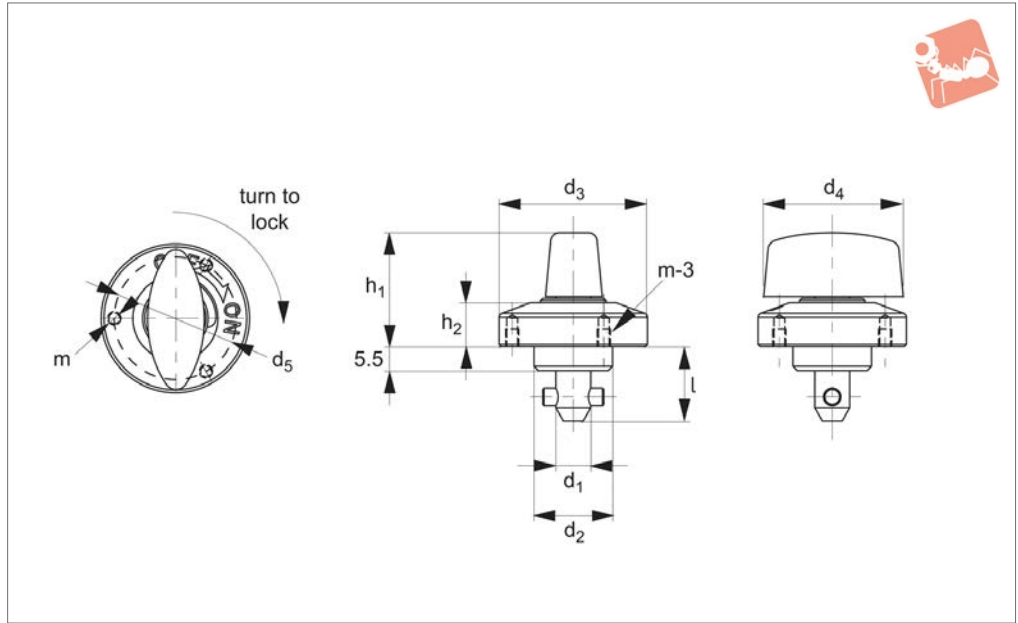

Material

Body, Pin and Knob: SUS303 stainless steel.

Shank: S45C steel nickel plated.
Spring: SWOSC-V steel.

Technical Notes

One-touch fasteners are the ideal solution for applications requiring rapid and recurring change over of tooling or set ups. Use in applications as diverse as bottling

processes, machine covers, changing of cogs and drive belts. One-touch fasteners provide a quick, simple and secure change over solution - no time wasted in unfastening screws or other permanent fixings, and no opportunity for lost fixings in your machinery.
Temperature resistant to 200°C.

Important Notes

Suitable for panels/enclosures of 6 to 20

mm thickness. For locating bushes see part no. 33948 and 33949.

Actuation:

- Turn handle to off position: present cover panel to frame and align to locating bush.
- Turn handle 45° to on position: locking pin follows cam, tightening fastener and securely fastening panel.

Order No.	For single panel thickness	Clamping force N	d ₁ -0.04 -0.08	d ₂ tol. h9	d ₃	d ₄	d ₅	h ₁	h ₂	l	m	Shear strength N	Tensile strength N	Weight g
33942.W1005	6-10	60	5	14	25	20	21	19,0	6,5	15,5	M 2x0,4	1800	1200	40
33942.W1408	6-14	90	8	18	34	32	28	25,5	10,0	17,0	M 3x0,5	3200	2600	130
33942.W2008	12-20	90	8	18	34	32	28	25,5	10,0	23,0	M 3x0,5	3200	2600	135

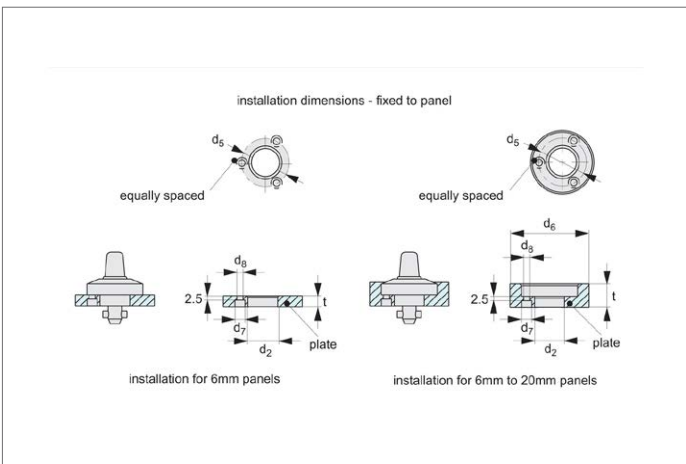



One-Touch Fastener - Cam Locking

quarter turn - t-handle grip - stainless



One Touch Fasteners

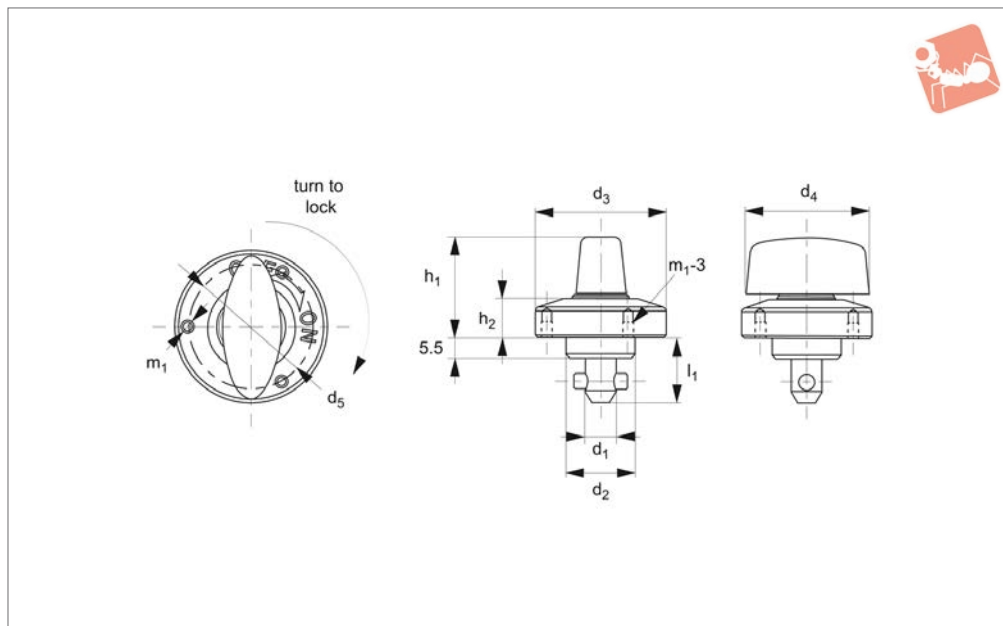

33943

ONE TOUCH FASTENERS

Material

Body and Shank: stainless steel SUS303.
Pin, Knob and Spring: stainless steel SUS304.

Technical Notes

One-touch fasteners are the ideal solution for applications requiring rapid and recurring change over of tooling or set ups. Use in applications as diverse as bottling processes, machine covers, changing of

cogs and drive belts. One-touch fasteners provide a quick, simple and secure change over solution - no time wasted in unfastening screws or other permanent fixings, and no opportunity for lost fixings in your machinery.

Temperature resistant to 200°C.

Important Notes

Suitable for panels/enclosures of 6 to 20 mm thickness. For locating bushes see part

no. 33948 and 33949.

Actuation:

- Turn handle to off position: present cover panel to frame and align to locating bush.
- Turn handle 45° to on position: locking pin follows cam, tightening fastener and securely fastening panel.

Order No.	For single panel thickness	Clamping force N	d ₁ -0.04 - tol. h9 0.08	d ₂	d ₃	d ₄	d ₅	l ₁	h ₁	h ₂	m ₁	Shear strength N	Tensile strength N	Weight g
33943.W1005	6-10	60	5	14	25	20	21	15,5	19	6,5	M 2x0,4	1800	1200	35
33943.W1408	6-14	90	8	18	34	32	28	17,0	26	10,0	M 3x0,5	3200	2600	105
33943.W2008	12-20	90	8	18	34	32	28	23,0	26	10,0	M 3x0,5	3200	2600	110



33944

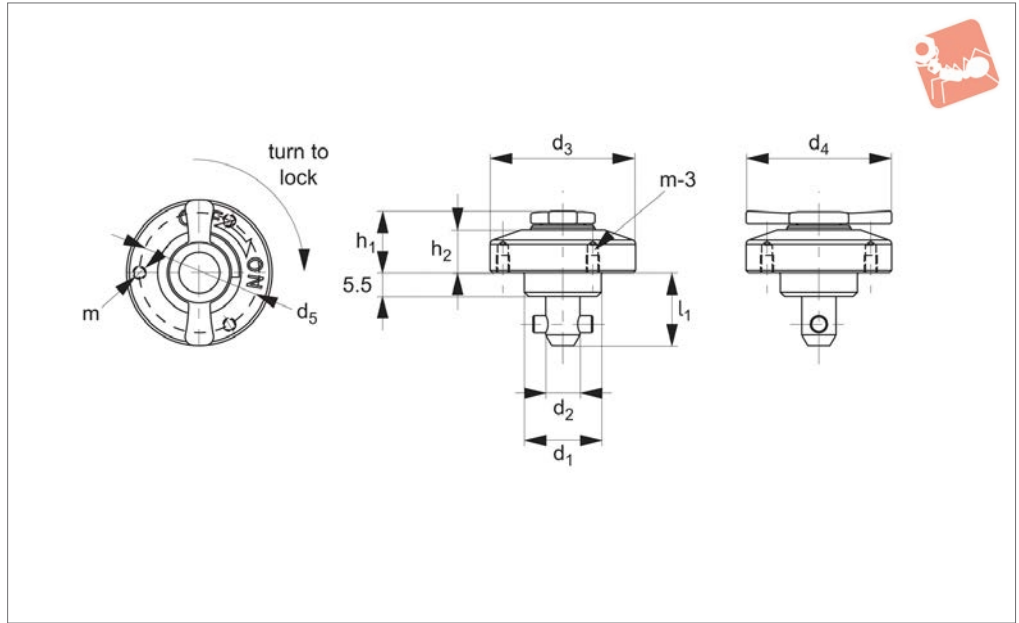

Material

Body and Shank: stainless steel SUS303
Pin, Knob, Spring: stainless steel SUS304.

Technical Notes

One-touch fasteners are the ideal solution for applications requiring rapid and recurring change over of tooling or set ups. Use in applications as diverse as bottling processes, machine covers, changing of

cogs and drive belts. One-touch fasteners provide a quick, simple and secure change over solution - no time wasted in unfastening screws or other permanent fixings, and no opportunity for lost fixings in your machinery. Temperature resistant to 200°C.

Important Notes

Suitable for panels/enclosures of 6 to 20

mm thickness. For locating bushes see part no. 33948 and 33949.

Actuation:

- Turn handle to off position: present cover panel to frame and align to locating bush.
- Turn handle 45° to on position: locking pin follows cam, tightening fastener and securely fastening panel.

Order No.	For single panel thickness	Clamping force N	d ₁ -0.04 - tol. h9 0.08	d ₂	d ₃	d ₄	d ₅	l ₁	h ₁	h ₂	m	Shear strength N	Tensile strength N	Weight g
33944.W1005	6-10	60	5	14	25	25	21	15,5	11,5	6,5	M 2x0,4	1800	1200	35
33944.W1408	6-14	90	8	18	34	34	28	17,0	14,0	10,0	M 3x0,5	3200	2600	80
33944.W2008	12-20	90	8	18	34	34	28	23,0	14,0	10,0	M 3x0,5	3200	2600	85

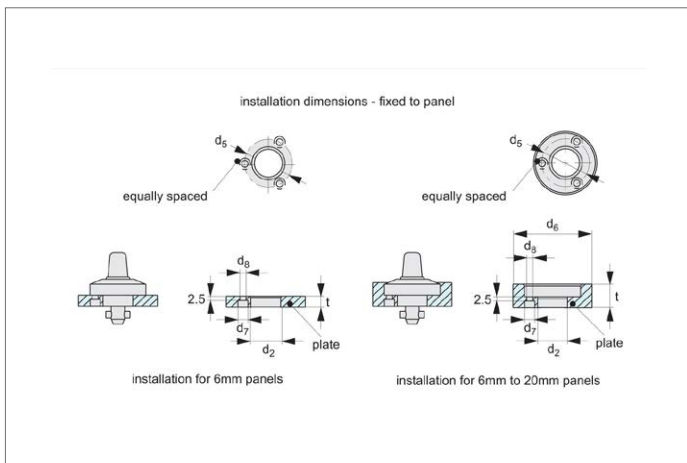



One-Touch Fastener- Cam Locking

retract - quarter turn - t-handle grip - plastic



One Touch Fasteners

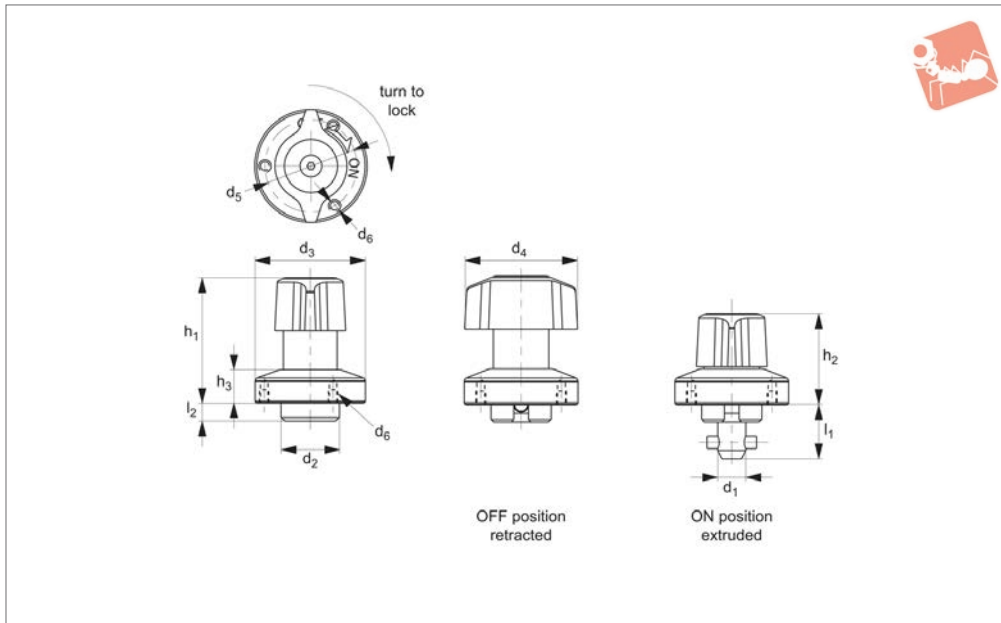

33946

ONE TOUCH FASTENERS

Material

Body: steel, nickel plated.
Shank: steel, nickel plated.
Pin: stainless steel, SUS304.
Knob: polyamide, black.
Spring: stainless steel.

Technical Notes

One-touch fasteners are the ideal solution for applications requiring rapid and recurring change over of tooling or set ups. Use in applications as diverse as bottling processes, machine covers, changing of cogs and drive belts. One-touch fasteners

provide a quick, simple and secure change over solution - no time waste in unfastening screws or other permanent fixings, and no opportunity for lost fixings in your machinery.
Temperature resistant to 130°C.

Important Notes

One-touch fastener offers full retraction of clamping shank when part is unlocked, this offer's the benefit of enabling panels to be slid into position - especially useful with larger or oversized panels, and enables its use on sliding or linear rail applications to provide positive location

and clamping of parts.

Actuation:

- Turn handle to off position, and ensure the shank is fully retracted.
- Place or slide the over in place and position over the locating bush.
- Turn handle to on position for clamping, an audible click is heard when fully clamped.
- To release, turn handle back to off position, the shank is fully retracted into clamp body assisted by the return spring.

Order No.	Single panel thickness	Clamping force N	d ₁	d ₂	d ₃	d ₄	d ₅	d ₆	l ₁	l ₂	h ₁	h ₂	h ₃	Shear strength N	Tensile strength N	Weight g
33946.W1005	6-10	60	5	14	25	25	21	M 2x0,4	15,5	5,5	30	20,0	6,5	1800	1200	40
33946.W1408	6-14	90	8	18	34	34	28	M 3x0,5	17,0	5,5	38	36,5	10,0	3200	400	100



33947

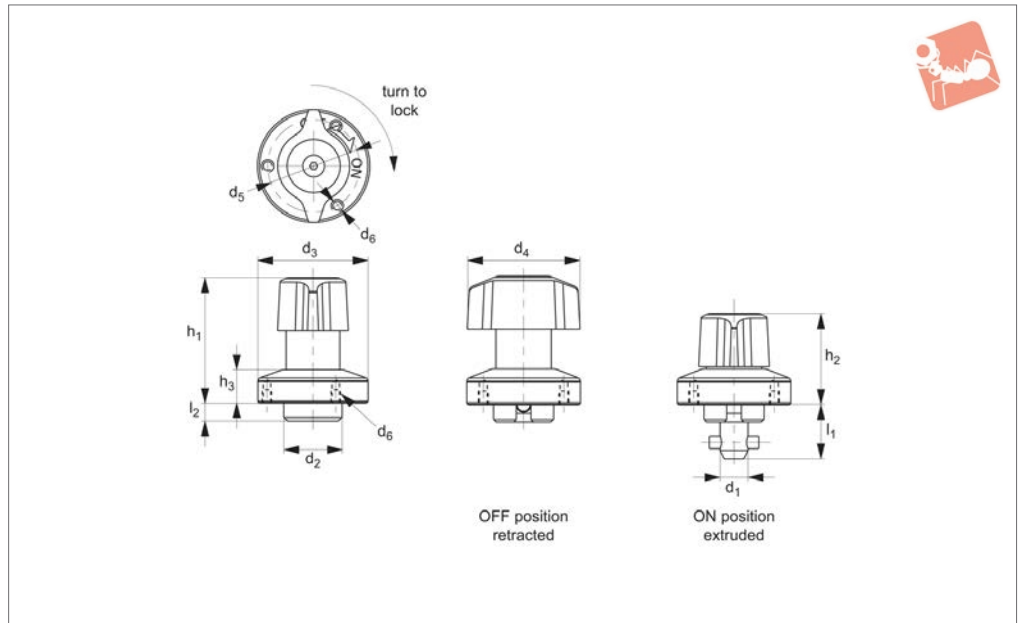

Material

Body: steel, nickel plated.
 Shank: steel, nickel plated.
 Pin: stainless steel, SUS304.
 Knob: stainless steel, SUS304.
 Spring: stainless steel.

Technical Notes

One-touch fasteners are the ideal solution for applications requiring rapid and recurring change over of tooling or set ups. Use in applications as diverse as bottling processes, machine covers, changing of cogs and drive belts. One-touch fasteners

provide a quick, simple and secure change over solution - no time waste in unfastening screws or other permanent fixings, and no opportunity for lost fixings in your machinery.
 Temperature resistant to 200°C.

Important Notes

One-touch fastener offers full retraction of clamping shank when part is unlocked, this offer's the benefit of enabling panels to be slid into position - especially useful with larger or oversized panels, and enables its use on sliding or linear rail applications to provide positive location

and clamping of parts.

Actuation:

- Turn handle to off position, and ensure the shank is fully retracted.
- Place or slide the over in place and position over the locating bush.
- Turn handle to on position for clamping, an audible click is heard when fully clamped.
- To release, turn handle back to off position, the shank is fully retracted into clamp body assisted by the return spring.

Order No.	Single panel thickness	Clamping force N	d ₁	d ₂	d ₃	d ₄	d ₅	d ₆	l ₁	l ₂	h ₁	h ₂	h ₃	Shear strength N	Tensile strength N	Weight g
33947.W1005	6-10	60	5	14	25	25	21	M2x0,4	15,5	5,5	30	20,0	6,5	1800	1200	40
33947.W1408	6-14	90	8	18	34	34	28	M3x0,5	17,0	5,5	38	26,5	10,0	3200	400	100



Operating Principle

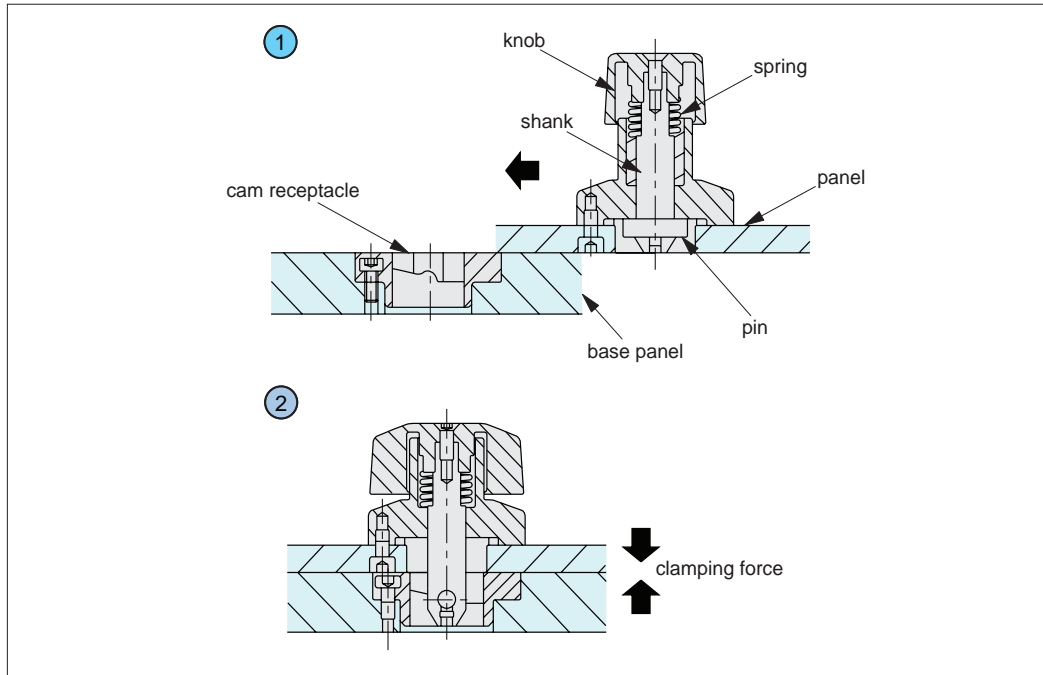

- 1 The shank retracts at the unclamping position to enable operations without interference with the base panel.
- 2 When the pin contacts along the cam surface in the cam receptacle, the spring gets compressed to press down the panel.

ONE TOUCH FASTENERS

Operating Instructions

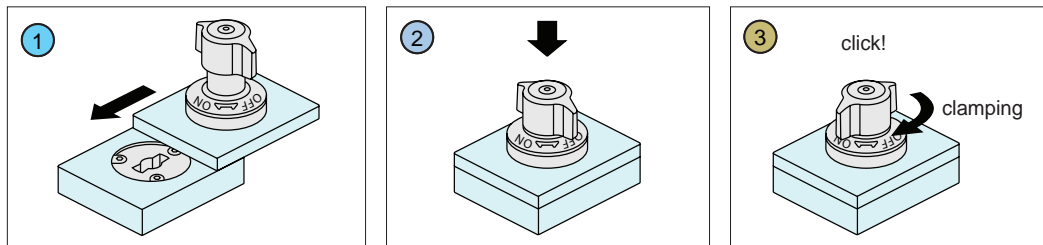

- 1 Ensure that the knob is positioned at the "OFF" mark and the pin is retracted.
- 2 Locate the cam receptacle directly under the fastener. Insert retracted pin by pressing the knob down.
- 3 Turn the knob to the "ON" mark for clamping. The knob clicks when clamped. Turning the knob to the "OFF" position, the pin returns automatically to the unclamping position.

ov-W33946-A-T-W33947-A-T-cam-locking-retract-overview-a-rmh - Updated - 28-10-2022



Applications

Changes of
Fixture Plates

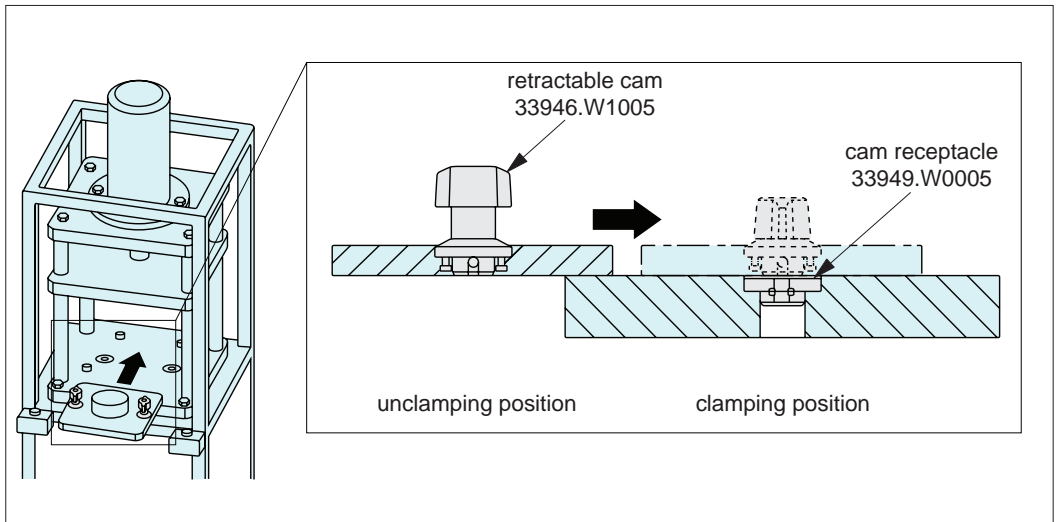

Lock for Doors

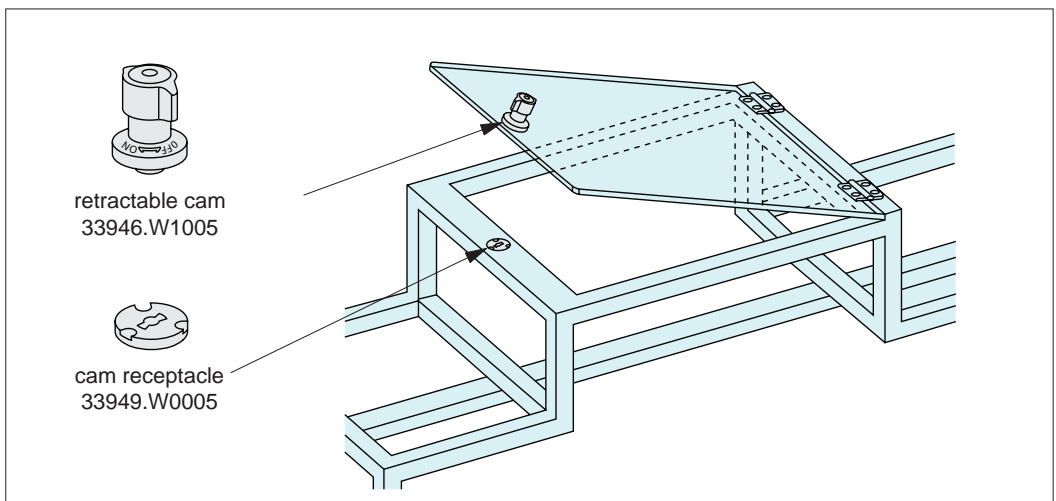

Adjustment of
Workpiece Guides

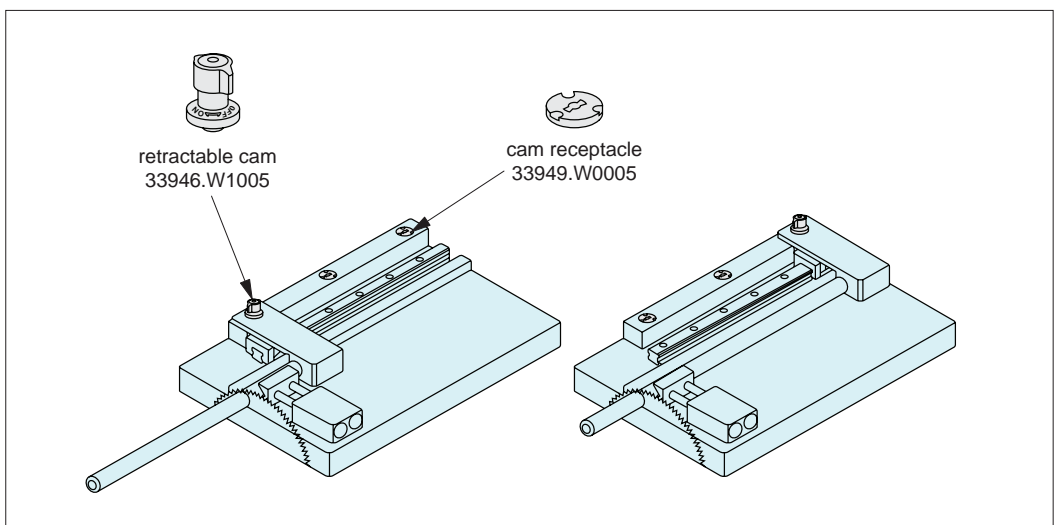



Installation Dimensions

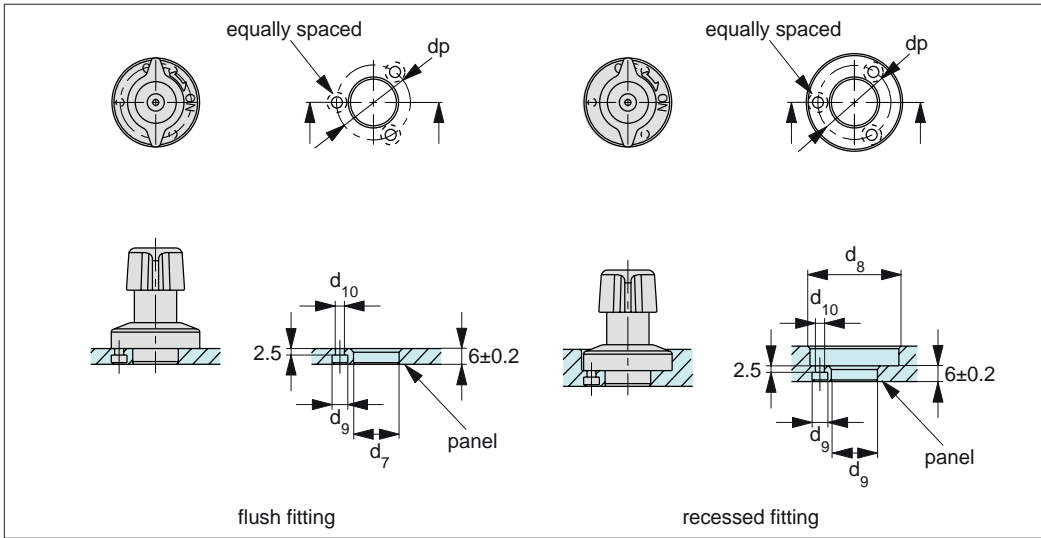

Installation Best Practice

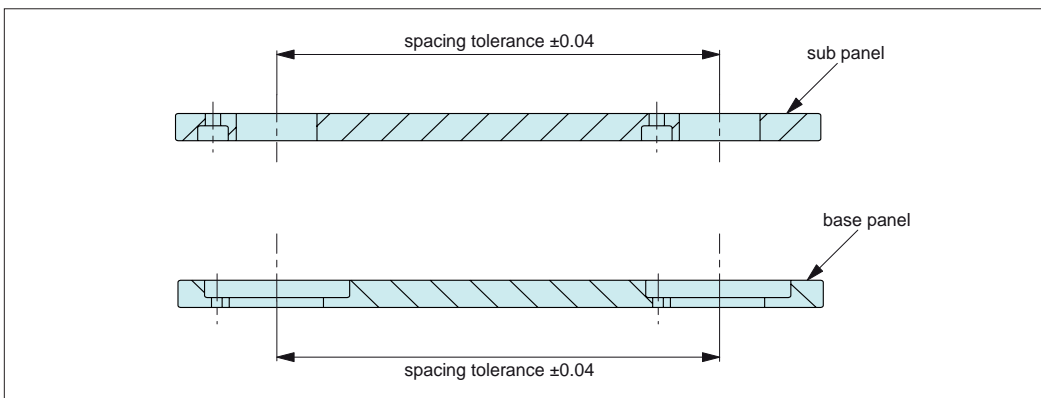

Machining Accuracy

Spacing tolerance on both the sub panel and the base panel should be ± 0.04 .

Repeatability

For highly accurate locating, use locating pins 36340 or 36341. Repeatability of ± 0.1 is achievable.

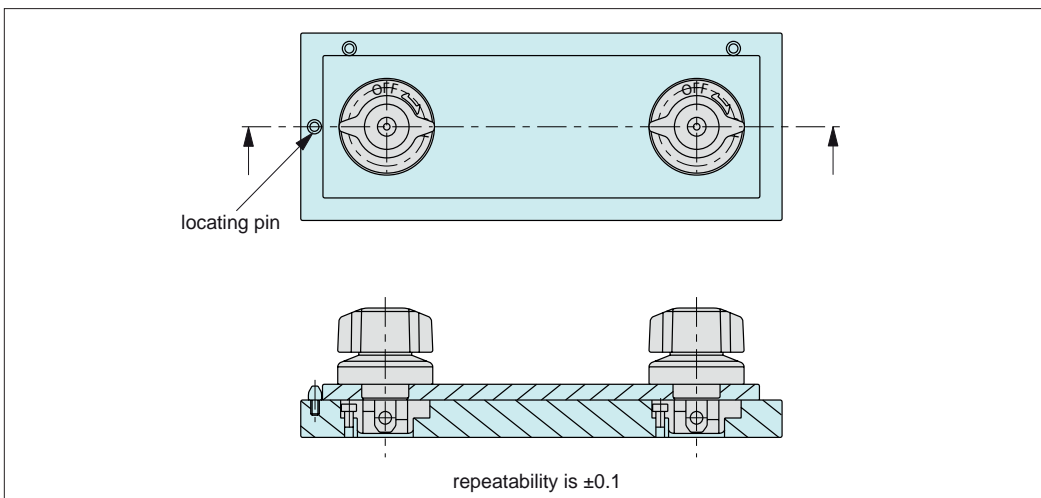



33949

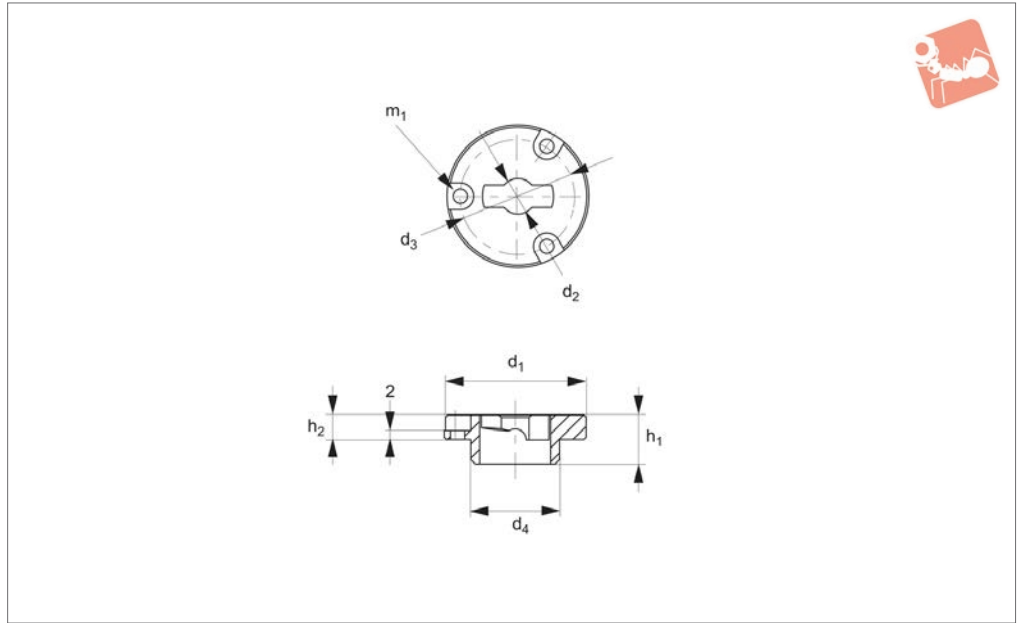

Material

Body: steel, nickel plated or stainless steel.

Technical Notes

Used in conjunction with one-touch fasteners 33940 to 33946, locating bushes 3394820 provide secure fastening of panels and covers. Locating bushes are of

particular use in soft metals, such as aluminium where receiving surfaces may wear. One-touch fasteners are the ideal solution for applications requiring rapid and recurring change over of tooling or set ups. Use in applications as diverse as bottling processes, machine covers, changing of cogs and drive belts.

Temperature resistant to 200°C.

Important Notes

Suitable for panels/enclosures of 6 to 12 mm thickness. For one-touch fasteners see part nos. 33940 to 33946. For installation instructions see technical page.

Order No.	For single panel thickness	Material	d ₁	d ₂	d ₃	d ₄ -0.04 -0.08	d ₆	d ₇	l ₁	l ₂	h ₂	m ₁	m ₂	Weight g
33949.W0005	>10	Steel	25	5	21	14	26	14	5	4	4,5	M 2	M 2x0,4	20
33949.W0008	>12	Steel	32	8	26	20	33	20	6	5	5,5	M 3	M 3x0,5	35
33949.W0105	>10	Stainless Steel	25	5	21	14	26	14	5	4	4,5	M 2	M 2x0,4	20
33949.W0108	>12	Stainless Steel	32	8	26	20	33	20	6	5	5,5	M 3	M 3x0,5	35

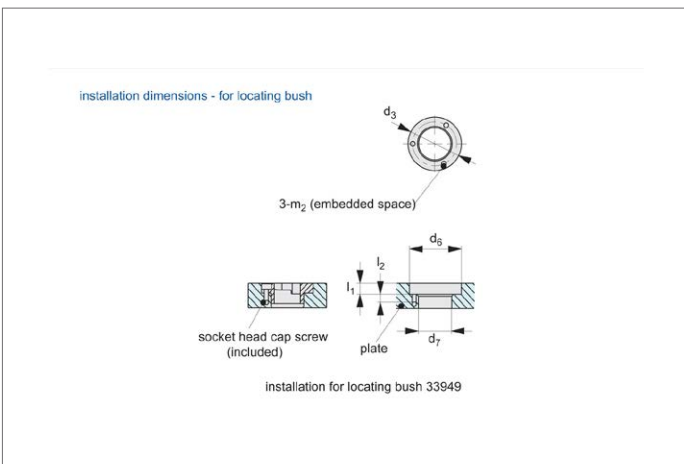

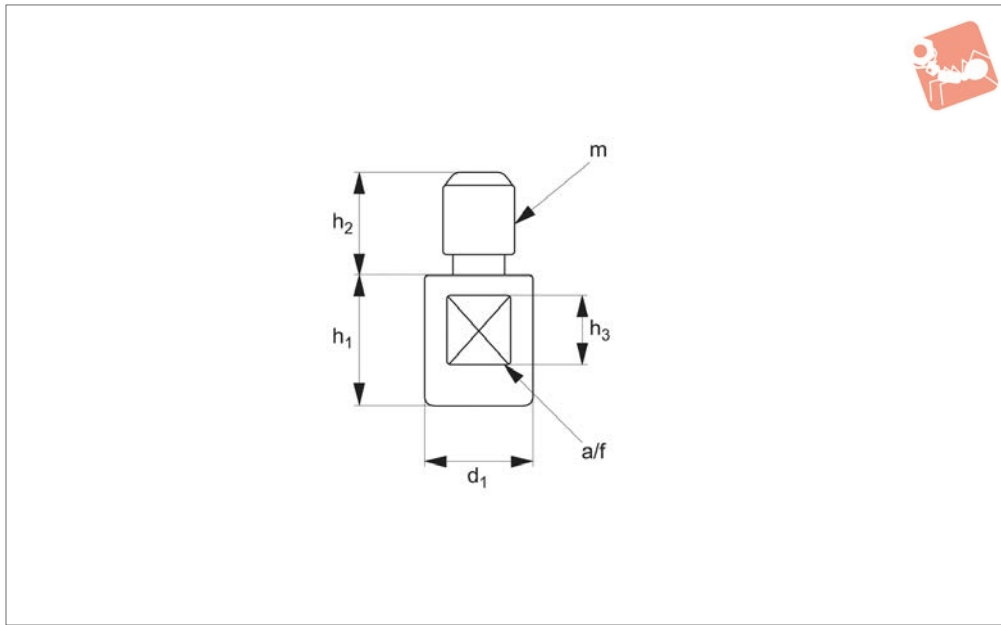

33950

ONE TOUCH FASTENERS

Material

Body: steel, nickel plated.

Technical Notes

Used in conjunction with magnetic one-touch fasteners 33956, provides secure fastening of panels and covers. One-touch fasteners are the ideal solution for applica-

tions requiring rapid and recurring change over of tooling or set ups. Use in applications as diverse as bottling processes, machine covers, changing of cogs and drive belts.

Note: pin itself is not magnetic, it is for use with locating bush part no. 33956,

which contains magnet.

Important Notes

Suitable for panels/enclosures of 2 to 6 20 mm thickness.

For installation instructions see technical page.

Order No.	For single panel thickness	d_1	h_1	h_2	h_3	m	A/F	Shear strength N	Weight g
33950.W0006	2 to 6	$-0.02 -0.04$ Ø6	7	5.8	4	M 4x0,7	5	900	2

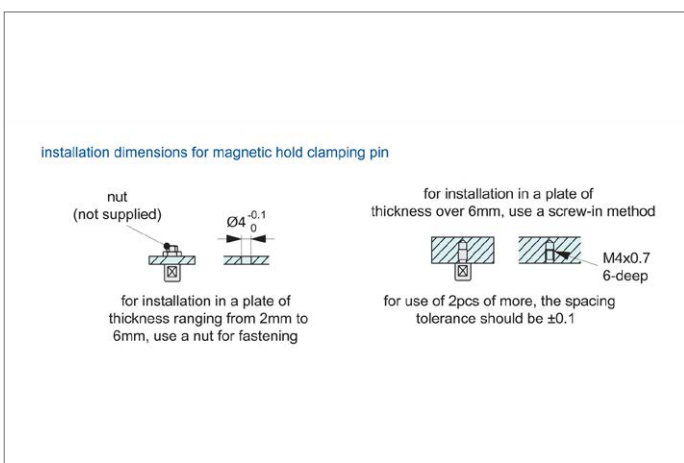



33956

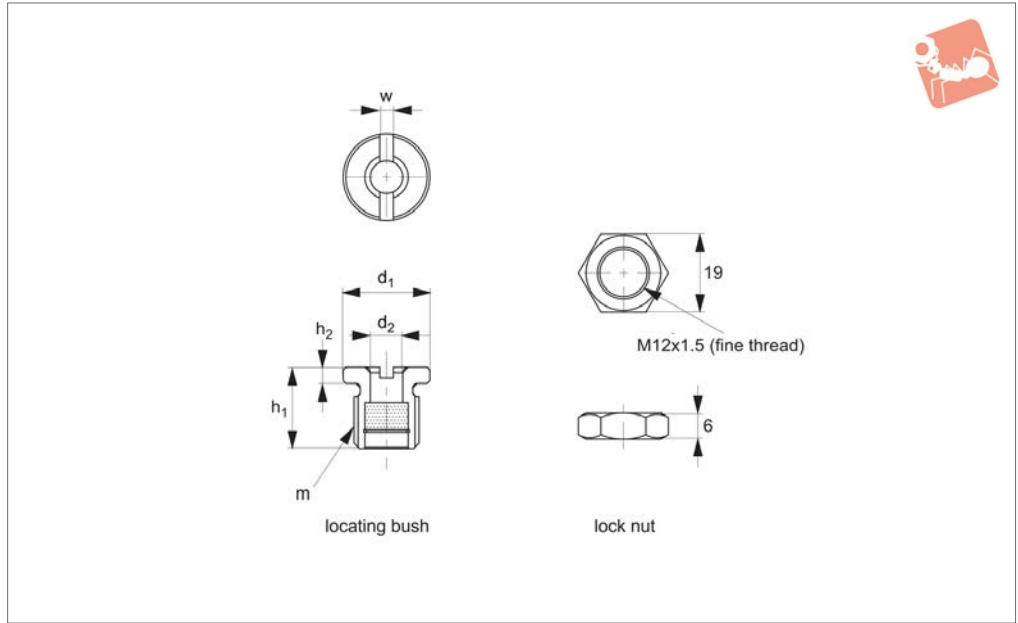

Material

Body: stainless steel.
Magnet: neodymium.

Technical Notes

One-touch fasteners are the ideal solution for applications requiring rapid and recurring change over of tooling or set ups. Use in applications as diverse as bottling processes, machine covers, changing of cogs and drive belts. One-touch fasteners

provide a quick, simple and secure change over solution - no time waste in unfastening screws or other permanent fixings, and no opportunity for lost fixings in your machinery.

Important Notes

Suitable for panels/enclosures of 2 to 6 mm thickness. For pin see part no. 33950. Part contains Neodymium magnets which in conjunction with one-touch pin no.

33950 creates a magnetic clamping force of 7 N.

Actuation:

Engage pin into receiver, magnetic effect will take hold. Panels are securely fastened.

To release, simply pull panels apart with sufficient force to overcome magnetic holding force, panel is released.

Order No.	For single panel thickness	Type	d_1 tol. h9	d_2 +0.10 +0.05	h_1	h_2	m	w	Clamping force N	Weight g
33956.W0076	2 to 6mm	Bush	Ø16	Ø6	15	3	M12x1,5	2.5	7	12

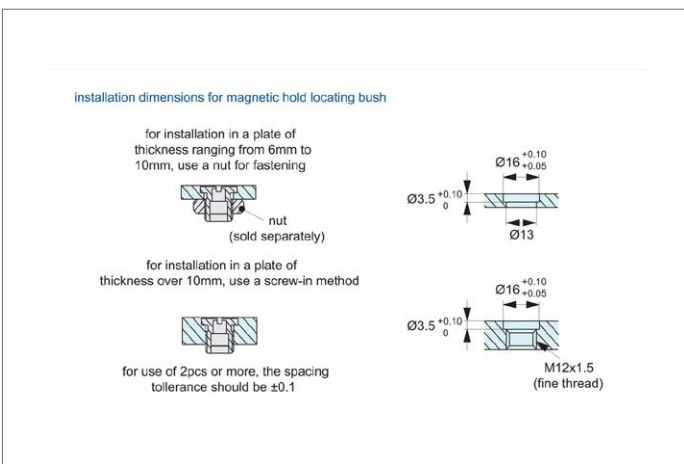

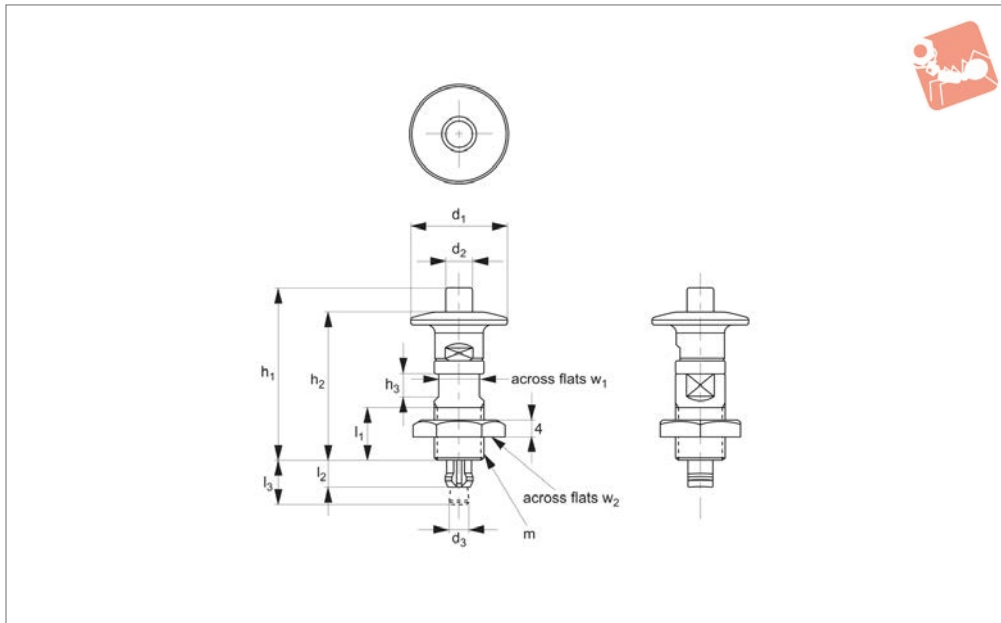

33960

ONE TOUCH FASTENERS

Material

Stainless steel.

Order No.	d	d ₁	d ₂	h	h ₁	h ₂	l	l ₁	l ₂	m	w	w ₁	Clamping force N	Shear strength	Tensile strength	Proper base plate thickness	Proper plate thickness	Weight g
33960.W6123	6,5	23	6,5	40	32	5,5	12,5	6,5	10,5	M12x1 (Fine thread)	10	19	3	200	150	3	3~8	41
33960.W6126	6,5	23	6,5	37	29	5,5	12,5	6,5	13,5	M12x1 (Fine thread)	10	19	3	200	150	6	3~8	40
33960.W8123	8,5	32	10	51	41,5	7	16,5	6,5	11	M16x1 (Fine thread)	14	24	6	400	300	3	3~12	88
33960.W8126	8,5	32	10	48	38,5	7	16,5	9,5	14	M16x1 (Fine thread)	14	24	6	400	300	6	3~12	88



33964

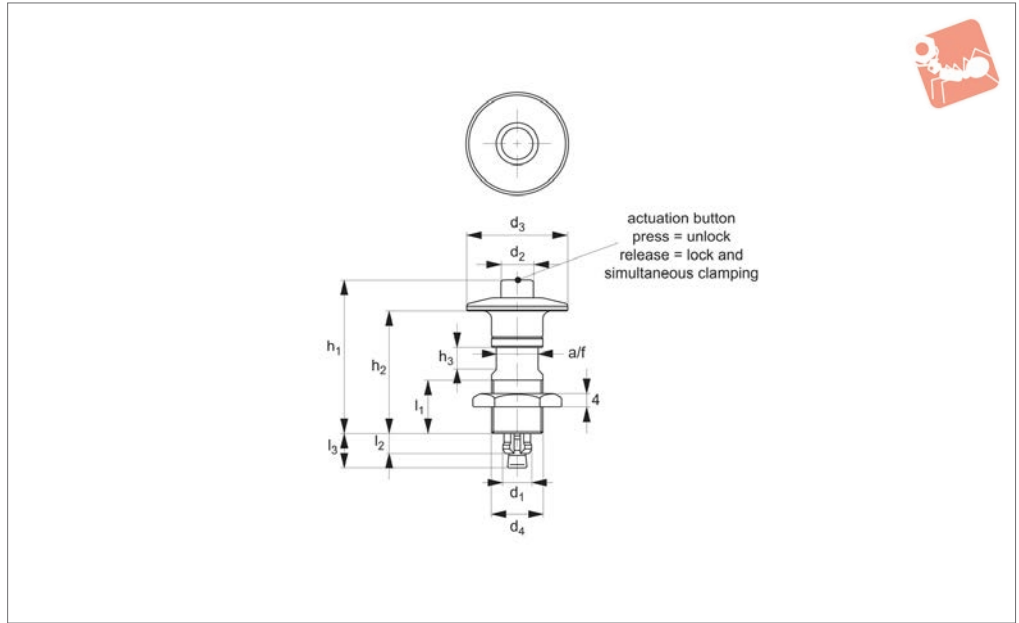

Material

Body: stainless steel SUS 303.
 Spacer: stainless steel SUS 303.
 Spring: stainless steel SUS 303.

Technical Notes

One-touch fasteners are the ideal solution for applications requiring rapid and recurring change over of tooling or set ups. Use in applications as diverse as bottling processes, machine covers, changing of cogs and drive belts. One-touch fasteners provide a quick, simple and secure change over solution - no time waste in unfaste-

ning screws or other permanent fixings, and no opportunity for lost fixings in your machinery.

Tips

For highly accurate locating, use locating pins 36340 and 36341.

Important Notes

Suitable for panels/enclosures of 3 to 12 mm.
 Unique locking and simultaneous clamping.

Actuation:

- While depressing the actuation button, align pin to receiving hole in frame.
- Once pin is aligned seated in the receiving hole, release button.
- Pin will retract, forcing clamping wedges to spread and pull the two panels together to securely fasten.
- To release, reverse steps described above.

Order No.	Single panel thickness mm	Receiver panel thickness	d ₁	d ₂	d ₃	d ₄	A/F	h ₁	Weight g
33964.W0803	3-8	3	6.5	6.5	23	M12x1	10	40	41
33964.W0806	3-8	6	6.5	6.5	23	M12x1	10	37	40
33964.W1203	3-12	3	8.5	10.0	32	M16x1	14	51	88
33964.W1206	3-12	6	8.5	10.0	32	M16x1	14	48	86

Order No.	h ₂	h ₃	l ₁	l ₂	l ₃	Clamping force N	Shear strength N	Tensile strength N
33964.W0803	32.0	5.5	12.5	6.5	10.5	3	200	150
33964.W0806	29.0	5.5	12.5	9.5	13.5	3	200	150
33964.W1203	41.5	7.0	16.5	6.5	11.0	6	400	300
33964.W1206	38.5	7.0	16.5	9.5	14.0	6	400	300



One-Touch Fastener - Pull Clamping

push button lock - button handle - stainless steel



One Touch Fasteners

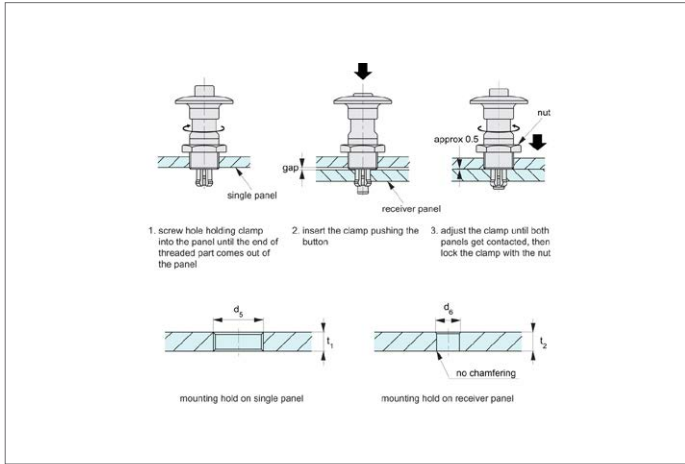



Operating Principle

- 1 The tapered pin expanded by the wedge pushes out against the edge of the hole on the base panel, and the two panels are clamped.
- 2 Just a tapped hole and a through hole are required.

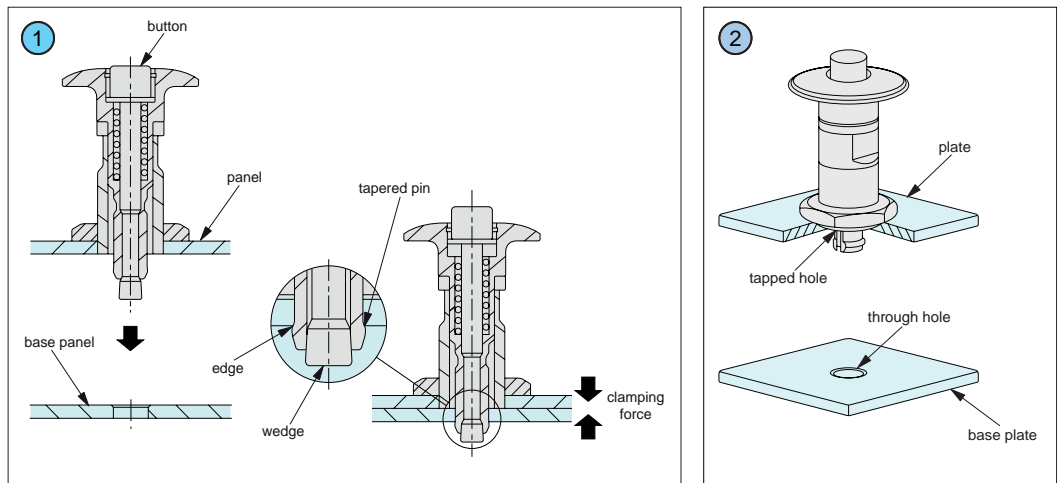

Operating Instructions

- 1 While depressing the actuation button, align the pin to receiving hole.
- 2 Once pin is aligned and seated in the receiving hole, release button. Pin will retract, forcing clamping wedges to spread and pull the two panels together to securely fasten.
- 3 To release, reverse steps described above.

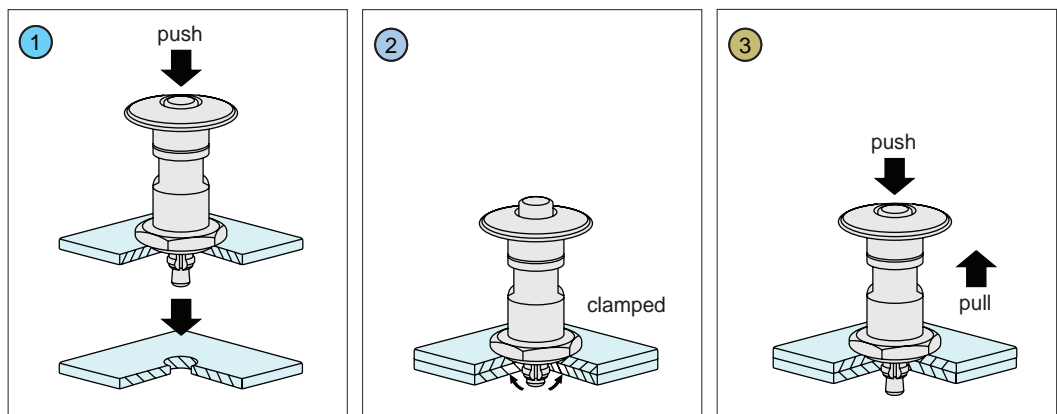

Installation Dimensions

- 1 Screw hole holding clamp into the panel until the end of threaded part comes out of the panel.
- 2 Insert the clamp pushing the button.
- 3 Adjust the clamp until the both panels get contracted and then lock the clamp with the nut.

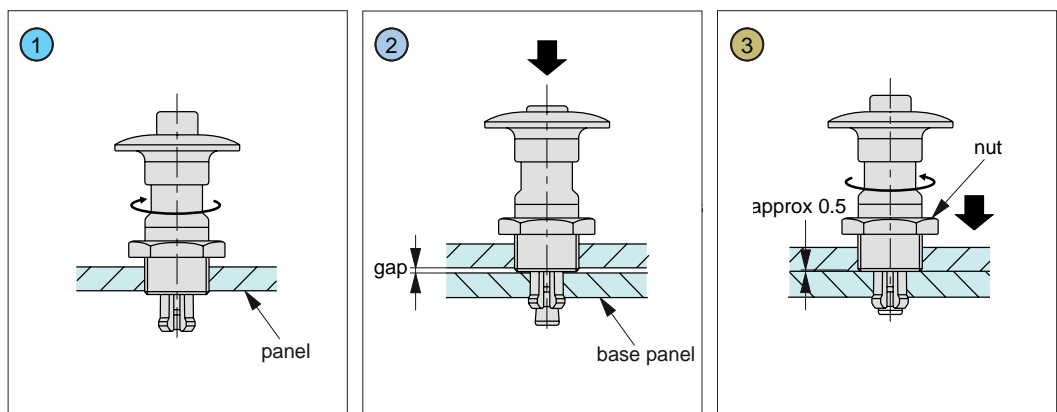



Mounting Hole on Panel

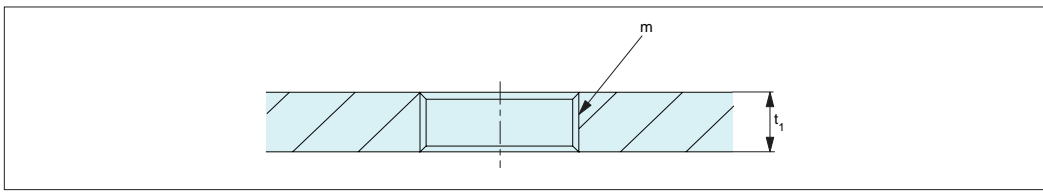

Mounting Hole on Base Panel

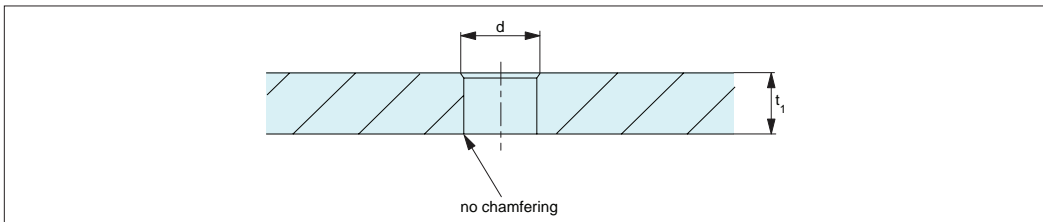

Use hard metals such as stainless steels for the base panel.

Applications

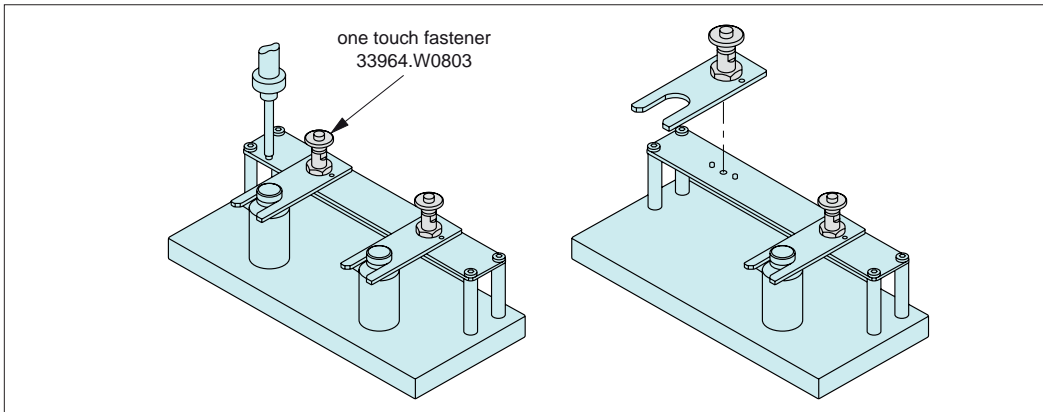

Changes of Holder Panel

Installation Best Practice

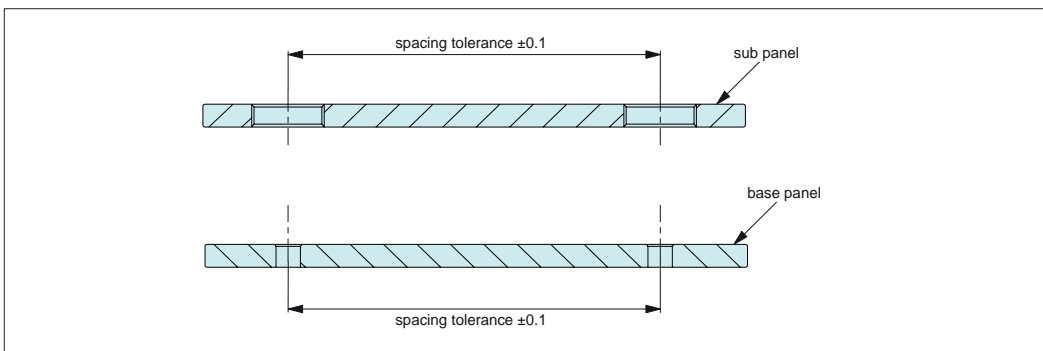

Machining Accuracy

Spacing tolerance on both the sub panel and the base panel should be ± 0.1 .

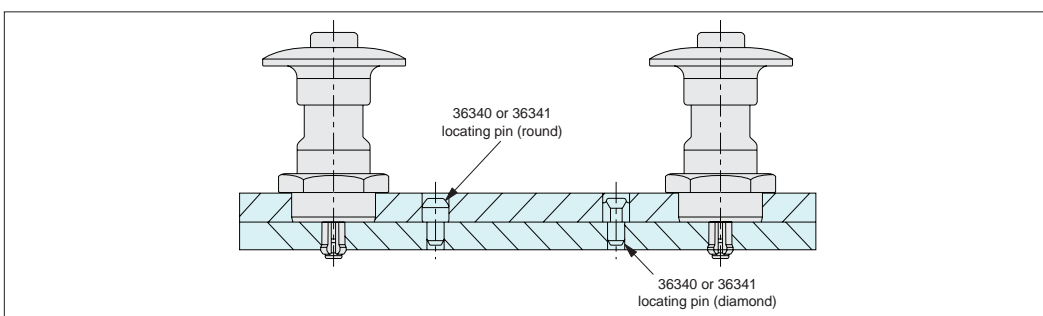

Repeatability

For highly accurate locating, use locating pins 36340 or 36341. Repeatability of ± 0.25 is achievable.

ov-W33964-A-T-pull-clamping-overview-b-rnh - Updated - 28-10-2022



33970

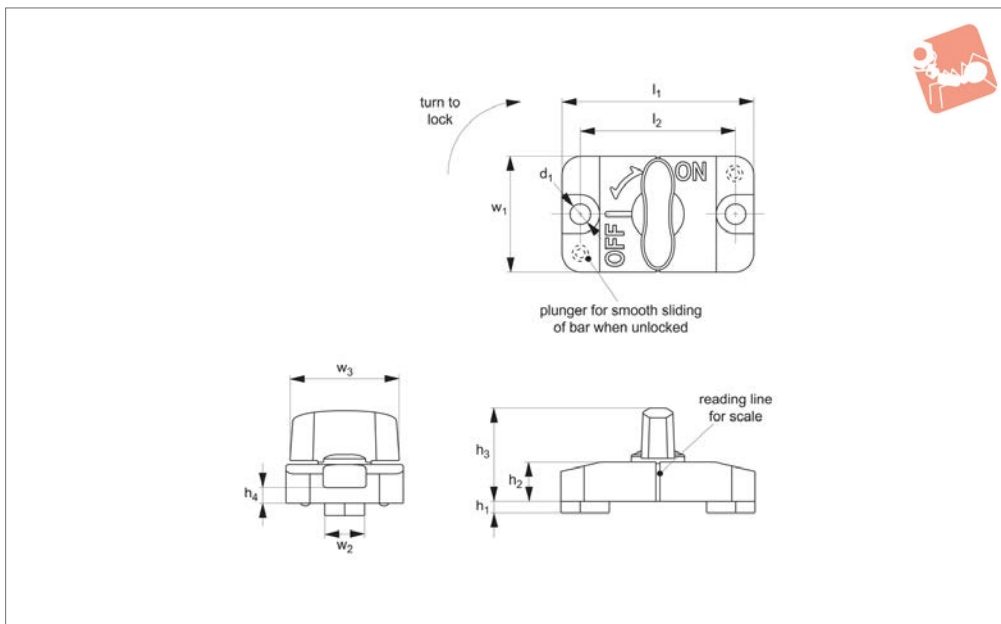

Material

Body: die-cast zinc, chrome plated.
 Grip: polyamide plastic (black or orange), or stainless steel SUS304.
 Clamping shaft/wedge: stainless steel.
 Ball plunger: polyacetal.

Technical Notes

Sliding clamps are ideal for the quick positioning, locking, releasing and re-positioning of sliding bars in many applications. When additionally used with a scale plate (see part no. 33975, 33976 and 33977), the reading line on the sliding clamp enables quick, easy and accurate alignment.

The sliding clamp is mounted, for greater stability, in a fixed position in an assembly. With the clamp set to its off position the

sliding bar (not supplied) can be moved left or right, with two spring loaded ball plungers provide for free movement of bar. Once in its desired position the sliding bar can be locked in place, through a 90 degree turn of the sliding clamp's handle which engages the clamp's clamping shaft/wedge.

Please see technical diagram below for recommended machining details for your sliding bar (not supplied). Riser plates can be used to provide clearance between sliding bar and mounting surface to improve free running of sliding bar, see part no. 33971.

Temperature resistance up to 90°C.
 Max. static load up to 500N - please refer to performance graph below.

Important Notes

Sliding clamps are suited only to straight linear movement of sliding bar (not supplied), and do not tolerate any other applied loads.

Displacement of sliding bar, through repetitive use, will increase if excessive shock or vibration is present. Do not use sliding clamp in vertical applications where vibration is present.

Displacement will also increase with adhesion or immersion of oil or other foreign substances.

Ensure sliding bar is not bent nor warped as this may cause the sliding bar to slip even when sliding clamp is in its on position.

Order No.	For slot width	Handle	Slot depth min.	d ₁	h ₁	h ₂	h ₃	h ₄	Weight g
33970.W0103	10	Plastic, Orange	3	5.5	3	10	24	4.5	80
33970.W0106	10	Plastic, Orange	6	5.5	6	10	24	4.5	80
33970.W1103	10	Plastic, Black	3	5.5	3	10	24	4.5	80
33970.W1106	10	Plastic, Black	6	5.5	6	10	24	4.5	80
33970.W2103	10	Stainless	3	5.5	3	10	24	4.5	95
33970.W2106	10	Stainless	6	5.5	6	10	24	4.5	95

Order No.	l ₁	l ₂	w ₁	w ₂ 0 -0.05	w ₃	Static load N max.
33970.W0103	50	40	30	10	28	500
33970.W0106	50	40	30	10	28	500
33970.W1103	50	40	30	10	28	500
33970.W1106	50	40	30	10	28	500



Sliding Clamps - for Slotted Hole

quarter turn lock - t-handle grip - zinc



One Touch Fasteners

Order No.	l_1	l_2	w_1	w_2 0 -0.05	w_3	Static load N max.
33970.W2103	50	40	30	10	28	500
33970.W2106	50	40	30	10	28	500



Operating Principle

You can slide the steel bar when the knob is at the "OFF" position since there is clearance between the steel bar and the shafts.

The steel bar is locked when the knob is at the "ON" position since the shafts are pushed by the wedge.

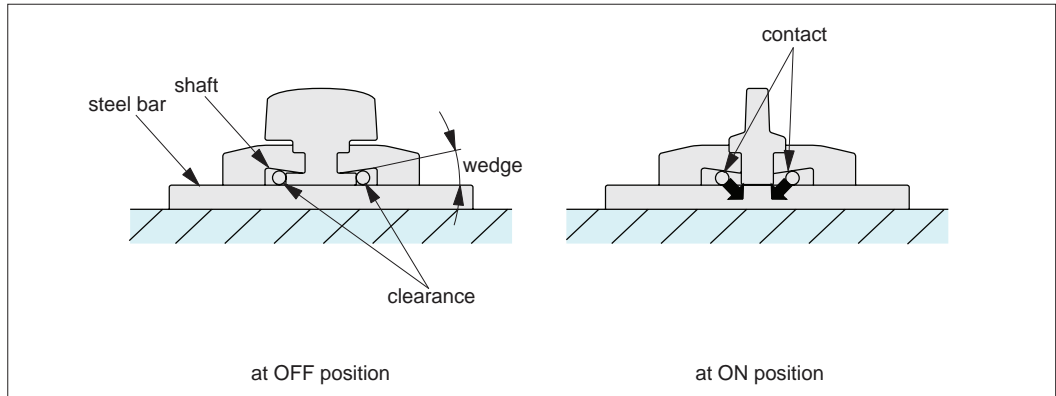

Operating Instructions

- 1 The steel bar can slide to the right and left at the "OFF" position.
- 2 The steel bar is locked at the "ON" position.

Note: The knob clicks at the "ON" and "OFF" positions, and this gives the operator confirmation it has locked/unlocked securely.

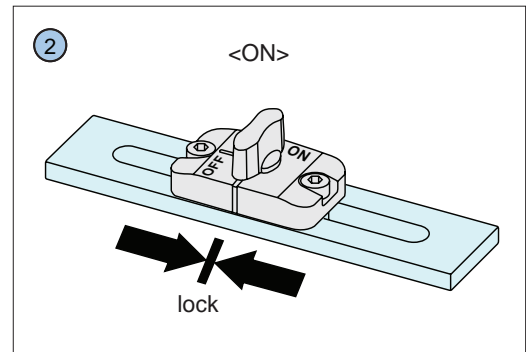
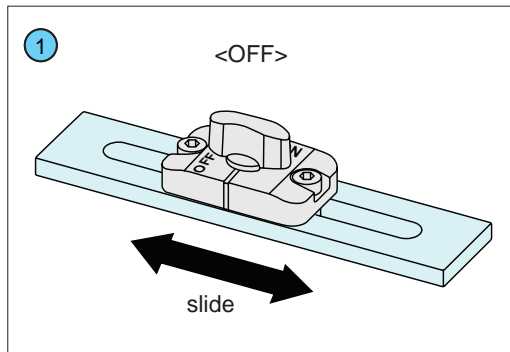

How to Use

Please refer to notes for safe use (last page of guide).

- 1 Slide the steel bar.
- 2 Attach/remove the steel bar.
- 3 Slide the sliding locks for slotted hole.
- 4 Attach/remove the sliding locks for slotted hole.

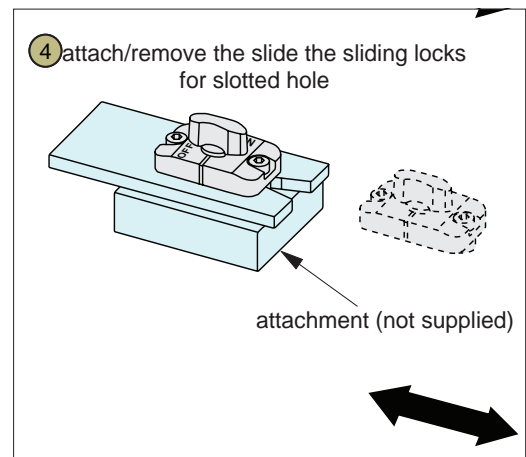
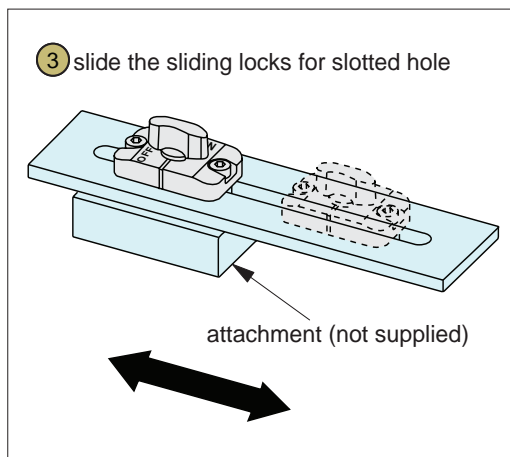
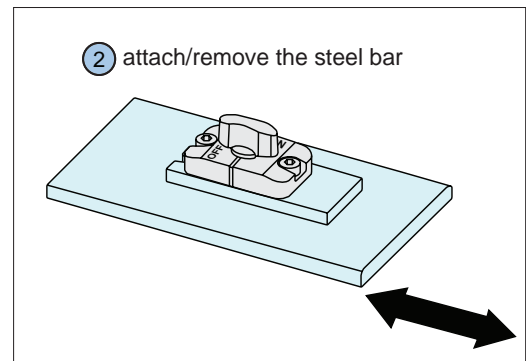
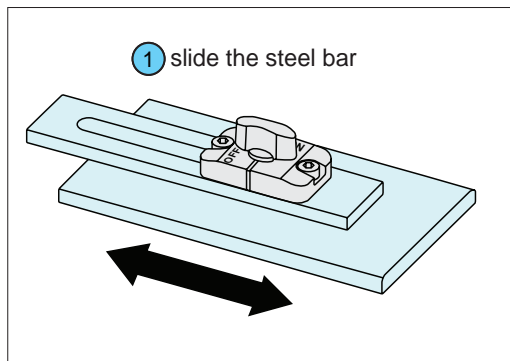



One-Touch Fastener - Sliding clamps

slotted hole - overview



33970

Positioning Elements

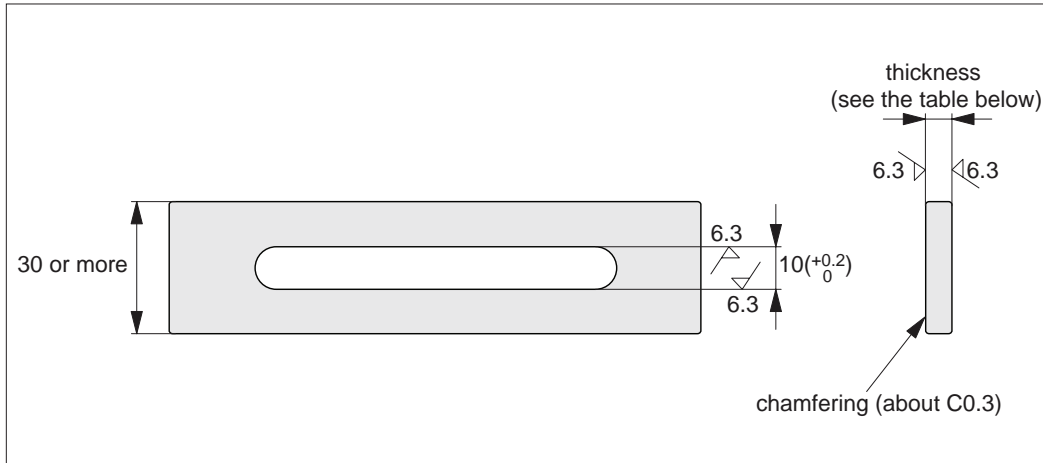

How to Use Steel Bar Materials

Usable Materials: Flat bar (JIS h14 grade) made of SS400, S45C or SUS304 etc.

Machining of slotted hole: Recommended tolerance of the slotted hole to prevent chattering is shown left.

For more accurate sliding, machine the slotted hole to fit the dimension of 10mm (-0.05 to 0) on the bottom of sliding locks. Remove the burr around the slotted hole to ensure locking.

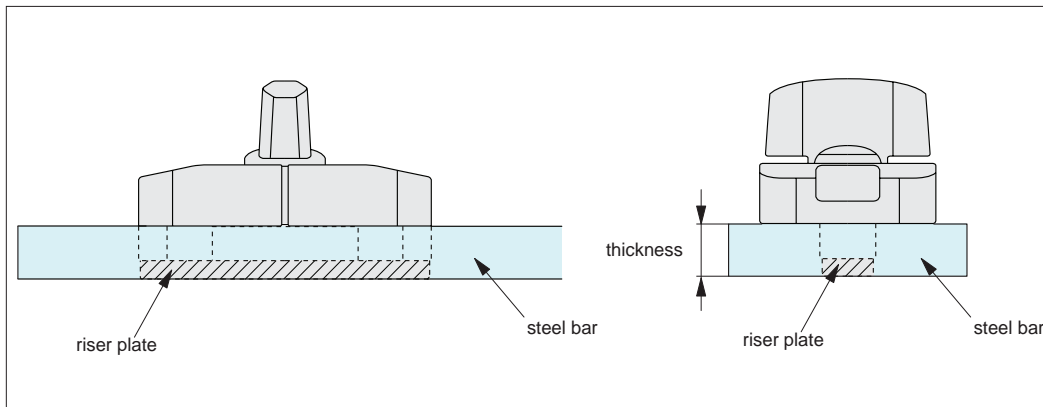

How to Use Riser Plate

Can be used for various steel thicknesses by attaching the riser plates (ordered separately, see 33971).

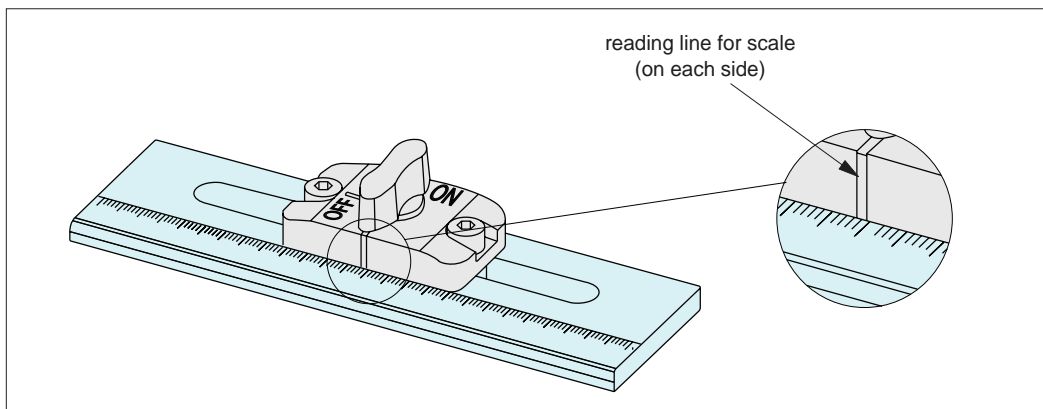

How to Use Scale Plate

You can read the scale with the line on the body of the sliding lock.

Scale plate is separately available.

See ranges 33975, 33976 and 33977.

ONE TOUCH FASTENERS



Notes

- Ensure that the knob is at the "OFF" position when mounting. Mounting of sliding locks the at "ON" position may cause damage.
- The displacement will increase with excess shock or vibration. Do not use this product vertically in environments where excess vibration is present.
- The displacement can increase with adhesion or contamination by oil or foreign substances.
- If the steel plate slips or chatters by the load applied to the steel plate, prepare guides or supports as needed. (See figure 1 and 2 below)
- Excess displacement or misalignment may be caused if there is a clearance between the steel bar and the base when the sliding locks at the "ON" position. (See figure 3 below) Ensure that the steel plate and the base are not bent or warped.

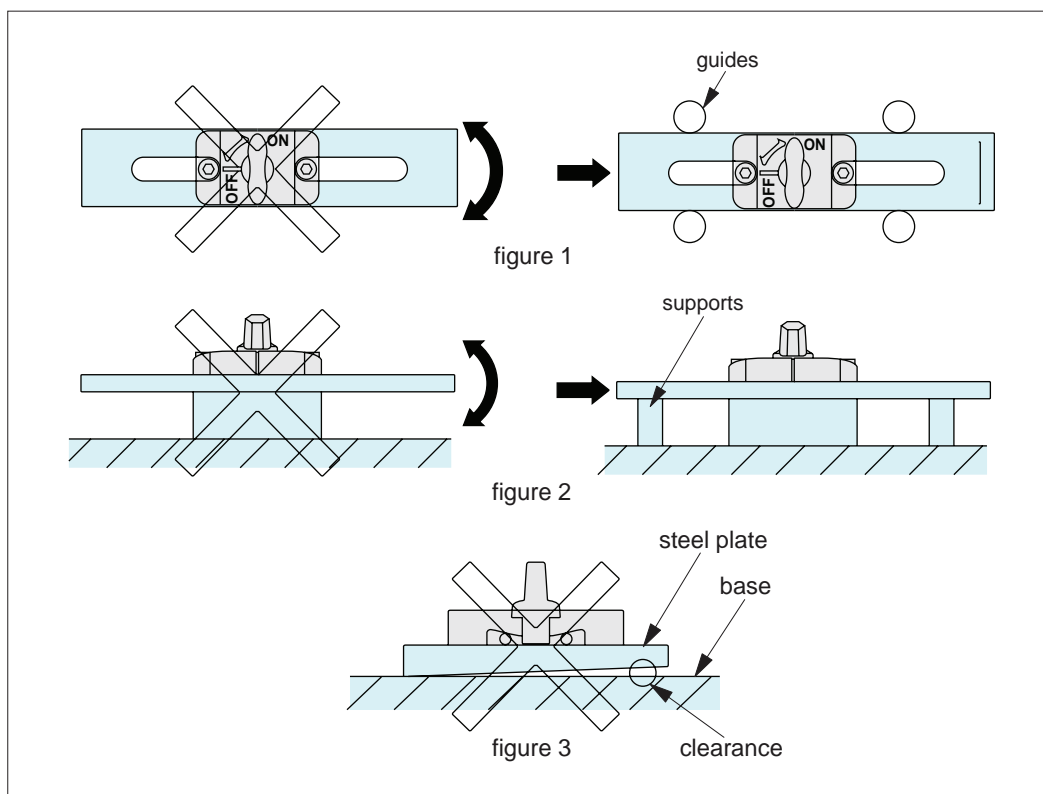

Performance Curve

The Displacement of Steel Bar by Axial Load (static load from single direction)

Note: The data is for a flat bar made of SUS304 stainless steel, SS400 steel and S45C steel. Using an aluminium flat bar the surface will be scratched or dent by applied load.

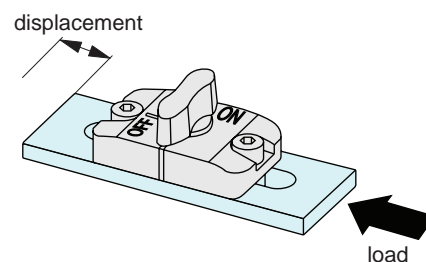
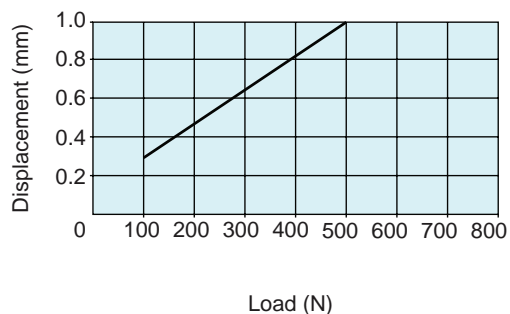

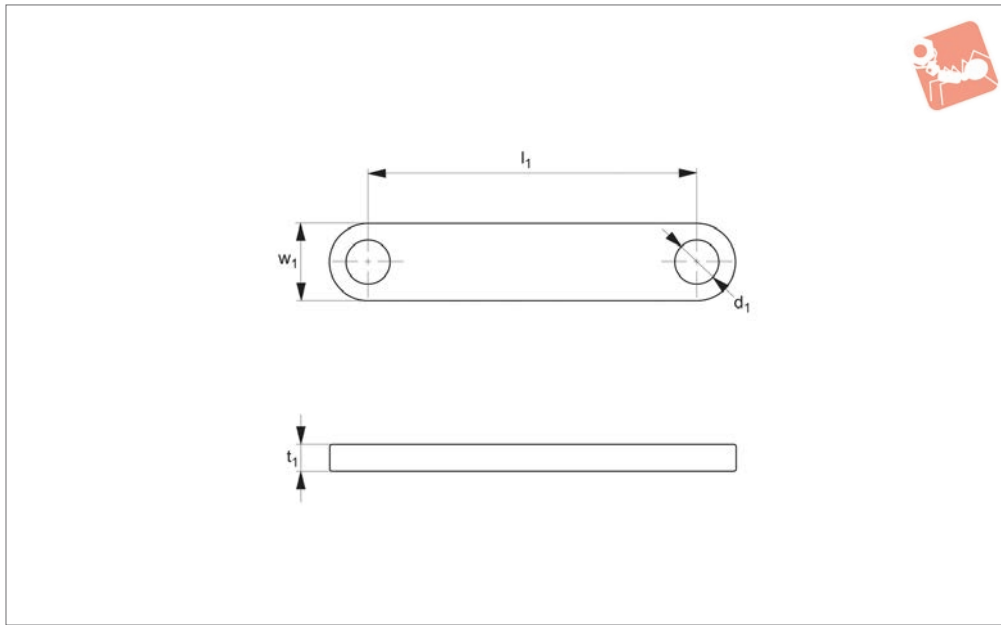

33971

ONE TOUCH FASTENERS

Material

Body: 304 stainless steel.

of riser plate to clamp enables clamps use for sliding bars of varying thickness.

Technical Notes

For use with sliding clamp 33970, addition

Order No.	d ₁	l ₁	w ₁	t ₁	Weight g
33971.W0002	5.5	40	9.5	2	6
33971.W0003	5.5	40	9.5	3	10

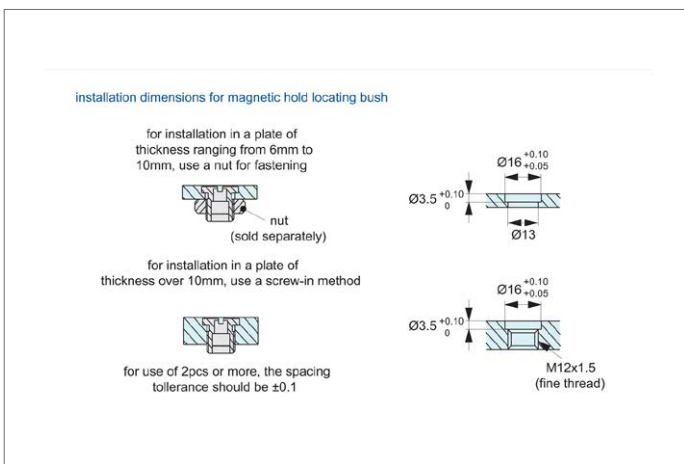



33972

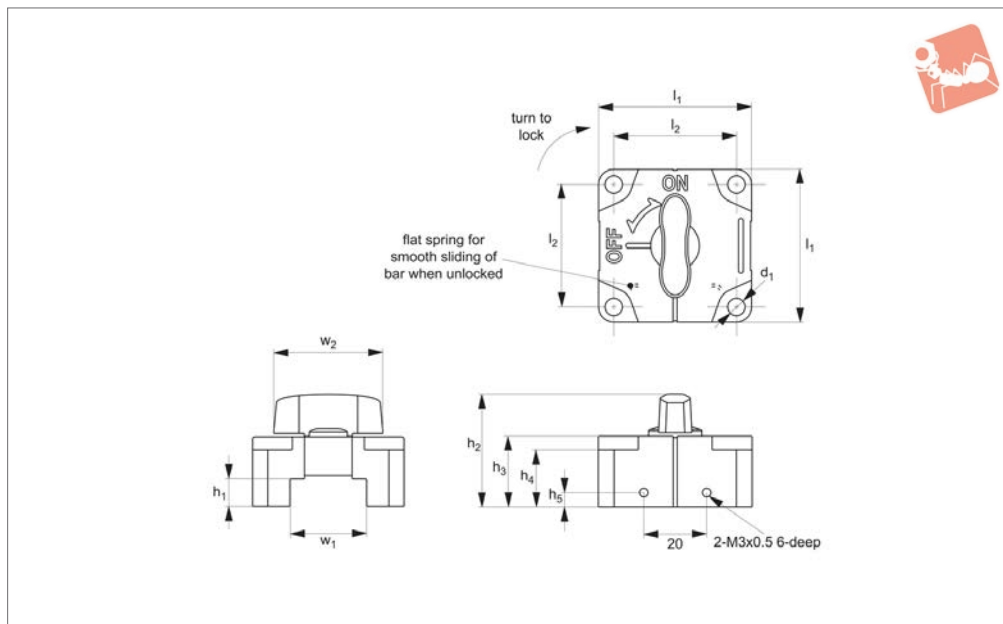

Material

Body: die-cast zinc, chrome plated.
 Grip: polyamide plastic (black or orange), or stainless steel SUS304.
 Clamping shaft/wedge: stainless steel.
 Flat spring: phosphor bronze.

Technical Notes

Sliding clamps are ideal for the quick positioning, locking, releasing and re-positioning of sliding bars in many applications. When additionally used with a scale plate (see part no. 33975, 33976 and 33977), the reading line on the sliding clamp enables quick, easy and accurate alignment.

The sliding clamp is mounted, for greater stability, in a fixed position in an assembly. With the clamp set to its off position the sliding bar (not supplied) can be moved

left or right, with two spring loaded ball plungers provide for free movement of bar. Once in its desired position the sliding bar can be locked in place, through a 90 degree turn of the sliding clamp's handle which engages the clamp's clamping shaft/wedge.

Please see technical diagram below for recommended machining details for your sliding bar (not supplied). Riser plates can be used to provide clearance between sliding bar and mounting surface to improve free running of sliding bar, see part no. 33974.

Temperature resistance up to 90°C.
 Max. static load up to 800N - please refer to performance graph below.

Important Notes

Sliding clamps are suited only to straight linear movement of sliding bar (not supplied), and do not tolerate any other applied loads.

Displacement of sliding bar, through repetitive use, will increase if excessive shock or vibration is present. Do not use sliding clamp in vertical applications where vibration is present.

Displacement will also increase with adhesion or immersion of oil or other foreign substances.

Ensure sliding bar is not bent nor warped as this may cause the sliding bar to slip even when sliding clamp is in its on position.

Order No.	For bar width x height	Handle	d_1	h_1 +0.02	h_2	h_3	h_4	h_5	l_1	l_2	w_1 +0.05 -0.0	w_2	Weight g
33972.W0122	12x12	Plastic, orange	4.5	12	36	22	18.5	6.0	40	32	12	28	130
33972.W0166	16x16	Plastic, orange	4.5	16	40	26	22.5	8.0	40	32	16	28	150
33972.W0250	25x 9	Plastic, orange	5.5	9	37	23	18.5	4.5	50	40	25	35	220
33972.W0252	25x12	Plastic, orange	5.5	12	40	26	21.5	6.0	50	40	25	35	240
33972.W0322	32x12	Plastic, orange	5.5	12	40	26	21.5	6.0	50	40	32	35	220
33972.W0326	32x16	Plastic, orange	5.5	16	44	30	25.5	8.0	50	40	32	35	240
33972.W1122	12x12	Plastic, black	4.5	12	36	22	18.5	6.0	40	32	12	28	130
33972.W1166	16x16	Plastic, black	4.5	16	40	26	22.5	8.0	40	32	16	28	150
33972.W1250	25x 9	Plastic, black	5.5	9	37	23	18.5	4.5	50	40	25	35	220
33972.W1252	25x12	Plastic, black	5.5	12	40	26	21.5	6.0	50	40	25	35	240
33972.W1322	32x12	Plastic, black	5.5	12	40	26	21.5	6.0	50	40	32	35	220
33972.W1326	32x16	Plastic, black	5.5	16	44	30	25.5	8.0	50	40	32	35	240
33972.W2122	12x12	Stainless	4.5	12	36	22	18.5	6.0	40	32	12	28	145
33972.W2166	16x16	Stainless	4.5	16	40	26	22.5	8.0	40	32	16	28	165
33972.W2250	25x 9	Stainless	5.5	9	37	23	18.5	4.5	50	40	25	35	245



Sliding Clamps - for Solid Sliding Bar

quarter turn lock - t-handle grip - zinc



One Touch Fasteners

Order No.	For bar width x height	Handle	d ₁	h ₁ +0.02	h ₂	h ₃	h ₄	h ₅	l ₁	l ₂	w ₁ +0.05 -0.0	w ₂	Weight g
33972.W2252	25x12	Stainless	5.5	12	40	26	21.5	6.0	50	40	25	35	265
33972.W2322	32x12	Stainless	5.5	12	40	26	21.5	6.0	50	40	32	35	245
33972.W2326	32x16	Stainless	5.5	16	44	30	25.5	8.0	50	40	32	35	265



33973

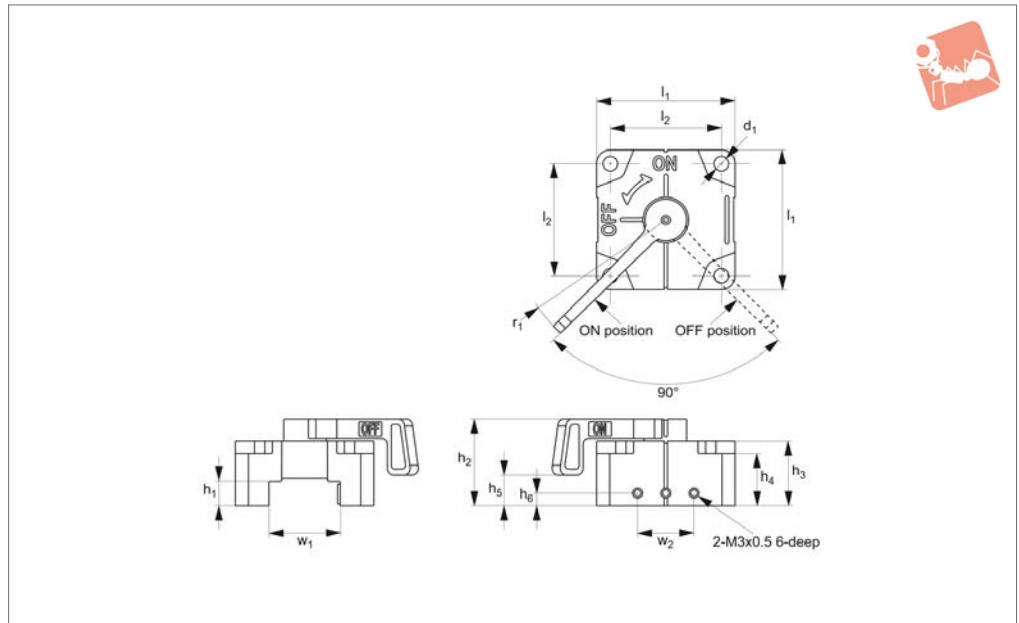

Material

Body: die-cast zinc, chrome plated.
 Handle: stainless steel SUS304.
 Clamping shaft/wedge: stainless steel.
 Flat spring: phosphor bronze.

Technical Notes

Sliding clamps are ideal for the quick positioning, locking, releasing and re-positioning of sliding bars in many applications. When additionally used with a scale plate (see part no. 33975, 33976 and 33977), the reading line on the sliding clamp enables quick, easy and accurate alignment.

The sliding clamp is mounted, for greater stability, in a fixed position in an assembly. With the clamp set to its off position the sliding bar (not supplied) can be moved

left or right, with two spring loaded ball plungers provide for free movement of bar. Once in its desired position the sliding bar can be locked in place, through a 90 degree turn of the sliding clamp's handle which engages the clamp's clamping shaft/wedge.

Please see technical diagram below for recommended machining details for your sliding bar (not supplied). Riser plates can be used to provide clearance between sliding bar and mounting surface to improve free running of sliding bar, see part no. 33974.

Temperature resistance upto 90°C.
 Max. static load upto 800N - please refer to performance graph below.

Important Notes

Sliding clamps are suited only to straight linear movement of sliding bar (not supplied), and do not tolerate any other applied loads.

Displacement of sliding bar, through repetitive use, will increase if excessive shock or vibration is present. Do not use sliding clamp in vertical applications where vibration is present.

Displacement will also increase with adhesion or immersion of oil or other foreign substances.

Ensure sliding bar is not bent nor warped as this may cause the sliding bar to slip even when sliding clamp is in its on position.

Order No.	For bar width x height	Handle	d ₁	h ₁ +0.02	h ₂	h ₃	h ₄	h ₅	h ₆	l ₁	l ₂	w ₁ +0.05 -0.0	w ₂	r ₁	Static load N max.	Weight g
33973.W2122	12x12	Stainless	4,5	12	29	22	18,5	11	6,0	40	32	12	20	46,0	500	150
33973.W2166	16x16	Stainless	4,5	16	33	26	22,5	15	8,0	40	32	16	20	46,0	500	160
33973.W2250	25x 9	Stainless	5,5	9	31	23	18,5	11	4,5	50	40	25	20	55,5	800	250
33973.W2252	25x12	Stainless	5,5	12	34	26	21,5	14	6,0	50	40	25	20	55,5	800	250
33973.W2322	32x12	Stainless	5,5	12	34	26	21,5	14	6,0	50	40	32	20	55,5	800	320
33973.W2326	32x16	Stainless	5,5	16	38	30	25,5	18	8,0	50	40	32	20	55,5	800	270



Sliding Clamps - for Solid Sliding Bar

quarter turn lock - lever handle grip - zinc



One Touch Fasteners

installation dimensions for magnetic hold locating bush

for installation in a plate of thickness ranging from 6mm to 10mm, use a nut for fastening



nut
(sold separately)

for installation in a plate of thickness over 10mm, use a screw-in method



for use of 2pcs or more, the spacing tolerance should be ± 0.1

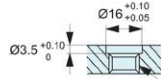
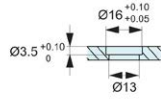

M12x1.5
(fine thread)



Operating Principle

You can slide the steel bar when the knob is at the "OFF" position since there is clearance between the steel bar and the shafts.

The steel bar is locked when the knob is at the "ON" position since the shafts are pushed by the wedge.

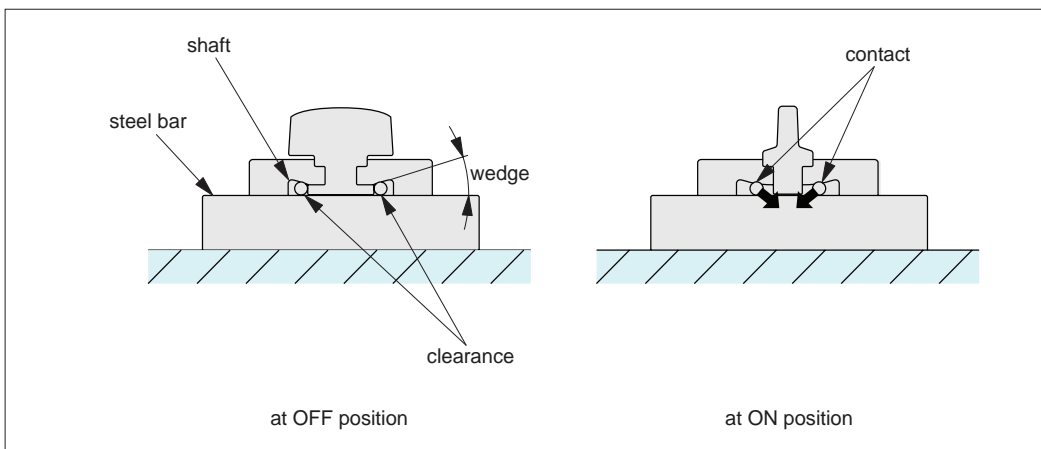

Operating Instructions

The steel bar can slide to right and left at the "OFF" position.

The steel bar is locked at the "ON" position.

Note: The knob clicks at the "ON" and "OFF" positions, and this enables the operators to lock/unlock securely.

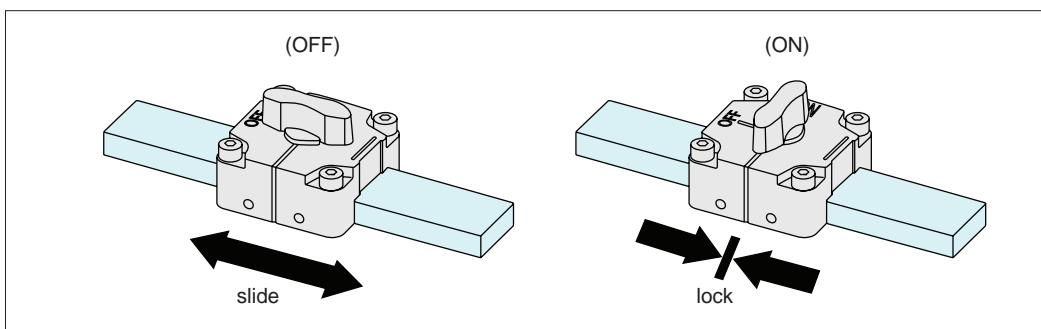

How to use

Please refer to notes for safe use (see last page of guide).

- ① Slide the steel bar.
- ② Slide the sliding locks for square bar.

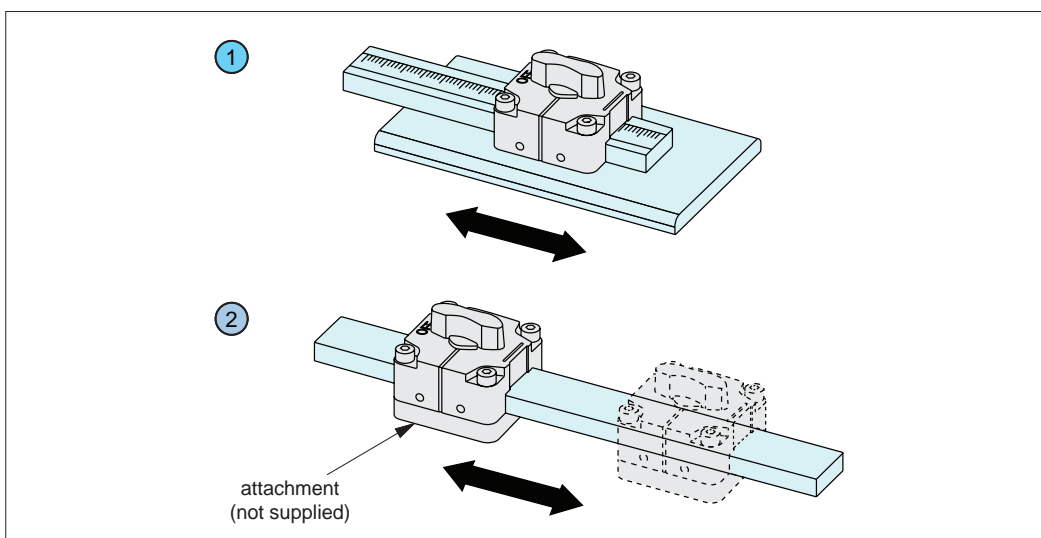

How to use steel bar materials

Usable Materials: Flat bar (JIS h14 grade) made of SS400, S45C or SUS304 etc.

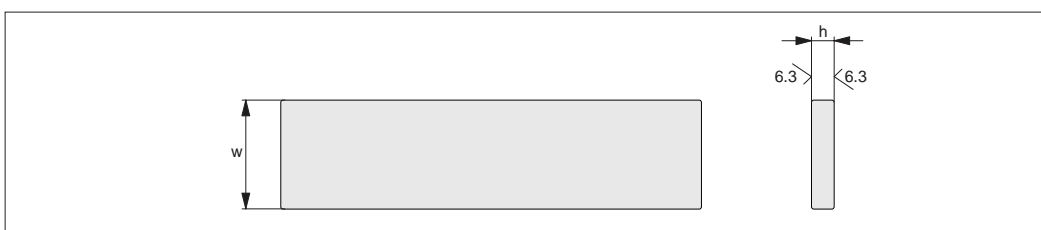



How to Use Riser Plate

Riser plates (to be ordered separately) can lift the steel bar to create a clearance between the steel bar and the base.

How to Use Tapped Holes on Side Surface

Can be used with attachments such as pointer plates and brackets.

How to Use Scale Plate

Scale plate can be put on the steel bar.

Note: Fit scale plate inside the slot in the figure below. Putting scale plate outside the slot cause interference between scale plate and sliding lock.

Scale plate is separately available.

See ranges 33975, 33976 and 33977.

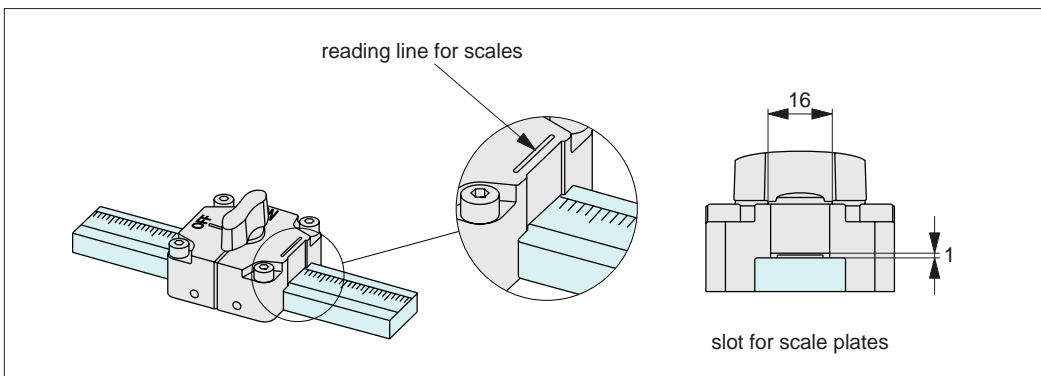
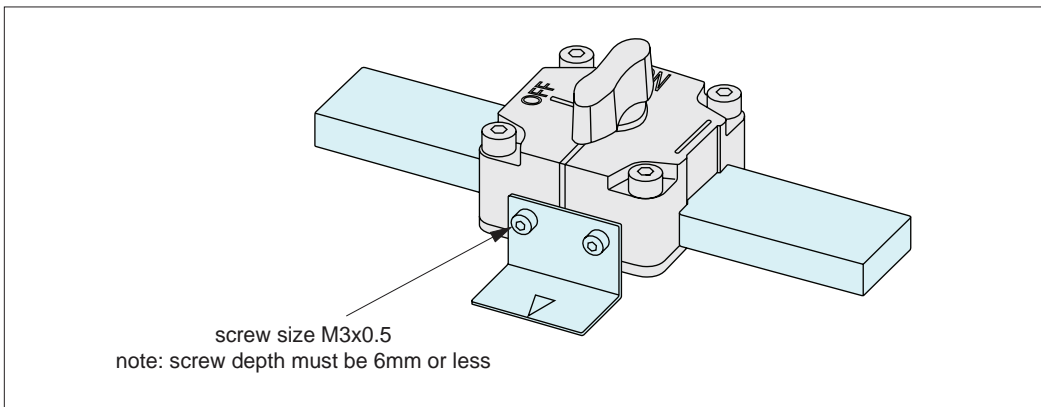
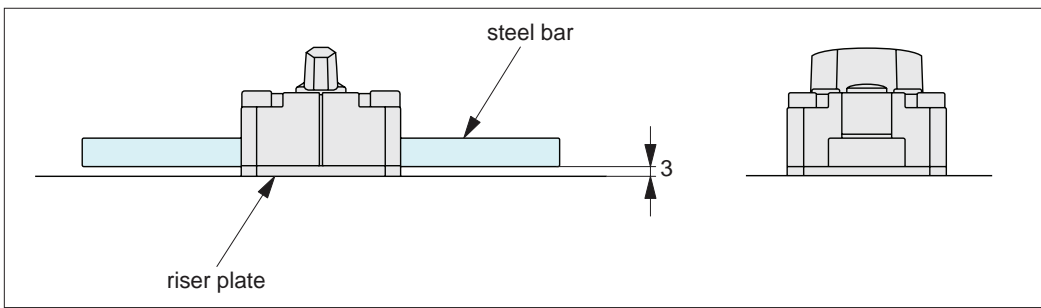



Performance Curve

Displacement of Steel Bar by Axial Load (static load from single direction)

A: For bar width x heights; 12x12mm and 16x16mm.

B: For bar width x heights; 25x9, 25x12, 32x12, 32x16.

Note: This data is for a flat bar made of SUS304 stainless steel, SS400 steel and S45C steel. Using an aluminium flat bar, the surface will be scratched or dented by applied load.

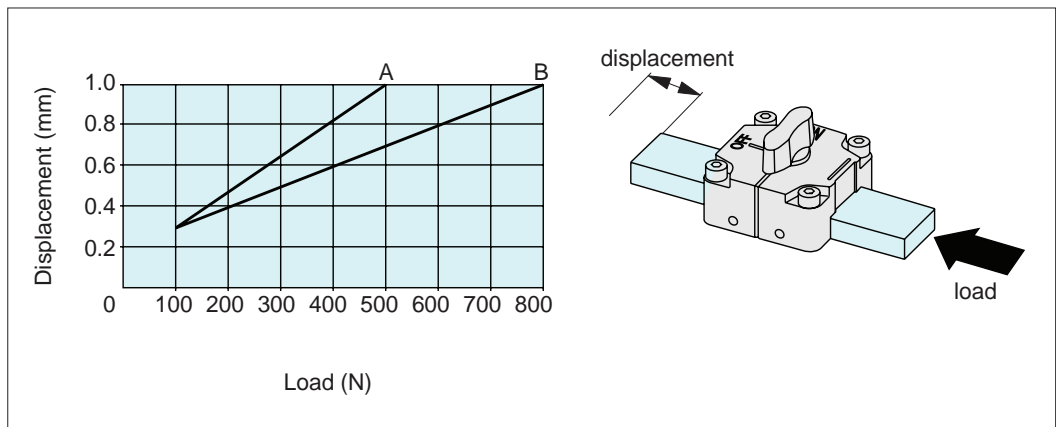

Notes

- Ensure that the knob is at the "OFF" position when mounting. Mounting of sliding locks at the "ON" position may cause damage.
- The displacement will increase with excess shock or vibration. Do not use this product vertically in environments where excess vibration is present.
- The displacement can increase with adhesion or contamination by oil or foreign substances.
- If the steel plate slips or chatters by the load applied to the steel plate, prepare guides or supports as needed. (See figure 1 and 2 below)
- Excess displacement or misalignment may be caused if there is a clearance between the steel bar and the base when the sliding locks at "ON" position. (See figure 3 below) Ensure that the steel plate and the base are not bent or warped.

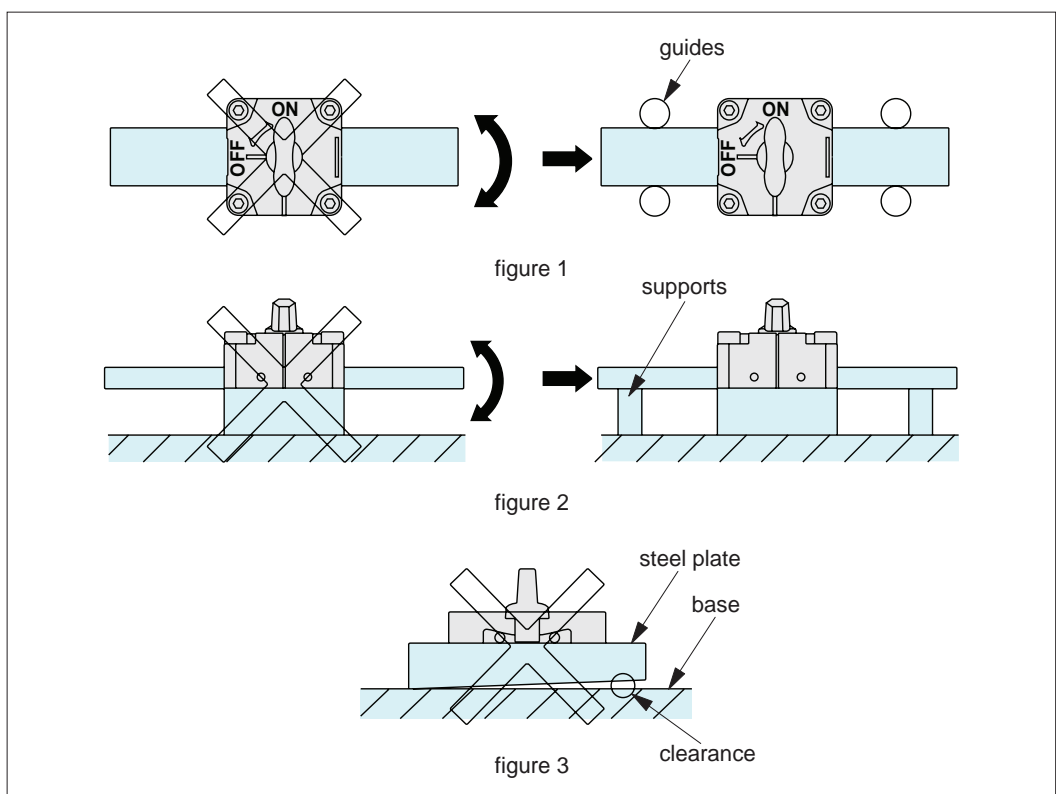



Riser Plates for Sliding Clamps

for 33972 and 33973



One Touch Fasteners

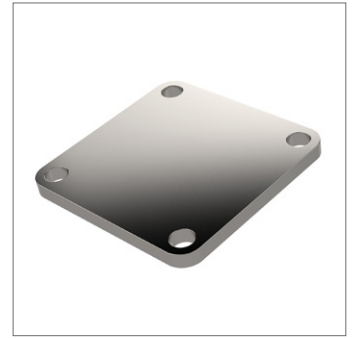
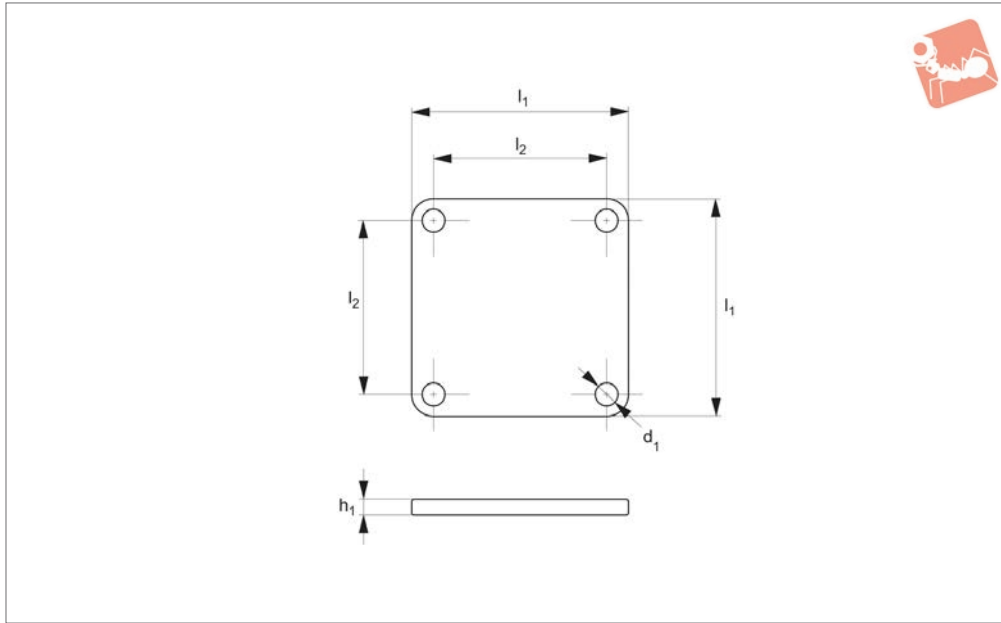

33974

ONE TOUCH FASTENERS

Material

Body: stainless steel, SUS 304

Technical Notes

To be used with sliding clamps part no. 33972 and 33973

Order No.	d_1	h_1	l_1	l_2	Weight g
33974.W4032	4.5	3	40	32	35
33974.W5040	5.5	3	50	40	55

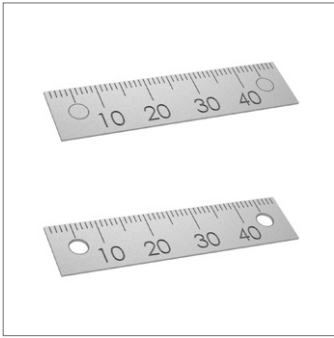

33975

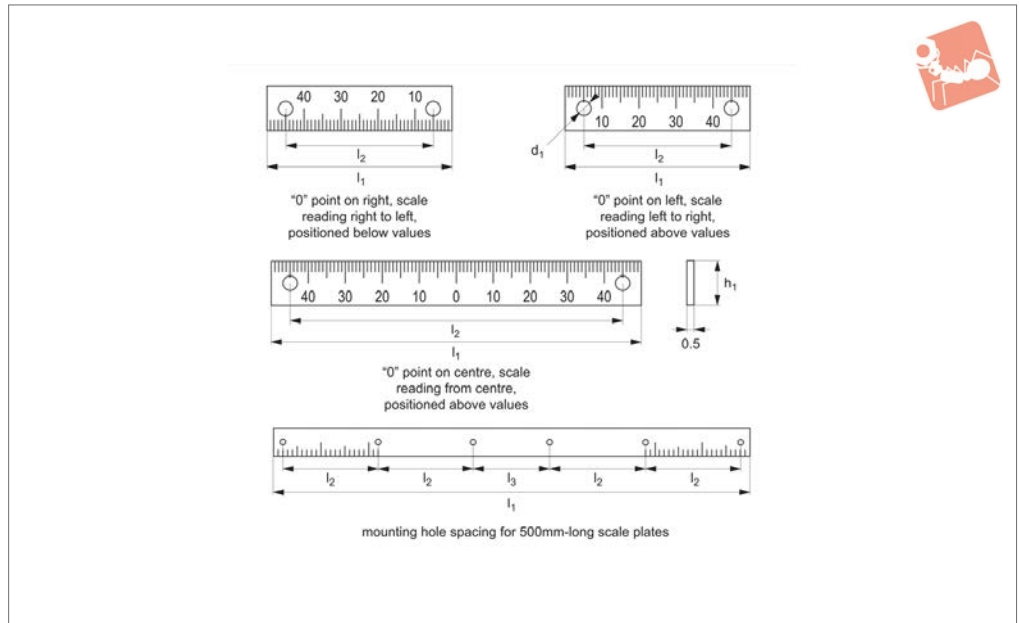

Material

Aluminium, with etched graduation/ markings.

Technical Notes

For use with sliding clamps 33970, 33972 and 33973. Markings are for indicative purposes, and are not intended for precise

measurement.

Adhesive mounting type: ensure receiving surface is clean and dirt free (features outline of screw hole location, not drilled).

Screw mounting type: holes drilled to

3,5mm dia.

When selecting scale plate consider;

- direction scale reads (left to right, right to left or from centre).
- position of scale relative to number valves (above, below or both).

Order No.	Mounting type	Number of mounting holes	Direction of measurement	Scale position	d_1 (marked) drilled	h_1	l_1	l_2	l_3	Weight g
33975.W1005	Adhesive	2	Left	Top	(3,5)	12	50	40		0,8
33975.W1010	Adhesive	2	Left	Top	(3,5)	12	100	90		1,6
33975.W1015	Adhesive	3	Left	Top	(3,5)	12	150	70		2,4
33975.W1020	Adhesive	3	Left	Top	(3,5)	12	200	95		3,2
33975.W1030	Adhesive	2	Right	Top	(3,5)	12	50	40		0,8
33975.W1035	Adhesive	2	Right	Top	(3,5)	12	100	90		1,6
33975.W1040	Adhesive	3	Right	Top	(3,5)	12	150	70		2,4
33975.W1045	Adhesive	3	Right	Top	(3,5)	12	200	95		3,2
33975.W1055	Adhesive	2	Centre	Top	(3,5)	12	100	90		1,6
33975.W1060	Adhesive	3	Centre	Top	(3,5)	12	200	95		3,2
33975.W2005	Adhesive	2	Left	Bottom	(3,5)	12	50	40		0,8
33975.W2010	Adhesive	2	Left	Bottom	(3,5)	12	100	90		1,6
33975.W2015	Adhesive	3	Left	Bottom	(3,5)	12	150	70		2,4
33975.W2020	Adhesive	3	Left	Bottom	(3,5)	12	200	95		3,2
33975.W2030	Adhesive	2	Right	Bottom	(3,5)	12	50	40		0,8
33975.W2035	Adhesive	2	Right	Bottom	(3,5)	12	100	90		1,6
33975.W2040	Adhesive	3	Right	Bottom	(3,5)	12	150	70		2,4
33975.W2045	Adhesive	3	Right	Bottom	(3,5)	12	200	95		3,2
33975.W2055	Adhesive	2	Centre	Bottom	(3,5)	12	100	90		1,6
33975.W2060	Adhesive	3	Centre	Bottom	(3,5)	12	200	95		3,2
33975.W5005	Screw Mount	2	Left	Top	3,5	12	50	40		0,8
33975.W5010	Screw Mount	2	Left	Top	3,5	12	100	90		1,6
33975.W5015	Screw Mount	3	Left	Top	3,5	12	150	70		2,4
33975.W5020	Screw Mount	3	Left	Top	3,5	12	200	95		3,2
33975.W5025	Screw Mount	6	Left	Top	3,5	12	500	100	90	8,0
33975.W5030	Screw Mount	2	Right	Top	3,5	12	50	40		0,8
33975.W5035	Screw Mount	2	Right	Top	3,5	12	100	90		1,6
33975.W5040	Screw Mount	3	Right	Top	3,5	12	150	70		2,4
33975.W5045	Screw Mount	3	Right	Top	3,5	12	200	95		3,2
33975.W5050	Screw Mount	6	Right	Top	3,5	12	500	100	90	8,0



Scale Plates - Single Scale

for sliding clamps 33970, 33972, 33973



One Touch Fasteners

Order No.	Mounting type	Number of mounting holes	Direction of measurement	Scale position	d_1 (marked) drilled	h_1	l_1	l_2	l_3	Weight g
33975.W5055	Screw Mount	2	Centre	Top	3,5	12	100	90		1,6
33975.W5060	Screw Mount	3	Centre	Top	3,5	12	200	95		3,2
33975.W5065	Screw Mount	6	Centre	Top	3,5	12	500	100	90	8,0
33975.W6005	Screw Mount	2	Left	Bottom	3,5	12	50	40		0,8
33975.W6010	Screw Mount	2	Left	Bottom	3,5	12	100	90		1,6
33975.W6015	Screw Mount	3	Left	Bottom	3,5	12	150	70		2,4
33975.W6020	Screw Mount	3	Left	Bottom	3,5	12	200	95		3,2
33975.W6025	Screw Mount	6	Left	Bottom	3,5	12	500	100	90	8,0
33975.W6030	Screw Mount	2	Right	Bottom	3,5	12	50	40		0,8
33975.W6035	Screw Mount	2	Right	Bottom	3,5	12	100	90		1,6
33975.W6040	Screw Mount	3	Right	Bottom	3,5	12	150	70		2,4
33975.W6045	Screw Mount	3	Right	Bottom	3,5	12	200	95		3,2
33975.W6050	Screw Mount	6	Right	Bottom	3,5	12	500	100	90	8,0
33975.W6055	Screw Mount	2	Centre	Bottom	3,5	12	100	90		1,6
33975.W6060	Screw Mount	3	Centre	Bottom	3,5	12	200	95		3,2
33975.W6065	Screw Mount	6	Centre	Bottom	3,5	12	500	100	90	8,0

ONE TOUCH FASTENERS

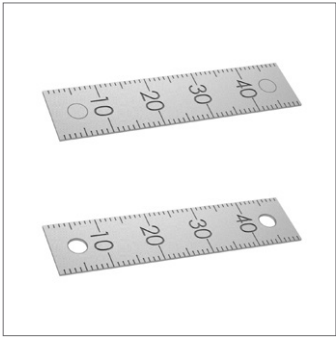

33976

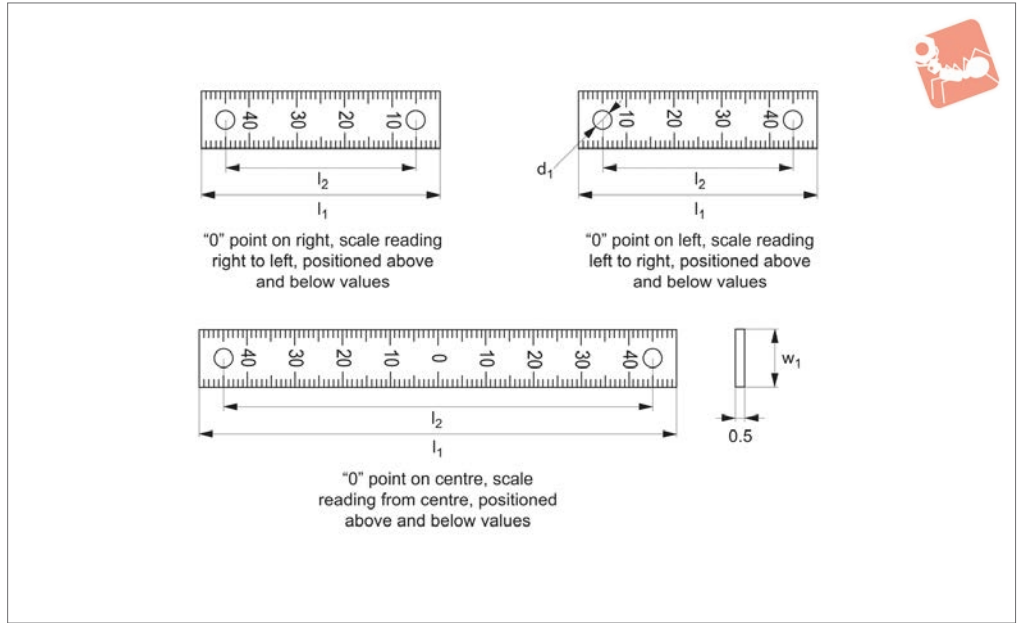

Material

Aluminium, with etched graduation/ markings.

Technical Notes

For use with sliding clamps 33970, 33972 and 33973. Markings are for indicative purposes, and are not intended for precise

measurement.

Adhesive mounting type: ensure receiving surface is clean and dirt free (features outline of screw hole location, not drilled).

Screw mounting type: holes drilled to

3,5mm dia.

When selecting scale plate consider;
 - direction scale reads (left to right, right to left or from centre).
 - position of scale relative to number valves (above, below or both).

Order No.	Mounting type	Number of mounting holes	Location of „0“ point	d ₁	l ₁	l ₂	w ₁	Weight g
33976.W1005	Adhesive	2	Left	-	50	40	15	1
33976.W1010	Adhesive	2	Left	-	100	90	15	2
33976.W1015	Adhesive	2	Right	-	50	40	15	1
33976.W1020	Adhesive	2	Right	-	100	90	15	2
33976.W1025	Adhesive	2	Centre	-	100	90	15	2
33976.W5005	Screw Mount	2	Left	3.5	50	40	15	1
33976.W5010	Screw Mount	2	Left	3.5	100	90	15	2
33976.W5015	Screw Mount	2	Right	3.5	50	40	15	1
33976.W5020	Screw Mount	2	Right	3.5	100	90	15	2
33976.W5025	Screw Mount	2	Centre	3.5	100	90	15	2

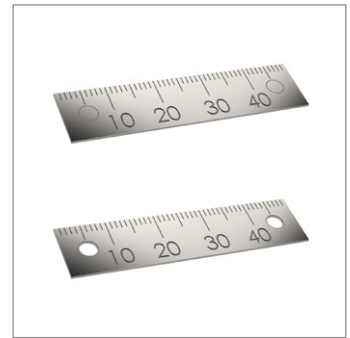
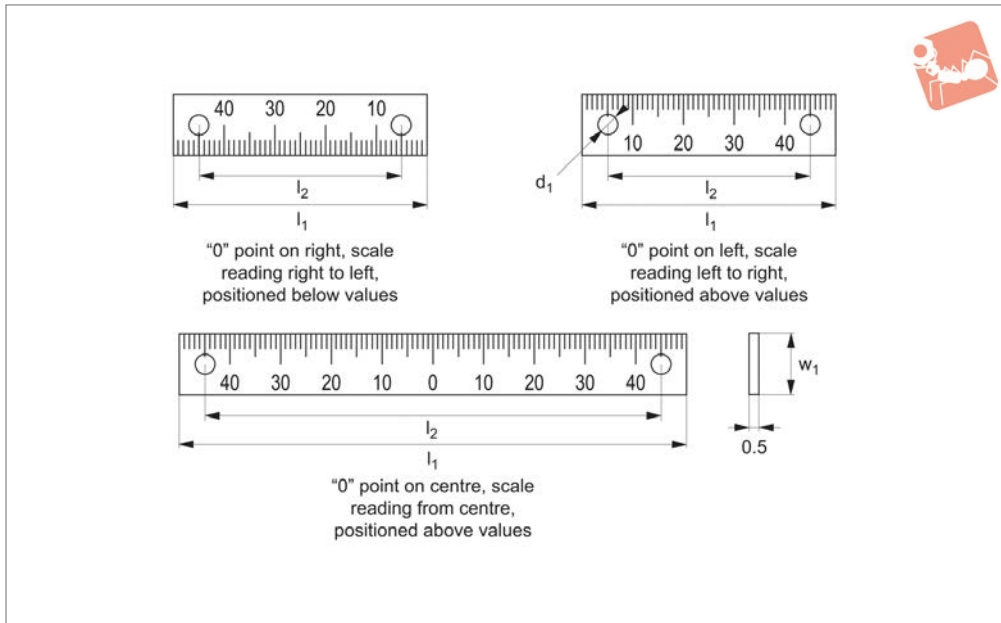

33977

ONE TOUCH FASTENERS

Material

Stainless steel, with etched graduation/ markings.

Technical Notes

For use with sliding clamps 33970, 33972 and 33973. Markings are for indicative purposes, and are not intended for precise

measurement.

Adhesive mounting type: ensure receiving surface is clean and dirt free (features outline of screw hole location, not drilled).

Screw mounting type: holes drilled to

3,5mm dia.

When selecting scale plate consider;
 - direction scale reads (left to right, right to left or from centre).
 - position of scale relative to number valves (above, below or both).

Order No.	Mounting type	Number of mounting holes	Location of „0“ point	d ₁	l ₁	l ₂	w ₁	Weight g
33977.W1005	Adhesive	2	Top	-	50	40	12	2.4
33977.W1010	Adhesive	2	Top	-	100	90	12	4.7
33977.W1015	Adhesive	2	Top	-	50	40	12	2.4
33977.W1020	Adhesive	2	Top	-	100	90	12	4.7
33977.W1025	Adhesive	2	Top	-	100	90	12	4.7
33977.W5005	Screw-Mount	2	Top	3.5	50	40	12	2.4
33977.W5010	Screw-Mount	2	Top	3.5	100	90	12	4.7
33977.W5015	Screw-Mount	2	Top	3.5	50	40	12	2.4
33977.W5020	Screw-Mount	2	Top	3.5	100	90	12	4.7
33977.W5025	Screw-Mount	2	Top	3.5	100	90	12	4.7



33980

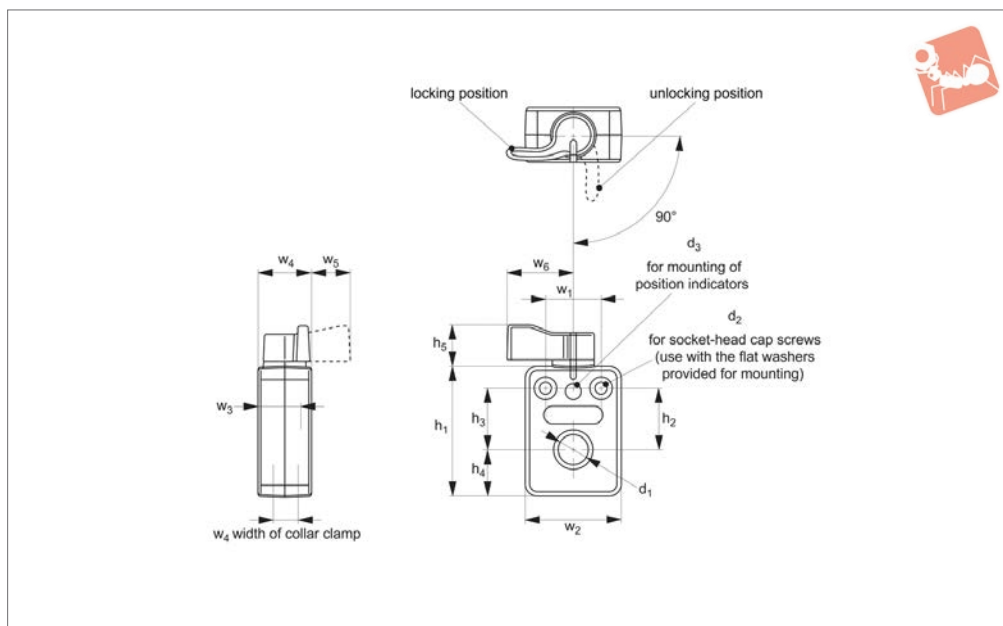

Material

Housing: Polyamide (glass-fibre reinforced)

Boss: Polyamide (glass-fibre reinforced)

Base: Polyamide (glass-fibre reinforced)

Insert: Stainless steel

Technical Notes

It has teeth inside and it engages at every 7.2° (=360°/ 50).

33981 pulls the spindle by the inner spring with 70N force to prevent chattering of the spindle. Note: The spindle should be fully inserted into the knob for 25mm.

Order No.	Handle	d ₁ for shaft dia. tol. h7	d ₂	d ₃	h ₁	h ₂	h ₃	h ₄	Weight g
33980.W1308	Orange	8	M 4	6	48.5	23.5	22	17	50
33980.W1310	Orange	10	M 4	6	48.5	23.5	22	17	50
33980.W1312	Orange	12	M 4	6	48.5	23.5	22	17	50
33980.W1314	Orange	14	M 4	6	48.5	23.5	22	17	50
33980.W1512	Orange	12	M 5	6	69.0	17.0	30	26	100
33980.W1515	Orange	15	M 5	6	69.0	17.0	30	26	100
33980.W1516	Orange	16	M 5	6	69.0	17.0	30	26	100
33980.W1520	Orange	20	M 5	6	69.0	17.0	30	26	100
33980.W2308	Black	8	M 4	6	48.5	23.5	22	17	50
33980.W2310	Black	10	M 4	6	48.5	23.5	22	17	50
33980.W2312	Black	12	M 4	6	48.5	23.5	22	17	21
33980.W2314	Black	14	M 4	6	48.5	23.5	22	17	21
33980.W2512	Black	12	M 5	6	69.0	17.0	30	26	100
33980.W2515	Black	15	M 5	6	69.0	17.0	30	26	100
33980.W2516	Black	16	M 5	6	69.0	17.0	30	26	100
33980.W2520	Black	20	M 5	6	69.0	17.0	30	26	34

Order No.	h ₅	w ₁	w ₂	w ₃	w ₄	w ₅	w ₆	Allowable holding torque	
								Nm max.	Allowable sliding torque Nm max.
33980.W1308	15.5	21	36	14.0	20	15	25	3	400
33980.W1310	15.5	21	36	14.0	20	15	25	3	400
33980.W1312	15.5	21	36	14.0	20	15	25	4	400
33980.W1314	15.5	21	36	14.0	20	15	25	4	400
33980.W1512	15.5	34	51	12.5	20	15	25	5	500
33980.W1515	15.5	34	51	12.5	20	15	25	5	500
33980.W1516	15.5	34	51	12.5	20	15	25	6	500
33980.W1520	15.5	34	51	12.5	20	15	25	6	500
33980.W2308	15.5	21	36	14.0	20	15	25	3	400
33980.W2310	15.5	21	36	14.0	20	15	25	3	400
33980.W2312	15.5	21	36	14.0	20	15	25	4	400
33980.W2314	15.5	21	36	14.0	20	15	25	4	400
33980.W2512	15.5	34	51	12.5	20	15	25	5	500



Sliding Clamps - for Solid Round Bar

quarter turn lock- l-handle grip - polyamide



One Touch Fasteners

Order No.	h_5	w_1	w_2	w_3	w_4	w_5	w_6	Allowable holding torque Nm max.	Allowable sliding torque Nm max.
33980.W2515	15.5	34	51	12.5	20	15	25	5	500
33980.W2516	15.5	34	51	12.5	20	15	25	6	500
33980.W2520	15.5	34	51	12.5	20	15	25	6	500



Operating Principle

- One-touch spindle locks enable quick and secure locking of shafts with one click of the knob.
- When one-touch spindle lock is operated, the knob clicks and the shaft is locked with a steady force. This provides reliable locking of shafts.
- The knob position and the indication line clearly indicate lock/unlock position.

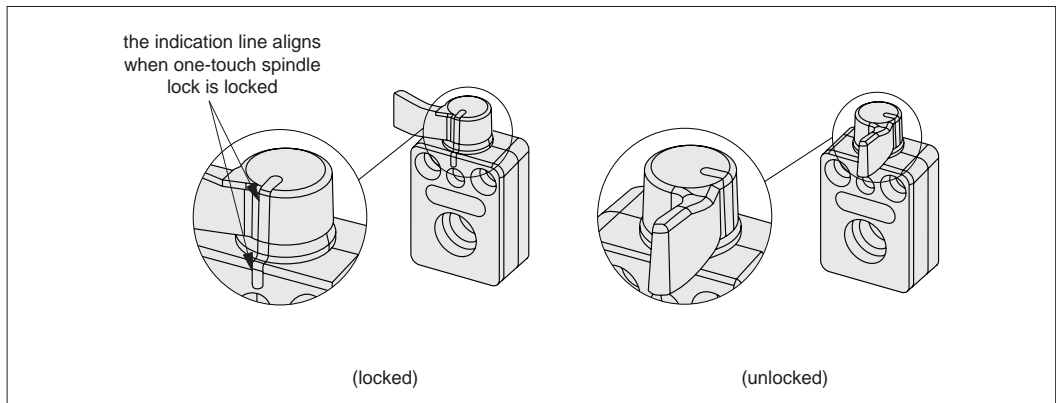

Operating Instructions

Note: To mount position indicators to one-touch spindle locks, use the rubber cushion supplied with position indicators.

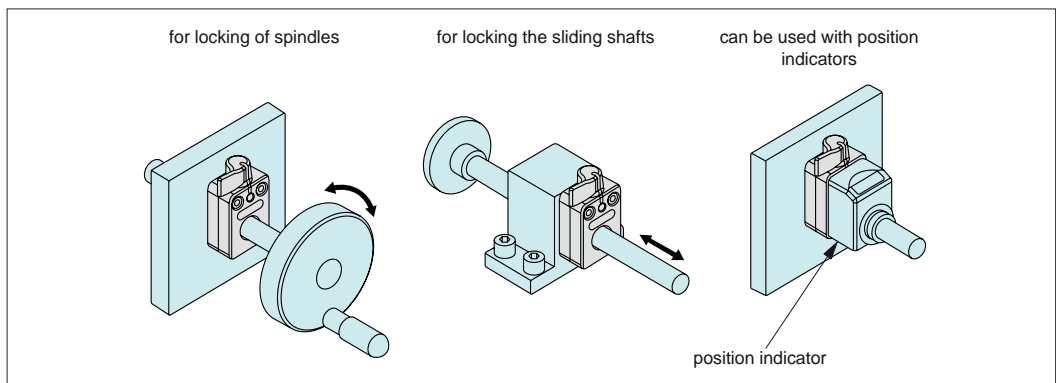

Load Ratings

One-touch spindle locks can fix both revolving and sliding shafts.

For shaft $\varnothing h_7$	d_2	Max. holding torque Nm	Max. axial load N
8	M4	3	400
10	M4	3	400
12	M4	4	400
14	M4	4	400
12	M5	5	500
15	M5	5	500
16	M5	6	500
20	M5	6	500

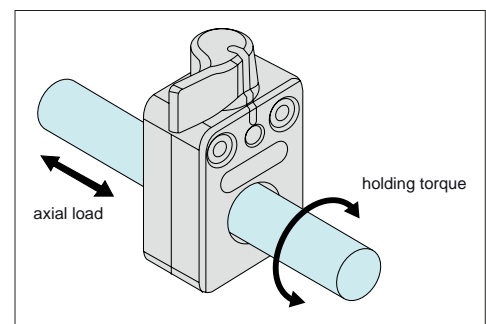

Notes

- This product cannot be used as bearings or guides for shafts.
- Shafts may slip in environments where shocks or vibrations are present.
- The allowable holding torque and the allowable sliding load may decrease with adhesion of particles or immersion in oil.

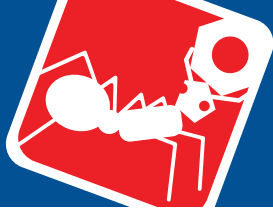

One-Touch Locking Knobs with safety indicator



One Touch Fasteners

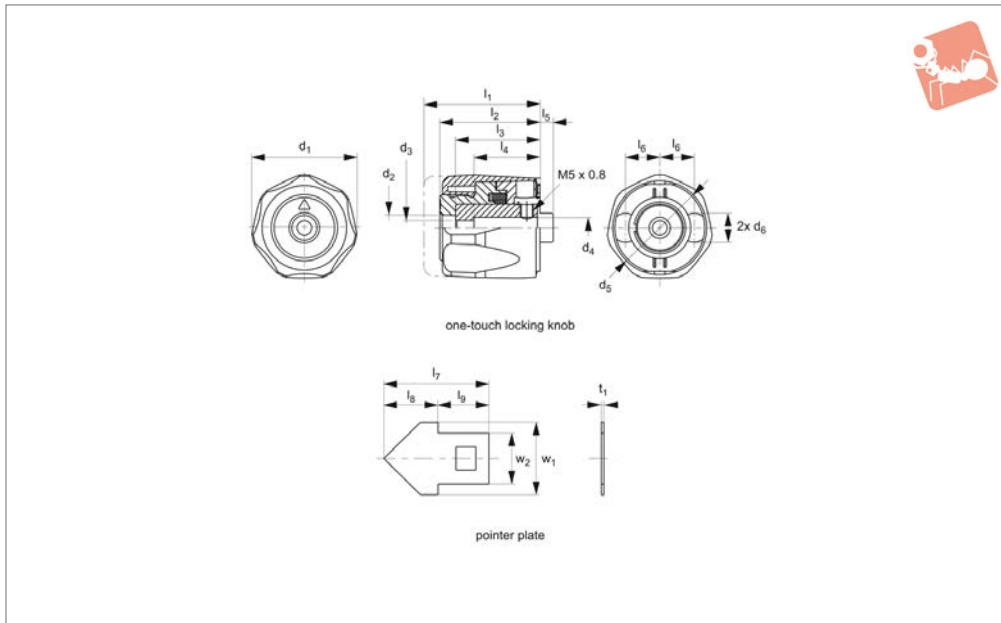

33981

ONE TOUCH FASTENERS

Material

Grip: reinforced polyamide, black or orange.
 Central boss: reinforced polyamide, blue.
 Base indicator: reinforced polyamide, red.
 Pointer plate: stainless steel A2.
 Supplied with screws.

Technical Notes

One-touch locking knob enables one-touch locking and unlocking of spindle. One-Touch locking knob has an audible click to indicate locking and unlocking. Additionally the high visibility red colour of the base indicator is exposed to signify

when knob is unlocked (when locked the red indicator is concealed).

Important Notes

* Safety factor of 5.
 Pointer plate sold separately.

Order No.	d ₁	d ₂	d ₃	d ₄	d ₅	d ₆ -0.2	l ₁	l ₂	l ₃	l ₄	l ₅	Weight g
33981.W4008	40	9.5	5.5	8	34	11	44	38	32	25	5	95
33981.W4010	40	9.5	5.5	10	34	11	44	38	32	25	5	90
33981.W4108	40	9.5	5.5	8	34	11	44	38	32	25	5	95
33981.W4110	40	9.5	5.5	10	34	11	44	38	32	25	5	90
33981.W0040	40	9.5	5.5	-	34	11	44	38	32	25	5	21

Order No.	l ₆	l ₇	l ₈	l ₉	w ₁	w ₂	t ₁	Type	Locking teeth	Spindle depth	Holding force kgf	Moment Mz in lock position Nm max.
33981.W4008	13	14.5	7.5	7	10	7	0.3	Black Knob	50 (7,2°)	25	70	28
33981.W4010	13	14.5	7.5	7	10	7	0.3	Black Knob	50 (7,2°)	25	70	28
33981.W4108	13	14.5	7.5	7	10	7	0.3	Orange Knob	50 (7,2°)	25	70	28
33981.W4110	13	14.5	7.5	7	10	7	0.3	Orange Knob	50 (7,2°)	25	70	28
33981.W0040	13	14.5	7.5	7	10	7	0.3	Pointer Plate	50 (7,2°)	25	70	28

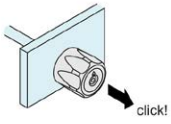

by pulling the housing until it clicks, the teeth of the knob disengage from the base.

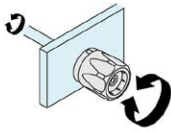

turn 33981 to rotate the spindle

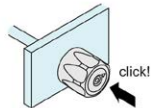

by pushing the housing until it clicks, the teeth engage again and lock the rotation of the spindle.

how to operate



How to Install

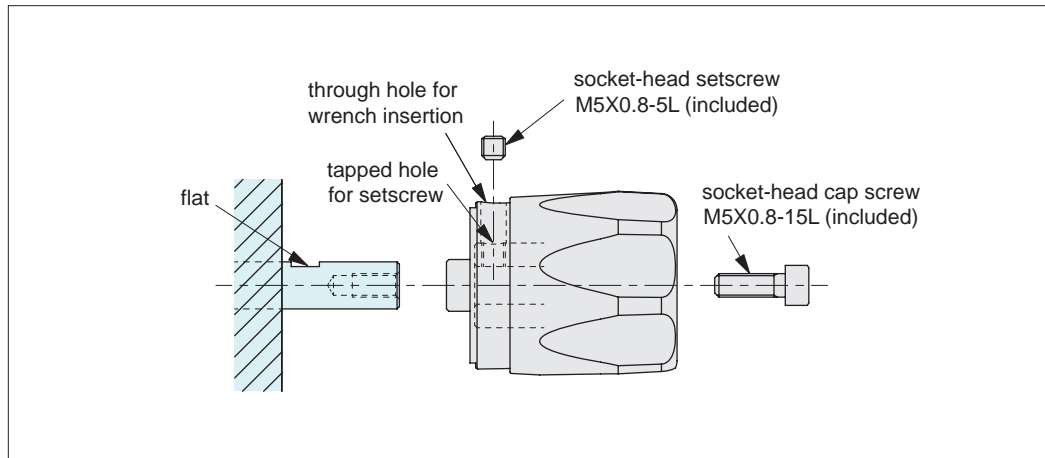

1. Pull the housing and align the through hole on the base and the tapped hole on the insert.
2. Align the flat and tapped hole on the insert and then mount the spindle.
3. Fix 33981 temporarily using M5X0.8-15L socket-head cap screw included.
4. Fix 33981 to the spindle temporarily using setscrew included.
5. Tighten M5X0.8-15L socket-head cap screw fully.
6. Tighten the setscrew fully.

Mounting Hole Dimensions

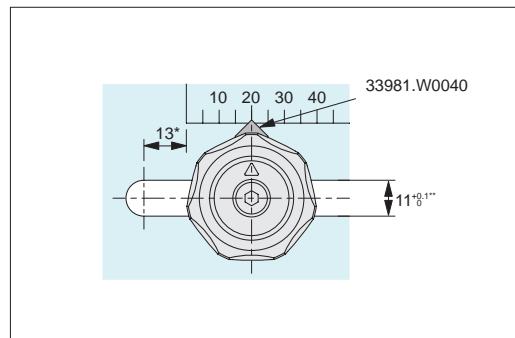
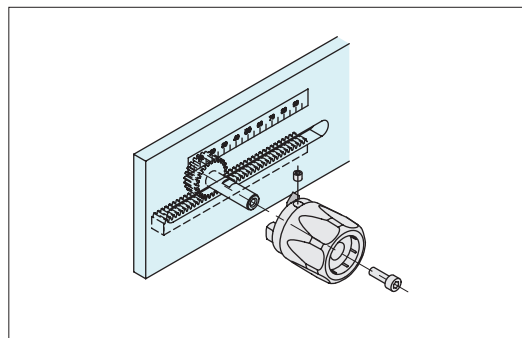

Rack and Pinion Application

*Prepare clearance of 13mm or more from the end of the required spindle stroke.
 **Recommended surface roughness is 1.6 for the inner surface of the slotted hole.

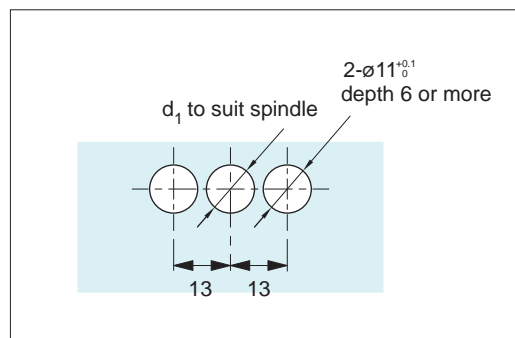
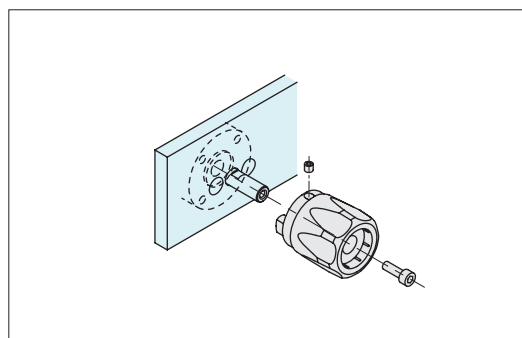

Lead Screw Application

d₁ to suit spindle

Size	d ₁
33981.W4008 / W4108	9
33981.W4010 / W4110	11

Mounting Spindle Dimension

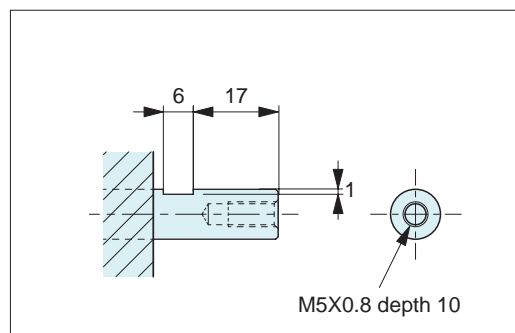
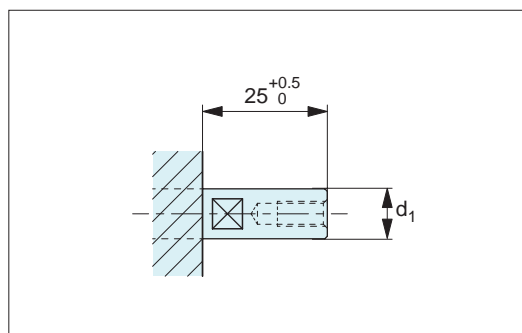

Spindle size

Size	d ₁ (g6)
33981.W4008 / W4108	8
33981.W4010 / W4110	10



Operation

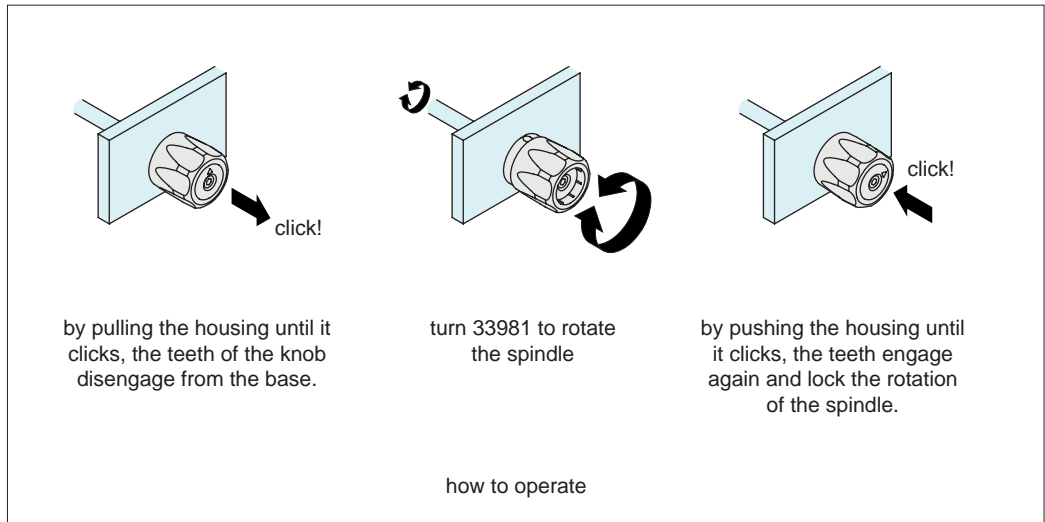

Clear Safety Indicator of Locked / Unlocked Position

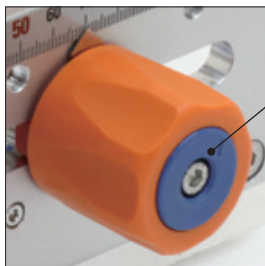

Locked

Blue indicates safety to operate machine.

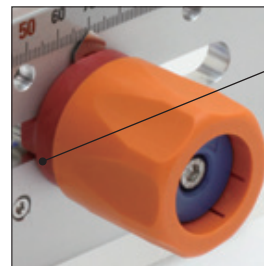

Unlocked

Red indicates caution to operate machine.

Holding Forces

One-Touch Locking Knob has 50 teeth and engages at every 7.2°. It pulls the spindle via the inner spring with 70N force to prevent chattering of spindle, with a max allowable moment at locking position of 28N·m (with 5 fold safety).

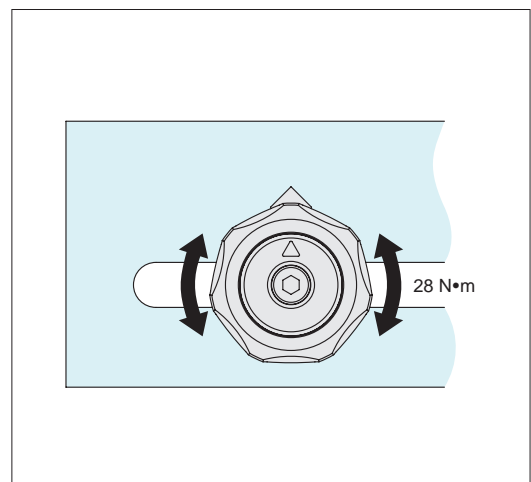
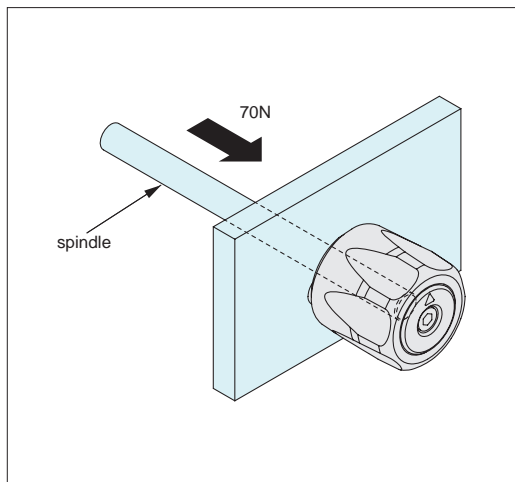

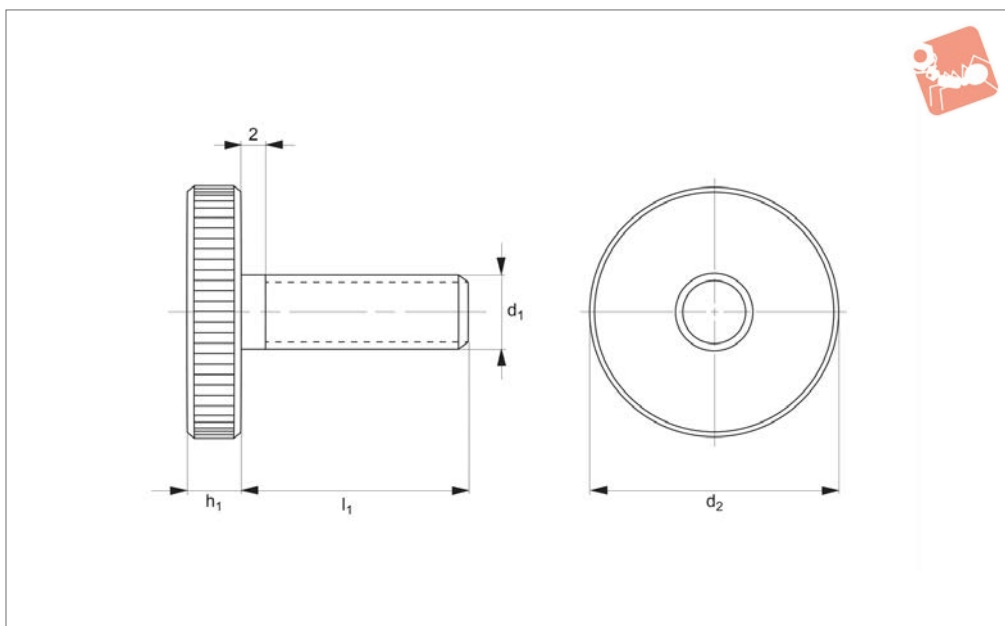

37020

THUMB SCREWS

Material

Steel, quality 5.8, blackened. Turned, visible face, good finish.

Technical Notes

All knurled screws are one-piece manufactured with thread up to the head (DIN-

designation ,A').

Order No.	d ₁	d ₂	h ₁	l ₁	Weight g
37020.W0072	M 3	12	2.5	6	2.3
37020.W0073	M 3	12	2.5	8	2.4
37020.W0074	M 3	12	2.5	10	2.5
37020.W0077	M 3	12	2.5	16	2.7
37020.W0079	M 3	12	2.5	20	2.9
37020.W0092	M 4	16	3.5	8	5.6
37020.W0093	M 4	16	3.5	10	5.7
37020.W0094	M 4	16	3.5	12	6.1
37020.W0096	M 4	16	3.5	16	6.2
37020.W0098	M 4	16	3.5	20	6.6
37020.W0100	M 4	16	3.5	25	7.0
37020.W0112	M 5	20	4.0	10	10.0
37020.W0113	M 5	20	4.0	12	11.0
37020.W0115	M 5	20	4.0	16	12.0
37020.W0117	M 5	20	4.0	20	12.0
37020.W0119	M 5	20	4.0	25	12.0
37020.W0121	M 5	20	4.0	30	13.0
37020.W0132	M 6	24	5.0	12	18.0
37020.W0134	M 6	24	5.0	16	20.0
37020.W0136	M 6	24	5.0	20	20.0
37020.W0138	M 6	24	5.0	25	20.0
37020.W0140	M 6	24	5.0	30	22.0
37020.W0142	M 6	24	5.0	40	23.0
37020.W0152	M 8	30	6.0	16	36.0
37020.W0154	M 8	30	6.0	20	37.0
37020.W0156	M 8	30	6.0	25	39.0
37020.W0158	M 8	30	6.0	30	41.0
37020.W0160	M 8	30	6.0	35	42.0
37020.W0161	M 8	30	6.0	40	44.0
37020.W0172	M10	36	8.0	20	71.0
37020.W0174	M10	36	8.0	25	72.0
37020.W0176	M10	36	8.0	30	76.0
37020.W0180	M10	36	8.0	40	80.0



37040

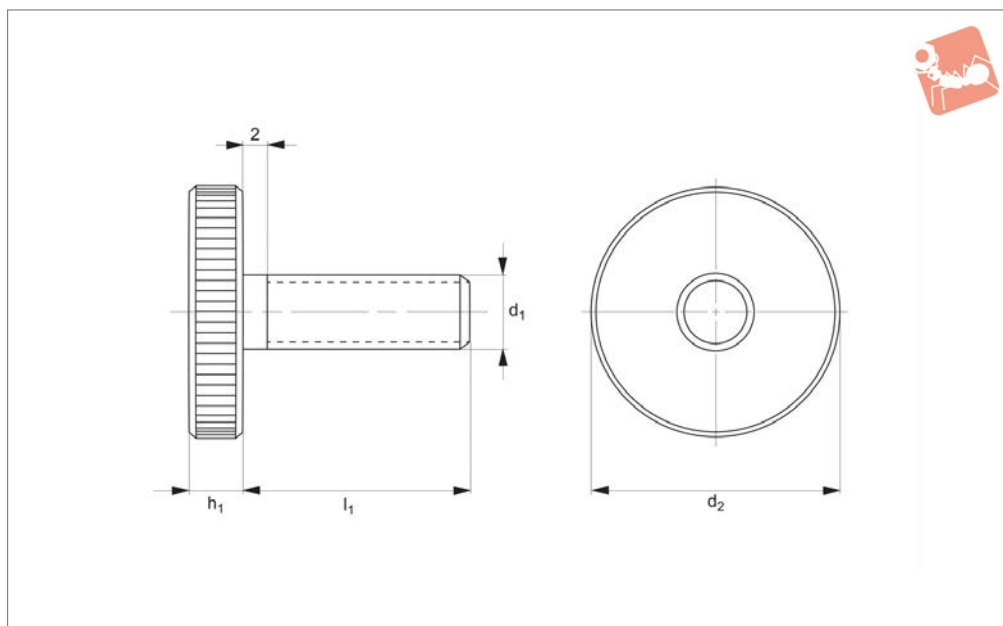

Material

Stainless steel 1.4305 (AISI 303).

tured with thread up to the head (DIN-designation ,A').

Technical Notes

All knurled screws are one-piece manufac-

Order No.	d_1	d_2	h_1	l_1	Weight g
37040.W0092	M 4	16	3.5	8	5.6
37040.W0093	M 4	16	3.5	10	5.7
37040.W0094	M 4	16	3.5	12	6.1
37040.W0096	M 4	16	3.5	16	6.2
37040.W0112	M 5	20	4.0	10	10.0
37040.W0113	M 5	20	4.0	12	11.0
37040.W0115	M 5	20	4.0	16	12.0
37040.W0117	M 5	20	4.0	20	12.0
37040.W0132	M 6	24	5.0	12	18.0
37040.W0134	M 6	24	5.0	16	20.0
37040.W0136	M 6	24	5.0	20	20.0
37040.W0138	M 6	24	5.0	25	20.0
37040.W0152	M 8	30	6.0	16	36.0
37040.W0154	M 8	30	6.0	20	37.0
37040.W0156	M 8	30	6.0	25	39.0
37040.W0158	M 8	30	6.0	30	41.0
37040.W0172	M10	36	8.0	20	71.0
37040.W0174	M10	36	8.0	25	72.0
37040.W0176	M10	36	8.0	30	76.0
37040.W0180	M10	36	8.0	40	80.0



Knurled Nuts with collar - DIN 466



Thumb Screws

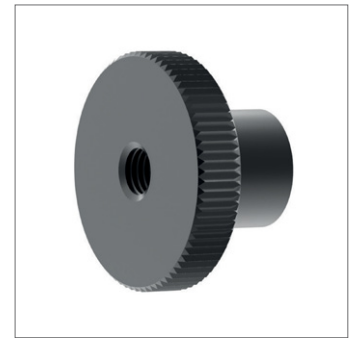
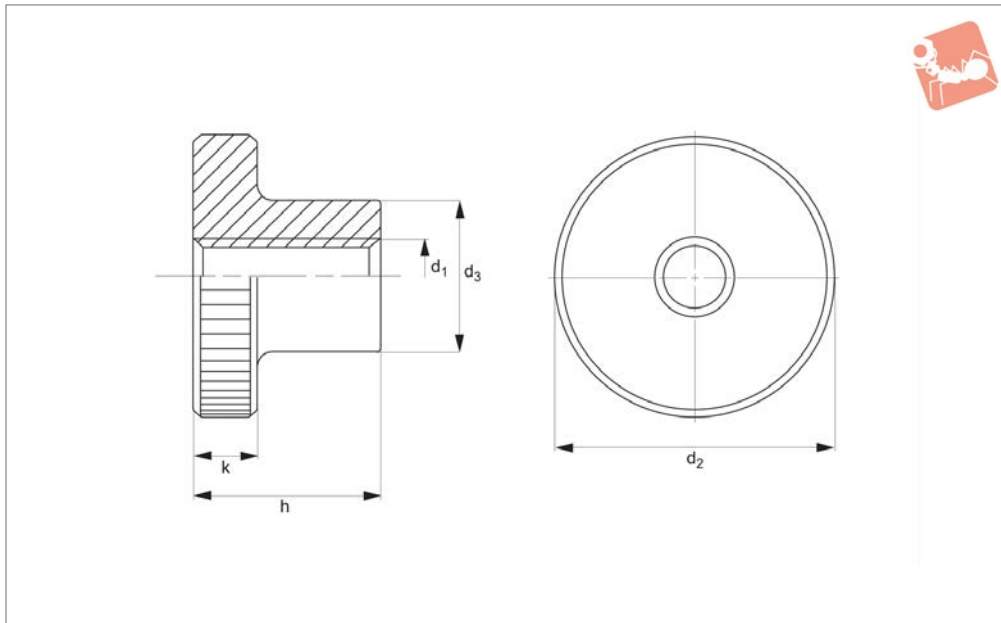

37100

THUMB SCREWS

Material

Steel, quality 5, blackened. Turned, visible face, good finish.

Technical Notes

Size M12 not contained in DIN standard.

Order No.	d ₁	d ₂	d ₃	h	k	Weight g
37100.W0003	M 3	12	6	7.5	2.5	2.9
37100.W0004	M 4	16	8	9.5	3.5	6.7
37100.W0005	M 5	20	10	11.5	4.0	12.0
37100.W0006	M 6	24	12	15.0	5.0	23.0
37100.W0008	M 8	30	16	18.0	6.0	44.0
37100.W0010	M10	36	20	23.0	8.0	85.0
37100.W0012	M12	40	22	25.0	10.0	119.0

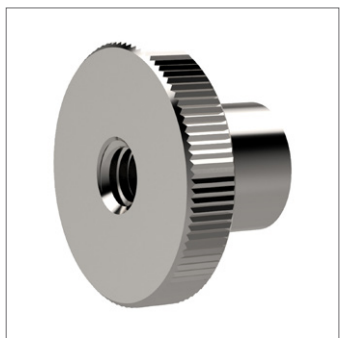

37110

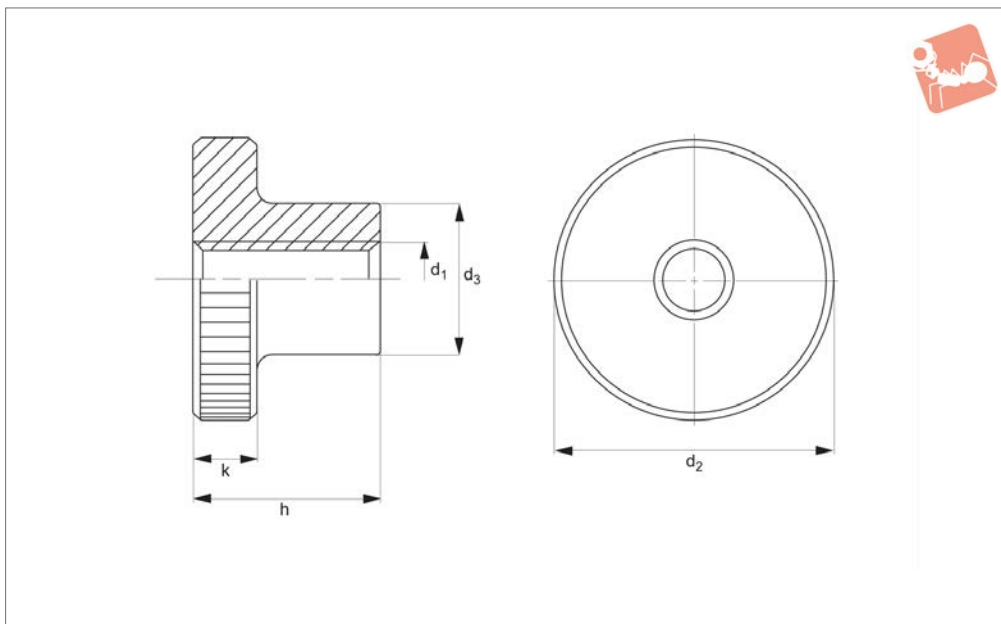

Material

Stainless steel 1.4305 (AISI 303), matte, shot-blasted.

Order No.	d ₁	d ₂	d ₃	h	k	Weight g
37110.W0002	M2,5	11	5	6.5	2.5	3.5
37110.W0003	M 3	12	6	7.5	2.5	3.5
37110.W0004	M 4	16	8	9.5	3.5	6.7
37110.W0005	M 5	20	10	11.5	4.0	12.0
37110.W0006	M 6	24	12	15.0	5.0	23.0
37110.W0008	M 8	30	16	18.0	6.0	44.0
37110.W0010	M10	36	20	23.0	8.0	85.0

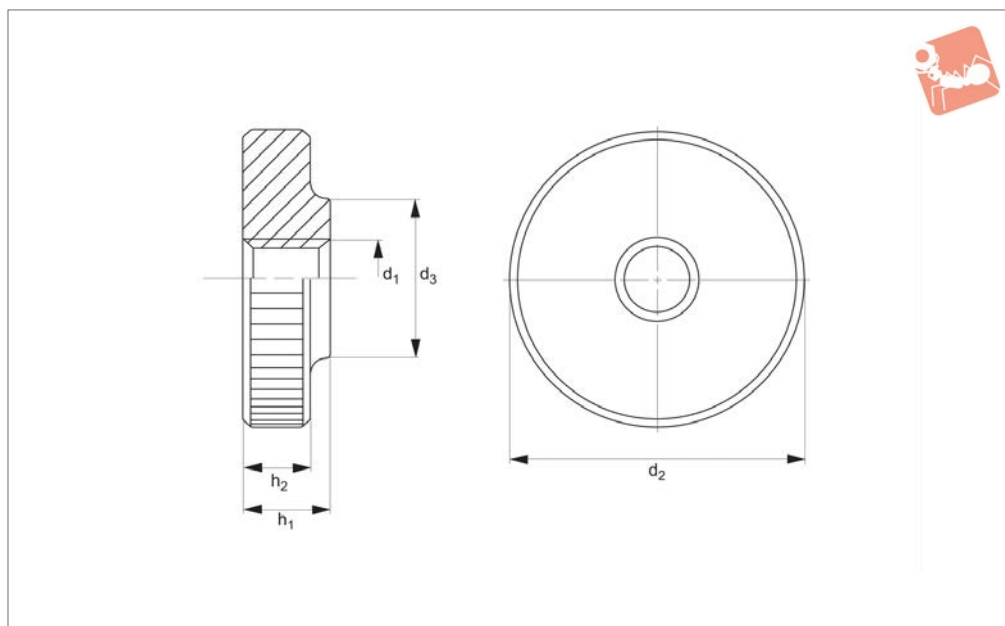
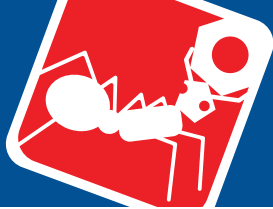

37120

THUMB SCREWS

Material

Steel, quality 5, blackened. Turned, visible face, good finish.

Technical Notes

Size M12 not contained in DIN standard.

Order No.	d ₁	d ₂	d ₃	h ₁	h ₂	Weight g
37120.W0003	M 3	12	6	3	2.5	2.1
37120.W0004	M 4	16	8	4	3.5	5.0
37120.W0005	M 5	20	10	5	4.0	9.4
37120.W0006	M 6	24	12	6	5.0	17.0
37120.W0008	M 8	30	16	8	6.0	32.0
37120.W0010	M10	36	20	10	8.0	61.0
37120.W0012	M12	40	22	12	10.0	92.0

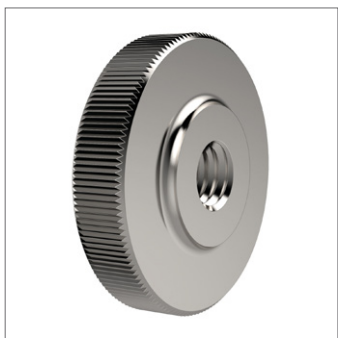

37130

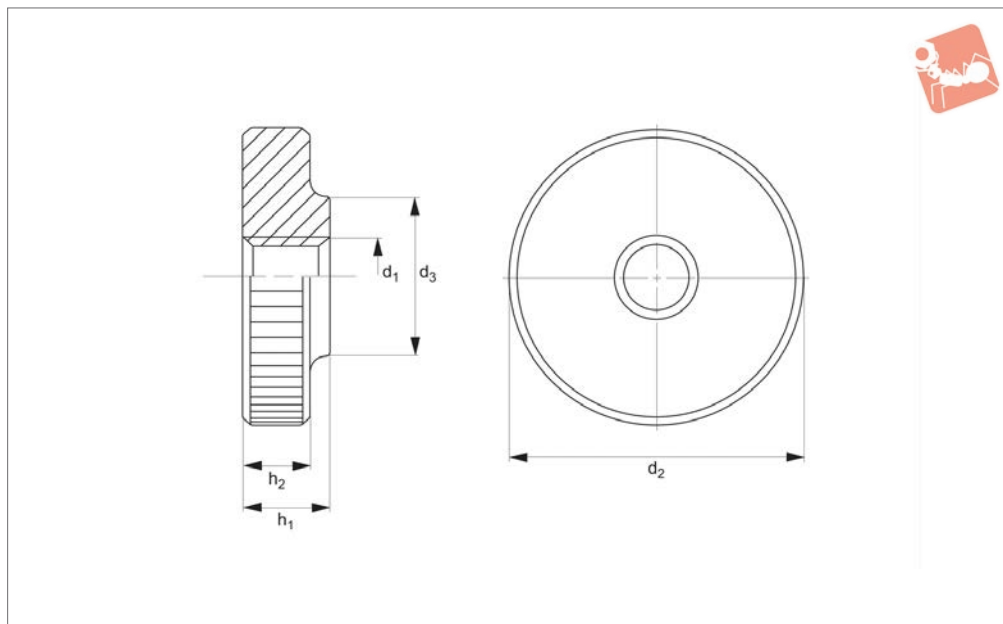

Material

Stainless steel 1,4305 (AISI 303), dull blasted.

Order No.	d ₁	d ₂	d ₃	h ₁	h ₂	Weight g
37130.W0003	M 3	12	6	3	2.5	2.1
37130.W0004	M 4	16	8	4	3.5	5.0
37130.W0005	M 5	20	10	5	4.0	9.4
37130.W0006	M 6	24	12	6	5.0	17.0
37130.W0008	M 8	30	16	8	6.0	32.0
37130.W0010	M10	36	20	10	8.0	61.0



Knurled Thumb Screws

DIN 464

Thumb Screws

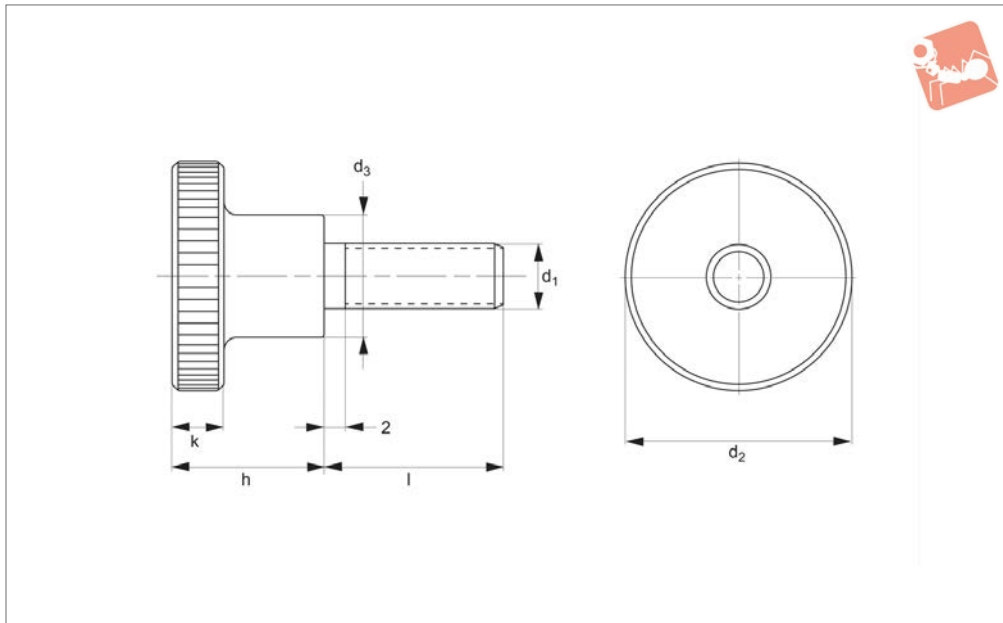

37140

THUMB SCREWS

Material

Steel, quality 5.8, blackened. Turned, visible face, good finish.

Contra-ry to the Official Standard Sheet, they all have a thread up to the head, as shown, but no recess at the thread end.

Technical Notes

All knurled screws are one-piece manufac-

Order No.	d ₁	d ₂	d ₃	h	k	l	Weight g
37140.W0031	M 3	12	6	7.5	2.5	6	3.7
37140.W0032	M 3	12	6	7.5	2.5	10	3.8
37140.W0033	M 3	12	6	7.5	2.5	12	4.0
37140.W0034	M 3	12	6	7.5	2.5	16	4.0
37140.W0040	M 4	16	8	9.5	3.5	5	7.7
37140.W0041	M 4	16	8	9.5	3.5	8	7.9
37140.W0042	M 4	16	8	9.5	3.5	10	8.1
37140.W0043	M 4	16	8	9.5	3.5	12	8.3
37140.W0044	M 4	16	8	9.5	3.5	16	8.4
37140.W0045	M 4	16	8	9.5	3.5	20	9.1
37140.W0046	M 4	16	8	9.5	3.5	25	9.0
37140.W0051	M 5	20	10	11.5	4.0	6	14.0
37140.W0052	M 5	20	10	11.5	4.0	8	15.0
37140.W0053	M 5	20	10	11.5	4.0	10	15.0
37140.W0054	M 5	20	10	11.5	4.0	12	15.0
37140.W0055	M 5	20	10	11.5	4.0	16	16.0
37140.W0056	M 5	20	10	11.5	4.0	20	16.0
37140.W0057	M 5	20	10	11.5	4.0	25	17.0
37140.W0058	M 5	20	10	11.5	4.0	30	17.0
37140.W0061	M 6	24	12	15.0	5.0	8	28.0
37140.W0062	M 6	24	12	15.0	5.0	10	27.0
37140.W0063	M 6	24	12	15.0	5.0	12	28.0
37140.W0064	M 6	24	12	15.0	5.0	16	28.0
37140.W0065	M 6	24	12	15.0	5.0	20	29.0
37140.W0066	M 6	24	12	15.0	5.0	25	30.0
37140.W0067	M 6	24	12	15.0	5.0	30	31.0
37140.W0068	M 6	24	12	15.0	5.0	35	31.0
37140.W0081	M 8	30	16	18.0	6.0	12	53.0
37140.W0082	M 8	30	16	18.0	6.0	16	55.0
37140.W0083	M 8	30	16	18.0	6.0	20	56.0
37140.W0084	M 8	30	16	18.0	6.0	25	58.0
37140.W0085	M 8	30	16	18.0	6.0	30	60.0



Order No.	d ₁	d ₂	d ₃	h	k	l	Weight g
37140.W0086	M 8	30	16	18.0	6.0	35	50.0
37140.W0087	M 8	30	16	18.0	6.0	40	61.0
37140.W0101	M10	36	20	23.0	8.0	20	106.0
37140.W0102	M10	36	20	23.0	8.0	25	109.0
37140.W0103	M10	36	20	23.0	8.0	30	112.0
37140.W0104	M10	36	20	23.0	8.0	35	116.0
37140.W0105	M10	36	20	23.0	8.0	40	116.0



Knurled Thumb Screws

stainless steel - DIN 464

Thumb Screws

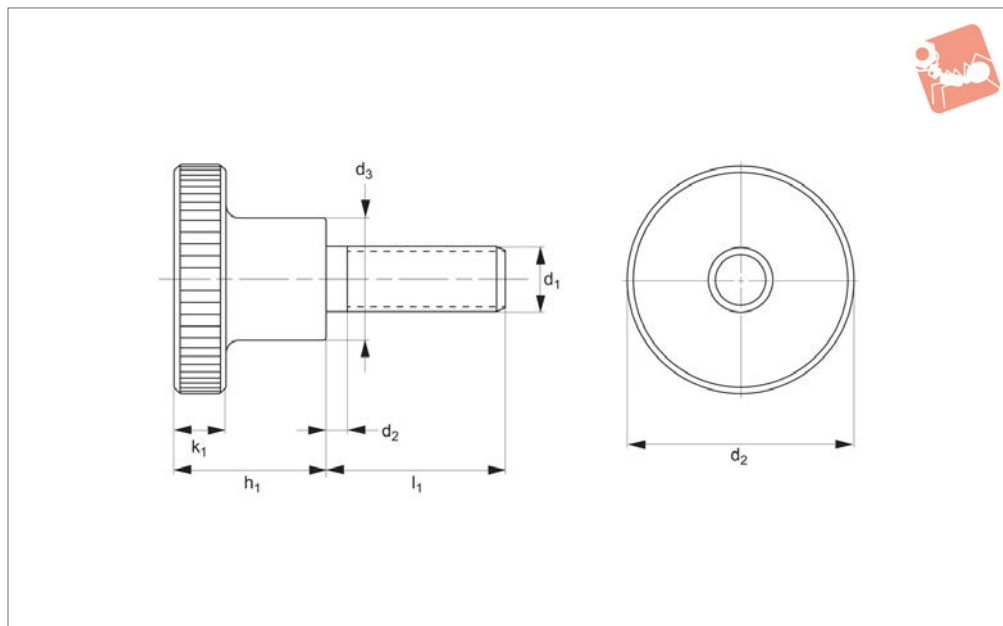

37150

THUMB SCREWS

Material

Stainless steel 1.4305 (AISI 303), matte, shot-blasted.

Conary to the Official Standard Sheet, they all have a thread up to the head, as shown, but no recess at the thread end.

Technical Notes

All knurled screws are one-piece manufac-

Order No.	d ₁	d ₂	d ₃	h ₁	k ₁	l ₁	Weight g
37150.W0031	M 3	12	6	7.5	2.5	6	3.7
37150.W0032	M 3	12	6	7.5	2.5	10	3.8
37150.W0033	M 3	12	6	7.5	2.5	12	4.0
37150.W0034	M 3	12	6	7.5	2.5	16	4.0
37150.W0041	M 4	16	8	9.5	3.5	8	7.9
37150.W0042	M 4	16	8	9.5	3.5	10	8.1
37150.W0043	M 4	16	8	9.5	3.5	12	8.3
37150.W0044	M 4	16	8	9.5	3.5	16	8.4
37150.W0045	M 4	16	8	9.5	3.5	20	9.1
37150.W0046	M 4	16	8	9.5	3.5	25	9.0
37150.W0051	M 5	20	10	11.5	4.0	10	15.0
37150.W0052	M 5	20	10	11.5	4.0	12	15.0
37150.W0053	M 5	20	10	11.5	4.0	16	16.0
37150.W0054	M 5	20	10	11.5	4.0	20	16.0
37150.W0055	M 5	20	10	11.5	4.0	25	17.0
37150.W0058	M 5	20	10	11.5	4.0	30	17.0
37150.W0061	M 6	24	12	15.0	5.0	12	28.0
37150.W0062	M 6	24	12	15.0	5.0	16	28.0
37150.W0063	M 6	24	12	15.0	5.0	20	29.0
37150.W0064	M 6	24	12	15.0	5.0	25	30.0
37150.W0065	M 6	24	12	15.0	5.0	30	31.0
37150.W0068	M 6	24	12	15.0	5.0	35	31.0
37150.W0081	M 8	30	16	18.0	6.0	16	55.0
37150.W0082	M 8	30	16	18.0	6.0	20	56.0
37150.W0083	M 8	30	16	18.0	6.0	25	58.0
37150.W0084	M 8	30	16	18.0	6.0	30	60.0
37150.W0086	M 8	30	16	18.0	6.0	35	50.0



37160

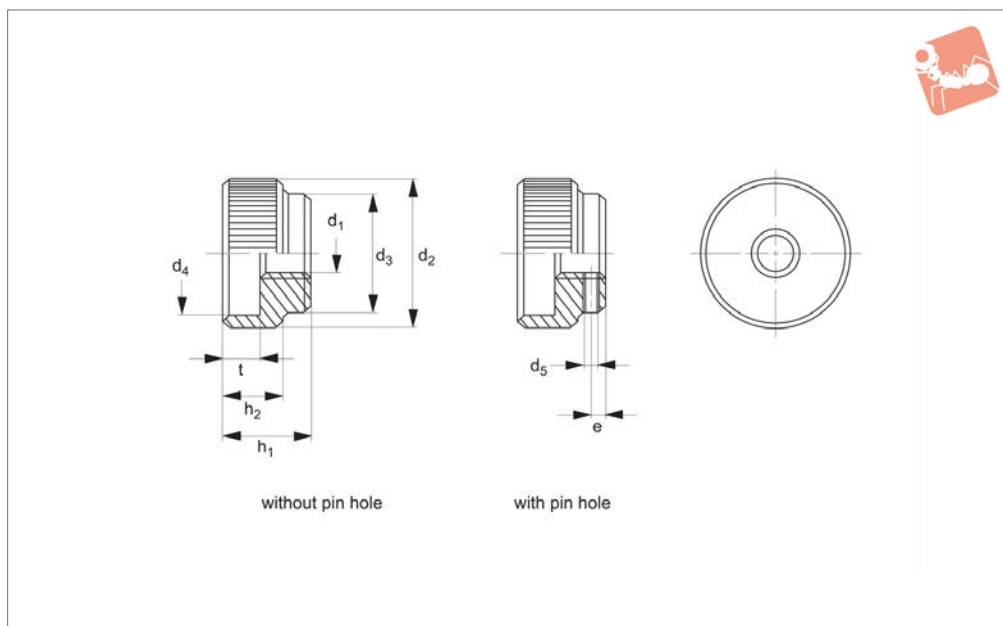

Material

Free-cutting steel, blackened.

Technical Notes

Tolerance of pin hole d_5 is H7.

Order No.	Type	d_1	d_2	d_3	d_4	d_5 pre-drilled	e	h_1	h_2	t	Pin required DIN 7	Weight g
37160.W0005	Without Pin Hole	M 5	20	14	15	-	-	12	8	5	-	16
37160.W0006	Without Pin Hole	M 6	24	16	18	-	-	14	10	6	-	27
37160.W0008	Without Pin Hole	M 8	30	20	24	-	-	17	12	7	-	46
37160.W0010	Without Pin Hole	M10	36	28	30	-	-	20	14	8	-	82
37160.W0012	Without Pin Hole	M12	40	32	34	-	-	24	16	10	-	123
37160.W0105	With Pin Hole	M 5	20	14	15	1.4	2.5	12	8	5	1,5 M 6x14	15
37160.W0106	With Pin Hole	M 6	24	16	18	1.4	2.5	14	10	6	1,5 M 6x16	25
37160.W0108	With Pin Hole	M 8	30	20	24	1.9	3.0	17	12	7	2,0 M 6x20	45
37160.W0110	With Pin Hole	M10	36	28	30	2.9	4.0	20	14	8	3,0 M 6x28	86
37160.W0112	With Pin Hole	M12	40	32	34	3.9	4.0	24	16	10	4,0 M 6x32	121



Knurled Nuts

stainless steel - DIN 6303



Thumb Screws

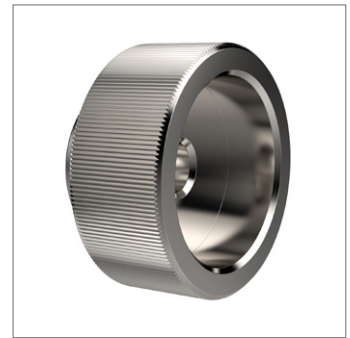
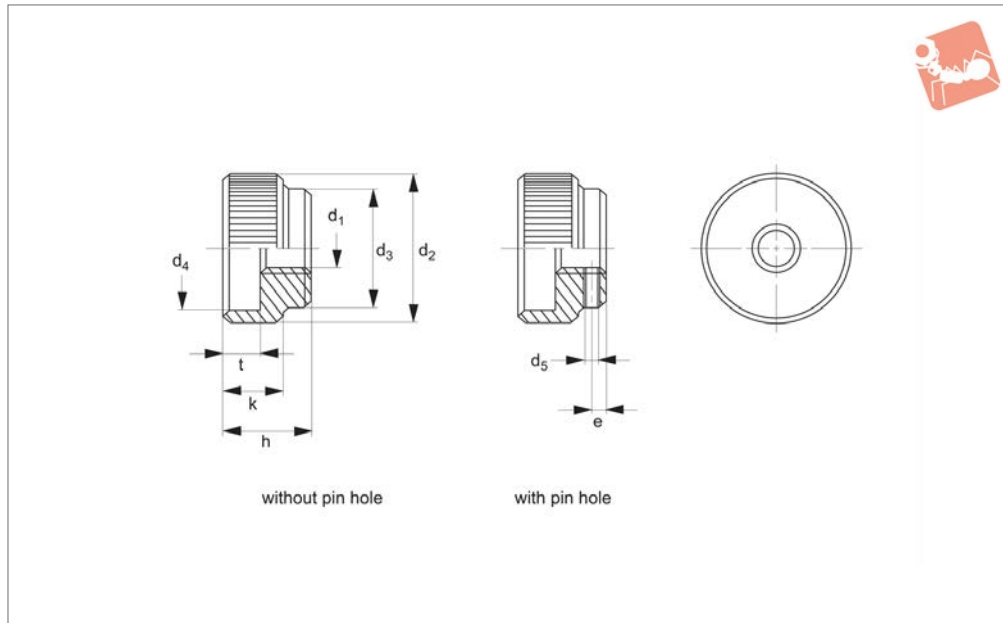

37170

THUMB SCREWS

Material

Stainless steel 1.4305 (AISI 303), matte, shot-blasted.

Technical Notes

Tolerance of pin hole d_5 is H7.

Order No.	Type	d_1	d_2	d_3	d_4	d_5 pre-drilled	e	h	k	t	Pin required DIN 7	Weight g
37170.W0005	Without Pin Hole	M 5	20	14	15	-	-	12	8	5	-	16
37170.W0006	Without Pin Hole	M 6	24	16	18	-	-	14	10	6	-	27
37170.W0008	Without Pin Hole	M 8	30	20	24	-	-	17	12	7	-	46
37170.W0010	Without Pin Hole	M10	36	28	30	-	-	20	14	8	-	82
37170.W0012	Without Pin Hole	M12	40	32	34	-	-	24	16	10	-	123
37170.W0105	With Pin Hole	M 5	20	14	15	1.4	2.5	12	8	5	1,5 M 6x14	15
37170.W0106	With Pin Hole	M 6	24	16	18	1.4	2.5	14	10	6	1,5 M 6x16	25
37170.W0108	With Pin Hole	M 8	30	20	24	1.9	3.0	17	12	7	2,0 M 6x20	45
37170.W0110	With Pin Hole	M10	36	28	30	2.9	4.0	20	14	8	3,0 M 6x28	86
37170.W0112	With Pin Hole	M12	40	32	34	3.9	4.0	24	16	10	4,0 M 6x32	121



37200

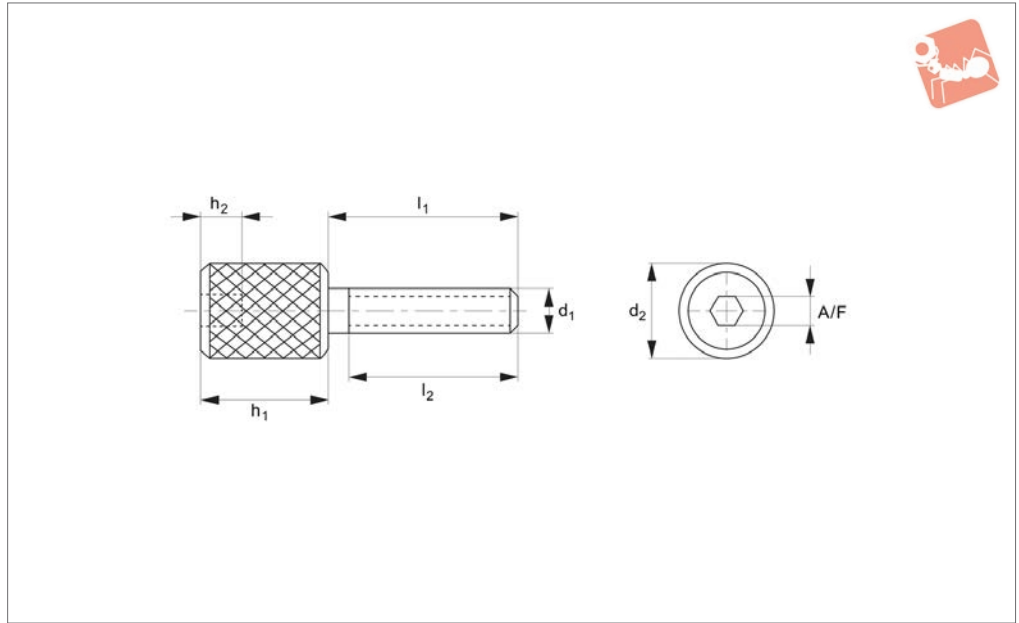

Material

Stainless steel (AISI 303, 1.4305).
Tensile strength 550 N/mm².
Proof stress min. 190 N/mm², austenitic

stainless steel.

Technical Notes

Stainless steel 303 series is a hard stain-

less steel which may (in harsh conditions) exhibit slight signs of rusting. Typically used in food and pharmaceutical applications.

Order No.	d ₁	l ₁	d ₂	l ₂	h ₁	h ₂ min.	A/F
37200.W0001	M 3	12	6	11	12	2	2
37200.W0002	M 3	20	6	16	12	2	2
37200.W0003	M 3	12	8	11	12	2	2
37200.W0004	M 3	20	8	16	12	2	2
37200.W0005	M 3	10	10	8	12	3	3
37200.W0006	M 3	12	10	11	12	3	3
37200.W0015	M 4	12	6	11	12	2	2
37200.W0016	M 4	20	6	16	12	2	2
37200.W0017	M 4	25	6	20	12	2	2
37200.W0018	M 4	12	8	11	12	2	2
37200.W0019	M 4	20	8	16	12	2	2
37200.W0020	M 4	25	8	20	12	2	2
37200.W0021	M 4	10	10	8	12	3	3
37200.W0022	M 4	14	10	12	12	3	3
37200.W0023	M 5	12	8	11	12	2	2
37200.W0024	M 5	20	8	16	12	2	2
37200.W0025	M 5	25	8	20	12	2	2
37200.W0026	M 5	32	8	25	12	2	2
37200.W0027	M 5	12	10	11	12	3	3
37200.W0028	M 5	20	10	16	12	3	3
37200.W0029	M 5	25	10	20	12	3	3
37200.W0030	M 5	32	10	25	12	3	3

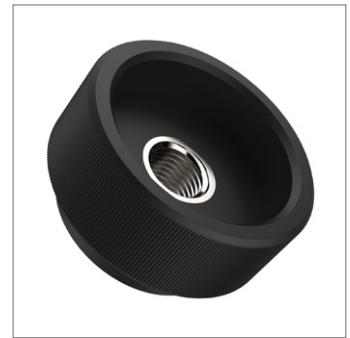
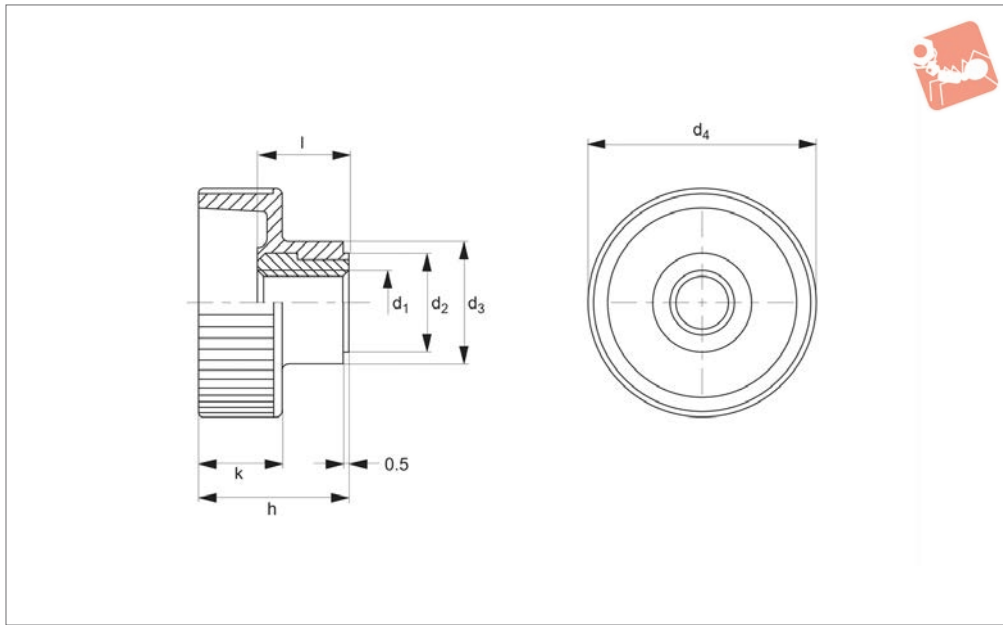

37330

THUMB SCREWS

Material

Body: thermoplastic (PA), black. Insert: steel, galvanised or stainless steel 1.4305

(AISI 303).

80°C.

Technical Notes

Temperature resistant from -30°C to +

Order No.	Type	d ₁	d ₂	d ₃	d ₄	h	k	l	Weight g
37330.W0004	Steel Insert	M 4	9	12	19	14.0	8.0	9.0	4.5
37330.W0005	Steel Insert	M 5	9	12	19	14.0	8.0	9.0	4.0
37330.W0006	Steel Insert	M 6	12	14	24	16.5	9.5	10.5	7.0
37330.W0008	Steel Insert	M 8	14	16	30	19.5	11.0	11.5	10.0
37330.W0010	Steel Insert	M10	16	18	36	22.5	12.5	14.0	15.0
37330.W0505	Stainless Insert	M 5	9	12	19	14.0	8.0	9.0	4.0
37330.W0506	Stainless Insert	M 6	12	14	24	16.5	9.5	10.5	7.0
37330.W0508	Stainless Insert	M 8	14	16	30	19.5	11.0	11.5	10.0



37352

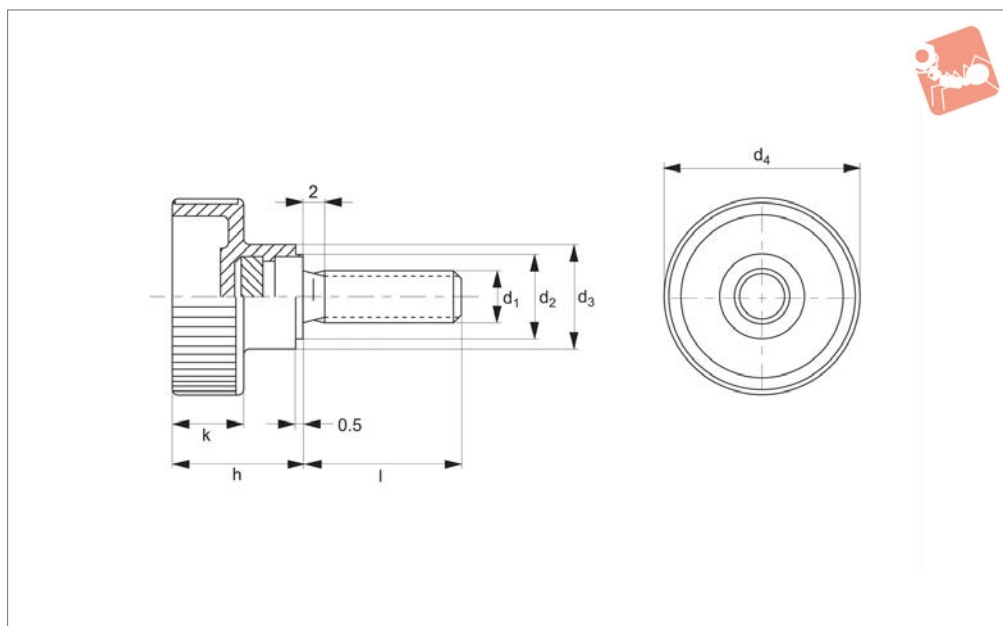

Material

Handle: thermoplastic PA, black.
Screw: steel, galvanised

Technical Notes

Temperature range from -30°C up to +80°C.

Order No.	d ₁	d ₂	d ₃	d ₄	h	k	l	Weight g
37352.W0030	M 4	9	12	19	14.0	8.0	10	4.0
37352.W0032	M 4	9	12	19	14.0	8.0	15	6.0
37352.W0034	M 4	9	12	19	14.0	8.0	20	7.0
37352.W0036	M 4	9	12	19	14.0	8.0	30	7.0
37352.W0042	M 5	9	12	19	14.0	8.0	10	6.0
37352.W0043	M 5	9	12	19	14.0	8.0	15	5.0
37352.W0045	M 5	9	12	19	14.0	8.0	20	7.0
37352.W0046	M 5	9	12	19	14.0	8.0	25	8.0
37352.W0050	M 6	12	14	24	16.5	9.5	10	7.0
37352.W0053	M 6	12	14	24	16.5	9.5	16	8.0
37352.W0054	M 6	12	14	24	16.5	9.5	20	12.0
37352.W0055	M 6	12	14	24	16.5	9.5	25	9.0
37352.W0057	M 6	12	14	24	16.5	9.5	30	13.0
37352.W0060	M 8	14	16	30	19.5	11.0	16	14.0
37352.W0062	M 8	14	16	30	19.5	11.0	20	16.0
37352.W0064	M 8	14	16	30	19.5	11.0	25	17.0
37352.W0065	M 8	14	16	30	19.5	11.0	30	23.0
37352.W0067	M 8	14	16	30	19.5	11.0	40	20.0
37352.W0070	M10	16	18	36	22.5	12.5	20	30.0
37352.W0072	M10	16	18	36	22.5	12.5	25	31.0
37352.W0074	M10	16	18	36	22.5	12.5	30	33.0
37352.W0076	M10	16	18	36	22.5	12.5	40	38.0



Knurled Thumb Screws

plastic - stainless steel grub screw

Thumb Screws

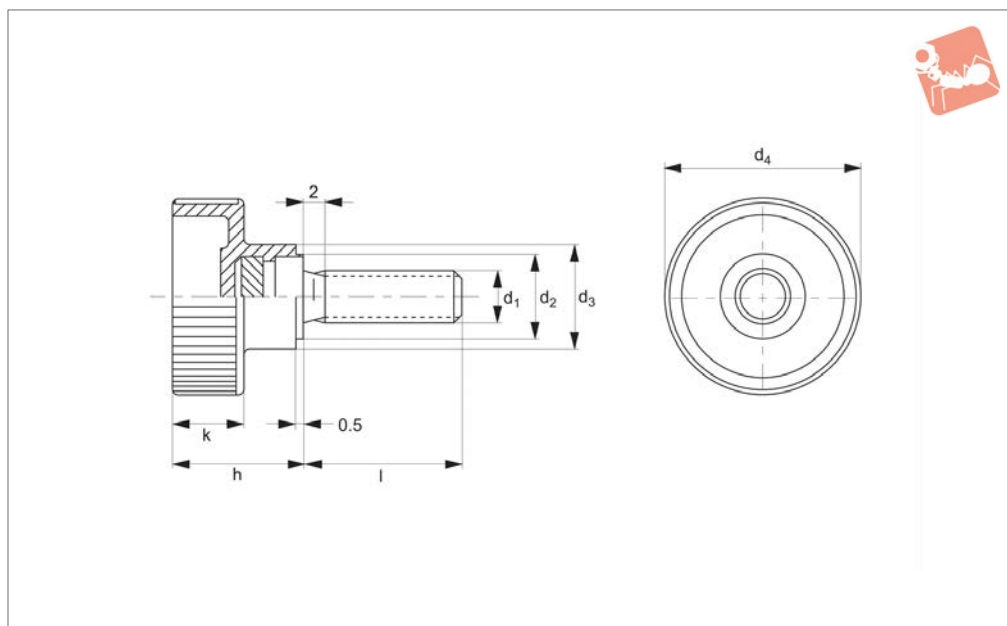

37354

THUMB SCREWS

Material

Handle: thermoplastic PA, black.

Screw: stainless steel 1.4567. (AISI 304)

Technical Notes

Temperature range from -30°C up to +80°C.

Order No.	d ₁	d ₂	d ₃	d ₄	h	k	l	Weight g
37354.W0242	M 5	9	12	19	14.0	8.0	10	4.3
37354.W0243	M 5	9	12	19	14.0	8.0	15	5.0
37354.W0245	M 5	9	12	19	14.0	8.0	20	5.5
37354.W0246	M 5	9	12	19	14.0	8.0	25	6.0
37354.W0250	M 6	12	14	24	16.5	9.5	10	7.0
37354.W0253	M 6	12	14	24	16.5	9.5	16	8.0
37354.W0254	M 6	12	14	24	16.5	9.5	20	9.0
37354.W0255	M 6	12	14	24	16.5	9.5	25	9.0
37354.W0257	M 6	12	14	24	16.5	9.5	30	10.0
37354.W0262	M 8	14	16	30	19.5	11.0	20	16.0
37354.W0264	M 8	14	16	30	19.5	11.0	25	17.0
37354.W0265	M 8	14	16	30	19.5	11.0	30	19.0
37354.W0267	M 8	14	16	30	19.5	11.0	40	20.0
37354.W0270	M10	16	18	36	22.5	12.5	20	30.0
37354.W0272	M10	16	18	36	22.5	12.5	25	31.0
37354.W0274	M10	16	18	36	22.5	12.5	30	33.0
37354.W0278	M 10	16	18	36	22.5	12.5	45	43.0
37354.W0280	M 10	16	18	36	22.5	12.5	55	48.0

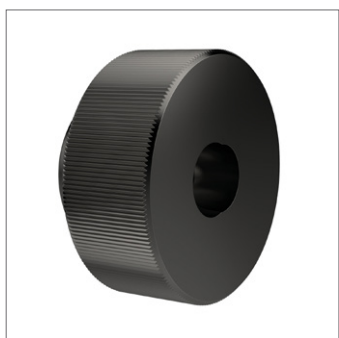

37360

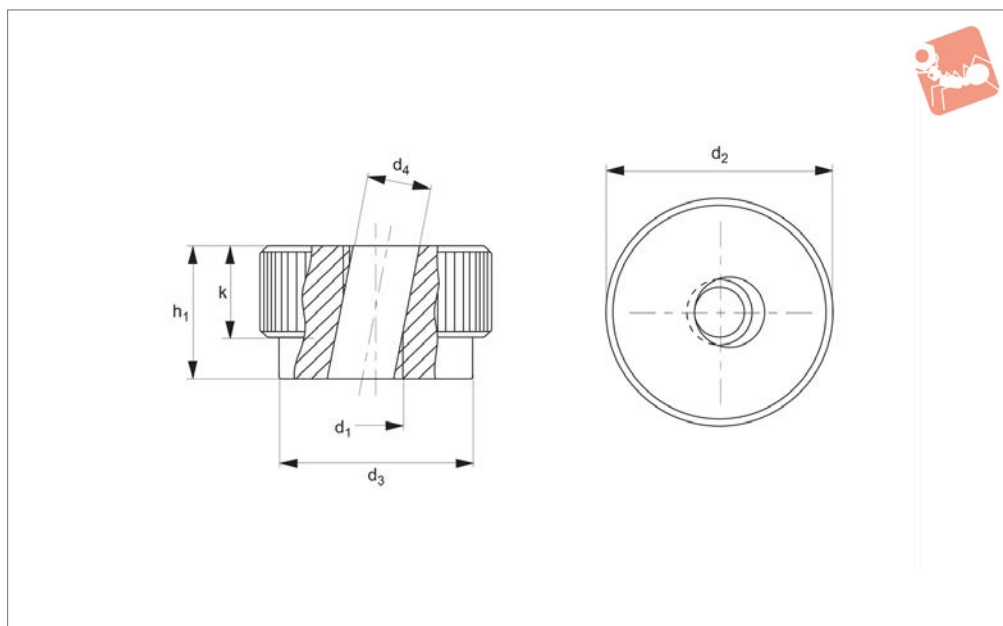

Material

Turned and burnished steel, blackened.
Tensile strength class 5.

Technical Notes

These knurled knobs are used when quick

tightening is required and with only a slight clamping force. The knob is inserted obliquely on the threaded stud and then placed in the axial position so that it fits onto the stud threads. At this point it can

be locked with just a slight rotation.

Order No.	d ₁	d ₂	d ₃	d ₄	h ₁	k	Weight g
37360.W0006	M_6	24	16	6.7	14	10	35
37360.W0008	M_8	30	20	8.7	17	12	70
37360.W0010	M10	36	28	11.0	20	14	120
37360.W0012	M12	40	32	13	24	16	145



Wide Selection of Thumb Screws, Knurled Screws & Wing Nuts



Positioning Elements

THUMB SCREWS



37020 - Steel flat knurled screw



37040 - Stainless steel flat knurled screw

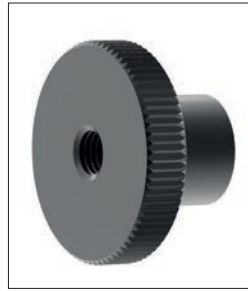

37100 - Steel knurled nut with collar

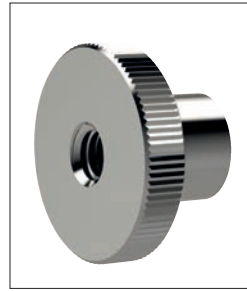

37110 - Stainless steel knurled nut with collar

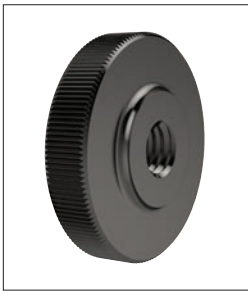

37120 - Steel flat knurled nut



37130 - Stainless steel flat knurled nut



37140 - Steel knurled screw with collar



37150 - Stainless steel knurled screw with collar



37160 - Steel knurled nut

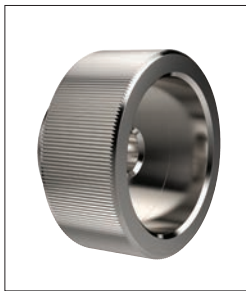

37170 - Stainless steel knurled nut



37200 - Stainless steel knurled thumb screw



37330 - Plastic knurled nut



37352 - Plastic knurled steel screw



37354 - Plastic knurled stainless steel screw



37380 - 1/4 turn screw



37400 - 1/4 turn nut



37460 - Thumb knob



37460

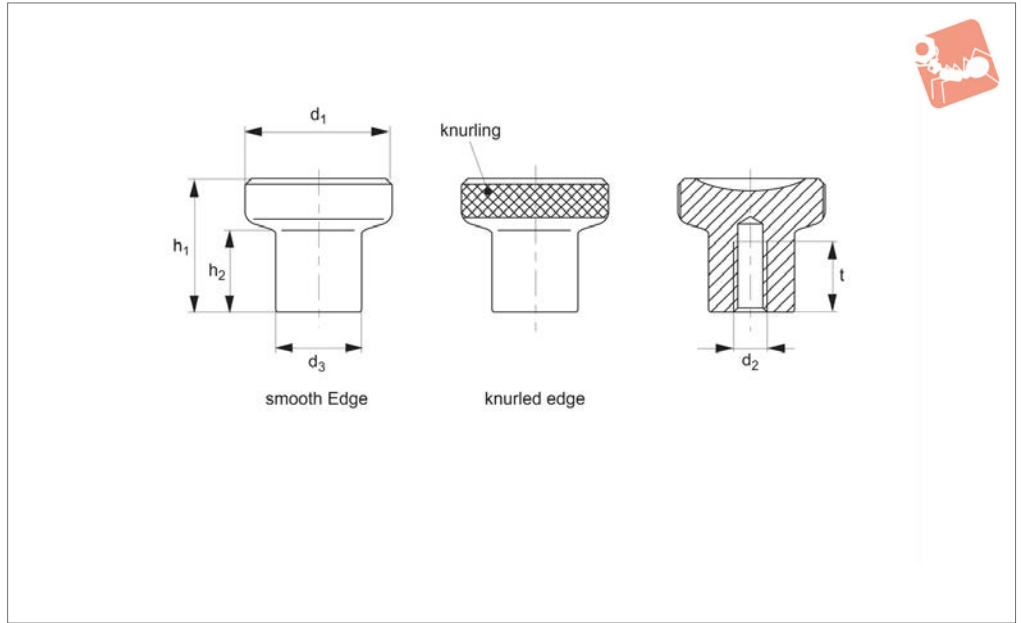

Material

Steel, blackened.
Stainless steel 1.4305 (AISI 303),

Matte finish.

Important Notes

Stainless steel knobs are used in applica-

tions where a push or pull movement is required.

Order No.	Edge finish	Finish	d ₁	d ₂	d ₃	h ₁	h ₂	t min.	Weight g
37460.W0242	Knurled	Steel	21	M 4	12.5	18.0	10.5	10	26
37460.W0042	Knurled	Stainless	21	M 4	12.5	18.0	10.5	10	26
37460.W0252	Knurled	Steel	21	M 5	12.5	18.0	10.5	10	25
37460.W0052	Knurled	Stainless	21	M 5	12.5	18.0	10.5	10	25
37460.W0264	Knurled	Steel	25	M 6	14.5	22.5	14.0	12	42
37460.W0064	Knurled	Stainless	25	M 6	14.5	22.5	14.0	12	42
37460.W0284	Knurled	Steel	25	M 8	14.5	22.5	14.0	12	39
37460.W0084	Knurled	Stainless	25	M 8	14.5	22.5	14.0	12	39
37460.W0288	Knurled	Steel	31	M 8	18.5	27.0	17.0	15	75
37460.W0088	Knurled	Stainless	31	M 8	18.5	27.0	17.0	15	75
37460.W0308	Knurled	Steel	31	M10	18.5	27.0	17.0	17	70
37460.W0108	Knurled	Stainless	31	M10	18.5	27.0	17.0	17	70
37460.W0642	Smooth	Steel	21	M 4	12.5	18.0	10.5	10	26
37460.W0542	Smooth	Stainless	21	M 4	12.5	18.0	10.5	10	26
37460.W0752	Smooth	Steel	21	M 5	12.5	18.0	10.5	10	25
37460.W0552	Smooth	Stainless	21	M 5	12.5	18.0	10.5	10	25
37460.W0764	Smooth	Steel	25	M 6	14.5	22.5	14.0	12	42
37460.W0564	Smooth	Stainless	25	M 6	14.5	22.5	14.0	12	42
37460.W0784	Smooth	Steel	25	M 8	14.5	22.5	14.0	12	39
37460.W0584	Smooth	Stainless	25	M 8	14.5	22.5	14.0	12	39
37460.W0788	Smooth	Steel	31	M 8	18.5	27.0	17.0	15	75
37460.W0588	Smooth	Stainless	31	M 8	18.5	27.0	17.0	15	75
37460.W0808	Smooth	Steel	31	M10	18.5	27.0	17.0	17	70
37460.W0608	Smooth	Stainless	31	M10	18.5	27.0	17.0	17	70



Wide Selection of Thumb Screws, Knurled Screws & Wing Nuts



Positioning Elements

THUMB SCREWS



37020 - Steel flat knurled screw



37040 - Stainless steel flat knurled screw

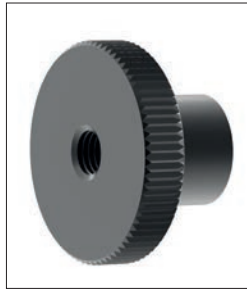

37100 - Steel knurled nut with collar

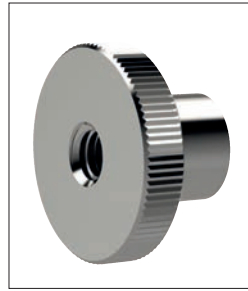

37110 - Stainless steel knurled nut with collar

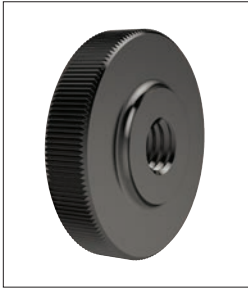

37120 - Steel flat knurled nut



37130 - Stainless steel flat knurled nut



37140 - Steel knurled screw with collar



37150 - Stainless steel knurled screw with collar



37160 - Steel knurled nut

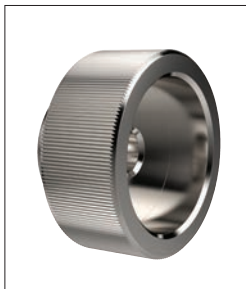

37170 - Stainless steel knurled nut



37200 - Stainless steel knurled thumb screw

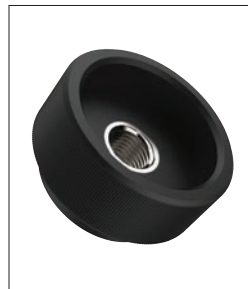

37330 - Plastic knurled nut



37352 - Plastic knurled steel screw



37354 - Plastic knurled stainless steel screw



37380 - 1/4 turn screw



37400 - 1/4 turn nut



37460 - Thumb knob



72180 - Plastic wing nut



72190 - Plastic wing nut
with screw



72210 - Plastic wing nuts



72270 - 1/4 turn nut



72280 - 1/4 turn nut



72290 - 1/4 turn screw



72300 - 1/4 turn screw

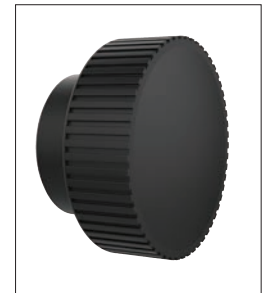

72410 - Knurled knob



72430 - Knurled knob
with screw



72440 - Knurled knobs



72460 - Knurled knobs



73200 - Mushroom knobs



Tommy Screws with fixed bar - DIN 6304

Thumb Screws

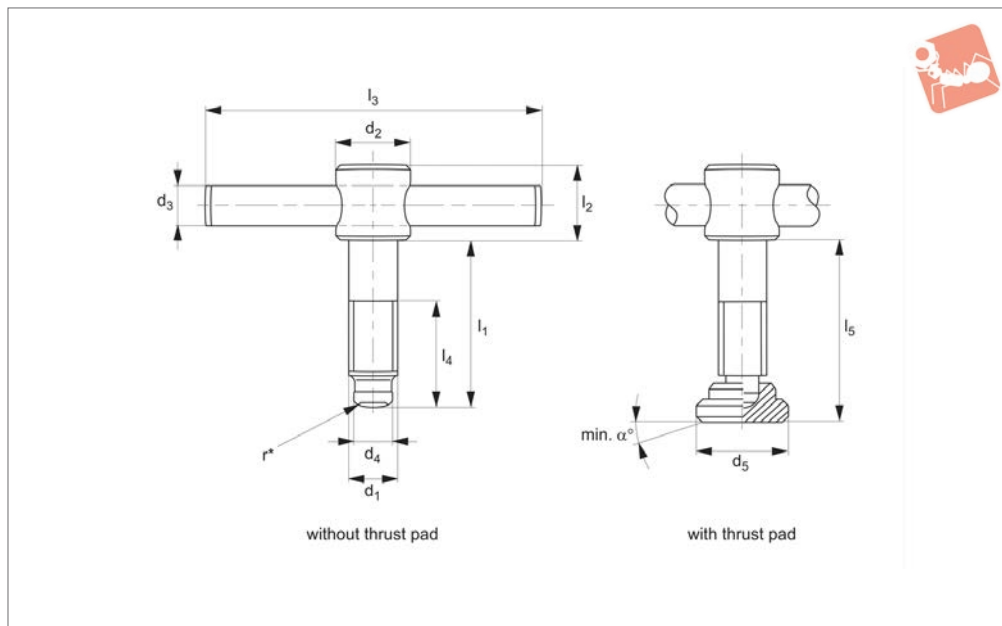

38000

THUMB SCREWS

Material

Free-cutting steel, black. Pressure lug hardened, bar pressed-in.

Technical Notes

To ease assembly minor radius (r^*) added outside of DIN standard.

Order No.	Thrust pad	d ₁	l ₁	d ₂	d ₃	d ₄	d ₅	l ₂	l ₃	l ₄	l ₅	α	Type	Weight with pad g
38000.W0006	W/o Pad	M 6	40	12	5	4.5	-	10	50	30	-	-	w/o Thrust Pad	21
38000.W0007	W/o Pad	M 6	50	12	5	4.5	-	10	50	40	-	-	w/o Thrust Pad	23
38000.W0008	W/o Pad	M 8	50	14	6	6.0	-	12	60	35	-	-	w/o Thrust Pad	39
38000.W0009	W/o Pad	M 8	60	14	6	6.0	-	12	60	45	-	-	w/o Thrust Pad	43
38000.W0010	W/o Pad	M10	60	18	8	8.0	-	14	80	40	-	-	w/o Thrust Pad	82
38000.W0011	W/o Pad	M10	70	18	8	8.0	-	14	80	50	-	-	w/o Thrust Pad	86
38000.W0012	W/o Pad	M12	70	20	10	8.0	-	18	100	50	-	-	w/o Thrust Pad	140
38000.W0013	W/o Pad	M12	80	20	10	8.0	-	18	100	60	-	-	w/o Thrust Pad	149
38000.W0016	W/o Pad	M16	75	24	12	12.0	-	20	120	55	-	-	w/o Thrust Pad	248
38000.W0017	W/o Pad	M16	90	24	12	12.0	-	20	120	70	-	-	w/o Thrust Pad	267
38000.W0018	W/o Pad	M16	110	24	12	12.0	-	20	120	90	-	-	w/o Thrust Pad	294
38000.W0020	W/o Pad	M20	75	30	16	15.5	-	28	140	55	-	-	w/o Thrust Pad	475
38000.W0021	W/o Pad	M20	90	30	16	15.5	-	28	140	70	-	-	w/o Thrust Pad	506
38000.W0022	W/o Pad	M20	110	30	16	15.5	-	28	140	90	-	-	w/o Thrust Pad	548
38000.W0106	With Pad	M 6	40	12	5	4.5	12	10	50	30	42.1	7	With Thrust Pad	24
38000.W0107	With Pad	M 6	50	12	5	4.5	12	10	50	40	52.1	7	With Thrust Pad	28
38000.W0108	With Pad	M 8	50	14	6	6.0	16	12	60	35	53.0	4	With Thrust Pad	49
38000.W0109	With Pad	M 8	60	14	6	6.0	16	12	60	45	63.0	4	With Thrust Pad	54
38000.W0110	With Pad	M10	60	18	8	8.0	20	14	80	40	63.6	2	With Thrust Pad	97
38000.W0111	With Pad	M10	70	18	8	8.0	20	14	80	50	73.6	3	With Thrust Pad	102
38000.W0112	With Pad	M12	70	20	10	8.0	25	18	100	50	74.6	3	With Thrust Pad	173
38000.W0113	With Pad	M12	80	20	10	8.0	25	18	100	60	84.6	3	With Thrust Pad	178
38000.W0116	With Pad	M16	75	24	12	12.0	32	20	120	55	80.4	5	With Thrust Pad	317
38000.W0117	With Pad	M16	90	24	12	12.0	32	20	120	70	95.4	5	With Thrust Pad	342
38000.W0118	With Pad	M16	110	24	12	12.0	32	20	120	90	115.4	5	With Thrust Pad	367
38000.W0120	With Pad	M20	75	30	16	15.5	40	28	140	55	80.5	4	With Thrust Pad	573
38000.W0121	With Pad	M20	90	30	16	15.5	40	28	140	70	95.5	4	With Thrust Pad	603
38000.W0122	With Pad	M20	110	30	16	15.5	40	28	140	90	115.4	4	With Thrust Pad	643



38100

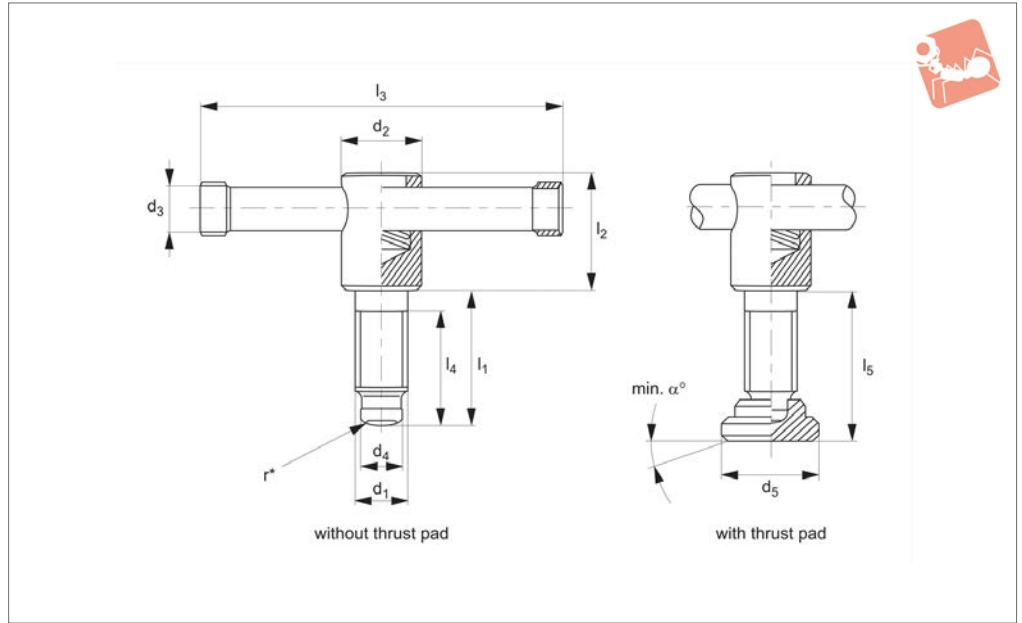

Material

Free-cutting steel, black. Turned, pressure lug hardened, with moveable pin retained

by spring.

outside of DIN standard.

Technical Notes

To ease assembly minor radius (r^*) added

Order No.	Thrust pad	d_1	l_1	d_2	d_3	d_4	d_5	l_2	l_3	l_4	l_5	α	Type	Weight with pad g
38100.W0008	W/o Pad	M 8	40	14	6	6.0	-	25	60	32	-	-	-	41
38100.W0009	W/o Pad	M 8	50	14	6	6.0	-	25	60	42	-	-	-	45
38100.W0010	W/o Pad	M10	40	18	8	8.0	-	32	80	30	-	-	w/o Thrust Pad	91
38100.W0011	W/o Pad	M10	50	18	8	8.0	-	32	80	40	-	-	w/o Thrust Pad	95
38100.W0012	W/o Pad	M12	50	20	10	8.0	-	35	100	40	-	-	w/o Thrust Pad	154
38100.W0013	W/o Pad	M12	60	20	10	8.0	-	35	100	50	-	-	w/o Thrust Pad	161
38100.W0016	W/o Pad	M16	55	24	13	12.0	-	40	120	45	-	-	w/o Thrust Pad	330
38100.W0017	W/o Pad	M16	70	24	13	12.0	-	40	120	60	-	-	w/o Thrust Pad	318
38100.W0018	W/o Pad	M16	90	24	13	12.0	-	40	120	80	-	-	w/o Thrust Pad	345
38100.W0020	W/o Pad	M20	55	30	16	15.5	-	45	140	45	-	-	w/o Thrust Pad	522
38100.W0021	W/o Pad	M20	70	30	16	15.5	-	45	140	60	-	-	w/o Thrust Pad	551
38100.W0022	W/o Pad	M20	90	30	16	15.5	-	45	140	80	-	-	w/o Thrust Pad	593
38100.W0108	With Pad	M 8	40	14	6	6.0	16	25	60	32	43.0	3	-	50
38100.W0109	With Pad	M 8	50	14	6	6.0	16	25	60	42	53.0	3	-	54
38100.W0110	With Pad	M10	40	18	8	8.0	20	32	80	30	43.6	3	With Thrust Pad	110
38100.W0111	With Pad	M10	50	18	8	8.0	20	32	80	40	53.6	3	With Thrust Pad	114
38100.W0112	With Pad	M12	50	20	10	8.0	25	35	100	40	52.6	3	With Thrust Pad	193
38100.W0113	With Pad	M12	60	20	10	8.0	25	35	100	50	64.6	3	With Thrust Pad	198
38100.W0116	With Pad	M16	55	24	13	12.0	32	40	120	45	60.4	5	With Thrust Pad	357
38100.W0117	With Pad	M16	70	24	13	12.0	32	40	120	60	75.4	5	With Thrust Pad	377
38100.W0118	With Pad	M16	90	24	13	12.0	32	40	120	80	95.4	5	With Thrust Pad	402
38100.W0120	With Pad	M20	55	30	16	15.5	40	45	140	45	60.5	4	With Thrust Pad	623
38100.W0121	With Pad	M20	70	30	16	15.5	40	45	140	60	75.5	4	With Thrust Pad	653
38100.W0122	With Pad	M20	90	30	16	15.5	40	45	140	80	95.5	4	With Thrust Pad	693



Tommy Nuts with fixed bar - DIN 6305



Thumb Screws

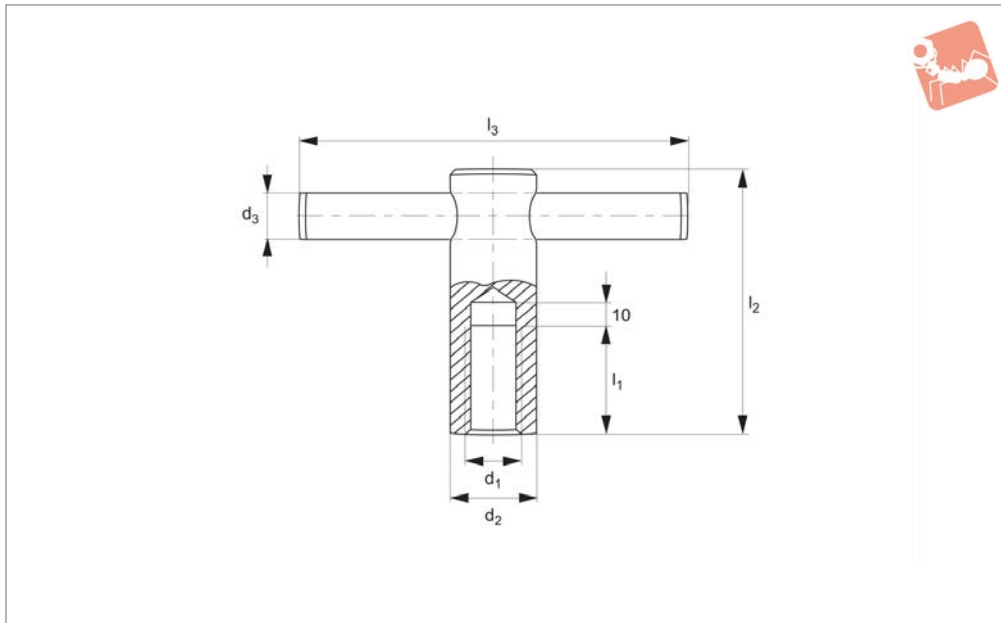

38200

THUMB SCREWS

Material

Free-cutting steel, blackened. Moveable bar retained by spring.

Technical Notes

* - DIN standards do not include these dimensions.

Order No.	d ₁	l ₁	d ₂	d ₃	l ₂	l ₃	Weight g
38200.W0508	M 8	16	16	6	50	60	79
38200.W0510	M10	20	18	8	60	80	127
38200.W0512	M12	25	20	10	70	100	192
38200.W0516	M16	35	24	12	85	120	318
38200.W0520	M20	40	30	16	95	140	590



38300

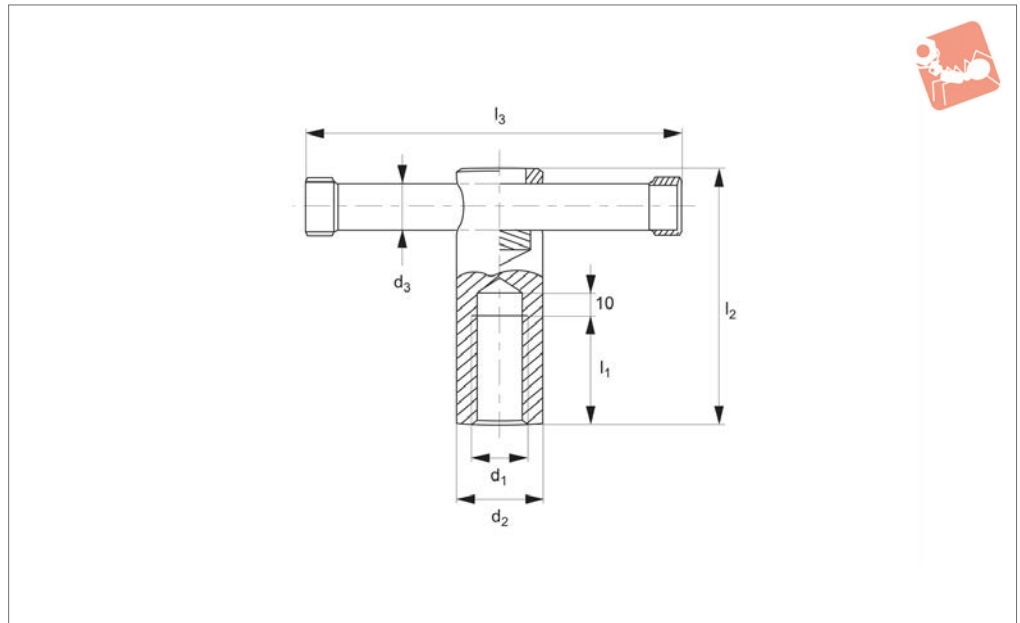

Material

Free-cutting steel, blackened. Moveable bar retained by spring.

Technical Notes

* - DIN standards do not include these dimensions.

Order No.	d ₁	l ₁	d ₂	d ₃	l ₂	l ₃	Weight g
38300.W0708	M 8	16	16	6	50	60	69
38300.W0710	M10	20	18	8	60	80	112
38300.W0712	M12	25	20	10	70	100	179
38300.W0716	M16	35	24	13	85	120	327
38300.W0720	M20	40	30	16	95	140	581

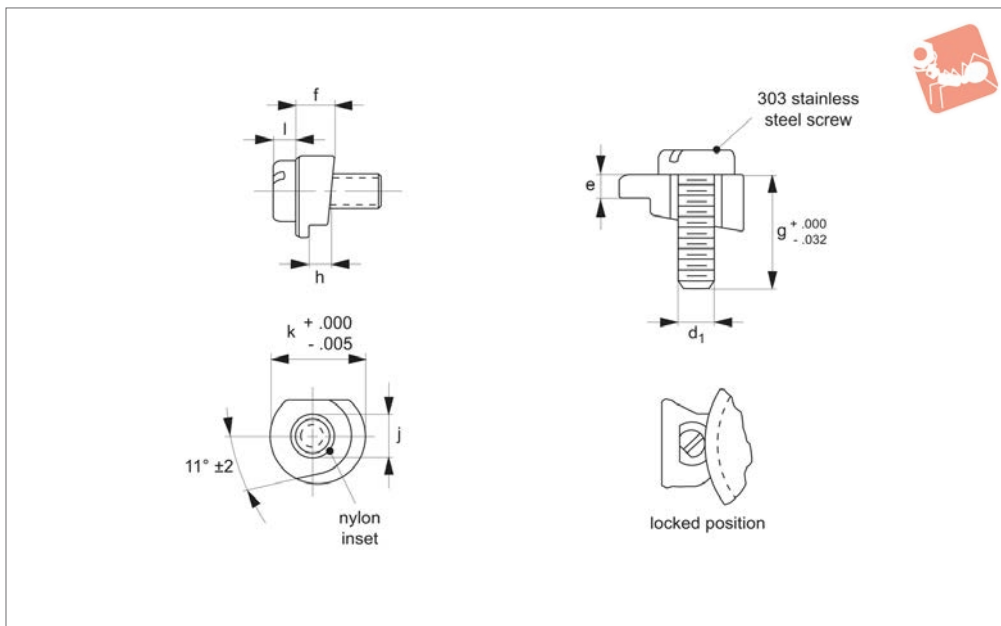

36560

CLAMP CLEATS

Material

Stainless steel (A4, AISI316, DIN 1.4401), with nylon insert.

Supplied with A2 (AISI303) stainless steel screw (screws not supplied with P1092.019, .020, or .026).

Technical Notes

Quick release, faster clamping and self-locking.

Tips

Bolt circle: use the larger of the following two bolt circles:

add 6,86 to max. flange diameter or add 10,16 to max. groove base diameter.

Order No.	h_1 $\pm 6,08$	d_1	h_2 $\pm 0,08$	h_3	h_4	l_1 $+0 -0.8$	w_1	w_2 $+0 -0.15$
36560.W0006	0.79	M3	1.02	1.80	1.73	8.0	9.90	3.18
36560.W0007	1.57	M3	1.02	2.59	1.73	8.0	9.90	3.18
36560.W0008	1.58	M3	1.27	2.84	1.73	10.0	9.90	3.18
36560.W0009	1.57	M3	1.60	3.18	1.73	10.0	9.90	3.18
36560.W0010	1.98	M3	1.60	3.58	1.73	10.0	9.90	3.18
36560.W0011	2.36	M3	1.02	3.38	1.73	10.0	9.90	3.18
36560.W0012	2.36	M3	1.27	3.63	1.73	10.0	9.90	3.18
36560.W0013	2.36	M3	1.60	3.96	1.73	10.0	9.90	3.18
36560.W0014	3.18	M3	1.27	4.45	1.73	10.0	9.90	3.18
36560.W0015	3.96	M3	1.02	4.98	1.73	10.0	9.90	3.18
36560.W0016	5.72	M3	1.60	7.32	1.73	12.0	9.90	3.18
36560.W0017	6.35	M3	1.60	7.92	1.73	16.0	9.90	3.18

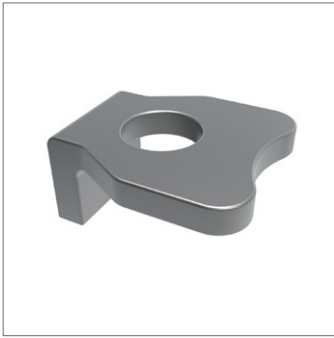

36580

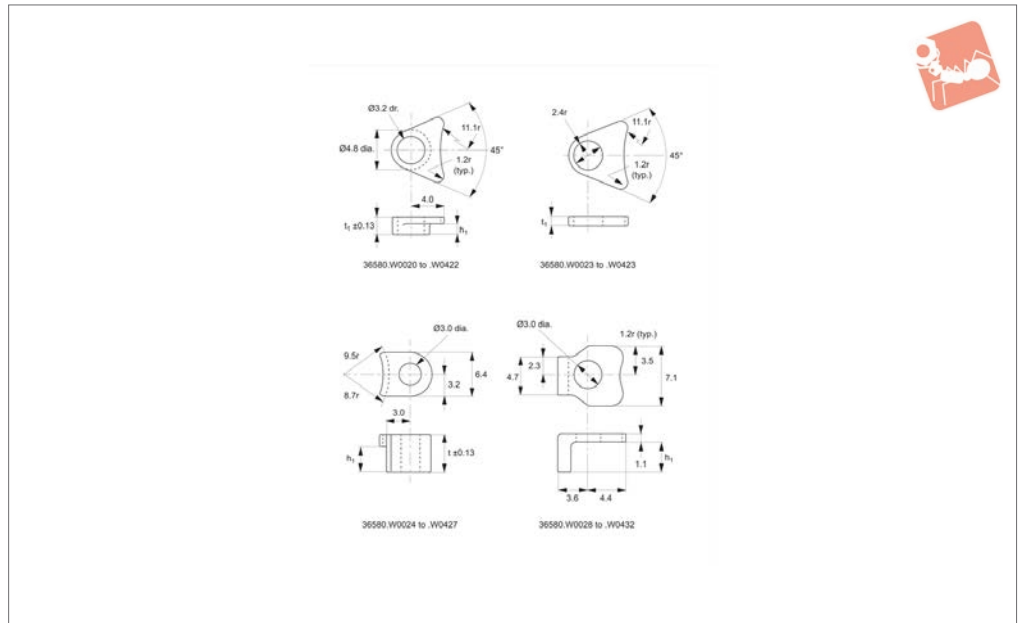

Material

Stainless steel DIN 1,4305 (AISI 303) or aluminium 2024.

Technical Notes

Quick release, faster clamping and self-

locking.

10,16 to max. groove base diameter.

Tips

Bolt circle: use the larger of the following two bolt circles:
add 6,86 to max. flange diameter OR add

Order No.	Type	Material	h_1	t_1
36580.W0020	A	Stainless	1.2	2.36
36580.W0021	A	Stainless	1.2	2.36
36580.W0022	A	Stainless	2.8	3.96
36580.W0023	B	Stainless	2.8	3.96
36580.W0024	C	Stainless	5.3	6.91
36580.W0025	C	Stainless	5.3	6.91
36580.W0026	C	Stainless	-	1.02
36580.W0027	C	Stainless	-	1.02
36580.W0028	D	Stainless	0.5	1.65
36580.W0029	D	Stainless	0.5	1.65
36580.W0030	D	Stainless	1.3	2.41
36580.W0031	D	Stainless	1.3	2.41
36580.W0032	D	Stainless	2.9	4.06
36580.W0420	A	Aluminium	2.9	4.06
36580.W0421	A	Aluminium	4.5	5.59
36580.W0422	A	Aluminium	4.5	5.59
36580.W0423	B	Aluminium	Flat	-
36580.W0424	C	Aluminium	1.2	-
36580.W0425	C	Aluminium	2.0	-
36580.W0426	C	Aluminium	2.8	-
36580.W0427	C	Aluminium	3.6	-

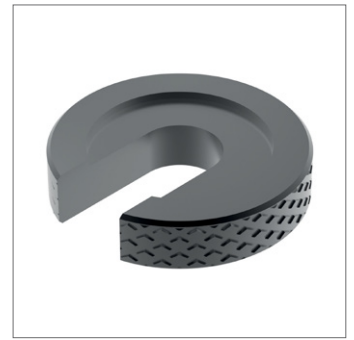
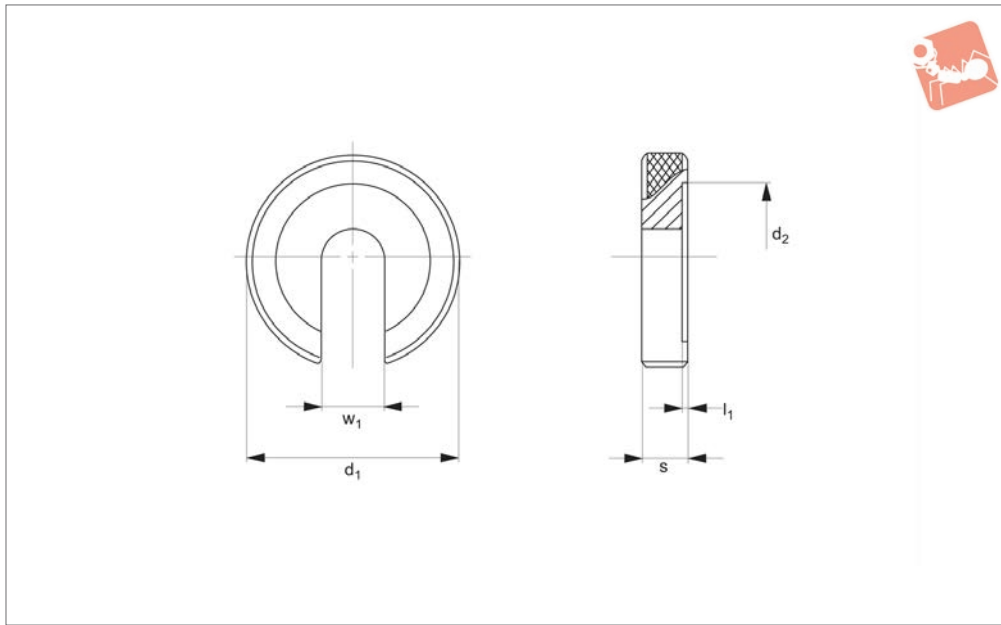

36600

CLAMP CLEATS

Material

Heat-treated steel, blackened, tempered.

Technical Notes

Produced to DIN 6372.

Order No.	d_1	w_1	l_1	d_2	s	Weight g
36600.W0012	40	13	1.8	30	9	57
36600.W0016	56	17	1.8	37	12	164



SHOULDER SCREWS



36642.A2

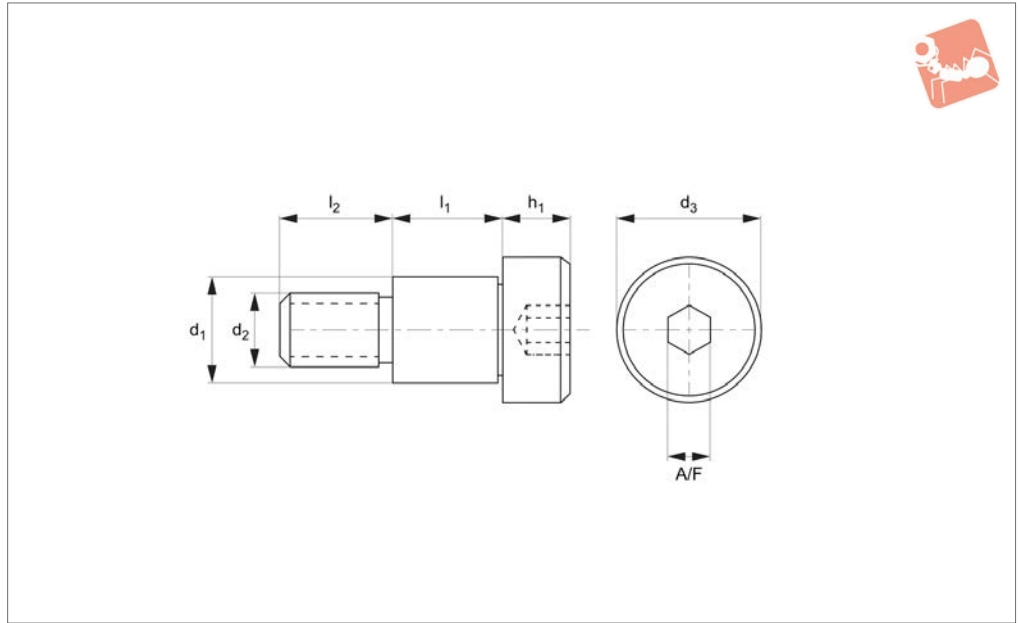

Material

Stainless steel (AISI 303, 1.4305). Tensile strength 550 N/mm². Proof stress min. 190 N/mm², austenitic stainless steel.

Technical Notes

303 series stainless steel provides good resistance to corrosion. It is mildly magnetic.

For torx drive versions please see P0145.

Special lengths and diameters produced to drawings.

Order No.	d ₁ +0 -0.025	l ₁ +0.05 -0.0	d ₂	d ₃	l ₂	h ₁	A/F
36642.W0404-A2	4	4	M 3	6	4	3	2
36642.W0405-A2	4	5	M 3	6	4	3	2
36642.W0406-A2	4	6	M 3	6	4	3	2
36642.W0408-A2	4	8	M 3	6	4	3	2
36642.W0410-A2	4	10	M 3	6	4	3	2
36642.W0504-A2	5	4	M 4	8	5	4	2.5
36642.W0505-A2	5	5	M 4	8	5	4	2.5
36642.W0506-A2	5	6	M 4	8	5	4	2.5
36642.W0508-A2	5	8	M 4	8	5	4	2.5
36642.W0510-A2	5	10	M 4	8	5	4	2.5
36642.W0512-A2	5	12	M 4	8	5	4	2.5
36642.W0514-A2	5	14	M 4	8	5	4	2.5
36642.W0516-A2	5	16	M 4	8	5	4	2.5
36642.W0520-A2	5	20	M 4	8	5	4	2.5
36642.W0525-A2	5	25	M 4	8	5	4	2.5
36642.W0530-A2	5	30	M 4	8	5	4	2.5
36642.W0604-A2	6	4	M 5	10	6	5	3
36642.W0605-A2	6	5	M 5	10	6	5	3
36642.W0606-A2	6	6	M 5	10	6	5	3
36642.W0608-A2	6	8	M 5	10	6	5	3
36642.W0610-A2	6	10	M 5	10	6	5	3
36642.W0612-A2	6	12	M 5	10	6	5	3
36642.W0614-A2	6	14	M 5	10	6	5	3
36642.W0616-A2	6	16	M 5	10	6	5	3
36642.W0620-A2	6	20	M 5	10	6	5	3
36642.W0625-A2	6	25	M 5	10	6	5	3
36642.W0630-A2	6	30	M 5	10	6	5	3
36642.W0640-A2	6	40	M 5	10	6	5	3
36642.W0650-A2	6	50	M 5	10	6	5	3
36642.W0660-A2	6	60	M 5	10	6	5	3
36642.W0806-A2	8	6	M 6	12	11	6	4
36642.W0808-A2	8	8	M 6	12	11	6	4
36642.W0810-A2	8	10	M 6	12	11	6	4
36642.W0812-A2	8	12	M 6	12	11	6	4



Shoulder Screws - Cap Head

hex drive - 303 stainless

Shoulder Screws



Order No.	d ₁ +0 -0.025	l ₁ +0.05 -0.0	d ₂	d ₃	l ₂	h ₁	A/F
36642.W0814-A2	8	14	M 6	12	11	6	4
36642.W0816-A2	8	16	M 6	12	11	6	4
36642.W0820-A2	8	20	M 6	12	11	6	4
36642.W0825-A2	8	25	M 6	12	11	6	4
36642.W0830-A2	8	30	M 6	12	11	6	4
36642.W0840-A2	8	40	M 6	12	11	6	4
36642.W0850-A2	8	50	M 6	12	11	6	4
36642.W0860-A2	8	60	M 6	12	11	6	4
36642.W0870-A2	8	70	M 6	12	11	6	4
36642.W0880-A2	8	80	M 6	12	11	6	4
36642.W1010-A2	10	10	M 6	14	11	7	5
36642.W1108-A2	10	8	M 8	14	12	7	5
36642.W1110-A2	10	10	M 8	14	12	7	5
36642.W1112-A2	10	12	M 8	14	12	7	5
36642.W1116-A2	10	16	M 8	14	12	7	5
36642.W1120-A2	10	20	M 8	14	12	7	5
36642.W1125-A2	10	25	M 8	14	12	7	5
36642.W1130-A2	10	30	M 8	14	12	7	5
36642.W1140-A2	10	40	M 8	14	12	7	5
36642.W1150-A2	10	50	M 8	14	12	7	5
36642.W1160-A2	10	60	M 8	14	12	7	5
36642.W1170-A2	10	70	M 8	14	12	7	5
36642.W1180-A2	10	80	M 8	14	12	7	5
36642.W1190-A2	10	90	M 8	14	12	7	5
36642.W1199-A2	10	100	M 8	14	12	7	5
36642.W1212-A2	12	12	M10	20	16	8	6
36642.W1216-A2	12	16	M10	20	16	8	6
36642.W1220-A2	12	20	M10	20	16	8	6
36642.W1225-A2	12	25	M10	20	16	8	6
36642.W1230-A2	12	30	M10	20	16	8	6
36642.W1240-A2	12	40	M10	20	16	8	6
36642.W1250-A2	12	50	M10	20	16	8	6
36642.W1260-A2	12	60	M10	20	16	8	6
36642.W1290-A2	12	90	M10	20	16	8	6
36642.W1625-A2	16	25	M12	24	18	11	8
36642.W1630-A2	16	30	M12	24	18	11	8
36642.W1640-A2	16	40	M12	24	18	11	8
36642.W1650-A2	16	50	M12	24	18	11	8
36642.W1660-A2	16	60	M12	24	18	11	8
36642.W1670-A2	16	70	M12	24	18	11	8
36642.W1699-A2	16	100	M12	24	18	11	8
36642.W2030-A2	20	30	M16	30	22	14	10
36642.W2040-A2	20	40	M16	30	22	14	10
36642.W2050-A2	20	50	M16	30	22	14	10
36642.W2060-A2	20	60	M16	30	22	14	10

SHOULDER SCREWS



SHOULDER SCREWS



36644.A4

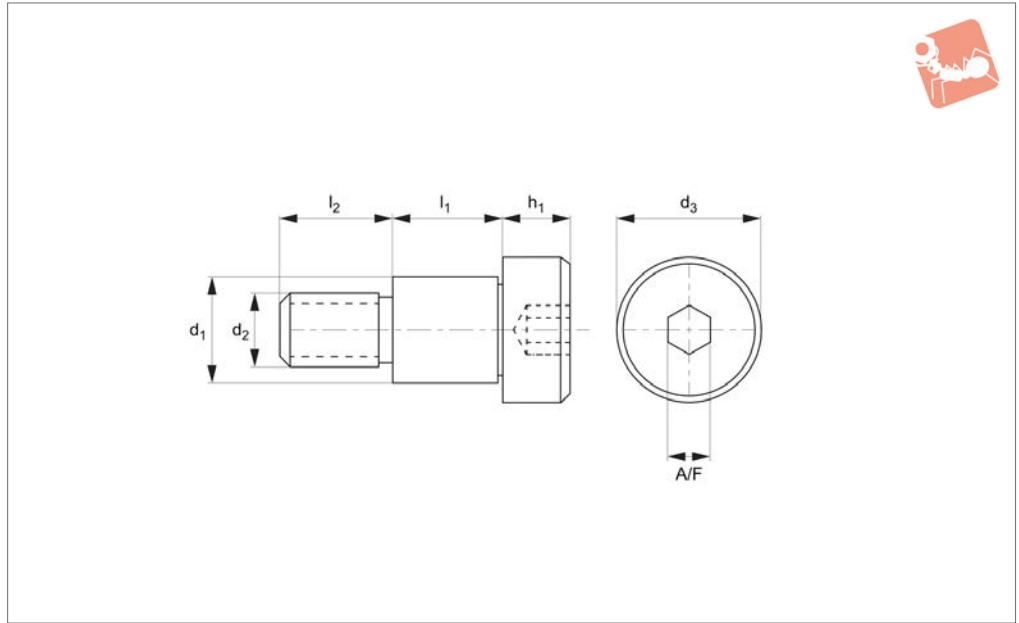

Material

Stainless steel (AISI 316, 1.440).
Tensile strength 480 N/mm².
Proof stress min. 200 N/mm², austenitic stainless steel.

Technical Notes

Highly resistant to corrosion (including

from salt water).

These 316 series stainless steel shoulder bolts are considerably more expensive than our standard 303 grade stainless shoulder bolts (P0130+).

Shim washers can be used to reduce shoulder length if required. It is non-

magnetic.

Can also be manufactured (for a batch size) in aluminium, monel & titanium.

Order No.	d ₁ +0 -0.025	l ₁ +0.05 -0.0	d ₂	d ₃	l ₂	h ₁	A/F
36644.W0404-A4	4	4	M 3	6	4	3.0	2
36644.W0405-A4	4	5	M 3	6	4	3.0	2
36644.W0406-A4	4	6	M 3	6	4	3.0	2
36644.W0408-A4	4	8	M 3	6	4	3.0	2
36644.W0410-A4	4	10	M 3	6	4	3.0	2
36644.W0510-A4	5	10	M 4	8	5	4.0	2.5
36644.W0512-A4	5	12	M 4	8	5	4.0	2.5
36644.W0516-A4	5	16	M 4	8	5	4.0	2.5
36644.W0520-A4	5	20	M 4	8	5	4.0	2.5
36644.W0525-A4	5	25	M 4	8	5	4.0	2.5
36644.W0530-A4	5	30	M 4	8	5	4.0	2.5
36644.W0610-A4	6	10	M 5	10	6	5.0	3
36644.W0612-A4	6	12	M 5	10	6	5.0	3
36644.W0616-A4	6	16	M 5	10	6	5.0	3
36644.W0620-A4	6	20	M 5	10	6	5.0	3
36644.W0625-A4	6	25	M 5	10	6	5.0	3
36644.W0630-A4	6	30	M 5	10	6	5.0	3
36644.W0640-A4	6	40	M 5	10	6	5.0	3
36644.W0650-A4	6	50	M 5	10	6	5.0	3
36644.W0812-A4	8	12	M 6	12	11	6.0	4
36644.W0816-A4	8	16	M 6	12	11	6.0	4
36644.W0820-A4	8	20	M 6	12	11	6.0	4
36644.W0825-A4	8	25	M 6	12	11	6.0	4
36644.W0830-A4	8	30	M 6	12	11	6.0	4
36644.W0840-A4	8	40	M 6	12	11	6.0	4
36644.W0850-A4	8	50	M 6	12	11	6.0	4
36644.W1016-A4	10	16	M 8	14	12	7.0	5
36644.W1020-A4	10	20	M 8	14	12	7.0	5
36644.W1025-A4	10	25	M 8	14	12	7.0	5
36644.W1030-A4	10	30	M 8	14	12	7.0	5



Shoulder Screws - Cap Head

hex drive - 316 stainless

Shoulder Screws



Order No.	d_1 +0 -0.025	l_1 +0.05 -0.0	d_2	d_3	l_2	h_1	A/F
36644.W1040-A4	10	40	M 8	14	12	7.0	5
36644.W1050-A4	10	50	M 8	14	12	7.0	5
36644.W1060-A4	10	60	M 8	14	12	7.0	5
36644.W1070-A4	10	70	M 8	14	12	7.0	5
36644.W1216-A4	12	16	M10	20	16	8.0	6
36644.W1220-A4	12	20	M10	20	16	8.0	6
36644.W1225-A4	12	25	M10	20	16	8.0	6
36644.W1230-A4	12	30	M10	20	16	8.0	6
36644.W1240-A4	12	40	M10	20	16	8.0	6
36644.W1250-A4	12	50	M10	20	16	8.0	6
36644.W1260-A4	12	60	M10	20	16	8.0	6
36644.W1270-A4	12	70	M10	20	16	8.0	6

SHOULDER SCREWS



SHOULDER SCREWS



36650

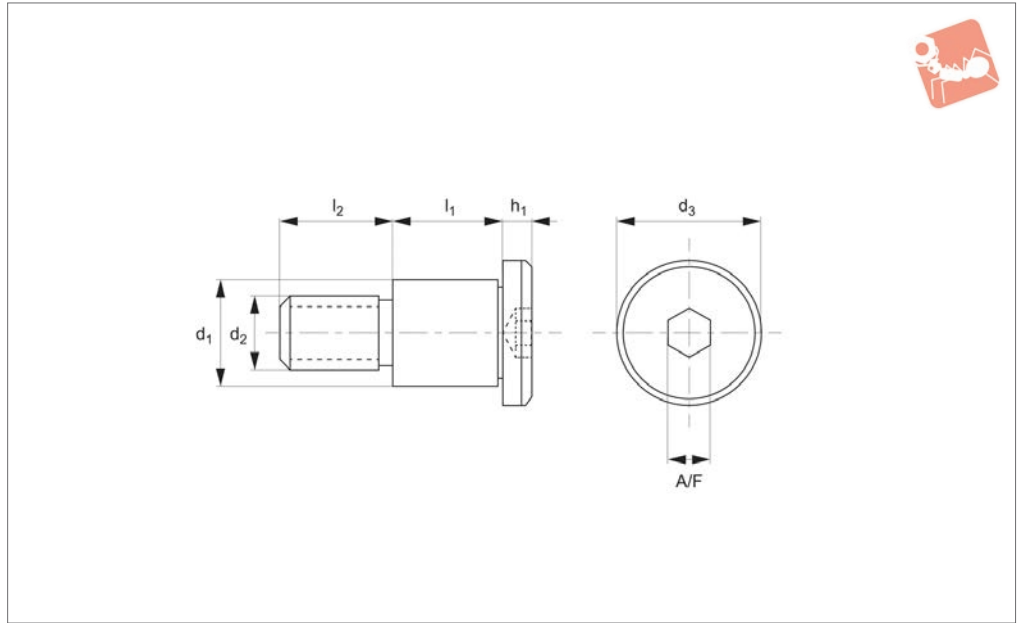

Material

Stainless steel (AISI 303, 1.4305). Tensile strength 550 N/mm². Proof stress min. 190 N/mm², austenitic stainless steel.

Technical Notes

These very low profile socket shoulder

screws have a head height approximately 1/3 that of normal shoulder screws (P0130).

303 Series stainless is suitable for pharmaceutical and other applications. Stainless steel suitable for marine and other appli-

cations.

Order No.	d_1 +0 -0.025	l_1 +0.05 -0.0	d_2	d_3	l_2	h_1	A/F
36650.W0401	4	4	M 3	6	4	1.3	2
36650.W0402	4	5	M 3	6	4	1.3	2
36650.W0403	4	6	M 3	6	4	1.3	2
36650.W0404	4	8	M 3	6	4	1.3	2
36650.W0405	4	10	M 3	6	4	1.3	2
36650.W0406	5	4	M 4	9	5	1.3	2.5
36650.W0407	5	5	M 4	9	5	1.3	2.5
36650.W0408	5	6	M 4	9	5	1.3	2.5
36650.W0409	5	8	M 4	9	5	1.3	2.5
36650.W0410	5	10	M 4	9	5	1.3	2.5
36650.W0411	5	12	M 4	9	5	1.3	2.5
36650.W0413	5	16	M 4	9	5	1.3	2.5
36650.W0414	5	20	M 4	9	5	1.3	2.5
36650.W0417	6	4	M 5	10	6	1.7	3
36650.W0418	6	5	M 5	10	6	1.7	3
36650.W0419	6	6	M 5	10	6	1.7	3
36650.W0420	6	8	M 5	10	6	1.7	3
36650.W0421	6	10	M 5	10	6	1.7	3
36650.W0422	6	12	M 5	10	6	1.7	3
36650.W0424	6	16	M 5	10	6	1.7	3
36650.W0425	6	20	M 5	10	6	1.7	3
36650.W0428	8	6	M 6	13	11	2.0	4
36650.W0429	8	8	M 6	13	11	2.0	4
36650.W0430	8	10	M 6	13	11	2.0	4
36650.W0431	8	12	M 6	13	11	2.0	4
36650.W0432	8	16	M 6	13	11	2.0	4
36650.W0433	8	20	M 6	13	11	2.0	4



Shoulder Screws - Slot Head slot drive - 416 stainless

Shoulder Screws

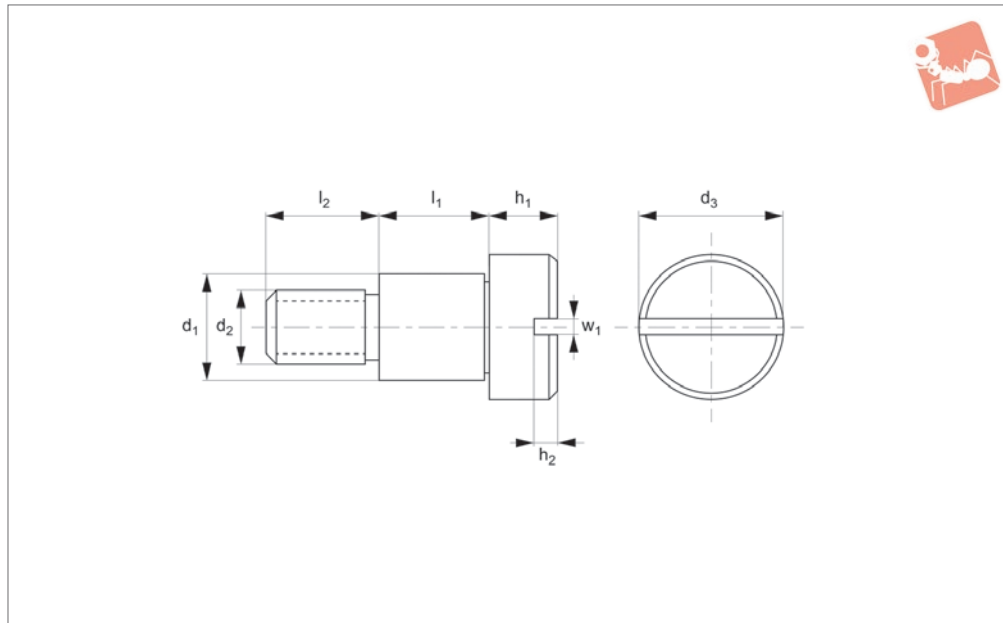

36660

SHOULDER SCREWS

Material

Stainless steel (AISI 416, 1.4005). Tensile strength 650 N/mm². Proof stress min. 450 N/mm², martensitic stainless steel.

Technical Notes

Stainless steel 416 is a harder, stronger

grade of stainless steel than the 303 stainless alternatives.

They are magnetic and slightly less resistant to corrosion than the 303 alternative (see P0130 or P0132).

For corrosion resistance it is suited to dry

atmosphere, fresh water and mild alkalis and acids.

Special lengths and diameters produced to drawings.

Order No.	d ₁ +0 -0.025	l ₁ +0.05 -0.0	d ₂	d ₃	l ₂	h ₁	h ₂	w ₁
36660.W0001	4	4	M 3	6	4	3	0.3	0.4
36660.W0002	4	5	M 3	6	4	3	0.3	0.4
36660.W0003	4	6	M 3	6	4	3	0.3	0.4
36660.W0004	4	8	M 3	6	4	3	0.3	0.4
36660.W0005	4	10	M 3	6	4	3	0.3	0.4
36660.W0006	5	4	M 4	8	5	4	0.9	0.8
36660.W0007	5	5	M 4	8	5	4	0.9	0.8
36660.W0008	5	6	M 4	8	5	4	0.9	0.8
36660.W0009	5	8	M 4	8	5	4	0.9	0.8
36660.W0010	5	10	M 4	8	5	4	0.9	0.8
36660.W0011	5	12	M 4	8	5	4	0.9	0.8
36660.W0012	5	14	M 4	8	5	4	0.9	0.8
36660.W0013	5	16	M 4	8	5	4	0.9	0.8
36660.W0014	5	20	M 4	8	5	4	0.9	0.8
36660.W0016	5	30	M 4	8	5	4	0.9	0.8
36660.W0017	6	4	M 5	10	6	5	1.2	1.0
36660.W0018	6	5	M 5	10	6	5	1.2	1.0
36660.W0019	6	6	M 5	10	6	5	1.2	1.0
36660.W0020	6	8	M 5	10	6	5	1.2	1.0
36660.W0021	6	10	M 5	10	6	5	1.2	1.0
36660.W0023	6	14	M 5	10	6	5	1.2	1.0
36660.W0024	6	16	M 5	10	6	5	1.2	1.0
36660.W0025	6	20	M 5	10	6	5	1.2	1.0
36660.W0026	6	25	M 5	10	6	5	1.2	1.0
36660.W0027	6	30	M 5	10	6	5	1.2	1.0
36660.W0028	8	6	M 6	12	11	6	1.3	1.2
36660.W0029	8	8	M 6	12	11	6	1.3	1.2
36660.W0032	8	16	M 6	12	11	6	1.3	1.2
36660.W0034	10	8	M 6	12	11	6	1.5	1.6
36660.W0036	10	12	M 6	12	11	6	1.5	1.6
36660.W0037	10	16	M 6	12	11	6	1.5	1.6



Order No.	d_1 +0 -0.025	l_1 +0.05 -0.0	d_2	d_3	l_2	h_1	h_2	w_1
36660.W0042	12	12	M10	20	16	8	2.4	2.5
36660.W0043	12	16	M10	20	16	8	2.4	2.5
36660.W0045	12	26	M10	20	16	8	2.4	2.5



Shoulder Screw - Cap Head

slot drive - 303 stainless

Shoulder Screws

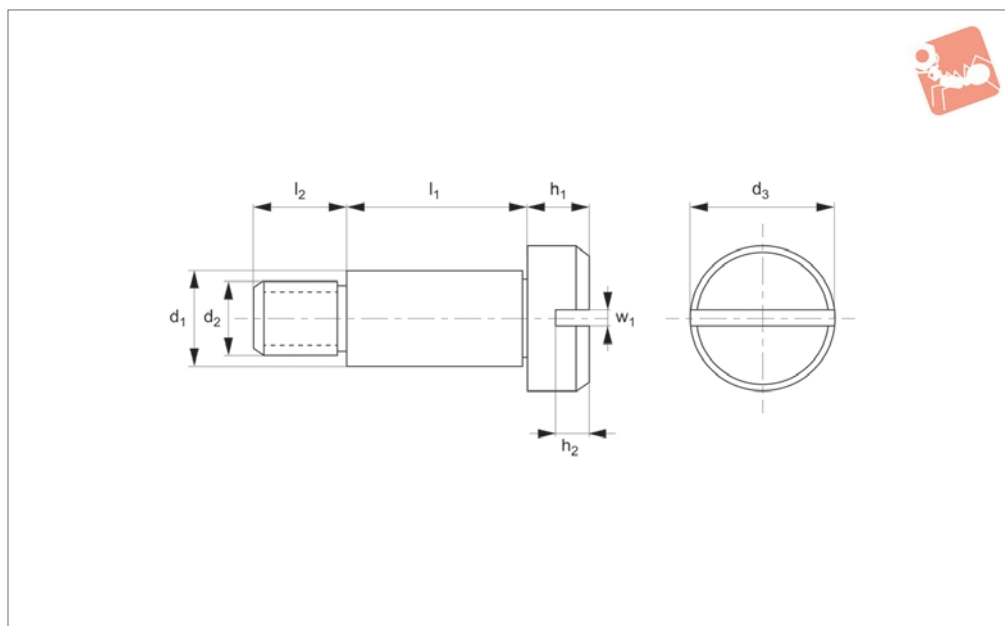

36662.A2

SHOULDER SCREWS

Material

Stainless steel (AISI 303, 1.4305). Tensile strength 550 N/mm². Proof stress min. 190 N/mm², austenitic stainless steel.

resistance to corrosion. It is mildly magnetic. screws are less expensive than the 416 steel grade (see part no. 36660), which are harder but less resistant to corrosion.

shoulder screws see part no. . . Special lengths and diameters produced to drawings.

Technical Notes

303 series stainless steel provides good

For Ø16 (and above) stainless steel

Order No.	d ₁ +0 -0.025	l ₁ +0.05 -0.0	d ₂	d ₃	l ₂	h ₁	h ₂	w ₁
36662.W0404-A2	4	4	M 3	6	4	3	0.9	0.8
36662.W0405-A2	4	5	M 3	6	4	3	0.9	0.8
36662.W0406-A2	4	6	M 3	6	4	3	0.9	0.8
36662.W0408-A2	4	8	M 3	6	4	3	0.9	0.8
36662.W0410-A2	4	10	M 3	6	4	3	0.9	0.8
36662.W0504-A2	5	4	M 4	8	5	4	1.2	1.0
36662.W0505-A2	5	5	M 4	8	5	4	1.2	1.0
36662.W0506-A2	5	6	M 4	8	5	4	1.2	1.0
36662.W0508-A2	5	8	M 4	8	5	4	1.2	1.0
36662.W0510-A2	5	10	M 4	8	5	4	1.2	1.0
36662.W0512-A2	5	12	M 4	8	5	4	1.2	1.0
36662.W0514-A2	5	14	M 4	8	5	4	1.2	1.0
36662.W0516-A2	5	16	M 4	8	5	4	1.2	1.0
36662.W0520-A2	5	20	M 4	8	5	4	1.2	1.0
36662.W0525-A2	5	25	M 4	8	5	4	1.2	1.0
36662.W0530-A2	5	30	M 4	8	5	4	1.2	1.0
36662.W0604-A2	6	4	M 5	10	6	5	1.3	1.2
36662.W0605-A2	6	5	M 5	10	6	5	1.3	1.2
36662.W0606-A2	6	6	M 5	10	6	5	1.3	1.2
36662.W0608-A2	6	8	M 5	10	6	5	1.3	1.2
36662.W0610-A2	6	10	M 5	10	6	5	1.3	1.2
36662.W0612-A2	6	12	M 5	10	6	5	1.3	1.2
36662.W0614-A2	6	14	M 5	10	6	5	1.3	1.2
36662.W0616-A2	6	16	M 5	10	6	5	1.3	1.2
36662.W0620-A2	6	20	M 5	10	6	5	1.3	1.2
36662.W0625-A2	6	25	M 5	10	6	5	1.3	1.2
36662.W0630-A2	6	30	M 5	10	6	5	1.3	1.2
36662.W0806-A2	8	6	M 6	12	11	6	1.5	1.6
36662.W0808-A2	8	8	M 6	12	11	6	1.5	1.6
36662.W0812-A2	8	12	M 6	12	11	6	1.5	1.6
36662.W0816-A2	8	16	M 6	12	11	6	1.5	1.6



Order No.	d_1 +0 -0.025	l_1 +0.05 -0.0	d_2	d_3	l_2	h_1	h_2	w_1
36662.W1008-A2	10	8	M 6	14	11	6	1.5	1.6
36662.W1012-A2	10	12	M 6	14	11	6	1.5	1.6
36662.W1108-A2	10	8	M 8	14	12	7	1.9	2.0
36662.W1112-A2	10	12	M 8	14	12	7	1.9	2.0
36662.W1116-A2	10	16	M 8	14	12	7	1.9	2.0
36662.W1212-A2	12	12	M10	20	16	8	2.4	2.5
36662.W1225-A2	12	16	M10	20	16	8	2.4	2.5

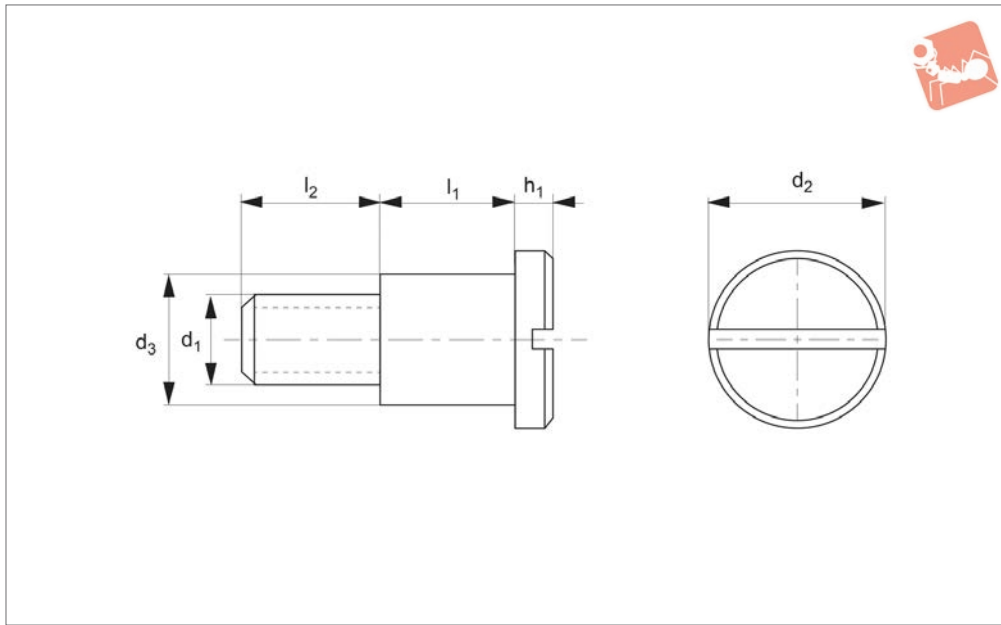

36700

SHOULDER SCREWS

Material

Steel, strength class 5.8, blackened. Case hardened to 0,2 - 0,4mm depth.

36620.

$l_1 = 16 (+0,20/0,10)$.

Technical Notes

Suitable for use with captive C washers no.

Tips

Dimension tolerances:

$l_1 = 10 (+0,15/+0,07)$,

$l_1 = 12 (+0,20/+0,10)$,

Order No.	d_1	l_1	d_2	d_3 tol. h9	l_2	h_1	Weight g
36700.W0006	M_6	10	13	8	9.0	3.1	9
36700.W0008	M_8	12	16	10	11.0	3.8	17
36700.W0009	M_8	16	16	10	11.0	3.8	20



36681

MADE IN BRITAIN

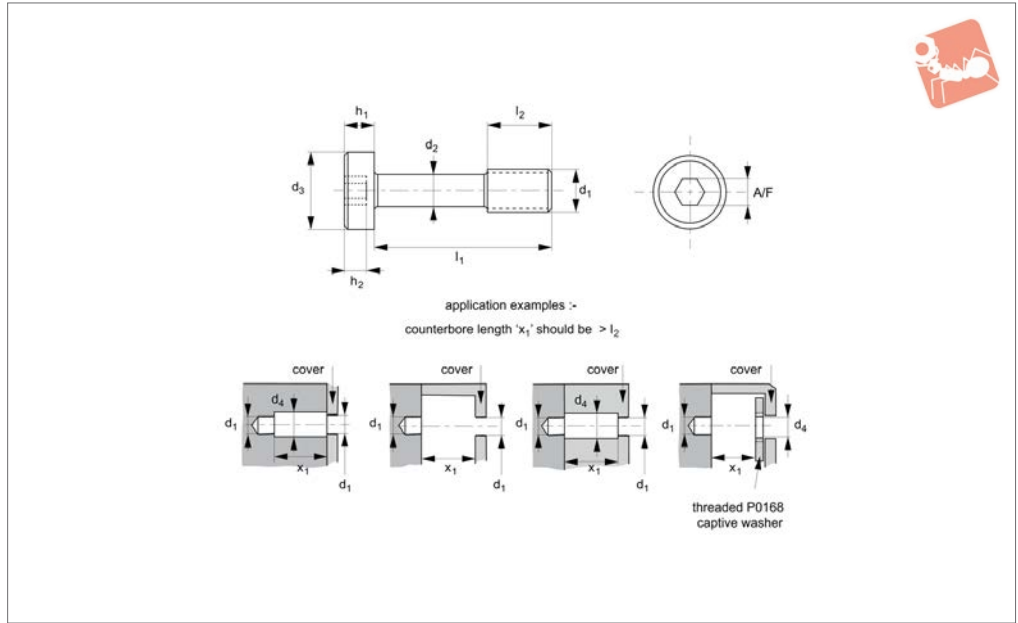

CAPTIVE SCREWS

Material

Stainless steel (AISI 303, 1.4305). Tensile strength 550 N/mm². Proof stress min. 190 N/mm², austenitic stainless steel. Also available on request in steel (anodised, black oxide or zinc plated), stainless steel (AISI 316, 1.440), brass, aluminium etc.

Technical Notes

Used to comply with the Machinery Direc-

tive 2006/42/EC. Generally to ISO 1207. Often used with our captive washers (36691) or retaining flanges (36692 - for sheet metal applications). The use of our captive washers should be considered when fitted in panels with unthreaded holes.

Important Notes

Please note that these screws have a

reduced diameter shank and should not be tightened to the recommended torque for an equivalent machine screw of size d₁.

Order No.	d ₁	l ₁ ±0.25	d ₂ ±0.12	d ₃	d ₄ min.	h ₁	h ₂	l ₂ ±0.25	A/F
36681.W2010	M 2	10	1.2	3.8	2.5	1.3	0.85	3.0	1.3
36681.W2012	M 2	12	1.2	3.8	2.5	1.3	0.85	3.0	1.3
36681.W2016	M 2	16	1.2	3.8	2.5	1.3	0.85	3.0	1.3
36681.W2020	M 2	20	1.2	3.8	2.5	1.3	0.85	3.0	1.3
36681.W2510	M 2,5	10	1.7	4.5	2.8	1.6	1.00	3.7	1.5
36681.W2516	M 2,5	16	1.7	4.5	2.8	1.6	1.00	3.7	1.5
36681.W2520	M 2,5	20	1.7	4.5	2.8	1.6	1.00	3.7	1.5
36681.W2525	M 2,5	25	1.7	4.5	2.8	1.6	1.00	3.7	1.5
36681.W2530	M 2,5	30	1.7	4.5	2.8	1.6	1.00	3.7	1.5
36681.W3010	M 3	10	2.0	5.5	3.5	2.0	1.30	4.5	2
36681.W3011	M 3	11	2.0	5.5	3.5	2.0	1.30	4.5	2
36681.W3013	M 3	13	2.0	5.5	3.5	2.0	1.30	4.5	2
36681.W3016	M 3	16	2.0	5.5	3.5	2.0	1.30	4.5	2
36681.W3018	M 3	18	2.0	5.5	3.5	2.0	1.30	4.5	2
36681.W3020	M 3	20	2.0	5.5	3.5	2.0	1.30	4.5	2
36681.W3025	M 3	25	2.0	5.5	3.5	2.0	1.30	4.5	2
36681.W3030	M 3	30	2.0	5.5	3.5	2.0	1.30	4.5	2
36681.W3040	M 3	40	2.0	5.5	3.5	2.0	1.30	4.5	2
36681.W3510	M 3,5	10	2.3	6.0	3.8	2.4	1.4	5.2	2.5
36681.W3516	M 3,5	16	2.3	6.0	3.8	2.4	1.4	5.2	2.5
36681.W3520	M 3,5	20	2.3	6.0	3.8	2.4	1.4	5.2	2.5
36681.W3525	M 3,5	25	2.3	6.0	3.8	2.4	1.4	5.2	2.5
36681.W3530	M 3,5	30	2.3	6.0	3.8	2.4	1.4	5.2	2.5
36681.W3540	M 3,5	40	2.3	6.0	3.8	2.4	1.4	5.2	2.5
36681.W4012	M 4	12	2.8	7.0	4.5	2.6	1.6	6.0	2.5
36681.W4016	M 4	16	2.8	7.0	4.5	2.6	1.6	6.0	2.5
36681.W4018	M 4	18	2.8	7.0	4.5	2.6	1.6	6.0	2.5
36681.W4019	M 4	19	2.8	7.0	4.5	2.6	1.6	6.0	2.5



Captive Screws - Cheese Head

hex drive - 303 stainless



Captive Screws

Order No.	d ₁	l ₁ ±0.25	d ₂ ±0.12	d ₃	d ₄ min.	h ₁	h ₂	l ₂ ±0.25	A/F
36681.W4020	M 4	20	2.8	7.0	4.5	2.6	1.6	6.0	2.5
36681.W4025	M 4	25	2.8	7.0	4.5	2.6	1.6	6.0	2.5
36681.W4030	M 4	30	2.8	7.0	4.5	2.6	1.6	6.0	2.5
36681.W4040	M 4	40	2.8	7.0	4.5	2.6	1.6	6.0	2.5
36681.W4050	M 4	50	2.8	7.0	4.5	2.6	1.6	6.0	2.5
36681.W4060	M 4	60	2.8	7.0	4.5	2.6	1.6	6.0	2.5
36681.W5012	M 5	12	3.7	8.5	5.5	3.3	2.0	7.5	3
36681.W5016	M 5	16	3.7	8.5	5.5	3.3	2.0	7.5	3
36681.W5020	M 5	20	3.7	8.5	5.5	3.3	2.0	7.5	3
36681.W5022	M 5	22	3.7	8.5	5.5	3.3	2.0	7.5	3
36681.W5025	M 5	25	3.7	8.5	5.5	3.3	2.0	7.5	3
36681.W5030	M 5	30	3.7	8.5	5.5	3.3	2.0	7.5	3
36681.W5040	M 5	40	3.7	8.5	5.5	3.3	2.0	7.5	3
36681.W5050	M 5	50	3.7	8.5	5.5	3.3	2.0	7.5	3
36681.W5060	M 5	60	3.7	8.5	5.5	3.3	2.0	7.5	3
36681.W5080	M 5	80	3.7	8.5	5.5	3.3	2.0	7.5	3
36681.W6016	M 6	16	4.2	10.0	6.5	3.9	2.3	7.5	4
36681.W6020	M 6	20	4.2	10.0	6.5	3.9	2.3	7.5	4
36681.W6025	M 6	25	4.2	10.0	6.5	3.9	2.3	7.5	4
36681.W6030	M 6	30	4.2	10.0	6.5	3.9	2.3	7.5	4
36681.W6040	M 6	40	4.2	10.0	6.5	3.9	2.3	7.5	4
36681.W6050	M 6	50	4.2	10.0	6.5	3.9	2.3	7.5	4
36681.W6060	M 6	60	4.2	10.0	6.5	3.9	2.3	7.5	4
36681.W6080	M 6	80	4.2	10.0	6.5	3.9	2.3	7.5	4

CAPTIVE SCREWS



MADE IN BRITAIN

36682

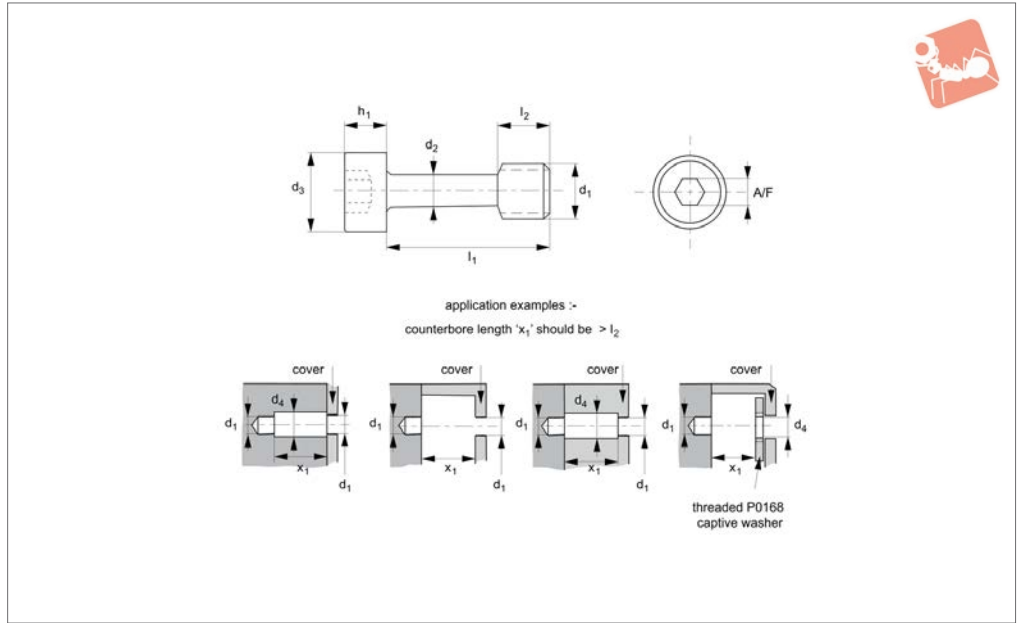

CAPTIVE SCREWS

Material

Stainless steel (AISI 303, 1.4305). Tensile strength 550 N/mm². Proof stress min. 190 N/mm², austenitic stainless steel. Also available on request in steel (anodised, black oxide or zinc plated), stainless steel (AISI 316, 1.440), brass, aluminium etc.

Technical Notes

Used to comply with the Machinery Direc-

tive 2006/42/EC. Generally to ISO 4762.

Often used with our captive washers (36691) or retaining flanges (36692 - for sheet metal applications). The use of our captive washers should be considered when fitted in panels with unthreaded holes.

Tips

TX drive style also available.

Important Notes

Please note that these screws have a reduced diameter shank and should not be tightened to the recommended torque for an equivalent machine screw of size d₁.

Order No.	d ₁	l ₁ ±0.25	d ₂ ±0.12	d ₃ max.	d ₄ min.	h ₁ max.	h ₂	l ₂ ±0.25	A/F	Drive #
36682.W0205	M 2,5	5	1.8	4.5	2.8	2.5	-	3.0	2	-
36682.W0208	M 2,5	8	1.8	4.5	2.8	2.5	-	3.0	2	-
36682.W0210	M 2,5	10	1.8	4.5	2.8	2.5	-	3.0	2	-
36682.W0212	M 2,5	12	1.8	4.5	2.8	2.5	-	3.0	2	-
36682.W0308	M 3	8	2.0	5.5	3.5	3.0	-	4.5	2.5	-
36682.W0310	M 3	10	2.0	5.5	3.5	3.0	-	4.5	2.5	-
36682.W0312	M 3	12	2.0	5.5	3.5	3.0	-	4.5	2.5	-
36682.W0316	M 3	16	2.0	5.5	3.5	3.0	-	4.5	2.5	-
36682.W0320	M 3	20	2.0	5.5	3.5	3.0	-	4.5	2.5	-
36682.W0325	M 3	25	2.0	5.5	3.5	3.0	-	4.5	2.5	-
36682.W0330	M 3	30	2.0	5.5	3.5	3.0	-	4.5	2.5	-
36682.W0412	M 4	12	2.8	7.0	4.5	4.0	-	6.0	3	-
36682.W0416	M 4	16	2.8	7.0	4.5	4.0	-	6.0	3	-
36682.W0420	M 4	20	2.8	7.0	4.5	4.0	-	6.0	3	-
36682.W0425	M 4	25	2.8	7.0	4.5	4.0	-	6.0	3	-
36682.W0430	M 4	30	2.8	7.0	4.5	4.0	-	6.0	3	-
36682.W0440	M 4	40	2.8	7.0	4.5	4.0	-	6.0	3	-
36682.W0450	M 4	50	2.8	7.0	4.5	4.0	-	6.0	3	-
36682.W0512	M 5	12	3.7	8.5	5.5	5.0	-	7.5	4	-
36682.W0516	M 5	16	3.7	8.5	5.5	5.0	-	7.5	4	-
36682.W0520	M 5	20	3.7	8.5	5.5	5.0	-	7.5	4	-
36682.W0525	M 5	25	3.7	8.5	5.5	5.0	-	7.5	4	-
36682.W0530	M 5	30	3.7	8.5	5.5	5.0	-	7.5	4	-
36682.W0535	M 5	35	3.7	8.5	5.5	5.0	-	7.5	4	-
36683.W0311	M 3	10	2.0	5.6	4.5	2.4	0.74	4.5	-	1
36682.W0540	M 5	40	3.7	8.5	5.5	5.0	-	7.5	4	-



Captive Screws - Cap Head

hex drive - 303 stainless



Captive Screws

Order No.	d ₁	l ₁ ±0.25	d ₂ ±0.12	d ₃ max.	d ₄ min.	h ₁ max.	h ₂	l ₂ ±0.25	A/F	Drive #
36682.W0550	M 5	50	3.7	8.5	5.5	5.0	-	7.5	4	-
36682.W0612	M 6	12	4.2	10.0	6.5	6.0	-	7.5	5	-
36682.W0616	M 6	16	4.2	10.0	6.5	6.0	-	7.5	5	-
36682.W0620	M 6	20	4.2	10.0	6.5	6.0	-	7.5	5	-
36682.W0625	M 6	25	4.2	10.0	6.5	6.0	-	7.5	5	-
36682.W0630	M 6	30	4.2	10.0	6.5	6.0	-	7.5	5	-
36682.W0640	M 6	40	4.2	10.0	6.5	6.0	-	7.5	5	-
36682.W0650	M 6	50	4.2	10.0	6.5	6.0	-	7.5	5	-
36682.W0660	M 6	60	4.2	10.0	6.5	6.0	-	7.5	5	-
36682.W0680	M 6	80	4.2	10.0	6.5	6.0	-	7.5	5	-
36682.W0816	M 8	16	6.0	13.0	8.5	8.0	-	10.0	6	-
36682.W0820	M 8	20	6.0	13.0	8.5	8.0	-	10.0	6	-
36682.W0825	M 8	25	6.0	13.0	8.5	8.0	-	10.0	6	-
36682.W0830	M 8	30	6.0	13.0	8.5	8.0	-	10.0	6	-
36682.W0835	M 8	35	6.0	13.0	8.5	8.0	-	10.0	6	-
36682.W0840	M 8	40	6.0	13.0	8.5	8.0	-	10.0	6	-
36682.W0845	M 8	45	6.0	13.0	8.5	8.0	-	10.0	6	-
36682.W0850	M 8	50	6.0	13.0	8.5	8.0	-	10.0	6	-
36682.W0860	M 8	60	6.0	13.0	8.5	8.0	-	10.0	6	-
36682.W0880	M 8	80	6.0	13.0	8.5	8.0	-	10.0	6	-
36682.W1020	M10	20	7.5	16.0	10.6	10.0	-	12.5	8	-
36682.W1025	M10	25	7.5	16.0	10.6	10.0	-	12.5	8	-
36682.W1030	M10	30	7.5	16.0	10.6	10.0	-	12.5	8	-
36682.W1035	M10	35	7.5	16.0	10.6	10.0	-	12.5	8	-
36682.W1040	M10	40	7.5	16.0	10.6	10.0	-	12.5	8	-
36682.W1045	M10	45	7.5	16.0	10.6	10.0	-	12.5	8	-
36682.W1050	M10	50	7.5	16.0	10.6	10.0	-	12.5	8	-
36682.W1060	M10	60	7.5	16.0	10.6	10.0	-	12.5	8	-
36682.W1080	M10	80	7.5	16.0	10.6	10.0	-	12.5	8	-
36682.W1225	M12	25	8.0	18.0	13.2	12.0	-	15.0	10	-
36682.W1230	M12	30	8.0	18.0	13.2	12.0	-	15.0	10	-
36682.W1235	M12	35	8.0	18.0	13.2	12.0	-	15.0	10	-
36682.W1240	M12	40	8.0	18.0	13.2	12.0	-	15.0	10	-
36682.W1245	M12	45	8.0	18.0	13.2	12.0	-	15.0	10	-
36682.W1250	M12	50	8.0	18.0	13.2	12.0	-	15.0	10	-
36682.W1260	M12	60	8.0	18.0	13.2	12.0	-	15.0	10	-
36682.W1280	M12	80	8.0	18.0	13.2	12.0	-	15.0	10	-

CAPTIVE SCREWS



MADE IN BRITAIN

36683

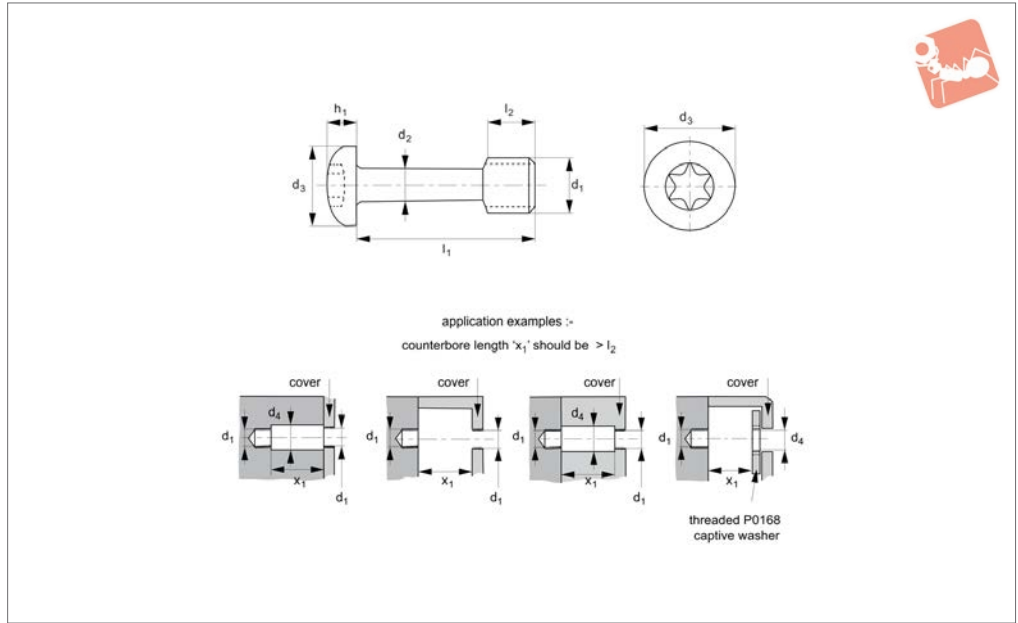

CAPTIVE SCREWS

Material

Stainless steel (AISI 303, 1.4305). Tensile strength 550 N/mm². Proof stress min. 190 N/mm², austenitic stainless steel. Also available on request in steel (anodised, black oxide or zinc plated), stainless steel (AISI 316, 1.440), brass, aluminium etc.

Technical Notes

Used to comply with the Machinery Direc-

tive 2006/42/EC. Generally to ISO 14583. Often used with our captive washers (36691) or retaining flanges (P0169 - for sheet metal applications). The use of our captive washers should be considered when fitted in panels with unthreaded holes.

* M 8 sizes have a reduced TX size.

Important Notes

Please note that these screws have a

reduced diameter shank and should not be tightened to the recommended torque for an equivalent machine screw of size d₁.

Order No.	d ₁	l ₁ ±0.25	d ₂ ±0.12	d ₃ max.	d ₄ min.	h ₁ max.	l ₂ ±0.25	TX size
36683.W0310	M 3	10	2.0	6	3.5	2.5	4.5	TX-10
36683.W0316	M 3	16	2.0	6	3.5	2.5	4.5	TX-10
36683.W0320	M 3	20	2.0	6	3.5	2.5	4.5	TX-10
36683.W0325	M 3	25	2.0	6	3.5	2.5	4.5	TX-10
36683.W0330	M 3	30	2.0	6	3.5	2.5	4.5	TX-10
36683.W0412	M 4	12	2.8	8	4.5	3.2	6.0	TX-20
36683.W0416	M 4	16	2.8	8	4.5	3.2	6.0	TX-20
36683.W0420	M 4	20	2.8	8	4.5	3.2	6.0	TX-20
36683.W0430	M 4	30	2.8	8	4.5	3.2	6.0	TX-20
36683.W0440	M 4	40	2.8	8	4.5	3.2	6.0	TX-20
36683.W0450	M 4	50	2.8	8	4.5	3.2	6.0	TX-20
36683.W0512	M 5	12	3.7	10	5.5	3.9	7.5	TX-25
36683.W0516	M 5	16	3.7	10	5.5	3.9	7.5	TX-25
36683.W0530	M 5	30	3.7	10	5.5	3.9	7.5	TX-25
36683.W0540	M 5	40	3.7	10	5.5	3.9	7.5	TX-25
36683.W0550	M 5	50	3.7	10	5.5	3.9	7.5	TX-25
36683.W0612	M 6	12	4.2	12	6.5	4.7	7.5	TX-30
36683.W0616	M 6	16	4.2	12	6.5	4.7	7.5	TX-30
36683.W0620	M 6	20	4.2	12	6.5	4.7	7.5	TX-30
36683.W0630	M 6	30	4.2	12	6.5	4.7	7.5	TX-30
36683.W0640	M 6	40	4.2	12	6.5	4.7	7.5	TX-30
36683.W0650	M 6	50	4.2	12	6.5	4.7	7.5	TX-30
36683.W0660	M 6	60	4.2	12	6.5	4.7	7.5	TX-30



Captive Screws - Countersunk hex drive - 303 stainless

Captive Screws



36684

CAPTIVE SCREWS

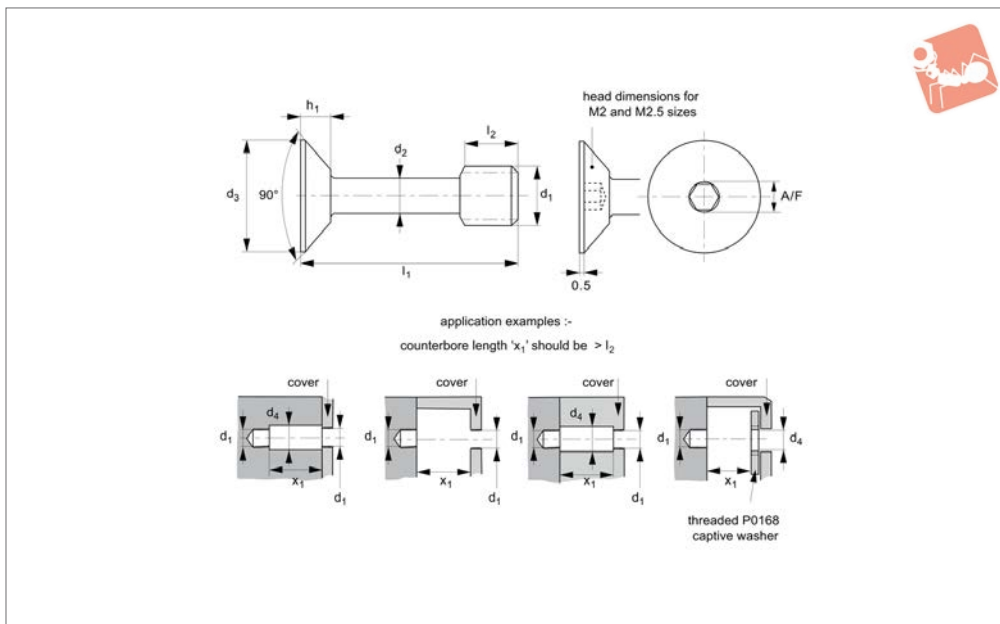

Material

Stainless steel (AISI 303, 1.4305). Tensile strength 550 N/mm². Proof stress min. 190 N/mm², austenitic stainless steel. Also available on request in steel (anodised, black oxide or zinc plated), brass, aluminium etc.

Technical Notes

Used to comply with the Machinery Direc-

tive 2006/42/EC. Often used with our captive washers (36691) or retaining flanges (P0169 - for sheet metal applications). The use of our captive washers should be considered when fitted in panels with unthreaded holes.

Important Notes

Please note that these screws have a reduced diameter shank and should not be

tightened to the recommended torque for an equivalent machine screw of size d₁. To accommodate the slight undercut at the top of the shank, the hex socket is smaller than on a similar threaded machine screw.

Order No.	d ₁	l ₁ ±0.25	d ₂ ±0.12	d ₃ max.	d ₄ min.	h ₁ max.	l ₂ ±0.25	A/F
36684.W0210	M 2	10	1.2	3.8	2.5	1.20	3.5	1.0
36684.W0212	M 2	12	1.2	3.8	2.5	1.20	3.5	1.0
36684.W0216	M 2	16	1.2	3.8	2.5	1.20	3.5	1.0
36684.W0220	M 2	20	1.2	3.8	2.5	1.20	3.5	1.0
36684.W0251	M 2,5	10	1.7	4.7	2.8	1.80	3.7	1.3
36684.W0252	M 2,5	12	1.7	4.7	2.8	1.80	3.7	1.3
36684.W0253	M 2,5	16	1.7	4.7	2.8	1.80	3.7	1.3
36684.W0254	M 2,5	20	1.7	4.7	2.8	1.80	3.7	1.3
36684.W0310	M 3	10	2.0	5.6	3.5	1.65	4.5	1.5
36684.W0316	M 3	16	2.0	5.6	3.5	1.65	4.5	1.5
36684.W0320	M 3	20	2.0	5.6	3.5	1.65	4.5	1.5
36684.W0325	M 3	25	2.0	5.6	3.5	1.65	4.5	1.5
36684.W0330	M 3	30	2.0	5.6	3.5	1.65	4.5	1.5
36684.W0340	M 3	40	2.0	5.6	3.5	1.65	4.5	1.5
36684.W0412	M 4	12	2.8	7.5	4.5	2.20	6.0	2.0
36684.W0416	M 4	16	2.8	7.5	4.5	2.20	6.0	2.0
36684.W0420	M 4	20	2.8	7.5	4.5	2.20	6.0	2.0
36684.W0430	M 4	30	2.8	7.5	4.5	2.20	6.0	2.0
36684.W0440	M 4	40	2.8	7.5	4.5	2.20	6.0	2.0
36684.W0450	M 4	50	2.8	7.5	4.5	2.20	6.0	2.0
36684.W0460	M 4	60	2.8	7.5	4.5	2.20	6.0	2.0
36684.W0512	M 5	12	3.7	9.2	5.5	2.50	7.5	2.5
36684.W0516	M 5	16	3.7	9.2	5.5	2.50	7.5	2.5
36684.W0520	M 5	20	3.7	9.2	5.5	2.50	7.5	2.5
36684.W0525	M 5	25	3.7	9.2	5.5	2.50	7.5	2.5
36684.W0530	M 5	30	3.7	9.2	5.5	2.50	7.5	2.5
36684.W0540	M 5	40	3.7	9.2	5.5	2.50	7.5	2.5
36684.W0550	M 5	50	3.7	9.2	5.5	2.50	7.5	2.5



Order No.	d ₁	l ₁ ±0.25	d ₂ ±0.12	d ₃ max.	d ₄ min.	h ₁ max.	l ₂ ±0.25	A/F
36684.W0560	M 5	60	3.7	9.2	5.5	2.50	7.5	2.5
36684.W0616	M 6	16	4.2	11.0	6.5	3.00	8.0	3.0
36684.W0620	M 6	20	4.2	11.0	6.5	3.00	8.0	3.0
36684.W0625	M 6	25	4.2	11.0	6.5	3.00	8.0	3.0
36684.W0630	M 6	30	4.2	11.0	6.5	3.00	8.0	3.0
36684.W0640	M 6	40	4.2	11.0	6.5	3.00	8.0	3.0
36684.W0650	M 6	50	4.2	11.0	6.5	3.00	8.0	3.0
36684.W0660	M 6	60	4.2	11.0	6.5	3.00	8.0	3.0
36684.W0820	M 8	20	6.0	15.0	8.5	4.10	10.0	4.0

CAPTIVE SCREWS



Coatings and Drive Types

Wixroyd produce a wide range of fasteners designed for application where it is important that fasteners are not separated from equipment (e.g. cover panels etc). This is now important to ensure that equipment complies with Machinery Directive 200642/EC - requiring that fasteners remain attached to fixed guards or equipment when guards are removed.





Our captive panel screws are manufactured mainly from stainless steel (AISI 303, 1.4305 grade), but they can also be produced in stainless steel (A4, AISI 316), aluminium, brass or zinc plated steel.

Many finishes can be applied - black oxide finish, anodizing etc.

The main options are as follows:

Finish	Notes
Black Chrome (MIL-C-1458B)	Black chrome is a hard, non-reflective coating which is resistant to abrasion, heat and corrosion. The black chrome surface is a dull, dark grey and may be waxed or oiled to darken surface.
Black Oxide Coating (MIL-C-13924B)	Black oxide is a uniform black coating for ferrous metals. Generally it is considered a decorative coating and provides only very limited corrosion protection under mild corrosion conditions.
Cadmium	Cadmium is a bright, silvery white plating. Supplementary treatments for Type II can be golden, iridescent, amber, black or olive drab.
Passivate (QQ-P-35/MIL S-500SC)	Passivation is a process designed to remove foreign metals from the surface of stainless and corrosion resistant steels.
Phosphate Coating Light (TT-C-00490B)	Phosphate coating is a light coating for use as a base paint.
Gold (MIL-G-45204B)	Yellow to orange colour depending on proprietary process used. Will range from matt to bright finish depending on base metal. Good corrosion resistance and high tarnish resistance.
Nickel (QQ-N-290A)	Nickel is a corrosion protective plating for steel, zinc and zinc alloys as well as copper and copper alloys.
Zinc (QQ-Z-325C)	The primary use of chromate finishes on zinc is to retard or prevent formation of white corrosion products on zinc surfaces.

Coatings

Schematic	Drive Types	Uses
	Hexagonal	Ideal for precision assembly. Most recommended where less surface area is available.
	Crosshead (Phillips®)	Provides good control in driving. Always use a driver bit of the proper size which is in good condition.
	Hexalobular (Torx®)	Positive-engaging, fast-locating method which transmits drive torque with less required downward pressure. Good fastening appearance.
	Slotted	Accepts standard blade screwdriver. Requires less downward pressure to drive parts than those with recessed openings. Use a proper fitting blade to minimize slippage.
	Security	These screws are impossible to remove without the special matching screw driver.

Drive Types

ov-W36681-AP0152.A2-T-W36692-AP0169.A2-T-captive-screws-selection-a-rmh - Updated - 28-10-2022



36681 - Cap head - hex. socket



36682 - Cap head - hex. socket Security and Torx® options

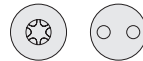

36683 - Pan Head - Phillips® Security and Torx® options

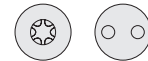

36684 - Countersunk - hex. socket Security and Torx® options

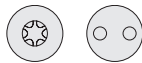

36686 - Thin head thumb screw



36687 - Thumb screw

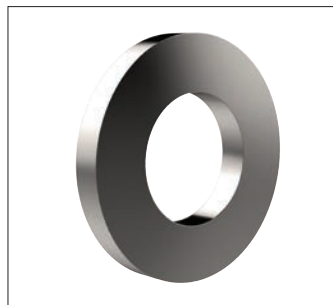

36691 - Threaded captive washers



36692 - Retainer flanges



One option to retain screws to panels are our retaining washers. Used in place of retainer flanges, retaining washers are simple but effective when used with our captive screws. The captive screws have a normal thread then a reduced diameter for the rest of the screw length.

The retaining washer has a small length of thread on the internal diameter and once screwed on to the captive screw is effectively captive.

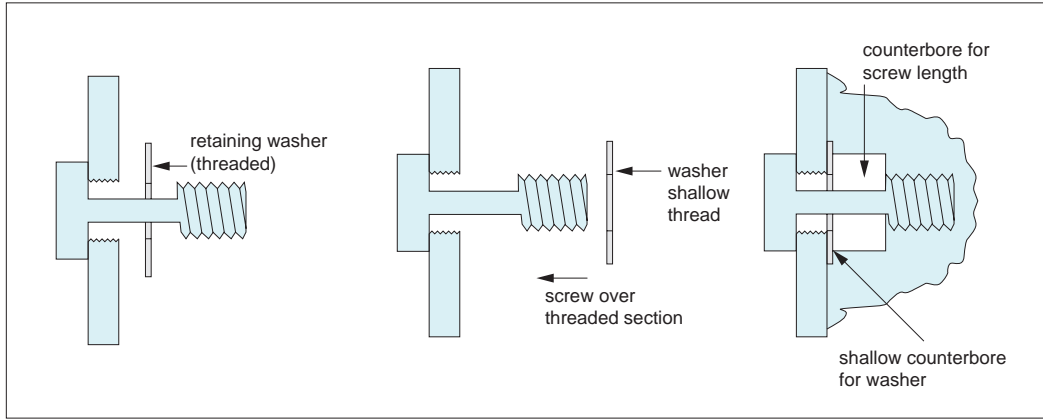

Example

Screw the thin retaining washer onto the captive screw and the screw is therefore retained to the panel.

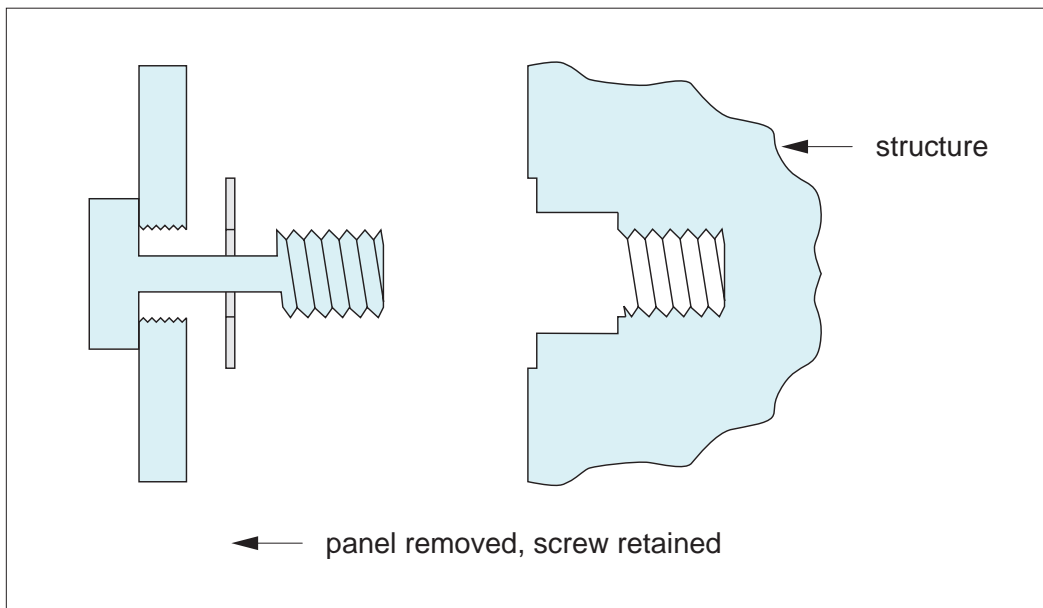

CAPTIVE SCREWS



MADE IN BRITAIN

36686

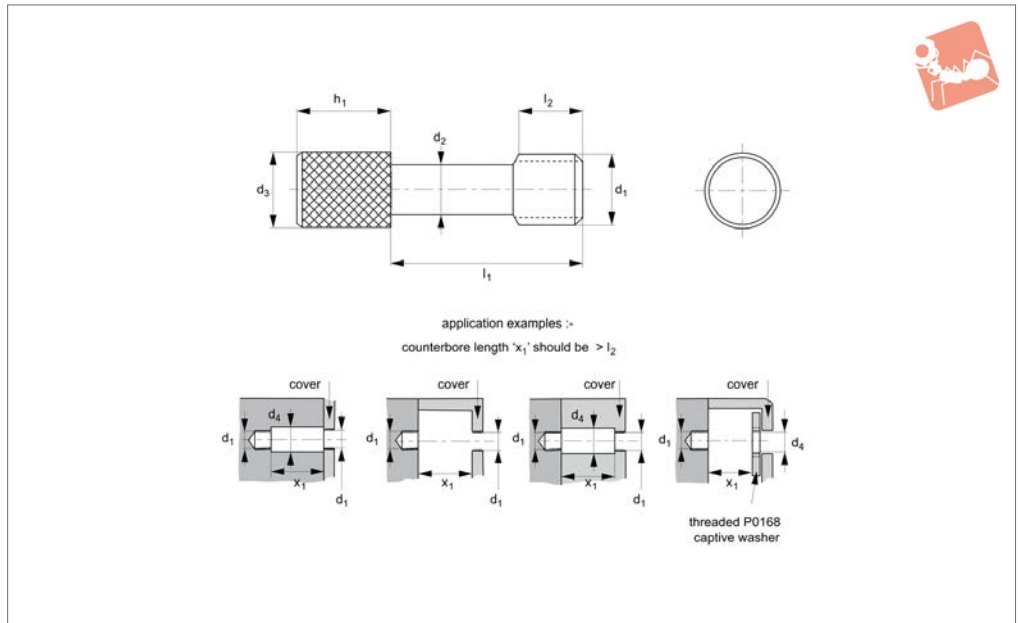

CAPTIVE SCREWS

Material

Stainless steel (AISI 303, 1.4305). Tensile strength 550 N/mm². Proof stress min. 190 N/mm², austenitic stainless steel. Also available on request in steel (anodised, black oxide or zinc plated), stainless steel (AISI 316, 1.440), brass, aluminium etc.

Technical Notes

Used to comply with the Machinery Directive 2006/42/EC. Often used with our captive washers (36691) or retaining flanges (P0169 - for sheet metal applications). The use of our captive washers should be considered when fitted in panels with unthreaded holes.

Important Notes

Please note that these screws have a reduced diameter shank and should not be tightened to the recommended torque for an equivalent machine screw of size d₁.

Order No.	d ₁	d ₂ ±0.12	l ₁ ±0.25	l ₂ ±0.25	d ₃	d ₄ min.	h ₁
36686.W0316	M 3	2.0	16	8.0	5	3.5	10
36686.W0320	M 3	2.0	20	10.0	5	3.5	10
36686.W0325	M 3	2.0	25	12.5	5	3.5	10
36686.W0330	M 3	2.0	30	15.0	5	3.5	10
36686.W0335	M 3	2.0	35	17.5	5	3.5	10
36686.W0340	M 3	2.0	40	20.0	5	3.5	10
36686.W0350	M 3	2.0	50	25.0	5	3.5	10
36686.W0351	M 3,5	2.3	16	8.0	5	3.8	10
36686.W0352	M 3,5	2.3	20	10.0	5	3.8	10
36686.W0353	M 3,5	2.3	25	12.5	5	3.8	10
36686.W0354	M 3,5	2.3	30	15.0	5	3.8	10
36686.W0355	M 3,5	2.3	35	17.5	5	3.8	10
36686.W0356	M 3,5	2.3	40	20.0	5	3.8	10
36686.W0357	M 3,5	2.3	50	25.0	5	3.8	10
36686.W0416	M 4	2.8	16	8.0	5	4.5	10
36686.W0420	M 4	2.8	20	10.0	5	4.5	10
36686.W0425	M 4	2.8	25	12.5	5	4.5	10
36686.W0430	M 4	2.8	30	15.0	5	4.5	10
36686.W0435	M 4	2.8	35	17.5	5	4.5	10
36686.W0440	M 4	2.8	40	20.0	5	4.5	10
36686.W0450	M 4	2.8	50	25.0	5	4.5	10
36686.W0516	M 5	3.7	16	8.0	6	5.5	12
36686.W0520	M 5	3.7	20	10.0	6	5.5	12
36686.W0525	M 5	3.7	25	12.5	6	5.5	12
36686.W0530	M 5	3.7	30	15.0	6	5.5	12
36686.W0535	M 5	3.7	35	17.5	6	5.5	12
36686.W0540	M 5	3.7	40	24.0	6	5.5	12
36686.W0550	M 5	3.7	50	25.0	6	5.5	12
36686.W0616	M 6	4.2	16	8.0	8	6.5	12



Captive Thumb Screws

303 stainless



Captive Screws

Order No.	d ₁	d ₂ ±0.12	l ₁ ±0.25	l ₂ ±0.25	d ₃	d ₄ min.	h ₁
36686.W0620	M 6	4.2	20	10.0	8	6.5	12
36686.W0625	M 6	4.2	25	12.5	8	6.5	12
36686.W0630	M 6	4.2	30	15.0	8	6.5	12
36686.W0635	M 6	4.2	35	17.5	8	6.5	12
36686.W0640	M 6	4.2	40	20.0	8	6.5	12
36686.W0650	M 6	4.2	50	25.0	8	6.5	12

CAPTIVE SCREWS



MADE IN BRITAIN

36687

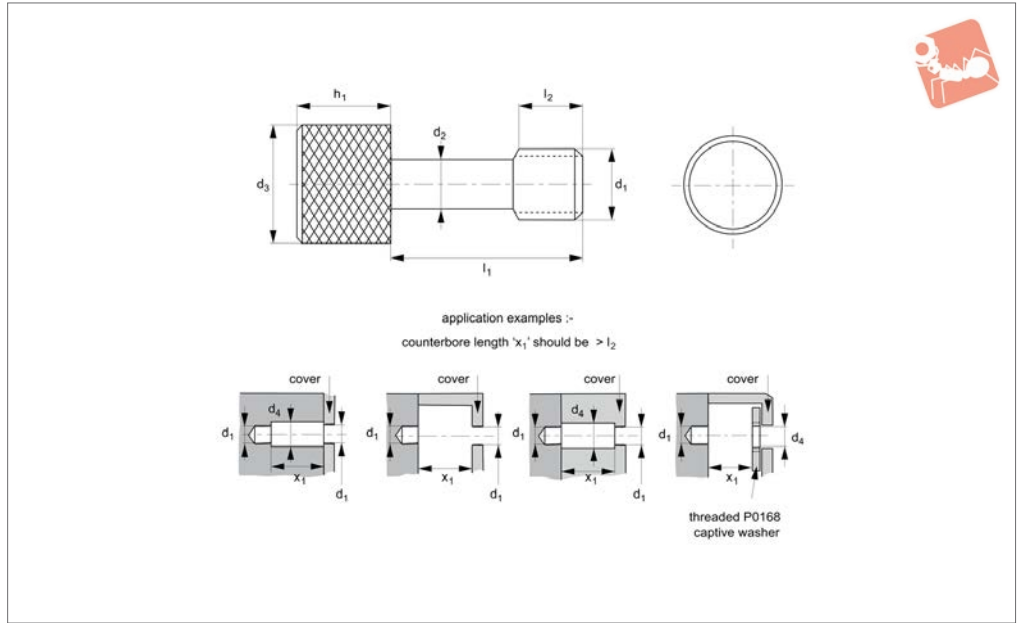

CAPTIVE SCREWS

Material

Stainless steel (AISI 303, 1.4305). Tensile strength 550 N/mm². Proof stress min. 190 N/mm², austenitic stainless steel. Also available on request in steel (anodised, black oxide or zinc plated), stainless steel (AISI 316, 1.440), brass, aluminium etc.

Technical Notes

Used to comply with the Machinery Directive 2006/42/EC. Often used with our captive washer (36691) or retaining flanges (P0169 - for sheet metal applications). The use of our captive washer should be considered when fitted in panels with unthreaded holes.

Important Notes

Please note that these screws have a reduced diameter shank and should not be tightened to the recommended torque for an equivalent machine screw of size d₁.

Order No.	d ₁	d ₂ ±0.12	l ₁ ±0.25	l ₂ ±0.25	d ₃	d ₄ min.	h ₁
36687.W3008	M 3	2.0	8	4.5	8	3.5	5
36687.W3010	M 3	2.0	10	4.5	8	3.5	5
36687.W3012	M 3	2.0	12	4.5	8	3.5	5
36687.W3014	M 3	2.0	14	4.5	8	3.5	5
36687.W3016	M 3	2.0	16	4.5	8	3.5	5
36687.W3508	M 3,5	2.3	8	6.0	8	3.8	5
36687.W3510	M 3,5	2.3	10	6.0	8	3.8	5
36687.W3512	M 3,5	2.3	12	6.0	8	3.8	5
36687.W3514	M 3,5	2.3	14	6.0	8	3.8	5
36687.W3516	M 3,5	2.3	16	6.0	8	3.8	5
36687.W4010	M 4	2.8	10	6.0	10	4.5	5
36687.W4012	M 4	2.8	12	6.0	10	4.5	5
36687.W4014	M 4	2.8	14	6.0	10	4.5	5
36687.W4016	M 4	2.8	16	6.0	10	4.5	5
36687.W4018	M 4	2.8	18	6.0	10	4.5	5
36687.W4020	M 4	2.8	20	6.0	10	4.5	5
36687.W4025	M 4	2.8	25	6.0	10	4.5	5
36687.W5010	M 5	3.7	10	7.5	10	5.5	5
36687.W5012	M 5	3.7	12	7.5	10	5.5	5
36687.W5014	M 5	3.7	14	7.5	10	5.5	5
36687.W5016	M 5	3.7	16	7.5	10	5.5	5
36687.W5018	M 5	3.7	18	7.5	10	5.5	5
36687.W5020	M 5	3.7	20	7.5	10	5.5	5
36687.W5025	M 5	3.7	25	7.5	10	5.5	5
36687.W5030	M 5	3.7	30	7.5	10	5.5	5
36687.W6013	M 6	4.5	12	7.5	12	6.5	6
36687.W6014	M 6	4.5	14	7.5	12	6.5	6
36687.W6016	M 6	4.5	16	7.5	12	6.5	6
36687.W6018	M 6	4.5	18	7.5	12	6.5	6



Captive Thumb Screws

303 stainless



Captive Screws

Order No.	d ₁	d ₂ ±0.12	l ₁ ±0.25	l ₂ ±0.25	d ₃	d ₄ min.	h ₁
36687.W6020	M 6	4.5	20	7.5	12	6.5	6
36687.W6025	M 6	4.5	25	7.5	12	6.5	6
36687.W6030	M 6	4.5	30	7.5	12	6.5	6

CAPTIVE SCREWS



36692

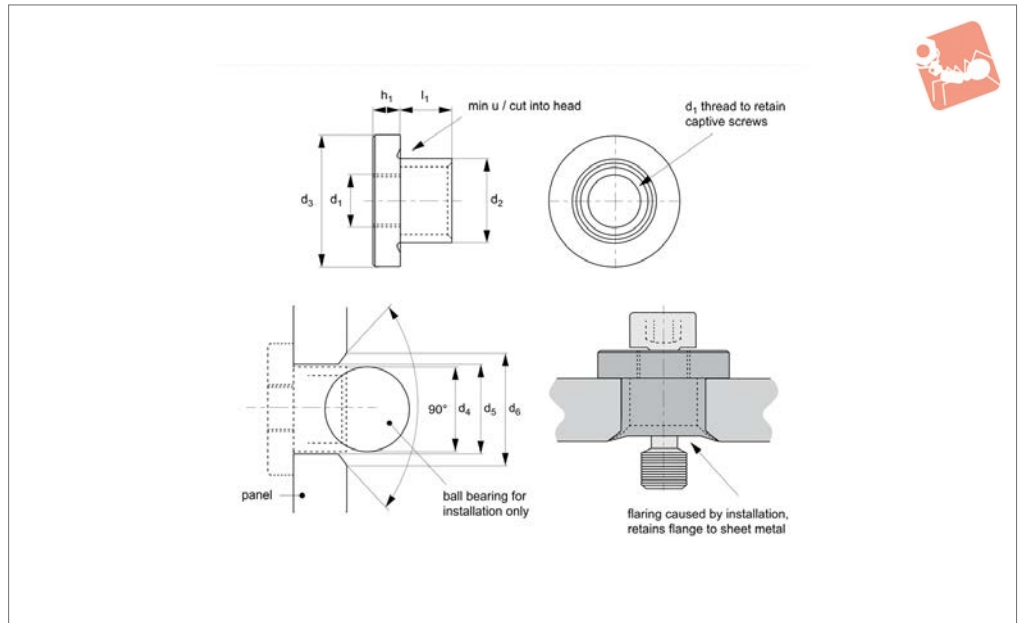

Material

Stainless steel (AISI 303, 1.4305).
 Also available on request in steel (anodised, black oxide or zinc plated) stainless steel (AISI 316, 1.440), brass.

Technical Notes

Select the retainer flange to suit thread of

the captive screw and the thickness of the panel to be retained.

Drill and countersink hole in the panel and use the ball bearing supplied to spread the flange into the countersunk hole.

The captive screw is then screwed into the flange and the screw is retained to the

panel.

Tips

Mounting hole diameter to H9 clearance. Countersunk d_6 to 90° .

Order No.	For thread d_1	Panel t_1 $\pm 8\%$	d_2	h_1	l_1	d_3	Installation ball dia. d_4	d_5 tol. H9	d_6	Sheet metal gauge
36692.W3007	M 3	0.70	5.0	1.5	0.70	7.5	5	5.0	6.0	22
36692.W3009	M 3	0.90	5.0	1.5	0.90	7.5	5	5.0	6.0	20
36692.W3012	M 3	1.25	5.0	1.5	1.25	7.5	5	5.0	6.0	18
36692.W3015	M 3	1.50	5.0	1.5	1.50	7.5	5	5.0	6.0	16
36692.W3020	M 3	2.00	5.0	1.5	2.00	7.5	5	5.0	6.0	14
36692.W3025	M 3	2.50	5.0	1.5	2.50	7.5	5	5.0	6.0	12
36692.W3030	M 3	3.00	5.0	1.5	3.00	7.5	5	5.0	6.0	10
36692.W3040	M 3	4.00	5.0	1.5	4.00	7.5	5	5.0	6.0	8
36692.W3050	M 3	5.00	5.0	1.5	5.00	7.5	5	5.0	6.0	6
36692.W3060	M 3	6.00	5.0	1.5	6.00	7.5	5	5.0	6.0	4
36692.W4007	M 4	0.70	6.8	2.0	0.70	10.0	7	6.8	8.2	22
36692.W4009	M 4	0.90	6.8	2.0	0.90	10.0	7	6.8	8.2	20
36692.W4012	M 4	1.25	6.8	2.0	1.25	10.0	7	6.8	8.2	18
36692.W4015	M 4	1.50	6.8	2.0	1.50	10.0	7	6.8	8.2	16
36692.W4020	M 4	2.00	6.8	2.0	2.00	10.0	7	6.8	8.2	14
36692.W4025	M 4	2.50	6.8	2.0	2.50	10.0	7	6.8	8.2	12
36692.W4030	M 4	3.00	6.8	2.0	3.00	10.0	7	6.8	8.2	10
36692.W4040	M 4	4.00	6.8	2.0	4.00	10.0	7	6.8	8.2	8
36692.W4050	M 4	5.00	6.8	2.0	5.00	10.0	7	6.8	8.2	6
36692.W4060	M 4	6.00	6.8	2.0	6.00	10.0	7	6.8	8.2	4
36692.W5007	M 5	0.70	8.0	2.5	0.70	12.5	8	8.0	9.6	22
36692.W5009	M 5	0.90	8.0	2.5	0.90	12.5	8	8.0	9.6	20
36692.W5012	M 5	1.25	8.0	2.5	1.25	12.5	8	8.0	9.6	18
36692.W5015	M 5	1.50	8.0	2.5	1.50	12.5	8	8.0	9.6	16
36692.W5020	M 5	2.00	8.0	2.5	2.00	12.5	8	8.0	9.6	14
36692.W5025	M 5	2.50	8.0	2.5	2.50	12.5	8	8.0	9.6	12
36692.W5030	M 5	3.00	8.0	2.5	3.00	12.5	8	8.0	9.6	10
36692.W5040	M 5	4.00	8.0	2.5	4.00	12.5	8	8.0	9.6	8
36692.W5050	M 5	5.00	8.0	2.5	5.00	12.5	8	8.0	9.6	6
36692.W5060	M 5	6.00	8.0	2.5	6.00	12.5	8	8.0	9.6	4



Captive Screws - Retainer Flange

303 stainless



Captive Screws

Order No.	For thread d ₁	Panel t ₁ ±8%	d ₂	h ₁	l ₁	d ₃	Installation ball dia. d ₄	d ₅ tol. H9	d ₆	Sheet metal gauge
36692.W6007	M 6	0.70	10.0	3.0	0.70	15.0	10	10.0	12.0	22
36692.W6009	M 6	0.90	10.0	3.0	0.90	15.0	10	10.0	12.0	20
36692.W6012	M 6	1.25	10.0	3.0	1.25	15.0	10	10.0	12.0	18
36692.W6015	M 6	1.50	10.0	3.0	1.50	15.0	10	10.0	12.0	16
36692.W6020	M 6	2.00	10.0	3.0	2.00	15.0	10	10.0	12.0	14
36692.W6025	M 6	2.50	10.0	3.0	2.50	15.0	10	10.0	12.0	12
36692.W6030	M 6	3.00	10.0	3.0	3.00	15.0	10	10.0	12.0	10
36692.W6040	M 6	4.00	10.0	3.0	4.00	15.0	10	10.0	12.0	8
36692.W6050	M 6	5.00	10.0	3.0	5.00	15.0	10	10.0	12.0	6
36692.W6060	M 6	6.00	10.0	3.0	6.00	15.0	10	10.0	12.0	4
36692.W8007	M 8	0.70	13.0	4.0	0.70	20.0	13	13.0	15.5	22
36692.W8009	M 8	0.90	13.0	4.0	0.90	20.0	13	13.0	15.5	20
36692.W8012	M 8	1.25	13.0	4.0	1.25	20.0	13	13.0	15.5	18
36692.W8015	M 8	1.50	13.0	4.0	1.50	20.0	13	13.0	15.5	16
36692.W8020	M 8	2.00	13.0	4.0	2.00	20.0	13	13.0	15.5	14
36692.W8025	M 8	2.50	13.0	4.0	2.50	20.0	13	13.0	15.5	12
36692.W8030	M 8	3.00	13.0	4.0	3.00	20.0	13	13.0	15.5	10
36692.W8040	M 8	4.00	13.0	4.0	4.00	20.0	13	13.0	15.5	8
36692.W8050	M 8	5.00	13.0	4.0	5.00	20.0	13	13.0	15.5	6
36692.W8060	M 8	6.00	13.0	4.0	6.00	20.0	13	13.0	15.5	4

CAPTIVE SCREWS



Preparation

- Select retainer based upon panel thickness
- Countersink panel

Wixroyd captive screw retainer flanges are available in both aluminium and stainless steel to suit the most common panel thicknesses. The retainer flange has a very shallow thread length on its internal diameter. A suitable hole is machined into the panel, and the underside of the hole is countersunk.

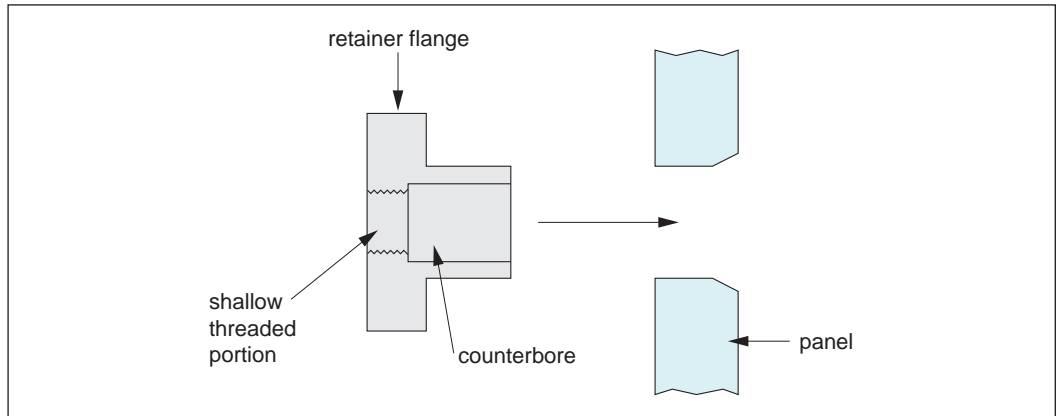

Mounting

- Insert flange
- Use ball bearing or punch to form flange into panel

The flange is then joined to the panel using either a simple ball bearing (or for higher volume parts a hand punch) to form the bottom of the flange into the countersink. This retains the flange to the sheet.

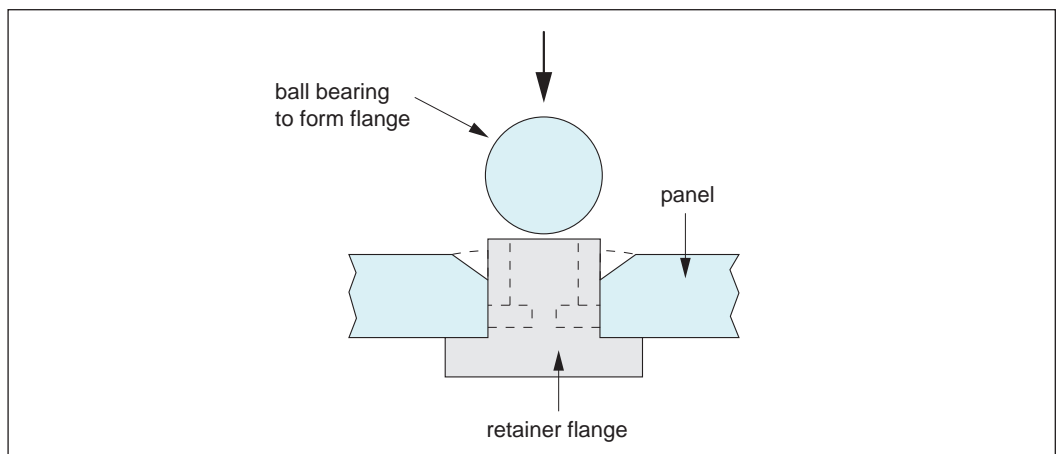

Retaining flange secured onto panel using ball bearing or punch

Captive Screw Assembly

The captive screw or bolt is then threaded onto the retainer flange and once the thread length is through the initial shallow threaded portion of the retainer flange – is captive.

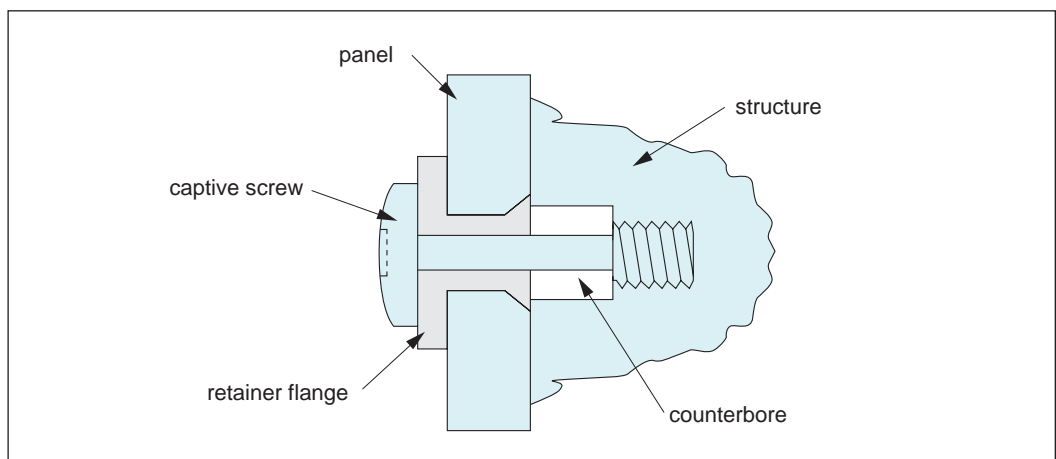

With any captive screw installation it is important to ensure that there is enough space for the threaded portion to become disengaged from the female thread of the structure.



Threaded Captive Washers for captive screws



Captive Screws

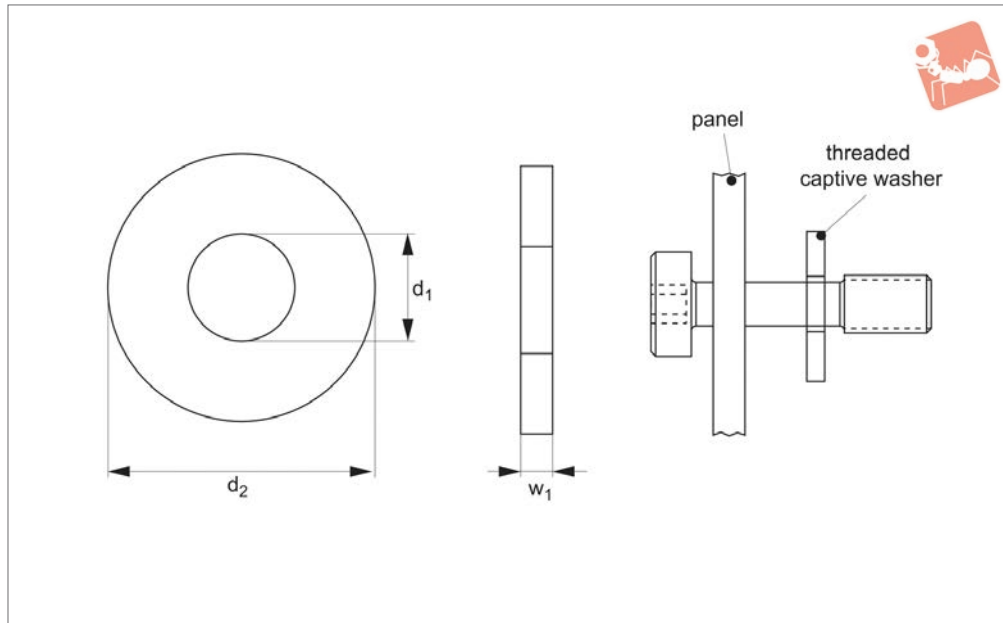

36691

CAPTIVE SCREWS

Material

Stainless steel (AISI 303, 1.4305 and AISI 316, 1.440), steel (zinc-plated or black-oxide) and titanium (grade 2 and grade 5).

Technical Notes

Captive washers have a very shallow thread on the i/d.

This enables them to be screwed on, and once past the threads they do not separate from the captive screw or bolt.

Tips

Captive washers are primarily used to retain captive screws in panels which have

unthreaded holes. The panel (onto which the screw needs to be retained) is placed onto the captive screw, the threaded washer is then threaded onto the screw, past the threaded section and the screw is therefore captive to the panel.

Order No.	d ₁	w ₁ ±0.05	d ₂	Material
36691.W0025	M 2,5	1.0	5.0	Stainless steel 303
36691.W0030	M 3	1.0	6.0	Stainless steel 303
36691.W0040	M 4	1.2	8.0	Stainless steel 303
36691.W0050	M 5	1.5	10.0	Stainless steel 303
36691.W0060	M 6	1.6	12.0	Stainless steel 303
36691.W0080	M 8	2.0	16.0	Stainless steel 303
36691.W0100	M10	3.0	20.0	Stainless steel 303
36691.W0120	M12	3.5	24.0	Stainless steel 303
36691.W1025	M 2,5	1.0	5.0	Stainless steel 316
36691.W1030	M 3	1.0	6.0	Stainless steel 316
36691.W1040	M 4	1.2	8.0	Stainless steel 316
36691.W1050	M 5	1.5	10.0	Stainless steel 316
36691.W1060	M 6	1.6	12.0	Stainless steel 316
36691.W1080	M 8	2.0	16.0	Stainless steel 316
36691.W1100	M10	3.0	20.0	Stainless steel 316
36691.W1120	M12	3.5	24.0	Stainless steel 316
36691.W2025	M 2,5	1.0	5.0	Zinc-plated steel
36691.W2030	M 3	1.0	6.0	Zinc-plated steel
36691.W2040	M 4	1.2	8.0	Zinc-plated steel
36691.W2050	M 5	1.5	10.0	Zinc-plated steel
36691.W2060	M 6	1.6	12.0	Zinc-plated steel
36691.W2080	M 8	2.0	16.0	Zinc-plated steel
36691.W2100	M10	3.0	20.0	Zinc-plated steel
36691.W2120	M12	3.5	24.0	Zinc-plated steel
36691.W0030-BL	M 3	1.0	6.0	Blackened steel
36691.W10-T5	M10	3.0	20.0	Grade 5 titanium
36691.W16-T5	M16	4.0	32.0	Grade 5 titanium



36630

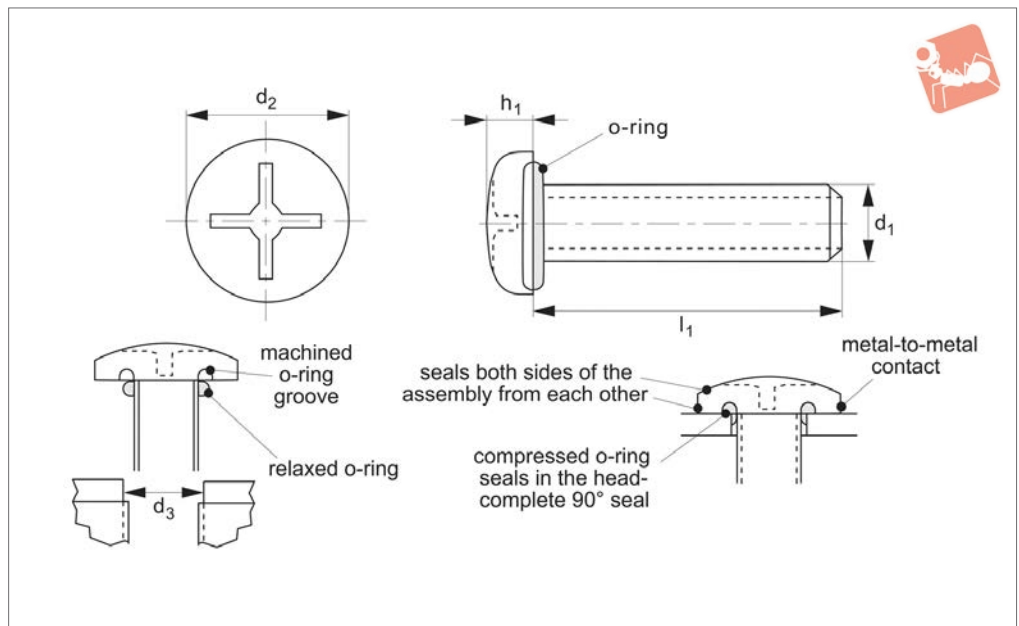

Material

Stainless steel (AISI 303 1.4305 tensile strength 550 N/mm²), with silicone „O“ ring as standard.

For other „O“ ring materials see technical data pages

(-FS = fluorosilicone, -EP = EPDM, -VI = viton, -NI = nitrile, -BN = Buna etc.).

Other thread lengths, and stainless steel

A4 (AISI 316) on request.

Technical Notes

Seals substances in and contaminants out, screws generally as DIN 7985 H, ISO 7045. Max temperature range: -100°C to +260°C, pressure range - up to 410 bar (6000 psi). Re-usable, also available (on request) with thread-locking.

Tips

Clearance holes recommended for maximum sealing performance (see dimensions below).

Clearance hole depth 2-3 x thread pitch, threads are metric coarse pitch.

Order No.	d ₁	l ₁	h ₁ max.	d ₂ max.	d ₃ ±0.05	Drive
36630.W0204	M 2	4	1.6	4.0	2.35	PH-1
36630.W0208	M 2	8	1.6	4.0	2.35	PH-1
36630.W0210	M 2	10	1.6	4.0	2.35	PH-1
36630.W0212	M 2	12	1.6	4.0	2.35	PH-1
36630.W0251	M2,5	6	2.1	4.7	2.75	PH-1
36630.W0252	M2,5	8	2.1	4.7	2.75	PH-1
36630.W0253	M2,5	10	2.1	4.7	2.75	PH-1
36630.W0254	M2,5	12	2.1	4.7	2.75	PH-1
36630.W0306	M 3	6	2.4	6.0	3.6	PH-1
36630.W0308	M 3	8	2.4	6.0	3.6	PH-1
36630.W0310	M 3	10	2.4	6.0	3.6	PH-1
36630.W0312	M 3	12	2.4	6.0	3.6	PH-1
36630.W0320	M 3	20	2.4	6.0	3.6	PH-1
36630.SP0335SI	M 3	35	2.4	6.0	3.6	PH-1
36630.W0406	M 4	6	3.1	8.0	4.5	PH-2
36630.W0408	M 4	8	3.1	8.0	4.5	PH-2
36630.W0410	M 4	10	3.1	8.0	4.5	PH-2
36630.W0412	M 4	12	3.1	8.0	4.5	PH-2
36630.W0416	M 4	16	3.1	8.0	4.5	PH-2
36630.W0420	M 4	20	3.1	8.0	4.5	PH-2
36630.W0508	M 5	8	3.7	10.0	5.6	PH-2
36630.W0510	M 5	10	3.7	10.0	5.6	PH-2
36630.W0512	M 5	12	3.7	10.0	5.6	PH-2
36630.W0516	M 5	16	3.7	10.0	5.6	PH-2
36630.W0520	M 5	20	1.6	10.0	5.6	PH-2
36630.W0612	M 6	12	4.6	12.0	6.8	PH-3
36630.W0616	M 6	16	4.6	12.0	6.8	PH-3
36630.W0620	M 6	20	4.6	12.0	6.8	PH-3



Pan Head Seal Screws

phillips drive



Sealing Screws

Order No.	d ₁	l ₁	h ₁ max.	d ₂ max.	d ₃ ±0.05	Drive
36630.W0625	M 6	25	4.6	12.0	6.8	PH-3
36630.W0630	M 6	30	4.6	12.0	6.8	PH-3
36630.W0812	M 8	12	6.0	16.0	8.5	PH-4
36630.W0816	M 8	16	6.0	16.0	8.5	PH-4
36630.W0820	M 8	20	6.0	16.0	8.5	PH-4
36630.W0825	M 8	25	6.0	16.0	8.5	PH-4
36630.W0830	M 8	30	6.0	16.0	8.5	PH-4
36630.W1016	M10	16	7.5	20.0	10.6	PH-4
36630.W1020	M10	20	7.5	20.0	10.6	PH-4
36630.W1025	M10	25	7.5	20.0	10.6	PH-4
36630.W1030	M10	30	7.5	20.0	10.6	PH-4
36630.W1040	M10	40	7.5	20.0	10.6	PH-4

SEALING SCREWS

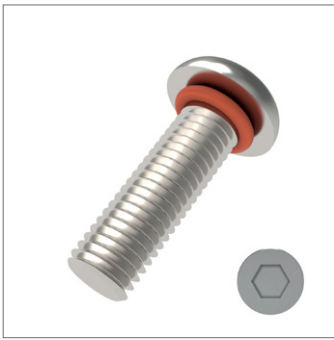

36631

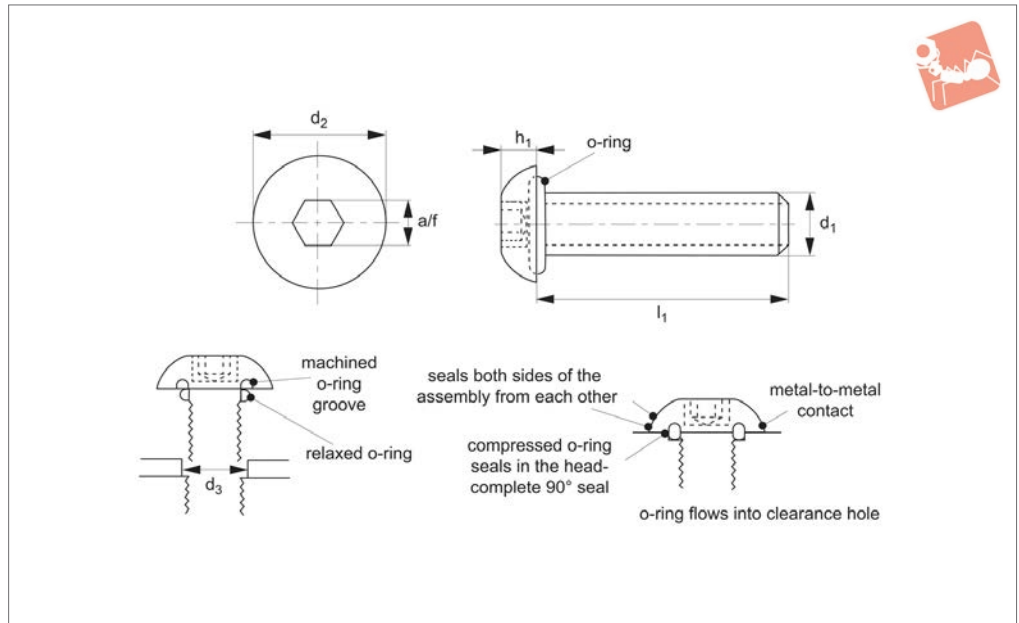

Material

Stainless steel (AISI 303 1.4305 tensile strength 550 N/mm² or AISI 316 1.440 tensile strength 480 N/mm²), with silicone „O” ring as standard.
 For other „O” ring materials see technical data pages
 (-FS = fluorosilicone, -EP = EPDM, -VI = viton, -NI = nitrile, -BN = Buna etc.).

Other thread lengths on request.

Technical Notes

Screws generally as ISO 7380, seals substances in and contaminants out.
 Re-useable. Clearance holes recommended for maximum sealing.
 Max temperature range: -100°C to +260°C,
 pressure range - up to 410 bar (6000 psi).

Also available (on request) with thread-locking.

Tips

Clearance holes recommended for maximum sealing performance (see dimensions below).
 Clearance hole depth 2-3 x thread pitch, threads are metric coarse pitch.

Order No.	d ₁	l ₁	h ₁ max.	d ₂ max.	A/F	d ₃ ±0.05	Material
36631.W0306	M 3	6	1.7	5.7	2	3.6	A2 s/s
36631.W0308	M 3	8	1.7	5.7	2	3.6	A2 s/s
36631.W0310	M 3	10	1.7	5.7	2	3.6	A2 s/s
36631.W0312	M 3	12	1.7	5.7	2	3.6	A2 s/s
36631.W0320	M 3	20	1.7	5.7	2	3.6	A2 s/s
36631.W0406	M 4	6	2.2	7.6	2.5	4.5	A2 s/s
36631.W0408	M 4	8	2.2	7.6	2.5	4.5	A2 s/s
36631.W0410	M 4	10	2.2	7.6	2.5	4.5	A2 s/s
36631.W0412	M 4	12	2.2	7.6	2.5	4.5	A2 s/s
36631.W0416	M 4	16	2.2	7.6	2.5	4.5	A2 s/s
36631.W0420	M 4	20	2.2	7.6	2.5	4.5	A2 s/s
36631.W0508	M 5	8	2.8	9.5	3	5.6	A2 s/s
36631.W0510	M 5	10	2.8	9.5	3	5.6	A2 s/s
36631.W0512	M 5	12	2.8	9.5	3	5.6	A2 s/s
36631.W0516	M 5	16	2.8	9.5	3	5.6	A2 s/s
36631.W0520	M 5	20	2.8	9.5	3	5.6	A2 s/s
36631.W0612	M 6	12	3.3	10.5	4	6.8	A2 s/s
36631.W0616	M 6	16	3.3	10.5	4	6.8	A2 s/s
36631.W0620	M 6	20	3.3	10.5	4	6.8	A2 s/s
36631.W0625	M 6	25	3.3	10.5	4	6.8	A2 s/s
36631.W0630	M 6	30	3.3	10.5	4	6.8	A2 s/s
36631.W0812	M 8	12	4.4	14.0	5	8.5	A2 s/s
36631.W0816	M 8	16	4.4	14.0	5	8.5	A2 s/s
36631.W0820	M 8	20	4.4	14.0	5	8.5	A2 s/s
36631.W0825	M 8	25	4.4	14.0	5	8.5	A2 s/s
36631.W0830	M 8	30	4.4	14.0	5	8.5	A2 s/s
36631.W1016	M10	16	5.5	17.5	6	10.6	A2 s/s
36631.W1020	M10	20	5.5	17.5	6	10.6	A2 s/s



Button Head Seal Screws

hex. socket



Sealing Screws

Order No.	d ₁	l ₁	h ₁ max.	d ₂ max.	A/F	d ₃ ±0.05	Material
36631.W1025	M10	25	5.5	17.5	6	10.6	A2 s/s
36631.W1030	M10	30	5.5	17.5	6	10.6	A2 s/s
36631.W1040	M10	40	5.5	17.5	6	10.6	A2 s/s
36631.W1220	M12	20	6.6	21.0	8	12.9	A2 s/s
36631.W1225	M12	25	6.6	21.0	8	12.9	A2 s/s
36631.W1230	M12	30	6.6	21.0	8	12.9	A2 s/s
36631.W1240	M12	40	6.6	21.0	8	12.9	A2 s/s
36631.W1250	M12	50	6.6	21.0	8	12.9	A2 s/s
36631.W0406-A4	M 4	6	2.2	7.6	2.5	4.5	A4 s/s

SEALING SCREWS



36633

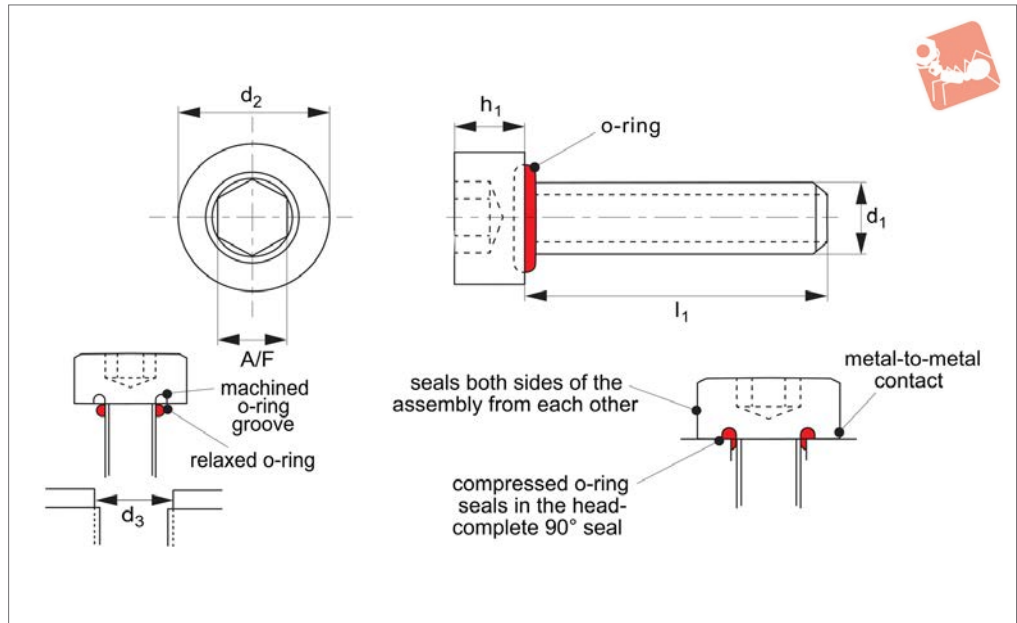

Material

Stainless steel (AISI 303 1.4305 tensile strength 550 N/mm² or AISI 316 1.440 tensile strength 480 N/mm²), with silicone „O” ring as standard.
 For other „O” ring materials see technical data pages (-FS = fluorosilicone, -EP = EPDM, -VI = viton, -NI = nitrile, -BN = Buna etc.).

Other thread lengths on request.

Technical Notes

Screws generally as DIN 912, seals substances in and contaminants out
 Re-useable, clearance holes recommended for maximum sealing.
 Max temperature range: -100°C to +260°C, pressure range - up to 410 bar (6000 psi).

Also available (on request) with thread-locking.

Tips

Clearance holes recommended for maximum sealing performance (see dimensions below).
 Clearance hole depth 2-3 x thread pitch, threads are metric coarse pitch.

Order No.	d ₁	l ₁	h ₁ max.	d ₂ max.	A/F	d ₃ ±0.05	Material
36633.W0306	M 3	6	3.0	5.5	2.5	3.6	A2 s/s
36633.W0308	M 3	8	3.0	5.5	2.5	3.6	A2 s/s
36633.W0310	M 3	10	3.0	5.5	2.5	3.6	A2 s/s
36633.W0312	M 3	12	3.0	5.5	2.5	3.6	A2 s/s
36633.W0320	M 3	20	3.0	5.5	2.5	3.6	A2 s/s
36633.W0406	M 4	6	4.0	7.0	3.0	4.5	A2 s/s
36633.W0408	M 4	8	4.0	7.0	3.0	4.5	A2 s/s
36633.W0410	M 4	10	4.0	7.0	3.0	4.5	A2 s/s
36633.W0412	M 4	12	4.0	7.0	3.0	4.5	A2 s/s
36633.W0416	M 4	16	4.0	7.0	3.0	4.5	A2 s/s
36633.W0420	M 4	20	4.0	7.0	3.0	4.5	A2 s/s
36633.W0508	M 5	8	5.0	8.5	4.0	5.6	A2 s/s
36633.W0510	M 5	10	5.0	8.5	4.0	5.6	A2 s/s
36633.W0512	M 5	12	5.0	8.5	4.0	5.6	A2 s/s
36633.W0516	M 5	16	5.0	8.5	4.0	5.6	A2 s/s
36633.W0520	M 5	20	5.0	8.5	4.0	5.6	A2 s/s
36633.W0612	M 6	12	6.0	10.0	5.0	6.8	A2 s/s
36633.W0616	M 6	16	6.0	10.0	5.0	6.8	A2 s/s
36633.W0620	M 6	20	6.0	10.0	5.0	6.8	A2 s/s
36633.W0625	M 6	25	6.0	10.0	5.0	6.8	A2 s/s
36633.W0630	M 6	30	6.0	10.0	5.0	6.8	A2 s/s
36633.W0812	M 8	12	8.0	13.0	6.0	8.5	A2 s/s
36633.W0816	M 8	16	8.0	13.0	6.0	8.5	A2 s/s
36633.W0820	M 8	20	8.0	13.0	6.0	8.5	A2 s/s
36633.W0825	M 8	25	8.0	13.0	6.0	8.5	A2 s/s
36633.W0830	M 8	30	8.0	13.0	6.0	8.5	A2 s/s
36633.W1016	M10	16	10.0	16.0	8.0	10.6	A2 s/s
36633.W1020	M10	20	10.0	16.0	8.0	10.6	A2 s/s



Cap Head Seal Screws

hex. socket



Sealing Screws

Order No.	d ₁	l ₁	h ₁ max.	d ₂ max.	A/F	d ₃ ±0.05	Material
36633.W1025	M10	25	10.0	16.0	8.0	10.6	A2 s/s
36633.W1030	M10	30	10.0	16.0	8.0	10.6	A2 s/s
36633.W1040	M10	40	10.0	16.0	8.0	10.6	A2 s/s
36633.W1220	M12	20	12.0	18.0	10.0	12.85	A2 s/s
36633.W1225	M12	25	12.0	18.0	10.0	12.85	A2 s/s
36633.W1230	M12	30	12.0	18.0	10.0	12.85	A2 s/s
36633.W1240	M12	40	12.0	18.0	10.0	12.85	A2 s/s
36633.W1250	M12	50	12.0	18.0	10.0	12.85	A2 s/s
36633.W0420-A4B	M 4	20	4.0	7.0	3.0	4.5	V1 s/s

SEALING SCREWS

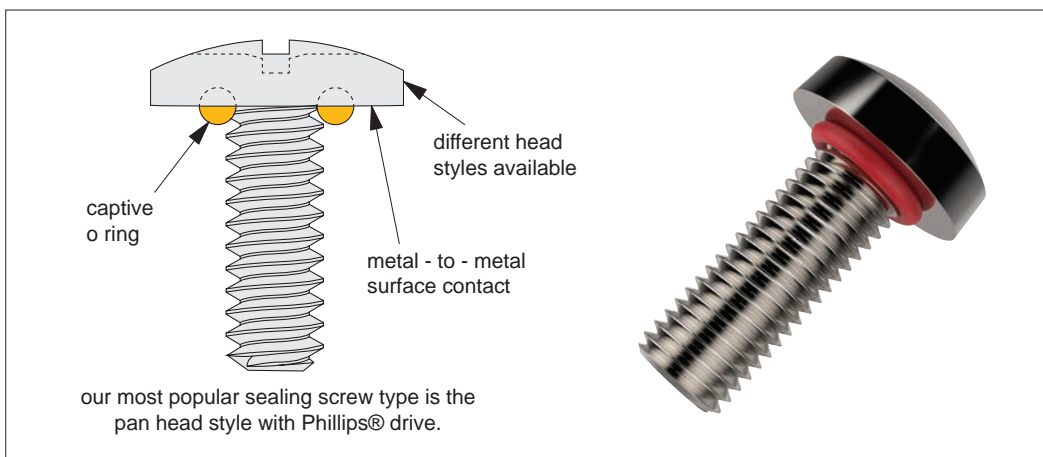

Why use Sealing Screws?

An ordinary screw lacks seal protection, allowing dirt, fluids, gases etc to infiltrate and damage sensitive devices. Sealing screws provide bi-directional sealing protection to systems where screws are used, to protect them against dirt, chemicals, water or other contaminants, which (without the screw seal), may penetrate and cause damage, or alternatively where gases and liquids may leak out.

Sealing screws are designed and manufactured with a precision engineered groove beneath the head of the fastener to accommodate the integral O-ring. As the fastener is tightened, the O-ring is compressed, squeezing it between the groove and mating surface to complete the seal. The design of the groove controls the amount of compression of the O-ring, and because O-rings retain their elastic memory, the screws are reusable time after time.

The seal provides bi-directional sealing which provides a total barrier seal against internal or external conditions (water, fluids, chemicals, dirt, air, contaminants etc) which could otherwise penetrate and damage systems. The screws are very easy to use and do not need any special preparation or re-tightening.

There are a range of O-ring materials that can resist virtually all chemical and environmental conditions. We can also provide sealing screws (on request) to military specifications (MILSPEC).

Sealing Screw Heads

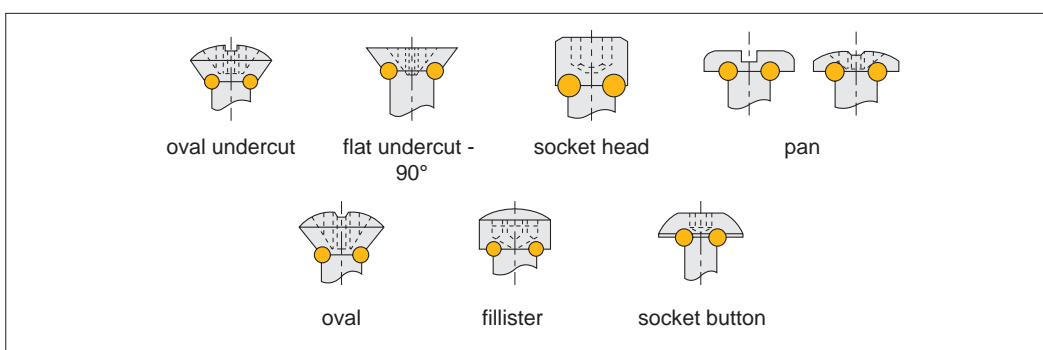

Ordering Options



36630 - Pan head - Phillips® Security and Torx® options

36631 - Button Hex-head Security and Torx® options

36633 - Socket Head Security and Torx® options

36636 - Hexagon Nut

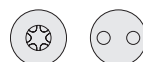



Optimal performance

When using self-sealing screws a high pressure seal is formed along the thread's contact surface when torqued.

If possible, and to ensure maximum sealing performance, we recommend a clearance hole (see table below), this creates room for the O-ring to flow into.

The aim is to ensure full metal-to-metal contact between the underside of the fastener and the mounting surface.

If a clearance hole cannot be utilized, the O-ring will still function as it will compress to fill the gap between the male and female surfaces.

We also have a range of sealing nuts to complement our range of sealing screws. These sealing nuts often eliminate the need for gaskets, compounds and surface preparation. They are widely used in the hydraulic, pneumatic or fuel systems industries.

They are invaluable when a vacuum needs to be created and provide a complete seal when gaseous or liquid pressure is a factor. Domed nuts are self-sealing and provide exceptional vibration resistance.

Some of the typical applications for our sealing screws include:

- Motors
- Cabinets and enclosures
- Sensors and instrumentation
- Internal combustion engines
- Gear pumps
- Fuel tanks
- Transmissions
- Gear boxes
- Air cylinders
- Pressure gauges
- Computer disk drives
- Motion control valves
- Missile tanks
- Wet wings

Self-sealing Screw

Applications

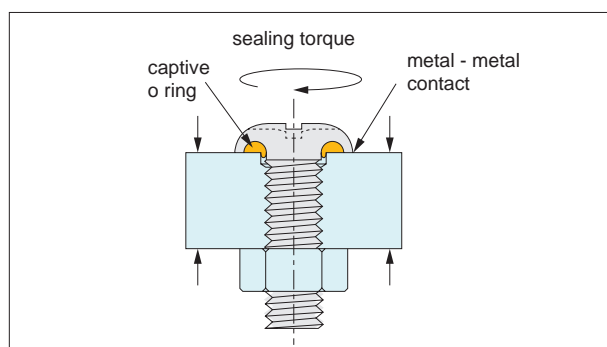

Thread Size	Standard Installation Torque
M3	0.6 Nm
M3.5	1.0 Nm
M4	2.2 Nm
M5	2.5 Nm
M6	8.5 Nm
M8	16 Nm
M10	30 Nm

Installation Torque

Nom. Size	Max clearance hole Ø
M2	2,44
M2,5	2,95
M3	3,45
M3,5	3,66
M4	4,55
M5	5,56
M6	6,66
M8	9,04
M10	11,05
M12	14,05
M14	16,05
M16	18,06

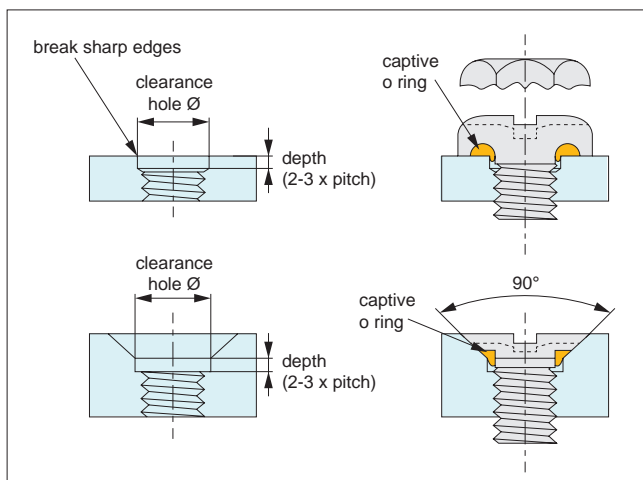



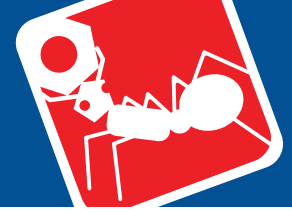

Clearance Hole Ø - Recommended

For optimal seal screw performance we recommend creating a clearance hole in the panel into which the O-ring can be fitted. This causes the O-ring to create a complete seal, and the clearance hole thus prevents extrusion into the metal when the screw is under pressure.

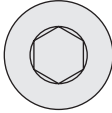

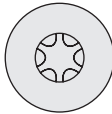
Drive Types

Schematic	Drive Types	Uses
	Hexagonal	Ideal for precision assembly. Most recommended where less surface area is available.
	Cross Drive (Phillips®)	Most recommended drive type. Provides good control in driving. Always use a driver bit of the proper size which is in good condition.
	Hexalobular (Torx®)	Positive-engaging, fast-locating method which transmits drive torque with less required downward pressure. Good fastening appearance.
	Security	These screws are impossible to remove without the special matching screwdriver.

We can provide Torx® heads and security/tamper-proof screws, as well as special threads, grooves and cross holes for safety wires, and a further range of styles such as captive screws, anti-vibration strips on the threads etc (for extreme vibration applications).

O ring Selection

Standard O rings are red silicone, but a further five O ring material types are readily available. The main factor to consider when selecting an O ring type is the environment in which it will be placed, and the temperature range it will be subjected to.

Material	Notes
Silicone (SI)	Our standard O ring type with a wide temperature range -60°C to +200°C. Resistant to moderate or oxidising chemical, but not generally oil or solvent resistant.
Fluorosilicone (FS)	Widely used in the automotive and aerospace industries as it has excellent resistance to fuel, oil and solvents. Standard temperature range -50°C to +170°C.
EPDM (EP)	These O rings are very suited for outdoor environments and are good for weather and water resistant applications having excellent ozone, steam and chemical resistance. Temperature range -50°C to +110°C.
Viton-fluorocarbon (VI)	These seals are widely used on aircraft engines and automotive fuel handling systems as they have excellent fuel, oil and solvent resistance. Standard temperature range -50°C to +200°C
Nitrile (NI)	Widely used as highly resistant to petroleum based substances, water and alcohols. Temperature range -50°C to +110°C.

Other O rings types can include Neoprene, Buna N, Teflon etc.



Our standard screw material is stainless steel (AISI 303, 1.4305). Other materials available are aluminium (non-magnetic and 1/3 weight of steel), brass (high electrical conductivity, non-magnetic and good corrosion resistance), titanium (low weight, very strong and highly corrosion resistant), stainless steel (A4, AISI 316).

Fasteners can be supplied to MILSPEC standards (MIL-S-82496A) on request.

Finishes are dependent on the material you are wishing to coat and subject to minimum quantities.

Materials

Finishes

Finish	Notes
Black Chrome (MIL-C-1458B)	Black chrome is a hard, non-reflective coating which is resistant to abrasion, heat and erosion. The black chrome surface is a dull, dark grey and may be waxed or oiled to darken surface.
Black Oxide Coating (MIL-C-13924B)	Black oxide is a uniform black coating for ferrous metals. Generally it is considered a decorative coating and provides only very limited corrosion protection under mild corrosion conditions.
Cadmium	Cadmium is a bright, silvery white plating. Supplementary treatments for Type II can be golden, iridescent, amber, black or olive drab.
Passivate (QQ-P-35/MIL S-500SC)	Passivation is a process designed to remove foreign metals from the surface of stainless and corrosion resistant steels.
Phosphate Coating Light (TT-C-00490B)	Phosphate coating is a light coating for use as a base paint.
Gold (MIL-G-45204B)	Yellow to orange colour depending on proprietary process used. Will range from matt to bright finish depending on base metal. Good corrosion resistance and high tarnish resistance.
Nickel (QQ-N-290A)	Nickel is a corrosion protective plating for steel, zinc and zinc alloys as well as copper and copper alloys.
Zinc (QQ-Z-325C)	The primary use of chromate finishes on zinc is to retard or prevent formation of white corrosion products on zinc surfaces.



Shoulder Screws

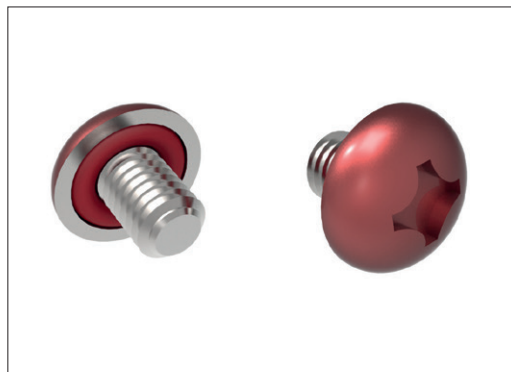

Painted Heads



Captive Screws



Security Heads (Tamper Proof)

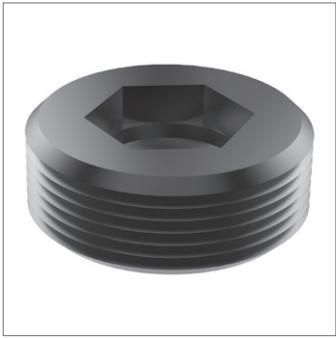

39200

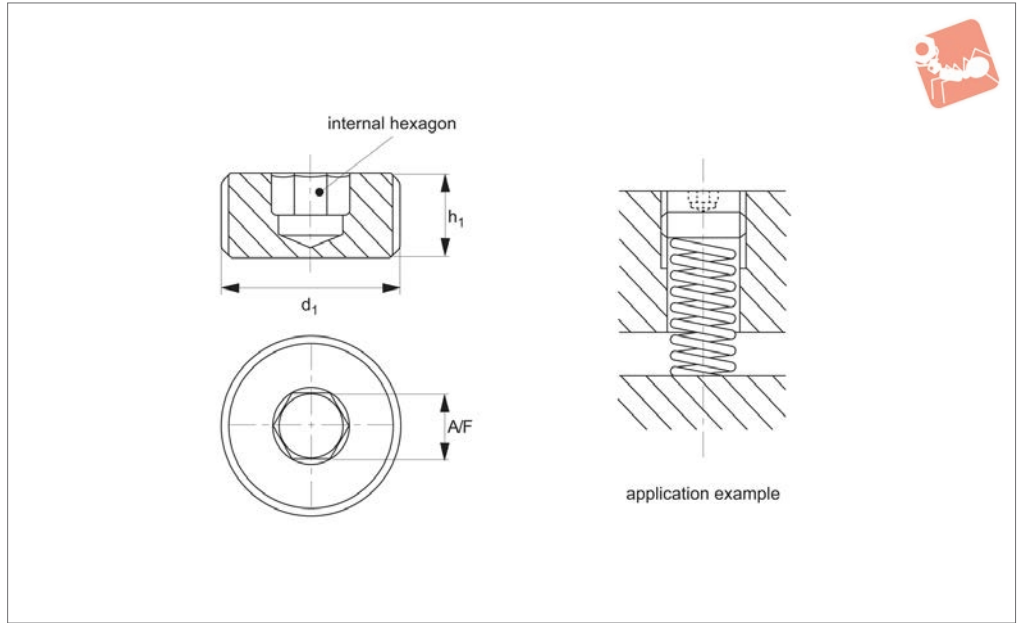

Material

Steel, blackened. Strength class 5.8, 500 N/mm²

Order No.	d ₁	h ₁	A/F
39200.W0012	M12x1,5	10	6
39200.W0016	M16x1,5	10	8
39200.W0020	M20x1,5	12	10
39200.W0024	M24x1,5	12	14
39200.W0027	M27x1,5	12	14
39200.W0030	M30x1,5	12	17
39200.W0033	M33x1,5	12	17



Integral Seal Hex. Nuts Stainless



Sealing Screws

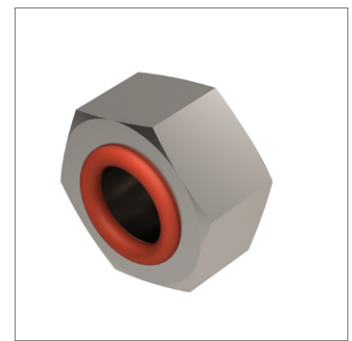
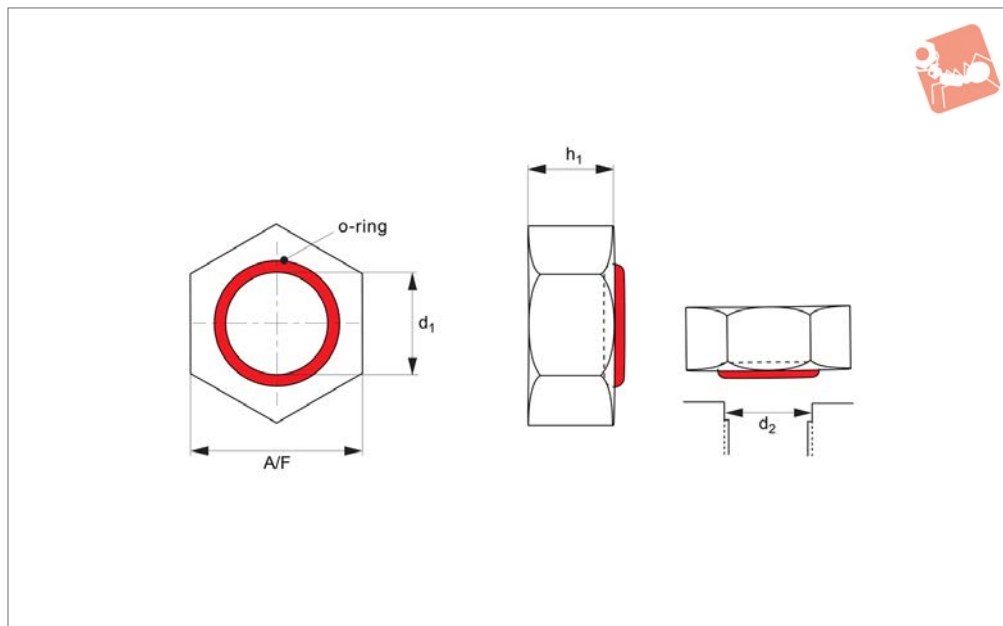

36636

SEALING SCREWS

Material

Stainless steel (AISI 303 1.4305 tensile strength 550 N/mm² or AISI 316 1.440 tensile strength 480 N/mm²), with silicone „O“ ring as standard.
For other „O“ ring materials see technical data pages,
(-FS = fluorosilicone, -EP = EPDM, -VI =

viton, -NI = nitrile, -BN = Buna etc.).

Technical Notes

Seals substances in and contaminants out, re-useable.
Max temperature range: -100°C to +260°C, pressure range - up to 410 bar (6000 psi).

Tips

Clearance holes recommended for maximum sealing performance (see dimensions below).
Clearance hole depth 2-3 x thread pitch, threads are metric coarse pitch.

Order No.	d ₁	A/F	d ₂ ±0.05	h ₁ max.	Material
36636.W0020	M 2	4	2.35	1.6	A2 s/s
36636.W0025	M2,5	5	2.75	2.0	A2 s/s
36636.W0030	M 3	5.5	3.6	2.4	A2 s/s
36636.W0040	M 4	7	4.5	3.2	A2 s/s
36636.W0050	M 5	8	5.6	4.7	A2 s/s
36636.W0060	M 6	10	6.8	5.2	A2 s/s
36636.W0080	M 8	13	8.5	6.8	A2 s/s
36636.W0100	M10	16	10.6	8.4	A2 s/s
36636.W0120	M12	18	12.85	10.8	A2 s/s
36636.W0140	M14	21	15.1	12.8	A2 s/s
36636.W0160	M16	24	17.5	14.8	A2 s/s

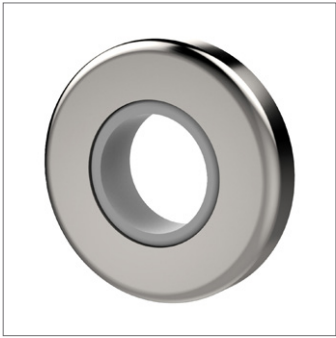

36637

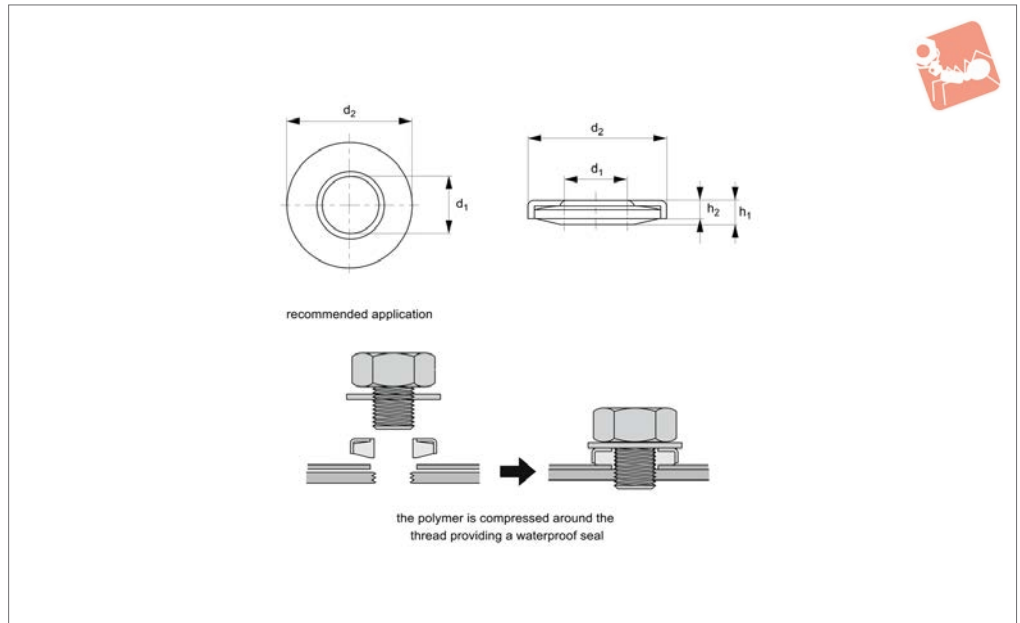

Material

Stainless steel (AISI 304, 1.4301), with thermoplastic elastomer (TPE) insert.

Technical Notes

Seals substances in and contaminants out. For watertight applications, the seal is best

placed against a smooth material, ensuring a tight seal is created.

Tips

We recommend installing a flat washer above the sealing washer to ensure that uniform pressure is applied to the elas-

tomer inside the washer. We recommend that you test the sealing washer in your application to determine the optimum tightening torque. For use at -30 °C to 90 °C.

Order No.	For thread	d ₁	d ₂	h ₁	h ₂	Recommended tightening torque Nm	Rated pressure (liquids) Bar max.	Rated pressure (gases) Bar max.	Weight g
36637.W0030	M 3	3.0	8	3.1	2.5	0,3-0,6	7	7	0.4
36637.W0040	M 4	4.1	10	3.5	3.0	0,8-1,5	7	7	0.6
36636.SP005	M 5	5.1	12	3.5	3.0	1,5-3,0	7	7	1.0
36637.W0060	M 6	6.1	14	3.5	3.0	2,5-5,0	7	7	1.0
36636.SP006	M 8	8.1	18	4.0	3.0	6,2-12	7	7	2.0
36637.W0100	M10	10.1	23	4.0	3.0	24-12	7	7	3.0
36637.W0120	M12	12.1	25	4.0	3.0	21-42	7	7	4.0
36637.W0160	M16	16.1	30	4.5	3.0	53-106	7	7	6.0
36637.W0200	M20	20.1	37	4.5	3.0	103 min.	7	7	9.0



Hygienic Nuts - Female

304 stainless steel



Sealing Screws

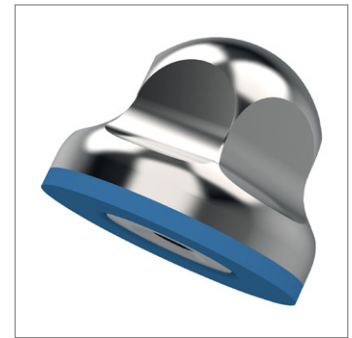
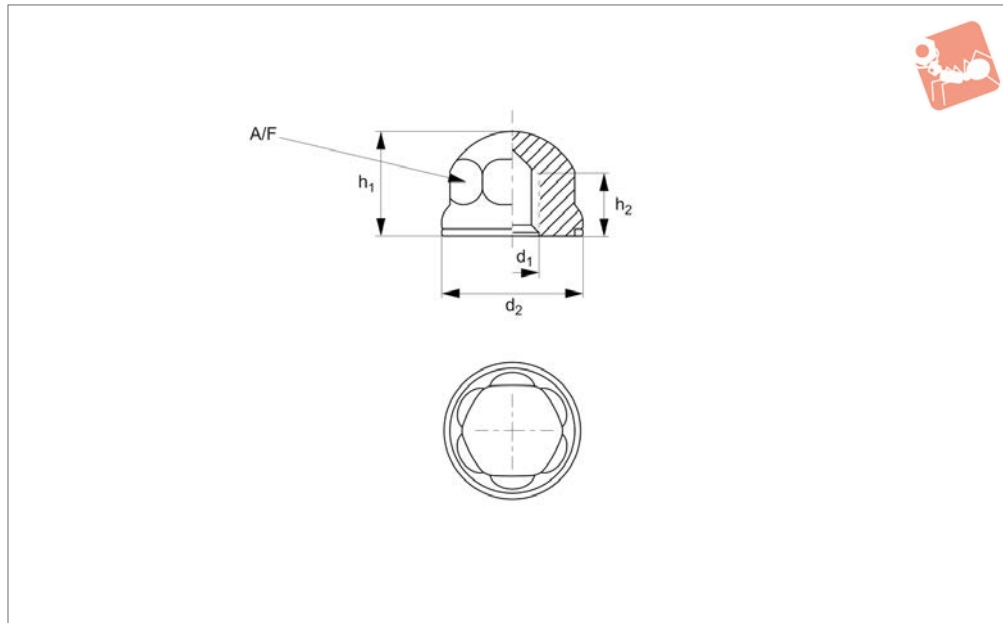

36638

SEALING SCREWS

Material

AISI 304 stainless steel high-gloss polished dome-nut, FDA blue silicone gasket, 3-A accepted. Available on request in AISI 316.

Technical Notes

For use in hygienic areas, components can be mounted without dead spaces. Sealing ring is hydrogenated acrylonitrile butadiene rubber (H-NBR), hardness 85±5

shore A, temp range -25°C to +150°C, blue.

Polished finish Ra < 0,8μ

Order No.	d ₁	d ₂	h ₁	h ₂	A/F
36638.W0003	M 3x0,5	15	12	8	HEX 10
36638.W0004	M 4x0,7	15	12	8	HEX 10
36638.W0005	M 5x0,8	19	17	12	HEX 14
36638.W0006	M 6x1	19	17	12	HEX 14
36638.W0008	M 8x1,25	24	23	15	HEX 17
36638.W0010	M10x1,5	24	23	15	HEX 17
36638.W0012	M12x1,75	24	23	15	HEX 17
36638.W0014	M14x2	30	28	20	HEX 22
36638.W0016	M16x2	30	28	20	HEX 22
36638.W0020	M20x2,5	35	34	25	HEX 27
36638.W0024	M24x3	42	40	30	HEX 32

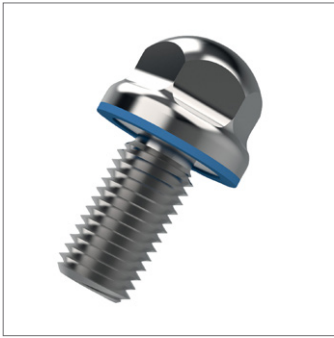

37370

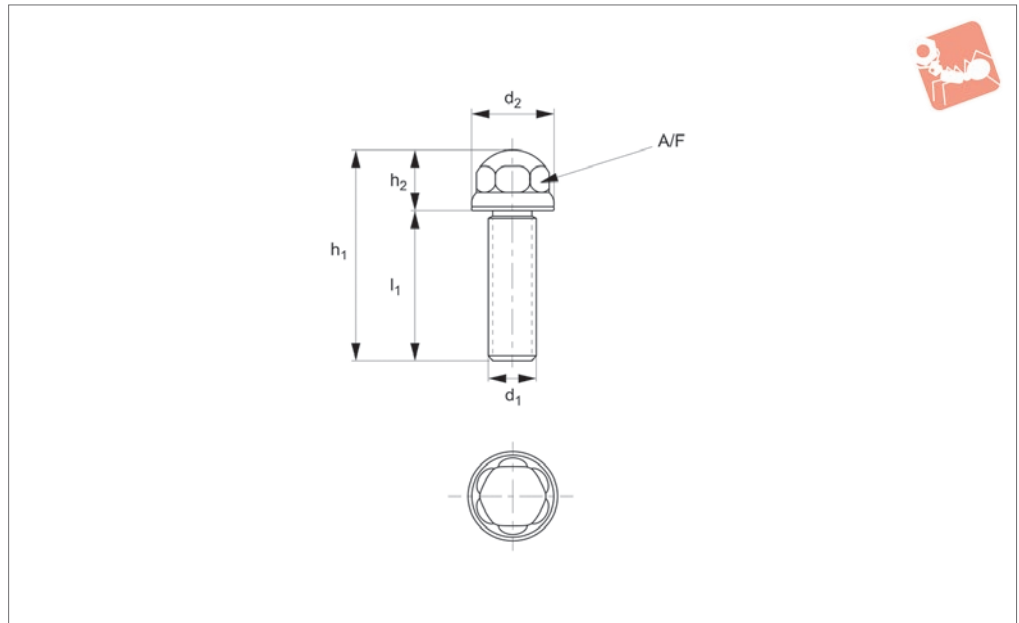

SEALING SCREWS

Material

Stainless steel (AISI 304) high-gloss polished dome-nut, FDA blue silicone gasket, 3-A accepted.

be mounted without dead spaces.

Sealing ring is hydrogenated acrylonitrile butadiene rubber (H-NBR), hardness 85±5 shore A, temp range -25°C to +150°C, blue.

Polished finish Ra < 0,8µ.

Technical Notes

For use in hygienic areas, components can

Order No.	d ₁	d ₂	h ₁	l ₁	h ₂	A/F
37370.W0510	M5x0,8	19	24	10	14	HEX 14
37370.W0516	M5x0,8	19	26	16	10	HEX 14
37370.W0520	M5x0,8	19	34	20	14	HEX 14
37370.W0612	M6x1	19	26	12	14	HEX 14
37370.W0616	M6x1	19	30	16	14	HEX 14
37370.W0620	M6x1	19	34	20	14	HEX 14
37370.W0625	M6x1	19	39	25	14	HEX 14
37370.W0630	M6x1	19	44	30	14	HEX 14
37370.W0816	M8x1,25	24	33	16	17	HEX 17
37370.W0820	M8x1,25	24	37	20	17	HEX 17
37370.W0825	M8x1,25	24	42	25	17	HEX 17
37370.W0830	M8x1,25	24	47	30	17	HEX 17
37370.W0840	M8x1,25	24	57	40	17	HEX 17
37370.W1020	M10x1,5	24	37	20	17	HEX 17
37370.W1025	M10x1,5	24	42	25	17	HEX 17
37370.W1030	M10x1,5	24	47	30	17	HEX 17
37370.W1040	M10x1,5	24	57	40	17	HEX 17
37370.W1050	M10x1,5	24	67	50	17	HEX 17
37370.W1220	M12x1,75	24	27	20	7	HEX 17
37370.W1225	M12x1,75	24	42	25	17	HEX 17
37370.W1230	M12x1,75	24	47	30	17	HEX 17
37370.W1240	M12x1,75	24	57	40	17	HEX 17
37370.W1250	M12x1,75	24	67	50	17	HEX 17
37370.W1630	M16x2	30	52	30	22	HEX 22
37370.W1640	M16x2	30	62	40	22	HEX 22
37370.W1650	M16x2	30	72	50	22	HEX 22
37370.W1660	M16x2	30	82	60	22	HEX 22
37370.W1670	M16x2	30	92	70	22	HEX 22
37370.W1680	M16x2	30	102	80	22	HEX 22
37370.W2030	M20x2,5	35	56	30	26	HEX 27
37370.W2040	M20x2,5	35	66	40	26	HEX 27
37370.W2050	M20x2,5	35	76	50	26	HEX 27



Hygienic Screws - Male

304 stainless steel



Sealing Screws

Order No.	d ₁	d ₂	h ₁	l ₁	h ₂	A/F
37370.W2060	M20x2,5	35	86	60	26	HEX 27
37370.W2070	M20x2,5	35	96	70	26	HEX 27
37370.W2080	M20x2,5	35	106	80	26	HEX 27

SEALING SCREWS



39000

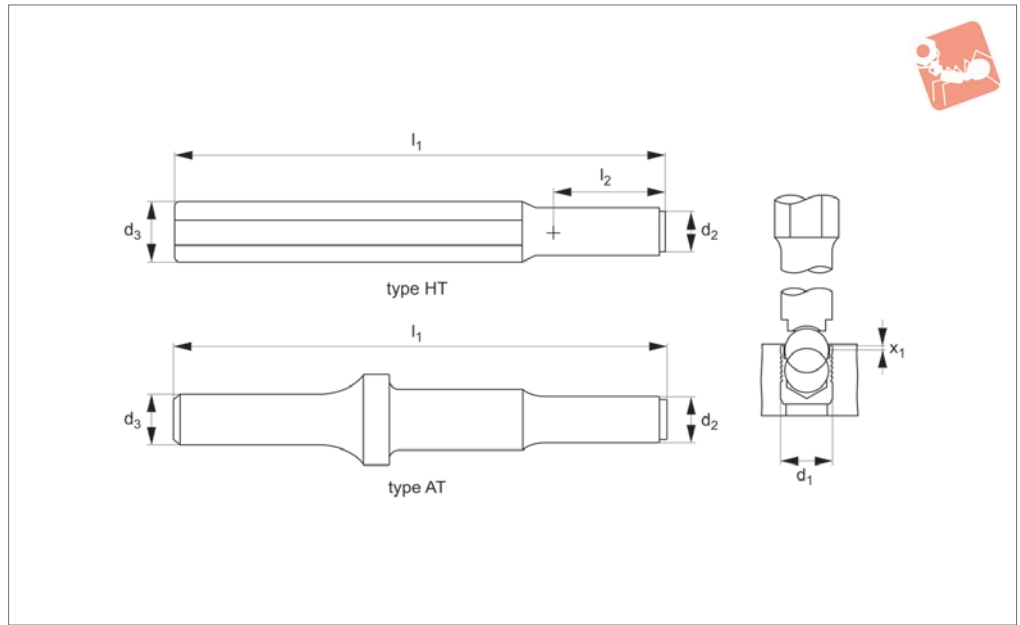

Material

Tool steel, heat-treated.

Technical Notes

Please consult technical pages for installa-

tion instructions and performance data.

Hand tool version and air tool (for multiple installations).

Ensure the ball is fully seated before

applying pressure.

Tips

Metric dimensions in mm.

Inch dimensions in inches.

Order No.	d ₁	d ₂	d ₃	l ₁	l ₂	x ±0.2	Type
39008.W1030	3.0	2.8	9.53	127	10	0.4	Hand
39008.W1040	4.0	3.8	9.53	127	10	0.2	Hand
39008.W1070	7.0	6.8	9.53	127	18	0.4	Hand
39008.W1080	8.0	7.8	9.53	127	20	0.3	Hand



Expansion Sealing Plugs

Metric - standard



Sealing Screws

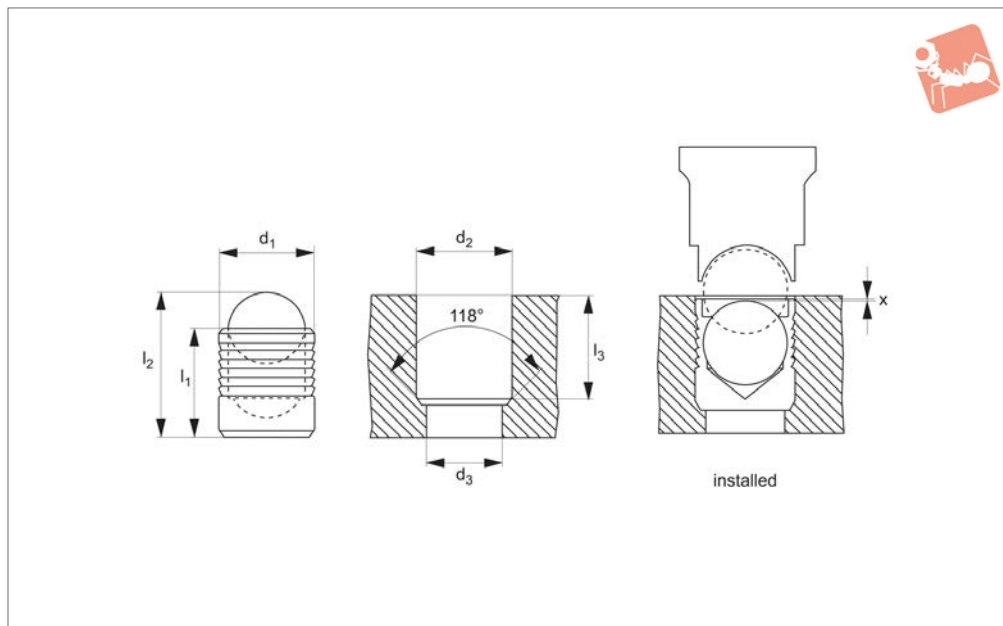

39001

SEALING SCREWS

Material

Plug body: case hardened steel (zinc-plated), stainless steel (A2, AISI 303 & A4 AISI 316) or aluminium (2024-T4).

Ball: heat-treated bearing steel or stainless steel (A2, AISI 303 & A4 AISI 316).

Technical Notes

These high pressure sealing plugs are used to blank off externally drilled holes for air

and gas.

No need for tapping, reaming, machining of O-ring grooves or the use of tapes or sealants.

Ensure the ball is fully seated before applying pressure.

Tips

Working pressure up to 450 bar (dependent on body material and material into which

installed).

Please consult technical pages for installation instructions and performance data.

Important Notes

Please refer to technical pages for product installation details.

Order No.	d ₁	l ₁	l ₂	d ₂ +0.1 -0.0	d ₃ max.	l ₃ min.	x ±0.2	Body	Ball
39001.W1040	4.0	4.0	5.2	4.0	3.3	3.8	0.2	Steel ZP	Steel
39001.W1050	5.0	5.5	7.1	5.0	4.3	5.3	0.4	Steel ZP	Steel
39001.W1060	6.0	6.5	8.7	6.0	5.3	6.3	0.4	Steel ZP	Steel
39001.W1070	7.0	7.5	10.2	7.0	6.4	7.3	0.4	Steel ZP	Steel
39001.W1080	8.0	8.5	11.6	8.0	7.4	8.3	0.3	Steel ZP	Steel
39001.W1100	10.0	11.0	15.2	10.0	9.4	10.8	0.4	Steel ZP	Steel
39001.W1160	16.0	17.0	23.4	16.0	14.7	16.5	0.6	Steel ZP	Steel
39001.W2030	3.0	3.6	4.6	3.0	2.2	3.4	0.4	A2 s/s	Steel
39001.W2040	4.0	4.0	5.2	4.0	3.3	3.8	0.2	A2 s/s	Steel
39001.W2050	5.0	5.5	7.1	5.0	4.3	5.3	0.4	A2 s/s	Steel
39001.W2060	6.0	6.5	8.7	6.0	5.3	6.3	0.4	A2 s/s	Steel
39001.W2120	12.0	13.0	17.9	12.0	10.6	12.8	0.4	A2 s/s	Steel
39001.W2160	16.0	17.0	23.4	16.0	14.7	16.5	0.6	A2 s/s	Steel
39001.W5030	3.0	3.6	4.6	3.0	2.2	3.4	0.4	Aluminium	A2 s/s
39001.W5050	5.0	5.5	7.1	5.0	4.3	5.3	0.4	Aluminium	A2 s/s
39001.W3030	3.0	3.6	4.6	3.0	2.2	3.4	0.4	A2 s/s	A2 s/s
39001.W3040	4.0	4.0	5.2	4.0	3.3	3.8	0.2	A2 s/s	A2 s/s
39001.W3050	5.0	5.5	7.1	5.0	4.3	5.3	0.4	A2 s/s	A2 s/s
39001.W3060	6.0	6.5	8.7	6.0	5.3	6.3	0.4	A2 s/s	A2 s/s
39001.W3080	8.0	8.5	11.6	8.0	7.4	8.3	0.3	A2 s/s	A2 s/s
39001.W3140	14.0	15.0	20.6	14.0	12.7	14.5	0.4	A2 s/s	A2 s/s
39001.W3160	16.0	17.0	23.4	16.0	14.7	16.5	0.6	A2 s/s	A2 s/s



39100

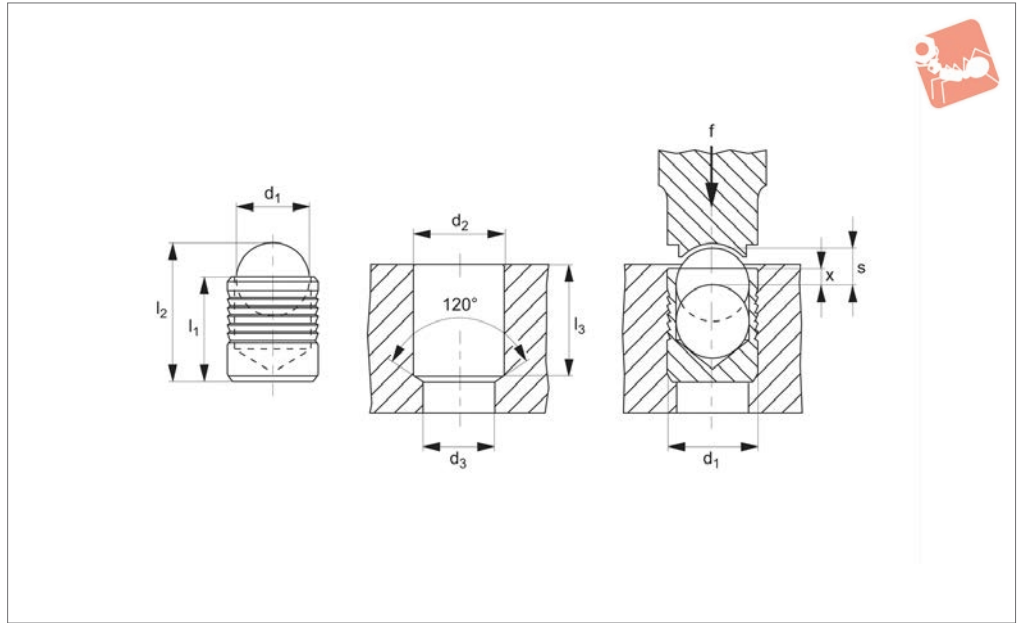

Material

Body: stainless steel 1,4305 (AISI 303).
Ball: roller bearing steel, heat-treated, tempered.

quick and economic sealing of bore holes in fluid technology, e.g. hydraulic drilling holes in jig and fixtures. Setting dies are required for assembly.

anical pages.

Technical Notes

Expander sealing plugs are used for safe,

Tips

For assembly instructions please see tech-

Order No.	d ₁	l ₁	l ₂ ≈	d ₂ +0.1	d ₃ max.	l ₃ min.	x ±0.2	s	Weight g
39100.W0053	3	3.6	4.6	3	2.2	3.4	0.4	1.20	0.1
39100.W0054	4	4.0	5.2	4	3.3	3.8	0.2	1.50	0.3
39100.W0055	5	5.5	7.0	5	4.3	5.3	0.4	2.00	0.7
39100.W0056	6	6.5	8.6	6	5.3	6.3	0.4	2.50	1.3
39100.W0057	7	7.5	10.1	7	6.4	7.3	0.4	3.00	2.4
39100.W0058	8	8.5	11.7	8	7.4	8.3	0.3	3.50	3.2
39100.W0059	9	10.0	13.7	9	8.4	9.8	0.4	4.00	4.5
39100.W0060	10	11.0	15.2	10	9.4	10.8	0.4	4.50	6.1
39100.W0062	12	13.0	18.0	12	10.6	12.8	0.4	5.50	9.7
39100.W0064	14	15.0	20.8	14	12.7	14.5	0.4	6.35	15.0
39100.W0066	16	17.0	23.7	16	14.7	16.5	0.6	7.00	22.0
39100.W0068	18	19.0	26.3	18	16.7	18.5	0.6	8.00	31.0
39100.W0070	20	22.0	30.5	20	18.7	21.5	0.8	9.00	46.0
39100.W0072	22	25.0	34.2	22	20.7	24.5	0.8	10.00	58.0



Expander[®] Sealing Plugs

stainless steel body



Sealing Screws

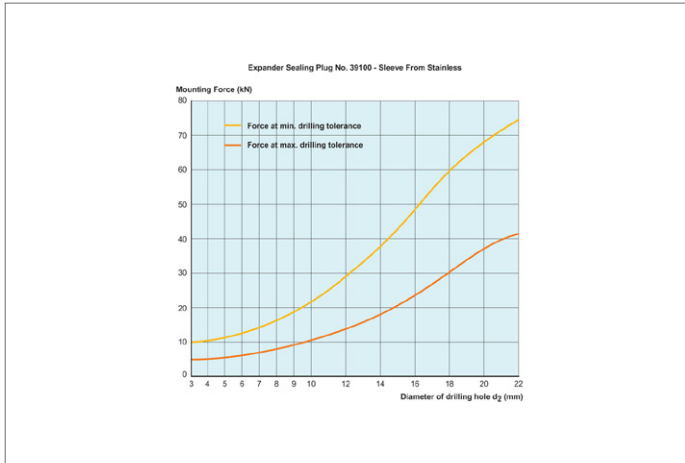



70000

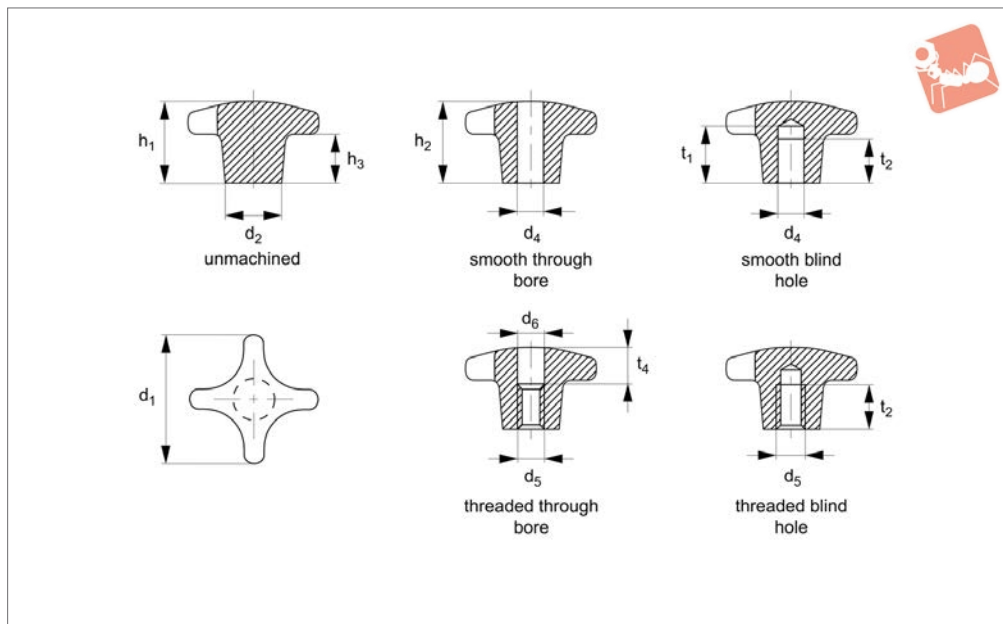

Material

Cast iron GG20, bright.

Technical Notes

Sandblasted or tumbled.

Tips

Grips with different bores or surface treatment can be made to order (min. quantity for specials 200 off).

Order No.	Finish	d ₁	d ₂	d ₄ tol. H7	d ₅	d ₆	h ₁	h ₂	h ₃	t ₁	t ₂	t ₄	Weight g
70000.W0032	Unmachined	32	12	-	-	-	21	-	10	-	-	-	38
70000.W0040	Unmachined	40	14	-	-	-	26	-	14	-	-	-	69
70000.W0050	Unmachined	50	18	-	-	-	34	-	20	-	-	-	115
70000.W0063	Unmachined	63	20	-	-	-	42	-	25	-	-	-	228
70000.W0080	Unmachined	80	25	-	-	-	52	-	30	-	-	-	415
70000.W0090	Unmachined	100	32	-	-	-	65	-	38	-	-	-	855
70000.W0132	Smooth, Through	32	12	6	-	-	-	20	-	-	-	-	34
70000.W0140	Smooth, Through	40	14	8	-	-	-	25	-	-	-	-	59
70000.W0150	Smooth, Through	50	18	10	-	-	-	32	-	-	-	-	95
70000.W0163	Smooth, Through	63	20	12	-	-	-	40	-	-	-	-	171
70000.W0180	Smooth, Through	80	25	16	-	-	-	50	-	-	-	-	338
70000.W0190	Smooth, Through	100	32	20	-	-	-	63	-	-	-	-	709
70000.W0232	Smooth, Blind	32	12	6	-	-	-	20	-	15	12	-	36
70000.W0240	Smooth, Blind	40	14	8	-	-	-	25	-	18	15	-	61
70000.W0250	Smooth, Blind	50	18	10	-	-	-	32	-	21	18	-	99
70000.W0263	Smooth, Blind	63	20	12	-	-	-	40	-	25	22	-	200
70000.W0280	Smooth, Blind	80	25	16	-	-	-	50	-	32	28	-	380
70000.W0290	Smooth, Blind	100	32	20	-	-	-	63	-	40	36	-	648
70000.W0332	Threaded, Through	32	12	-	M_6	6.4	-	20	-	-	-	10	34
70000.W0340	Threaded, Through	40	14	-	M_8	8.4	-	25	-	-	-	12	60
70000.W0350	Threaded, Through	50	18	-	M10	10.5	-	32	-	-	-	16	95
70000.W0363	Threaded, Through	63	20	-	M12	13.0	-	40	-	-	-	20	191
70000.W0380	Threaded, Through	80	25	-	M16	17.0	-	50	-	-	-	30	339
70000.W0390	Threaded, Through	100	32	-	M20	21.0	-	63	-	-	-	38	704
70000.W0432	Threaded, Blind	32	12	-	M_6	-	-	20	-	-	12	-	35
70000.W0440	Threaded, Blind	40	14	-	M_8	-	-	25	-	-	15	-	63
70000.W0450	Threaded, Blind	50	18	-	M10	-	-	32	-	-	18	-	103
70000.W0463	Threaded, Blind	63	20	-	M12	-	-	40	-	-	22	-	205
70000.W0480	Threaded, Blind	80	25	-	M16	-	-	50	-	-	28	-	359
70000.W0490	Threaded, Blind	100	32	-	M20	-	-	63	-	-	36	-	720



Palm Grips

cast iron - plastic coated

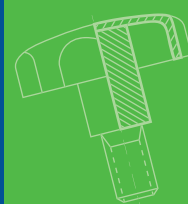

Grips

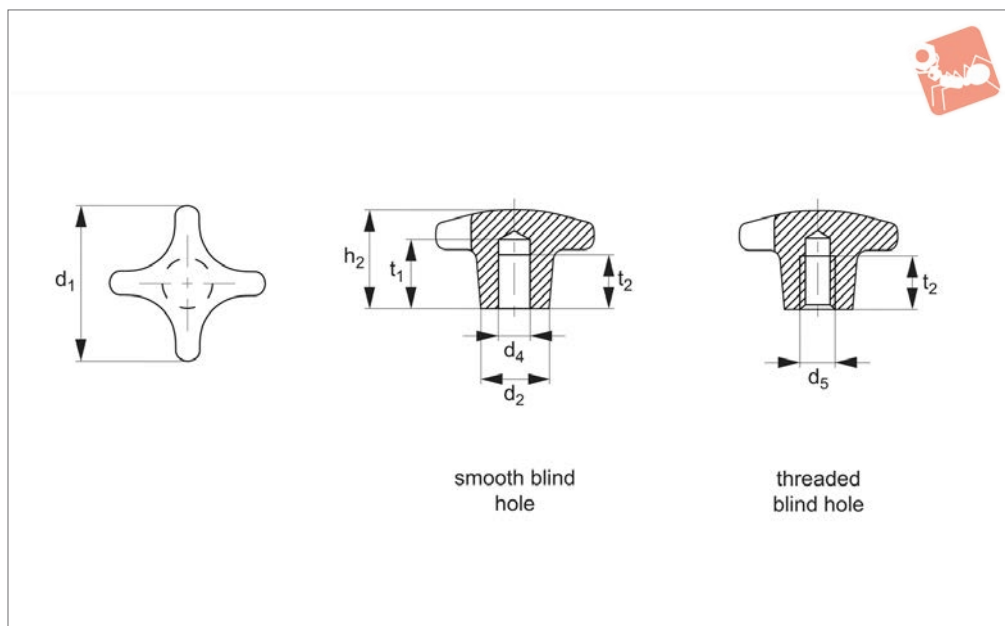

70020

GRIPS

Material

Cast iron GG20, plastic-coated, orange RAL2004 or black RAL9005 dull finish.

Technical Notes

Produced to DIN 6335.

Order No.	Finish	Colour	d ₁	d ₂	d ₄ tol. H7	d ₅	h ₂	t ₁	t ₂	Weight g
70020.W0540	Smooth, Blind	Orange	40	14	8	-	25	18	15	62
70020.W0550	Smooth, Blind	Orange	50	18	10	-	32	21	18	106
70020.W0563	Smooth, Blind	Orange	63	20	12	-	40	25	22	201
70020.W0580	Smooth, Blind	Orange	80	25	16	-	50	32	28	353
70020.W0640	Smooth, Blind	Black	40	14	8	-	25	18	15	62
70020.W0650	Smooth, Blind	Black	50	18	10	-	32	21	18	106
70020.W0663	Smooth, Blind	Black	63	20	12	-	40	25	22	201
70020.W0680	Smooth, Blind	Black	80	25	16	-	50	32	28	353
70020.W0541	Threaded, Blind	Orange	40	14	-	M 8	25	-	15	56
70020.W0551	Threaded, Blind	Orange	50	18	-	M10	32	-	18	110
70020.W0564	Threaded, Blind	Orange	63	20	-	M12	40	-	22	198
70020.W0581	Threaded, Blind	Orange	80	25	-	M16	50	-	28	364
70020.W0641	Threaded, Blind	Black	40	14	-	M 8	25	-	15	56
70020.W0651	Threaded, Blind	Black	50	18	-	M10	32	-	18	110
70020.W0664	Threaded, Blind	Black	63	20	-	M12	40	-	22	198
70020.W0681	Threaded, Blind	Black	80	25	-	M16	50	-	28	364



70040

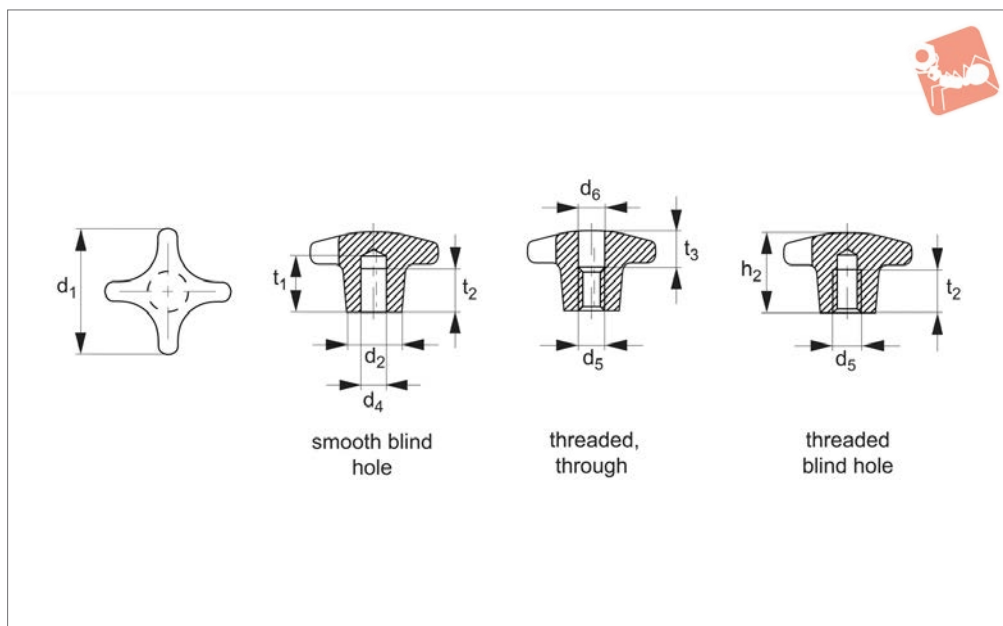

Material

Light metal aluminium (polished or unpolished).

Technical Notes

Produced to DIN 6335.

Tips

Grips with different bores or surface treatment can be made to order (min. quantity for specials 200 off).

Order No.	Finish	Type	d ₁	d ₂	d ₄ tol. H7	d ₅	d ₆	h ₂	t ₁	t ₂	t ₃	Weight g
70040.W0240	Unpolished	Smooth, Blind	40	14	8	-	-	25	18	15	-	25
70040.W0250	Unpolished	Smooth, Blind	50	18	10	-	-	32	21	18	-	45
70040.W0263	Unpolished	Smooth, Blind	63	20	12	-	-	40	25	22	-	84
70040.W0280	Unpolished	Smooth, Blind	80	25	16	-	-	50	32	28	-	141
70040.W0440	Unpolished	Threaded, Blind	40	14	-	M 8	-	25	-	15	-	22
70040.W0450	Unpolished	Threaded, Blind	50	18	-	M10	-	32	-	18	-	46
70040.W0463	Unpolished	Threaded, Blind	63	20	-	M12	-	40	-	22	-	86
70040.W0480	Unpolished	Threaded, Blind	80	25	-	M16	-	50	-	28	-	143
70040.W0640	Polished	Smooth, Blind	40	14	8	-	-	25	18	15	-	25
70040.W0650	Polished	Smooth, Blind	50	18	10	-	-	32	21	18	-	45
70040.W0663	Polished	Smooth, Blind	63	20	12	-	-	40	25	22	-	84
70040.W0680	Polished	Smooth, Blind	80	25	16	-	-	50	32	28	-	141
70040.W0840	Polished	Threaded, Blind	40	14	-	M 8	-	25	-	15	-	22
70040.W0850	Polished	Threaded, Blind	50	18	-	M10	-	32	-	18	-	46
70040.W0863	Polished	Threaded, Blind	63	20	-	M12	-	40	-	22	-	86
70040.W0880	Polished	Threaded, Blind	80	25	-	M16	-	50	-	28	-	143
70040.W0340	Unpolished	Threaded, Through	40	14	-	M 8	8.4	25	-	-	12	23
70040.W0350	Unpolished	Threaded, Through	50	18	-	M10	10.5	32	-	-	16	44
70040.W0363	Unpolished	Threaded, Through	63	20	-	M12	13.0	40	-	-	20	70
70040.W0380	Unpolished	Threaded, Through	80	25	-	M16	17.0	50	-	-	30	129
70040.W0740	Polished	Threaded, Through	40	14	-	M 8	8.4	25	-	-	12	23
70040.W0750	Polished	Threaded, Through	50	18	-	M10	10.5	32	-	-	16	44
70040.W0763	Polished	Threaded, Through	63	20	-	M12	13.0	40	-	-	20	70
70040.W0780	Polished	Threaded, Through	80	25	-	M16	17.0	50	-	-	30	129



Palm Grips

die-cast stainless steel - DIN 6335

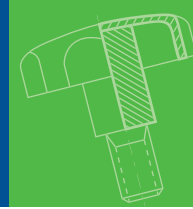

Grips

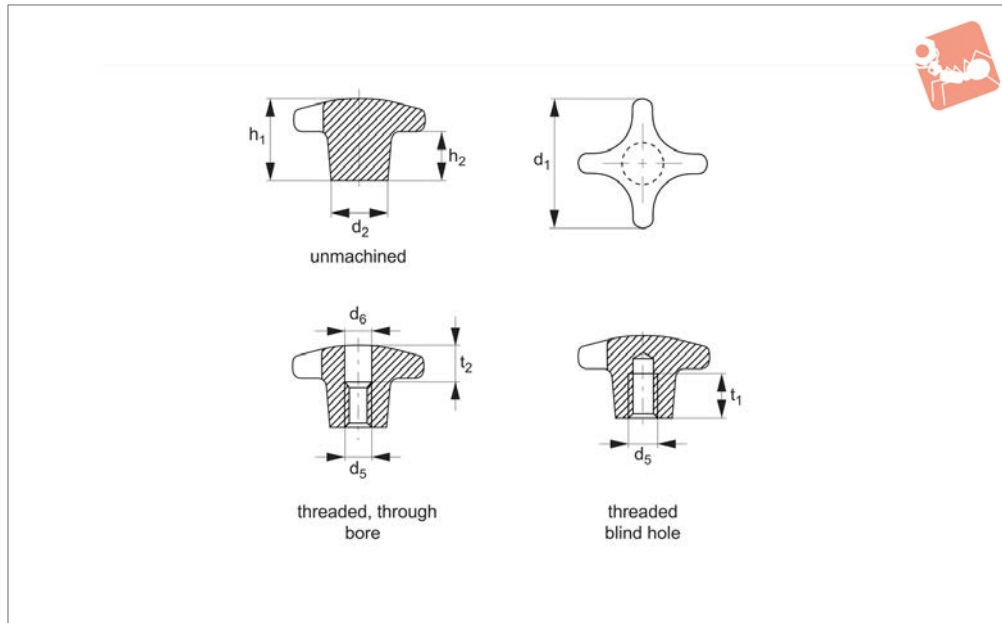

70042

GRIPS

Material

Stainless steel A2 (AISI 304), dull blasted.

Order No.	Finish	d_1	d_2	d_5	d_6	h_1	h_2	t_1	t_2	Weight g
70042.W0032	Unmachined	32	12	-	-	21	10	-	-	41
70042.W0040	Unmachined	40	14	-	-	26	14	-	-	70
70042.W0050	Unmachined	50	18	-	-	34	20	-	-	128
70042.W0063	Unmachined	63	20	-	-	42	25	-	-	227
70042.W0332	Threaded, Through	32	12	M 6	6.4	20	-	-	10	36
70042.W0340	Threaded, Through	40	14	M 8	8.4	25	-	-	12	60
70042.W0350	Threaded, Through	50	18	M10	10.5	32	-	-	16	107
70042.W0363	Threaded, Through	63	20	M12	13.0	40	-	-	20	192
70042.W0432	Threaded, Blind	32	12	M 6	-	20	-	12	-	38
70042.W0440	Threaded, Blind	40	14	M 8	-	25	-	15	-	62
70042.W0450	Threaded, Blind	50	18	M10	-	32	-	18	-	114
70042.W0463	Threaded, Blind	63	20	M12	-	40	-	22	-	205

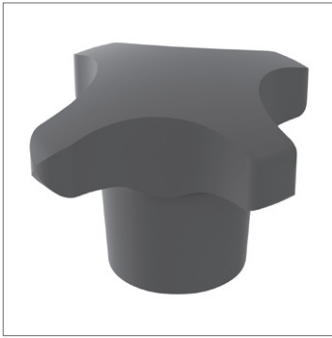

70060

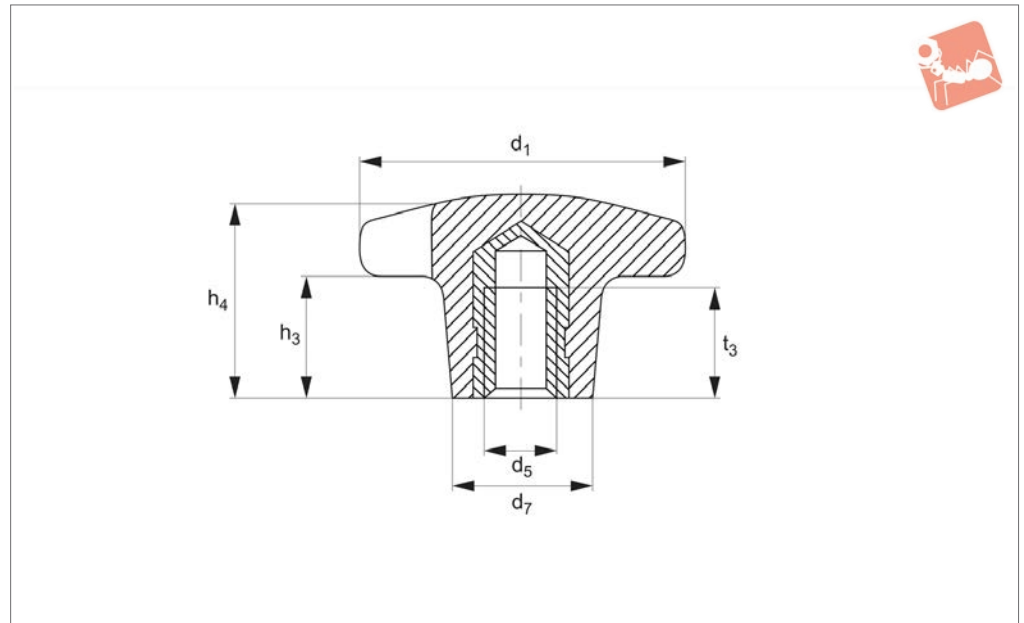

Material

Grip: duroplast PF 31 DIN 7708, black.

Threaded bush: steel, galvanised or stain-

less steel A2.

Temperature range: max 110°C.

Order No.	Finish	d_1	d_5	d_7	h_3	h_4	t_3	Weight g
70060.W0220	Brass	20	M_4	10	6	13	6.5	3.3
70060.W0225	Steel	25	M_5	12	8	16	9.5	7.0
70060.W0232	Steel	32	M_6	14	10	20	12.0	12.0
70060.W0240	Steel	40	M_8	18	13	25	14.0	16.0
70060.W0250	Steel	50	M10	22	20	32	18.0	32.0
70060.W0263	Steel	63	M12	26	25	40	22.0	62.0
70060.W0280	Steel	80	M16	35	30	50	30.0	137.0
70060.W1225	Stainless	25	M_5	12	8	16	9.5	7.0
70060.W1232	Stainless	32	M_6	14	10	20	12.0	12.0
70060.W1240	Stainless	40	M_8	18	13	25	14.0	16.0
70060.W1263	Stainless	63	M12	26	25	40	22.0	62.0
70060.W1280	Stainless	80	M16	35	30	50	30.0	137.0



Palm Grips with grub screw

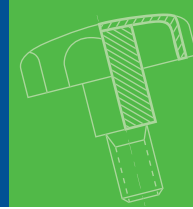

Grips

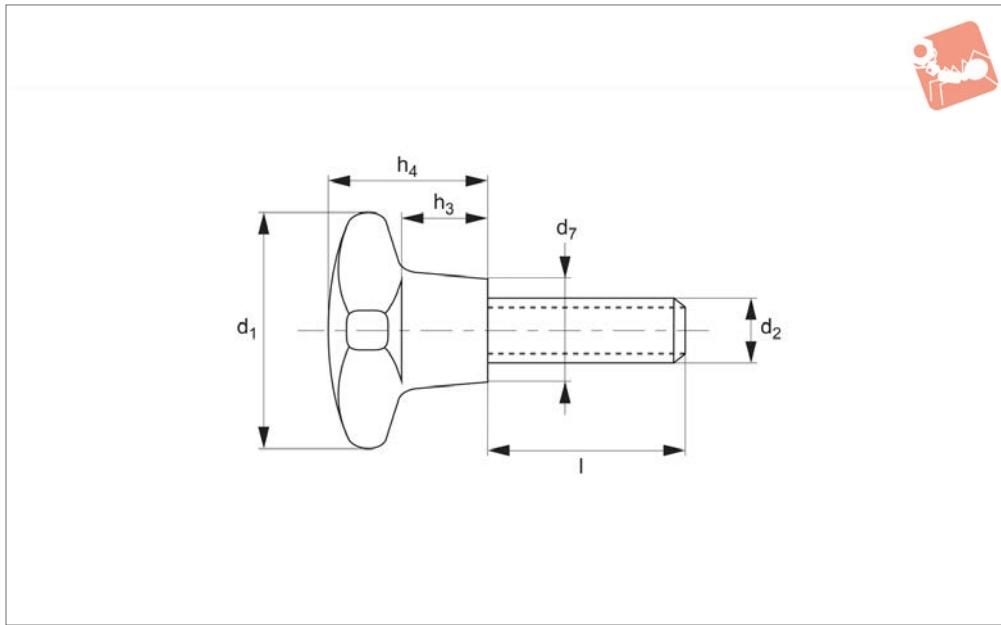

70080

GRIPS

Material

Duroplast PF 31, black.

Grub screw: steel, galvanised or stainless steel A2.

Technical Notes

Produced to DIN 7708.

Special designs e.g. different lengths or grub screws in brass, or stainless steel can

be made to order depending on quantity.
Temperature range up to 110°C.

Order No.	Material	d ₁	d ₂	d ₇	h ₃	h ₄	l ₁	Weight g
70080.W0051	Steel	25	M 5	12	8	16	10	6.7
70080.W0052	Steel	25	M 5	12	8	16	15	7.3
70080.W0053	Steel	25	M 5	12	8	16	20	7.5
70080.W0054	Steel	25	M 5	12	8	16	25	8.1
70080.W0055	Steel	25	M 5	12	8	16	30	8.9
70080.W0061	Steel	32	M 6	14	10	20	15	11.0
70080.W0062	Steel	32	M 6	14	10	20	20	12.0
70080.W0063	Steel	32	M 6	14	10	20	25	15.0
70080.W0064	Steel	32	M 6	14	10	20	30	16.0
70080.W0065	Steel	32	M 6	14	10	20	40	16.0
70080.W0081	Steel	40	M 8	18	13	25	20	24.0
70080.W0082	Steel	40	M 8	18	13	25	25	25.0
70080.W0083	Steel	40	M 8	18	13	25	30	26.0
70080.W0084	Steel	40	M 8	18	13	25	40	30.0
70080.W0085	Steel	40	M 8	18	13	25	50	32.0
70080.W0101	Steel	50	M10	22	20	32	25	41.0
70080.W0102	Steel	50	M10	22	20	32	30	48.0
70080.W0103	Steel	50	M10	22	20	32	40	51.0
70080.W0104	Steel	50	M10	22	20	32	50	56.0
70080.W0105	Steel	50	M10	22	20	32	60	69.0
70080.W0121	Steel	63	M12	26	25	40	30	86.0
70080.W0122	Steel	63	M12	26	25	40	40	93.0
70080.W0123	Steel	63	M12	26	25	40	50	99.0
70080.W0124	Steel	63	M12	26	25	40	60	105.0
70080.W0125	Steel	63	M12	26	25	40	80	112.0
70080.W0161	Steel	80	M16	35	30	50	40	198.0
70080.W0162	Steel	80	M16	35	30	50	50	175.0
70080.W0163	Steel	80	M16	35	30	50	60	219.0
70080.W0164	Steel	80	M16	35	30	50	80	251.0



70100

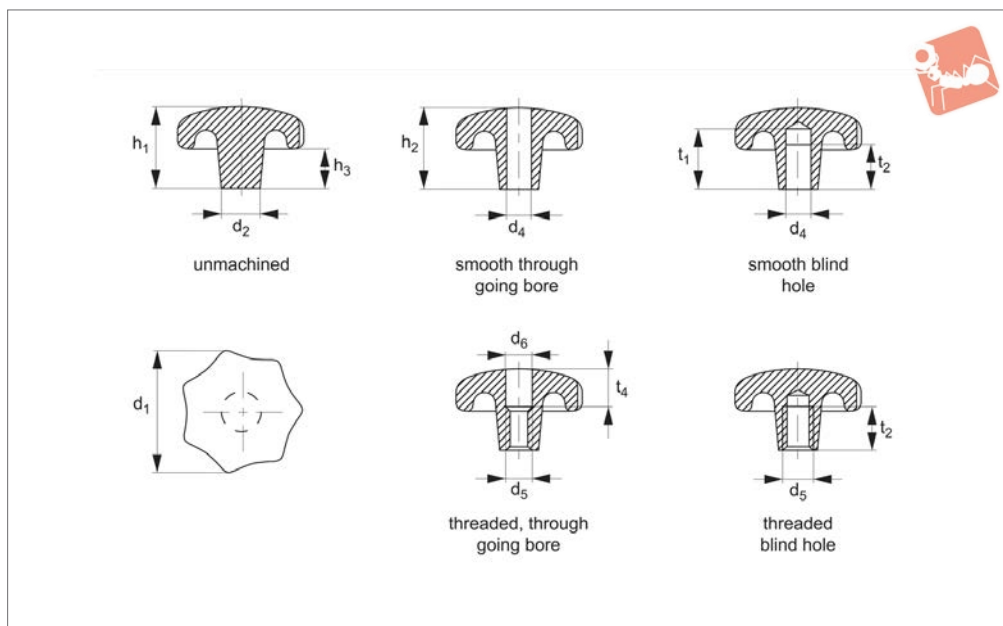

Material

GG20 cast iron, bright, sand blasted or tumbled.

Technical Notes

Grips with different bores or surface treatments can be obtained by special order,

(minimum quantity 200 off).

Order No.	Finish	d ₁	d ₂	d ₄ tol. H7	d ₅	d ₆	h ₁	h ₂	h ₃	t ₁	t ₂	t ₄	Weight g
70100.W0032	Unmachined	32	12	-	-	-	21	-	10	-	-	-	55
70100.W0040	Unmachined	40	14	-	-	-	26	-	13	-	-	-	82
70100.W0050	Unmachined	50	18	-	-	-	34	-	17	-	-	-	150
70100.W0063	Unmachined	63	20	-	-	-	42	-	21	-	-	-	260
70100.W0080	Unmachined	80	25	-	-	-	52	-	25	-	-	-	510
70100.W0132	Smooth, Through	32	12	6	-	-	-	20	-	-	-	-	49
70100.W0140	Smooth, Through	40	14	8	-	-	-	25	-	-	-	-	72
70100.W0150	Smooth, Through	50	18	10	-	-	-	32	-	-	-	-	130
70100.W0163	Smooth, Through	63	20	12	-	-	-	40	-	-	-	-	220
70100.W0180	Smooth, Through	80	25	16	-	-	-	50	-	-	-	-	440
70100.W0232	Smooth, Blind	32	12	6	-	-	-	20	-	15	12	-	50
70100.W0240	Smooth, Blind	40	14	8	-	-	-	25	-	18	15	-	74
70100.W0250	Smooth, Blind	50	18	10	-	-	-	32	-	21	18	-	135
70100.W0263	Smooth, Blind	63	20	12	-	-	-	40	-	25	22	-	235
70100.W0280	Smooth, Blind	80	25	16	-	-	-	50	-	32	28	-	460
70100.W0332	Threaded, Through	32	12	-	M_6	6.4	-	20	-	-	-	10	49
70100.W0340	Threaded, Through	40	14	-	M_8	8.4	-	25	-	-	-	12	72
70100.W0350	Threaded, Through	50	18	-	M10	10.5	-	32	-	-	-	16	130
70100.W0363	Threaded, Through	63	20	-	M12	13.0	-	40	-	-	-	20	220
70100.W0380	Threaded, Through	80	25	-	M16	17.0	-	50	-	-	-	30	545
70100.W0432	Threaded, Blind	32	12	-	M_6	-	-	20	-	-	12	-	50
70100.W0440	Threaded, Blind	40	14	-	M_8	-	-	25	-	-	15	-	74
70100.W0450	Threaded, Blind	50	18	-	M10	-	-	32	-	-	18	-	135
70100.W0463	Threaded, Blind	63	20	-	M12	-	-	40	-	-	22	-	235
70100.W0480	Threaded, Blind	80	25	-	M16	-	-	50	-	-	28	-	460

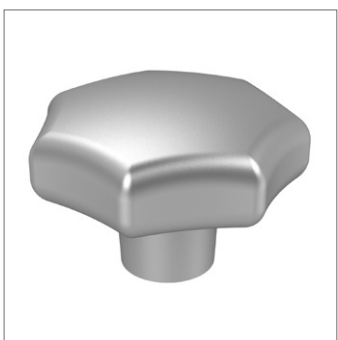
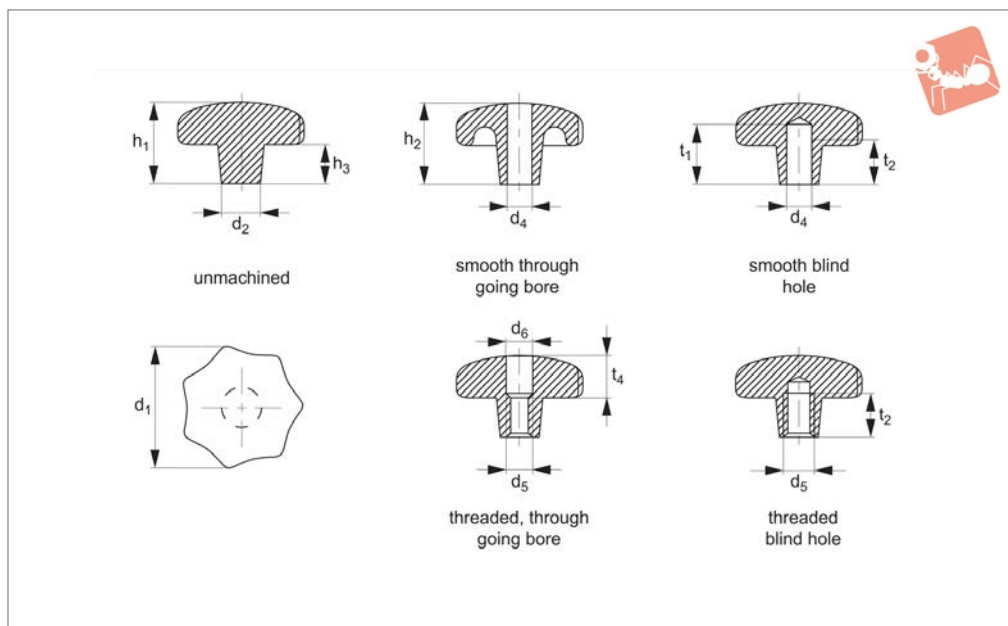
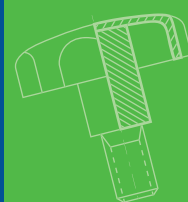

70120

GRIPS

Material

Light metal aluminium (polished or unpolished).

Technical Notes

Produced to DIN 6336.

Order No.	Finish	Type	d ₁	d ₂	d ₄ tol. H7	d ₅	d ₆	h ₁	h ₂	h ₃	t ₁	t ₂	t ₄	Weight g
70120.W0040	Unpolished	Unmachined	40	14	-	-	-	26	-	13	-	-	-	36
70120.W0050	Unpolished	Unmachined	50	18	-	-	-	34	-	17	-	-	-	70
70120.W0063	Unpolished	Unmachined	63	20	-	-	-	42	-	21	-	-	-	128
70120.W0080	Unpolished	Unmachined	80	25	-	-	-	52	-	25	-	-	-	245
70120.W0180	Unpolished	Smooth, Through	80	25	16	-	-	-	50	-	-	-	-	200
70120.W0240	Unpolished	Smooth, Blind	40	14	8	-	-	-	25	-	18	15	-	30
70120.W0250	Unpolished	Smooth, Blind	50	18	10	-	-	-	32	-	21	18	-	63
70120.W0263	Unpolished	Smooth, Blind	63	20	12	-	-	-	40	-	25	22	-	117
70120.W0280	Unpolished	Smooth, Blind	80	25	16	-	-	-	50	-	32	28	-	223
70120.W0340	Unpolished	Threaded, Through	40	14	-	M 8	8.4	-	25	-	-	-	12	32
70120.W0350	Unpolished	Threaded, Through	50	18	-	M10	10.5	-	32	-	-	-	16	32
70120.W0363	Unpolished	Threaded, Through	63	20	-	M12	13.0	-	40	-	-	-	20	109
70120.W0380	Unpolished	Threaded, Through	80	25	-	M16	17.0	-	50	-	-	-	30	218
70120.W0440	Unpolished	Threaded, Blind	40	14	-	M 8	-	-	25	-	-	15	-	33
70120.W0450	Unpolished	Threaded, Blind	50	18	-	M10	-	-	32	-	-	18	-	63
70120.W0463	Unpolished	Threaded, Blind	63	20	-	M12	-	-	40	-	-	22	-	111
70120.W0480	Unpolished	Threaded, Blind	80	25	-	M16	-	-	50	-	-	28	-	227
70120.W0540	Polished	Smooth, Through	40	14	8	-	-	-	25	-	-	-	-	32
70120.W0580	Polished	Smooth, Through	80	25	16	-	-	-	50	-	-	-	-	200
70120.W0640	Polished	Smooth, Blind	40	14	8	-	-	-	25	-	18	15	-	30
70120.W0650	Polished	Smooth, Blind	50	18	10	-	-	-	32	-	21	18	-	63
70120.W0663	Polished	Smooth, Blind	63	20	12	-	-	-	40	-	25	22	-	117
70120.W0680	Polished	Smooth, Blind	80	25	16	-	-	-	50	-	32	28	-	223
70120.W0740	Polished	Threaded, Through	40	14	-	M 8	8.4	-	25	-	-	-	12	32
70120.W0750	Polished	Threaded, Through	50	18	-	M10	10.5	-	32	-	-	-	16	32
70120.W0763	Polished	Threaded, Through	63	20	-	M12	13.0	-	40	-	-	-	20	109
70120.W0780	Polished	Threaded, Through	80	25	-	M16	17.0	-	50	-	-	-	30	218
70120.W0840	Polished	Threaded, Blind	40	14	-	M 8	-	-	25	-	-	15	-	33
70120.W0850	Polished	Threaded, Blind	50	18	-	M10	-	-	32	-	-	18	-	63
70120.W0863	Polished	Threaded, Blind	63	20	-	M12	-	-	40	-	-	22	-	111
70120.W0880	Polished	Threaded, Blind	80	25	-	M16	-	-	50	-	-	28	-	227

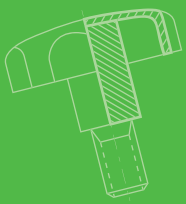

70122

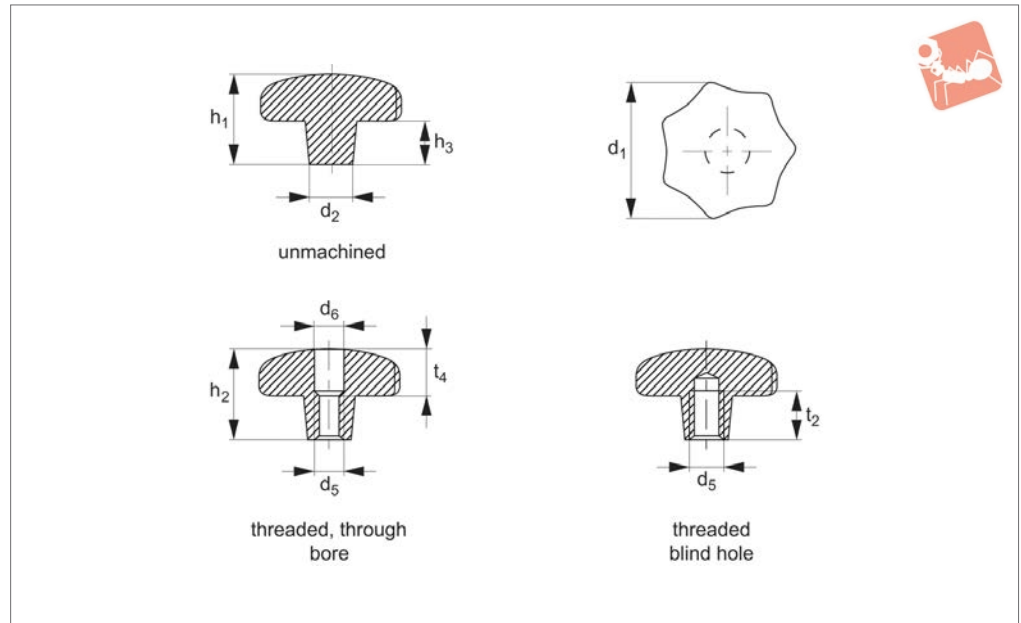
**Material**

Stainless steel A2 (AISI 304), dull blasted.

Order No.	Finish	d ₁	d ₂	d ₅	d ₆	h ₁	h ₂	h ₃	t ₂	t ₄	Weight g
70122.W0032	Unmachined	32	12	-	-	21	-	10	-	-	56
70122.W0040	Unmachined	40	14	-	-	26	-	13	-	-	85
70122.W0050	Unmachined	50	18	-	-	34	-	17	-	-	181
70122.W0063	Unmachined	63	20	-	-	42	-	21	-	-	319
70122.W0332	Threaded, Through	32	12	M 6	6.4	-	20	-	-	10	52
70122.W0340	Threaded, Through	40	14	M 8	8.4	-	25	-	-	12	75
70122.W0350	Threaded, Through	50	18	M10	10.5	-	32	-	-	16	158
70122.W0363	Threaded, Through	63	20	M12	13.0	-	40	-	-	20	279
70122.W0432	Threaded, Blind	32	12	M 6	-	-	20	-	12	-	53
70122.W0440	Threaded, Blind	40	14	M 8	-	-	25	-	15	-	77
70122.W0450	Threaded, Blind	50	18	M10	-	-	32	-	18	-	165
70122.W0463	Threaded, Blind	63	20	M12	-	-	40	-	22	-	296

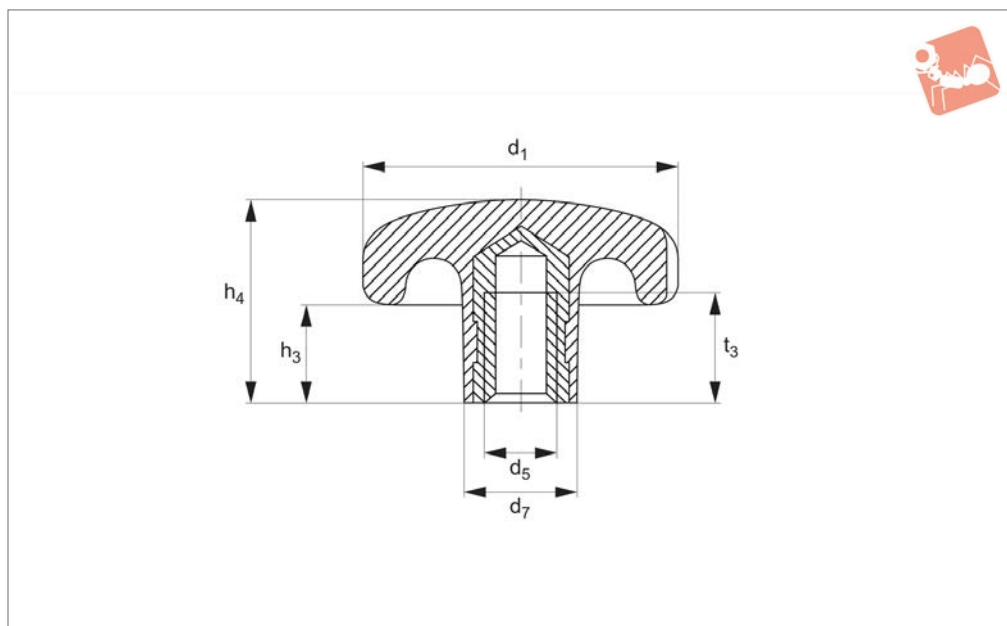
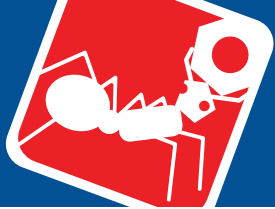

70140

GRIPS

Material

Grip: duroplast PF 31 DIN 7708, black.

Threaded bush: steel, galvanised, stainless

steel A2 or brass.

Technical Notes

Temperature range: max 110°C.

Order No.	Finish	d ₁	d ₅	d ₇	h ₃	h ₄	t ₃	Weight g
70140.W0220	Brass	20	M 4	10	7	13	6.5	3.4
70140.W0225	Steel	25	M 5	12	8	16	9.5	7.4
70140.W0232	Steel	32	M 6	14	10	20	12.0	11.0
70140.W0240	Steel	40	M 8	18	13	25	14.0	22.0
70140.W0250	Steel	50	M10	22	17	32	18.0	40.0
70140.W0263	Steel	63	M12	26	21	40	22.0	83.0
70140.W0280	Steel	80	M16	35	25	50	30.0	163.0
70140.W1225	Stainless	25	M 5	12	8	16	9.5	7.4
70140.W1232	Stainless	32	M 6	14	10	20	12.0	11.0
70140.W1240	Stainless	40	M 8	18	13	25	14.0	22.0
70140.W1250	Stainless	50	M10	22	17	32	18.0	40.0
70140.W1263	Stainless	63	M12	26	21	40	22.0	83.0
70140.W1280	Stainless	80	M16	35	25	50	30.0	163.0



70160

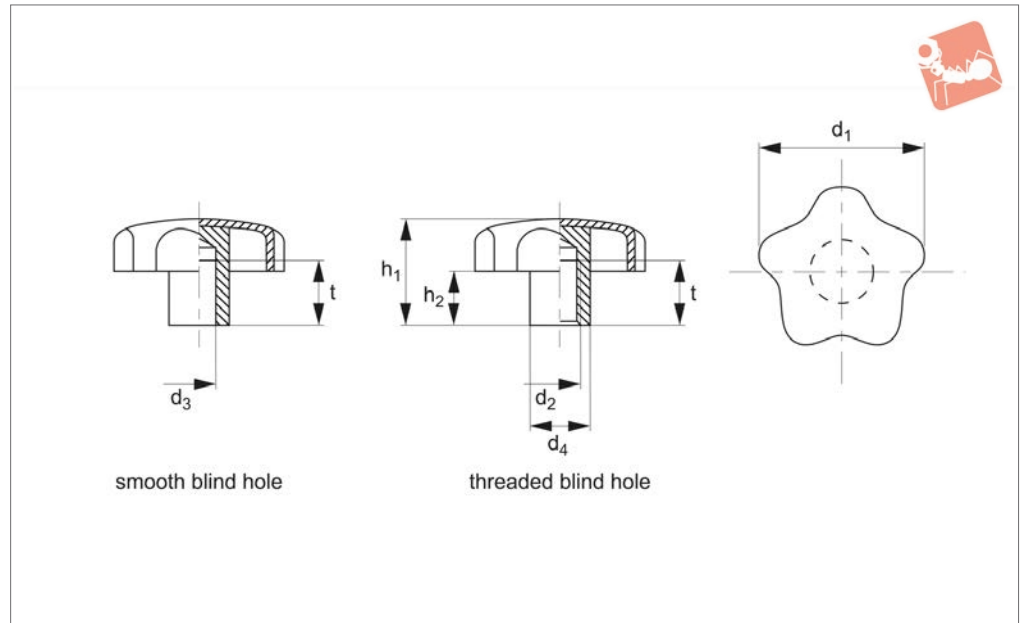

Material

Grip: sheet drawn stainless (AISI 304) dull blasted.

Hub: stainless steel (AISI 304), butt-welded.

Order No.	Finish	d ₁	d ₂	d ₃ tol. H7	d ₄	h ₁	h ₂	t min.	Weight g
70160.W0240	Smooth, Blind	40	-	8	14	25	12.5	15	29
70160.W0250	Smooth, Blind	50	-	10	18	32	17.5	18	67
70160.W0260	Smooth, Blind	60	-	12	20	40	21.0	22	110
70160.W0440	Threaded, Blind	40	M 8	-	14	25	12.5	15	37
70160.W0450	Threaded, Blind	50	M10	-	18	32	17.5	18	69
70160.W0460	Threaded, Blind	60	M12	-	20	40	21.0	22	112



Star Grips

male, stainless steel

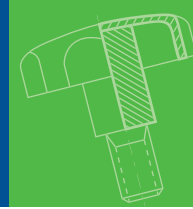

Grips

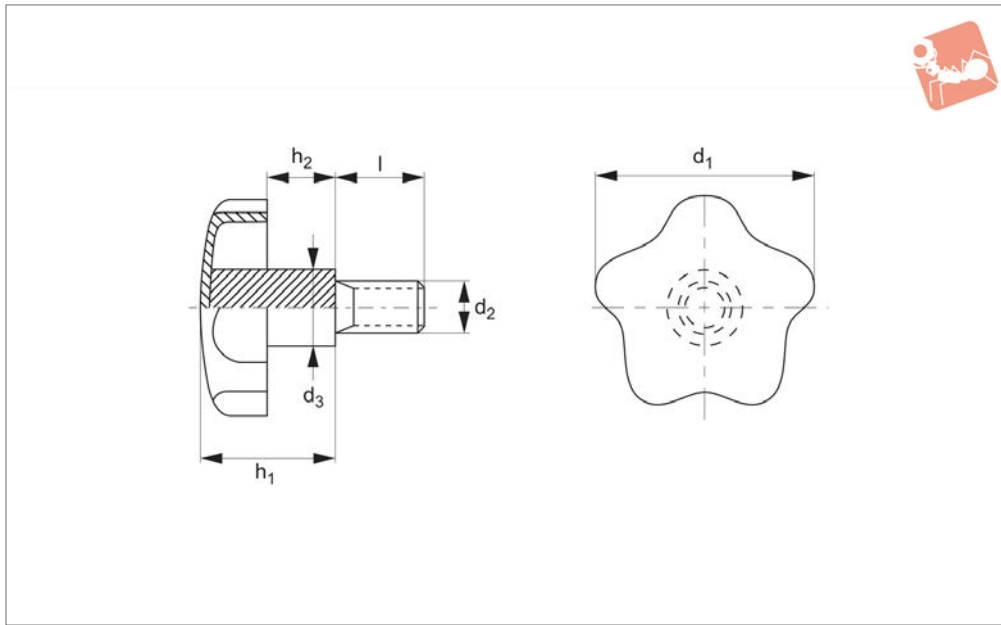

70162

GRIPS

Material

Grip: sheet drawn stainless (AISI 304), dull blasted.

Hub: stainless steel (AISI 304), butt-welded.

Order No.	d ₁	d ₂	d ₃	h ₁ ≈	h ₂ ≈	l	Weight g
70162.W0140	40	M 8	14	24.0	12.0	20	50
70162.W0142	40	M 8	14	24.0	12.0	30	55
70162.W0144	40	M 8	14	24.0	12.0	40	56
70162.W0150	50	M10	18	30.0	16.5	20	95
70162.W0152	50	M10	18	30.0	16.5	30	97
70162.W0154	50	M10	18	30.0	16.5	40	100
70162.W0160	60	M12	20	37.5	20.0	30	155
70162.W0162	60	M12	20	37.5	20.0	40	162
70162.W0164	60	M12	20	37.5	20.0	50	169

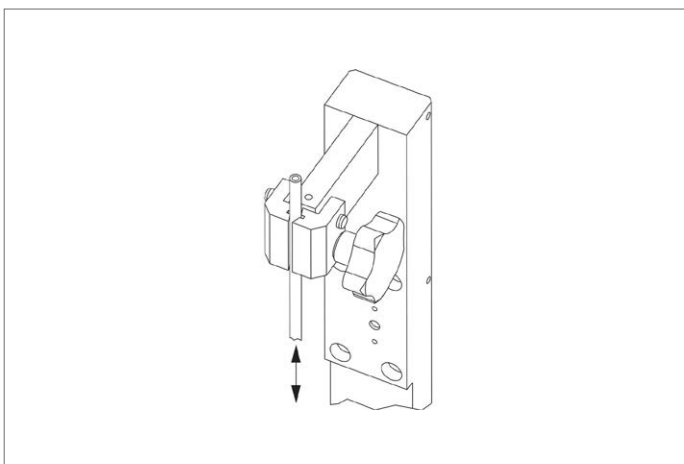



70180

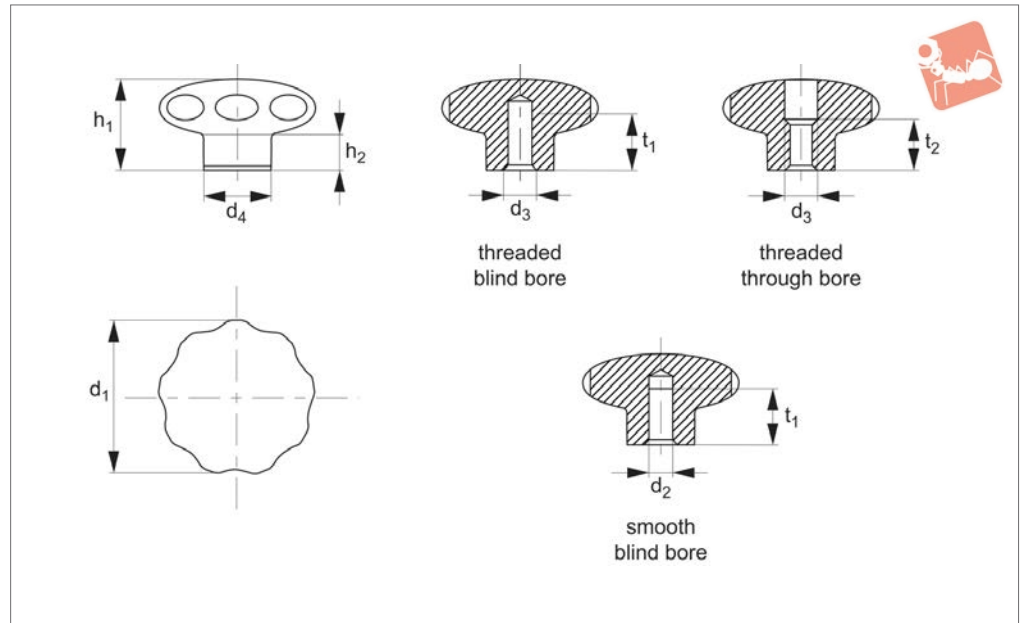

Material

Stainless steel 1.4305 (AISI 303), matt, dull blasted.

development intended for the food processing machinery industry. Large radii and smooth surfaces have been introduced to meet the highest hygienic demands.

Technical Notes

Stainless steel star grips are a special

Order No.	Finish	d ₁	d ₂ tol. H7	d ₃	d ₄	h ₁	h ₂	t ₁ min.	t ₂	Weight g
70180.W0040	Threaded, Blind	40	-	M 6	18	30.5	15	12	-	134
70180.W0041	Threaded, Blind	40	-	M 8	18	30.5	15	12	-	132
70180.W0050	Threaded, Blind	50	-	M 8	21	34.0	17	15	-	226
70180.W0051	Threaded, Blind	50	-	M10	21	34.0	17	15	-	222
70180.W0060	Threaded, Blind	60	-	M10	25	39.0	18	18	-	395
70180.W0061	Threaded, Blind	60	-	M12	25	39.0	18	18	-	384
70180.W0141	Threaded Through	40	-	M 8	18	30.5	15	-	13	129
70180.W0151	Threaded Through	50	-	M10	21	34.0	17	-	16	216
70180.W0161	Threaded Through	60	-	M12	25	39.0	18	-	20	362
70180.W0240	Smooth, Blind	40	8	-	18	30.5	15	12	-	131
70180.W0250	Smooth, Blind	50	10	-	21	34.0	17	15	-	223
70180.W0260	Smooth, Blind	60	12	-	25	39.0	18	18	-	386



Star Grips - 3A Standard

hygienic line, stainless steel



Grips

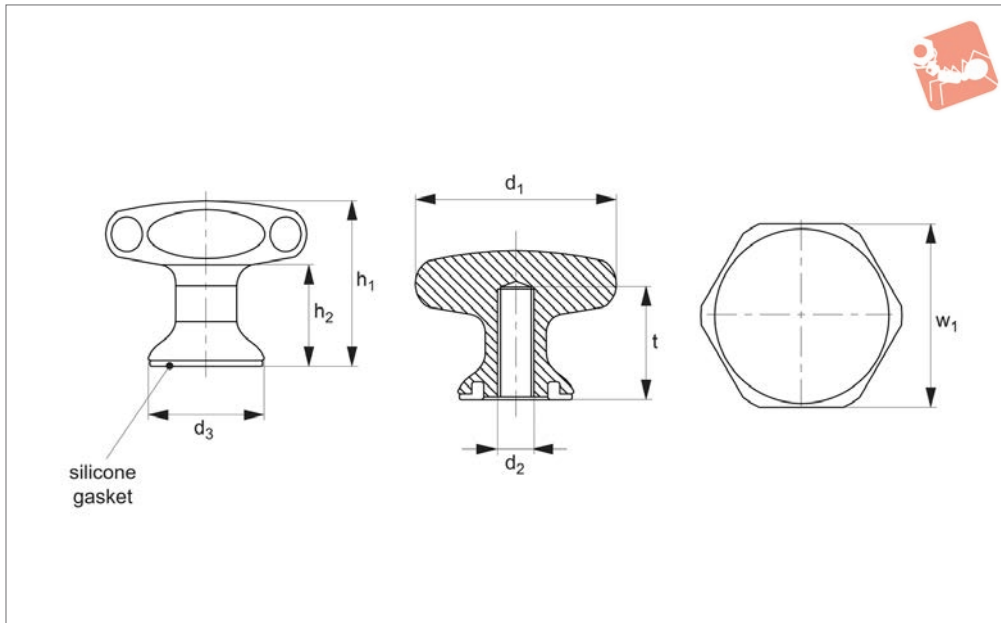

70190

GRIPS

Material

Stainless steel AISI304
Blue gasket: silicone

Tips

Made to the high „3A“ standard.

This ensures it meets the high standards required for use in food, beverage, pharmaceutical and medical applications. Hygienically designed for effective and easy cleaning, corrosion resistant, non-

toxic. Design precludes contamination by dirt, food particles and organic matter.

Order No.	d ₁	d ₂	d ₃	h ₁	h ₂	t	w ₁
70190.W0027	27	M 5	15	20	13	15	24
70190.W0033	33	M 6	19	24	13	20	30
70190.W0040	40	M 8	25	28	16	20	36
70190.W0050	50	M10	25	30	16	25	46
70190.W0065	65	M12	31	40	24	25	60



70500

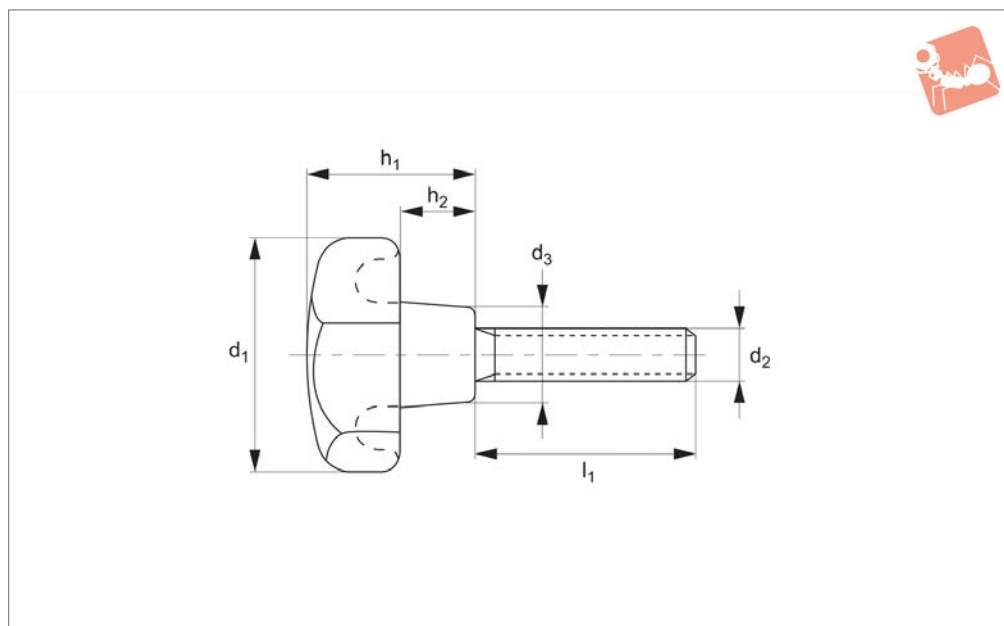

Material

duroplast PF 31, black.
Grub screw: steel, galvanised.

Technical Notes

Produced to DIN 7708.

Special designs e.g. different lengths or grub screws in brass or stainless steel, on request.

Temperature range max. 110°C.
DIN 6336.

Order No.	Material	d ₁	d ₂	d ₃	h ₁	h ₂	l ₁	Weight g
70500.W0051	Steel	25	M 5	12	16	8	10	7.3
70500.W0054	Steel	25	M 5	12	16	8	15	7.2
70500.W0056	Steel	25	M 5	12	16	8	20	8.7
70500.W0058	Steel	25	M 5	12	16	8	25	8.7
70500.W0060	Steel	25	M 5	12	16	8	30	9.2
70500.W0102	Steel	32	M 6	14	20	10	15	14.0
70500.W0104	Steel	32	M 6	14	20	10	20	14.0
70500.W0106	Steel	32	M 6	14	20	10	25	14.0
70500.W0108	Steel	32	M 6	14	20	10	30	16.0
70500.W0110	Steel	32	M 6	14	20	10	40	17.0
70500.W0152	Steel	40	M 8	18	25	13	20	28.0
70500.W0154	Steel	40	M 8	18	25	13	25	30.0
70500.W0156	Steel	40	M 8	18	25	13	30	32.0
70500.W0158	Steel	40	M 8	18	25	13	40	35.0
70500.W0160	Steel	40	M 8	18	25	13	50	38.0
70500.W0202	Steel	50	M10	22	32	17	25	51.0
70500.W0204	Steel	50	M10	22	32	17	30	54.0
70500.W0206	Steel	50	M10	22	32	17	40	60.0
70500.W0208	Steel	50	M10	22	32	17	50	64.0
70500.W0210	Steel	50	M10	22	32	17	60	77.0
70500.W0252	Steel	63	M12	26	40	21	30	101.0
70500.W0254	Steel	63	M12	26	40	21	40	108.0
70500.W0256	Steel	63	M12	26	40	21	50	115.0
70500.W0258	Steel	63	M12	26	40	21	60	121.0
70500.W0260	Steel	63	M12	26	40	21	80	143.0
70500.W0302	Steel	80	M16	35	50	25	40	223.0
70500.W0304	Steel	80	M16	35	50	25	50	237.0
70500.W0306	Steel	80	M16	35	50	25	60	232.0
70500.W0308	Steel	80	M16	35	50	25	80	274.0
70500.W1051	Stainless Steel	25	M 5	12	16	8	10	7.3
70500.W1054	Stainless Steel	25	M 5	12	16	8	15	7.2
70500.W1056	Stainless Steel	25	M 5	12	16	8	20	8.7



Star Grips

with grub screw - DIN 6336

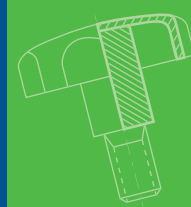

Grips

Order No.	Material	d ₁	d ₂	d ₃	h ₁	h ₂	l ₁	Weight g
70500.W1058	Stainless Steel	25	M 5	12	16	8	25	8.7
70500.W1060	Stainless Steel	25	M 5	12	16	8	30	9.2
70500.W1102	Stainless Steel	32	M 6	14	20	10	15	14.0
70500.W1104	Stainless Steel	32	M 6	14	20	10	20	14.0
70500.W1106	Stainless Steel	32	M 6	14	20	10	25	14.0
70500.W1108	Stainless Steel	32	M 6	14	20	10	30	16.0
70500.W1110	Stainless Steel	32	M 6	14	20	10	40	17.0
70500.W1152	Stainless Steel	40	M 8	18	25	13	20	28.0
70500.W1154	Stainless Steel	40	M 8	18	25	13	25	30.0
70500.W1156	Stainless Steel	40	M 8	18	25	13	30	32.0
70500.W1158	Stainless Steel	40	M 8	18	25	13	40	35.0
70500.W1160	Stainless Steel	40	M 8	18	25	13	50	38.0
70500.W1202	Stainless Steel	50	M10	22	32	17	25	51.0
70500.W1204	Stainless Steel	50	M10	22	32	17	30	54.0
70500.W1206	Stainless Steel	50	M10	22	32	17	40	60.0
70500.W1208	Stainless Steel	50	M10	22	32	17	50	64.0
70500.W1210	Stainless Steel	50	M10	22	32	17	60	77.0
70500.W1252	Stainless Steel	63	M12	26	40	21	30	101.0
70500.W1254	Stainless Steel	63	M12	26	40	21	40	108.0
70500.W1256	Stainless Steel	63	M12	26	40	21	50	115.0
70500.W1258	Stainless Steel	63	M12	26	40	21	60	121.0
70500.W1260	Stainless Steel	63	M12	26	40	21	80	143.0
70500.W1302	Stainless Steel	80	M16	35	50	25	40	223.0
70500.W1304	Stainless Steel	80	M16	35	50	25	50	237.0
70500.W1306	Stainless Steel	80	M16	35	50	25	60	232.0
70500.W1308	Stainless Steel	80	M16	35	50	25	80	274.0

GRIPS



70600

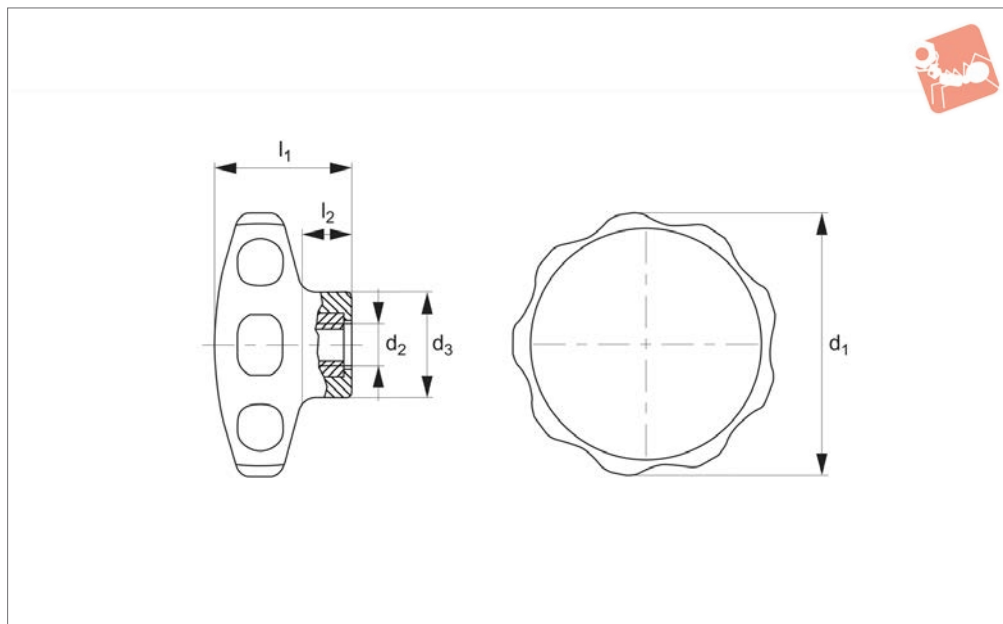

Material

Grip: thermoplast (PA 6) Black RAL 9005.
Cap: thermoplast (PA 6)
Black RAL 9005, White RAL 9019, Yellow RAL 1016, Orange RAL 2004, Blue RAL

5015.
Threaded bush: stainless steel.

Technical Notes
Temperature range - 30°C to + 80°C.

Special types e.g. differing threads available on request, subject to minimum quantity.

Order No.	Colour	d ₁	d ₂	d ₃	l ₁	l ₂	Weight g
70600.W0030	Black	30	M 4	14.0	19	7	5.3
70600.W0031	White	30	M 4	14.0	19	7	5.3
70600.W0032	Orange	30	M 4	14.0	19	7	5.3
70600.W0033	Yellow	30	M 4	14.0	19	7	5.3
70600.W0034	Blue	30	M 4	14.0	19	7	5.3
70600.W0035	Black	30	M 5	14.0	19	7	5.7
70600.W0036	White	30	M 5	14.0	19	7	5.7
70600.W0037	Orange	30	M 5	14.0	19	7	5.7
70600.W0038	Yellow	30	M 5	14.0	19	7	5.7
70600.W0039	Blue	30	M 5	14.0	19	7	5.7
70600.W0040	Black	40	M 5	16.5	22	9	8.2
70600.W0041	White	40	M 5	16.5	22	9	8.2
70600.W0042	Orange	40	M 5	16.5	22	9	8.2
70600.W0043	Yellow	40	M 5	16.5	22	9	8.2
70600.W0044	Blue	40	M 5	16.5	22	9	8.2
70600.W0045	Black	40	M 6	16.5	22	9	9.5
70600.W0046	White	40	M 6	16.5	22	9	9.5
70600.W0047	Orange	40	M 6	16.5	22	9	9.5
70600.W0048	Yellow	40	M 6	16.5	22	9	9.5
70600.W0049	Blue	40	M 6	16.5	22	9	9.5
70600.W0050	Black	50	M 6	22.0	26	10	16.0
70600.W0051	White	50	M 6	22.0	26	10	16.0
70600.W0052	Orange	50	M 6	22.0	26	10	16.0
70600.W0053	Yellow	50	M 6	22.0	26	10	16.0
70600.W0054	Blue	50	M 6	22.0	26	10	16.0
70600.W0055	Black	50	M 8	22.0	26	10	19.0
70600.W0056	White	50	M 8	22.0	26	10	19.0
70600.W0057	Orange	50	M 8	22.0	26	10	19.0
70600.W0058	Yellow	50	M 8	22.0	26	10	19.0
70600.W0059	Blue	50	M 8	22.0	26	10	19.0
70600.W0060	Black	62	M 8	22.0	35	13	19.0
70600.W0061	White	62	M 8	22.0	35	13	19.0
70600.W0062	Orange	62	M 8	22.0	35	13	19.0

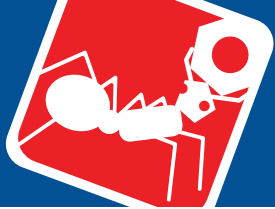

Star Grips with stainless steel bush



Grips

Order No.	Colour	d ₁	d ₂	d ₃	l ₁	l ₂	Weight g
70600.W0063	Yellow	62	M 8	22.0	35	13	19.0
70600.W0064	Blue	62	M 8	22.0	35	13	19.0
70600.W0065	Black	62	M10	22.0	35	13	39.0
70600.W0066	White	62	M10	22.0	35	13	39.0
70600.W0067	Orange	62	M10	22.0	35	13	39.0
70600.W0068	Yellow	62	M10	22.0	35	13	39.0
70600.W0069	Blue	62	M10	22.0	35	13	39.0



70610

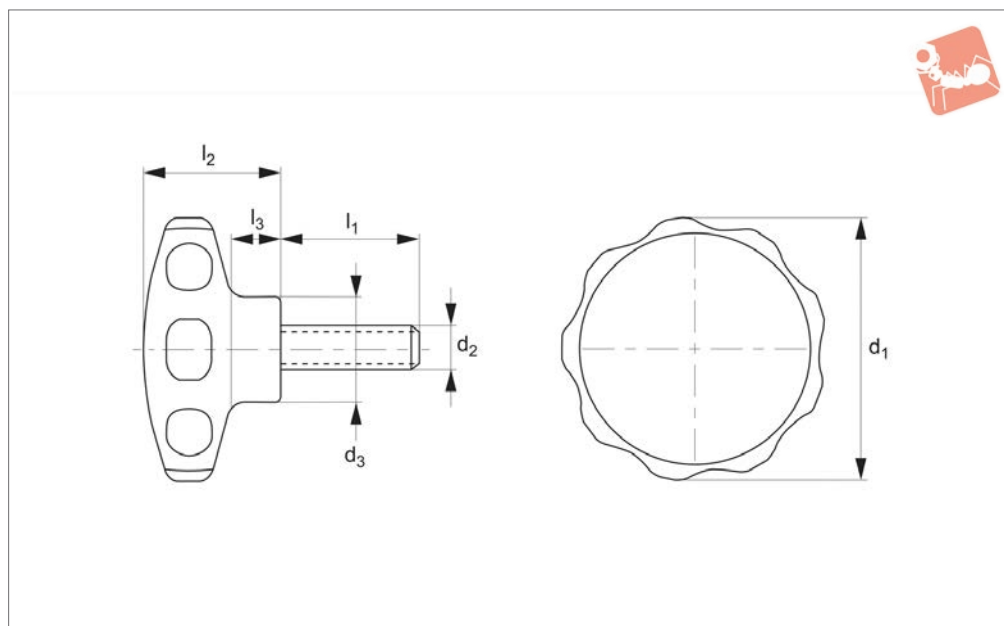

Material

Grip: thermoplast (PA 6) Black RAL 9005.
Cap: thermoplast (PA 6)
Black RAL 9005, white RAL 9019, orange
RAL 2004, yellow RAL 1016, blue RAL

5015.

Threaded bush: stainless steel.

Technical Notes

Temperature range -30°C to +80°C.

Special types e.g. differing threads
available on request, subject to minimum
order quantity.

Order No.	Colour	d ₁	d ₂	d ₃	l ₁	l ₂	l ₃	Weight g
70610.W0100	Black	30	M 4	14.0	10	19	7	6.1
70610.W0101	White	30	M 4	14.0	10	19	7	6.1
70610.W0102	Orange	30	M 4	14.0	10	19	7	6.1
70610.W0103	Yellow	30	M 4	14.0	10	19	7	6.1
70610.W0104	Blue	30	M 4	14.0	10	19	7	6.1
70610.W0110	Black	30	M 4	14.0	14	19	7	6.6
70610.W0111	White	30	M 4	14.0	14	19	7	6.6
70610.W0112	Orange	30	M 4	14.0	14	19	7	6.6
70610.W0113	Yellow	30	M 4	14.0	14	19	7	6.6
70610.W0114	Blue	30	M 4	14.0	14	19	7	6.6
70610.W0120	Black	30	M 4	14.0	18	19	7	6.9
70610.W0121	White	30	M 4	14.0	18	19	7	6.9
70610.W0122	Orange	30	M 4	14.0	18	19	7	6.9
70610.W0123	Yellow	30	M 4	14.0	18	19	7	6.9
70610.W0124	Blue	30	M 4	14.0	18	19	7	6.9
70610.W0130	Black	30	M 4	14.0	23	19	7	7.3
70610.W0131	White	30	M 4	14.0	23	19	7	7.3
70610.W0132	Orange	30	M 4	14.0	23	19	7	7.3
70610.W0133	Yellow	30	M 4	14.0	23	19	7	7.3
70610.W0134	Blue	30	M 4	14.0	23	19	7	7.3
70610.W0140	Black	30	M 4	14.0	28	19	7	7.7
70610.W0141	White	30	M 4	14.0	28	19	7	7.7
70610.W0142	Orange	30	M 4	14.0	28	19	7	7.7
70610.W0143	Yellow	30	M 4	14.0	28	19	7	7.7
70610.W0144	Blue	30	M 4	14.0	28	19	7	7.7
70610.W0150	Black	30	M 5	14.0	10	19	7	7.1
70610.W0151	White	30	M 5	14.0	10	19	7	7.1
70610.W0152	Orange	30	M 5	14.0	10	19	7	7.1
70610.W0153	Yellow	30	M 5	14.0	10	19	7	7.1
70610.W0154	Blue	30	M 5	14.0	10	19	7	7.1
70610.W0160	Black	30	M 5	14.0	14	19	7	7.9
70610.W0161	White	30	M 5	14.0	14	19	7	7.9
70610.W0162	Orange	30	M 5	14.0	14	19	7	7.9



Star Grips

with stainless steel grub screw

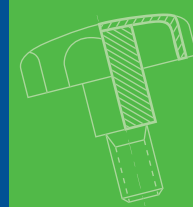

Grips

Order No.	Colour	d ₁	d ₂	d ₃	l ₁	l ₂	l ₃	Weight g
70610.W0163	Yellow	30	M 5	14.0	14	19	7	7.9
70610.W0164	Blue	30	M 5	14.0	14	19	7	7.9
70610.W0170	Black	30	M 5	14.0	18	19	7	8.4
70610.W0171	White	30	M 5	14.0	18	19	7	8.4
70610.W0172	Orange	30	M 5	14.0	18	19	7	8.4
70610.W0173	Yellow	30	M 5	14.0	18	19	7	8.4
70610.W0174	Blue	30	M 5	14.0	18	19	7	8.4
70610.W0180	Black	30	M 5	14.0	23	19	7	9.0
70610.W0181	White	30	M 5	14.0	23	19	7	9.0
70610.W0182	Orange	30	M 5	14.0	23	19	7	9.0
70610.W0183	Yellow	30	M 5	14.0	23	19	7	9.0
70610.W0184	Blue	30	M 5	14.0	23	19	7	9.0
70610.W0190	Black	30	M 5	14.0	28	19	7	9.0
70610.W0191	White	30	M 5	14.0	28	19	7	9.0
70610.W0192	Orange	30	M 5	14.0	28	19	7	9.0
70610.W0193	Yellow	30	M 5	14.0	28	19	7	9.0
70610.W0194	Blue	30	M 5	14.0	28	19	7	9.0
70610.W0200	Black	40	M 5	16.5	10	22	9	9.6
70610.W0201	White	40	M 5	16.5	10	22	9	9.6
70610.W0202	Orange	40	M 5	16.5	10	22	9	9.6
70610.W0203	Yellow	40	M 5	16.5	10	22	9	9.6
70610.W0204	Blue	40	M 5	16.5	10	22	9	9.6
70610.W0210	Black	40	M 5	16.5	14	22	9	10.0
70610.W0211	White	40	M 5	16.5	14	22	9	10.0
70610.W0212	Orange	40	M 5	16.5	14	22	9	10.0
70610.W0213	Yellow	40	M 5	16.5	14	22	9	10.0
70610.W0214	Blue	40	M 5	16.5	14	22	9	10.0
70610.W0220	Black	40	M 5	16.5	18	22	9	11.0
70610.W0221	White	40	M 5	16.5	18	22	9	11.0
70610.W0222	Orange	40	M 5	16.5	18	22	9	11.0
70610.W0223	Yellow	40	M 5	16.5	18	22	9	11.0
70610.W0224	Blue	40	M 5	16.5	18	22	9	11.0
70610.W0230	Black	40	M 5	16.5	23	22	9	12.0
70610.W0231	White	40	M 5	16.5	23	22	9	12.0
70610.W0232	Orange	40	M 5	16.5	23	22	9	12.0
70610.W0233	Yellow	40	M 5	16.5	23	22	9	12.0
70610.W0234	Blue	40	M 5	16.5	23	22	9	12.0
70610.W0250	Black	40	M 6	16.5	14	22	9	12.0
70610.W0251	White	40	M 6	16.5	14	22	9	12.0
70610.W0252	Orange	40	M 6	16.5	14	22	9	12.0
70610.W0253	Yellow	40	M 6	16.5	14	22	9	12.0
70610.W0254	Blue	40	M 6	16.5	14	22	9	12.0
70610.W0260	Black	40	M 6	16.5	18	22	9	13.0
70610.W0261	White	40	M 6	16.5	18	22	9	13.0
70610.W0262	Orange	40	M 6	16.5	18	22	9	13.0
70610.W0263	Yellow	40	M 6	16.5	18	22	9	13.0
70610.W0264	Blue	40	M 6	16.5	18	22	9	13.0
70610.W0270	Black	40	M 6	16.5	23	22	9	14.0
70610.W0271	White	40	M 6	16.5	23	22	9	14.0
70610.W0272	Orange	40	M 6	16.5	23	22	9	14.0
70610.W0273	Yellow	40	M 6	16.5	23	22	9	14.0
70610.W0274	Blue	40	M 6	16.5	23	22	9	14.0
70610.W0280	Black	40	M 6	16.5	28	22	9	15.0
70610.W0281	White	40	M 6	16.5	28	22	9	15.0
70610.W0282	Orange	40	M 6	16.5	28	22	9	15.0
70610.W0283	Yellow	40	M 6	16.5	28	22	9	15.0
70610.W0284	Blue	40	M 6	16.5	28	22	9	15.0
70610.W0290	Black	40	M 6	16.5	38	22	9	16.0
70610.W0291	White	40	M 6	16.5	38	22	9	16.0
70610.W0292	Orange	40	M 6	16.5	38	22	9	16.0
70610.W0293	Yellow	40	M 6	16.5	38	22	9	16.0
70610.W0294	Blue	40	M 6	16.5	38	22	9	16.0
70610.W0300	Black	50	M 6	22.0	14	26	10	19.0
70610.W0301	White	50	M 6	22.0	14	26	10	19.0
70610.W0302	Orange	50	M 6	22.0	14	26	10	19.0
70610.W0303	Yellow	50	M 6	22.0	14	26	10	19.0
70610.W0304	Blue	50	M 6	22.0	14	26	10	19.0
70610.W0310	Black	50	M 6	22.0	18	26	10	19.0

GRIPS



Order No.	Colour	d ₁	d ₂	d ₃	l ₁	l ₂	l ₃	Weight g
70610.W0311	White	50	M 6	22.0	18	26	10	19.0
70610.W0312	Orange	50	M 6	22.0	18	26	10	19.0
70610.W0313	Yellow	50	M 6	22.0	18	26	10	19.0
70610.W0314	Blue	50	M 6	22.0	18	26	10	19.0
70610.W0320	Black	50	M 6	22.0	23	26	10	20.0
70610.W0321	White	50	M 6	22.0	23	26	10	20.0
70610.W0322	Orange	50	M 6	22.0	23	26	10	20.0
70610.W0323	Yellow	50	M 6	22.0	23	26	10	20.0
70610.W0324	Blue	50	M 6	22.0	23	26	10	20.0
70610.W0330	Black	50	M 6	22.0	28	26	10	21.0
70610.W0331	White	50	M 6	22.0	28	26	10	21.0
70610.W0332	Orange	50	M 6	22.0	28	26	10	21.0
70610.W0333	Yellow	50	M 6	22.0	28	26	10	21.0
70610.W0334	Blue	50	M 6	22.0	28	26	10	21.0
70610.W0340	Black	50	M 6	22.0	38	26	10	23.0
70610.W0341	White	50	M 6	22.0	38	26	10	23.0
70610.W0342	Orange	50	M 6	22.0	38	26	10	23.0
70610.W0343	Yellow	50	M 6	22.0	38	26	10	23.0
70610.W0344	Blue	50	M 6	22.0	38	26	10	23.0
70610.W0350	Black	50	M 8	22.0	18	26	10	26.0
70610.W0351	White	50	M 8	22.0	18	26	10	26.0
70610.W0352	Orange	50	M 8	22.0	18	26	10	26.0
70610.W0353	Yellow	50	M 8	22.0	18	26	10	26.0
70610.W0354	Blue	50	M 8	22.0	18	26	10	26.0
70610.W0360	Black	50	M 8	22.0	23	26	10	27.0
70610.W0361	White	50	M 8	22.0	23	26	10	27.0
70610.W0362	Orange	50	M 8	22.0	23	26	10	27.0
70610.W0363	Yellow	50	M 8	22.0	23	26	10	27.0
70610.W0364	Blue	50	M 8	22.0	23	26	10	27.0
70610.W0370	Black	50	M 8	22.0	28	26	10	29.0
70610.W0371	White	50	M 8	22.0	28	26	10	29.0
70610.W0372	Orange	50	M 8	22.0	28	26	10	29.0
70610.W0373	Yellow	50	M 8	22.0	28	26	10	29.0
70610.W0374	Blue	50	M 8	22.0	28	26	10	29.0
70610.W0380	Black	50	M 8	22.0	38	26	10	32.0
70610.W0381	White	50	M 8	22.0	38	26	10	32.0
70610.W0382	Orange	50	M 8	22.0	38	26	10	32.0
70610.W0383	Yellow	50	M 8	22.0	38	26	10	32.0
70610.W0384	Blue	50	M 8	22.0	38	26	10	32.0
70610.W0390	Black	50	M 8	22.0	48	26	10	35.0
70610.W0391	White	50	M 8	22.0	48	26	10	35.0
70610.W0392	Orange	50	M 8	22.0	48	26	10	35.0
70610.W0393	Yellow	50	M 8	22.0	48	26	10	35.0
70610.W0394	Blue	50	M 8	22.0	48	26	10	35.0
70610.W0400	Black	62	M 8	22.0	18	35	13	40.0
70610.W0401	White	62	M 8	22.0	18	35	13	40.0
70610.W0402	Orange	62	M 8	22.0	18	35	13	40.0
70610.W0403	Yellow	62	M 8	22.0	18	35	13	40.0
70610.W0404	Blue	62	M 8	22.0	18	35	13	40.0
70610.W0410	Black	62	M 8	22.0	23	35	13	41.0
70610.W0411	White	62	M 8	22.0	23	35	13	41.0
70610.W0412	Orange	62	M 8	22.0	23	35	13	41.0
70610.W0413	Yellow	62	M 8	22.0	23	35	13	41.0
70610.W0414	Blue	62	M 8	22.0	23	35	13	41.0
70610.W0420	Black	62	M 8	22.0	28	35	13	43.0
70610.W0421	White	62	M 8	22.0	28	35	13	43.0
70610.W0422	Orange	62	M 8	22.0	28	35	13	43.0
70610.W0423	Yellow	62	M 8	22.0	28	35	13	43.0
70610.W0424	Blue	62	M 8	22.0	28	35	13	43.0
70610.W0430	Black	62	M 8	22.0	38	35	13	46.0
70610.W0431	White	62	M 8	22.0	38	35	13	46.0
70610.W0432	Orange	62	M 8	22.0	38	35	13	46.0
70610.W0433	Yellow	62	M 8	22.0	38	35	13	46.0
70610.W0434	Blue	62	M 8	22.0	38	35	13	46.0
70610.W0440	Black	62	M 8	22.0	48	35	13	49.0
70610.W0441	White	62	M 8	22.0	48	35	13	49.0
70610.W0442	Orange	62	M 8	22.0	48	35	13	49.0
70610.W0443	Yellow	62	M 8	22.0	48	35	13	49.0



Star Grips

with stainless steel grub screw



Grips

Order No.	Colour	d ₁	d ₂	d ₃	l ₁	l ₂	l ₃	Weight g
70610.W0444	Blue	62	M 8	22.0	48	35	13	49.0
70610.W0450	Black	62	M10	22.0	23	35	13	51.0
70610.W0451	White	62	M10	22.0	23	35	13	51.0
70610.W0452	Orange	62	M10	22.0	23	35	13	51.0
70610.W0453	Yellow	62	M10	22.0	23	35	13	51.0
70610.W0454	Blue	62	M10	22.0	23	35	13	51.0
70610.W0460	Black	62	M10	22.0	28	35	13	54.0
70610.W0461	White	62	M10	22.0	28	35	13	54.0
70610.W0462	Orange	62	M10	22.0	28	35	13	54.0
70610.W0463	Yellow	62	M10	22.0	28	35	13	54.0
70610.W0464	Blue	62	M10	22.0	28	35	13	54.0
70610.W0470	Black	62	M10	22.0	38	35	13	59.0
70610.W0471	White	62	M10	22.0	38	35	13	59.0
70610.W0472	Orange	62	M10	22.0	38	35	13	59.0
70610.W0473	Yellow	62	M10	22.0	38	35	13	59.0
70610.W0474	Blue	62	M10	22.0	38	35	13	59.0
70610.W0480	Black	62	M10	22.0	48	35	13	64.0
70610.W0481	White	62	M10	22.0	48	35	13	64.0
70610.W0482	Orange	62	M10	22.0	48	35	13	64.0
70610.W0483	Yellow	62	M10	22.0	48	35	13	64.0
70610.W0484	Blue	62	M10	22.0	48	35	13	64.0
70610.W0490	Black	62	M10	22.0	58	35	13	69.0
70610.W0491	White	62	M10	22.0	58	35	13	69.0
70610.W0492	Orange	62	M10	22.0	58	35	13	69.0
70610.W0493	Yellow	62	M10	22.0	58	35	13	69.0
70610.W0494	Blue	62	M10	22.0	58	35	13	69.0

GRIPS



72410

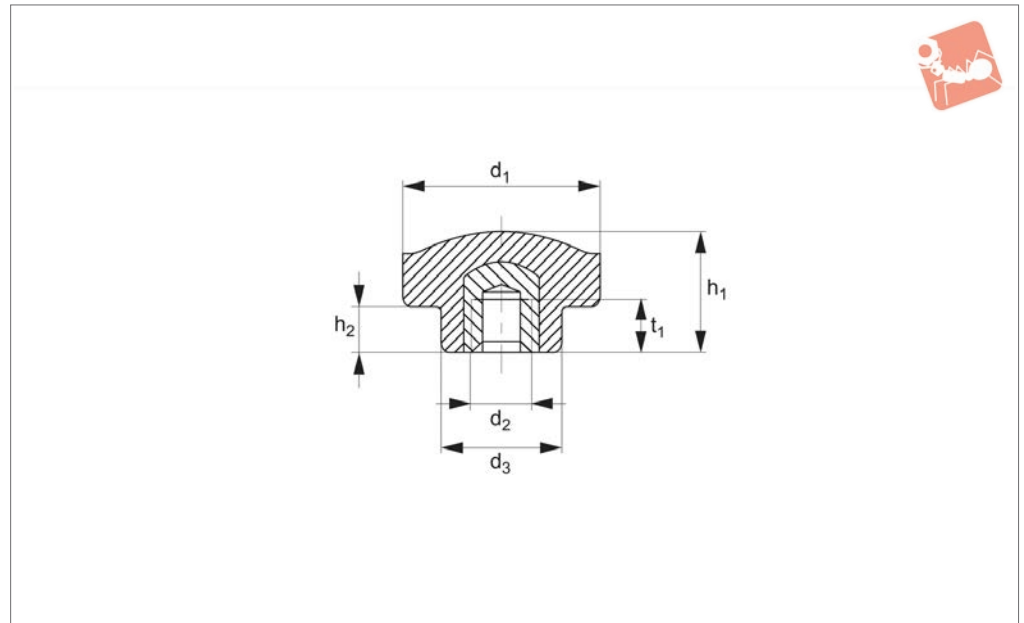

Material

Brass bush with tapped hole. Thermoplastic, black, matt.

Order No.	d_1	d_2	d_3	h_1	h_2	t_1	Weight g
72410.W0224	22	M 4	15	14	6	8	7
72410.W0225	22	M 5	15	14	6	8	8
72410.W0226	22	M 6	15	14	6	8	8
72410.W0228	22	M 8	15	14	6	8	7
72410.W0244	24	M 4	15	14	6	8	8
72410.W0245	24	M 5	15	14	6	8	9
72410.W0246	24	M 6	15	14	6	8	7
72410.W0248	24	M 8	15	14	6	8	8
72410.W0264	26	M 4	16	15	6	8	11
72410.W0265	26	M 5	16	15	6	8	11
72410.W0266	26	M 6	16	15	6	8	11
72410.W0268	26	M 8	16	15	6	8	10

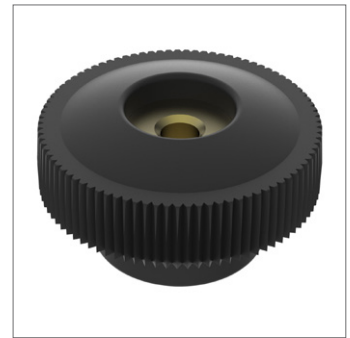
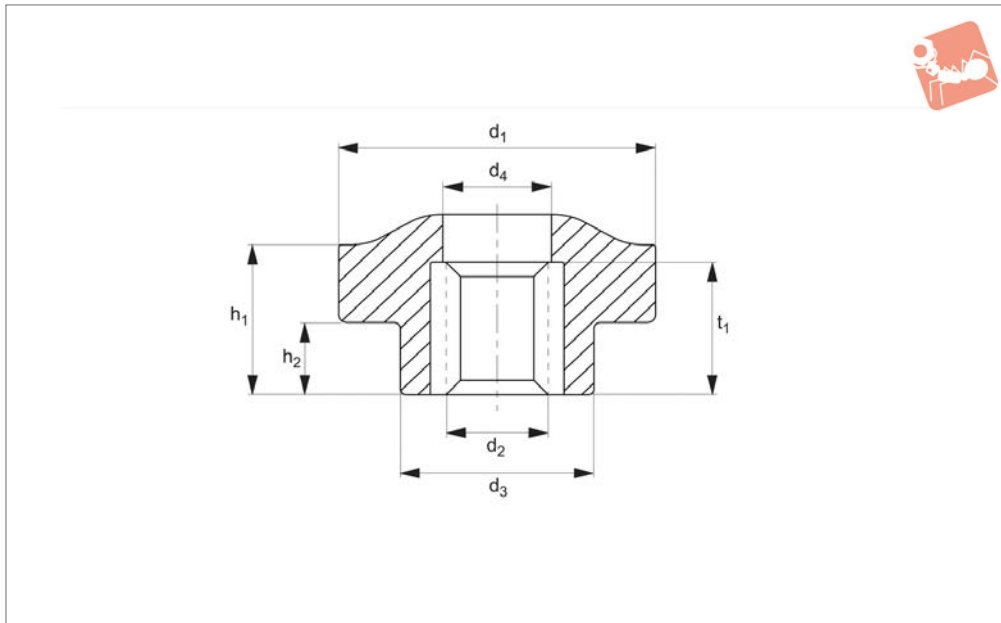
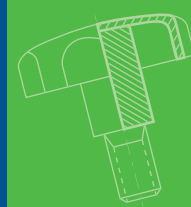

72420

GRIPS

Material

Brass bush with tapped through hole.
Thermoplastic, black, matt.

Order No.	d ₁	d ₂	d ₃	d ₄	h ₁	h ₂	t ₁	Weight g
72420.W0154	15	M 4	11	7	14	7	11	4
72420.W0155	15	M 5	11	7	14	7	11	4
72420.W0224	22	M 4	15	9	14	6	11	7
72420.W0225	22	M 5	15	9	14	6	11	7
72420.W0226	22	M 6	15	9	14	6	11	7
72420.W0228	22	M 8	15	9	14	6	11	7
72420.W0244	24	M 4	15	9	14	6	11	7
72420.W0245	24	M 5	15	9	14	6	11	9
72420.W0246	24	M 6	15	9	14	6	11	8
72420.W0248	24	M 8	15	9	14	6	11	8
72420.W0264	26	M 4	16	9	15	6	11	9
72420.W0265	26	M 5	16	9	15	6	11	9
72420.W0266	26	M 6	16	9	15	6	11	9
72420.W0268	26	M 8	16	9	15	6	11	9
72420.W0326	32	M 6	19	9	18	8	11	11
72420.W0328	32	M 8	19	9	18	8	11	12

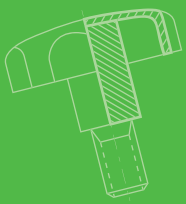

72430

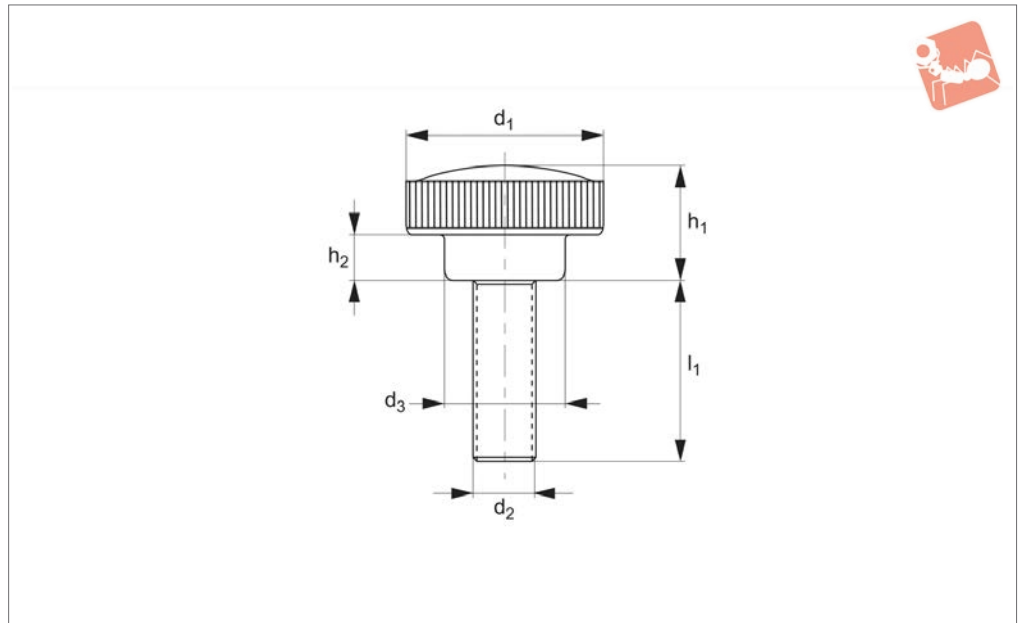
**Material**

Zinc plated steel stud. Thermoplastic,
black, matt.

Order No.	d ₁	d ₂	d ₃	h ₁	h ₂	l ₁	Weight g
72430.W0151	15	M 4	11	14	7	10	4.0
72430.WX151	15	M 4	11	14	7	15	4.0
72430.W0152	15	M 5	11	14	7	10	4.0
72430.W0220	22	M 4	15	14	6	10	6.0
72430.W0221	22	M 4	15	14	6	25	6.0
72430.WX221	22	M 5	10	14	6	15	7.0
72430.W0222	22	M 5	15	14	6	15	7.0
72430.WX222	22	M 6	15	14	6	10	8.0
72430.W0223	22	M 6	15	14	6	15	8.0
72430.WX223	22	M 6	15	14	6	20	9.0
72430.W0224	22	M 6	15	14	6	25	9.0
72430.W0225	22	M 6	15	14	6	30	11.0
72430.WX225	22	M 6	15	14	6	35	12.0
72430.W0226	22	M 6	15	14	6	40	13.0
72430.W0241	24	M 4	15	14	6	10	5.0
72430.W0242	24	M 4	15	14	6	25	6.0
72430.W0243	24	M 5	15	14	6	10	8.0
72430.W0244	24	M 6	15	14	6	10	6.0
72430.WX244	24	M 6	15	14	6	15	10
72430.W0245	24	M 6	15	14	6	25	11.0
72430.W0250	26	M 5	15	14	6	10	9.0
72430.W0261	26	M 5	16	15	6	15	10.0
72430.W0262	26	M 5	16	15	6	25	11.0
72430.WX262	26	M 6	16	15	6	10	10
72430.W0263	26	M 6	16	15	6	15	11.0
72430.W0264	26	M 6	16	15	6	20	12.0
72430.W0265	26	M 6	16	15	6	25	13.0
72430.W0266	26	M 6	16	15	6	40	15.0
72430.W0267	26	M 8	16	15	6	25	17.0
72430.W0268	32	M 6	19	18	8	15	13
72430.W0269	32	M 6	19	18	8	0	14
72430.W0270	32	M 6	19	18	8	25	15
72430.W0271	32	M 6	19	18	8	30	16
72430.W0272	32	M 6	19	18	8	40	18



Knurled Knobs

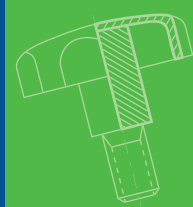

Grips

Order No.	d ₁	d ₂	d ₃	h ₁	h ₂	l ₁	Weight g
72430.W0273	32	M 8	19	18	8	15	19
72430.W0274	32	M 8	19	18	8	25	22
72430.W0275	32	M 8	19	18	8	40	27



72440

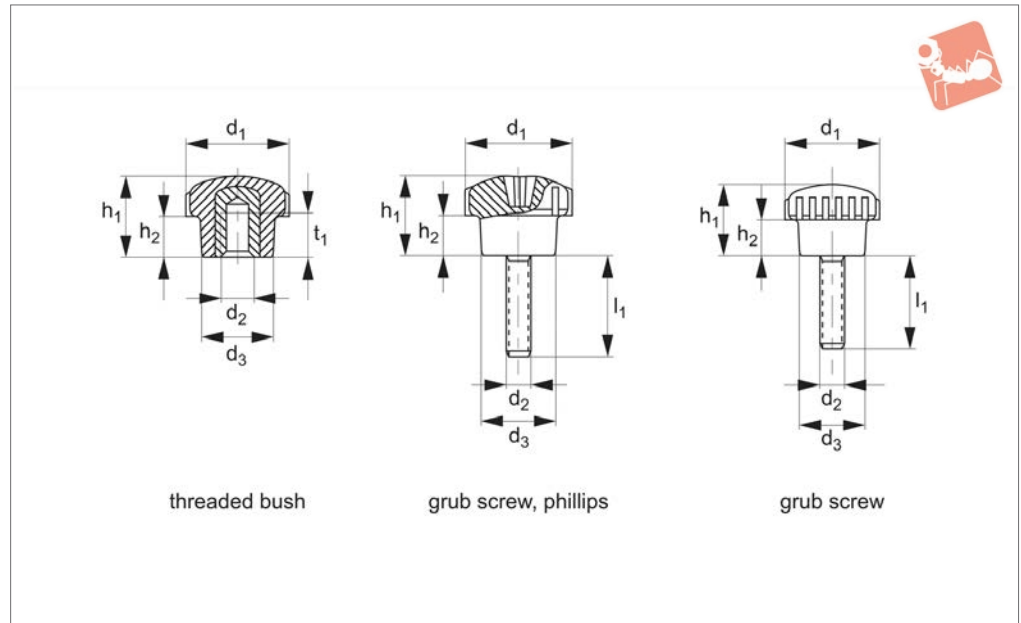

Material

Thermoplastic, black.
Female type - brass bush.

Male type - zinc plated steel stud.

Order No.	Type	d ₁	d ₂	d ₃	h ₁	h ₂	l ₁	t ₁	Weight g
72440.W0004	Threaded Bush	17	M 4	13	15	8	-	8	6
72440.W0005	Threaded Bush	17	M 5	13	15	8	-	8	6
72440.W0006	Threaded Bush	17	M 6	13	15	8	-	8	6
72440.W0105	Grub Screw, Phillips	17	M 5	13	15	8	20	-	9
72440.W0410	Grub Screw	17	M 4	13	15	8	10	-	4
72440.W0425	Grub Screw	17	M 4	13	15	8	25	-	5
72440.W0515	Grub Screw	17	M 5	13	15	8	15	-	6

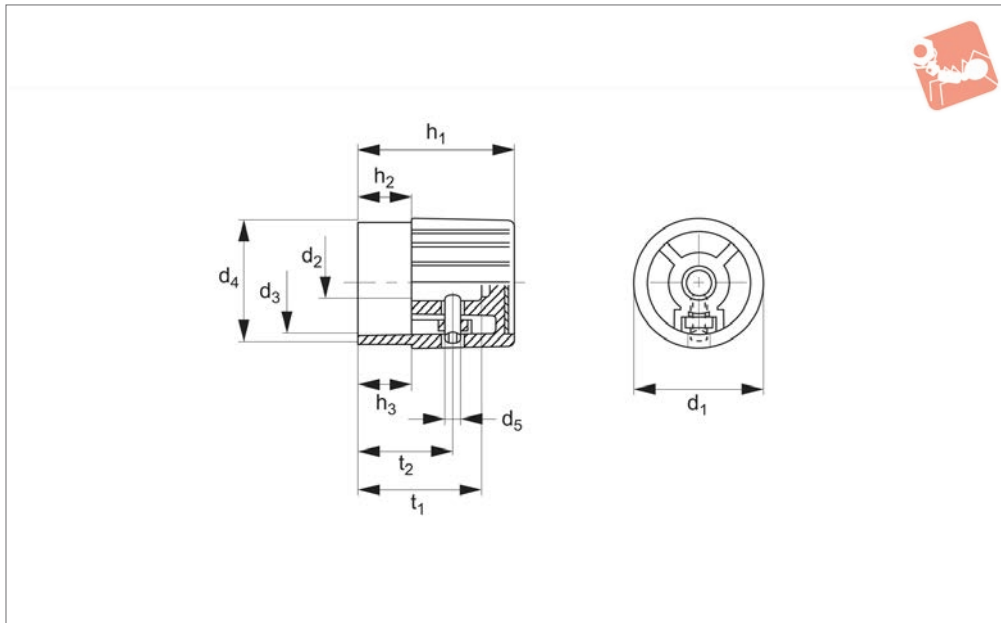

72480

GRIPS

Material

Thermoplastic, black, matt.
Reinforced glass fibre.

Aluminium cover disk.

Technical Notes

Tapped hole with grub screw for mounting

to shaft. „With Index“ model has laser marked index point on diameter.

Order No.	Type	d ₁	d ₂	d ₃	d ₄	d ₅	h ₁	h ₂	h ₃	t ₁	t ₂	Weight g
72480.W0002	W/o Index	27	6	22	25	M 4	30	12	12	25	18	10
72480.W0004	W/o Index	32	8	25	30	M 4	38	13	13	30	23	22
72480.W0006	W/o Index	35	10	28	33	M 5	45	15	15	37	27	30
72480.W0102	With Index	27	6	22	25	M 4	30	12	12	25	18	12
72480.W0104	With Index	32	8	25	30	M 4	38	13	13	30	23	22
72480.W0106	With Index	35	10	28	33	M 5	45	15	15	37	27	30

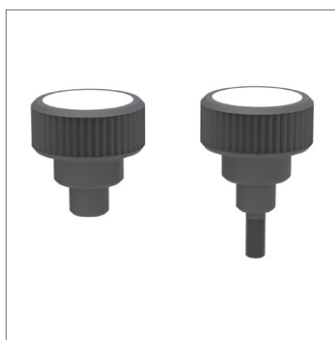

72485

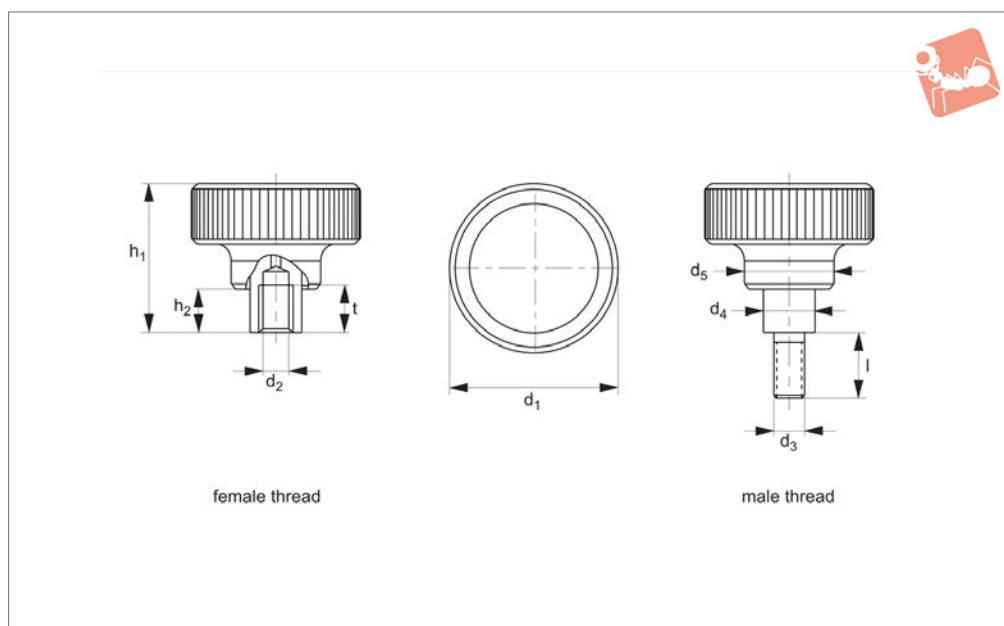
**Material**

Cap: thermoplastic PA 6, light grey, similar to RAL 7035

Torque mechanism: Steel, hardened.

Body: Aluminium, black anodised

Inner part: Steel, blackened

Technical Notes

The handle with intergrate torque

mechanism allows a defined torque during tightening. Reaching the torque results in a „over-looking“. For releasing the torque is transmitted indefinitely.

Order No.	Type	d ₁	d ₂	d ₃	d ₄	d ₅	h ₁	h ₂	l	t	Tightening torque Nm ±10% max.	Weight g
72485.W0020	Female	34	M 3	-	10	21	37.5	9.5	-	7	1.0	48
72485.W0022	Female	34	M 4	-	10	21	37.5	9.5	-	9	1.0	48
72485.W0024	Female	34	M 5	-	10	21	37.5	9.5	-	9	1.0	48
72485.W0026	Female	34	M 6	-	10	21	37.5	9.5	-	9	1.0	48
72485.W0030	Female	42	M 6	-	13.5	27	43.5	11.5	-	11	2.0	127
72485.W0032	Female	42	M8	-	13.5	27	43.5	11.5	-	11	2.0	127
72485.W0040	Female	52	M10	-	19	32	54	15.5	-	17	3.0	206
72485.W0042	Female	52	M12	-	19	32	54	15.5	-	17	3	206
72485.W0050	Female	62	M10	-	19	33	54	15.5	-	17	4	285
72485.W0052	Female	62	M12	-	19	33	54	15.5	-	17	4	285
72485.W0060	Female	62	M10	-	19	33	54	15.5	-	17	5.5	285
72485.W0062	Female	62	M12	-	19	33	54	15.5	-	17	5.5	285
72485.W0300	Male	34	-	M 5	10	21	37.5	9.5	12	-	1.0	62
72485.W0301	Male	34	-	M 5	10	21	37.5	9.5	16	-	1.0	63
72485.W0302	Male	34	-	M 5	10	21	37.5	9.5	20	-	1.0	63
72485.W0303	Male	34	-	M 5	10	21	37.5	9.5	25	-	1.0	64
72485.W0304	Male	34	-	M 5	10	21	37.5	9.5	32	-	1.0	65
72485.W0305	Male	34	-	M 6	10	21	37.5	9.5	12	-	1.0	64
72485.W0306	Male	34	-	M 6	10	21	37.5	9.5	16	-	1.0	65
72485.W0307	Male	34	-	M 6	10	21	37.5	9.5	20	-	1.0	66
72485.W0308	Male	34	-	M 5	10	21	37.5	9.5	12	-	1.0	67
72485.W0309	Male	34	-	M 6	10	21	37.5	9.5	32	-	1.0	68
72485.W0400	Male	42	-	M 8	13.5	27	43.5	11.5	16	-	2.0	152
72485.W0401	Male	42	-	M 8	13.5	27	43.5	11.5	20	-	2.0	153
72485.W0402	Male	42	-	M 8	13.5	27	43.5	11.5	25	-	2.0	155
72485.W0403	Male	42	-	M 8	13.5	27	43.5	11.5	32	-	2.0	158
72485.W0404	Male	42	-	M 8	13.5	27	43.5	11.5	40	-	2.0	161
72485.W0405	Male	42	-	M10	13.5	27	43.5	11.5	20	-	2.0	165
72485.W0406	Male	42	-	M10	13.5	27	43.5	11.5	25	-	2.0	170
72485.W0407	Male	42	-	M10	13.5	27	43.5	11.5	32	-	2.0	173
72485.W0408	Male	42	-	M 10	13.5	27	43.5	11.5	40	-	2.0	62
72485.W0409	Male	42	-	M10	13.5	27	43.5	11.5	50	-	2.0	187



Torque Control Knob

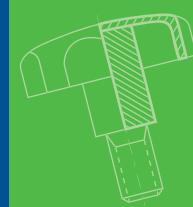

Grips

Order No.	Type	d ₁	d ₂	d ₃	d ₄	d ₅	h ₁	h ₂	l	t	Tightening torque Nm ±10% max.	Weight g
72485.W0500	Male	52	-	M10	19	32	54	15.5	25	-	3.0	241
72485.W0501	Male	52	-	M10	19	32	54.0	15.5	32	-	3.0	62
72485.W0502	Male	52	-	M10	19	32	54.0	15.5	40	-	3.0	248
72485.W0503	Male	52	-	M10	19	32	54.0	15.5	50	-	3.0	254
72485.W0504	Male	52	-	M10	19	32	54.0	15.5	63	-	3.0	262
72485.W0505	Male	52	-	M12	19	32	54.0	15.5	32	-	3.0	251
72485.W0506	Male	34	-	M12	19	32	54.0	15.5	25	-	3.0	254
72485.W0507	Male	52	-	M12	19	32	54.0	15.5	40	-	3.0	262
72485.W0508	Male	52	-	M12	19	32	54.0	15.5	50	-	3.0	270
72485.W0509	Male	52	-	M12	19	32	54.0	15.5	63	-	3.0	274
72485.W0600	Male	62	-	M10	19	33	54.0	15.5	25	-	4.0	334
72485.W0601	Male	62	-	M10	19	33	54.0	15.5	32	-	4.0	339
72485.W0602	Male	62	-	M10	19	33	54.0	15.5	40	-	4.0	341
72485.W0603	Male	62	-	M10	19	33	54.0	15.5	50	-	4.0	347
72485.W0604	Male	62	-	M10	19	33	54.0	15.5	63	-	4.0	355
72485.W0605	Male	62	-	M12	19	33	54.0	15.5	25	-	4.0	344
72485.W0606	Male	62	-	M12	19	33	54.0	15.5	25	-	4.0	347
72485.W0607	Male	62	-	M12	19	33	54.0	15.5	40	-	4.0	355
72485.W0608	Male	62	-	M12	19	33	54.0	15.5	50	-	4.0	363
72485.W0609	Male	62	-	M12	19	33	54.0	15.5	50	-	4.0	367
72485.W0700	Male	62	-	M10	19	33	54.0	15.5	25	-	5.5	334
72485.W0701	Male	62	-	M10	19	33	54.0	15.5	32	-	4.0	339
72485.W0702	Male	62	-	M10	19	33	54.0	15.5	40	-	5.5	334
72485.W0703	Male	62	-	M10	19	33	54.0	15.5	25	-	5.5	347
72485.W0704	Male	62	-	M10	19	33	54.0	15.5	63	-	5.5	355
72485.W0705	Male	62	-	M12	19	33	54.0	15.5	25	-	5.5	344
72485.W0706	Male	52	-	M12	19	33	54.0	15.5	32	-	4.0	347
72485.W0707	Male	62	-	M12	19	33	54.0	15.5	40	-	5.5	355
72485.W0708	Male	62	-	M12	19	33	54.0	15.5	50	-	5.5	363
72485.W0709	Male	62	-	M12	19	33	54.0	15.5	63	-	5.5	367

GRIPS

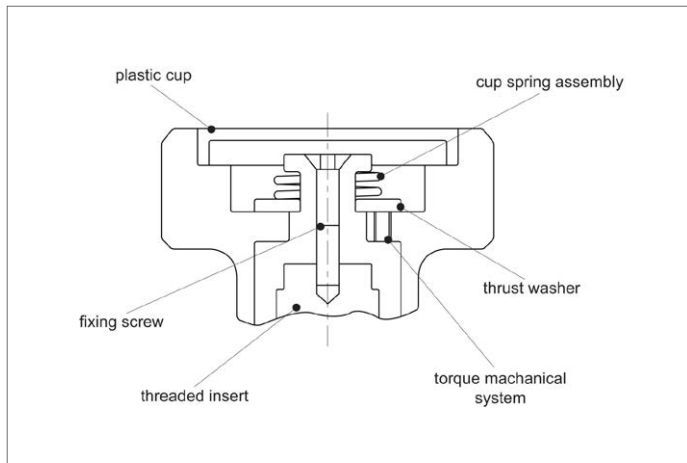

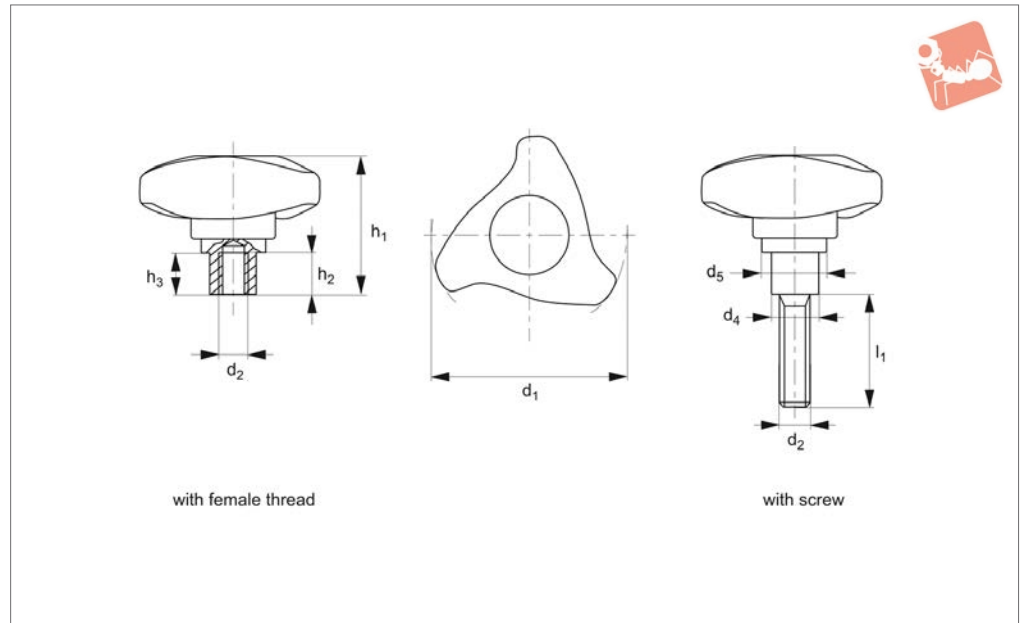

72490

**Material**

Screw: steel, blackened.
 Cap: plastic, light grey.
 Torque mechanism: steel, hardened.
 Inner part: steel, blackened.

mechanism allows a defined torque limitation during tightening.
 Reaching the torque results in an „over-locking“. For releasing the torque is transmitted indefinitely.

Reach: contains SVHC materials > 0,1% w/w.

Technical Notes

The handle with integrated torque

ROHS compliant.

Order No.	Type	d ₁	d ₂	d ₄	d ₅	h ₁	h ₂	h ₃	l ₁	Tightening torque Nm ±10% max.	Weight g
72490.W0020	With female thread	50	M 6	13.5	23.6	41.6	11	10.7	-	2.0	65
72490.W0021	With female thread	50	M 6	13.5	23.6	41.6	11	10.7	-	3.0	62
72490.W0022	With female thread	50	M 6	13.5	23.6	41.6	11	10.7	-	4.0	63
72490.W0023	With female thread	50	M 6	13.5	23.6	41.6	11	10.7	-	2.0	60
72490.W0024	With female thread	50	M 8	13.5	23.6	41.6	11	10.7	-	3.0	60
72490.W0025	With female thread	50	M 8	13.5	23.6	41.6	11	10.7	-	4.0	64
72490.W0030	With female thread	63	M 8	16.0	28.1	46.6	14	12.9	-	3.2	104
72490.W0031	With female thread	63	M 8	16.0	28.1	46.6	14	12.9	-	4.0	105
72490.W0032	With female thread	63	M 8	16.0	28.1	46.6	14	12.9	-	4.7	107
72490.W0033	With female thread	63	M10	16.0	28.1	46.6	14	12.9	-	3.2	103
72490.W0034	With female thread	63	M10	16.0	28.1	46.6	14	12.9	-	4.0	102
72490.W0035	With female thread	63	M10	16.0	28.1	46.6	14	12.9	-	4.7	103
72490.W0040	With female thread	80	M10	19.0	34.1	56.2	17	16.8	-	4.0	172
72490.W0041	With female thread	80	M10	19.0	34.1	56.2	17	16.8	-	5.5	173
72490.W0042	With female thread	80	M10	19.0	34.1	56.2	17	16.8	-	7.5	174
72490.W0043	With female thread	80	M12	19.0	34.1	56.2	17	16.8	-	4.0	167
72490.W0044	With female thread	80	M12	19.0	34.1	56.2	17	16.8	-	5.5	168
72490.W0045	With female thread	80	M12	19.0	34.1	56.2	17	16.8	-	7.5	171
72490.W0300	With screw	50	M 8	13.5	23.6	41.6	-	10.7	16	2.0	72
72490.W0301	With screw	50	M 8	13.5	23.6	41.6	-	10.7	16	3.0	75
72490.W0302	With screw	50	M 8	13.5	23.6	41.6	-	10.7	16	4.0	76
72490.W0303	With screw	50	M 8	13.5	23.6	41.6	-	10.7	20	2.0	70
72490.W0304	With screw	50	M 8	13.5	23.6	41.6	-	10.7	20	3.0	73
72490.W0305	With screw	50	M 8	13.5	23.6	41.6	-	10.7	20	4.0	71
72490.W0306	With screw	50	M 8	13.5	23.6	41.6	-	10.7	25	2.0	72
72490.W0307	With screw	50	M 8	13.5	23.6	41.6	-	10.7	25	3.0	72
72490.W0308	With screw	50	M 8	13.5	23.6	41.6	-	10.7	25	4.0	73
72490.W0309	With screw	50	M 8	13.5	23.6	41.6	-	10.7	32	2.0	77
72490.W0310	With screw	50	M 8	13.5	23.6	41.6	-	10.7	32	3.0	74



Three-lobed Torque Handles

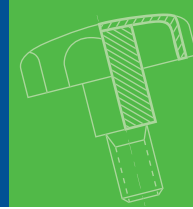

Grips

Order No.	Type	d ₁	d ₂	d ₄	d ₅	h ₁	h ₂	h ₃	l ₁	Tightening torque Nm ±10% max.	Weight g
72490.W0311	With screw	50	M 8	13.5	23.6	41.6	–	10.7	32	4.0	75
72490.W0312	With screw	50	M 8	13.5	23.6	41.6	–	10.7	40	2.0	76
72490.W0313	With screw	50	M 8	13.5	23.6	41.6	–	10.7	40	3.0	76
72490.W0314	With screw	50	M 8	13.5	23.6	41.6	–	10.7	40	4.0	77
72490.W0315	With screw	50	M10	13.5	23.6	41.6	–	10.7	20	2.0	73
72490.W0316	With screw	50	M10	13.5	23.6	41.6	–	10.7	20	3.0	73
72490.W0317	With screw	50	M10	13.5	23.6	41.6	–	10.7	20	4.0	74
72490.W0318	With screw	50	M10	13.5	23.6	41.6	–	10.7	25	2.0	76
72490.W0319	With screw	50	M10	13.5	23.6	41.6	–	10.7	25	3.0	76
72490.W0320	With screw	50	M10	13.5	23.6	41.6	–	10.7	25	4.0	77
72490.W0321	With screw	50	M10	13.5	23.6	41.6	–	10.7	32	2.0	80
72490.W0322	With screw	50	M10	13.5	23.6	41.6	–	10.7	32	3.0	80
72490.W0323	With screw	50	M10	13.5	23.6	41.6	–	10.7	32	4.0	81
72490.W0324	With screw	50	M10	13.5	23.6	41.6	–	10.7	40	2.0	82
72490.W0325	With screw	50	M10	13.5	23.6	41.6	–	10.7	40	3.0	82
72490.W0326	With screw	50	M10	13.5	23.6	41.6	–	10.7	40	4.0	83
72490.W0327	With screw	50	M10	13.5	23.6	41.6	–	10.7	50	2.0	87
72490.W0328	With screw	50	M10	13.5	23.6	41.6	–	10.7	50	3.0	87
72490.W0329	With screw	50	M10	13.5	23.6	41.6	–	10.7	50	4.0	88
72490.W0400	With screw	63	M 8	16.0	28.1	46.6	–	12.9	25	3.2	116
72490.W0401	With screw	63	M 8	16.0	28.1	46.6	–	12.9	25	4.0	117
72490.W0402	With screw	63	M 8	16.0	28.1	46.6	–	12.9	25	4.7	118
72490.W0403	With screw	63	M 8	16.0	28.1	46.6	–	12.9	32	3.2	119
72490.W0404	With screw	63	M 8	16.0	28.1	46.6	–	12.9	32	4.0	120
72490.W0405	With screw	63	M 8	16.0	28.1	46.6	–	12.9	32	4.7	121
72490.W0406	With screw	63	M 8	16.0	28.1	46.6	–	12.9	40	3.2	82
72490.W0407	With screw	63	M 8	16.0	28.1	46.6	–	12.9	40	4.0	83
72490.W0408	With screw	63	M 8	16.0	28.1	46.6	–	12.9	40	4.7	83
72490.W0409	With screw	63	M 8	16.0	28.1	46.6	–	12.9	50	3.2	128
72490.W0410	With screw	63	M 8	16.0	28.1	46.6	–	12.9	50	4.0	127
72490.W0411	With screw	63	M 8	16.0	28.1	46.6	–	12.9	50	4.7	128
72490.W0412	With screw	63	M 8	16.0	28.1	46.6	–	12.9	63	3.2	130
72490.W0413	With screw	63	M 8	16.0	28.1	46.6	–	12.9	63	4.0	131
72490.W0414	With screw	63	M 8	16.0	28.1	46.6	–	12.9	63	4.7	132
72490.W0415	With screw	63	M10	16.0	28.1	46.6	–	12.9	25	3.2	122
72490.W0416	With screw	63	M10	16.0	28.1	46.6	–	12.9	25	4.0	123
72490.W0417	With screw	63	M10	16.0	28.1	46.6	–	12.9	25	4.7	124
72490.W0418	With screw	63	M10	16.0	28.1	46.6	–	12.9	32	3.2	125
72490.W0419	With screw	63	M10	16.0	28.1	46.6	–	12.9	32	4.0	126
72490.W0420	With screw	63	M10	16.0	28.1	46.6	–	12.9	32	4.7	127
72490.W0421	With screw	63	M10	16.0	28.1	46.6	–	12.9	40	3.2	129
72490.W0422	With screw	63	M10	16.0	28.1	46.6	–	12.9	40	4.0	130
72490.W0423	With screw	63	M10	16.0	28.1	46.6	–	12.9	40	4.7	131
72490.W0424	With screw	63	M10	16.0	28.1	46.6	–	12.9	50	3.2	134
72490.W0425	With screw	63	M10	16.0	28.1	46.6	–	12.9	50	4.0	135
72490.W0426	With screw	63	M10	16.0	28.1	46.6	–	12.9	50	4.7	136
72490.W0427	With screw	63	M10	16.0	28.1	46.6	–	12.9	63	3.2	140
72490.W0428	With screw	63	M10	16.0	28.1	46.6	–	12.9	63	4.0	141
72490.W0429	With screw	63	M10	16.0	28.1	46.6	–	12.9	63	4.7	142
72490.W0500	With screw	80	M10	19.0	34.1	56.2	–	16.8	25	4.0	194
72490.W0501	With screw	80	M10	19.0	34.1	56.2	–	16.8	25	5.5	195
72490.W0502	With screw	80	M10	19.0	34.1	56.2	–	16.8	25	7.5	196
72490.W0503	With screw	80	M10	19.0	34.1	56.2	–	16.8	32	4.0	198
72490.W0504	With screw	80	M10	19.0	34.1	56.2	–	16.8	32	5.5	199
72490.W0505	With screw	80	M10	19.0	34.1	56.2	–	16.8	32	7.5	200
72490.W0506	With screw	80	M10	19.0	34.1	56.2	–	16.8	40	4.0	202
72490.W0507	With screw	80	M10	19.0	34.1	56.2	–	16.8	40	5.5	203
72490.W0508	With screw	80	M10	19.0	34.1	56.2	–	16.8	40	7.5	204
72490.W0509	With screw	80	M10	19.0	34.1	56.2	–	16.8	50	4.0	208
72490.W0510	With screw	80	M10	19.0	34.1	56.2	–	16.8	50	5.5	209
72490.W0511	With screw	80	M10	19.0	34.1	56.2	–	16.8	50	7.5	210
72490.W0512	With screw	80	M10	19.0	34.1	56.2	–	16.8	63	4.0	213
72490.W0513	With screw	80	M10	19.0	34.1	56.2	–	16.8	63	5.5	214
72490.W0514	With screw	80	M10	19.0	34.1	56.2	–	16.8	63	7.5	215
72490.W0515	With screw	80	M12	19.0	34.1	56.2	–	16.8	25	4.0	201
72490.W0516	With screw	80	M12	19.0	34.1	56.2	–	16.8	25	5.5	202
72490.W0517	With screw	80	M12	19.0	34.1	56.2	–	16.8	25	7.5	203

GRIPS



Order No.	Type	d ₁	d ₂	d ₄	d ₅	h ₁	h ₂	h ₃	l ₁	Tightening torque Nm ±10% max.	Weight g
72490.W0518	With screw	80	M12	19.0	34.1	56.2	–	16.8	32	4.0	205
72490.W0519	With screw	80	M12	19.0	34.1	56.2	–	16.8	32	5.5	206
72490.W0520	With screw	80	M12	19.0	34.1	56.2	–	16.8	32	7.5	207
72490.W0521	With screw	80	M12	19.0	34.1	56.2	–	16.8	40	4.0	210
72490.W0522	With screw	80	M12	19.0	34.1	56.2	–	16.8	40	5.5	211
72490.W0523	With screw	80	M12	19.0	34.1	56.2	–	16.8	40	7.5	212
72490.W0524	With screw	80	M12	19.0	34.1	56.2	–	16.8	50	4.0	218
72490.W0525	With screw	80	M12	19.0	34.1	56.2	–	16.8	50	5.5	219
72490.W0526	With screw	80	M12	19.0	34.1	56.2	–	16.8	50	7.5	220
72490.W0527	With screw	80	M12	19.0	34.1	56.2	–	16.8	63	4.0	227
72490.W0528	With screw	80	M12	19.0	34.1	56.2	–	16.8	63	5.5	228
72490.W0529	With screw	80	M12	19.0	34.1	56.2	–	16.8	63	7.5	229



Quarter Turn Screw, Male

stainless steel

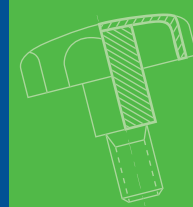

Grips

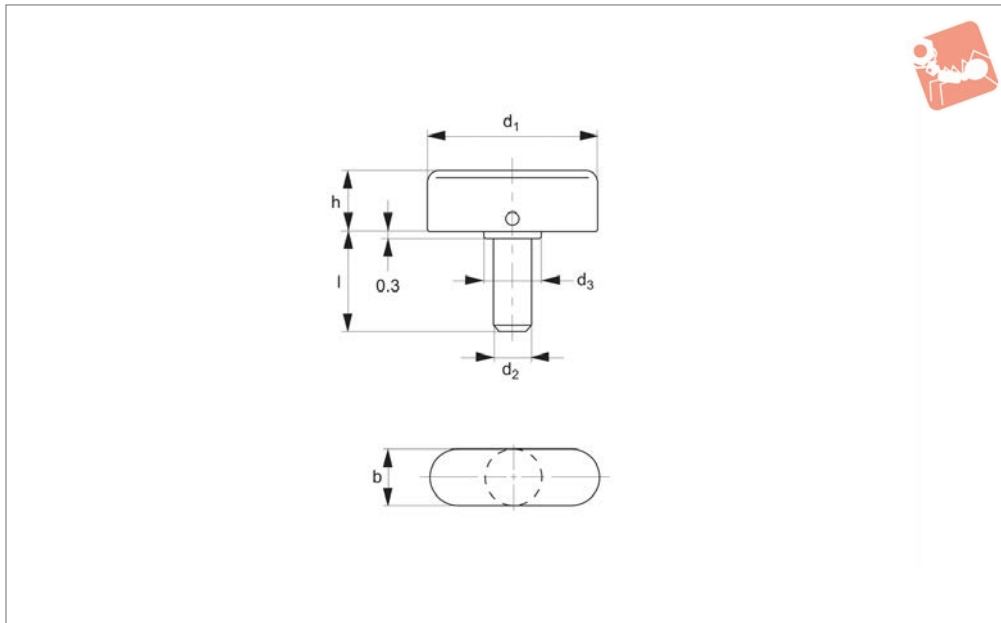

37380

GRIPS

Material

Stainless steel 1.4404 (AISI 316), body sintered, matte, shot-blasted. Screw: stainless steel, 1.4301 (AISI 304), matte,

shot-blasted.

Technical Notes

These quarter turn screws are used to

develop higher clamping torques than is possible with knurled handles.

Order No.	d ₁	d ₂	d ₃	b	h	l	Weight g
37380.W0061	25	M 6	8	8	10.0	16	12
37380.W0062	25	M 6	8	8	10.0	20	16
37380.W0063	25	M 6	8	8	10.0	25	10
37380.W0081	30	M 8	10	10	12.0	16	26
37380.W0082	30	M 8	10	10	12.0	20	28
37380.W0083	30	M 8	10	10	12.0	25	30
37380.W0084	30	M 8	10	10	12.0	32	32
37380.W0085	36	M 8	12	12	14.5	16	44
37380.W0086	36	M 8	12	12	14.5	20	45
37380.W0087	36	M 8	12	12	14.5	25	50
37380.W0088	36	M 8	12	12	14.5	32	49
37380.W0101	36	M10	12	12	14.5	20	48
37380.W0102	36	M10	12	12	14.5	30	53
37380.W0103	36	M10	12	12	14.5	40	55



37400

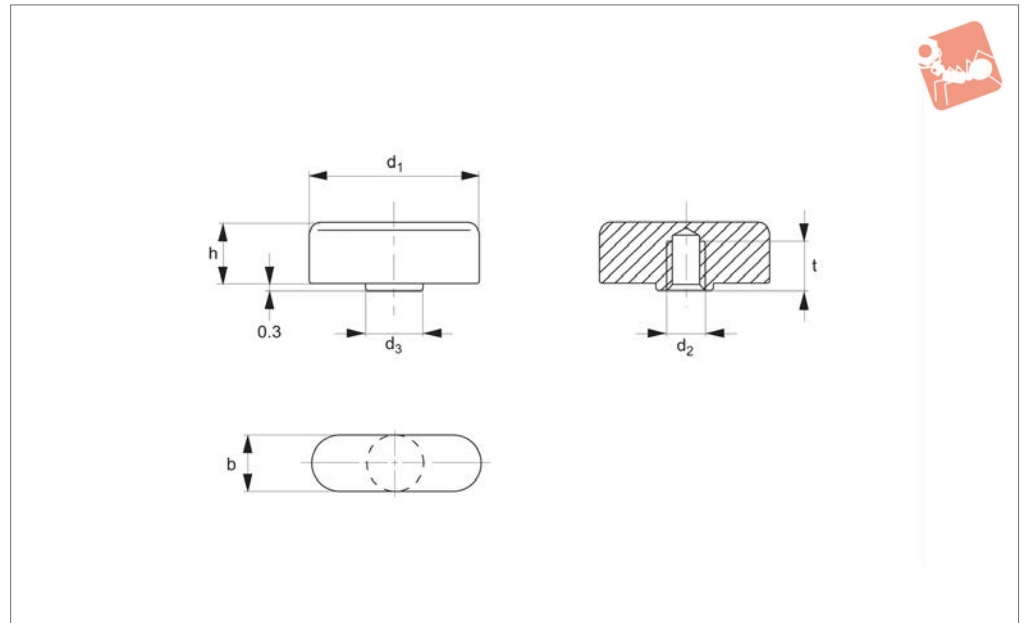

Material

Stainless steel 1.4404 (AISI 316), sintered, matte, shot-blasted.

Technical Notes

These quarter turn screws are used to develop higher clamping torques than is

possible with knurled handles.

Order No.	d_1	d_2	d_3	b	h	t min.	Weight g
37400.W0061	25	M 6	8	8	10.0	7	11
37400.W0062	30	M 6	10	10	12.0	9	18
37400.W0081	30	M 8	10	10	12.0	9	18
37400.W0082	36	M 8	12	12	14.5	10	36
37400.W0101	36	M10	12	12	14.5	10	36

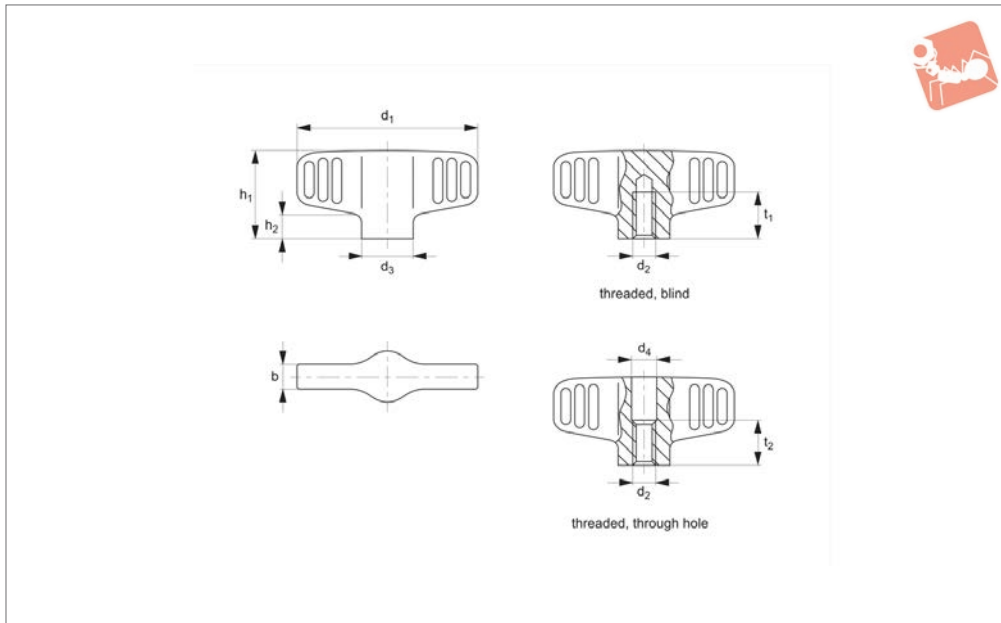
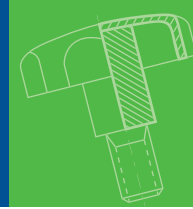

37420

GRIPS

Material

Stainless steel 1.4308, matt finish.

Order No.	Type	d ₁	d ₂	d ₃	d ₄ tol. H13	b	h ₁	h ₂ ≈	t ₁ min.	t ₂
37420.W0010	Threaded, blind	46	M 6	13	6.5	6	22.5	6.0	12	10
37420.W0012	Threaded, blind	46	M 8	13	8.5	6	22.5	6.0	15	13
37420.W0014	Threaded, blind	58	M 8	16	8.5	7	26.5	7.0	15	13
37420.W0016	Threaded, blind	58	M10	16	10.5	7	26.5	7.0	18	16
37420.W0210	Threaded, through hole	46	M 6	13	6.5	6	22.5	6.0	12	10
37420.W0212	Threaded, through hole	46	M 8	13	8.5	6	22.5	6.0	15	13
37420.W0214	Threaded, through hole	58	M 8	16	8.5	7	26.5	7.0	15	13
37420.W0216	Threaded, through hole	58	M10	16	10.5	7	26.5	7.0	18	16



72180 - Plastic wing nut



72190 - Plastic wing nut
with screw



72210 - Plastic wing nuts



72270 - 1/4 turn nut



72280 - 1/4 turn nut



72290 - 1/4 turn screw



72300 - 1/4 turn screw

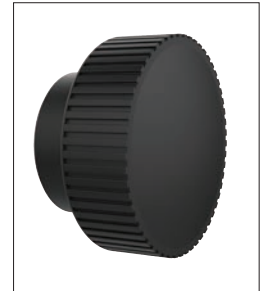

72410 - Knurled knob



72430 - Knurled knob
with screw



72440 - Knurled knobs



72460 - Knurled knobs



73200 - Mushroom knobs

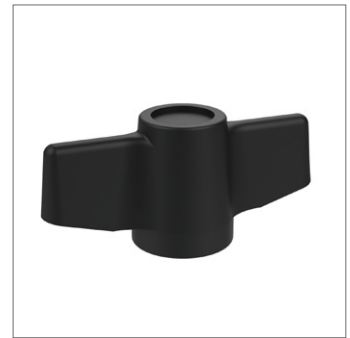
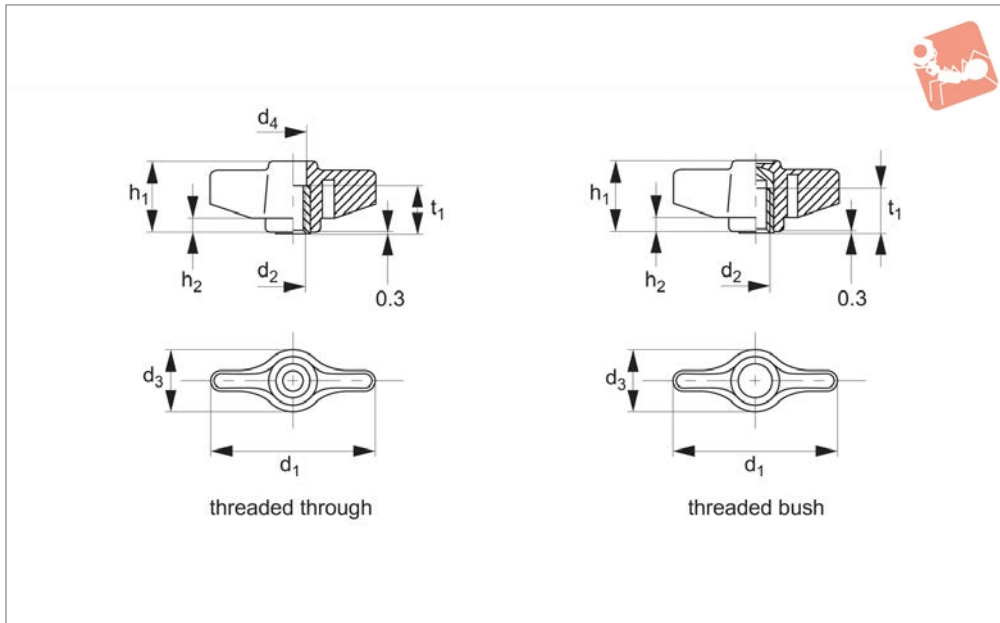
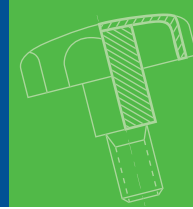

72180

GRIPS

Material

Brass bush. Thermoplastic, black, matte.

Order No.	Type	d ₁	d ₂	d ₃	d ₄	h ₁	h ₂	t ₁	Weight g
72180.W0034	Threaded Through	34	M 5	14	7	18	4	15	7
72180.W0035	Threaded Through	34	M 6	14	7	18	4	15	7
72180.W0040	Threaded Through	40	M 6	15	9	19	4	15	10
72180.W0041	Threaded Through	40	M 8	15	9	19	4	15	10
72180.W0048	Threaded Through	48	M 6	17	9	20	4	15	10
72180.W0049	Threaded Through	48	M 8	17	9	20	4	15	11
72180.W0135	Threaded Bush	34	M 5	14	-	18	4	8	5
72180.W0136	Threaded Bush	34	M 6	14	-	18	4	9	5
72180.W0138	Threaded Bush	34	M 8	14	-	18	4	9	6
72180.W0146	Threaded Bush	40	M 6	15	-	19	4	9	7
72180.W0148	Threaded Bush	40	M 8	15	-	19	4	9	7
72180.W0149	Threaded Bush	48	M 6	17	-	20	4	13	7
72180.W0150	Threaded Bush	48	M 8	17	-	20	4	13	9

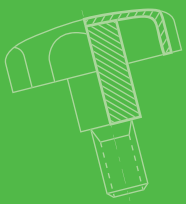

72190

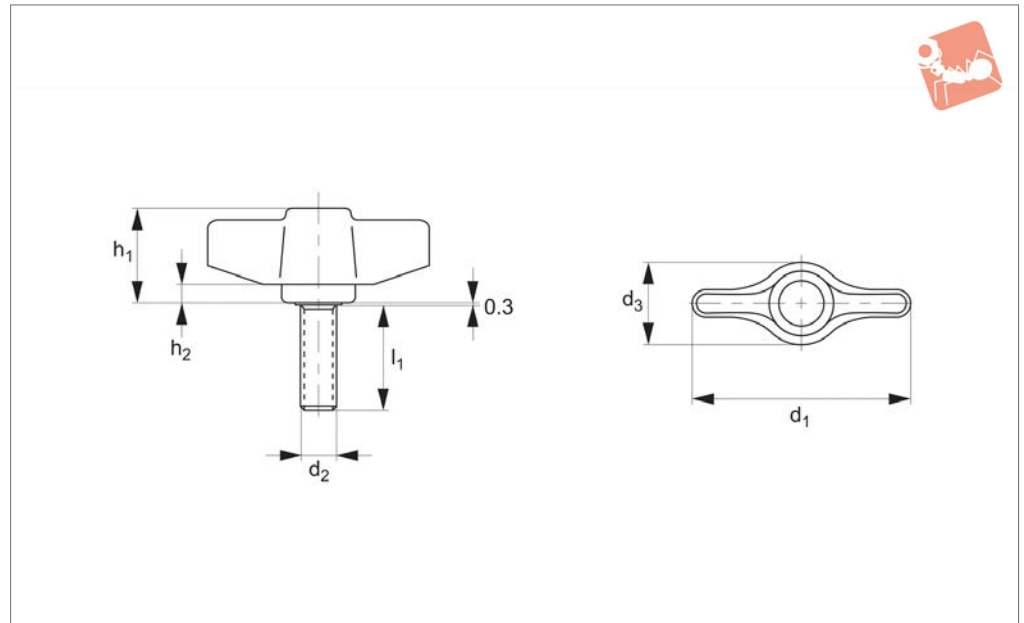

Material

Zinc plated steel stud. Thermoplastic, black, matt.

Order No.	d ₁	d ₂	d ₃	h ₁	h ₂	l ₁	Weight g
72190.W0341	34	M 4	14	18	4	15	5
72190.W0342	34	M 5	14	18	4	15	7
72190.W0343	34	M 6	14	18	4	15	9
72190.W0344	34	M 6	14	18	4	25	11
72190.W0345	34	M 8	14	18	4	15	13
72190.W0346	34	M 8	14	18	4	25	15
72190.W0401	40	M 6	15	19	4	15	10
72190.W0402	40	M 6	15	19	4	20	11
72190.W0403	40	M 8	15	19	4	15	14
72190.W0404	40	M 8	15	19	4	20	15
72190.W0405	40	M 8	15	19	4	25	16
72190.W0481	48	M 6	17	20	4	15	12
72190.W0482	48	M 6	17	20	4	20	12
72190.W0483	48	M 6	17	20	4	25	13
72190.W0484	48	M 8	17	20	4	15	15
72190.W0485	48	M 8	17	20	4	25	18
72190.W0486	48	M 8	17	20	4	30	19
72190.W0487	48	M 8	17	20	4	40	22

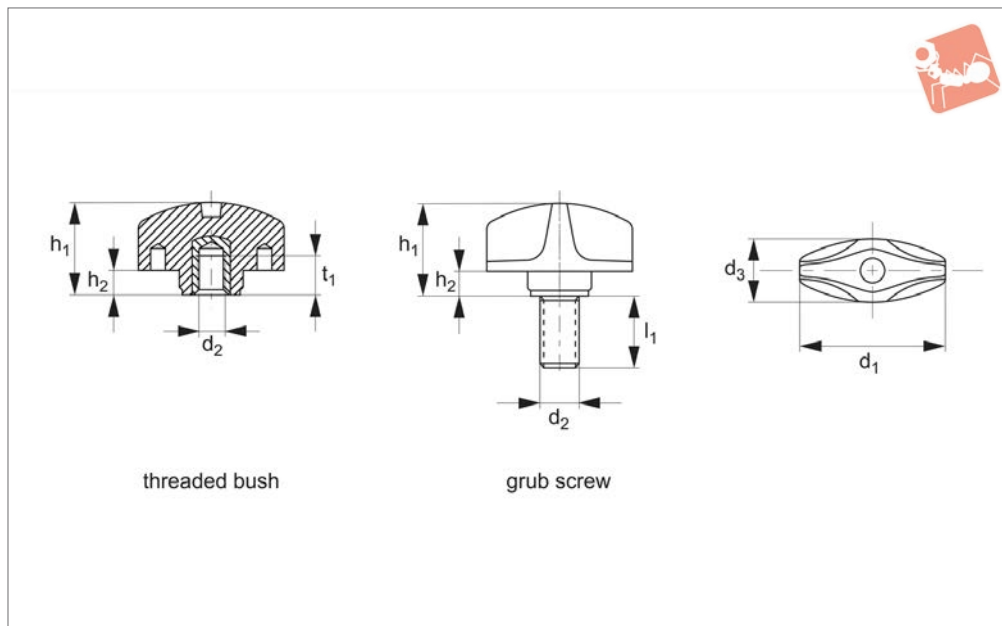
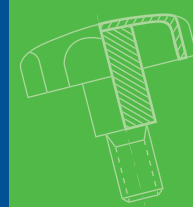

72210

GRIPS

Material

Brass bush. Zinc plated steel stud. Thermo-plastic, black, matt.

Order No.	Type	d ₁	d ₂	d ₃	h ₁	h ₂	l ₁	t ₁	Weight g
72210.W0004	Threaded Bush	30	M 4	13	19	5	-	8	5.8
72210.W0005	Threaded Bush	30	M 5	13	19	5	-	8	5.4
72210.W0006	Threaded Bush	30	M 6	13	19	5	-	8	5.6
72210.W0008	Threaded Bush	30	M 8	13	19	5	-	8	6.0
72210.W0341	Grub Screw	30	M 4	13	19	5	15	-	5.4
72210.W0342	Grub Screw	30	M 4	13	19	5	20	-	5.4
72210.W0351	Grub Screw	30	M 5	13	19	5	15	-	6.4
72210.W0352	Grub Screw	30	M 5	13	19	5	25	-	7.6
72210.W0353	Grub Screw	30	M 5	13	19	5	30	-	9.4
72210.W0361	Grub Screw	30	M 6	13	19	5	15	-	8.0
72210.W0362	Grub Screw	30	M 6	13	19	5	25	-	9.8
72210.W0363	Grub Screw	30	M 6	13	19	5	30	-	10.0
72210.W0364	Grub Screw	30	M 6	13	19	5	40	-	12.2
72210.W0381	Grub Screw	30	M 8	13	19	5	15	-	11.4
72210.W0383	Grub Screw	30	M 8	13	19	5	30	-	16.6
72210.W0384	Grub Screw	30	M 8	13	19	5	40	-	19.8

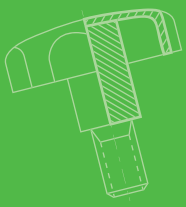

72270

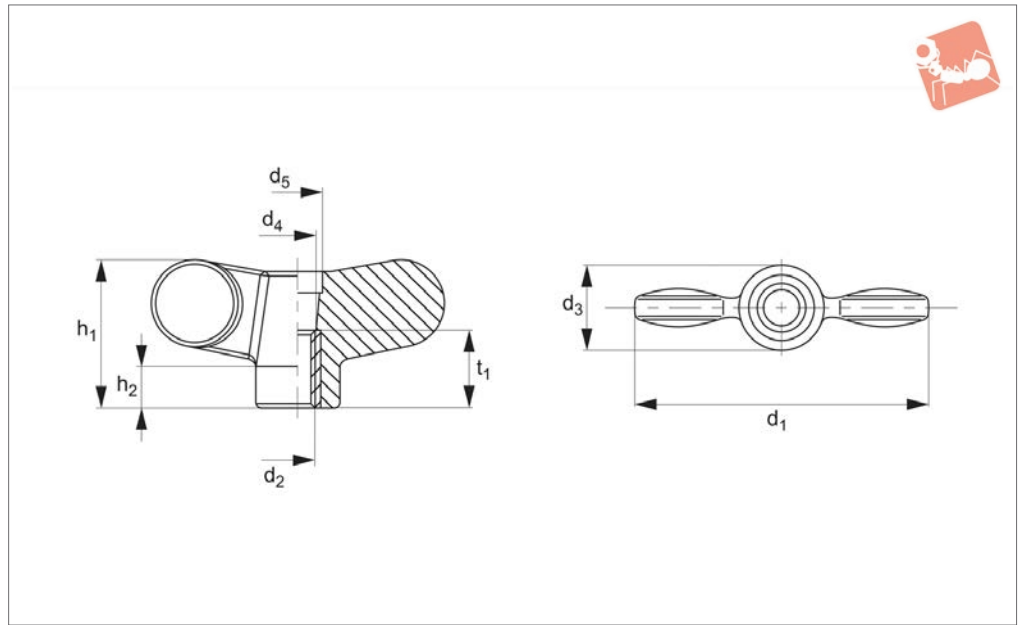

Material

Thermoplastic, black.
Brass bush.

Order No.	d ₁	d ₂	d ₃	d ₄	d ₅	h ₁	h ₂	t ₁	Weight g
72270.W0052	55	M 6	16	8	11	28	8	18	14
72270.W0054	55	M 8	16	10	11	28	8	18	15
72270.W0074	70	M 8	20	10	11	36	10	18	23
72270.W0076	70	M10	20	11	11	36	10	18	24



Wing Nut

plastic, with colour insert

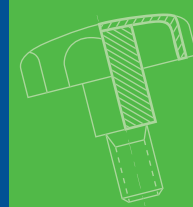

Grips

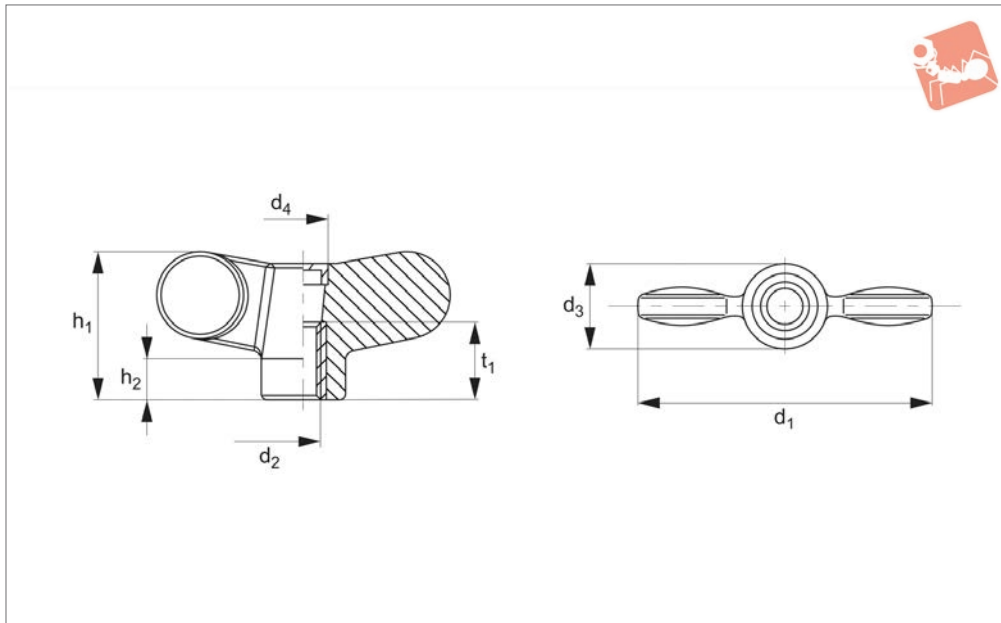

72280

GRIPS

Material

Thermoplastic, black.
Plastic insert: black RAL9005, red

RAL3000, blue RAL5019.

subject to minimum quantity.

Tips

Other colour inserts available on request,

Order No.	Insert colour	d ₁	d ₂	d ₃	d ₄	h ₁	h ₂	t ₁	Weight g
72280.W0052	Black	55	M 6	16	11	28	8	18	14.5
72280.W0054	Black	55	M 8	16	11	28	8	18	15.5
72280.W0074	Black	70	M 8	20	11	36	10	18	23.5
72280.W0076	Black	70	M10	20	11	36	10	18	24.5
72280.W0152	Red	55	M 6	16	11	28	8	18	14.5
72280.W0154	Red	55	M 8	16	11	28	8	18	15.5
72280.W0174	Red	70	M 8	20	11	36	10	18	23.5
72280.W0176	Red	70	M10	20	11	36	10	18	24.5
72280.W0252	Blue	55	M 6	16	11	28	8	18	14.5
72280.W0254	Blue	55	M 8	16	11	28	8	18	15.5
72280.W0274	Blue	70	M 8	20	11	36	10	18	23.5
72280.W0276	Blue	70	M10	20	11	36	10	18	24.5



Wing Nut

plastic, with grub screw and colour insert



72290

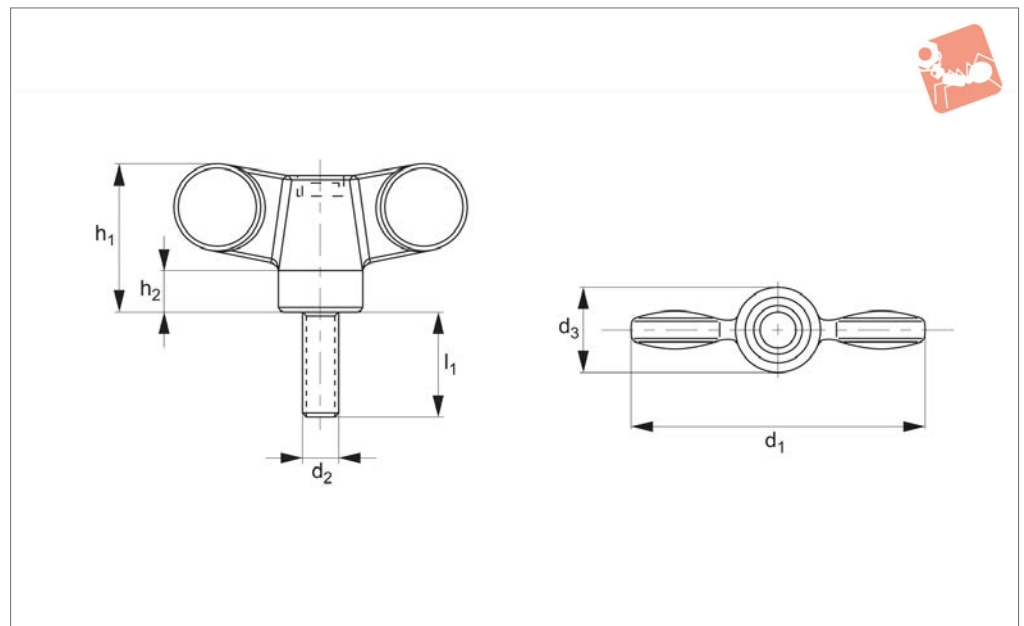

Material

Thermoplastic black.

Plastic insert: black RAL9005, red

RAL3000, blue RAL 5019.

subject to minimum quantity.

Tips

Other colour inserts available on request,

Order No.	Insert colour	d ₁	d ₂	d ₃	h ₁	h ₂	l ₁	Weight g
72290.W0054	Black	55	M 8	16	28	8	20	24
72290.W0055	Black	55	M 8	16	28	8	40	26
72290.W0056	Black	55	M10	16	28	8	20	30
72290.W0057	Black	55	M10	16	28	8	40	40
72290.W0074	Black	70	M 8	20	36	10	20	30
72290.W0076	Black	70	M10	20	36	10	20	39
72290.W0077	Black	70	M10	20	36	10	40	47
72290.W0154	Red	55	M 8	16	28	8	20	24
72290.W0155	Red	55	M 8	16	28	8	40	26
72290.W0156	Red	55	M10	16	28	8	20	30
72290.W0157	Red	55	M10	16	28	8	40	40
72290.W0174	Red	70	M 8	20	36	10	20	30
72290.W0176	Red	70	M10	20	36	10	20	39
72290.W0177	Red	70	M10	20	36	10	40	47
72290.W0254	Blue	55	M 8	16	28	8	20	24
72290.W0255	Blue	55	M 8	16	28	8	40	26
72290.W0256	Blue	55	M10	16	28	8	20	30
72290.W0257	Blue	55	M10	16	28	8	40	40
72290.W0274	Blue	70	M 8	20	36	10	20	30
72290.W0276	Blue	70	M10	20	36	10	20	39
72290.W0277	Blue	70	M10	20	36	10	40	47



Wing Nut - Stainless Steel plastic, with grub screw and colour insert

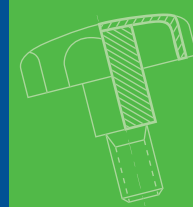

Grips

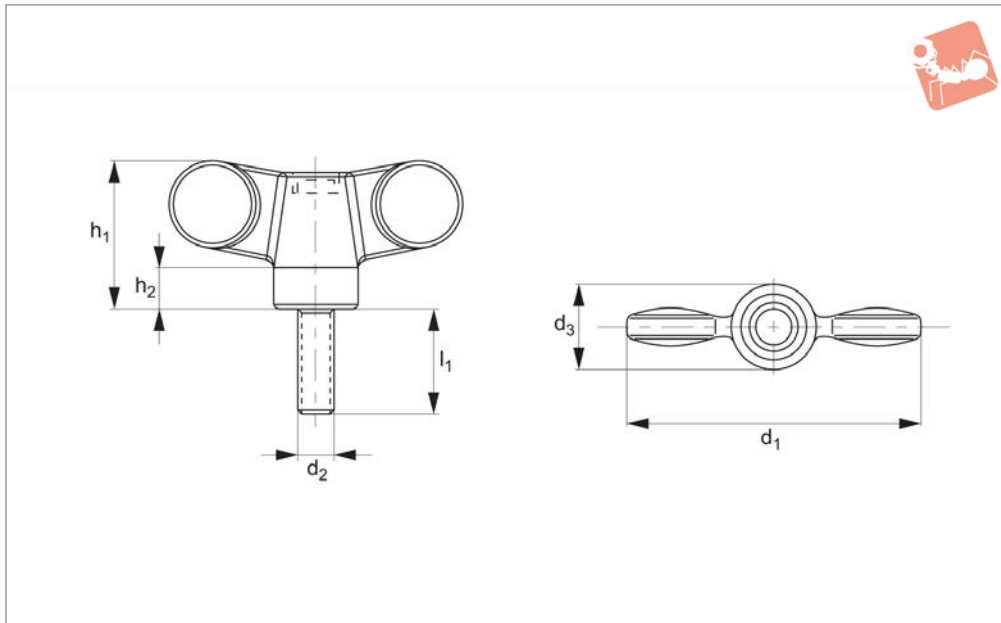

72300

GRIPS

Material

Thermoplastic black, with stainless steel thread.

Plastic insert: black RAL9005, red

RAL3000, blue RAL5019.

subject to minimum quantity.

Tips

Other colour inserts available on request,

Order No.	Insert colour	d ₁	d ₂	d ₃	h ₁	h ₂	l ₁	Weight g
72300.W0054	Black	55	M 8	16	28	8	20	24
72300.W0055	Black	55	M 8	16	28	8	30	25
72300.W0077	Black	70	M10	20	36	10	30	43
72300.W0154	Red	55	M 8	16	28	8	20	24
72300.W0155	Red	55	M 8	16	28	8	30	25
72300.W0177	Red	70	M10	20	36	10	30	43
72300.W0254	Blue	55	M 8	16	28	8	20	24
72300.W0255	Blue	55	M 8	16	28	8	30	25
72300.W0277	Blue	70	M10	20	36	10	30	43

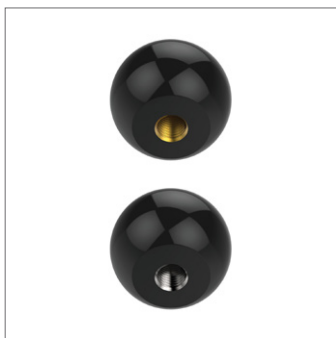

73000

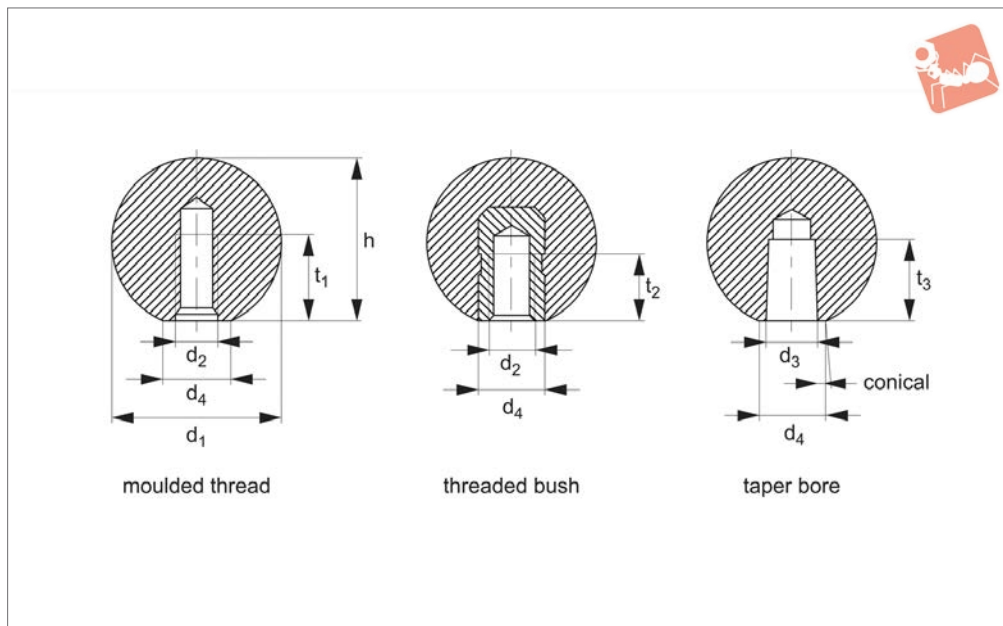

Material

Duroplast PF 31 DIN 7708, black.
Bush: steel, zinc-plated. 73000.W0116 has bush of brass.
Finish: polished, jointless.

Threaded bush type also available in red, subject to minimum quantity.

Technical Notes

Temperature range max. 110°C. Assembly

of taper bush model is through lightly tapping with a hammer, the knob will hold in position without need for cementing. Counter bore requires an h9 fit.

Order No.	Finish	d ₁	d ₂	d ₃	d ₄ ≈	h ≈	t ₁ min.	t ₂ min.	t ₃ min.	Weight g
73000.W0016	Moulded Thread	16	M 4	-	8	15.0	7.0	-	-	3.2
73000.W0020	Moulded Thread	20	M 5	-	12	18.0	9.0	-	-	5.2
73000.W0025	Moulded Thread	25	M 6	-	15	22.5	11.0	-	-	10.0
73000.W0032	Moulded Thread	32	M 8	-	18	29.0	14.0	-	-	22.0
73000.W0040	Moulded Thread	40	M10	-	22	37.0	18.0	-	-	43.0
73000.W0050	Moulded Thread	50	M12	-	28	46.0	21.0	-	-	86.0
73000.W0116	Threaded Bush	16	M 4	-	8	15.0	-	6.0	-	5.1
73000.W0120	Threaded Bush	20	M 5	-	12	18.0	-	7.5	-	6.6
73000.W0125	Threaded Bush	25	M 6	-	15	22.5	-	9.0	-	13.0
73000.W0132	Threaded Bush	32	M 8	-	18	29.0	-	12.0	-	26.0
73000.W0140	Threaded Bush	40	M10	-	22	37.0	-	15.0	-	56.0
73000.W0150	Threaded Bush	50	M12	-	28	46.0	-	18.0	-	108.0
73000.W0216	Taper Bore	16	-	4	8	15.0	-	-	9.0	2.7
73000.W0220	Taper Bore	20	-	5	12	18.0	-	-	12.0	5.1
73000.W0225	Taper Bore	25	-	6	15	22.5	-	-	15.0	9.3
73000.W0232	Taper Bore	32	-	8	18	29.0	-	-	15.0	19.0
73000.W0240	Taper Bore	40	-	10	22	37.0	-	-	20.0	39.0
73000.W0250	Taper Bore	50	-	12	28	46.0	-	-	22.0	84.0



Ball Knobs - Steel

similar to DIN 319



Grips

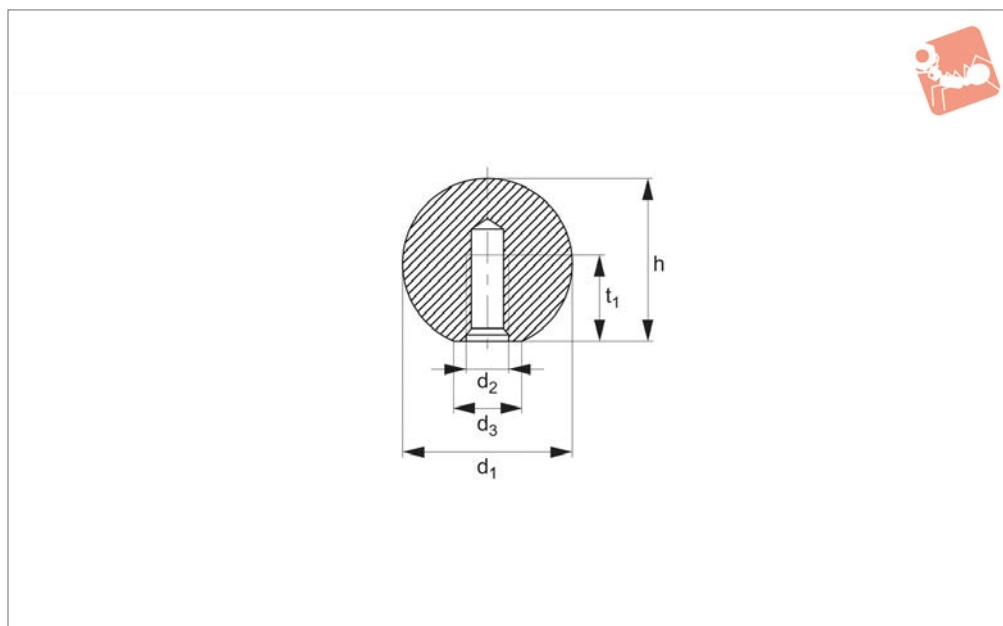

73002

GRIPS

Material

Steel, polished, bright

Order No.	d ₁	d ₂	d ₃ ≈	h ≈	t ₁ min.	Weight g
73002.W0016	16	M 4	8	15.0	7.0	16
73002.W0020	20	M 5	12	18.0	9.0	26
73002.W0025	25	M 6	15	22.5	11.0	58
73002.W0032	32	M 8	18	29.0	14.5	116
73002.W0040	40	M10	22	37.0	18.0	241
73002.W0050	50	M12	27	46.0	21.0	475



73004

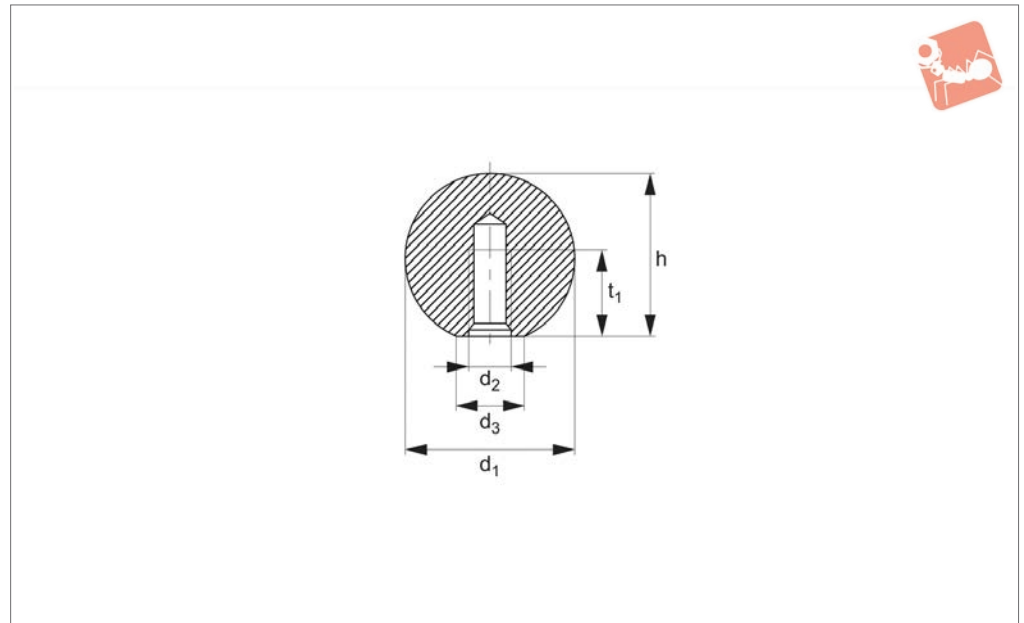

Material

Stainless steel 1.4305, dull blasted

Order No.	d ₁	d ₂	d ₃ ≈	h ≈	t ₁ min.	Weight g
73004.W0216	16	M 4	8	15.0	7.0	16
73004.W0220	20	M 5	12	18.0	9.0	31
73004.W0225	25	M 6	15	22.5	11.0	59
73004.W0232	32	M 8	18	29.0	14.5	122
73004.W0240	40	M10	22	37.0	18.0	242



Ball Knobs - aluminium

similar to DIN 319

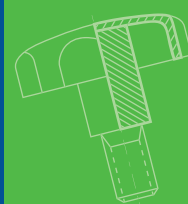

Grips

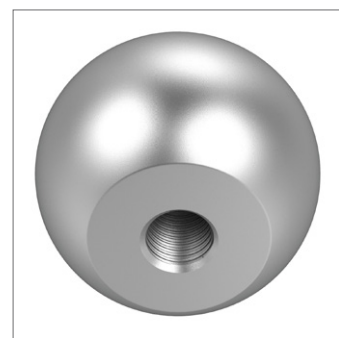
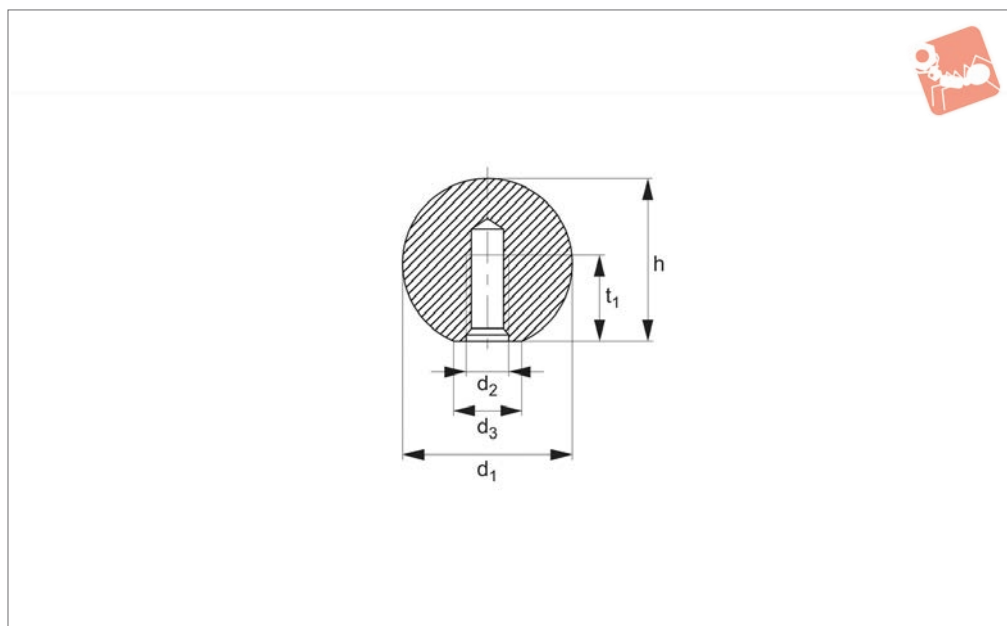

73006

GRIPS

Material

Aluminium, polished polished, bright

Order No.	d ₁	d ₂	d ₃ ≈	h ≈	t ₁ min.	Weight g
73006.W0116	16	M 4	8	15.0	7.0	7
73006.W0120	20	M 5	12	18.0	9.0	12
73006.W0125	25	M 6	15	22.5	11.0	22
73006.W0132	32	M 8	18	29.0	14.5	44
73006.W0140	40	M10	22	37.0	18.0	87
73006.W0150	50	M12	27	46.0	21.0	173

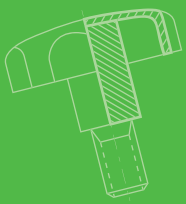

73020

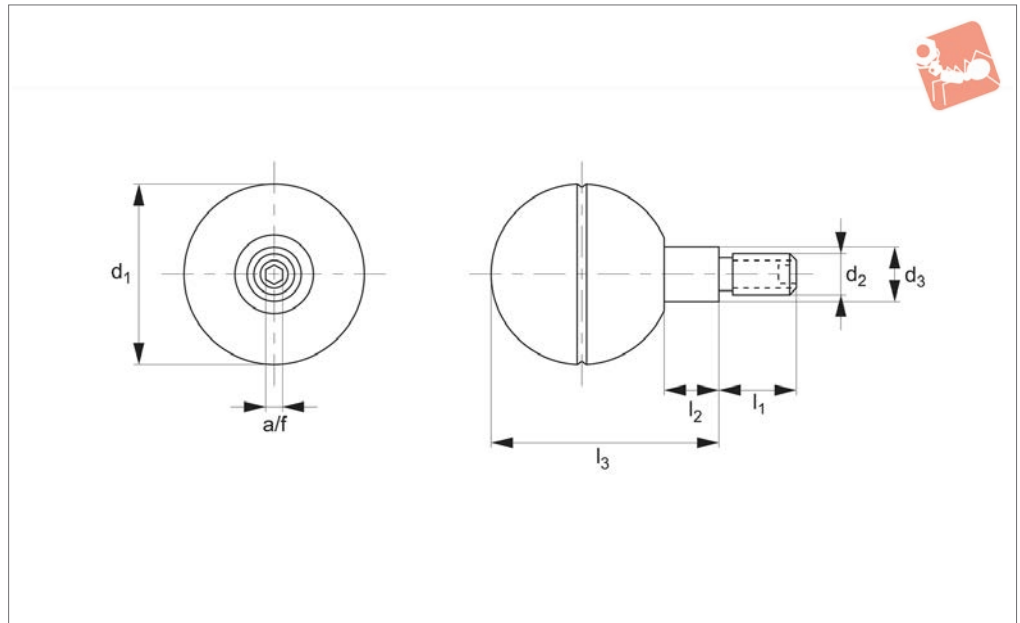

Material

Duroplast, black. Zinc plated steel stud, hexagonal locking blind hole.

Order No.	d ₁	d ₂	l ₁	l ₂	l ₃	d ₃	A/F	Weight g
73020.W0041	41	M 8	15	12	51	13	4	87
73020.W0042	41	M10	17	12	51	13	5	90
73020.W0047	47	M 8	15	12	58	14	4	118
73020.W0048	47	M10	17	12	58	14	5	121
73020.W0061	60	M 8	15	12	71	14	4	206
73020.W0062	60	M10	17	12	71	14	5	212

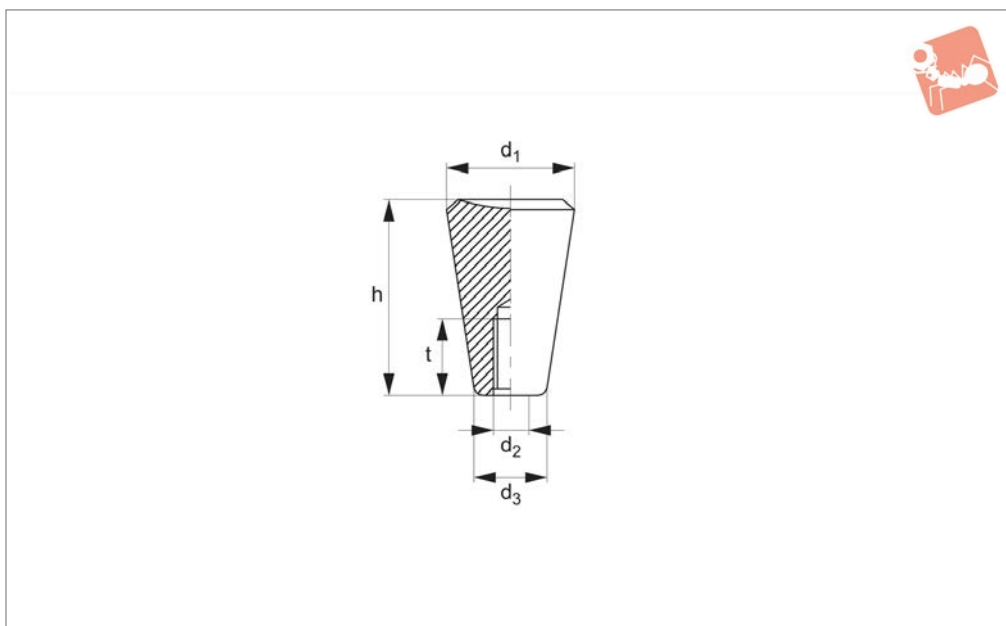
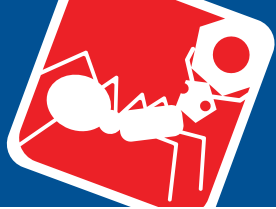

73100

GRIPS

Material

Duroplast PF 31, black.

Technical Notes

Temperature range max. 110°C.

Order No.	d ₁	d ₂	d ₃ ≈	h	t min.	Weight g
73100.W0020	20	M 5	12	30	18	7.8
73100.W0021	20	M 6	12	30	18	7.4
73100.W0025	25	M 6	15	38	18	14.0
73100.W0026	25	M 8	15	38	18	13.0
73100.W0031	30	M 8	18	46	18	26.0
73100.W0032	30	M10	18	46	18	25.0
73100.W0036	35	M10	21	53	21	46.0
73100.W0037	35	M12	21	53	21	43.0



73110

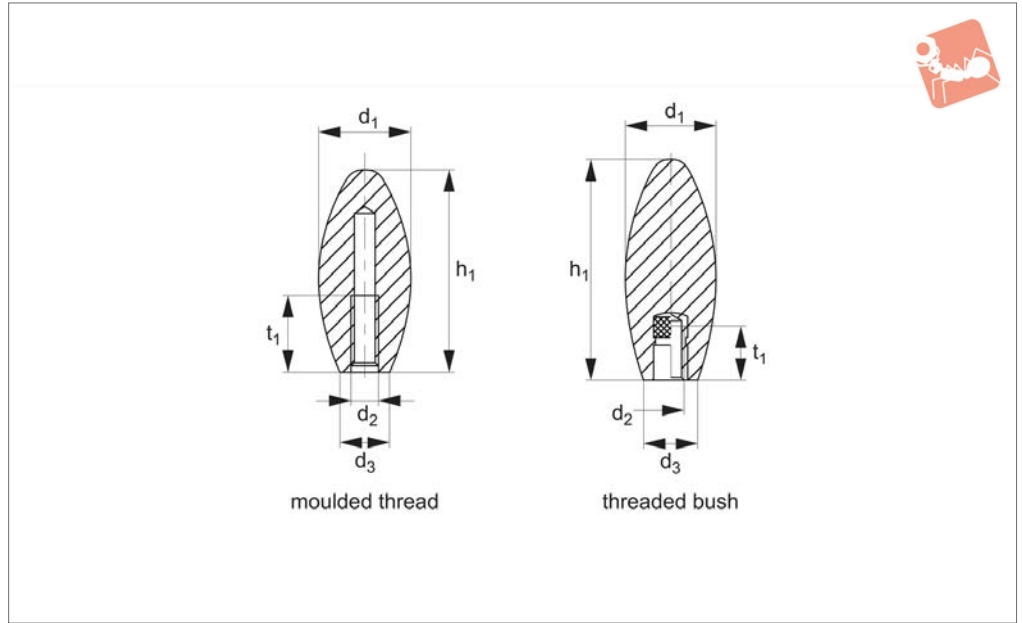

Material

Duroplast, black.

Bush: zinc plated steel.

Order No.	Finish	d ₁	d ₂	d ₃	h ₁	t ₁	Weight g
73110.W0030	Moulded Thread	30	M 8	16	65	16	41
73110.W0031	Moulded Thread	30	M10	16	65	21	40
73110.W0032	Moulded Thread	30	M12	16	65	25	39
73110.W0035	Moulded Thread	35	M12	22	85	25	71
73110.W0036	Moulded Thread	35	M16	22	85	30	69
73110.W0535	Threaded Bush	35	M10	22	85	21	87

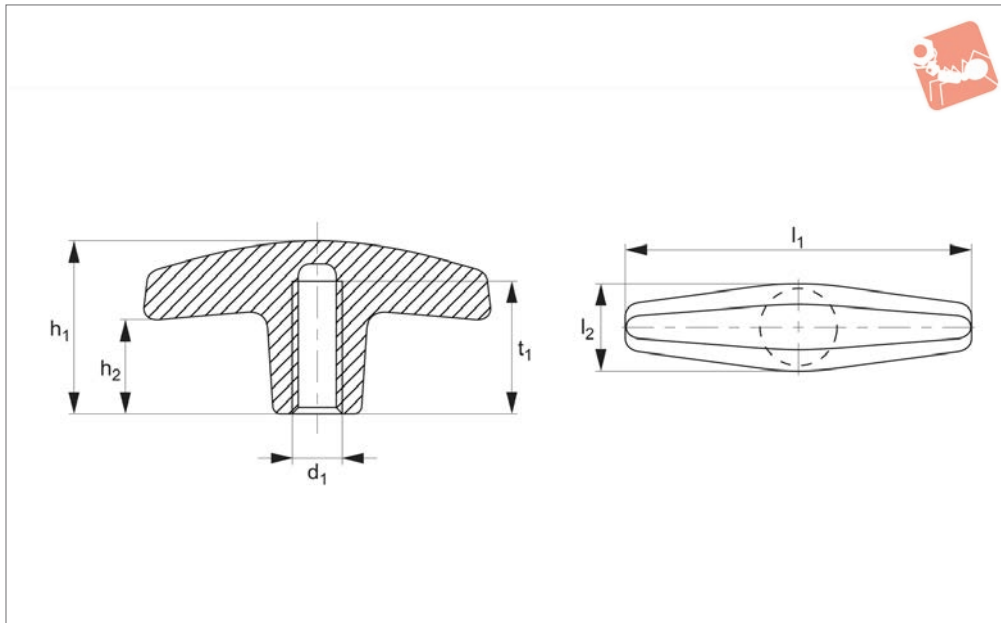
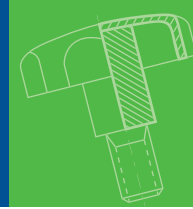

73130

GRIPS

Material

Thermoplast, black, with moulded female thread.

Order No.	d_1	l_1	l_2	h_1	h_2	t_1	Weight g
73130.W0006	M 6	57	15	30	16	13	9
73130.W0008	M 8	57	15	30	16	15	8

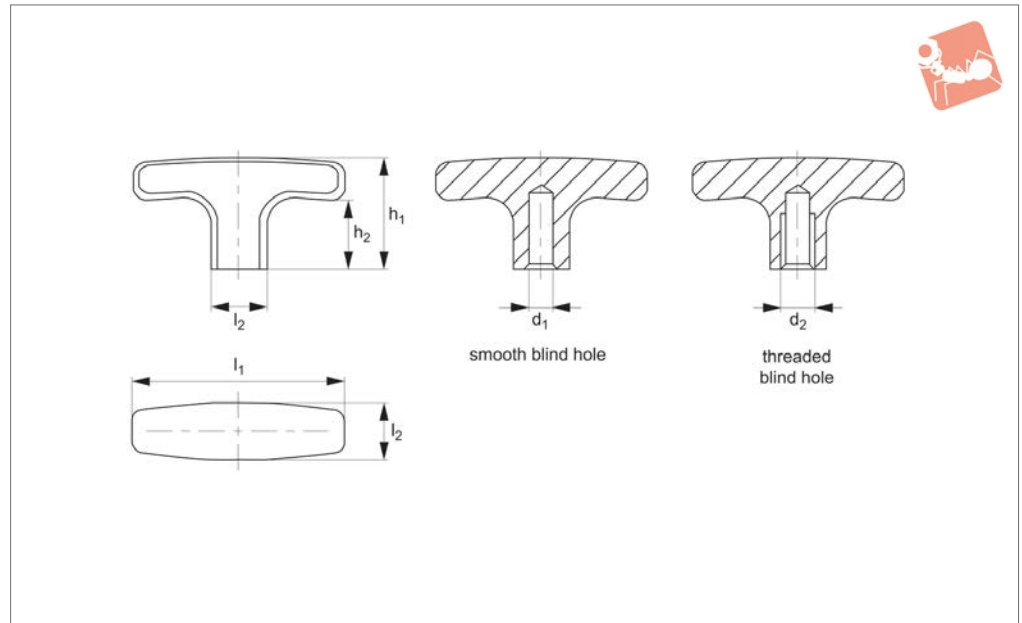

73132

**Material**

Aluminium, plastic coated, similar to RAL
9005 black, matt structure

Order No.	Finish	d_1 tol. H7	d_2	l_1	l_2	h_1	h_2	t	Weight g
73132.W0020	Smooth, Blind	6	-	55	14	33	22	12	31
73132.W0030	Smooth, Blind	8	-	67	16	37	25	16	46
73132.W0035	Smooth, Blind	8	-	80	20	41	26	16	80
73132.W0120	Threaded, Blind	-	M 6	55	14	33	22	12	33
73132.W0125	Threaded, Blind	-	M 8	55	14	33	22	12	40
73132.W0130	Threaded, Blind	-	M 8	67	16	37	25	16	48
73132.W0135	Threaded, Blind	-	M 8	80	20	41	26	16	80
73132.W0140	Threaded, Blind	-	M10	80	20	41	26	16	80

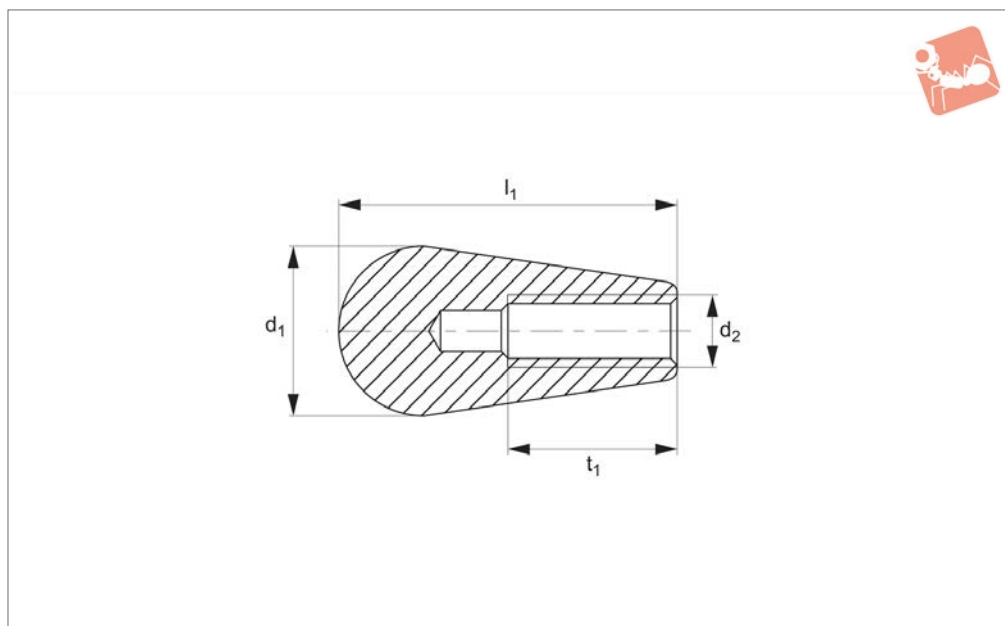

73140

GRIPS

Material

Thermoplastic, matte black, with moulded female thread.

Technical Notes

* $\varnothing 8$ - moulded blind hole - not threaded.

Order No.	d_1	d_2	l_1	t_1	Weight g
73140.W0005	13	M 5	43	15	3.2
73140.W0008	25	M 8	50	25	13.0
73140.W0009	25	M 8	50	25	12.0



73160

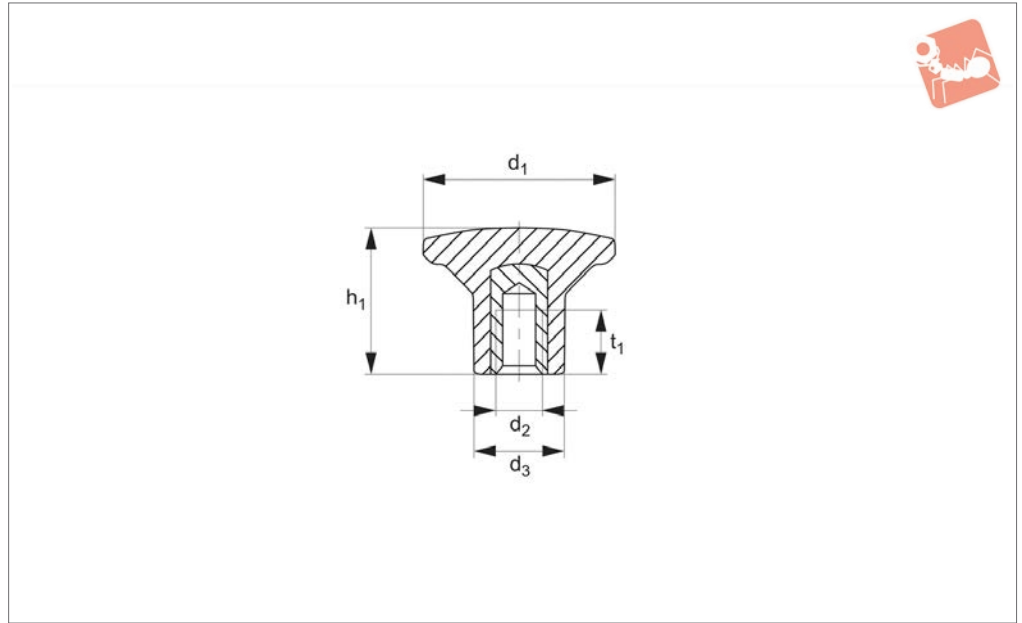

Material

Thermoplastic, matt black. Brass bush with tapped blind hole.

Order No.	d_1	d_2	d_3	h_1	t_1	Weight g
73160.W0021	26	M 4	12	17	8	8
73160.W0022	26	M 5	12	17	8	8
73160.W0023	26	M 6	12	17	8	8
73160.W0031	32	M 6	15	24	13	13
73160.W0032	32	M 8	15	24	13	13

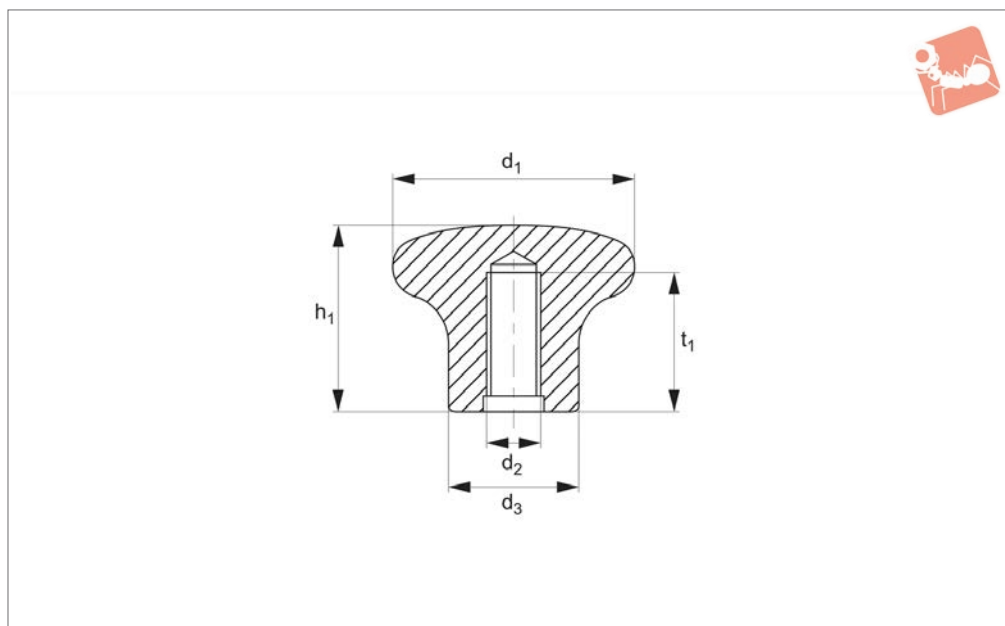
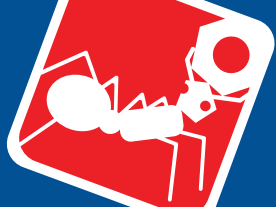

73170

GRIPS

Material

Duroplast, black, moulded thread.

Order No.	d ₁	d ₂	d ₃	h ₁	t ₁	Weight g
73170.W0031	35	M 6	17	35	20	19
73170.W0032	35	M 8	17	35	20	18
73170.W0051	45	M 8	24	34	23	36
73170.W0052	45	M10	24	34	23	35
73170.W0053	45	M12	24	34	23	34

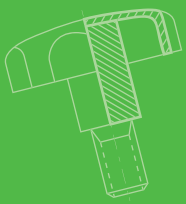

73180

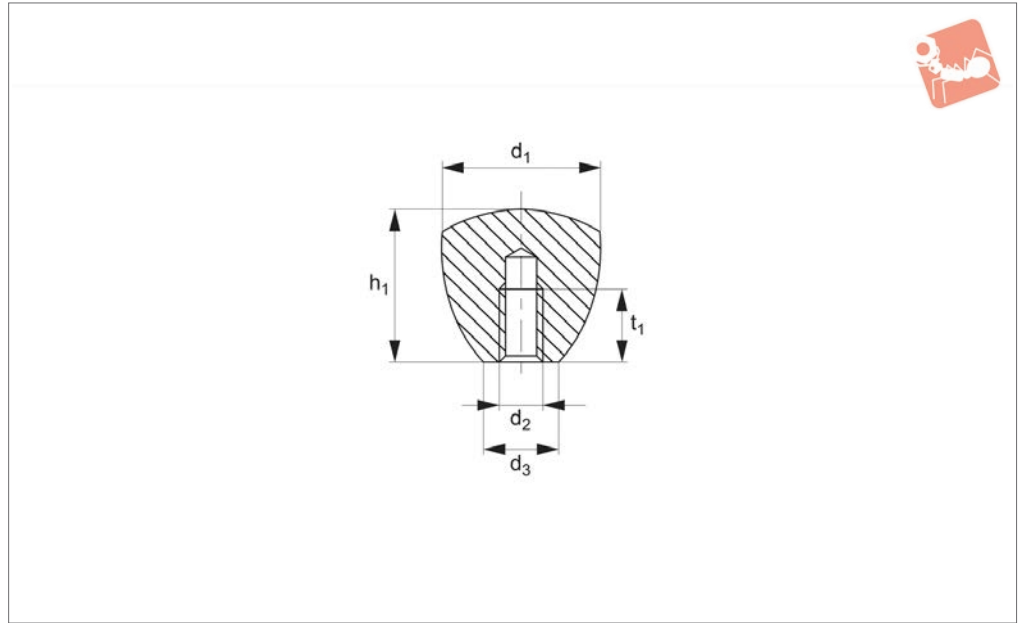

Material

Duroplast, black. Moulded thread.

Order No.	d ₁	d ₂	d ₃	h ₁	t ₁	Weight g
73180.W0031	30	M 6	15	30	22	21
73180.W0032	30	M 8	15	30	22	20
73180.W0033	30	M10	15	30	22	20

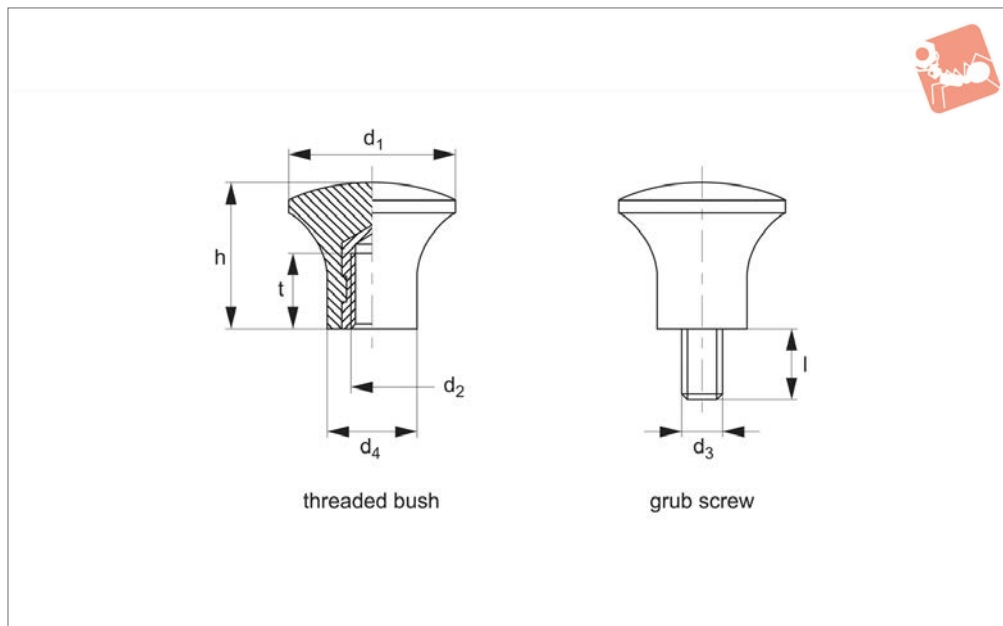
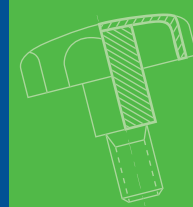
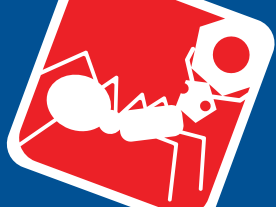

73200

GRIPS

Material

Black, duroplast PF31.
Brass bush or zinc plated steel male

thread.

Technical Notes

Max. temperature 110°C.

Order No.	Type	d ₁	d ₂	d ₃	l	d ₄	h	t	Weight g
73200.W0017	Threaded Bush	17	M 5	-	-	10	14	7	4.8
73200.W0021	Threaded Bush	21	M 6	-	-	12	17	11	8.2
73200.W0025	Threaded Bush	25	M 6	-	-	14	21	11	11.0
73200.W0033	Threaded Bush	33	M 8	-	-	18	29	12	19.0
73200.W0117	Grub Screw	17	-	M 5	9	10	14	-	4.2
73200.W0121	Grub Screw	21	-	M 6	10	12	17	-	7.1
73200.W0125	Grub Screw	25	-	M 6	10	14	21	-	10.0
73200.W0133	Grub Screw	33	-	M 8	14	18	29	-	23.0



Three Lobe Knob
with stainless steel bush

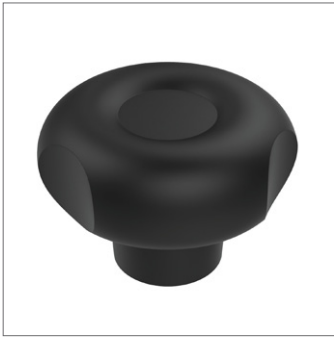

70580

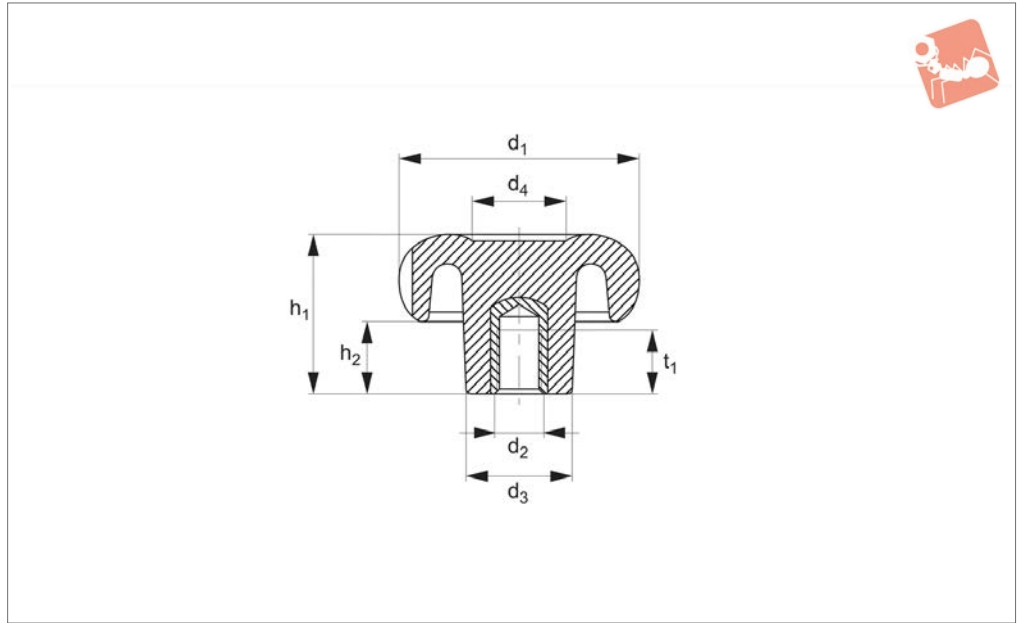

Material

Grip: thermoplastic, black.
Bush: stainless steel.

Order No.	d ₁	d ₂	d ₃	d ₄	h ₁	h ₂	t ₁	Weight g
70580.W0060	30	M 6	14	11	22	11	9	11
70580.W0080	40	M 8	18	15	28	13	13	26
70580.W0100	50	M10	22	20	33	15	16	43



Three Lobe Knob with stainless steel grub screw



Grips

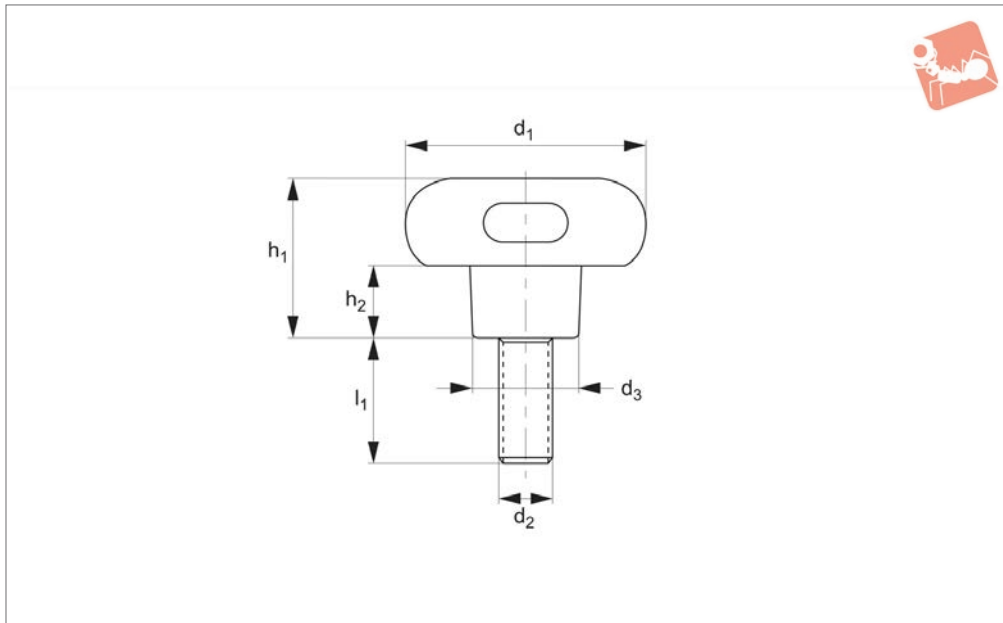

70590

GRIPS

Material

Grip: thermoplastic, black.

Grub screw: stainless steel.

Order No.	d ₁	d ₂	l ₁	d ₃	h ₁	h ₂	Weight g
70590.W0061	30	M 6	20	14	22	11	18
70590.W0062	30	M 6	30	14	22	11	20
70590.W0081	40	M 8	20	18	28	13	20
70590.W0082	40	M 8	30	18	28	13	23
70590.W0101	50	M10	25	22	33	15	60
70590.W0102	50	M10	30	22	33	15	64



70620

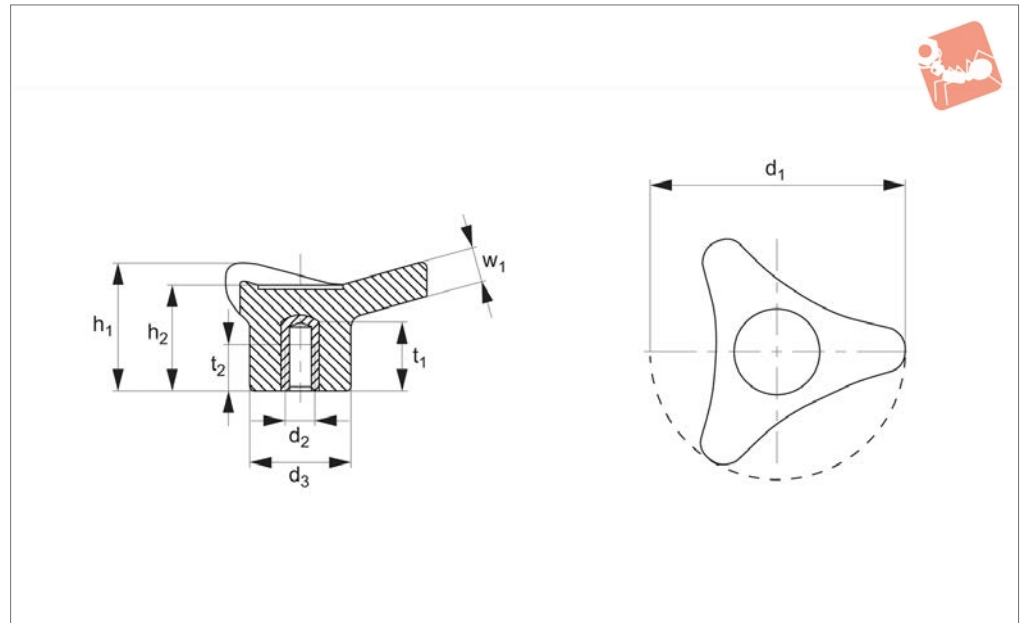

Material

Brass bush. Duroplast, black.

Order No.	d_1	d_2	d_3	h_1	h_2	t_1	t_2	w_1	Weight g
70620.W0345	34	M 5	17	22	20	12	9	7.0	11
70620.W0346	34	M 6	17	22	20	12	9	7.0	11
70620.W0348	34	M 8	17	22	20	12	9	7.0	12
70620.W0456	45	M 6	25	30	27	18	13	8.5	26
70620.W0458	45	M 8	25	30	27	18	15	8.5	27
70620.W0459	45	M10	25	30	27	18	16	8.5	28
70620.W0658	65	M 8	30	39	36	25	15	10.0	51
70620.W0659	65	M10	30	39	36	25	16	10.0	51
70620.W0660	65	M12	30	39	36	25	18	10.0	56
70620.W0858	85	M 8	35	48	43	30	15	12.0	89
70620.W0859	85	M10	35	48	43	30	16	12.0	89
70620.W0860	85	M12	35	48	43	30	18	12.0	94
70620.W0861	85	M16	35	48	43	30	20	12.0	100



Three Lobed Knobs with grub screw

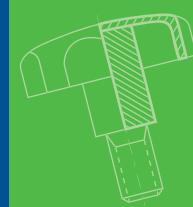

Grips

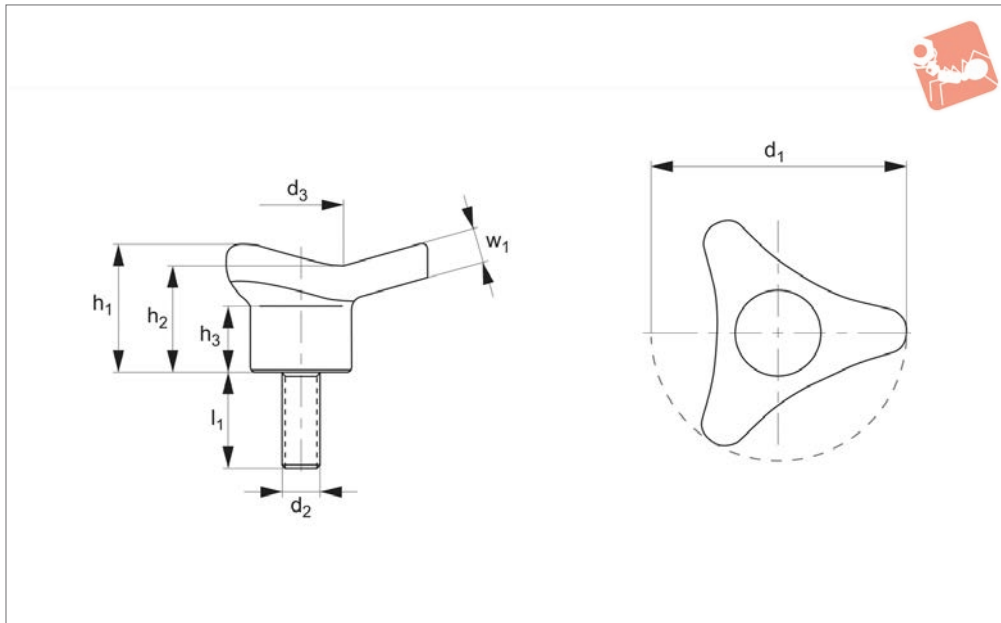

70630

GRIPS

Material

Zinc plated steel stud. Duroplast, black.

Order No.	d ₁	d ₂	l ₁	d ₃	h ₁	h ₂	h ₃	w ₁	Weight g
70630.W0341	34	M 6	20	17	22	20	12	7.0	15.0
70630.W0342	34	M 6	25	17	22	20	12	7.0	16.0
70630.W0343	34	M 6	30	17	32	20	12	7.0	17.0
70630.W0344	34	M 8	20	17	22	20	12	7.0	19.0
70630.W0345	34	M 8	25	17	22	20	12	7.0	20.0
70630.W0451	41	M 8	20	25	30	27	18	8.5	35.0
70630.W0452	41	M 8	30	25	30	27	18	8.5	37.0
70630.W0453	41	M 8	40	25	30	27	18	8.5	41.0
70630.W0454	41	M10	30	25	30	27	18	8.5	46.0
70630.W0651	65	M 8	40	30	39	36	25	10.0	65.0
70630.W0652	65	M10	30	30	39	36	25	10.0	71.0
70630.W0851	85	M12	20	35	48	43	30	12.0	124.0
70630.W0852	85	M12	35	35	48	43	30	12.0	130.0



70640

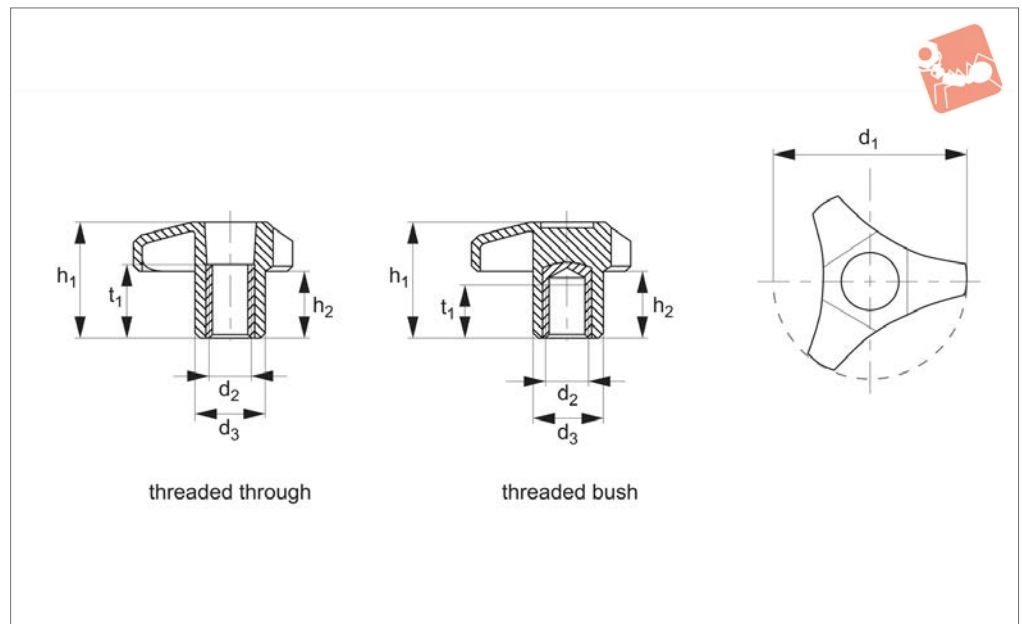

Material

Brass bush. Thermoplastic, matt black.

Order No.	Type	d ₁	d ₂	d ₃	h ₁	h ₂	t ₁	Weight g
70640.W0045	Threaded Through	45	M 6	18	27	16	15	12.4
70640.W0046	Threaded Through	45	M 8	18	27	16	15	13.2
70640.W0047	Threaded Through	45	M10	18	27	16	15	13.2
70640.W0055	Threaded Through	55	M 8	20	33	19	15	18.2
70640.W0056	Threaded Through	55	M10	20	33	19	15	19.2
70640.W0057	Threaded Through	55	M12	20	33	19	15	19.8
70640.W0146	Threaded Bush	45	M 6	18	27	16	14	13.8
70640.W0148	Threaded Bush	45	M 8	18	27	16	14	15.6
70640.W0150	Threaded Bush	45	M10	18	27	16	14	17.2
70640.W0155	Threaded Bush	55	M 8	20	33	19	14	22.8
70640.W0156	Threaded Bush	55	M10	20	33	19	14	23.4
70640.W0157	Threaded Bush	55	M12	20	33	19	14	25.6



Three Lobed Knobs with grub screw



Grips

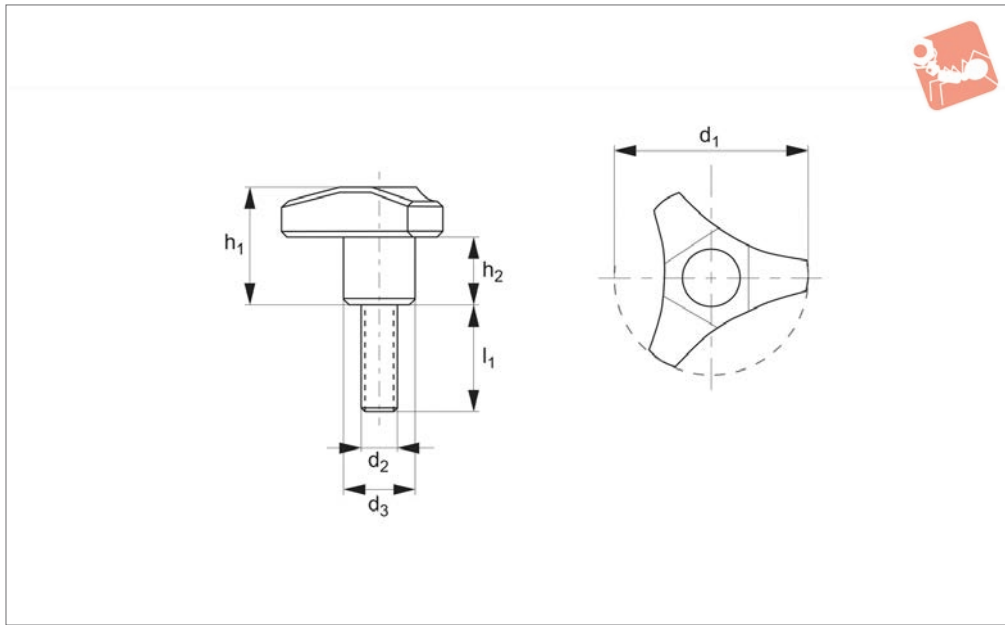

70660

GRIPS

Material

Zinc plated steel stud. Thermoplastic, matt black.

Order No.	d ₁	d ₂	l ₁	d ₃	h ₁	h ₂	Weight g
70660.W0451	45	M 6	20	18	27	16	16.4
70660.W0452	45	M 6	25	18	27	16	17.0
70660.W0453	45	M 6	40	18	27	16	20.0
70660.W0454	45	M 8	20	18	27	16	20.2
70660.W0455	45	M 8	25	18	27	16	23.6
70660.W0456	45	M 8	40	18	27	16	27.0
70660.W0457	45	M10	20	18	27	16	30.0
70660.W0458	45	M10	30	18	27	16	35.0
70660.W0551	55	M 6	20	20	33	19	22.8
70660.W0552	55	M 6	25	20	33	19	23.6
70660.W0553	55	M 6	40	20	33	19	26.8
70660.W0554	55	M 8	20	20	33	19	27.2
70660.W0556	55	M 8	40	20	33	19	33.4
70660.W0560	55	M 8	30	20	33	19	30.1
70660.W0557	55	M10	20	20	33	19	36.4
70660.W0558	55	M10	30	20	33	19	42.0



70680

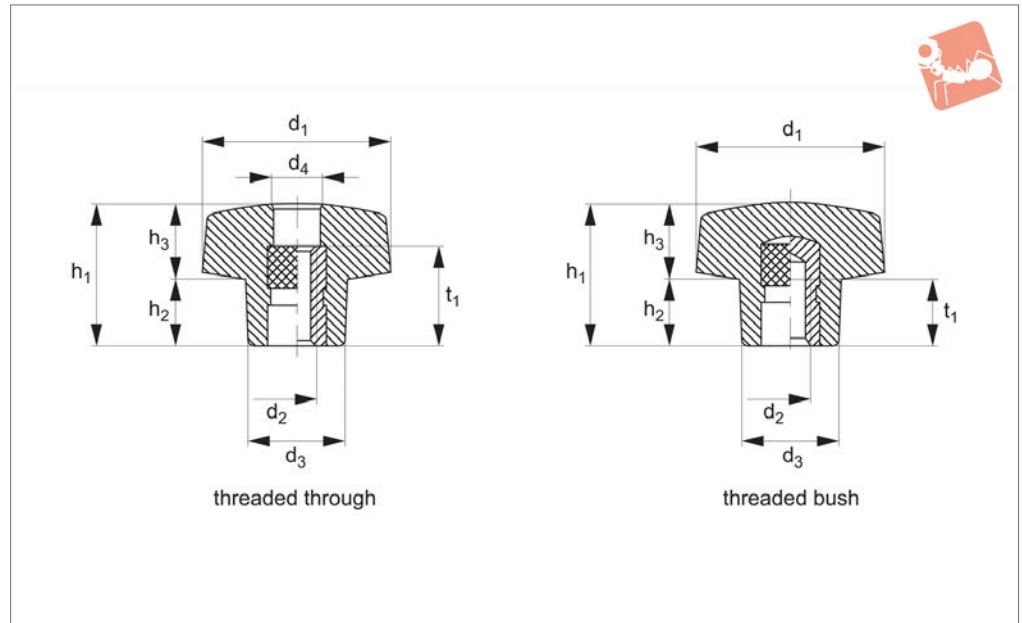

Material

Brass bush. Duroplast, black.

Order No.	Type	d ₁	d ₂	d ₃	d ₄	h ₁	h ₂	h ₃	t ₁	Weight g
70680.W0021	Threaded Through	20	M 4	13	7.5	15	7	8.0	11	6
70680.W0022	Threaded Through	20	M 5	13	7.5	15	7	8.0	11	7
70680.W0023	Threaded Through	20	M 6	13	7.5	15	7	8.0	11	10
70680.W0031	Threaded Through	30	M 5	17	9.0	24	11	12.5	15	15
70680.W0032	Threaded Through	30	M 6	17	9.0	24	11	12.5	15	16
70680.W0033	Threaded Through	30	M 8	17	9.0	24	11	12.5	15	17
70680.W0204	Threaded Bush	20	M 4	13	-	15	7	8.0	9	5
70680.W0205	Threaded Bush	20	M 5	13	-	15	7	8.0	9	5
70680.W0206	Threaded Bush	20	M 6	13	-	15	7	8.0	9	5
70680.W0305	Threaded Bush	30	M 5	17	-	24	11	13.0	9	14
70680.W0306	Threaded Bush	30	M 6	17	-	24	11	13.0	9	15
70680.W0308	Threaded Bush	30	M 8	17	-	24	11	13.0	15	17
70680.W0406	Threaded Bush	40	M 6	21	-	28	12	16.0	13	35
70680.W0408	Threaded Bush	40	M 8	21	-	28	12	16.0	15	34
70680.W0410	Threaded Bush	40	M10	21	-	28	12	16.0	16	36
70680.W0508	Threaded Bush	50	M 8	25	-	33	13	20.0	15	54
70680.W0510	Threaded Bush	50	M10	25	-	33	13	20.0	16	56
70680.W0512	Threaded Bush	50	M12	25	-	33	13	20.0	18	58

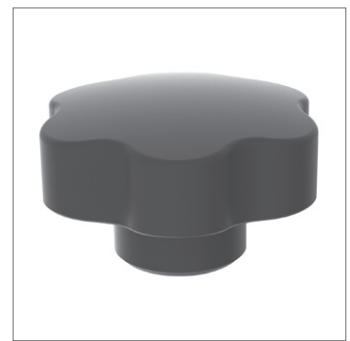
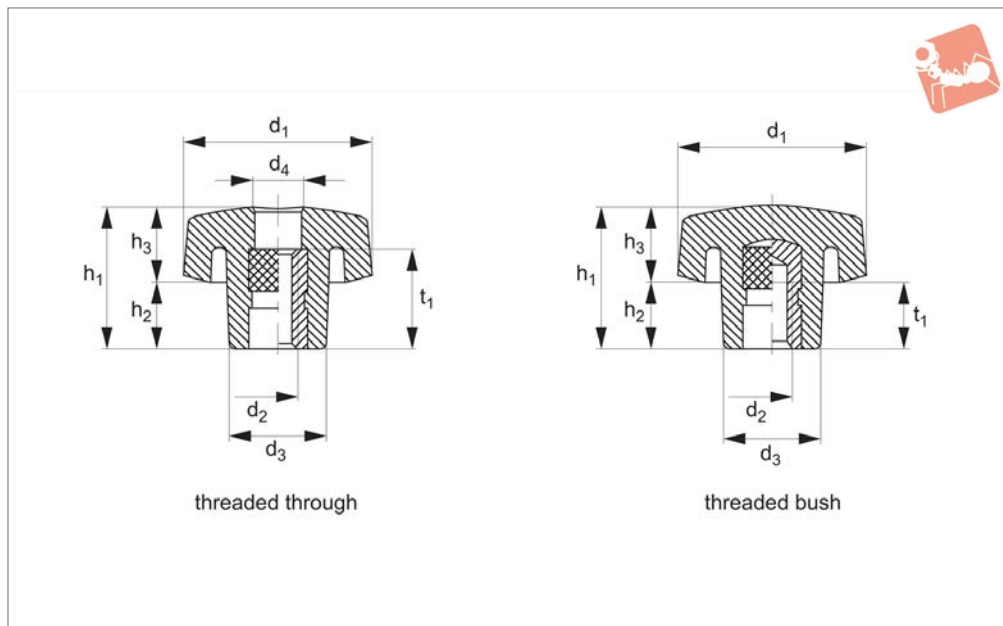
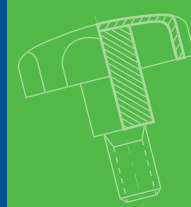

70700

GRIPS

Material

Brass bush. Duroplast, black.

Order No.	Type	d ₁	d ₂	d ₃	d ₄	h ₁	h ₂	h ₃	t ₁	Weight g
70700.W0041	Threaded Through	40	M 6	21	11	28	13	15	18	28
70700.W0042	Threaded Through	40	M 8	21	11	28	13	15	18	29
70700.W0043	Threaded Through	40	M10	21	11	28	13	15	18	31
70700.W0051	Threaded Through	50	M 8	25	13	33	15	18	18	43
70700.W0052	Threaded Through	50	M10	25	13	33	15	18	18	45
70700.W0053	Threaded Through	50	M12	25	13	33	15	18	18	47
70700.W0061	Threaded Through	60	M10	28	11	35	15	20	25	70
70700.W0062	Threaded Through	60	M12	28	13	35	15	20	25	70
70700.W0063	Threaded Through	60	M14	28	15	35	15	20	25	70
70700.W0064	Threaded Through	60	M16	28	17	35	15	20	25	68
70700.W0071	Threaded Through	70	M10	32	11	42	21	21	25	92
70700.W0072	Threaded Through	70	M12	32	13	42	21	21	25	96
70700.W0073	Threaded Through	32	M14	70	15	42	21	21	25	94
70700.W0074	Threaded Through	70	M16	32	17	42	21	21	25	93
70700.W0406	Threaded Bush	40	M 6	21	-	28	13	15	13	26
70700.W0408	Threaded Bush	40	M 8	21	-	28	13	15	15	30
70700.W0410	Threaded Bush	40	M10	21	-	28	13	15	16	31
70700.W0508	Threaded Bush	50	M 8	25	-	33	15	18	15	48
70700.W0510	Threaded Bush	50	M10	25	-	33	15	18	16	49
70700.W0512	Threaded Bush	50	M12	25	-	33	15	18	18	50
70700.W0608	Threaded Bush	60	M 8	28	-	35	15	20	15	67
70700.W0610	Threaded Bush	60	M10	28	-	35	15	20	16	68
70700.W0612	Threaded Bush	60	M12	28	-	35	15	20	18	70
70700.W0614	Threaded Bush	60	M14	28	-	35	15	20	20	75
70700.W0620	Threaded Bush	60	M16	28	-	35	15	20	20	77
70700.W0710	Threaded Bush	70	M10	32	-	42	21	21	16	92
70700.W0712	Threaded Bush	70	M12	32	-	42	21	21	18	95
70700.W0714	Threaded Bush	70	M14	32	-	42	21	21	20	100
70700.W0716	Threaded Bush	70	M16	32	-	42	21	21	20	102
70700.W0912	Threaded Bush	90	M12	42	-	55	26	29	18	202
70700.W0914	Threaded Bush	90	M14	42	-	55	26	29	20	201
70700.W0916	Threaded Bush	90	M16	42	-	55	26	29	20	201
70700.W0918	Threaded Bush	90	M18	42	-	55	26	29	20	217



70720

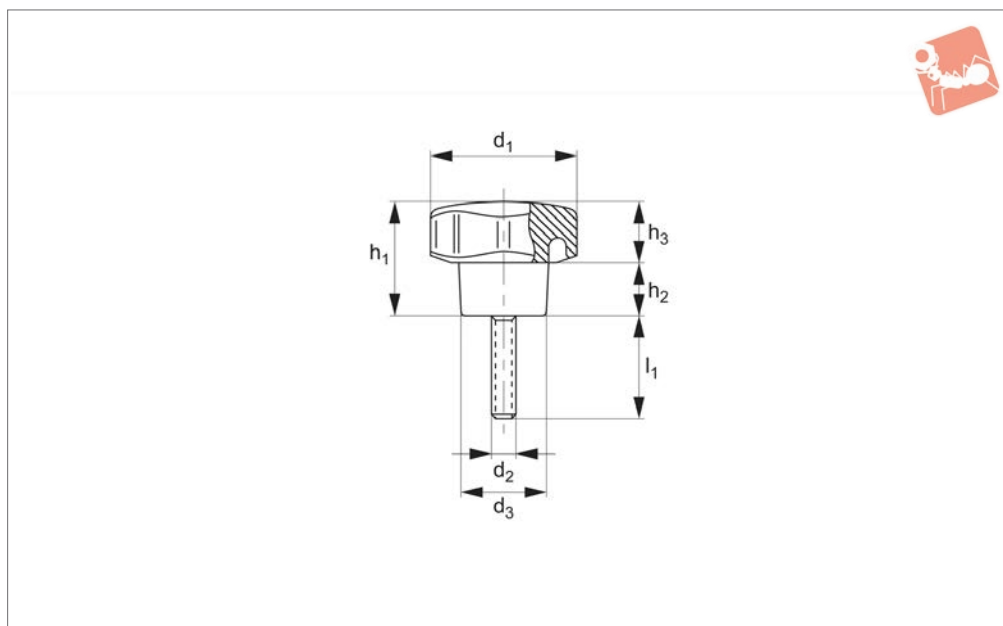

Material

Zinc plated steel stud. Duroplast, black.

Order No.	d ₁	d ₂	l ₁	d ₃	h ₁	h ₂	h ₃	Weight g
70720.W0040	40	M 6	25	21	28	13	15	34
70720.W0041	40	M 6	40	21	28	13	15	37
70720.W0042	40	M 8	20	21	28	13	15	38
70720.W0043	40	M 8	25	21	28	13	15	39
70720.W0044	40	M 8	30	21	28	13	15	40
70720.W0045	40	M 8	40	21	28	13	15	44
70720.W0046	40	M 8	50	21	28	13	15	46
70720.W0047	40	M 8	70	21	28	13	15	55
70720.W0048	40	M10	50	21	28	13	15	60
70720.W0049	40	M10	70	21	28	13	15	70
70720.W0050	50	M 8	25	25	33	15	18	55
70720.W0051	50	M 8	40	25	33	15	18	60
70720.W0052	50	M 8	60	25	33	15	18	67
70720.W0053	50	M10	25	25	33	15	18	63
70720.W0054	50	M10	40	25	33	15	18	70
70720.W0055	50	M10	50	25	33	15	18	76
70720.W0056	50	M10	15	25	33	15	18	84
70720.W0057	50	M12	40	25	33	15	18	93
70720.W0058	50	M12	60	25	33	15	18	108
70720.W0060	60	M 8	20	28	35	15	20	75
70720.W0061	60	M 8	40	28	35	15	20	80
70720.W0062	60	M 8	60	28	35	15	20	87
70720.W0063	60	M10	20	28	35	15	20	82
70720.W0064	60	M10	40	28	35	15	20	96
70720.W0065	60	M10	60	28	35	15	20	107
70720.W0066	60	M12	30	28	35	15	20	107
70720.W0067	60	M12	50	28	35	15	20	122
70720.W0068	60	M12	60	28	35	15	20	127
70720.W0069	60	M12	80	28	35	15	20	133
70720.W0070	70	M10	30	32	42	21	21	115
70720.W0071	70	M10	40	32	42	21	21	116
70720.W0072	70	M12	30	32	42	21	21	133
70720.W0073	70	M12	40	32	42	21	21	138
70720.W0074	70	M12	50	32	42	21	21	145

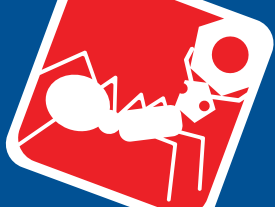

Six Lobed Knobs with grub screw



Grips

Order No.	d ₁	d ₂	l ₁	d ₃	h ₁	h ₂	h ₃	Weight g
70720.W0075	70	M12	70	32	42	21	21	156
70720.W0076	70	M14	40	32	42	21	21	170
70720.W0077	70	M14	50	32	42	21	21	181
70720.W0090	90	M12	60	42	55	26	29	255
70720.W0091	90	M12	70	42	55	26	29	260
70720.W0092	90	M14	60	42	55	26	29	283
70720.W0093	90	M14	70	42	55	26	29	288
70720.W0094	90	M16	60	42	55	26	29	322
70720.W0095	90	M16	70	42	55	26	29	328

GRIPS



70740

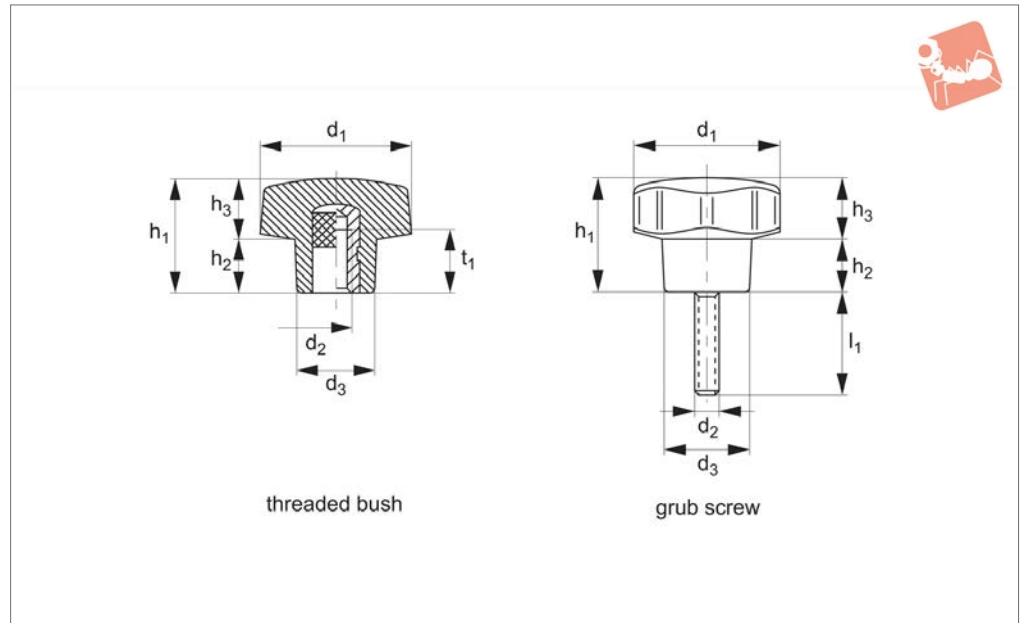

Material

Stainless steel bush or thread AISI 303 (1.4305). Duroplast, black.

Order No.	Type	d ₁	d ₂	l ₁	d ₃	h ₁	h ₂	h ₃	t ₁	Weight g
70740.W0030	Threaded Bush	30	M 6	-	17	24	11	13	9	15
70740.W0040	Threaded Bush	40	M 8	-	21	28	12	16	15	33
70740.W0050	Threaded Bush	50	M10	-	25	33	13	20	16	55
70740.W0060	Threaded Bush	60	M12	-	28	37	15	22	18	85
70740.W0301	Grub Screw	30	M 6	10	17	24	11	13	-	18
70740.W0302	Grub Screw	30	M 6	20	17	24	11	13	-	21
70740.W0303	Grub Screw	30	M 6	35	17	24	11	13	-	22
70740.W0401	Grub Screw	40	M 8	20	21	28	12	16	-	42
70740.W0402	Grub Screw	40	M 8	25	21	28	12	16	-	44
70740.W0403	Grub Screw	40	M 8	30	21	28	12	16	-	46
70740.W0404	Grub Screw	40	M 8	45	21	28	12	16	-	51
70740.W0501	Grub Screw	50	M10	20	25	33	13	20	-	73
70740.W0502	Grub Screw	50	M10	30	25	33	13	20	-	78
70740.W0503	Grub Screw	50	M10	50	25	33	13	20	-	87
70740.W0601	Grub Screw	60	M12	30	28	37	15	22	-	118
70740.W0602	Grub Screw	60	M12	40	28	37	15	22	-	125
70740.W0603	Grub Screw	60	M12	50	28	37	15	22	-	132
70740.W0701	Grub Screw	70	M12	70	32	42	18	24	-	184

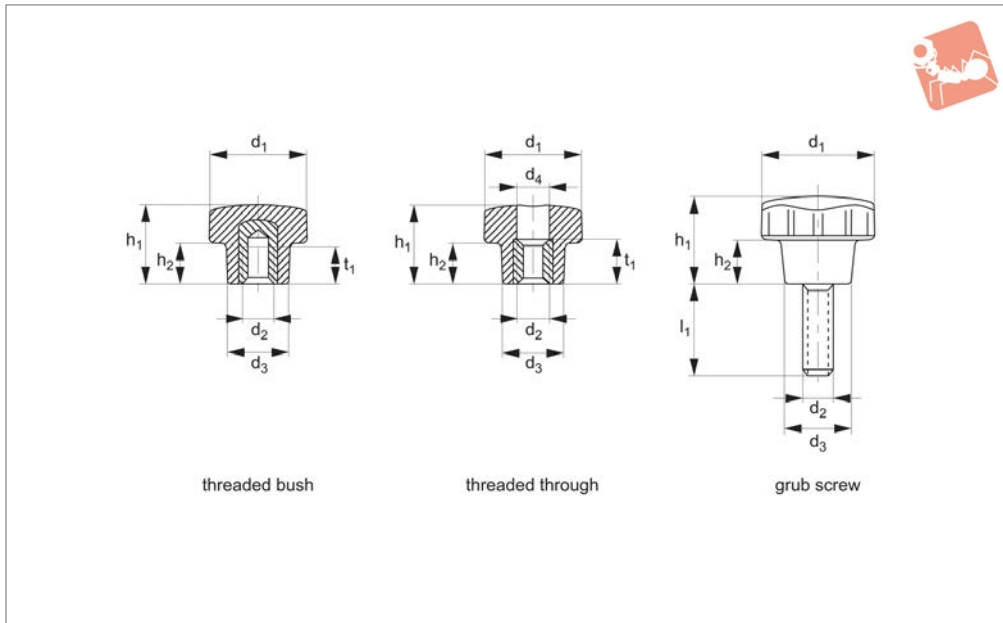
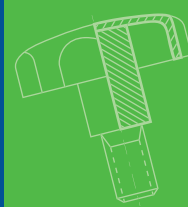

70760

GRIPS

Material

Brass bush. Thermoplastic, black.

Order No.	Type	d ₁	d ₂	l ₁	d ₃	d ₄	h ₁	h ₂	t ₁	Weight g
70760.W0004	Threaded Bush	21	M 4	-	13	-	15	8	8	8
70760.W0005	Threaded Bush	21	M 5	-	13	-	15	8	8	8
70760.W0006	Threaded Bush	21	M 6	-	13	-	15	8	8	8
70760.W0104	Threaded Through	21	M 4	-	13	7	15	8	11	7
70760.W0105	Threaded Through	21	M 5	-	13	7	15	8	11	7
70760.W0106	Threaded Through	21	M 6	-	13	7	15	8	11	7
70760.W0410	Grub Screw	21	M 4	10	13	-	16	8	-	5
70760.W0425	Grub Screw	21	M 4	25	13	-	16	8	-	5
70760.W0510	Grub Screw	21	M 5	10	13	-	16	8	-	6
70760.W0515	Grub Screw	21	M 5	15	13	-	16	8	-	6

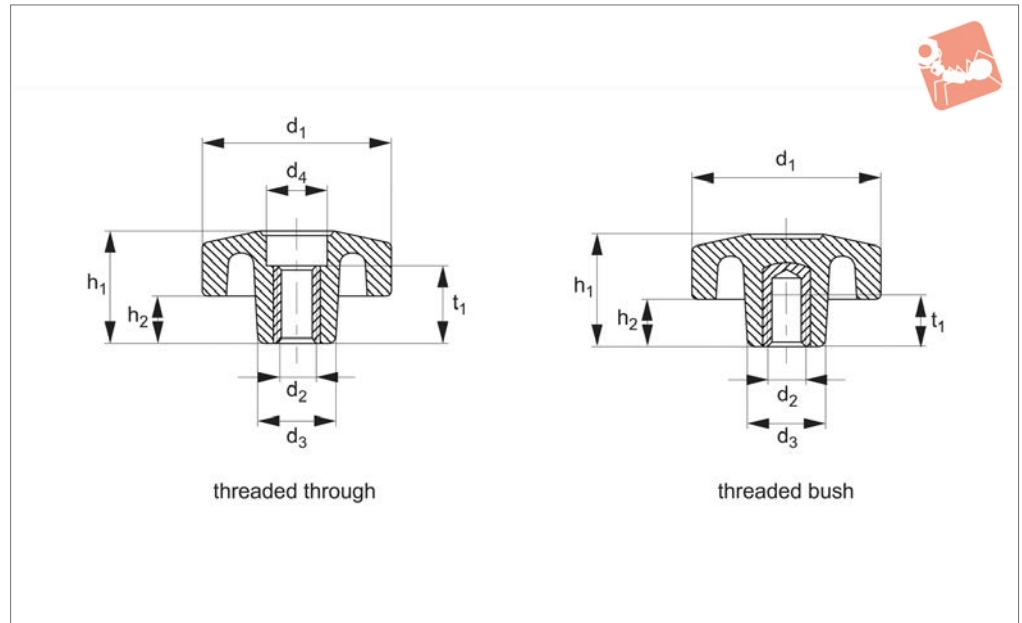

70800

**Material**

Brass bush. Thermoplastic, matte black.

Order No.	Type	d ₁	d ₂	d ₃	h ₁	d ₄	t ₁	h ₂	Weight g
70800.W0021	Threaded Through	25	M 4	13	17	7	11	8	7
70800.W0022	Threaded Through	25	M 5	13	17	7	11	8	8
70800.W0023	Threaded Through	25	M 6	13	17	7	11	8	9
70800.W0031	Threaded Through	35	M 6	18	20	11	15	8	18
70800.W0032	Threaded Through	35	M 8	18	20	11	15	8	18
70800.W0033	Threaded Through	35	M10	18	20	11	15	8	19
70800.W0042	Threaded Through	45	M 6	22	26	11	18	12	27
70800.W0043	Threaded Through	45	M 8	22	26	11	18	12	28
70800.W0044	Threaded Through	45	M10	22	26	11	18	12	30
70800.W0051	Threaded Through	55	M 8	25	29	13	18	15	40
70800.W0052	Threaded Through	55	M10	25	29	13	18	15	41
70800.W0053	Threaded Through	55	M12	25	29	13	18	15	42
70800.W0254	Threaded Bush	25	M 4	13	17	-	9	8	7
70800.W0255	Threaded Bush	25	M 5	13	17	-	9	8	7
70800.W0256	Threaded Bush	25	M 6	13	17	-	9	8	7
70800.W0356	Threaded Bush	35	M 6	18	20	-	13	8	16
70800.W0358	Threaded Bush	35	M 8	18	20	-	13	8	17
70800.W0359	Threaded Bush	35	M10	18	20	-	13	8	18
70800.W0455	Threaded Bush	45	M 5	22	26	-	13	12	27
70800.W0456	Threaded Bush	45	M 6	22	26	-	13	12	27
70800.W0458	Threaded Bush	45	M 8	22	26	-	13	12	28
70800.W0459	Threaded Bush	45	M10	22	26	-	13	12	29
70800.W0558	Threaded Bush	55	M 8	25	29	-	15	15	43
70800.W0559	Threaded Bush	55	M10	25	29	-	16	15	44
70800.W0562	Threaded Bush	55	M12	25	29	-	18	15	45



Eight Lobed Knobs with grub screw

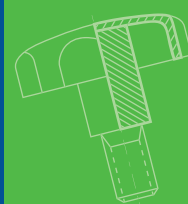

Grips

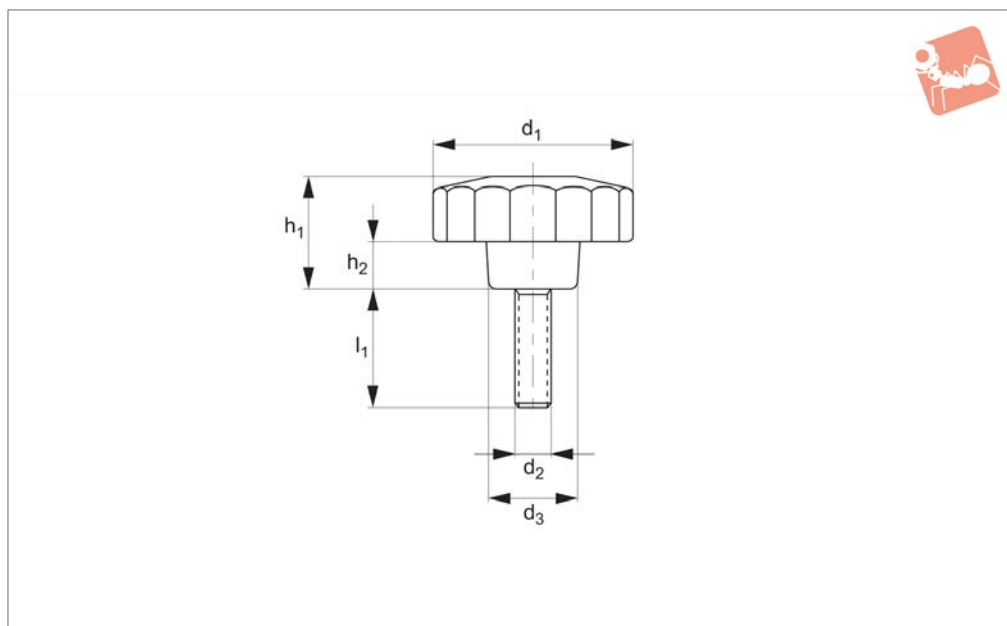

70820

GRIPS

Material

Zinc plated steel stud. Thermoplastic, black, matte.

Order No.	d ₁	d ₂	l ₁	d ₃	h ₁	h ₂	Weight g
70820.W0021	25	M 4	15	13	17	8	7
70820.W0022	25	M 5	15	13	17	8	8
70820.W0023	25	M 5	25	13	17	8	9
70820.W0024	25	M 6	15	13	17	8	10
70820.W0025	25	M 6	20	13	17	8	11
70820.W0026	25	M 6	25	13	17	8	12
70820.W0031	35	M 6	15	18	20	8	19
70820.W0032	35	M 6	25	18	20	8	20
70820.W0033	35	M 6	35	18	20	8	22
70820.W0034	35	M 8	20	18	20	8	26
70820.W0035	35	M 8	25	18	20	8	26
70820.W0036	35	M 8	40	18	20	8	29
70820.W0037	35	M10	30	18	20	8	35
70820.W0041	45	M 8	20	22	26	12	37
70820.W0042	45	M 8	25	22	26	12	38
70820.W0043	45	M 8	30	22	26	12	39
70820.W0044	45	M 8	40	22	26	12	41
70820.W0045	45	M10	20	22	26	12	44
70820.W0046	45	M10	30	22	26	12	51
70820.W0047	45	M10	40	22	26	12	54
70820.W0051	55	M 8	20	25	29	15	50
70820.W0052	55	M 8	30	25	29	15	53
70820.W0053	55	M 8	40	25	29	15	56
70820.W0054	55	M10	20	25	29	15	57
70820.W0055	55	M10	30	25	29	15	63
70820.W0056	55	M10	40	25	29	15	68
70820.W0057	55	M12	30	25	29	15	83
70820.W0058	55	M12	40	25	29	15	90



78000

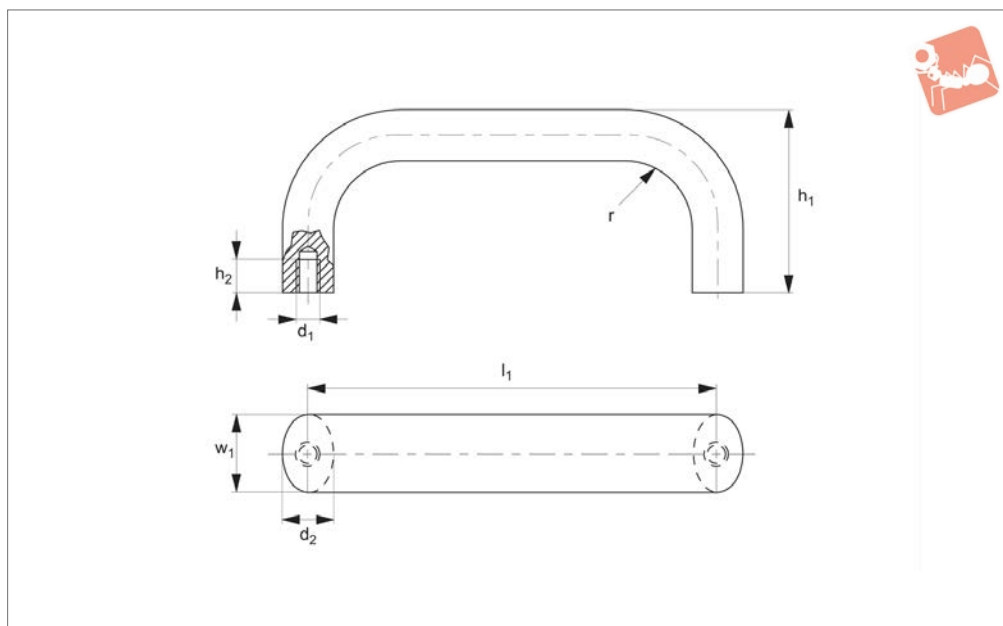

Material

Aluminium: plastic coated, black RAL9005
Natural silver anodised, bright.

Technical Notes

Ergonomic design offering high stability and smooth surfaces.

Order No.	Colour	l_1	w_1	h_1	d_1	d_2	h_2	R	Weight g
78000.W0010	Black	100	20	47	M 6	13	10	13	92
78000.W0011	Black	112	20	49	M 6	13	10	13	97
78000.W0012	Black	128	20	51	M 6	13	10	13	110
78000.W0013	Black	117	20	49	M 6	13	10	13	100
78000.W0014	Black	120	20	49	M 6	13	10	13	97
78000.W0016	Black	160	20	51	M 6	13	10	13	126
78000.W0111	Black	112	26	53	M 8	17	12	17	165
78000.W0112	Black	128	26	55	M 8	17	12	17	181
78000.W0113	Black	117	26	55	M 8	17	12	17	166
78000.W0114	Black	120	26	55	M 8	17	12	17	200
78000.W0115	Black	125	26	55	M 8	17	12	17	180
78000.W0116	Black	160	26	57	M 8	17	12	17	219
78000.W0117	Black	179	26	57	M 8	17	12	17	234
78000.W0119	Black	192	26	57	M 8	17	12	17	250
78000.W0130	Black	300	26	57	M 8	17	12	17	347
78000.W0140	Black	400	26	57	M 8	17	12	17	445
78000.W0150	Black	500	26	57	M 8	17	12	17	538
78000.W0210	Natural	100	20	47	M 6	13	10	13	92
78000.W0211	Natural	112	20	49	M 6	13	10	13	97
78000.W0212	Natural	128	20	51	M 6	13	10	13	110
78000.W0213	Natural	117	20	49	M 6	13	10	13	100
78000.W0214	Natural	120	20	49	M 6	13	10	13	97
78000.W0216	Natural	160	20	51	M 6	13	10	13	126
78000.W0311	Natural	112	26	53	M 8	17	12	17	165
78000.W0312	Natural	128	26	55	M 8	17	12	17	181
78000.W0313	Natural	117	26	55	M 8	17	12	17	166
78000.W0314	Natural	120	26	55	M 8	17	12	17	200
78000.W0315	Natural	125	26	55	M 8	17	12	17	180
78000.W0316	Natural	160	26	57	M 8	17	12	17	219
78000.W0317	Natural	179	26	57	M 8	17	12	17	234
78000.W0319	Natural	192	26	57	M 8	17	12	17	250
78000.W0330	Natural	300	26	57	M 8	17	12	17	347
78000.W0340	Natural	400	26	57	M 8	17	12	17	445
78000.W0350	Natural	500	26	57	M 8	17	12	17	538



Cabinet Handles

aluminium, front mounting



Pull Handles

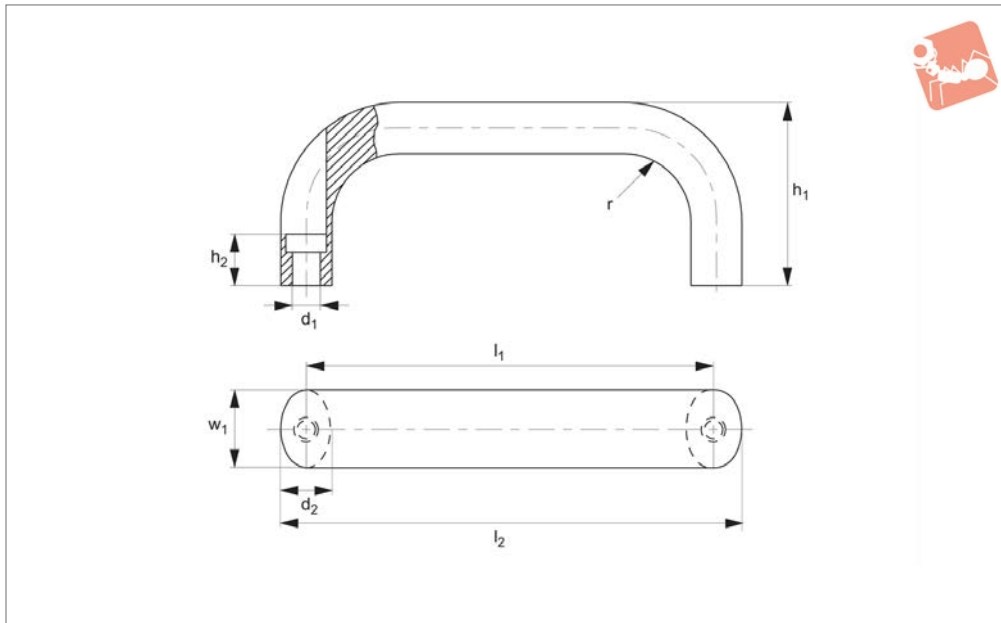

78010

PULL HANDLES

Material

Aluminium: plastic coated, black RAL 9005
Natural silver, bright.

Technical Notes

Ergonomic design offering high stability and smooth surfaces.

Order No.	Colour	l_1	w_1	h_1	d_1	d_2	l_2	h_2	For cylinder screw	r	Weight g
78010.W0100	Black	100	20	49	5.4	13	112	19	M 5	13	80
78010.W0103	Black	112	20	49	5.4	13	124	19	M 5	13	82
78010.W0106	Black	128	20	51	5.4	13	140	19	M 5	13	100
78010.W0109	Black	160	20	51	5.4	13	172	19	M 5	13	100
78010.W0111	Black	116	26	55	6.4	17	130	17	M 6	17	146
78010.W0113	Black	132	26	55	6.4	17	146	17	M 6	17	164
78010.W0116	Black	164	26	57	6.4	17	178	17	M 6	17	206
78010.W0119	Black	196	26	57	6.4	17	210	17	M 6	17	232
78010.W0300	Natural	100	20	49	5.4	13	112	19	M 5	13	80
78010.W0303	Natural	112	20	49	5.4	13	124	19	M 5	13	82
78010.W0306	Natural	128	20	51	5.4	13	140	19	M 5	13	100
78010.W0309	Natural	160	20	51	5.4	13	172	19	M 5	13	100
78010.W0311	Natural	116	26	55	6.4	17	130	17	M 6	17	146
78010.W0313	Natural	132	26	55	6.4	17	146	17	M 6	17	164
78010.W0316	Natural	164	26	57	6.4	17	178	17	M 6	17	206
78010.W0319	Natural	196	26	57	6.4	17	210	17	M 6	17	232
78010.W0511	Stainless	160	20	49	5.4	13	124	19	M5	13	258
78010.W0521	Stainless	128	20	49	5.4	13	140	19	M5	13	293
78010.W0531	Stainless	160	20	51	5.4	13	172	19	M5	13	345



78020

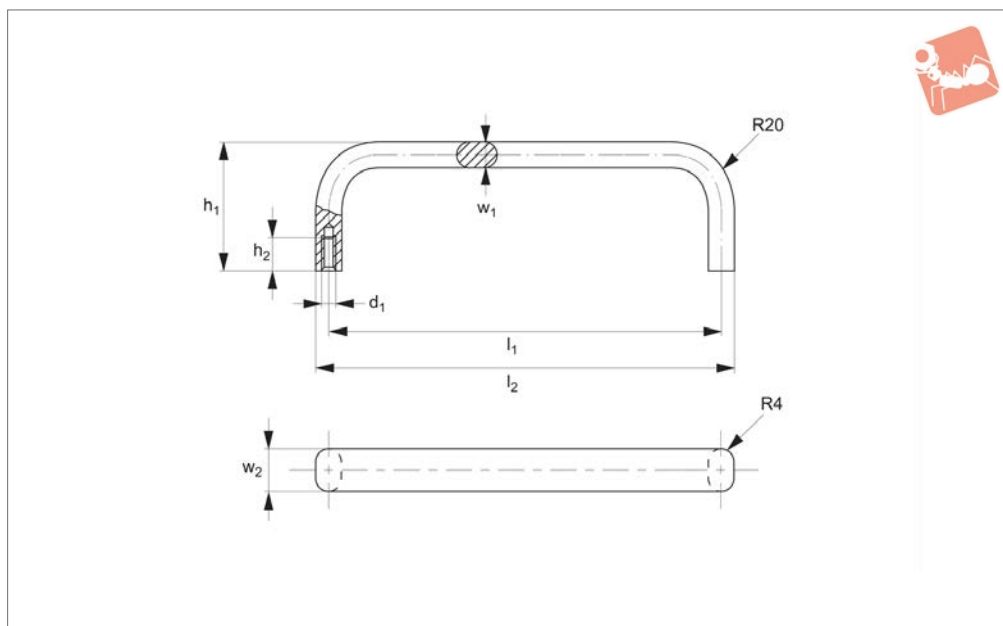

Material

Oval aluminium, Al Mg Si 0,5.

Finish: anodized with matt finish in natural

colour or black.

Technical Notes

Minimum stress resistance 500N.

Order No.	Colour	l_1	w_1	h_1	d_1	l_2	h_2	w_2
78020.W0055-1	Natural	55	8	40	M 5	63	10	12
78020.W0055-4	Black	55	8	40	M 5	63	10	12
78020.W0088-1	Natural	88	8	40	M 5	96	10	12
78020.W0088-4	Black	88	8	40	M 5	96	10	12
78020.W0100-1	Natural	100	8	40	M 5	108	10	12
78020.W0100-4	Black	100	8	40	M 5	108	10	12
78020.W0120-1	Natural	120	8	40	M 5	128	10	12
78020.W0120-4	Black	120	8	40	M 5	128	10	12
78020.W0180-1	Natural	180	8	40	M 5	180	10	12
78020.W0180-4	Black	180	8	40	M 5	188	10	12
78020.W0200-1	Natural	200	8	40	M 5	208	10	12
78020.W0200-4	Black	200	8	40	M 5	208	10	12
78020.W0235-1	Natural	235	8	40	M 5	243	10	12
78020.W0235-4	Black	235	8	40	M 5	243	10	12
78020.W0250-1	Natural	250	8	40	M 5	258	10	12
78020.W0250-4	Black	250	8	40	M 5	258	10	12



Pull Handles - Oval aluminium



Pull Handles

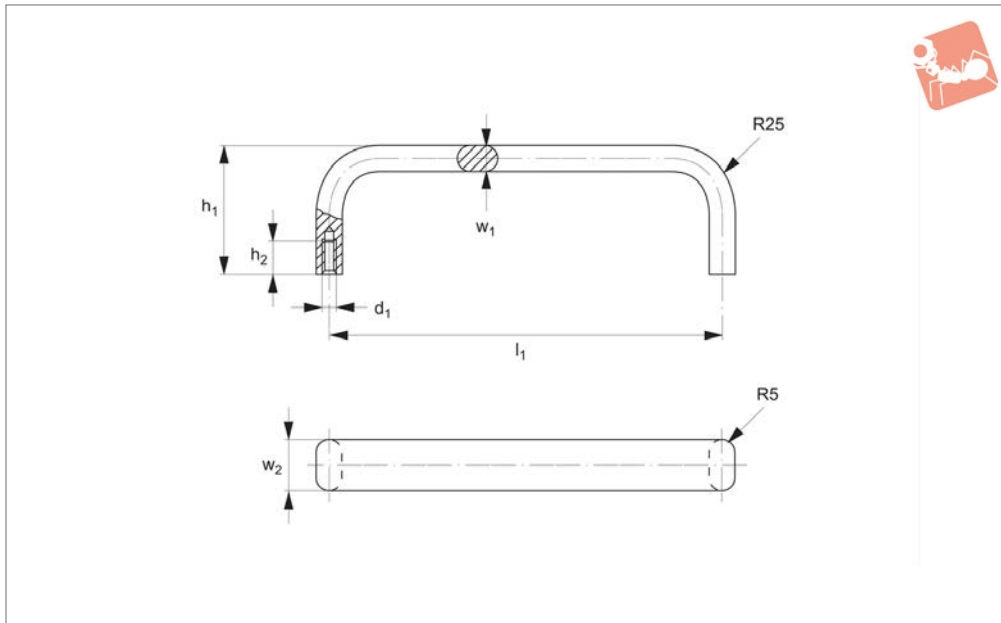

78030

PULL HANDLES

Material

Flat-oval profiled aluminium AlMgSi 0.5.
Finish: ground and anodized with a matte

finish in natural or black colour.

Technical Notes

Minimum stress resistance 500N. Suitable

for engineering, instrument and apparatus building.

Order No.	Colour	l_1	w_1	h_1	d_1	h_2	w_2
78030.W0120-1	Natural	120	10	45	5	10	20
78030.W0120-4	Black	120	10	45	5	10	20
78030.W0140-1	Natural	140	10	45	5	10	20
78030.W0140-4	Black	140	10	45	5	10	20
78030.W0180-1	Natural	180	10	45	5	10	20
78030.W0180-4	Black	180	10	45	5	10	20
78030.W0200-1	Natural	200	10	45	5	10	20
78030.W0200-4	Black	200	10	45	5	10	20
78030.W0350-1	Natural	350	10	45	6	12	20
78030.W0350-4	Black	350	10	45	6	12	20



78040

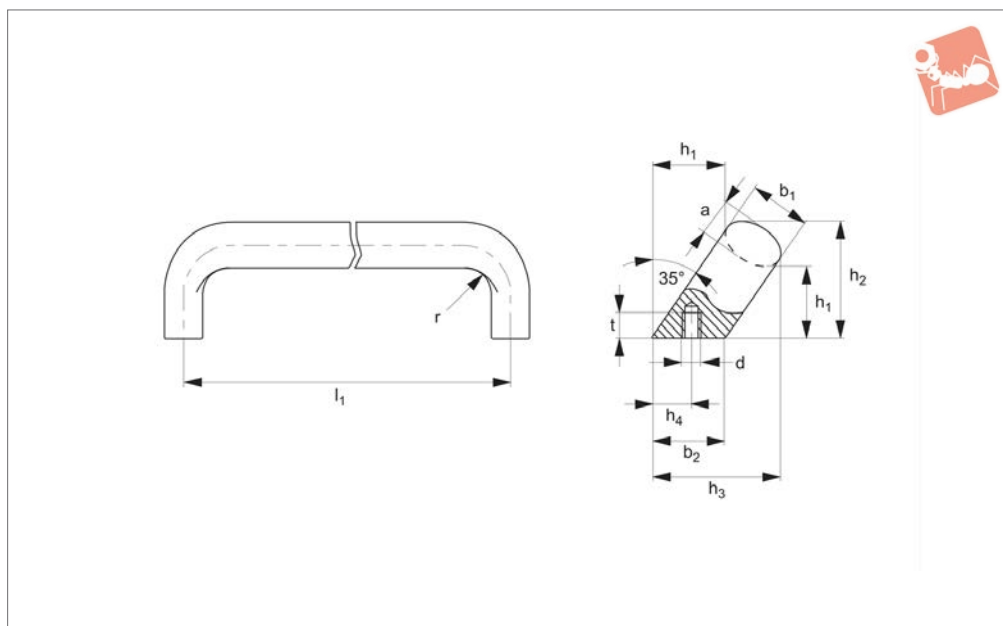

Material

Aluminium: natural silver - matt anodized, or plastic coated. Black - RAL 9005, matte,

textured finish.

Technical Notes

These handles feature modern and ergo-

nomic styling for a sure and comfortable grip. Handle inclined 35°.

Order No.	Finish	l_1	b_1	h_1	a	h_2	b_2	d	t min.	h_3	R	h_4 +1	Weight g
78040.W0004	Black	112	20	32	13	48	24	M_6	10	50	13	13.5	105
78040.W0006	Black	128	20	32	13	48	24	M_6	10	50	13	13.5	110
78040.W0008	Black	128	26	34	17	54	32	M_8	12	57	17	18.0	195
78040.W0018	Black	160	26	34	17	54	32	M_8	12	57	17	18.0	220
78040.W0104	Natural	112	20	32	13	48	24	M_6	10	50	13	13.5	99
78040.W0106	Natural	128	20	32	13	48	24	M_6	10	50	13	13.5	112
78040.W0108	Natural	128	26	34	17	54	32	M_8	12	57	17	18.0	190
78040.W0118	Natural	160	26	34	17	54	32	M_8	12	57	17	18.0	222

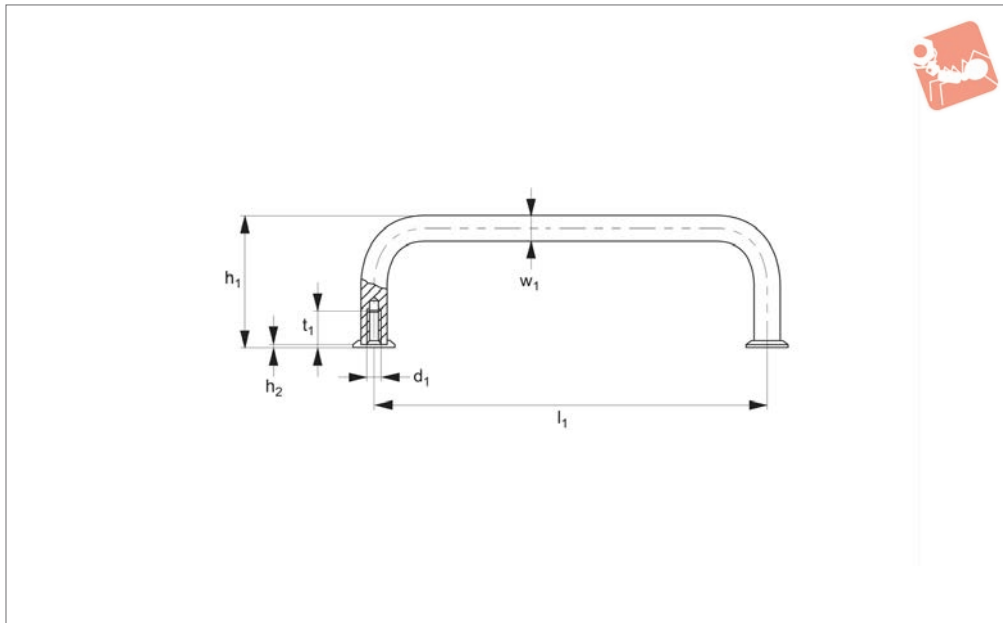

78050

PULL HANDLES

Material

Round bar aluminium dia. 10mm. Al Mg Si 0,5.

Finish: anodized with matt finish in natural colour or black.

Technical Notes

Minimum stress resistance 500N.

Order No.	Colour	l_1	w_1	h_1	d_1	t_1	h_2
78050.W0055-1	Natural	55	10	41	M 5	10	1
78050.W0055-4	Black	55	10	41	M 5	10	1
78050.W0088-1	Natural	88	10	41	M 5	10	1
78050.W0088-4	Black	88	10	41	M 5	10	1
78050.W0100-1	Natural	100	10	41	M 5	10	1
78050.W0100-4	Black	100	10	41	M 5	10	1
78050.W0120-1	Natural	120	10	41	M 5	10	1
78050.W0120-4	Black	120	10	41	M 5	10	1
78050.W0180-1	Natural	180	10	41	M 5	10	1
78050.W0180-4	Black	180	10	41	M 5	10	1
78050.W0200-1	Natural	200	10	41	M 5	10	1
78050.W0200-4	Black	200	10	41	M 5	10	1
78050.W0235-1	Natural	235	10	41	M 5	10	1
78050.W0235-4	Black	235	10	41	M 5	10	1
78050.W0250-1	Natural	250	10	41	M 5	10	1
78050.W0250-4	Black	250	10	41	M 5	10	1





Pull Handles - Offset aluminium

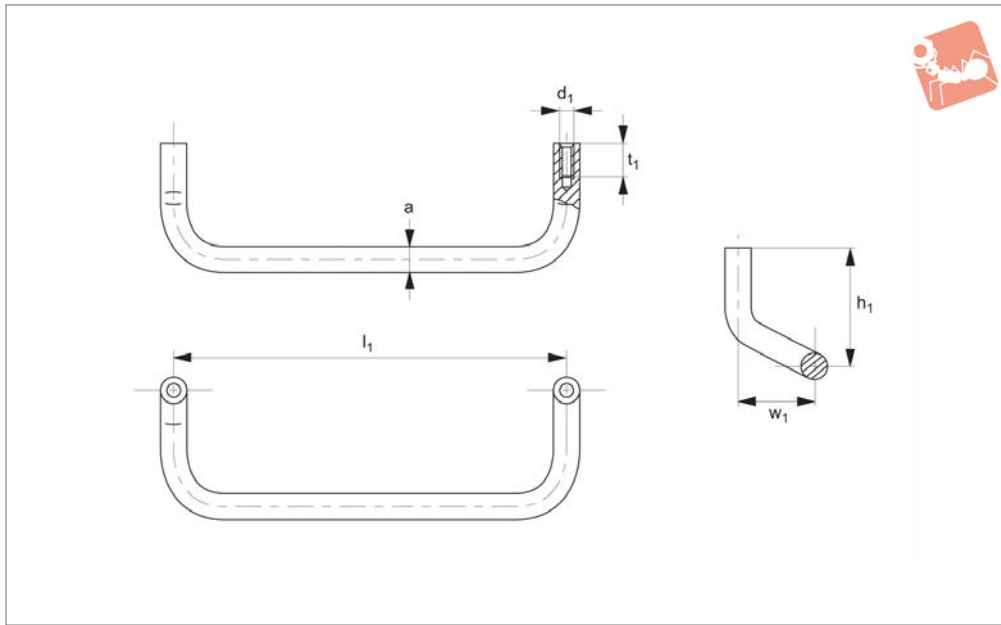

78070

PULL HANDLES

Material

Round aluminium bar, Al Mg Si 0,5. Finish: vibration ground, and anodized with a matt

finish in natural or black colour.

Technical Notes

Minimum stress resistance 500N.

Order No.	Finish	l_1	w_1	h_1	d_1	t_1	a
78070.W0086-1	Natural	86	30	40	M 5	10	10
78070.W0086-4	Black	86	30	40	M 5	10	10
78070.W0120-1	Natural	120	30	40	M 5	10	10
78070.W0120-4	Black	120	30	40	M 5	10	10
78070.W0180-1	Natural	180	30	40	M 5	10	10
78070.W0180-4	Black	180	30	40	M 5	10	10



78120

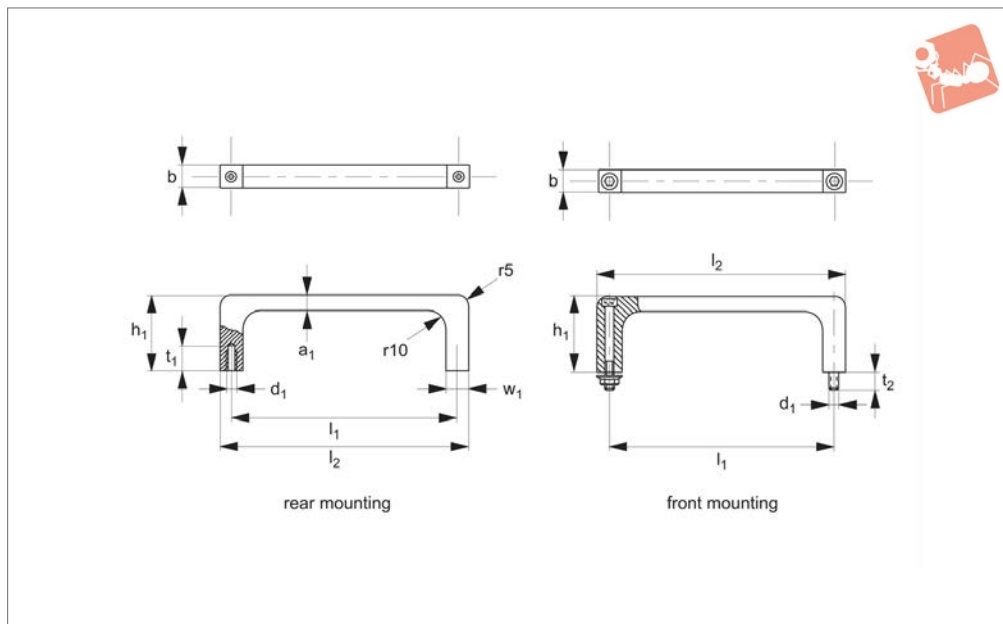

Material

Profile aluminium Al Mg Si 0,5.
Finish: vibration ground and anodized to a matt finish in natural or black colour.

Stainless steel hexagon screws to DIN 912, with self locking nuts, are supplied for front mounting type.

Technical Notes

Minimum stress resistance 500N.

Order No.	Finish	Type	l_1	w_1	b_1	h_1	d_1	l_2	h height of front panel	t_1	Mounting type	a_1	t_2
78120.W0005-1	Natural	Rear Mounting	55.0	12	12	40	M 5	67.0	88.1	10	1	8	9
78120.W0008-1	Natural	Rear Mounting	88.0	12	12	40	M 5	100.	132.5	10	1	8	9
78120.W0012-1	Natural	Rear Mounting	120.0	12	12	40	M 5	132.0	177.0	10	1	8	9
78120.W0018-1	Natural	Rear Mounting	180.0	12	12	40	M 5	192.0	221.5	10	1	8	9
78120.W0023-1	Natural	Rear Mounting	235.0	12	12	40	M 5	247.0	266.0	10	1	8	9
78120.W0505-1	Natural	Rear Mounting	32.0	12	12	40	M 5	43.5	44.0	10	2	8	9
78120.W0508-1	Natural	Rear Mounting	75.5	12	12	40	M 5	87.5	88.1	10	2	8	9
78120.W0512-1	Natural	Rear Mounting	120.0	12	12	40	M 5	132.0	132.5	10	2	8	9
78120.W0523-1	Natural	Rear Mounting	253.5	12	12	40	M 5	265.5	266.0	10	2	8	9
78120.W0005-4	Black	Rear Mounting	55.0	12	12	40	M 5	67.0	88.1	10	1	8	9
78120.W0008-4	Black	Rear Mounting	88.0	12	12	40	M 5	100.0	132.5	10	1	8	9
78120.W0012-4	Black	Rear Mounting	120.0	12	12	40	M 5	132.0	177.0	10	1	8	9
78120.W0018-4	Black	Rear Mounting	180.0	12	12	40	M 5	192.0	221.5	10	1	8	9
78120.W0023-4	Black	Rear Mounting	235.0	12	12	40	M 5	247.0	266.0	10	1	8	9
78120.W0505-4	Black	Rear Mounting	32.0	12	12	40	M 5	43.5	44.0	10	2	8	9
78120.W0508-4	Black	Rear Mounting	75.5	12	12	40	M 5	87.5	88.1	10	2	8	9
78120.W0512-4	Black	Rear Mounting	120.0	12	12	40	M 5	132.0	132.5	10	2	8	9
78120.W0523-4	Black	Rear Mounting	253.5	12	12	40	M 5	265.5	266.0	10	2	8	9
78120.W0105-1	Natural	Front Mounting	55.0	12	12	40	M 5	67.0	88.1	10	1	8	9
78120.W0108-1	Natural	Front Mounting	88.0	12	12	40	M 5	100.	132.5	10	1	8	9
78120.W0112-1	Natural	Front Mounting	120.0	12	12	40	M 5	132.0	177.0	10	1	8	9
78120.W0118-1	Natural	Front Mounting	180.0	12	12	40	M 5	192.0	221.5	10	1	8	9
78120.W0123-1	Natural	Front Mounting	235.0	12	12	40	M 5	247.0	266.0	10	1	8	9
78120.W0605-1	Natural	Front Mounting	32.0	12	12	40	M 5	43.5	44.0	10	2	8	9
78120.W0608-1	Natural	Front Mounting	75.5	12	12	40	M 5	87.5	88.1	10	2	8	9
78120.W0612-1	Natural	Front Mounting	120.0	12	12	40	M 5	132.0	132.5	10	2	8	9
78120.W0623-1	Natural	Front Mounting	253.5	12	12	40	M 5	265.5	266.0	10	2	8	9
78120.W0105-4	Black	Front Mounting	55.0	12	12	40	M 5	67.0	88.1	10	1	8	9
78120.W0108-4	Black	Front Mounting	88.0	12	12	40	M 5	100.0	132.5	10	1	8	9
78120.W0112-4	Black	Front Mounting	120.0	12	12	40	M 5	132.0	177.0	10	1	8	9
78120.W0118-4	Black	Front Mounting	180.0	12	12	40	M 5	192.0	221.5	10	1	8	9
78120.W0123-4	Black	Front Mounting	235.0	12	12	40	M 5	247.0	266.0	10	1	8	9
78120.W0605-4	Black	Front Mounting	32.0	12	12	40	M 5	43.5	44.0	10	2	8	9
78120.W0608-4	Black	Front Mounting	75.5	12	12	40	M 5	87.5	88.1	10	2	8	9
78120.W0612-4	Black	Front Mounting	120.0	12	12	40	M 5	132.0	132.5	10	2	8	9



Pull Handles - Aluminium

for 19" drawers and instrument panels



Pull Handles

Order No.	Finish	Type	l_1	w_1	b_1	h_1	d_1	l_2	h height of front panel	t_1	Mounting type	a_1	t_2
78120.W0623-4	Black	Front Mounting	253.5	12	12	40	M 5	265.5	266.0	10	2	8	9

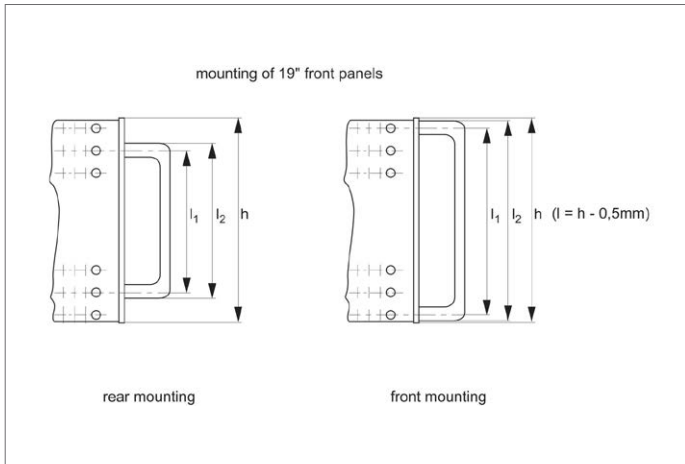



78130

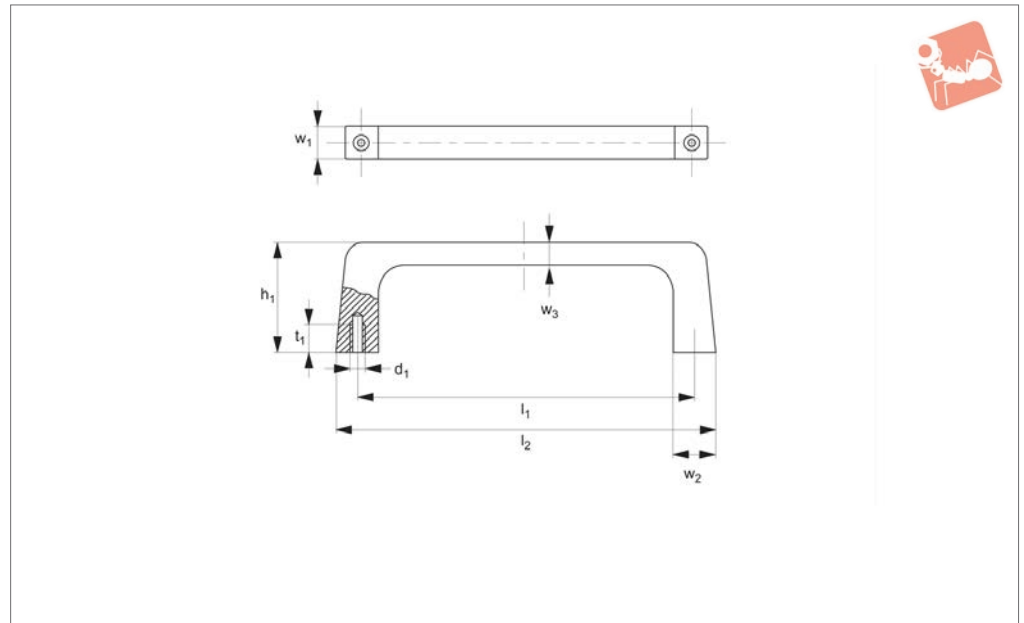

Material

Cut profiled aluminium AIMgSi 0.5.
Finish: anodized with a matt finish in

natural colour or black.

Technical Notes

Minimum stress resistance 500N.

Order No.	Colour	l_1	w_1	h_1	d_1	l_2	t_1	w_2	w_3	Suitable mounting Version	Height of front panel h
78130.W0025-1	Natural	25.0	12	40	M 5	40.0	10	12	5	1	44.0
78130.W0025-4	Black	25.0	12	40	M 5	40.0	10	12	5	1	44.0
78130.W0055-1	Natural	55.0	12	40	M 5	69.0	10	12	8	1	88.1
78130.W0055-4	Black	55.0	12	40	M 5	69.0	10	12	8	1	88.1
78130.W0088-1	Natural	88.0	12	40	M 5	102.0	10	12	8	1	132.5
78130.W0088-4	Black	88.0	12	40	M 5	102.0	10	12	8	1	132.5
78130.W0120-1	Natural	120.0	12	40	M 5	134.0	10	12	8	1	177.0
78130.W0120-4	Black	120.0	12	40	M 5	134.0	10	12	8	1	177.0
78130.W0133-1	Natural	133.4	12	40	M 5	146.5	10	12	8	-	-
78130.W0133-4	Black	133.4	12	40	M 5	146.5	10	12	8	-	-
78130.W0177-1	Natural	177.8	12	40	M 5	191.0	10	12	8	-	-
78130.W0177-4	Black	177.8	12	40	M 5	191.0	10	12	8	-	-
78130.W0180-1	Natural	180.0	12	40	M 5	194.0	10	12	8	1	221.5
78130.W0180-4	Black	180.0	12	40	M 5	194.0	10	12	8	1	221.5
78130.W0235-1	Natural	235.0	12	40	M 5	249.0	10	12	8	1	266.0
78130.W0235-4	Black	235.0	12	40	M 5	249.0	10	12	8	1	266.0
78130.W0251-1	Natural	251.5	12	40	M 5	265.5	10	12	8	2	266.0
78130.W0251-4	Black	251.5	12	40	M 5	265.5	10	12	8	2	266.0
78130.W0588-1	Natural	88.0	12	46	M 5	102.0	10	12	8	1	132.5
78130.W0588-4	Black	88.0	12	46	M 5	102.0	10	12	8	1	132.5
78130.W0620-1	Natural	120.0	12	46	M 5	132.0	10	12	8	2	132.5
78130.W0620-4	Black	120.0	12	46	M 5	132.0	10	12	8	2	132.5



Pull Handles - Aluminium for 19" drawers and instrument panels

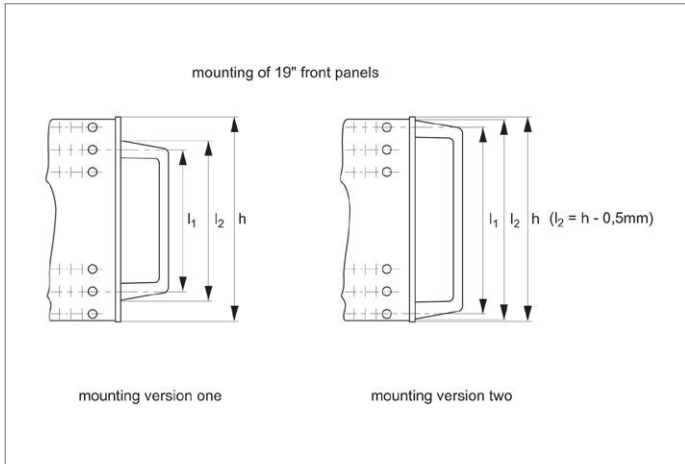



78180

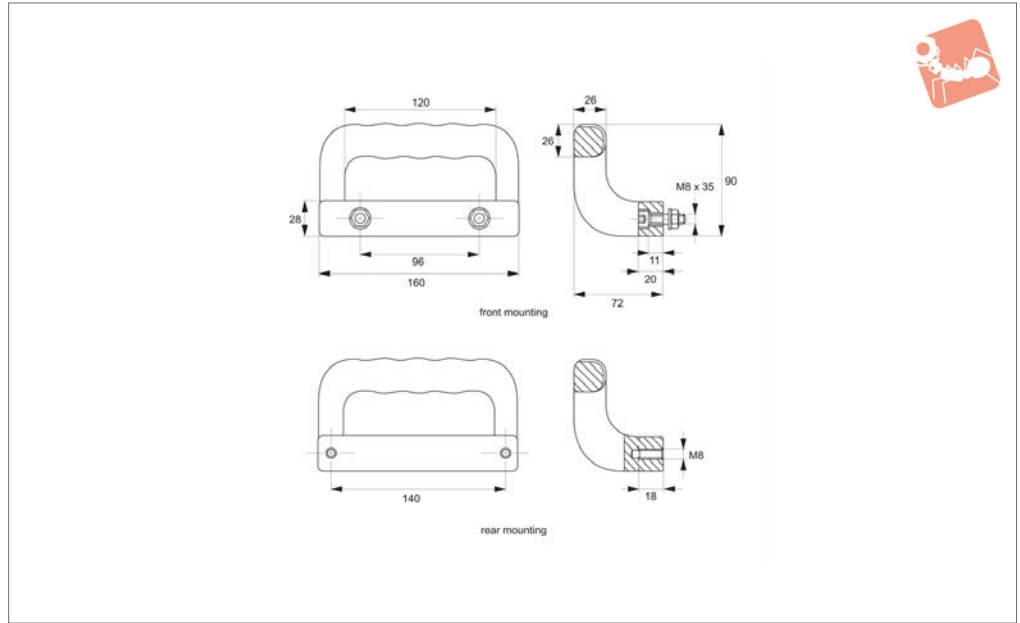

Material

Die cast aluminium AlSiCu 12.
Finish: vibration ground and black powder coated, semi-matt.

Technical Notes

Front mounting version comes with stainless steel hexagon socket head cap screw DIN M 8x35, nuts DIN 934 and washers

DIN125.

Stress resistance: 1000N.

Order No.	Type
78180.W0096	Front Mounting
78180.W0140	Rear Mounting

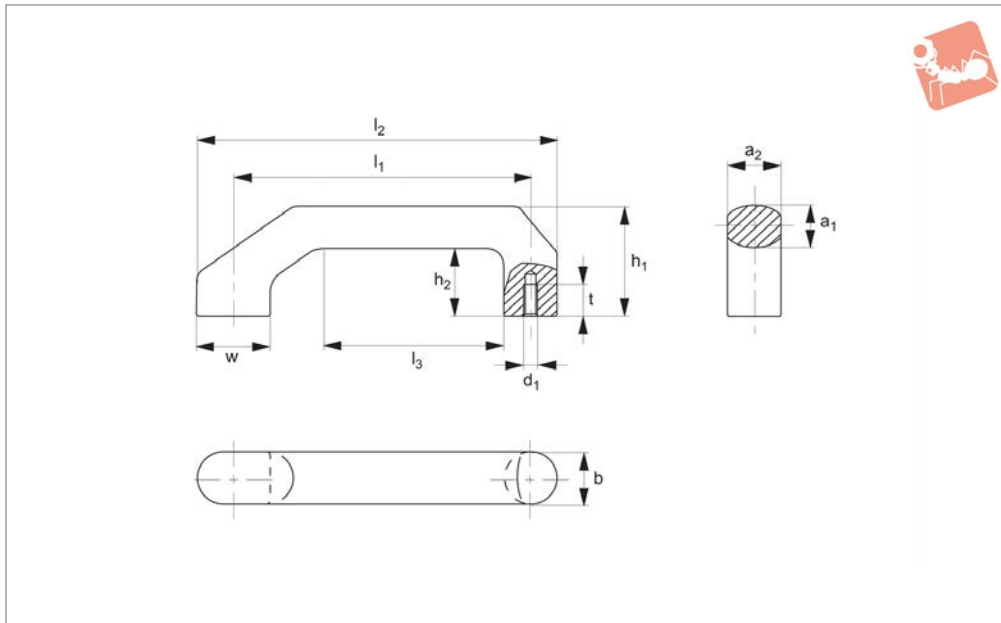

78200

PULL HANDLES

Material

Die cast aluminium AlMg3.

Finish: vibration ground, raw or black

powder coated, semi-matt.

Technical Notes

Stress resistance: min. 500N.

Order No.	Finish	l_1	h_1	d_1	l_2	h_2	l_3	t	a_1	a_2	w	b
78200.W0140-1	Natural	140	52	M 6	170	32	89	15	20	25	35	25
78200.W0140-4	Black	140	52	M 6	170	32	89	15	20	25	35	25



78210

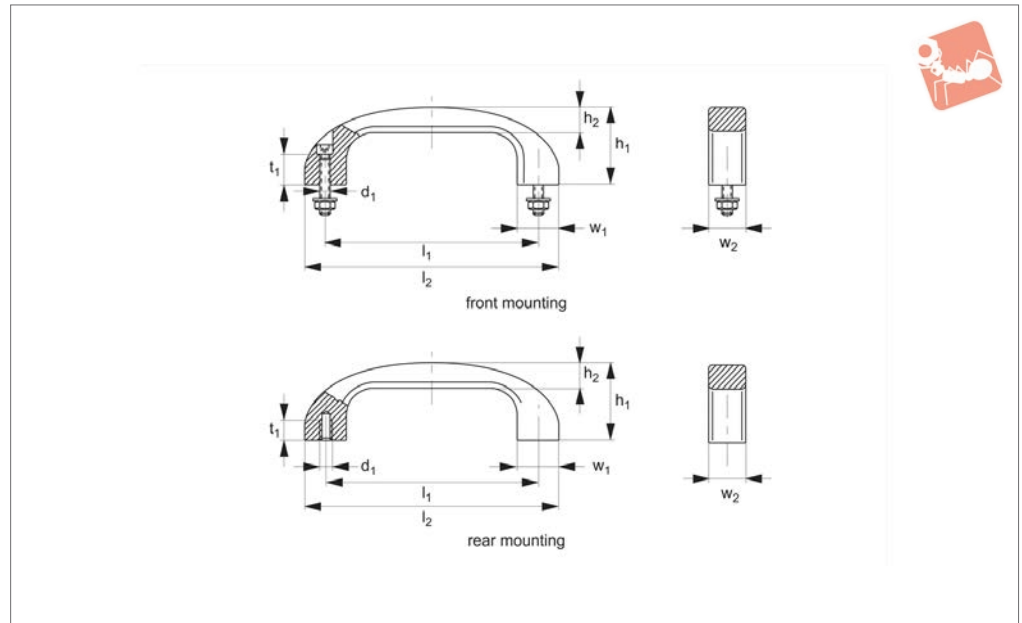

Material

Aluminium section AlMgSi 0.5. Finish: anodized in a special quality glass ball blasted, satin finish.

Technical Notes

Minimum stress resistance <1000N.
Front mounted version supplied with cheese head screws (with hex socket) DIN

912, nuts DIN 934 and washer DIN125 - made of made os stainless steel.

Order No.	Colour	Type	l_1	w_1	h_1	d_1	l_2	t_1	h_2	w_2
78210.W0120-1	Natural	Rear Mounting	120	24	46	M 6	144	12	15	22
78210.W0120-4	Black	Rear Mounting	120	24	46	M 6	144	12	15	22
78210.W0140-1	Natural	Rear Mounting	140	28	53	M 8	168	12	17	25
78210.W0140-4	Black	Rear Mounting	140	28	53	M 8	168	12	17	25
78210.W0220-1	Natural	Front Mounting	120	24	46	M 6x25	144	15	15	22
78210.W0220-4	Black	Front Mounting	120	24	46	M 6x25	144	15	15	22
78210.W0240-1	Natural	Front Mounting	140	28	53	M 8x30	168	15	17	25
78210.W0240-4	Black	Front Mounting	140	28	53	M 8x30	168	15	17	25



Pull Handles - Grip type aluminium

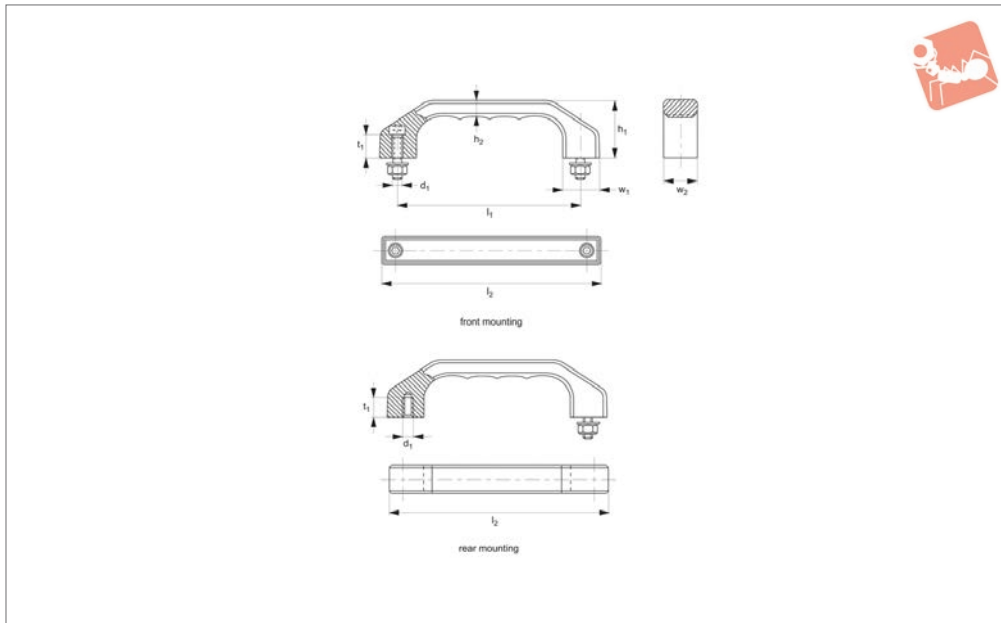

78240

PULL HANDLES

Material

Aluminium section AlMgSi 0.5. Finish: anodized in a special quality, glass ball blasted, satin finish. RHL 9002, grey,

white.

design. Minimum stress resistance >1000N.

Technical Notes

Solid aluminium handles in industrial

Order No.	Colour	Type	l_1	w_1	h_1	d_1	l_2	t_1	h_2	w_2
78240.W0120-1	Natural	Rear Mounting	120	24	39	M 6	146	12	10.5	22
78240.W0120-4	Black	Rear Mounting	120	24	39	M 6	146	12	10.5	22
78240.W0140-1	Natural	Rear Mounting	140	28	45	M 8	170	15	12.0	25
78240.W0140-4	Black	Rear Mounting	140	28	45	M 8	170	15	12.0	25
78240.W0160-1	Natural	Rear Mounting	160	32	52	M 8	194	15	13.5	28
78240.W0160-4	Black	Rear Mounting	160	32	52	M 8	194	15	13.5	28
78240.W0220-1	Natural	Front Mounting	120	24	39	M 6	146	12	10.5	22
78240.W0220-4	Black	Front Mounting	120	24	39	M 6	146	12	10.5	22
78240.W0240-1	Natural	Front Mounting	140	28	45	M 8	170	15	12.0	25
78240.W0240-4	Black	Front Mounting	140	28	45	M 8	170	15	12.0	25
78240.W0260-1	Natural	Front Mounting	160	32	52	M 8	194	15	13.5	28
78240.W0260-4	Black	Front Mounting	160	32	52	M 8	194	15	13.5	28

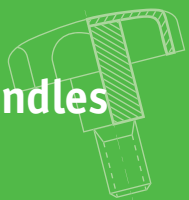

78700

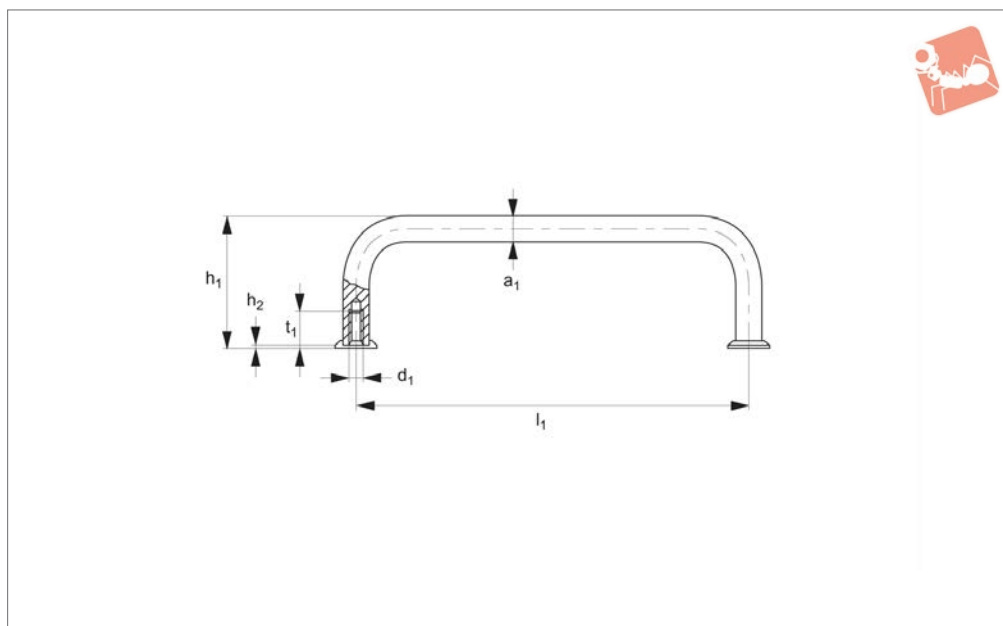

Material

Round steel bar.
Finish: precision ground and high gloss

chromium plated surface. Chromium
coloured brass cover washers included.

Technical Notes

Minimum stress resistance 1000N.

Order No.	l_1	$\varnothing a_1$	d_1	h_1	h_2	t_1
78700.W0003	32	5	M 3	21	1	6
78700.W0004	42	5	M 3	25	1	6
78700.W0005	55	5	M 3	25	1	6
78700.W0007	76	5	M 3	25	1	6
78700.W0008	88	5	M 3	25	1	6
78700.W0103	32	8	M 4	33	1	8
78700.W0105	55	8	M 4	33	1	8
78700.W0106	64	8	M 4	33	1	8
78700.W0108	88	8	M 4	33	1	8
78700.W0109	96	8	M 4	33	1	8
78700.W0110	102	8	M 4	33	1	8
78700.W0112	120	8	M 4	33	1	8
78700.W0113	128	8	M 4	33	1	8
78700.W0114	136	8	M 4	33	1	8
78700.W0505	55	10	M 5	41	1	10
78700.W0508	88	10	M 5	41	1	10
78700.W0509	100	10	M 5	41	1	10
78700.W0510	102	10	M 5	41	1	10
78700.W0511	115	10	M 5	41	1	10
78700.W0512	120	10	M 5	41	1	10
78700.W0514	136	10	M 5	41	1	10
78700.W0518	180	10	M 5	41	1	10
78700.W0520	200	10	M 5	41	1	10
78700.W0523	235	10	M 5	41	1	10
78700.W0525	250	10	M 5	41	1	10

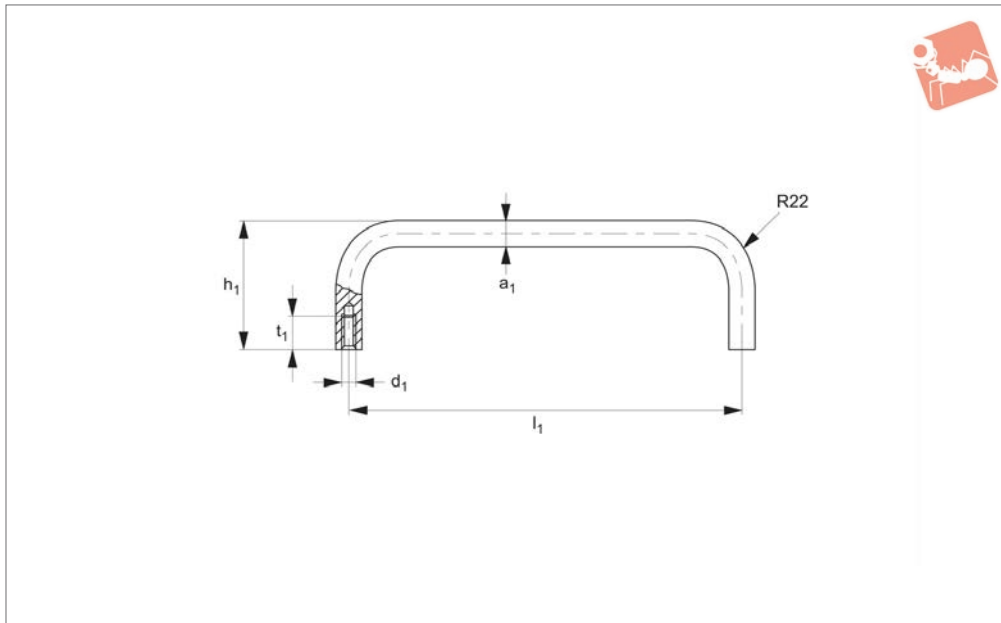

78720

PULL HANDLES

Material

Round steel bar $\varnothing 20\text{mm}$.
Finish: ground, brushed matt chromium

plated or black powder coated.

Technical Notes

Minimum stress resistance >1000N.

Order No.	Finish	l_1	a_1	d_1	h_1	t_1
78720.W0200-1	Matte Chromium Plated	200	20	M 8	70	15
78720.W0250-1	Matte Chromium Plated	250	20	M 8	70	15
78720.W0300-1	Matte Chromium Plated	300	20	M 8	70	15
78720.W0350-1	Matte Chromium Plated	350	20	M 8	70	15
78720.W0400-1	Matte Chromium Plated	400	20	M 8	70	15
78720.W0200-4	Black Powder Coated	200	20	M 8	70	15
78720.W0250-4	Black Powder Coated	250	20	M 8	70	15
78720.W0300-4	Black Powder Coated	300	20	M 8	70	15
78720.W0350-4	Black Powder Coated	350	20	M 8	70	15
78720.W0400-4	Black Powder Coated	400	20	M 8	70	15





78740

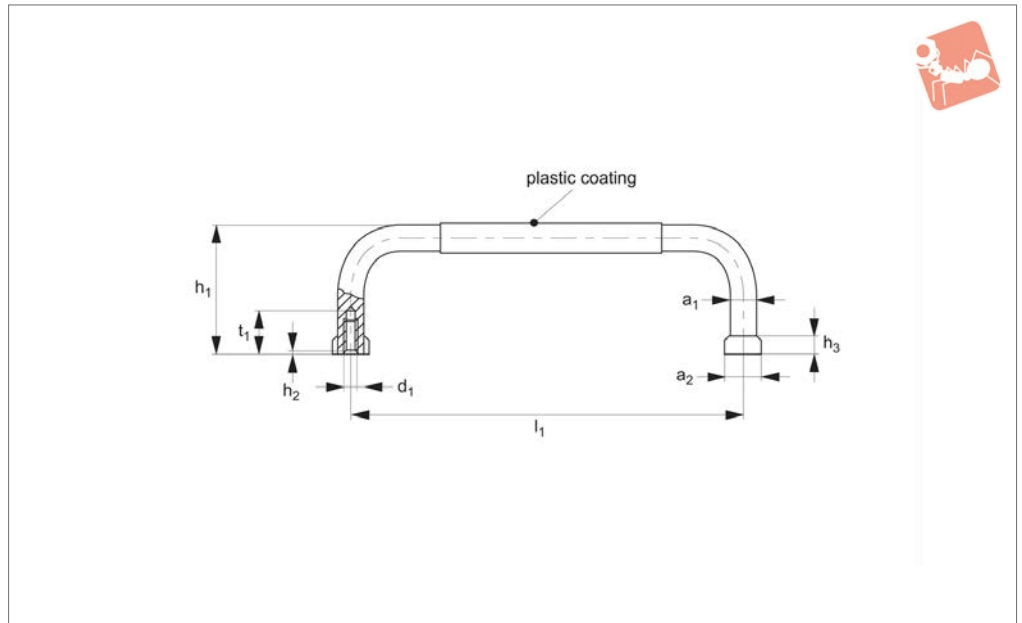

Material

Round steel bar.

Finish: precision ground and matt gloss chromium plated surface, handle arms with smooth plastic covering. High quality

handles for front panels and similar applications.

Technical Notes

Matte gloss chromium plated brass end

bushes included. Minimum stress resistance 1000N.

Order No.	l_1	a_1	a_2	d_1	h_1	h_2	h_3	t_1
78740.W0005	55	10	14	M 5	41	1	8	10
78740.W0088	88	10	14	M 5	41	1	8	10
78740.W0100	100	10	14	M 5	41	1	8	10
78740.W0102	102	10	14	M 5	41	1	8	10
78740.W0115	115	10	14	M 5	41	1	8	10
78740.W0120	120	10	14	M 5	41	1	8	10
78740.W0136	136	10	14	M 5	41	1	8	10
78740.W0180	180	10	14	M 5	41	1	8	10
78740.W0200	200	10	14	M 5	41	1	8	10
78740.W0235	235	10	14	M 5	41	1	8	10
78740.W0250	250	10	14	M 5	41	1	8	10



Pull Handles - Cranked steel

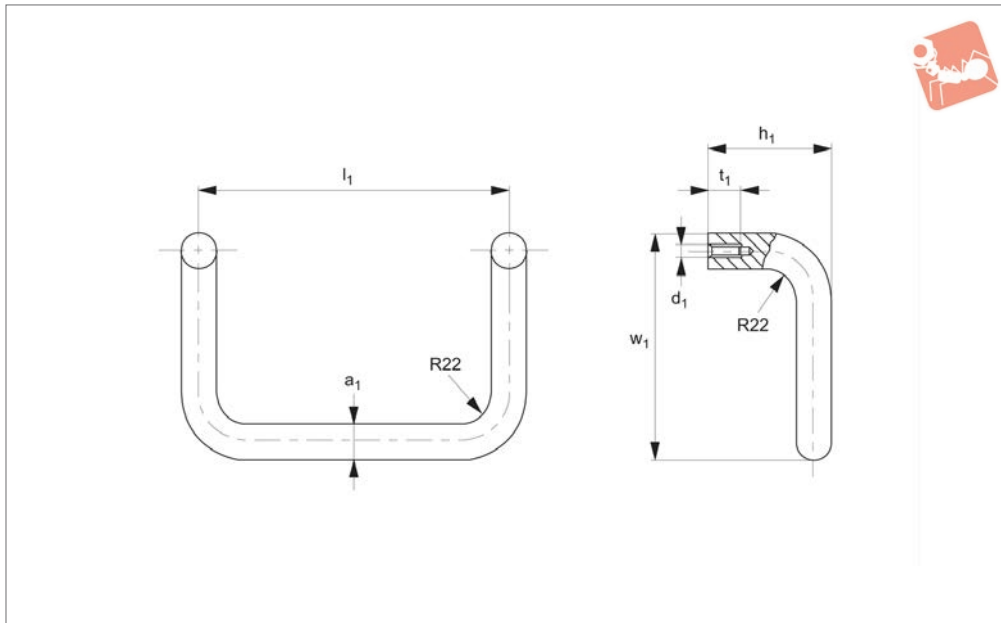

78760

PULL HANDLES

Material

Round bar steel, Ø20mm.
Finish: ground, brushed matt chromium plated or black powder coated with fine

structure.

Technical Notes

Minimum stress resistance >1000N.

Handles with other bore clearances are available on request.

Order No.	Finish	l_1	a_1	d_1	h_1	t_1	w_1
78760.W0200-1	Matte Chromium Plated	200	20	M 8	70	15	130
78760.W0200-4	Black Powder Coated	200	20	M 8	70	15	130
78760.W0350-1	Matte Chromium Plated	350	20	M 8	70	15	130
78760.W0350-4	Black Powder Coated	350	20	M 8	70	15	130



78770

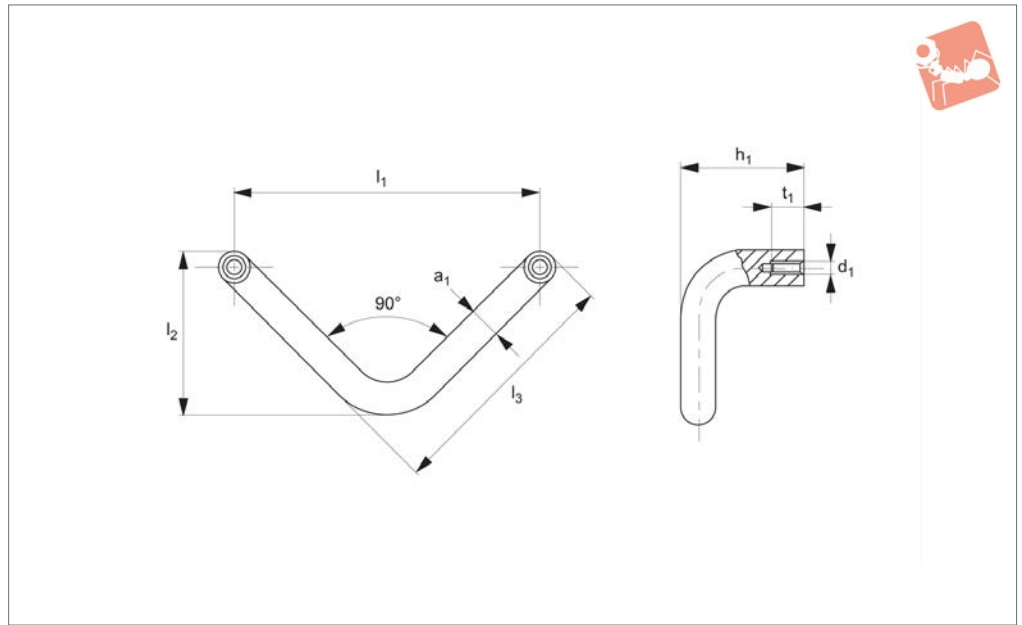

PULL HANDLES

Material

Round steel bar.
Finish: polished and bright chromium-

plated surface finish.

resistance 500N.

Technical Notes

Concentric threaded hole. Minimum stress

Order No.	l_1	a_1	d_1	h_1	l_2	l_3	t_1
78770.W0075	75	8	M_4	32	41	61	8
78770.W0090	90	10	M_5	40	49	73	10

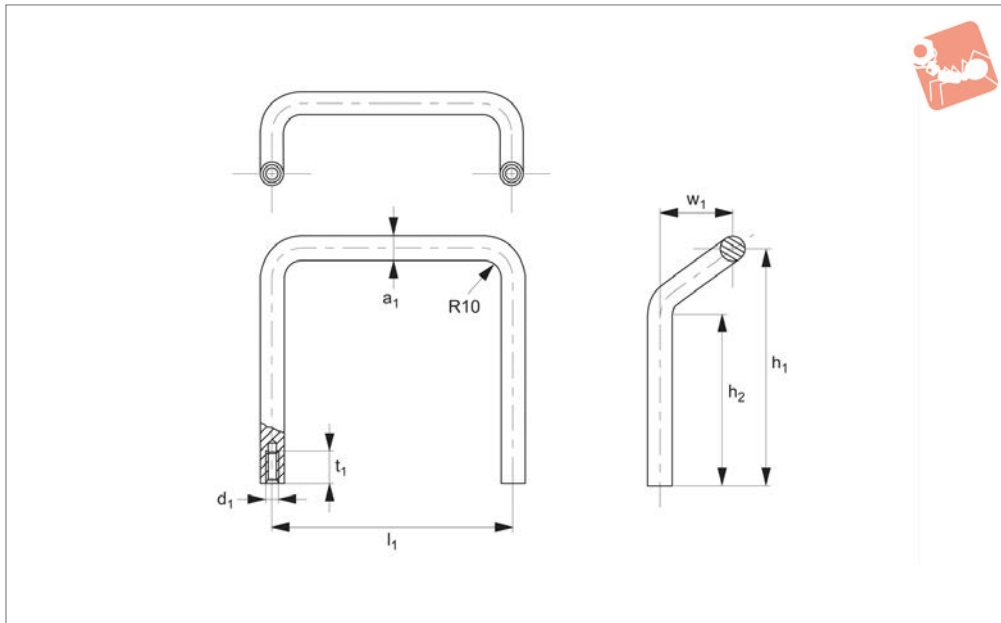

78780

PULL HANDLES

Material

Round bar steel, 12mm.
Finish: precision-ground and chromium-

plated mirror finish.

Technical Notes

Minimum stress resistance 1000N. Addi-

tional sizes or surface versions on request.

Order No.	l_1	a_1	d_1	h_1	h_2	t_1	w_1
78780.W0060	120	12	M 8	60	27	15	35
78780.W0120	120	12	M 8	120	87	15	35



78800

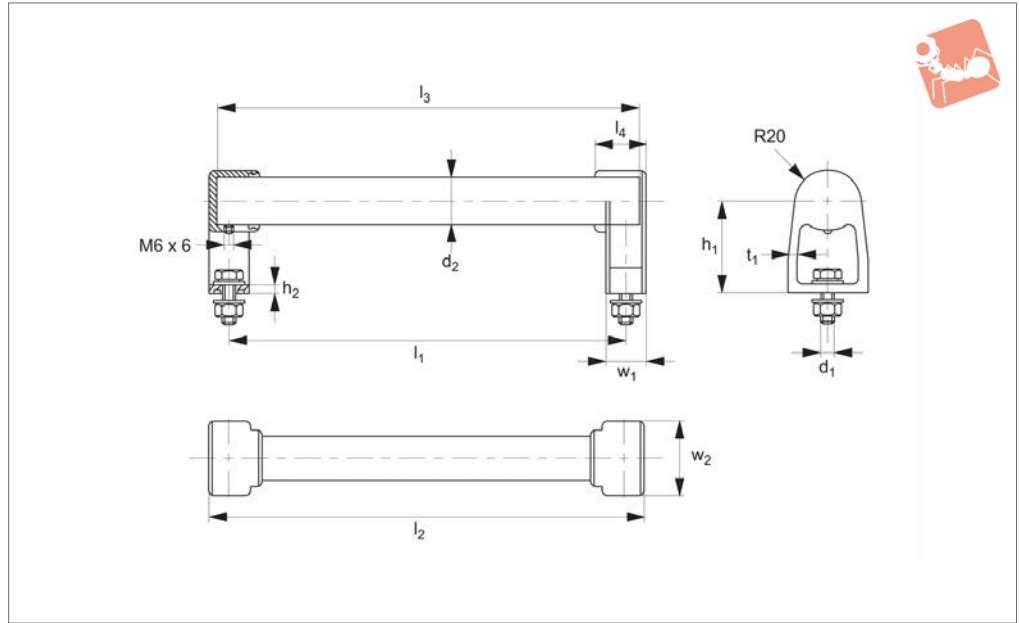

PULL HANDLES

Material

Handle shank: cast stainless steel, G-X7 CrNiMoNb 18 10. Glass blasted, satin matt finish.

Connecting tube: stainless steel, X5 CrNi189, 1.4301. Ground and blasted.

Packing ring: food quality silicon rubber.

Technical Notes

Standard mounting type (front or rear): with hex screws to DIN 933, M 8x25, washers & nuts.

Safety mounting type (rear only): with bolts to DIN603, M8x25, washers & nuts. Long term temperature resistance -60°C to + 200°C. Minimum stress resistance >1000N.

Ideal for use in food industry applications.

Order No.	Mounting type	l_1	l_2	l_3	l_4	d_1	d_2 dia.	h_1	h_2	t_1	w_1	w_2
78800.W0200	Standard	200	225	215	32	M 8x25	30x1,5	60	5	5	25	48
78800.W0210	Safety	200	225	215	32	M 8x25	30x1,5	60	5	5	25	48
78800.W0250	Standard	250	275	265	32	M 8x25	30x1,5	60	5	5	25	48
78800.W0260	Safety	250	275	265	32	M 8x25	30x1,5	60	5	5	25	48
78800.W0300	Standard	300	325	315	32	M 8x25	30x1,5	60	5	5	25	48
78800.W0310	Safety	300	325	315	32	M 8x25	30x1,5	60	5	5	25	48
78800.W0350	Standard	350	375	365	32	M 8x25	30x1,5	60	5	5	25	48
78800.W0360	Safety	350	375	365	32	M 8x25	30x1,5	60	5	5	25	48
78800.W0400	Standard	400	425	415	32	M 8x25	30x1,5	60	5	5	25	48
78800.W0410	Safety	400	425	415	32	M 8x25	30x1,5	60	5	5	25	48
78800.W0500	Standard	500	525	515	32	M 8x25	30x1,5	60	5	5	25	48
78800.W0510	Safety	500	525	515	32	M 8x25	30x1,5	60	5	5	25	48
78800.W0600	Standard	600	625	615	32	M 8x25	30x1,5	60	5	5	25	48
78800.W0610	Safety	600	625	615	32	M 8x25	30x1,5	60	5	5	25	48

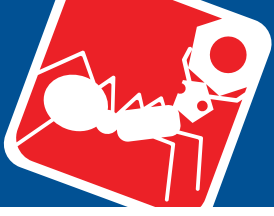

Pull Handles

stainless steel



PULL HANDLES



78820

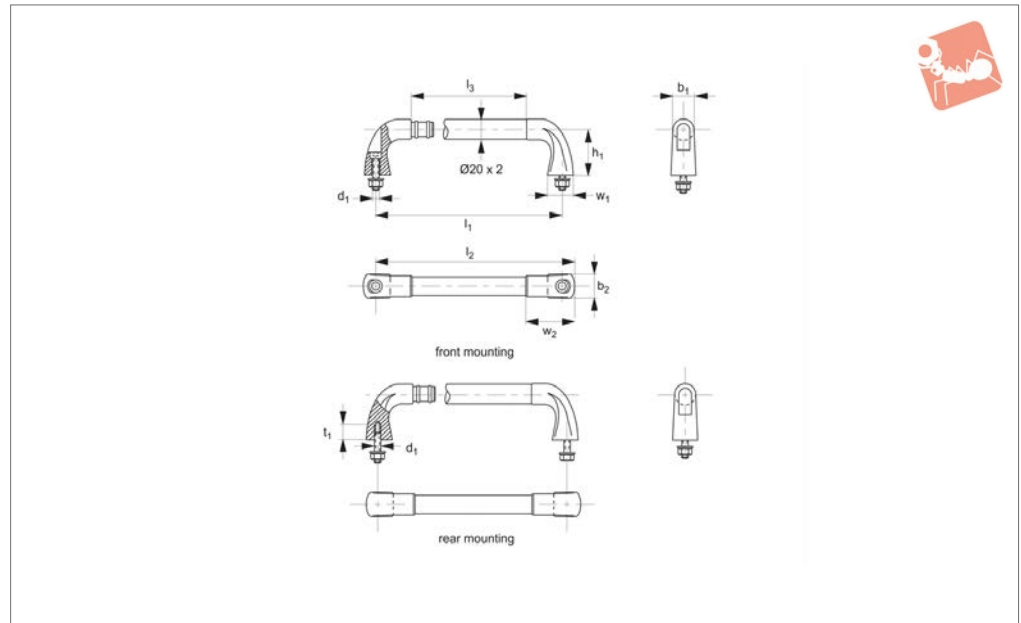

Material

Handle shank: cast stainless steel, Gx7 CrNiMoNb 18 10, abrasive blasted and electro-polished, dull bright finish.
 Connecting tube: stainless steel x5 CrNi 189, 1.4301. Precision ground or grooved plastic coating.

Connection tubes finish grounded and brushed. Handle shanks glass blasted and electro polished with half matte finish.

to DIN 912, M 8x35 and suitable washer and nut. Rear Mounting: supplied with hex screws to DIN 913 and suitable washer. Minimum stress resistance >1000N.

Technical Notes

Front mounting: supplied with hex screws

Order No.	Tube finish	Type	l_1	l_2	l_3	b_1	b_2	d_1	h_1	t_1	w_1	w_2
78820.W0020	Natural	Front Mount	200	226	120	22	26	M 8 x 35	50	-	29	53
78820.W0025	Natural	Front Mount	250	276	170	22	26	M 8 x 35	50	-	29	53
78820.W0030	Natural	Front Mount	300	326	220	22	26	M 8 x 35	50	-	29	53
78820.W0035	Natural	Front Mount	350	376	270	22	26	M 8 x 35	50	-	29	53
78820.W0040	Natural	Front Mount	400	426	320	22	26	M 8 x 35	50	-	29	53
78820.W0120	Plastic Covered	Front Mount	200	226	120	22	26	M 8 x 35	50	-	29	53
78820.W0125	Plastic Covered	Front Mount	250	276	170	22	26	M 8 x 35	50	-	29	53
78820.W0130	Plastic Covered	Front Mount	300	326	220	22	26	M 8 x 35	50	-	29	53
78820.W0135	Plastic Covered	Front Mount	350	376	270	22	26	M 8 x 35	50	-	29	53
78820.W0140	Plastic Covered	Front Mount	400	426	320	22	26	M 8 x 35	50	-	29	53
78820.W0520	Natural	Rear Mount	200	226	120	22	26	M 8 x 20	50	16	29	53
78820.W0525	Natural	Rear Mount	250	276	170	22	26	M 8 x 20	50	16	29	53
78820.W0530	Natural	Rear Mount	300	326	220	22	26	M 8 x 20	50	16	29	53
78820.W0535	Natural	Rear Mount	350	376	270	22	26	M 8 x 20	50	16	29	53
78820.W0540	Natural	Rear Mount	400	426	320	22	26	M 8 x 20	50	16	29	53
78820.W0620	Plastic Covered	Rear Mount	200	226	120	22	26	M 8 x 20	50	16	29	53
78820.W0625	Plastic Covered	Rear Mount	250	276	170	22	26	M 8 x 20	50	16	29	53
78820.W0630	Plastic Covered	Rear Mount	300	326	220	22	26	M 8 x 20	50	16	29	53
78820.W0635	Plastic Covered	Rear Mount	350	376	270	22	26	M 8 x 20	50	16	29	53
78820.W0640	Plastic Covered	Rear Mount	400	426	320	22	26	M 8 x 20	50	16	29	53

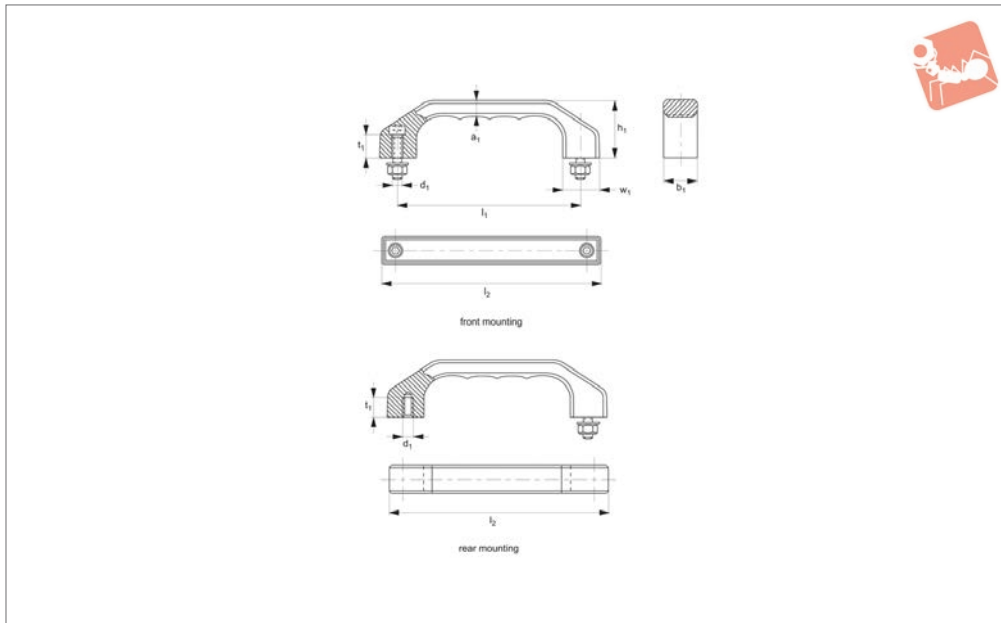

78830

PULL HANDLES

Material

Stainless steel (304) precision casting (G X6 CrNi 18 9, material no. G4308). Finish: blasted and electropolished with a semi-

matt finish.

Technical Notes

Front mounting: supplied with hex screws

to DIN 912, and suitable washer and nut. Rear Mounting: supplied with hex head screws to DIN 933 and suitable washer. Minimum stress resistance >1000N.

Order No.	Type	l_1	l_2	a_1	b_1	d_1	h_1	t_1	w_1
78830.W0140	Front Mounting	140	170	12	25	M_8x30	45	15	28
78830.W0180	Front Mounting	180	218	15	32	M10x40	58	18	36
78830.W0540	Rear Mounting	140	170	12	25	M_8x18	45	15	28
78830.W0580	Rear Mounting	180	218	15	32	M10x20	58	18	36



78850

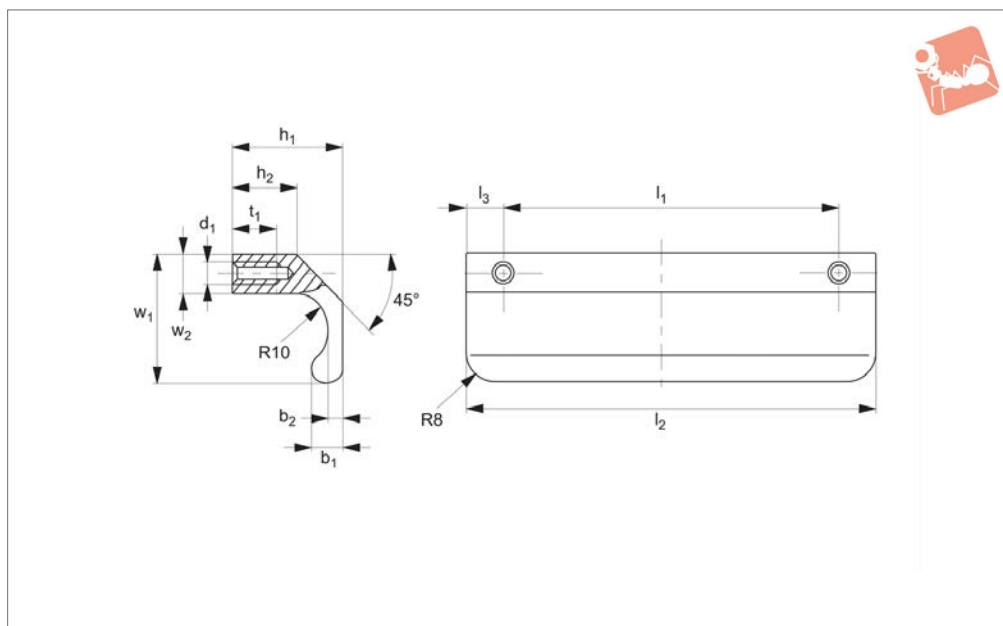

Material

Profiled stainless steel 316 (X2 CrNiMo 17 13 2, material no. 1.4404). Finish: blasted and electropolished with a semi-matt

finish.

Technical Notes

Minimum stress resistance 500N.

Any other handle lengths available on request.

Order No.	l_1	l_2	b_1	b_2	d_1	h_1	h_2	t_1	w_1	w_2
78850.W0060	60	80	8	4	M 6	30	20	12	35	10
78850.W0080	80	100	8	4	M 6	30	20	12	35	10
78850.W0100	100	120	8	4	M 6	30	20	12	35	10
78850.W0130	130	150	8	4	M 6	30	20	12	35	10

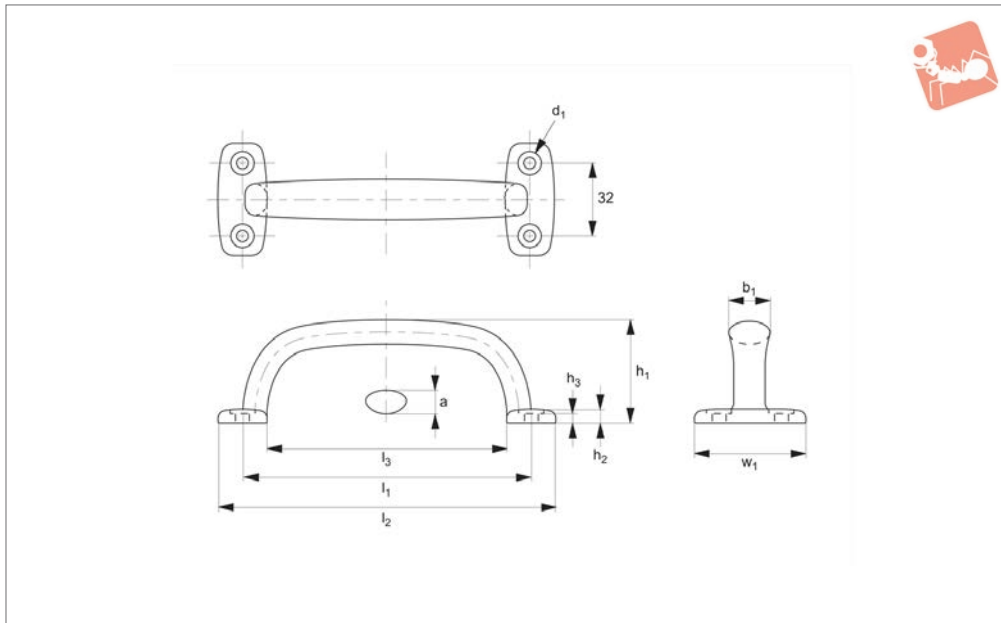

78890

PULL HANDLES

Material

AISI 316 stainless steel, mirror finish.

Technical Notes

Supplied with stainless steel screws. Ideal for harsh and high corrosive environments.

Order No.	l_1	l_2	l_3	a	b_1	d_1	h_1	h_2	h_3	w_1	Weight g
78890.W0064	64	82	46	8	16	4-Ø5, 4-Ø9,5	36.5	5.5	4.0	48	110
78890.W0096	96	114	78	9	16	4-Ø5, 4-Ø9,5	40.0	6.0	4.5	48	148
78890.W0128	128	150	106	10	18	4-Ø6, 4-Ø11,0	45.0	6.0	4.5	50	210
78890.W0160	160	180	140	10	20	4-Ø6, 4-Ø11,0	48.0	6.5	5.0	50	270



78900

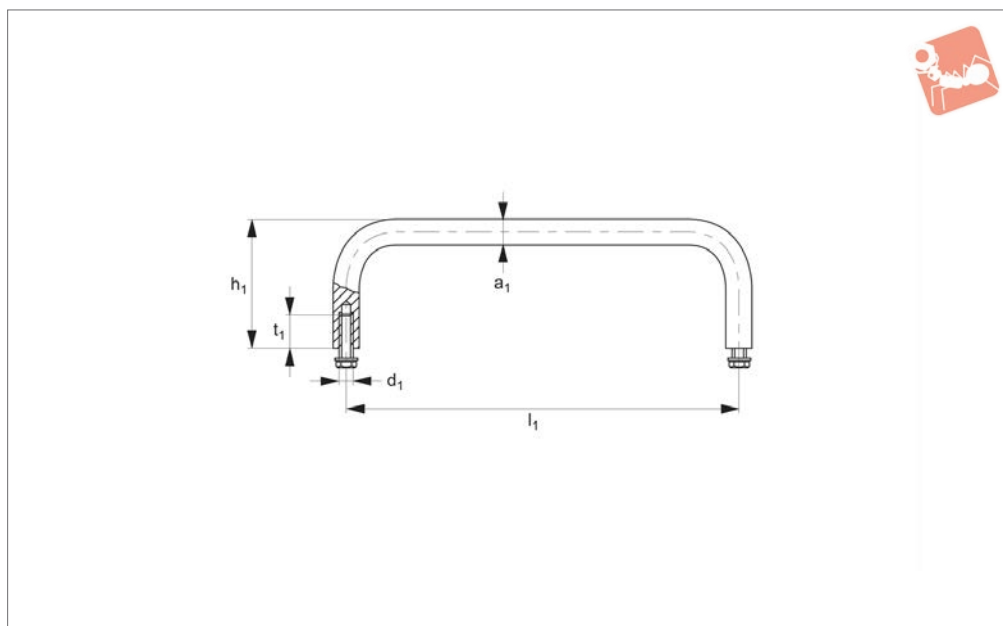

Material

Stainless steel rod X12 CrNiS 18 8, 1.4305 (AISI 303). Finish: matt gloss.

Tips

For medical technology, laboratory instruments with high chemical resistance.

Technical Notes

Minimum stress resistance 1000N.

Order No.	$\varnothing a_1$	l_1	d_1	h_1	t_1
78900.W0064	8	64	M 5x10	35	10
78900.W0088	8	88	M 5x10	35	10
78900.W0100	8	100	M 5x10	35	10
78900.W0120	10	120	M 5x10	40	10
78900.W0180	10	180	M 5x10	40	10
78900.W0250	10	250	M 5x10	40	10
78900.W0350	10	350	M 5x10	40	10
78900.W0400	15	150	M 6x16	55	12
78900.W0410	15	200	M 6x16	55	12
78900.W0420	15	250	M 6x16	55	12
78900.W0430	15	300	M 6x16	55	12
78900.W0440	15	350	M 6x16	55	12



Pull Handles - Oval Type

stainless steel

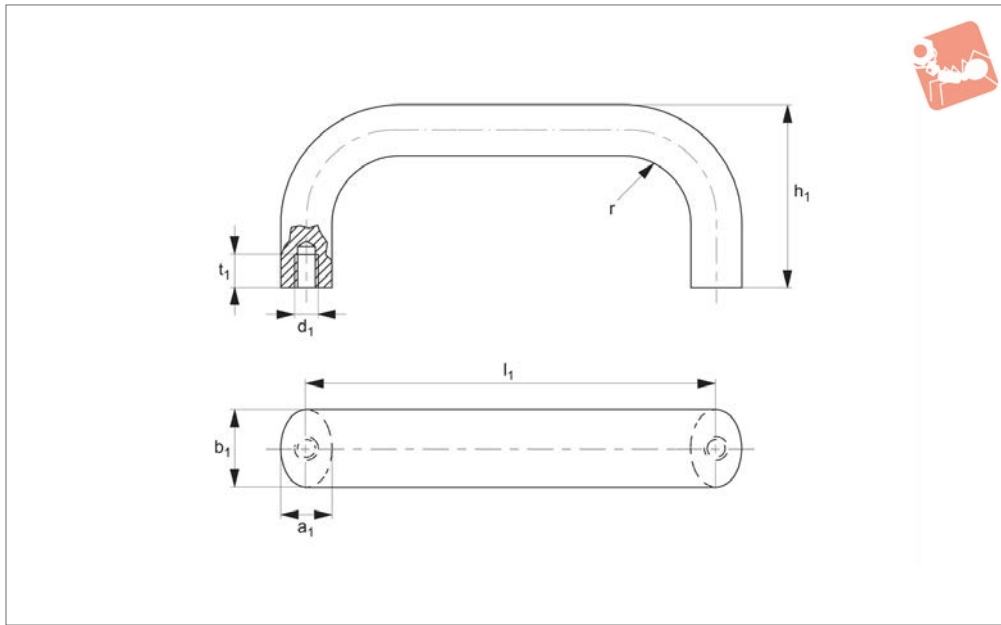

78910

PULL HANDLES

Material

Stainless steel 1.4301, dull blasted

Technical Notes

Ergonomic design offering high stability and smooth surfaces.

Order No.	l_1	a_1	b_1	d_1	h_1	R	t_1	Weight g
78910.W0510	112	13	20	M 6	49	13	10	270
78910.W0520	128	13	20	M 6	51	13	10	305
78910.W0530	160	13	20	M 6	51	13	10	366
78910.W0540	200	13	20	M 6	51	13	10	440
78910.W0550	250	13	20	M 6	51	13	10	517
78910.W0560	300	13	20	M 6	51	13	10	597
78910.W0580	400	13	20	M 6	51	13	10	737



78920

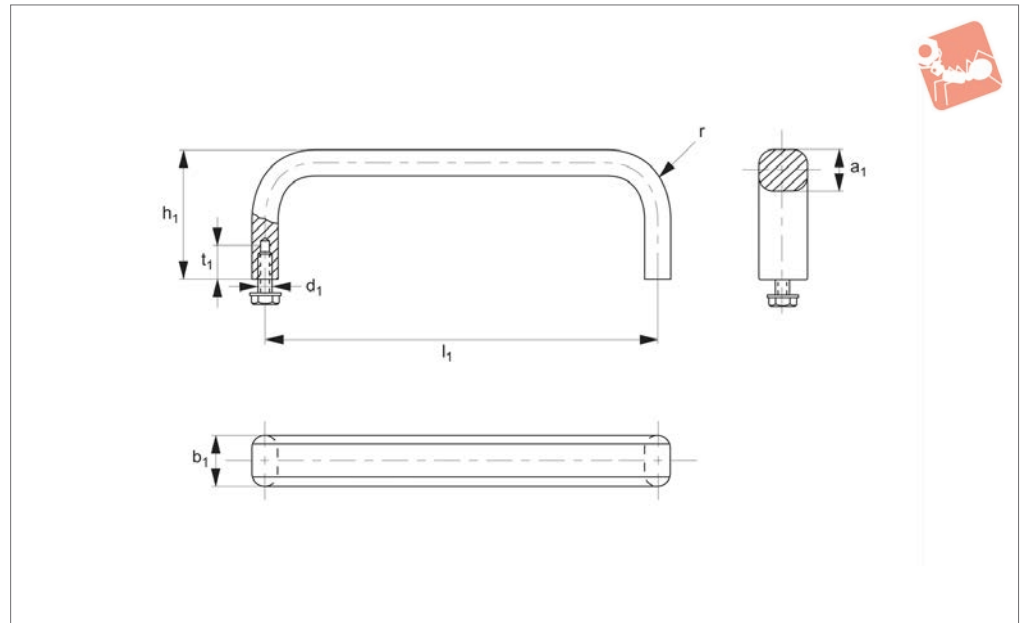

Material

Stainless steel X12 CrNiS 18 8, 1.4305 (AISI 303).

Finish: vibration ground with a semi-matte finish.

Technical Notes

Supplied with hex screws DIN 933 and suitable washer. Minimum stress resistance >1000N.

Tips

Attractively shaped handles for all applications, with high corrosive and chemical resistance. Other dimensions on request.

Order No.	Type	l_1	a_1	b_1	d_1	h_1	r	t_1
78920.W0010	Narrow	100	8	12.0	M_5x10	40	22	10
78920.W0012	Narrow	120	8	12.0	M_5x10	40	22	10
78920.W0015	Narrow	150	8	12.0	M_5x10	40	22	10
78920.W0018	Narrow	180	8	12.0	M_5x10	40	22	10
78920.W0025	Narrow	250	8	12.0	M_5x10	40	22	10
78920.W0035	Narrow	350	8	12.0	M_5x10	40	22	10
78920.W0110	Wide	100	10	19.5	M_6x12	45	24	12
78920.W0112	Wide	120	10	19.5	M_6x12	45	24	12
78920.W0115	Wide	150	10	19.5	M_6x12	45	24	12
78920.W0118	Wide	180	10	19.5	M_6x12	45	24	12
78920.W0125	Wide	250	10	19.5	M_6x12	45	24	12
78920.W0135	Wide	350	10	19.5	M_6x12	45	24	12

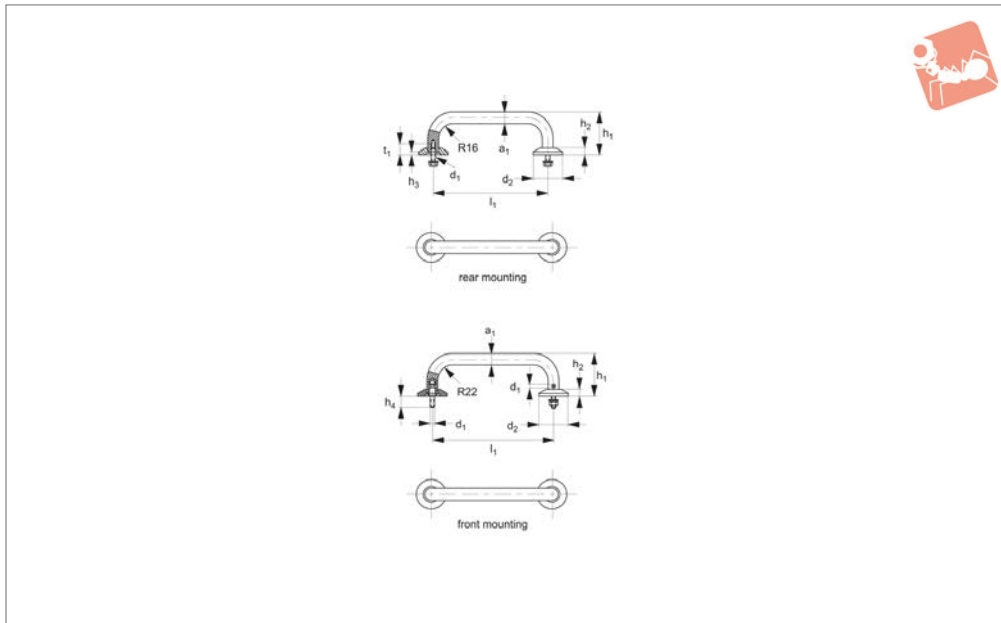

78940

PULL HANDLES

Material

Round stainless steel X12 CrNiS 18 8, material no. 1.4305. Finish: ground and brushed for a matt finish.

DIN 933 and washers.

Rear mounting: supplied with mounting adapter and suitable nuts and washer. Minimum stress resistance >1000N.

required. Other dimensions on request.

Technical Notes

Front mounting: supplied with hex screws

Tips

Where maximum load-bearing capacity is

Order No.	Type	l_1	a_1	d_1	d_2	h_1	h_2	h_3	h_4	t_1
78940.W0015	Rear Mounting	150	15	M 6 x 20	38	58	9	4	-	16
78940.W0020	Rear Mounting	200	15	M 6 x 20	38	58	9	4	-	16
78940.W0025	Rear Mounting	250	15	M 6 x 20	38	58	9	4	-	16
78940.W0120	Front Mounting	200	20	M 8	50	75	12	5	16	21
78940.W0125	Front Mounting	250	20	M 8	50	75	12	5	16	21
78940.W0130	Front Mounting	300	20	M 8	50	75	12	5	16	21
78940.W0220	Rear Mounting	200	20	M 8 x 25	50	75	12	5	-	-
78940.W0225	Rear Mounting	250	20	M 8 x 25	50	75	12	5	-	-
78940.W0230	Rear Mounting	300	20	M 8 x 25	50	75	12	5	-	-



78950

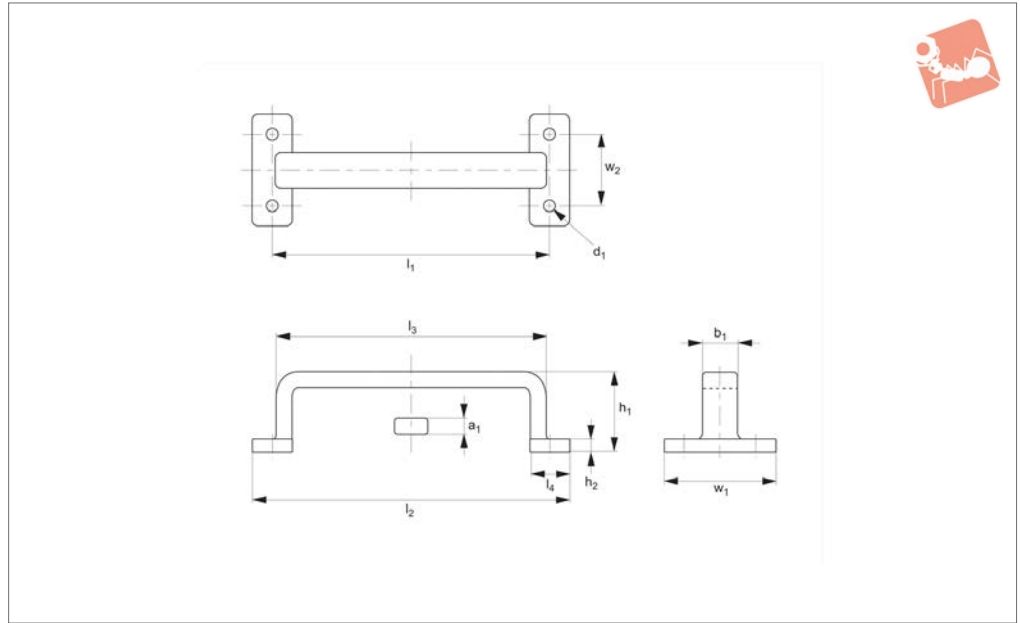

PULL HANDLES

Material

AISI 316 stainless steel, mirror finish.

Technical Notes

Supplied with stainless steel screws.

Important Notes

Ideal for harsh and high corrosive environments. Higher profile allows for easy gripping with gloved hand.

Order No.	l_1	l_2	l_3	l_4	a_1	b_1	h_1	h_2	w_1	w_2	Weight g
78950.W0200	175	200	170	25	10	22	50	8	70	45	586
78950.W0280	253	280	250	27	12	26	62	10	80	55	1088



Pull Handles - Collapsible

stainless steel

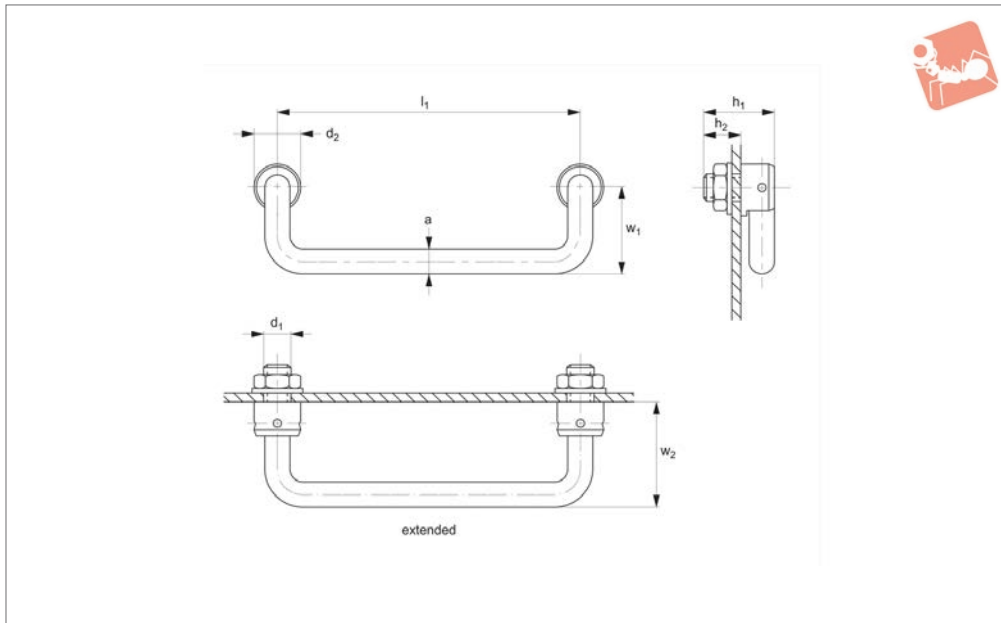

78970

PULL HANDLES

Material

All components made of round bar stainless steel, material no. 1.4305. Finish: vibration ground to a semi-matt finish.

Technical Notes

Spring-arrest in both retracted and extended positions. One piece pivot bushing. Minimum stress resistance 500N.

Tips

Supplied complete with nuts and washers.

Order No.	l_1	a	d_1	d_2	h_1	h_2	w_1	w_2
78970.W0100	100	10	M10x1	18	28	14	34	43
78970.W0120	120	10	M10x1	18	28	14	34	43
78970.W0180	180	10	M10x1	18	28	14	34	43



79750

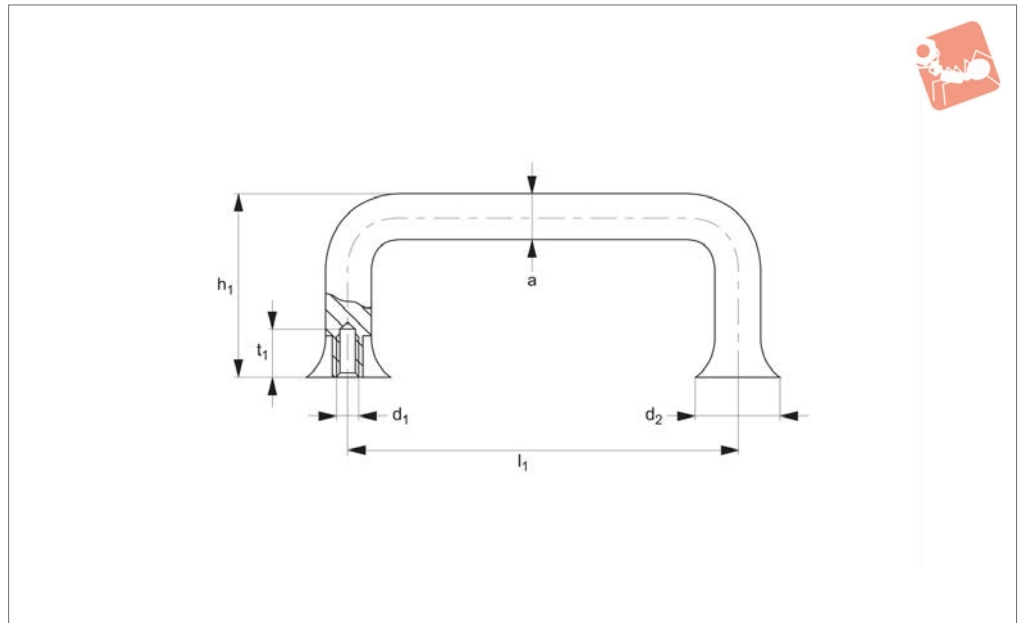

PULL HANDLES

Material

Round bar stainless steel 1.4305 (AISI 303), vibration ground, semi-matte finish. Supplied with stainless steel hex screws, DIN933 and suitable nuts and washers.

Technical Notes

Minimum stress resistance >1000N.

Tips

The trumpet like design of the handle base

makes them easy to clean thoroughly. The handles are therefore particularly suitable for hygienic areas.

Order No.	l_1	a	d_1	d_2	h_1	t_1
79750.W0119	120	10	M 5	20	45	10
79750.W0120	120	15	M 6	30	60	12
79750.W0140	140	15	M 6	30	60	12
79750.W0100	100	10	M 5	20	45	10
79750.W0200	200	15	M 6	30	60	12



Pull Handles - 3A Standard

hygienic line, stainless steel

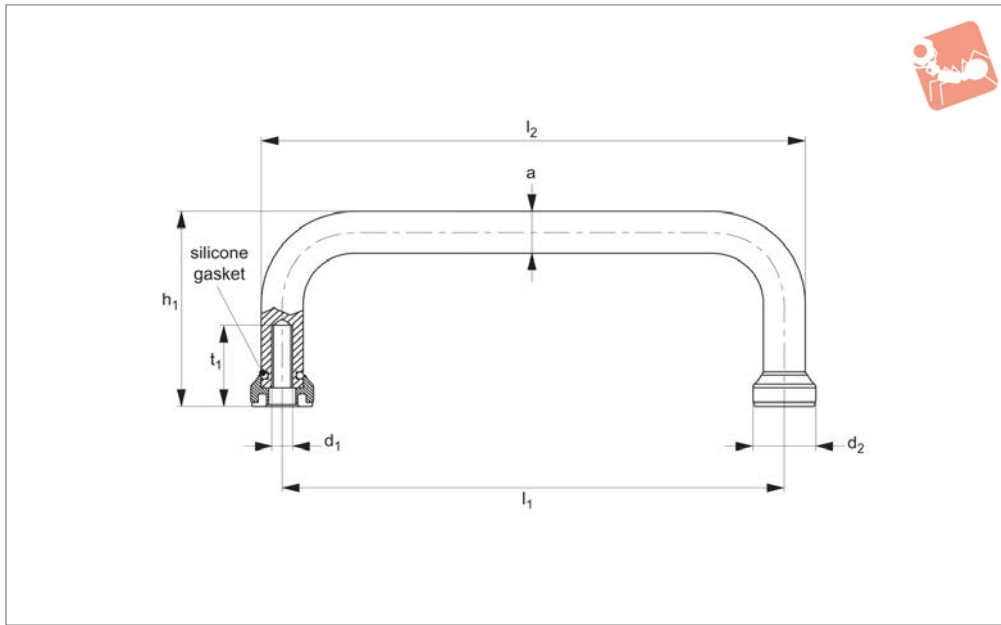

79760

PULL HANDLES

Material

Round bar stainless steel AISI304
Blue gasket: silicone

Tips

Made to the high „3A“ standard.

This ensures it meets the high standards required for use in food, beverage, pharmaceutical and medical applications. Hygienically designed for effective and easy cleaning, corrosion resistant, non-

toxic. Design precludes contamination by dirt, food particles and organic matter.

Order No.	l_1	l_2	a	d_1	d_2	h_1	t_1
79760.W0088	88	98	10	M5	15	46	10
79760.W0100	100	110	10	M5	15	46	10
79760.W0120	120	130	10	M5	15	46	10
79760.W0180	180	190	10	M5	15	46	10



78190

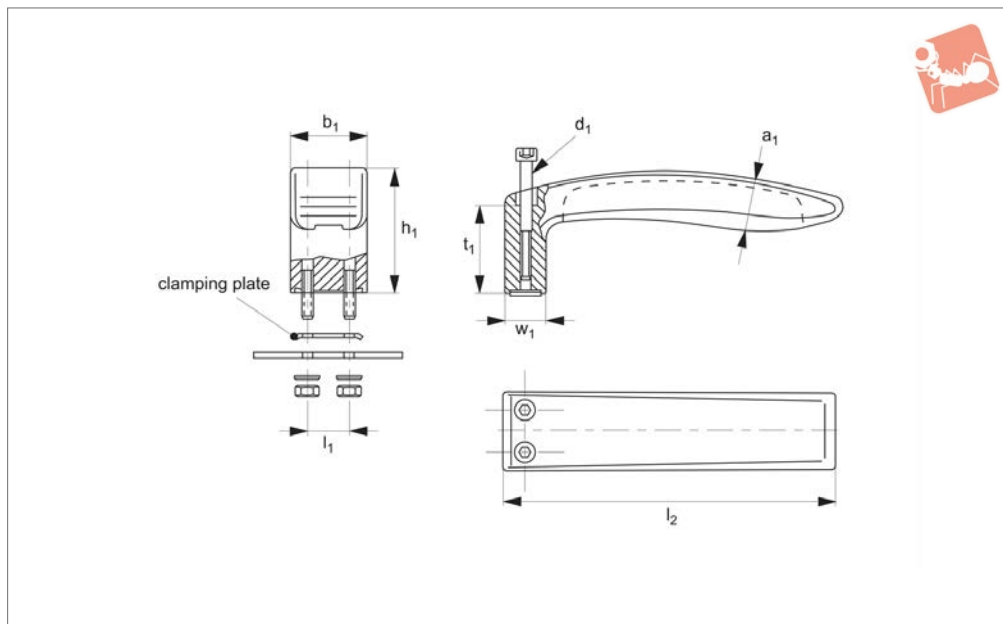

Material

Thermoplastic PA 6, glass ball reinforced, matt black.

Technical Notes

Ideal for applications where one-sided fastening required. Minimum stress resi-

stance 800N per handle.

Order No.	l_1	l_2	a_1	b_1	d_1	h_1	t_1	w_1
78190.W0017	17	128	20	30	M 5x45	48	33	18
78190.W0020	20	154	24	36	M 6x55	58	40	22



Pull Handles

plastic, with coloured caps

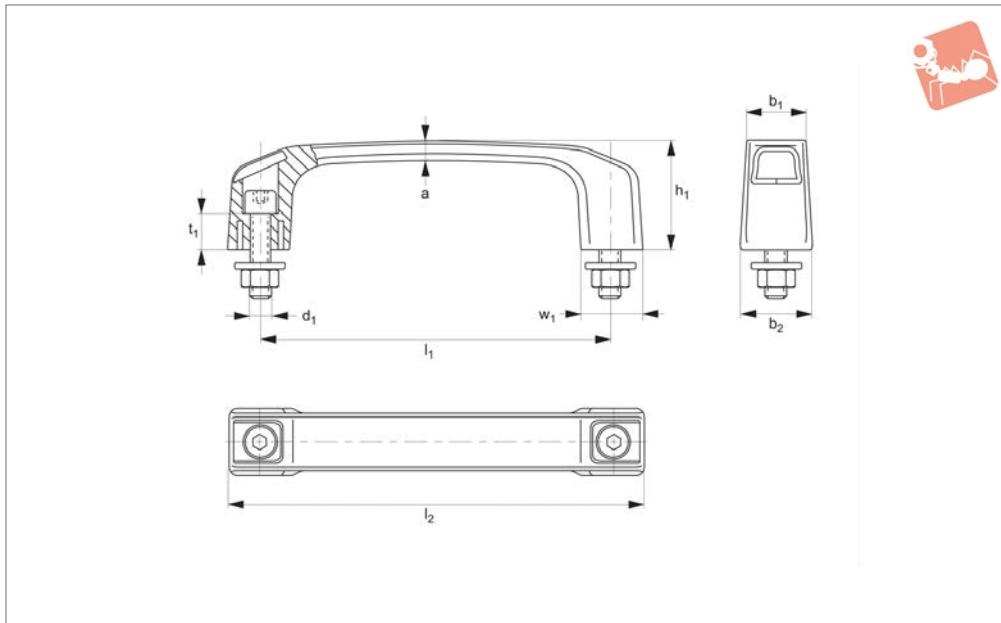

79100

PULL HANDLES

Material

Handle: thermoplastic PA 6 glass-ball reinforced. Matt black with attractive fine-grain structure. Blanking caps: in the same surface structure available in black, red, green, blue and yellow.

Technical Notes

Includes electrogalvanized socket-head cap bolts DIN 912, nuts DIN 934 and washers DIN 125.
Minimum stress resistance 1000N.

Tips

Red - similar to RAL 3020
Green - similar to RAL 6024
Blue - similar to RAL 5017
Yellow - similar to RAL 1023

Order No.	Cap colour	l_1	l_2	a	b_1	b_2	d_1	h_1	t_1	w_1
79100.W0120-9	Black	120	141	7	21	24	M_6x25	39	13	21
79100.W0140-9	Black	140	164	8	24	28	M_8x30	45	15	24
79100.W0120-3	Red	120	141	7	21	24	M_6x25	39	13	21
79100.W0140-3	Red	140	164	8	24	28	M_8x30	45	15	24
79100.W0120-6	Green	120	141	7	21	24	M_6x25	39	13	21
79100.W0140-6	Green	140	164	8	24	28	M_8x30	45	15	24
79100.W0120-5	Blue	120	141	7	21	24	M_6x25	39	13	21
79100.W0140-5	Blue	140	164	8	24	28	M_8x30	45	15	24
79100.W0120-1	Yellow	120	141	7	21	24	M_6x25	39	13	21
79100.W0140-1	Yellow	140	164	8	24	28	M_8x30	45	15	24
79100.W0120-0	W/o Caps & Screws	120	141	7	21	24	M_6x25	39	13	21
79100.W0140-0	W/o Caps & Screws	140	164	8	24	28	M_8x30	45	15	24



79120

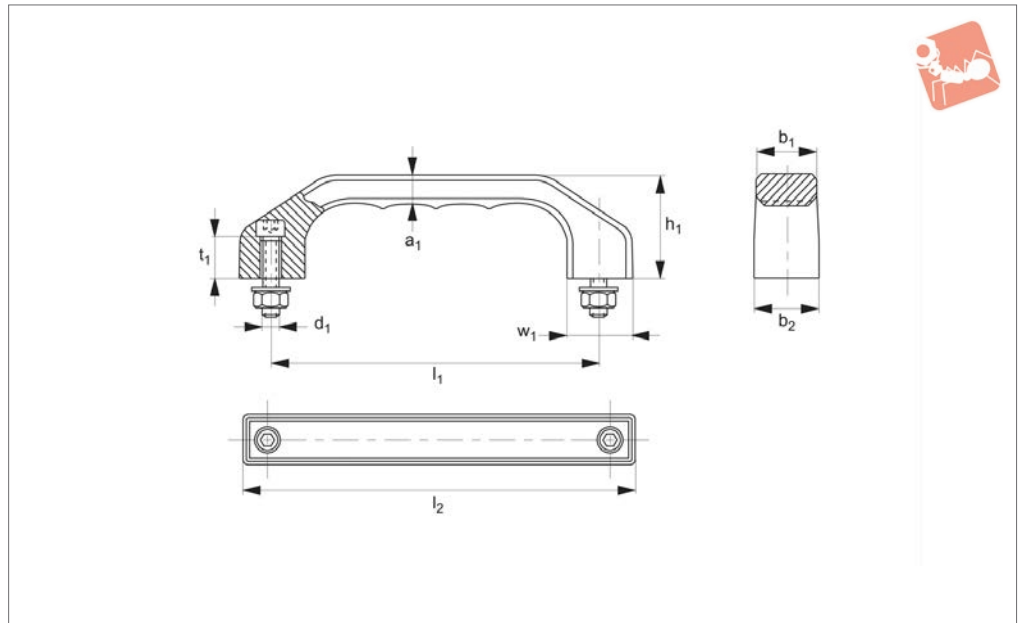

Material

Solid thermoplastic PA 6, glass ball reinforced. Matt black or orange with attractive, fine grain structure.

Technical Notes

Including hex screws DIN912 with suitable

nuts and washer. Solid plastic. Modern industrial design for the highest demands. Extremely resistant to torsion and easy to grip. Minimum stress resistance >1000N. And scope of supply.

Including black galvanised cheese head screws (chromium VI free) with hexagon sockets DIN 912 and galvanised nuts DIN 934 with washers DIN 125.

Order No.	Finish	l_1	l_2	a_1	b_1	b_2	d_1	h_1	t_1	w_1
79120.W0100-8	Black	100	122	8.5	17.0	19	M 5x22	33	13	20
79120.W0120-8	Black	120	146	10.5	20.5	24	M 6x25	39	15	24
79120.W0140-8	Black	140	170	12.0	24.0	27	M 8x30	45	16	28
79120.W0160-8	Black	160	194	13.5	27.5	31	M 8x35	52	20	32
79120.W0180-8	Black	180	218	15.5	31.0	35	M10x40	58	20	36
79120.W0100-0	Orange	100	122	8.5	17.0	19	M 5x22	33	13	20
79120.W0120-0	Orange	120	146	10.5	20.5	24	M 6 x25	39	15	24
79120.W0140-0	Orange	140	170	12.0	24.0	27	M 8 x30	45	16	28
79120.W0160-0	Orange	160	194	13.5	27.5	31	M 8x35	52	20	32
79120.W0180-0	Orange	180	218	15.5	31.0	35	M10x40	58	20	36



Plastic Pull Handles

through hole or threaded bush

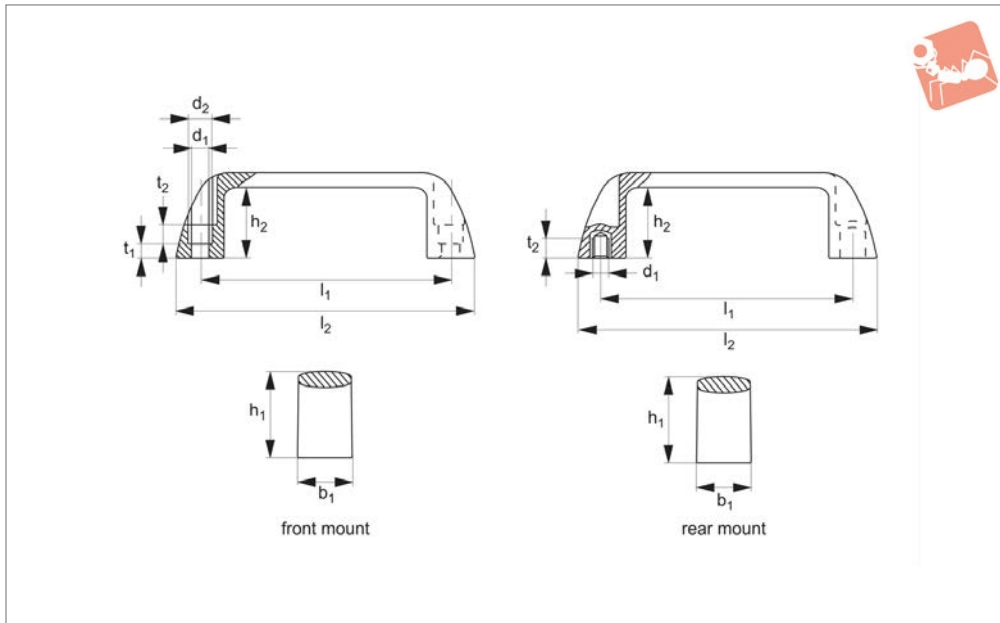

79150

PULL HANDLES

Material

Thermoplastic, black, matt, glass fibre reinforced.

Threaded bush: brass.

Technical Notes

Other colours on request: red, orange,

white & grey - subject to minimum quantity.

Order No.	Type	l_1	l_2	b_1	d_2	h_1	h_2	t_1	t_2	$\emptyset d_1$	Weight g
79150.W0010	Front Mount	93.5	112	21	Ø10,5	36	30	6	7	6.5	26
79150.W0011	Front Mount	117.0	139	26	Ø10,5	41	34	6	9	6.5	41
79150.W0012	Front Mount	117.0	139	26	Ø13,0	41	34	6	9	8.5	40
79150.W0013	Front Mount	132.0	156	27	Ø10,5	45	37	9	7	6.5	56
79150.W0014	Front Mount	132.0	156	27	Ø13,0	45	37	7	9	8.5	54
79150.W0018	Front Mount	179.0	204	28	Ø13,0	50	42	8	9	8.5	72
79150.W0509	Rear Mount	93.5	112	21	-	36	30	-	9	M 5	33
79150.W0510	Rear Mount	93.5	112	21	-	36	30	-	9	M 6	33
79150.W0511	Rear Mount	117.0	139	26	-	41	34	-	9	M 6	47
79150.W0512	Rear Mount	117.0	139	26	-	41	34	-	9	M 8	49
79150.W0513	Rear Mount	132.0	156	27	-	45	37	-	9	M 6	62
79150.W0514	Rear Mount	132.0	156	27	-	45	37	-	9	M 8	64
79150.W0518	Rear Mount	179.0	204	28	-	50	42	-	9	M 8	82



PULL HANDLES



79180

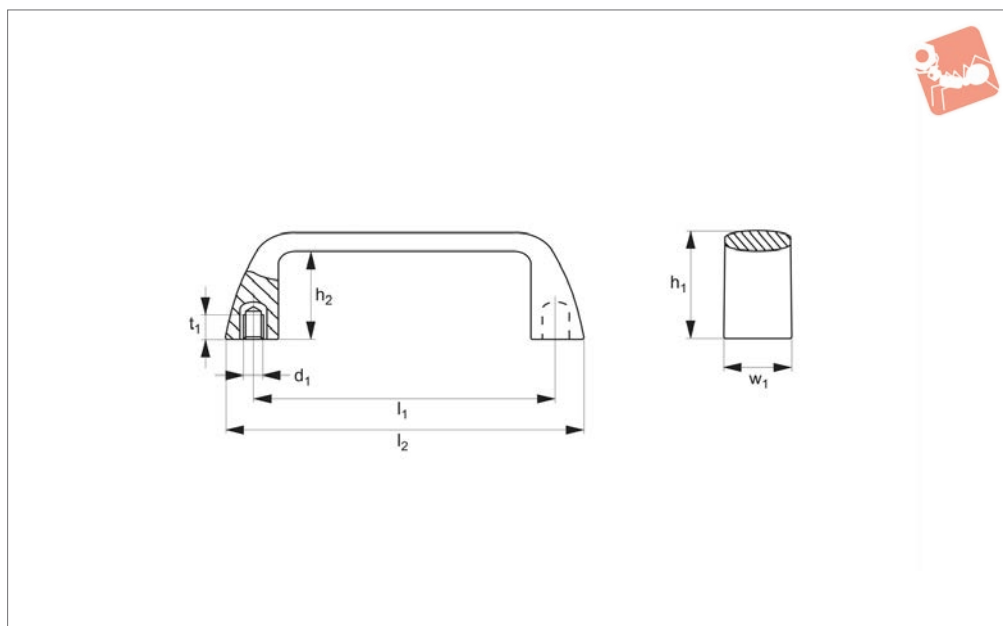

Material

Thermoplastic, black, matt. Glass fibre reinforced.

Brass insert with tapped blind hole.

Technical Notes

Other colours on request:- red, orange,

white & grey - subject to minimum quantity.

Order No.	l_1	l_2	d_1	h_1	h_2	t_1	w_1	Weight g
79180.W0009	105	121	M 5	37	29	9	26	46
79180.W0010	105	121	M 6	37	29	9	26	48
79180.W0011	110	133	M 5	40	32	9	26	58
79180.W0012	110	133	M 6	40	32	9	26	60
79180.W0016	117	133	M 5	40	32	9	26	57
79180.W0017	117	133	M 6	40	32	9	26	59
79180.W0018	117	133	M 8	40	32	9	26	61



Pull Handles - Heavy Duty aluminium

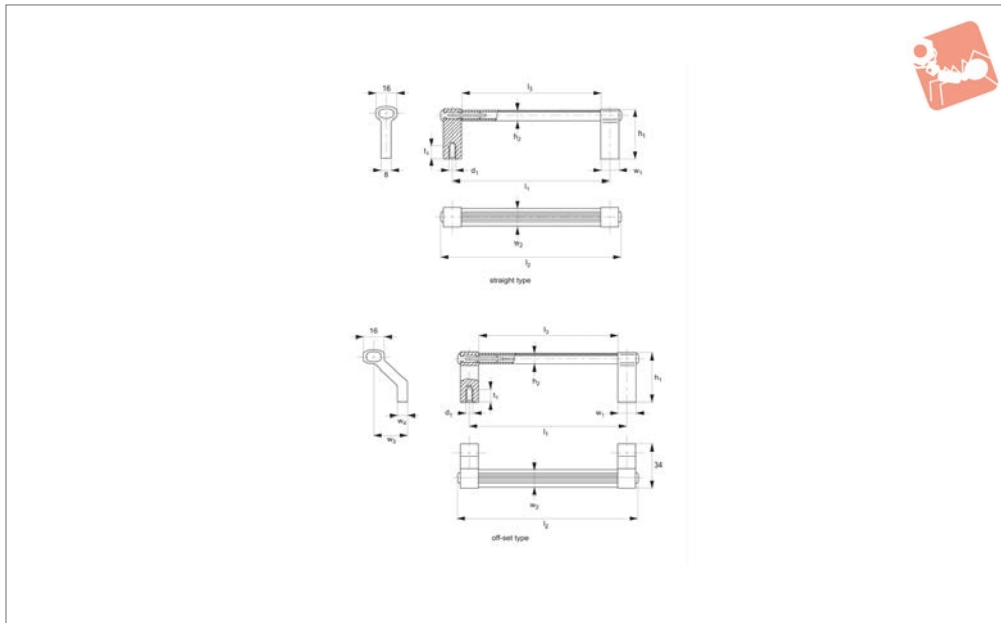

79200

PULL HANDLES

Material

Handle shank and grip: profiled aluminium Al Mg Si 0,5. Connecting moulded components made of black polyamide with stainless steel pin.
Handle shank vibration ground and matte

finished. Grip

Technical Notes

Minimum stress resistance 1000N. Handle with tangent bent aluminium shanks, completely assembled.

Tips

For 19" front panels and appliances. Provides high stability under load. Black grips available on request.

Order No.	Colour	Type	l_1	l_2	l_3	d_1	h_1	h_2	t_1	w_1	w_2	w_3	w_4
79200.W0055-0	Natural	Straight	55	73	41	M 5	40	9	10	14	14	-	-
79200.W0055-1	Black	Straight	55	73	41	M 5	40	9	10	14	14	-	-
79200.W0069-0	Natural	Straight	69	87	55	M 5	40	9	10	14	14	-	-
79200.W0069-1	Black	Straight	69	87	55	M 5	40	9	10	14	14	-	-
79200.W0088-0	Natural	Straight	88	106	74	M 5	40	9	10	14	14	-	-
79200.W0088-1	Black	Straight	88	106	74	M 5	40	9	10	14	14	-	-
79200.W0100-0	Natural	Straight	100	118	86	M 5	40	9	10	14	14	-	-
79200.W0100-1	Black	Straight	100	118	86	M 5	40	9	10	14	14	-	-
79200.W0114-0	Natural	Straight	114	132	100	M 5	40	9	10	14	14	-	-
79200.W0114-1	Black	Straight	114	132	100	M 5	40	9	10	14	14	-	-
79200.W0120-0	Natural	Straight	120	138	104	M 5	40	9	10	14	14	-	-
79200.W0120-1	Black	Straight	120	138	104	M 5	40	9	10	14	14	-	-
79200.W0180-0	Natural	Straight	180	198	166	M 5	40	9	10	14	14	-	-
79200.W0180-1	Black	Straight	180	198	166	M 5	40	9	10	14	14	-	-
79200.W0555-0	Natural	Offset	55	73	41	M 5	40	9	10	14	14	22	8
79200.W0555-1	Black	Offset	55	73	41	M 5	40	9	10	14	14	22	8
79200.W0569-0	Natural	Offset	69	87	55	M 5	40	9	10	14	14	22	8
79200.W0569-1	Black	Offset	69	87	55	M 5	40	9	10	14	14	22	8
79200.W0588-0	Natural	Offset	88	106	74	M 5	40	9	10	14	14	22	8
79200.W0588-1	Black	Offset	88	106	74	M 5	40	9	10	14	14	22	8
79200.W0600-0	Natural	Offset	100	118	86	M 5	40	9	10	14	14	22	8
79200.W0600-1	Black	Offset	100	118	86	M 5	40	9	10	14	14	22	8
79200.W0614-0	Natural	Offset	114	132	100	M 5	40	9	10	14	14	22	8
79200.W0614-1	Black	Offset	114	132	100	M 5	40	9	10	14	14	22	8
79200.W0620-0	Natural	Offset	120	138	104	M 5	40	9	10	14	14	22	8
79200.W0620-1	Black	Offset	120	138	104	M 5	40	9	10	14	14	22	8
79200.W0680-0	Natural	Offset	180	198	166	M 5	40	9	10	14	14	22	8
79200.W0680-1	Black	Offset	180	198	166	M 5	40	9	10	14	14	22	8



79210

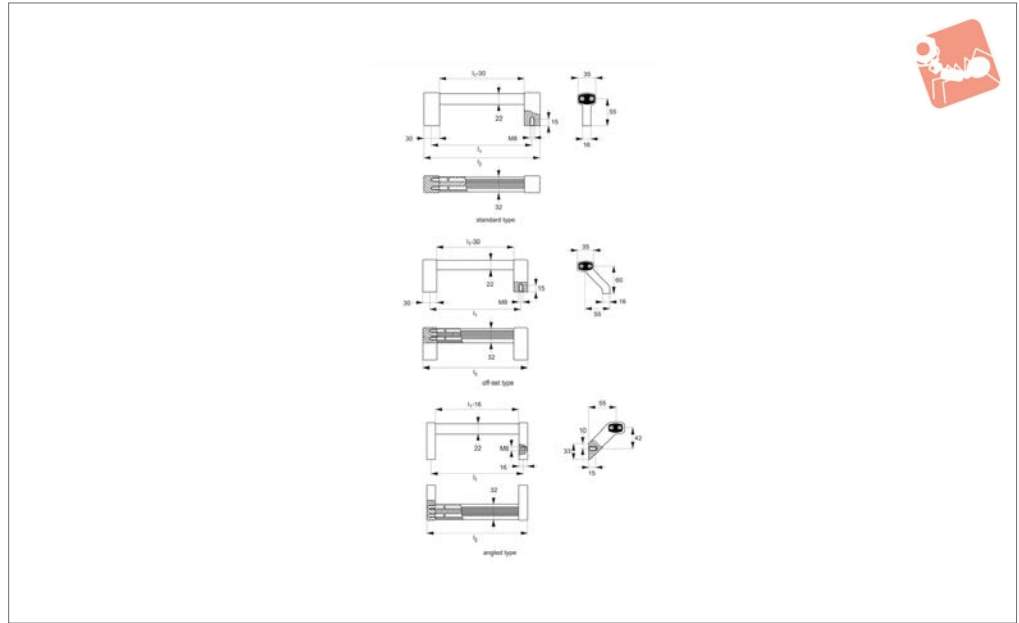

Material

Handle shank and grip: aluminium section Al Mg Si 0,5. Glass bead blasted and semi-glossed, anodised.

Technical Notes

Supplied with hex screws DIN 933, M8x16

and suitable washers. Minimum stress resistance >1000N.

Tips

Black grips available on request. Any desired handle lengths and surfaces available on request.

Order No.	Type	Grip finish	Shank finish	l_1	l_2
79210.W0020-0	Straight	Natural	Natural	200	230
79210.W0020-1	Straight	Natural	Black	200	230
79210.W0025-0	Straight	Natural	Natural	250	280
79210.W0025-1	Straight	Natural	Black	250	280
79210.W0030-0	Straight	Natural	Natural	300	330
79210.W0030-1	Straight	Natural	Black	300	330
79210.W0035-0	Straight	Natural	Natural	350	380
79210.W0035-1	Straight	Natural	Black	350	380
79210.W0040-0	Straight	Natural	Natural	400	430
79210.W0040-1	Straight	Natural	Black	400	430
79210.W0050-0	Straight	Natural	Natural	500	530
79210.W0050-1	Straight	Natural	Black	500	530
79210.W0060-0	Straight	Natural	Natural	600	630
79210.W0060-1	Straight	Natural	Black	600	630
79210.W0220-0	Offset	Natural	Natural	200	230
79210.W0220-1	Offset	Natural	Black	200	230
79210.W0225-0	Offset	Natural	Natural	250	280
79210.W0225-1	Offset	Natural	Black	250	280
79210.W0230-0	Offset	Natural	Natural	300	330
79210.W0230-1	Offset	Natural	Black	300	330
79210.W0235-0	Offset	Natural	Natural	350	380
79210.W0235-1	Offset	Natural	Black	350	380
79210.W0240-0	Offset	Natural	Natural	400	430
79210.W0240-1	Offset	Natural	Black	400	430
79210.W0250-0	Offset	Natural	Natural	500	530
79210.W0250-1	Offset	Natural	Black	500	530
79210.W0260-0	Offset	Natural	Natural	600	630
79210.W0260-1	Offset	Natural	Black	600	630
79210.W0420-0	Angled	Natural	Natural	200	230
79210.W0420-1	Angled	Natural	Black	200	230
79210.W0425-0	Angled	Natural	Natural	250	280
79210.W0425-1	Angled	Natural	Black	250	280



Pull Handles - Heavy Duty aluminium



Order No.	Type	Grip finish	Shank finish	l ₁	l ₂
79210.W0430-0	Angled	Natural	Natural	300	330
79210.W0430-1	Angled	Natural	Black	300	330
79210.W0435-0	Angled	Natural	Natural	350	380
79210.W0435-1	Angled	Natural	Black	350	380
79210.W0440-0	Angled	Natural	Natural	400	430
79210.W0440-1	Angled	Natural	Black	400	430
79210.W0450-0	Angled	Natural	Natural	500	530
79210.W0450-1	Angled	Natural	Black	500	530
79210.W0460-0	Angled	Natural	Natural	600	630
79210.W0460-1	Angled	Natural	Black	600	630



79240

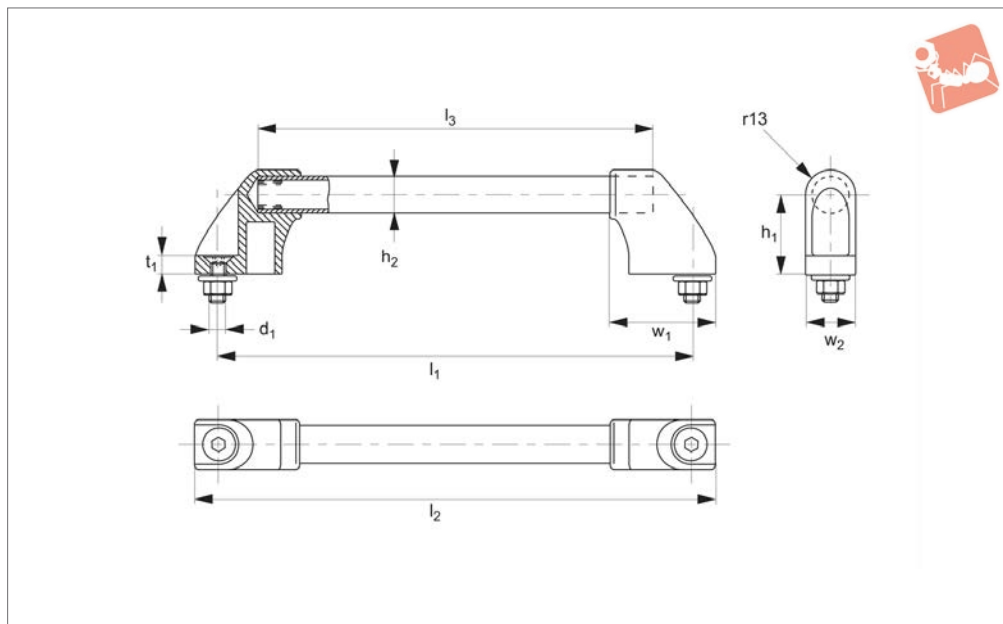

Material

Handle shank: polyamide, PA 6 glass ball reinforced, black, semi-matt, with fine structure.

Connecting tube: aluminium ALMgSi 0.5, ground and anodized in natural colour or

with grooved plastic cover.

Technical Notes

Supplied with hex screws DIN 7991 M8 x 20, and suitable nuts and washers.

Minimum stress resistance 500N.

Tips

The handle shank is fitted with 4 clamping pins, when the connection tube is pressed in the pins form around the tube and provide a firm hold.

Order No.	Finish	l_1	l_2	l_3	d_1	h_1	h_2	t_1	w_1	w_2
79240.W0010	Natural	180	204	140	M 8 x 20	42	Ø20 x 2	10	55	26
79240.W0020	Natural	200	224	160	M 8 x 20	42	Ø20 x 2	10	55	26
79240.W0025	Natural	250	274	210	M 8 x 20	42	Ø20 x 2	10	55	26
79240.W0030	Natural	300	324	260	M 8 x 20	42	Ø20 x 2	10	55	26
79240.W0035	Natural	350	374	310	M 8 x 20	42	Ø20 x 2	10	55	26
79240.W0040	Natural	400	424	360	M 8 x 20	42	Ø20 x 2	10	55	26
79240.W0050	Natural	500	524	460	M 8 x 20	42	Ø20 x 2	10	55	26
79240.W0060	Natural	600	624	560	M 8 x 20	42	Ø20 x 2	10	55	26
79240.W0110	Plastic	180	204	140	M 8 x 20	42	Ø20 x 2	10	55	26
79240.W0120	Plastic	200	224	160	M 8 x 20	42	Ø20 x 2	10	55	26
79240.W0125	Plastic	250	274	210	M 8 x 20	42	Ø20 x 2	10	55	26
79240.W0130	Plastic	300	324	260	M 8 x 20	42	Ø20 x 2	10	55	26
79240.W0135	Plastic	350	374	310	M 8 x 20	42	Ø20 x 2	10	55	26
79240.W0140	Plastic	400	424	360	M 8 x 20	42	Ø20 x 2	10	55	26
79240.W0150	Plastic	500	524	460	M 8 x 20	42	Ø20 x 2	10	55	26
79240.W0160	Plastic	600	624	560	M 8 x 20	42	Ø20 x 2	10	55	26

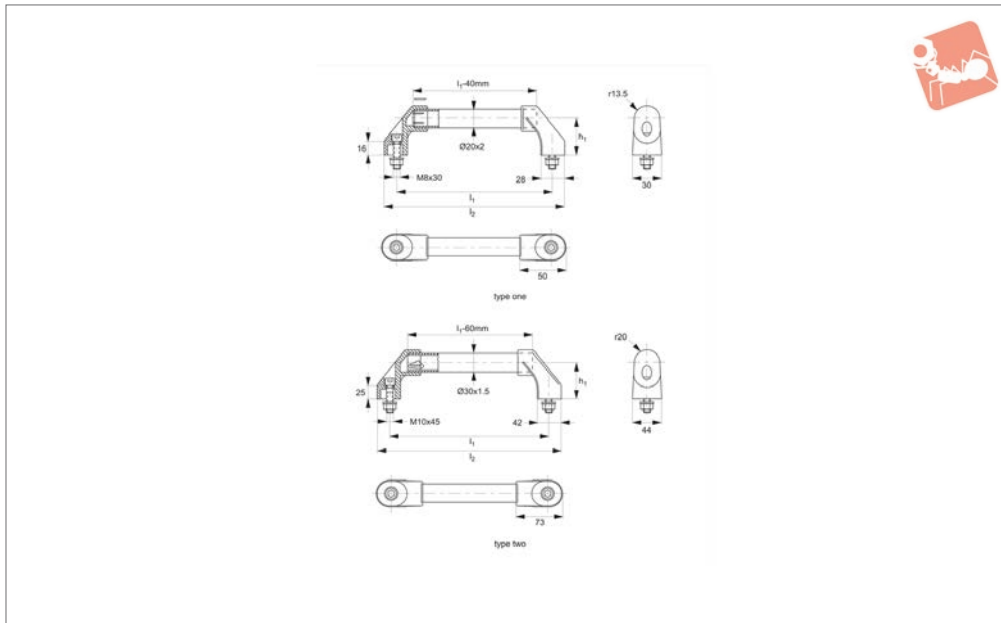

79250

PULL HANDLES

Material

Handle shank: polyamide, PA 6 glass ball reinforced, black, semi-matt with fine structure.
 Connection tube: aluminium Al Mg Si 0,5.
 Surface finishes: ground and anodised in natural colour. Grooved plastic cover,

black. Powder coated, black.

Technical Notes

Type one: supplied with hex screws DIN 912 M8x30, and suitable nuts and washers.
 Type two: supplied with hex screws DIN912 M10x45 and suitable nuts and washers.

Minimum stress resistance 1000N.

Tips

The handle shank is fitted with 4 clamping pins, when the connection tube is pressed in the pins form around the tube and provide a firm hold.

Order No.	Type	Finish	l ₁	l ₂	h ₁ height to centre
79250.W0018	One	Natural	180	210	42
79250.W0020	One	Natural	200	230	42
79250.W0025	One	Natural	250	280	42
79250.W0030	One	Natural	300	330	42
79250.W0035	One	Natural	350	380	42
79250.W0040	One	Natural	400	430	42
79250.W0050	One	Natural	500	530	42
79250.W0060	One	Natural	600	630	42
79250.W0118	One	Plastic Coat	180	210	42
79250.W0120	One	Plastic Coat	200	230	42
79250.W0125	One	Plastic Coat	250	280	42
79250.W0130	One	Plastic Coat	300	330	42
79250.W0135	One	Plastic Coat	350	380	42
79250.W0140	One	Plastic Coat	400	430	42
79250.W0150	One	Plastic Coat	500	530	42
79250.W0160	One	Plastic Coat	600	630	42
79250.W0218	One	Powder Coat	180	210	42
79250.W0220	One	Powder Coat	200	230	42
79250.W0225	One	Powder Coat	250	280	42
79250.W0230	One	Powder Coat	300	330	42
79250.W0235	One	Powder Coat	350	380	42
79250.W0240	One	Powder Coat	400	430	42
79250.W0250	One	Powder Coat	500	530	42
79250.W0260	One	Powder Coat	600	630	42
79250.W0525	Two	Natural	250	294	60
79250.W0530	Two	Natural	300	344	60
79250.W0535	Two	Natural	350	394	60
79250.W0540	Two	Natural	400	444	60
79250.W0550	Two	Natural	500	544	60
79250.W0560	Two	Natural	600	644	60
79250.W0625	Two	Plastic Coat	250	294	60



Order No.	Type	Finish	l_1	l_2	h_1 height to centre
79250.W0630	Two	Plastic Coat	300	344	60
79250.W0635	Two	Plastic Coat	350	394	60
79250.W0640	Two	Plastic Coat	400	444	60
79250.W0650	Two	Plastic Coat	500	544	60
79250.W0660	Two	Plastic Coat	600	644	60
79250.W0725	Two	Powder Coat	250	294	60
79250.W0730	Two	Powder Coat	300	344	60
79250.W0735	Two	Powder Coat	350	394	60
79250.W0740	Two	Powder Coat	400	444	60
79250.W0750	Two	Powder Coat	500	544	60
79250.W0760	Two	Powder Coat	600	644	60



Pull Handle System aluminium



Pull Handles

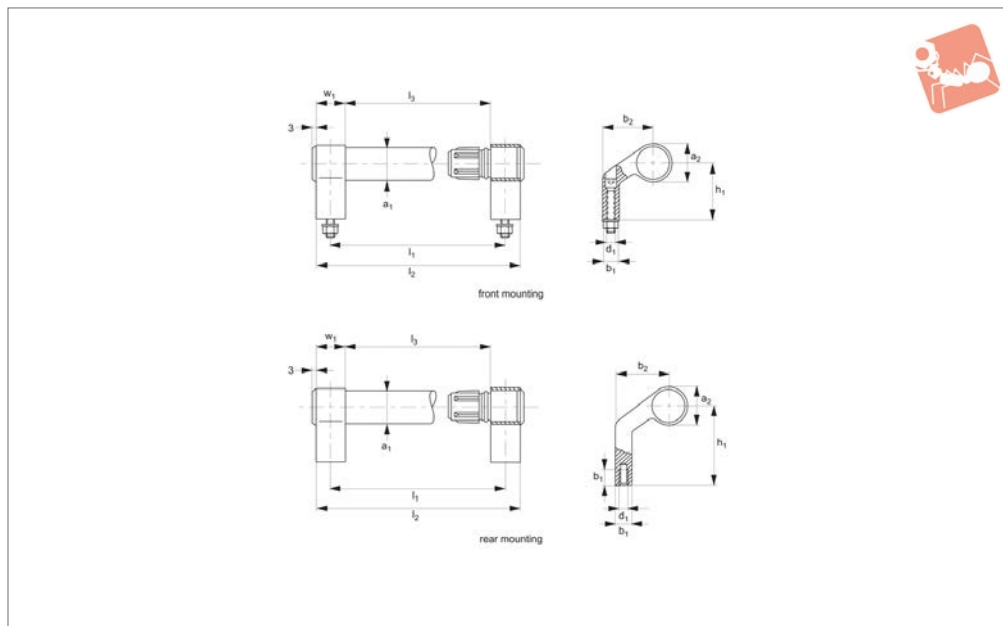

79270

PULL HANDLES

Material

Handle shank: extruded aluminium Al Mg Si 0,5. Anodised, matt black. Insert of black reinforced polyamide (PA6).
Connecting tube: aluminium Al Mg Si 0,5

Ø30 x 1,5mm. Precision ground and anodised.

Technical Notes

Minimum stress resistance >1000N. Wide

shank includes stainless steel cylinder head socket screws M6x45 DIN 912, nuts DIN 934 and washers DIN 125.

Order No.	Mounting type	Shank finish	Shank type	Tube finish	l_1	l_2	l_3
79270.W0020-1	Rear	Black	Narrow	Natural	200	225	175
79270.W0025-1	Rear	Black	Narrow	Natural	250	275	225
79270.W0030-1	Rear	Black	Narrow	Natural	300	325	275
79270.W0035-1	Rear	Black	Narrow	Natural	350	375	325
79270.W0040-1	Rear	Black	Narrow	Natural	400	425	375
79270.W0050-1	Rear	Black	Narrow	Natural	500	525	475
79270.W0060-1	Rear	Black	Wide	Natural	600	625	575
79270.W0520-1	Rear	Black	Wide	Natural	200	250	150
79270.W0525-1	Rear	Black	Wide	Natural	250	300	200
79270.W0530-1	Rear	Black	Wide	Natural	300	350	250
79270.W0535-1	Rear	Black	Wide	Natural	350	400	300
79270.W0540-1	Rear	Black	Wide	Natural	400	450	350
79270.W0550-1	Rear	Black	Wide	Natural	500	550	450
79270.W0560-1	Rear	Black	Wide	Natural	600	650	550
79270.W0020-4	Front	Black	Narrow	Black	200	225	175
79270.W0025-4	Front	Black	Narrow	Black	250	275	225
79270.W0030-4	Front	Black	Narrow	Black	300	325	275
79270.W0035-4	Front	Black	Narrow	Black	350	375	325
79270.W0040-4	Front	Black	Narrow	Black	400	425	375
79270.W0050-4	Front	Black	Narrow	Black	500	525	475
79270.W0060-4	Front	Black	Narrow	Black	600	625	575

Order No.	a_1	a_2	b_1	b_2	d_1	h_1	t_1	w_1
79270.W0020-1	Ø30 x 1,5	33	15	45	M 8	50	15	25
79270.W0025-1	Ø30 x 1,5	33	15	45	M 8	50	15	25
79270.W0030-1	Ø30 x 1,5	33	15	45	M 8	50	15	25
79270.W0035-1	Ø30 x 1,5	33	15	45	M 8	50	15	25
79270.W0040-1	Ø30 x 1,5	33	15	45	M 8	50	15	25
79270.W0050-1	Ø30 x 1,5	33	15	45	M 8	50	15	25
79270.W0060-1	Ø30 x 1,5	33	15	45	M 8	50	15	25
79270.W0520-1	Ø30 x 1,5	33	15	45	M 8	50	15	50
79270.W0525-1	Ø30 x 1,5	33	15	45	M 8	50	15	50
79270.W0530-1	Ø30 x 1,5	33	15	45	M 8	50	15	50



Order No.	a ₁	a ₂	b ₁	b ₂	d ₁	h ₁	t ₁	w ₁
79270.W0535-1	Ø30 x 1,5	33	15	45	M 8	50	15	50
79270.W0540-1	Ø30 x 1,5	33	15	45	M 8	50	15	50
79270.W0550-1	Ø30 x 1,5	33	15	45	M 8	50	15	50
79270.W0560-1	Ø30 x 1,5	33	15	45	M 8	50	15	50
79270.W0020-4	Ø30 x 1,5	33	15	45	M 6 x 45	50	15	25
79270.W0025-4	Ø30 x 1,5	33	15	45	M 6 x 45	50	15	25
79270.W0030-4	Ø30 x 1,5	33	15	45	M 6 x 45	50	15	25
79270.W0035-4	Ø30 x 1,5	33	15	45	M 6 x 45	50	15	25
79270.W0040-4	Ø30 x 1,5	33	15	45	M 6 x 45	50	15	25
79270.W0050-4	Ø30 x 1,5	33	15	45	M 6 x 45	50	15	25
79270.W0060-4	Ø30 x 1,5	33	15	45	M 6 x 45	50	15	25

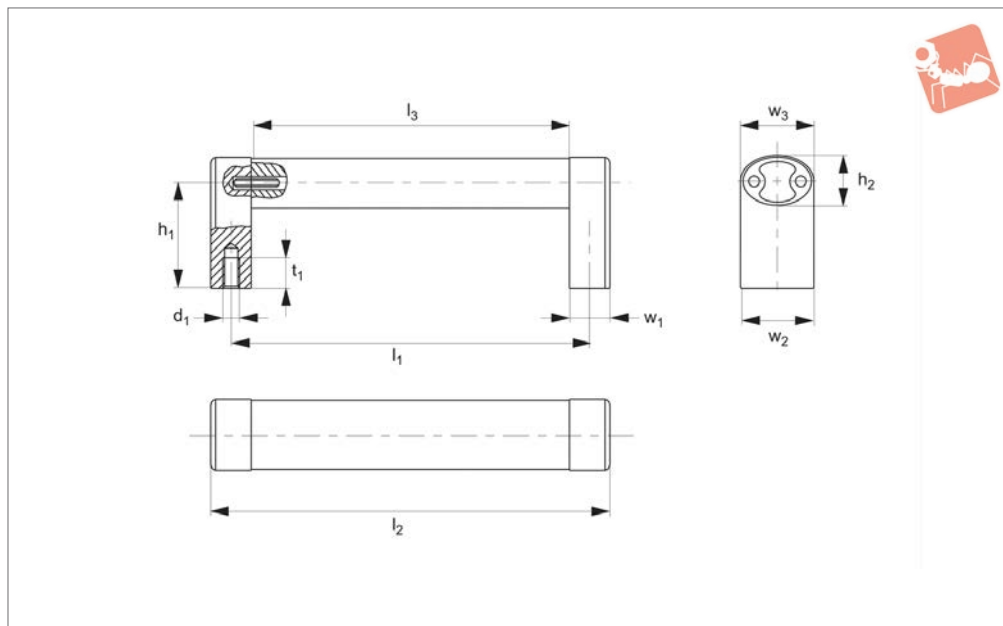

79280

PULL HANDLES

Material

Handle shank and connecting tube:
extruded aluminium Al Mg Si 0,5. Anodised
matt, natural or black.

Technical Notes

Minimum stress resistance >1000N.

Important Notes

Other handle lengths or colour combina-
tions on request.

Order No.	Colour	l_1	l_2	l_3	d_1	h_1	h_2	t_1	w_1	w_2	w_3
79280.W0200-1	Natural	200	220	180	M 8	52	25	15	20	36	35
79280.W0200-4	Black	200	220	180	M 8	52	25	15	20	36	35
79280.W0250-1	Natural	250	270	230	M 8	52	25	15	20	36	35
79280.W0250-4	Black	250	270	230	M 8	52	25	15	20	36	35
79280.W0300-1	Natural	300	320	280	M 8	52	25	15	20	36	35
79280.W0300-4	Black	300	320	280	M 8	52	25	15	20	36	35
79280.W0400-1	Natural	400	420	380	M 8	52	25	15	20	36	35
79280.W0400-4	Black	400	420	380	M 8	52	25	15	20	36	35
79280.W0500-1	Natural	500	520	480	M 8	52	25	15	20	36	35
79280.W0500-4	Black	500	520	480	M 8	52	25	15	20	36	35



79290

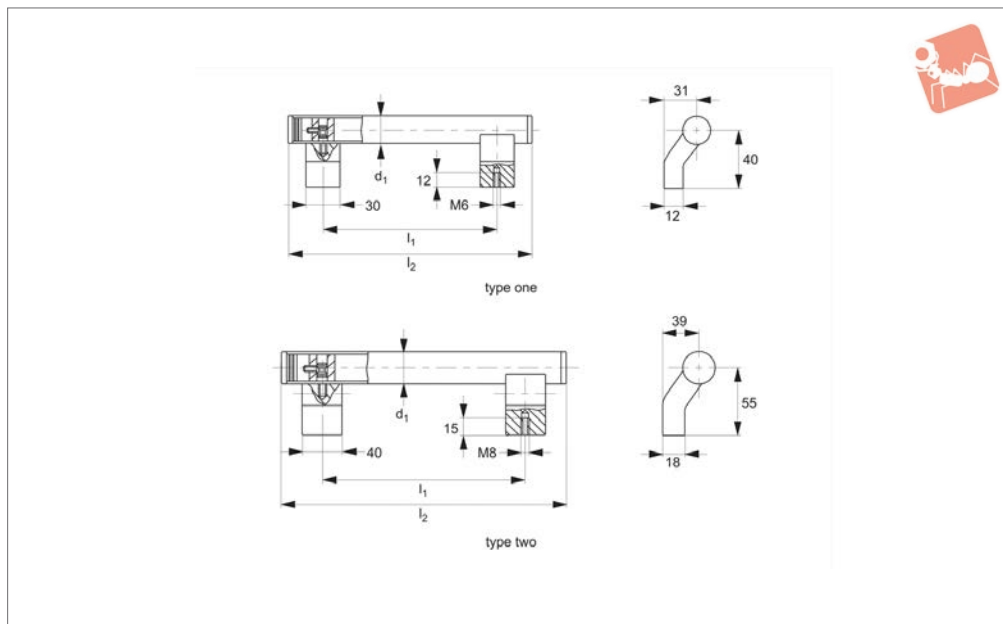

Material

Type one: handle shank and connecting tube - extruded aluminium Al Mg Si 0,5. Anodized, natural or black. Fixing sleeves of anodised aluminium, clamping screws and pegs made of stainless steel.

Type two: handle shank - extruded aluminium Al Mg Si 0,5, anodized black. Connecting tube: stainless steel.

Technical Notes

Minimum stress resistance >1000N.

Important Notes

Other handle lengths or colours combinations on request.

Order No.	Colour	Type	l ₁	l ₂	d ₁
79290.W0220-1	Natural	One	200	260	20 x 2,0
79290.W0220-4	Black	One	200	260	20 x 2,0
79290.W0225-1	Natural	One	250	310	20 x 2,0
79290.W0225-4	Black	One	250	310	20 x 2,0
79290.W0230-1	Natural	One	300	360	20 x 2,0
79290.W0230-4	Black	One	300	360	20 x 2,0
79290.W0330-1	Natural	Two	300	390	30 x 1,5
79290.W0330-4	Black	Two	300	390	30 x 1,5
79290.W0335-1	Natural	Two	350	440	30 x 1,5
79290.W0335-4	Black	Two	350	440	30 x 1,5
79290.W0340-1	Natural	Two	400	490	30 x 1,5
79290.W0340-4	Black	Two	400	490	30 x 1,5
79290.W0350-1	Natural	Two	500	590	30 x 1,5
79290.W0350-4	Black	Two	500	590	30 x 1,5
79290.W0360-1	Natural	Two	600	690	30 x 1,5
79290.W0360-4	Black	Two	600	690	30 x 1,5

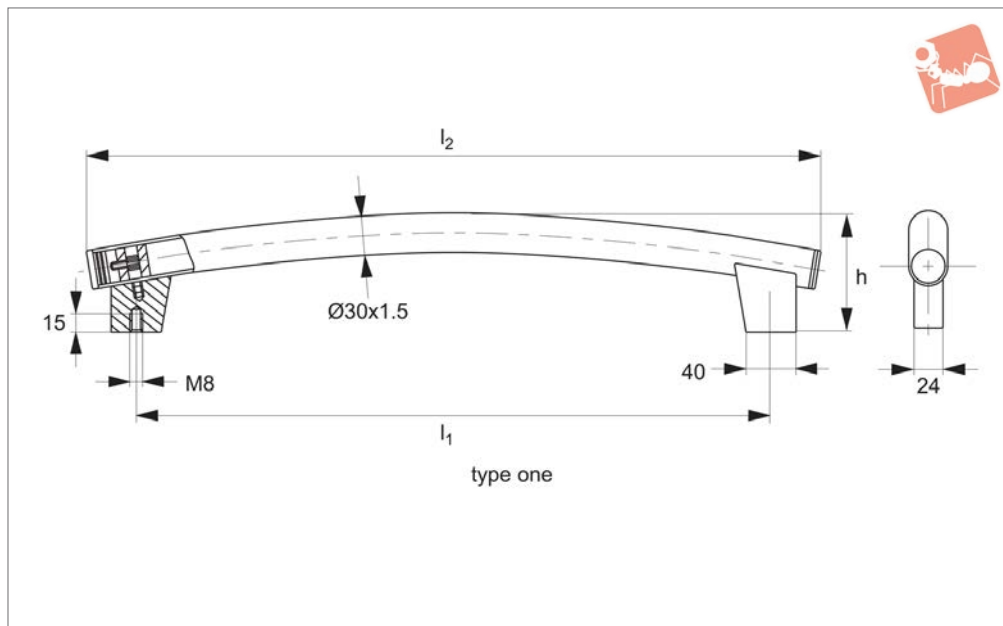

79310

PULL HANDLES

Material

Connecting tube: stainless steel fine ground, material 1.4301. Tube Ø30 x 1.5mm, end caps material no 1.4305, stainless steel, fine ground.

Tube holders: aluminium, AlMgSi 0.5 powder coated with fine structure.

design. Minimum stress resistance > 1000N.

Technical Notes

Bent tube handle in modern industrial

Order No.	Type	l_1	l_2	h
79310.W0500	One	500	600	90
79310.W0600	One	600	700	100

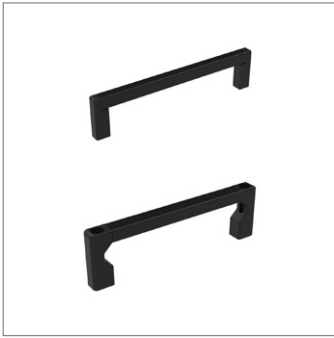

79350

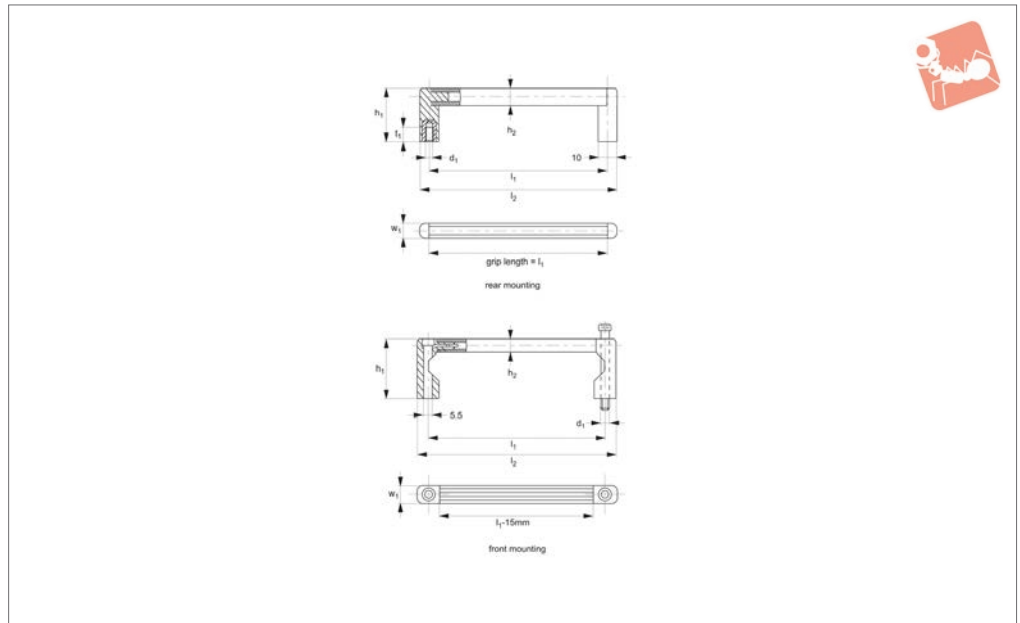

Material

Connection tube: special aluminium section, matt finishing in natural colour or black anodized.

Handle shank: heavy-duty polyamide,

glass bead reinforced with fine structure and brass threaded bush. Screw attachment from front, steel plate reinforced.

Technical Notes

Minimum stress resistance 200N.

Tips

For small appliances, front panels and

Order No.	Colour	Type	l_1	l_2	d_1	h_1	h_2	t_1	w_1
79350.W0032-1	Natural	Rear Mounting	32	42	M 4	30	9	8	8
79350.W0055-1	Natural	Rear Mounting	55	65	M 4	30	9	8	8
79350.W0062-1	Natural	Rear Mounting	62	72	M 4	30	9	8	8
79350.W0086-1	Natural	Rear Mounting	86	96	M 4	30	9	8	8
79350.W0088-1	Natural	Rear Mounting	88	98	M 4	30	9	8	8
79350.W0090-1	Natural	Rear Mounting	90	100	M 4	30	9	8	8
79350.W0120-1	Natural	Rear Mounting	120	130	M 4	30	9	8	8
79350.W0134-1	Natural	Rear Mounting	134	144	M 4	30	9	8	8
79350.W0032-4	Black	Rear Mounting	32	42	M 4	30	9	8	8
79350.W0055-4	Black	Rear Mounting	55	65	M 4	30	9	8	8
79350.W0062-4	Black	Rear Mounting	62	72	M 4	30	9	8	8
79350.W0086-4	Black	Rear Mounting	86	96	M 4	30	9	8	8
79350.W0088-4	Black	Rear Mounting	88	98	M 4	30	9	8	8
79350.W0090-4	Black	Rear Mounting	90	100	M 4	30	9	8	8
79350.W0120-4	Black	Rear Mounting	120	130	M 4	30	9	8	8
79350.W0134-4	Black	Rear Mounting	134	144	M 4	30	9	8	8
79350.W0255-1	Natural	Front Mounting	55	70	M 5	40	9	-	12
79350.W0288-1	Natural	Front Mounting	88	103	M 5	40	9	-	12
79350.W0300-1	Natural	Front Mounting	100	115	M 5	40	9	-	12
79350.W0320-1	Natural	Front Mounting	120	135	M 5	40	9	-	12
79350.W0380-1	Natural	Front Mounting	180	195	M 5	40	9	-	12
79350.W0435-1	Natural	Front Mounting	235	250	M 5	40	9	-	12
79350.W0255-4	Black	Front Mounting	55	70	M 5	40	9	-	12
79350.W0288-4	Black	Front Mounting	88	103	M 5	40	9	-	12
79350.W0300-4	Black	Front Mounting	100	115	M 5	40	9	-	12
79350.W0320-4	Black	Front Mounting	120	135	M 5	40	9	-	12
79350.W0380-4	Black	Front Mounting	180	195	M 5	40	9	-	12
79350.W0435-4	Black	Front Mounting	235	250	M 5	40	9	-	12

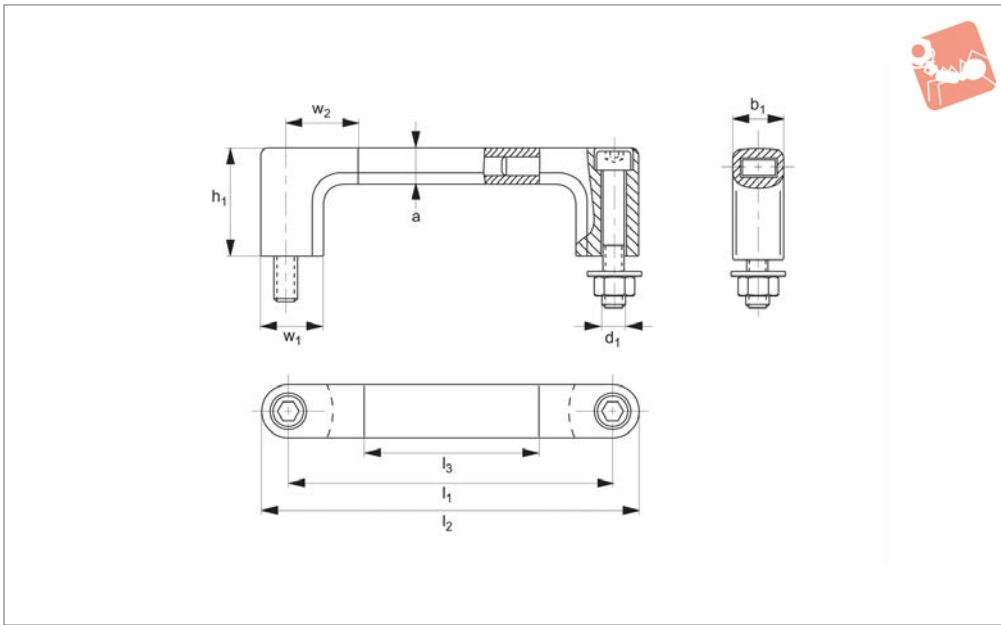

79360

PULL HANDLES

Material

Connection shank: die-cast aluminium, black powder coated, semi-matte.
 Connection tube: die-cast aluminium, anodised, natural, satin finish. RAL 7043.

Technical Notes

Supplied with hex screw DIN 912, M12x70

with suitable nuts and washers.
 Minimum stress resistance >1000N.

Tips

Machine, instrument and equipment handles for universal use and for any hole spacing.
 Extra rugged design. Handle ledge and

elbow section plug press-connected.

Order No.	l_1	l_2	l_3	a_1	b_1	d_1	h_1	w_1	w_2
79360.W0180	180	208	100	20	28	M 12	60	34	40
79360.W0200	200	228	220	20	28	M 12	60	34	40
79360.W0250	250	278	170	20	28	M 12	60	34	40
79360.W0300	300	328	220	20	28	M 12	60	34	40
79360.W0350	350	378	270	20	28	M 12	60	34	40
79360.W0400	400	428	320	20	28	M 12	60	34	40
79360.W0500	500	528	420	20	28	M 12	60	34	40
79360.W0600	600	628	520	20	28	M 12	60	34	40



79380

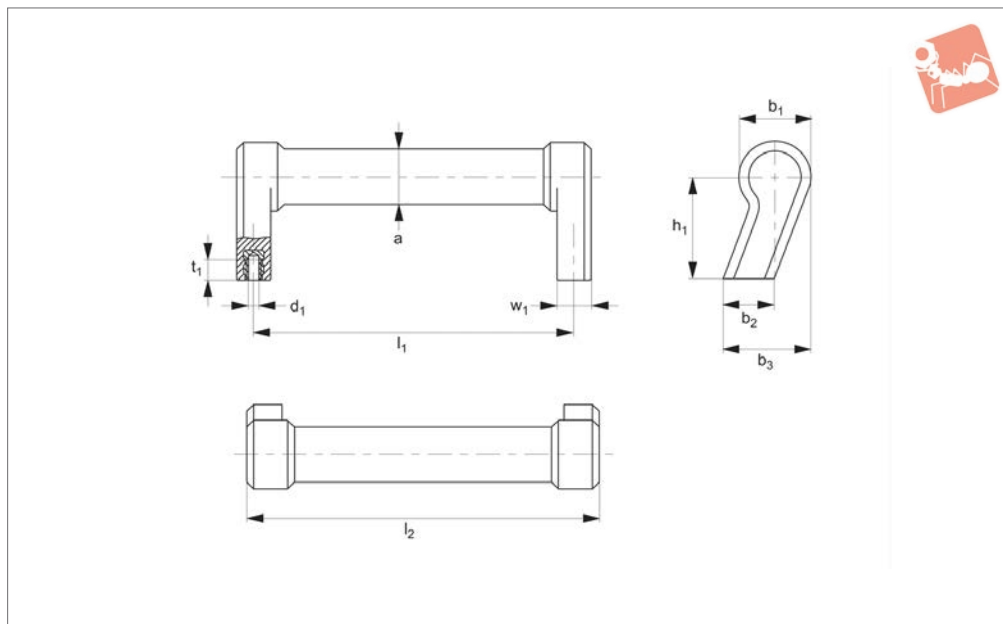

Material

Handle of polyamide PA 6, glass ball reinforced with threaded brass bushings.

Black or light grey semi matte with fine-grain structure.

Technical Notes

Stress resistance: min. 1000N.

Order No.	Finish	l_1	l_2	a	b_1	b_2	b_3	d_1	h_1	t_1	w_1
79380.W0140-4	Black	140	155	Ø24	30	22	37	M 6	45	9	15
79380.W0140-7	Light grey	140	155	Ø24	30	22	37	M 6	45	9	15



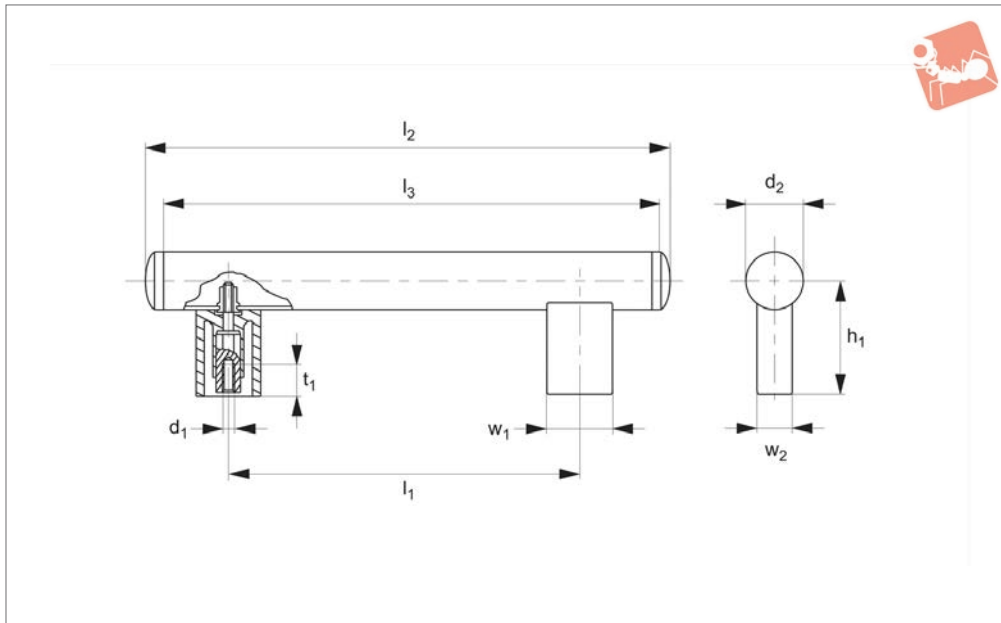
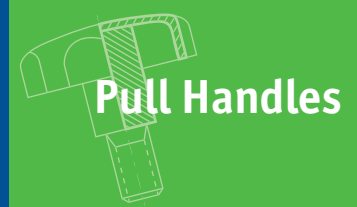

79400

PULL HANDLES

Material

Connection shank: Polyamide (PA 6), glass bead reinforced, black, semi-matte. With steel threaded insert.

Connection tube: aluminium Al Mg Si 0,5, Ø30x1,5mm. Precision ground and

anodised.

Technical Notes

Minimum stress resistance 800N.

Tips

Screwed connection from the shank to the

tube with non-detachable blind rivet to prevent it being pulled off.

Important Notes

Handle lengths and screw down spacers available as required on request.

Order No.	Colour	l_1	l_2	l_3	d_1	d_2	h_1	t_1	w_1	w_2
79400.W0200-1	Natural	200	288	270	M 6	30 x 1,5	60	17	34	20
79400.W0200-4	Black	200	288	270	M 6	30 x 1,5	60	17	34	20
79400.W0250-1	Natural	250	338	320	M 6	30 x 1,5	60	17	34	20
79400.W0250-4	Black	250	338	320	M 6	30 x 1,5	60	17	34	20
79400.W0300-1	Natural	300	388	370	M 6	30 x 1,5	60	17	34	20
79400.W0300-4	Black	300	388	370	M 6	30 x 1,5	60	17	34	20
79400.W0350-1	Natural	350	438	420	M 6	30 x 1,5	60	17	34	20
79400.W0350-4	Black	350	438	420	M 6	30 x 1,5	60	17	34	20
79400.W0400-1	Natural	400	488	470	M 6	30 x 1,5	60	17	34	20
79400.W0400-4	Black	400	488	470	M 6	30 x 1,5	60	17	34	20
79400.W0500-1	Natural	500	588	570	M 6	30 x 1,5	60	17	34	20
79400.W0500-4	Black	500	588	570	M 6	30 x 1,5	60	17	34	20



79410

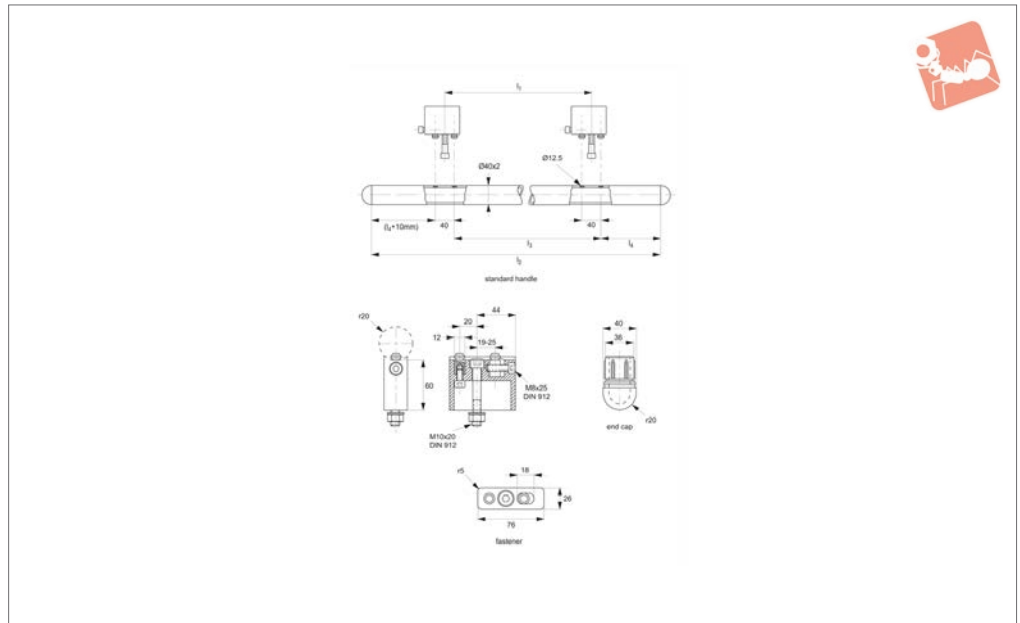

Material

Connection shank: die-cast aluminium, black powder coated, silk matte.
 Connection tube: stainless steel 1.4301, Ø40x2, precision ground.
 End cap: polyamide (PA 6), glass ball reinforced, black, silk matte.

Technical Notes

Simplest fixing of components from the front. The same length handle can be fixed at any support spacing.
 Minimum stress resistance >1000N.

Tips

Heavy-duty pipe handles for mechanical and process equipment engineering purposes. Part nos. 79410.W0380 to .W0700 supplied complete with two fasteners and end caps.

Order No.	Type	l ₁	l ₂	l ₃	l ₄
79410.W0380	Handle	380	600	380	85
79410.W0480	Handle	480	700	480	85
79410.W0500	Handle	500	800	500	125
79410.W0600	Handle	600	900	600	125
79410.W0700	Handle	700	1000	700	125
79410.W0901	Fastener	-	-	-	-
79410.W0902	End Cap	-	-	-	-



Pull Handles - Heavy Duty

stainless steel and plastic

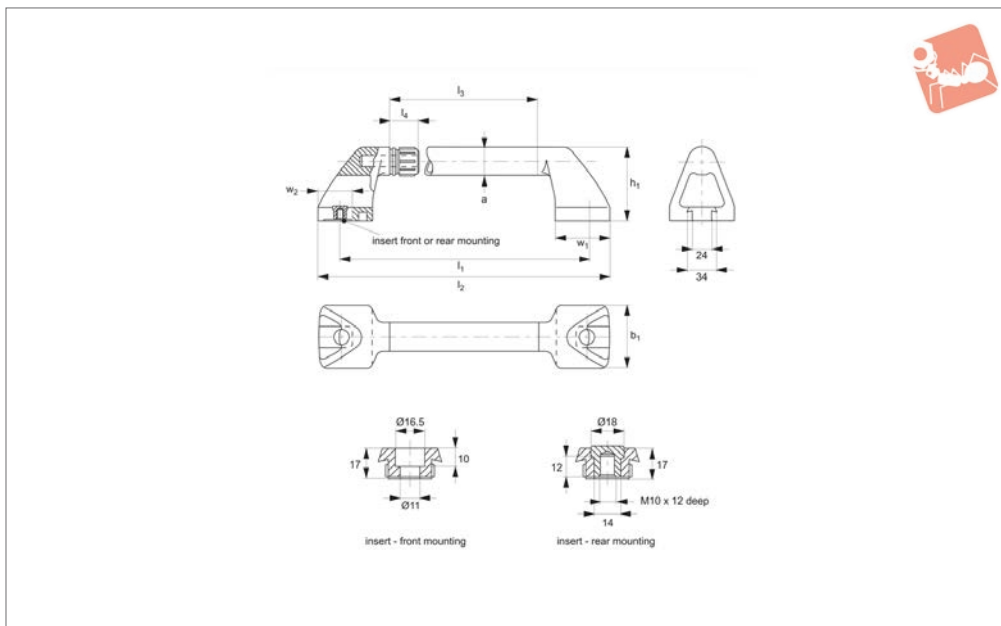

79420

PULL HANDLES

Material

Handle shank: polyamide (PA 6), glass ball reinforced, black, silk matte finish.
 Connection tube: stainless steel 1.4301 AISI 304, pipe Ø35x2mm, precision ground.

Technical Notes

Front mounting: supplied with stainless

steel hex screws DIN 912, M10x25 and suitable nuts and washers.

Rear mounting: no screws supplied.
 Minimum stress resistance >1000N.

Tips

Clamp ridges on handle shanks hold connection tube firmly, O-rings provide splash proof water tight seal. Any handle

length on request.

Order No.	Type	l_1	l_2	l_3	l_4	a	b_1	h_1	w_1	w_2
79420.W0300	Front Mounting	300	350	180	35	35 x 2	80	90	62	40
79420.W0301	Rear Mounting	300	350	180	35	35 x 2	80	90	62	40
79420.W0350	Front Mounting	350	400	230	35	35 x 2	80	90	62	40
79420.W0351	Rear Mounting	350	400	230	35	35 x 2	80	90	62	40
79420.W0400	Front Mounting	400	450	280	35	35 x 2	80	90	62	40
79420.W0401	Rear Mounting	400	450	280	35	35 x 2	80	90	62	40
79420.W0450	Front Mounting	450	500	330	35	35 x 2	80	90	62	40
79420.W0451	Rear Mounting	450	500	330	35	35 x 2	80	90	62	40
79420.W0500	Front Mounting	500	550	380	35	35 x 2	80	90	62	40
79420.W0501	Rear Mounting	500	550	380	35	35 x 2	80	90	62	40
79420.W0600	Front Mounting	600	650	480	35	35 x 2	80	90	62	40
79420.W0601	Rear Mounting	600	650	480	35	35 x 2	80	90	62	40
79420.W0700	Front Mounting	700	750	580	35	35 x 2	80	90	62	40
79420.W0701	Rear Mounting	700	750	580	35	35 x 2	80	90	62	40
79420.W0800	Front Mounting	800	850	680	35	35 x 2	80	90	62	40
79420.W0801	Rear Mounting	800	850	680	35	35 x 2	80	90	62	40
79420.W0901	Handle Shank	-	-	-	-	-	-	-	-	-
79420.W0902	Front Mounting Insert	-	-	-	-	-	-	-	-	-
79420.W0903	Rear Mounting Insert	-	-	-	-	-	-	-	-	-

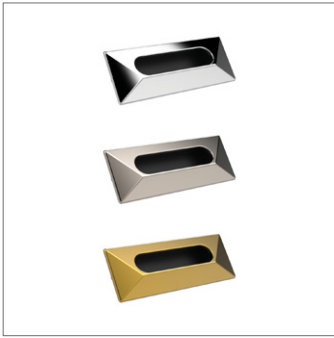

79440

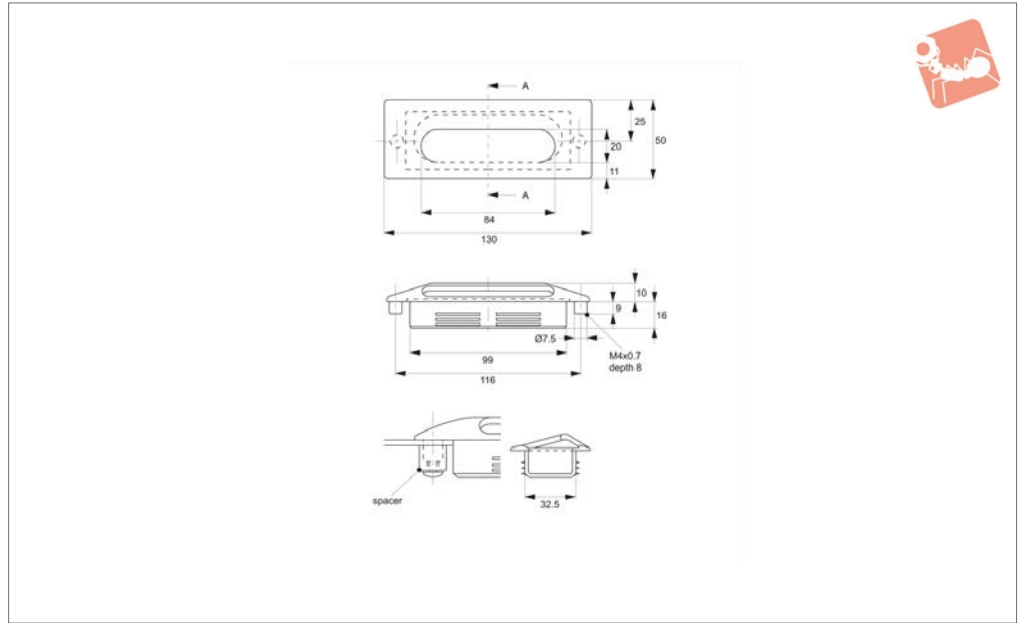

Material

Body: black plastic.

Cover: zinc alloy, chrome, satin nickel or

satin brass finish.

Technical Notes

Supplied with spacer and screws (M4x8).

Order No.	Finish	Weight g
79440.W0130	Chrome	105
79440.W0131	Nickel, Satin	105
79440.W0132	Brass, Satin	105

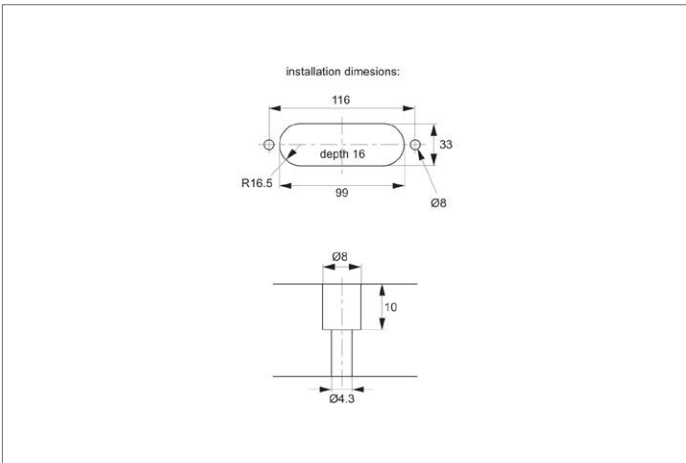



Recessed Pull Handles stainless steel

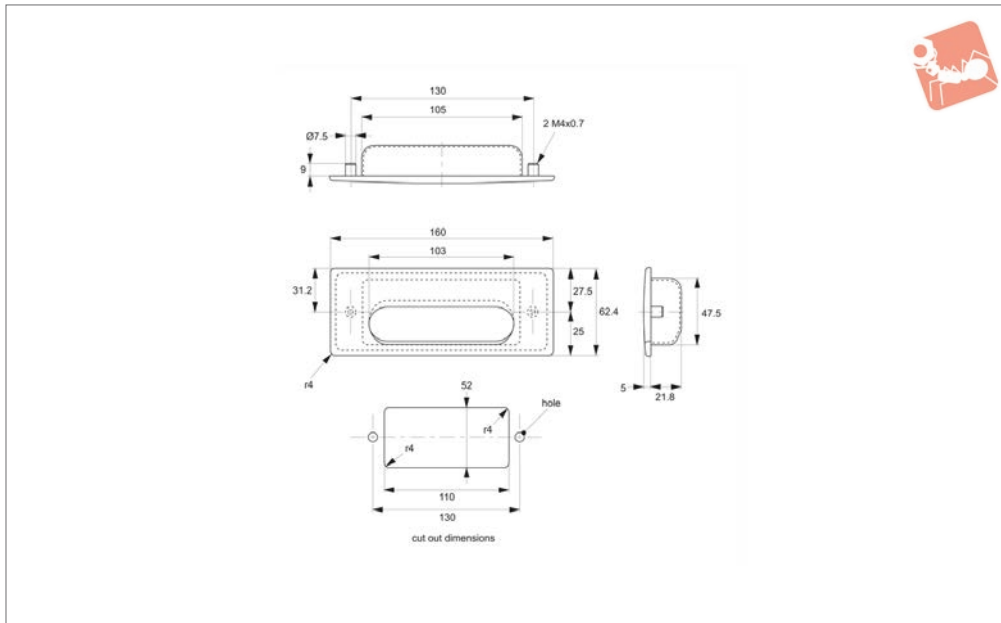

79460

PULL HANDLES

Material

AISA 304 stainless steel, satin finish.

Technical Notes

M 4 mounting screws required, not

supplied.

Important Notes

Ideal for harsh and high corrosive environments.

Order No.	Type	Weight g
79460.W0160	Stainless Steel	260



79470

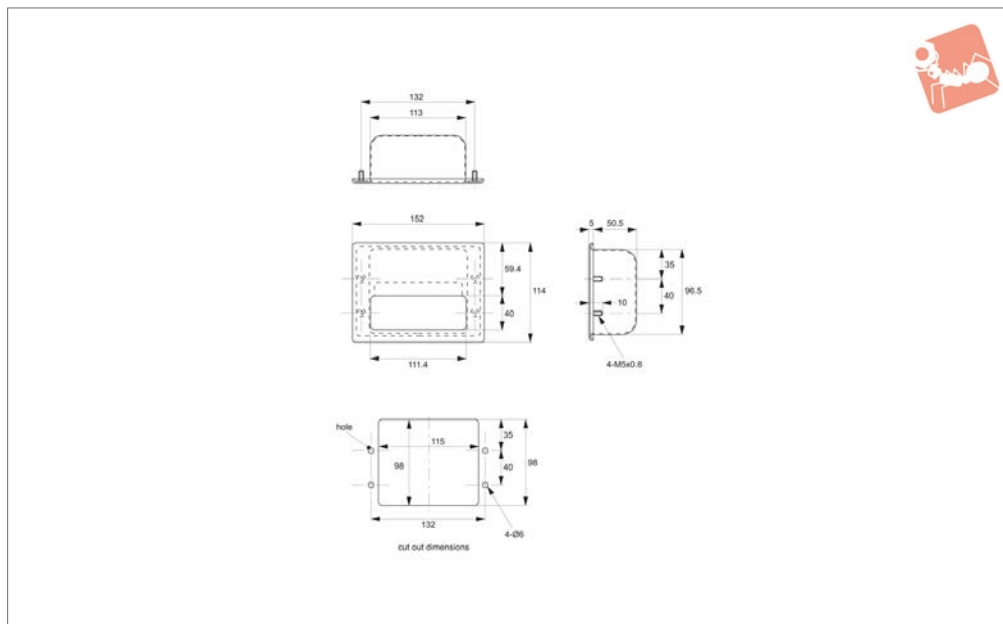

Material

AISI 304 stainless steel, satin finish.

Technical Notes

Supplied with stainless steel M 5 nut.

Order No.

79470.W0150

Finish

Stainless Steel

Weight

g
390



Pull Handles - Recessed

stainless steel - rear mounting

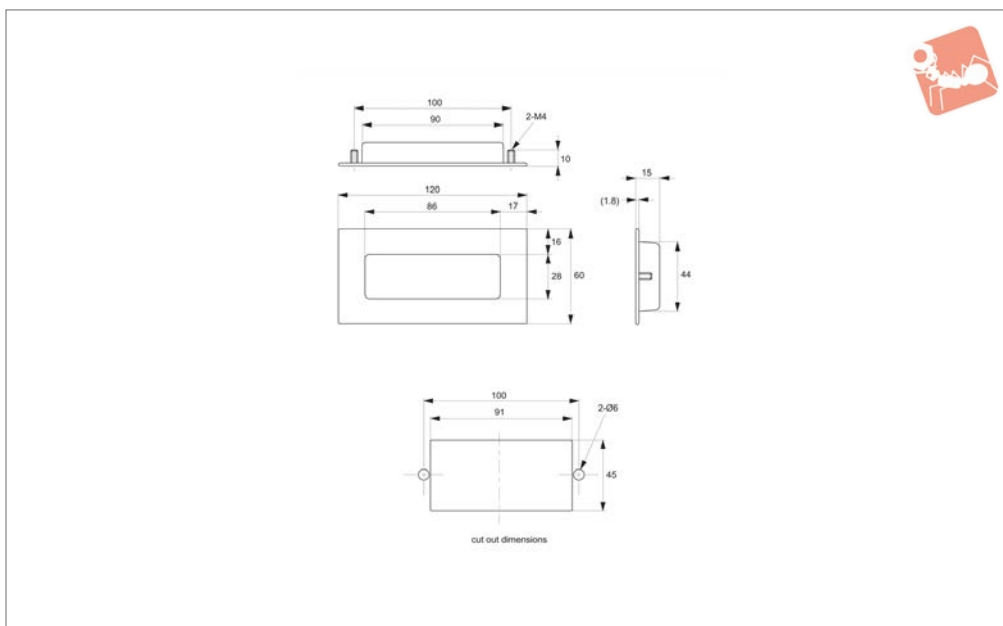

79480

PULL HANDLES

Material

Stainless steel, AISI 304, satin finish.

Technical Notes

Supplied with stainless steel M 4 nut.

Order No.	Finish	Weight
79480.W0010	Stainless Steel	g 50



79490

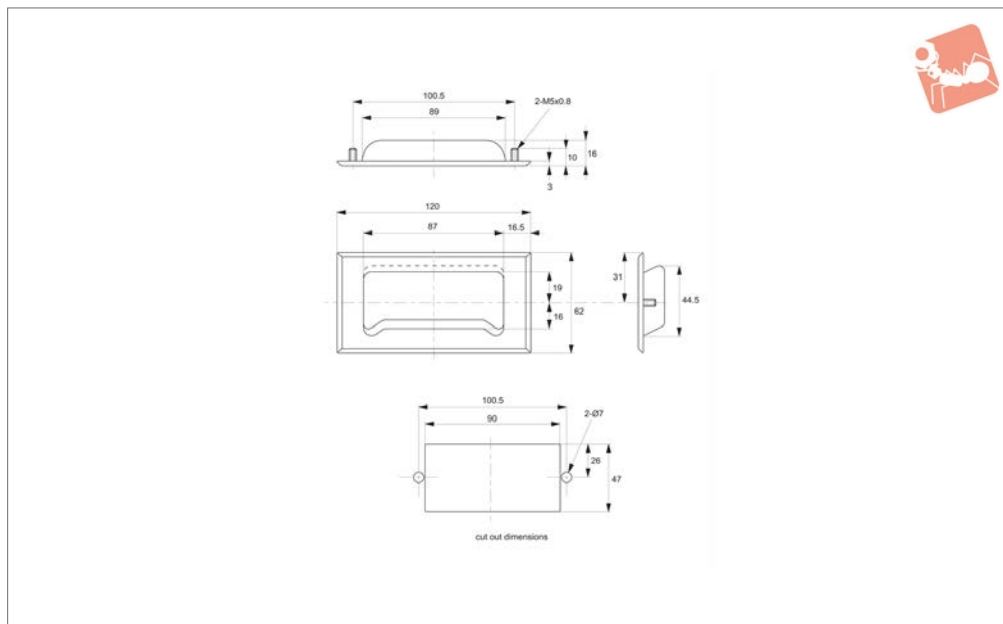

Material

AISI 304 stainless steel, satin finish.

Technical Notes

Supplied with clear zinc chromate M 5 nuts.

Order No.

79490.W0010

Finish

Stainless Steel

Weight

g
50

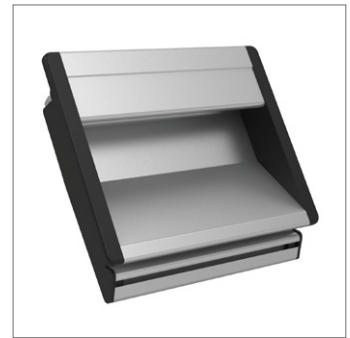
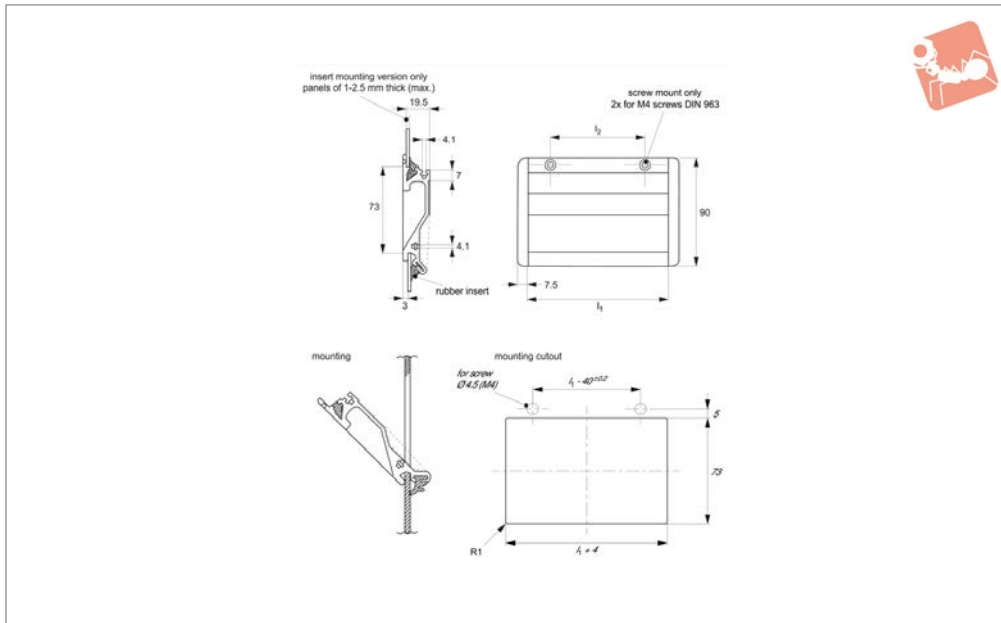
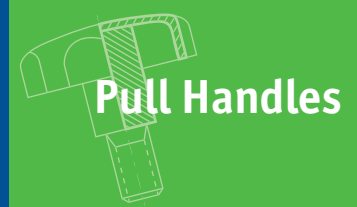

79500

PULL HANDLES

Material

Profiled aluminium, with black polyamide end caps PA 6. Handle glass blasted and anodised, natural or black, satin finish.

Technical Notes

Two possible mounting options:

1) Mounting via screws (for panels

>2,5mm thick): two countersunk holes for DIN966, M4x8 included on model.

2) Mounting via rubber insert (for panels

1 to 2,5mm thick): additional rubber insert at top of the handle pushes in from the back, securing the handle. Minimum stress resistance 500N.

Tips

Mounting method:

- Make mounting cut-out in panel/material.
- Insert bottom rubber insert.
- Attach end caps.

- Press handle over lower edge of mounting cut-out at a 45° angle, ensuring correct position of rubber insert on the inside of the cut-out.

- If using additional rubber insert for mounting, hold handle against cut-out and fit insert. Alternatively use two countersunk screws with spacing equal to $l_1 - 40\text{mm}$ (as shown).

Order No.	Type	Finish	l_1	l_2	Mounting cutout
79500.W0100-1	Screw	Silver	100	60	104x73
79500.W0100-4	Screw	Black	100	60	104x73
79500.W0118-1	Screw	Silver	118	78	122x73
79500.W0118-4	Screw	Black	118	78	122x73
79500.W0167-1	Screw	Silver	167	127	171x73
79500.W0167-4	Screw	Black	167	127	171x73
79500.W0500-1	Insert	Silver	100	60	104x73
79500.W0500-4	Insert	Black	100	60	104x73
79500.W0618-1	Insert	Silver	118	78	122x73
79500.W0618-4	Insert	Black	118	78	122x73
79500.W0667-1	Insert	Silver	167	127	171x73
79500.W0667-4	Insert	Black	167	127	171x73



79510

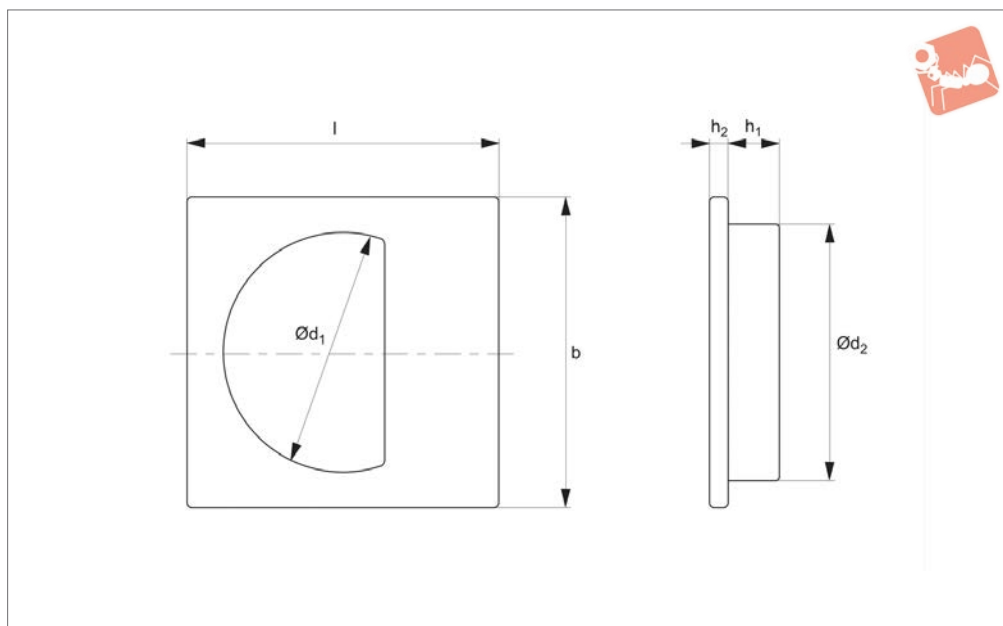

Material

Stainless type: AISI 304 stainless steel, polished.

Technical Notes

Press fit.

Order No.	Finish	l	b	h ₁	h ₂	Ø d ₁	Ø d ₂	Weight g
79510.W0035	Stainless	44	44	9.8	2.2	31	35.1	10
79510.W0038	Stainless	47	47	10.3	2.2	34	37.6	11
79510.W0048	Stainless	57	57	10.3	2.2	44	48.6	16

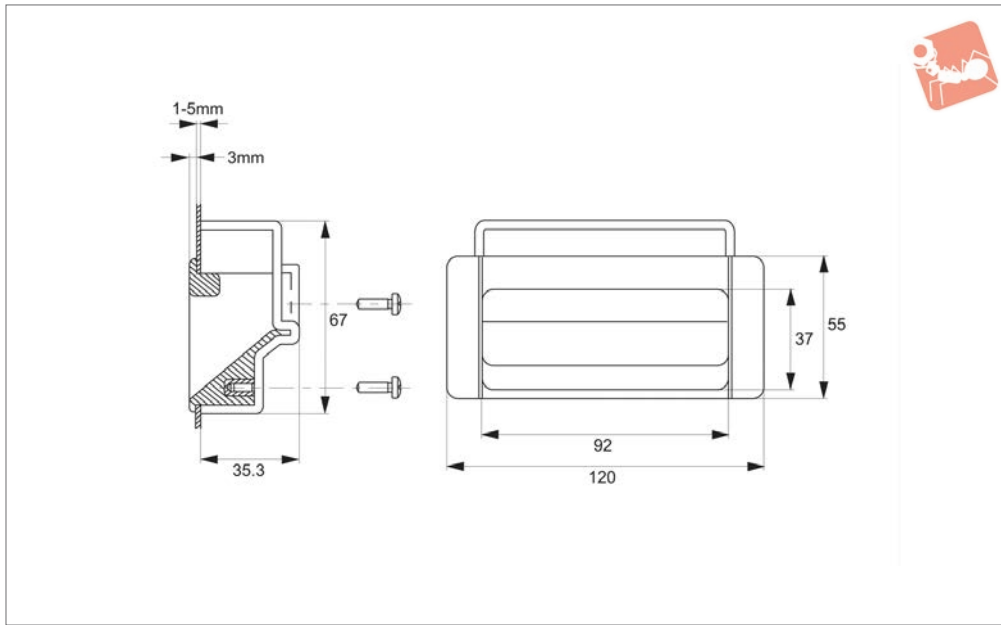

79520

PULL HANDLES

Material

Thermoplastic PA 6, glass bead reinforcement, fine-grain structure.
Threaded brass insert.

Technical Notes

Mounting: the front section is first set into

the mounting cut-out. The rear section is then fitted to front section from the interior of the panel, and fixed with three screws (supplied).
Minimum stress resistance 1000N.

Tips

This handle is suitable for different degrees of panel thickness 1 to 5mm. Its design guarantees that it fits securely at all times.

Order No.

79520.W0107
79520.W0108
79520.W0109

Finish

Stone Grey
Light Grey
Greyish White

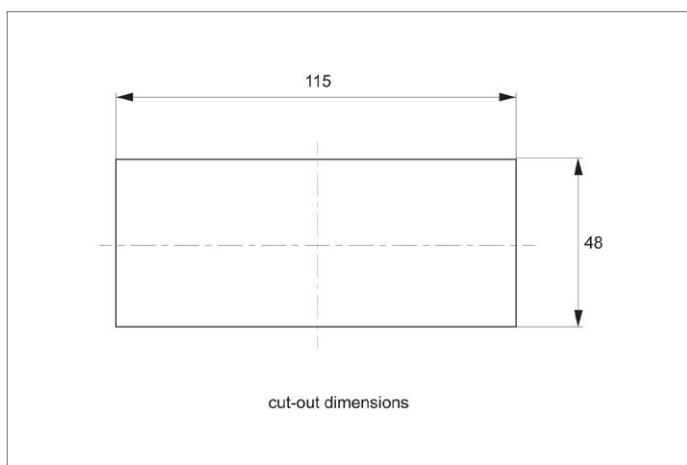



PULL HANDLES



79522

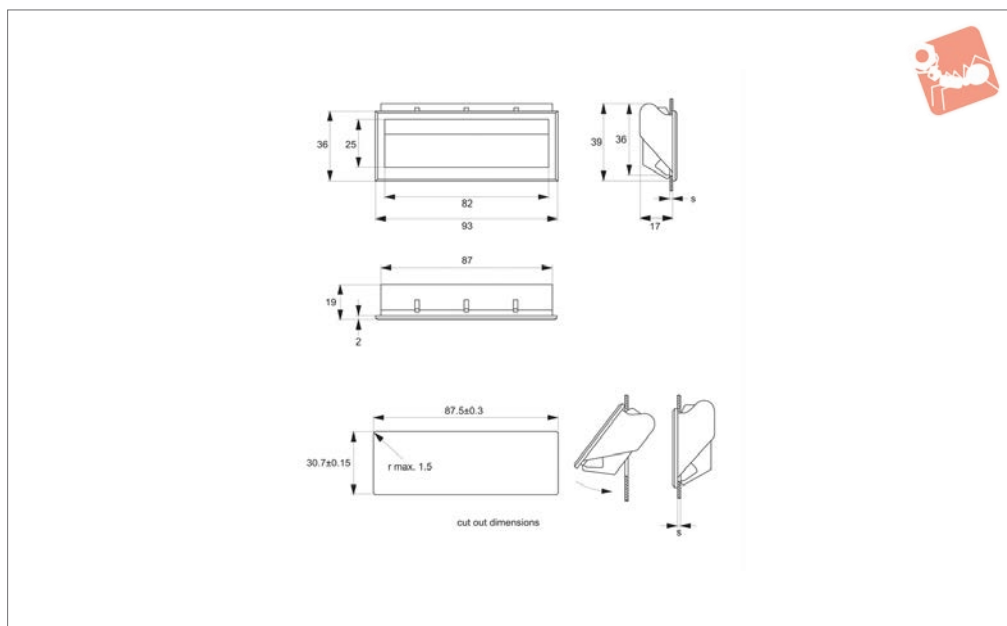

Material

ABS resin, black, similar to RAL 9005, with fine structure on the visible surfaces.

Technical Notes

Flush inset handle for lifting and pulling. Unilateral, tool-less single-hole installation through self-locking, recessed handle.

Stress resistance: min. 400N when installed in 1,2mm sheet steel. Max. values depend on the strength of the mounting wall.

Tips

Assembly: place the trough inset handle in the cutout, so that the upper edge of the

cutout lies in the gap being the face of the handle. Then press the bottom edge of the handle into the cutout until it clearly locks into place.

Order No.

Panel thickness s mm

79522.W0100	1,0-1,4
79522.W0140	1,4-1,8
79522.W0180	1,8-2,1
79522.W0210	2,1-2,5

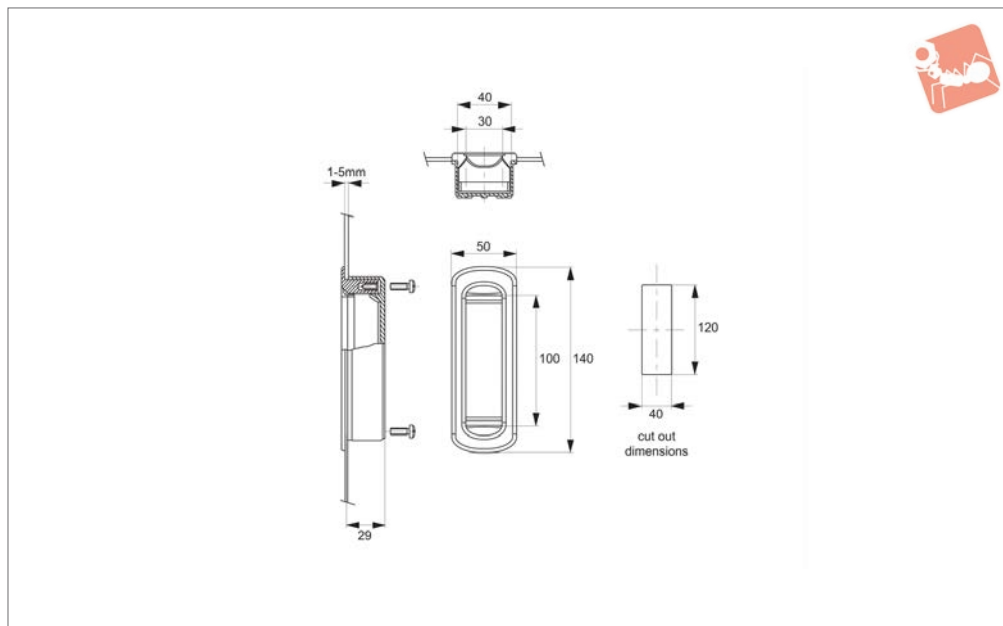

79530

PULL HANDLES

Material

Thermoplast (PA 6), glass bead reinforced. Threaded brass insert. Supplied with four oval-head screws to DIN 7985.

the mounting cut-out. The rear section is then fitted to front section from the interior of the panel, and fixed with four screws (supplied).

1 to 5mm thick.

Technical Notes

Mounting: the front section is first set into

Tips

Simple and stable design for use on panels

Order No.

- 79530.W0107
- 79530.W0108
- 79530.W0109
- 79530.W0110

Finish

- Stone Grey
- Light Grey
- Greyish White
- Black

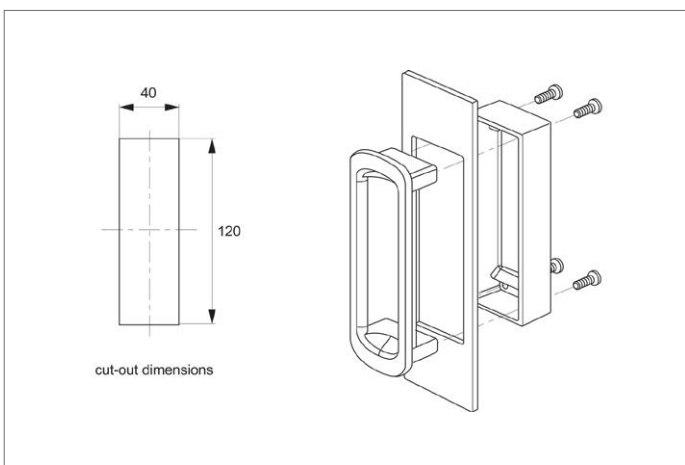



79540

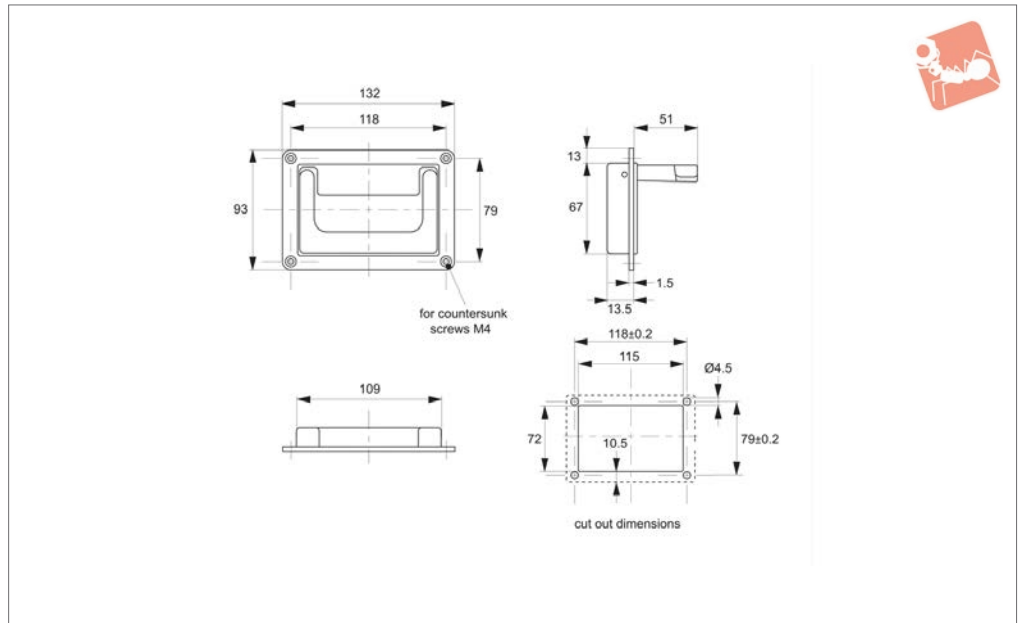

Material

Stainless steel. AISI 304, polished.

Technical Notes

Spring return handle, returns from working

to resting position when released.

See cut-out details for mounting dimensions.

Stress resistance: min. 200N

Order No.	Type	Finish	Hole centres
79540.W0118	Spring Return	Electropolished	118
79540.W0218	Spring Return	Brushed	118

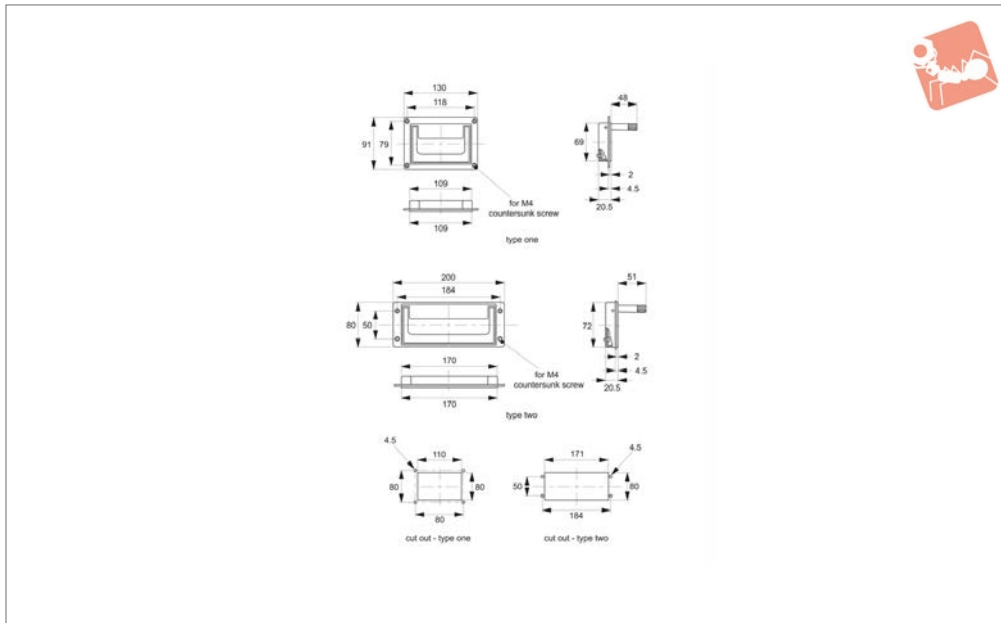

79550

PULL HANDLES

Material

Pressure moulded aluminium, GD Al Si dCu 3.

Technical Notes

Snap-lock type-

with snap lock in both extended and retracted position.

Pull-back type-

with spring retraction from extended to retracted position.

Front or rear mounting possible. Natural finger profiling within the hinged handle. Can also be used for lifting in the retracted position.

Minimum stress resistance 500N.

Tips

Collapsible tray handles are of contemporary design and can be used wherever durability and styling are required.

Order No.	Type	Handle action	Finish
79550.W0118-4	Type One	Snap Lock	Black
79550.W0118-7	Type One	Snap Lock	Light Grey
79550.W0118-9	Type One	Snap Lock	Greyish White
79550.W0119-4	Type One	Pull Back	Black
79550.W0119-7	Type One	Pull Back	Light Grey
79550.W0119-9	Type One	Pull Back	Greyish White
79550.W0184-4	Type Two	Snap Lock	Black
79550.W0184-7	Type Two	Snap Lock	Light Grey
79550.W0184-9	Type Two	Snap Lock	Greyish White
79550.W0185-4	Type Two	Pull Back	Black
79550.W0185-7	Type Two	Pull Back	Light Grey
79550.W0185-9	Type Two	Pull Back	Greyish White



79552

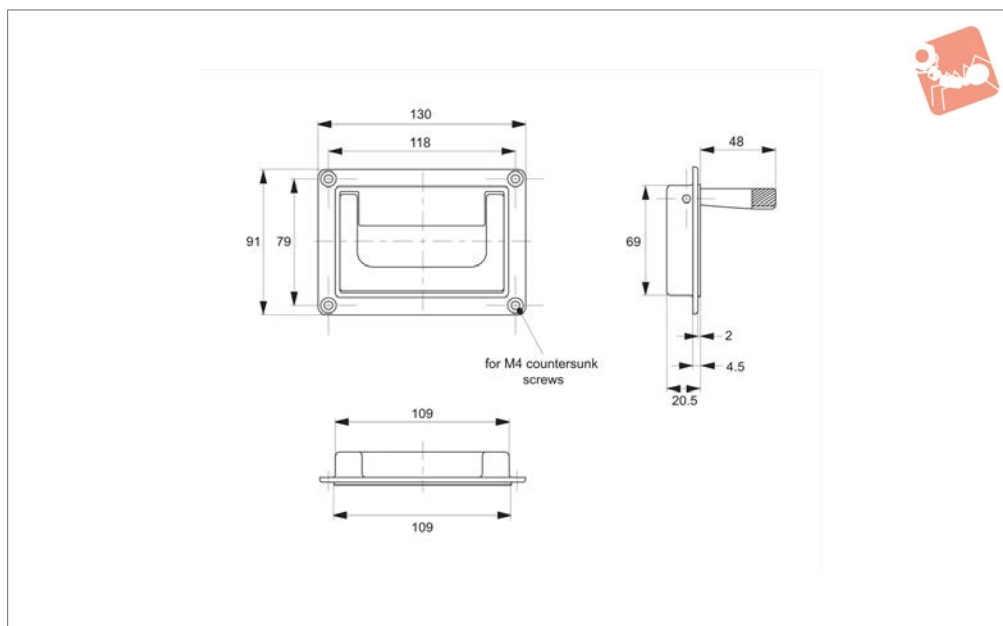

Material

Tray and handle made of polyamide Pa 6, black similar to RAL 9005.

Technical Notes

Mountable in front of or behind housing

wall with the same housing cut-out.
Natural finger profiling at the rear of the hinged handle.

79552.W0118: with snap locks both in rest and work position.

79552.W0218: with pull back spring from the working to the rest position.
Stress resistance: min. 250N.

Order No.	Handle action	Hole centres
79552.W0118	Snap Lock	118
79552.W0218	Pull Back	118

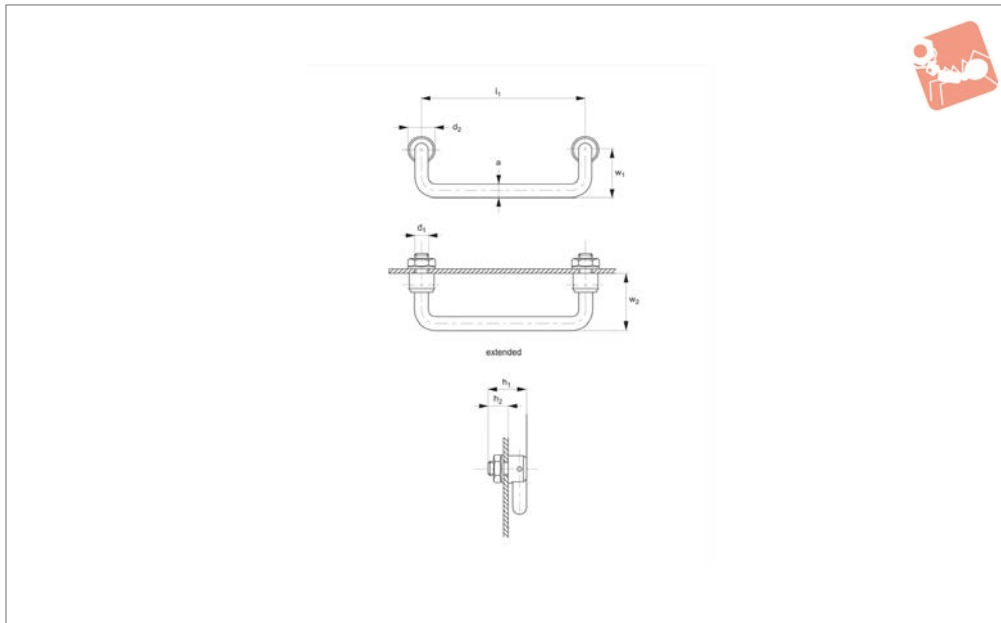

79570

PULL HANDLES

Material

Round steel bar, precision ground and chromium plated, mirror finish. Plastic grip.

Technical Notes

Spring-arrest in both extended and retracted positions. Supplied with suitable nuts and washers.

Minimum stress resistance to 1000N per pair due to one-piece shank.

Order No.	Type	l_1	d_1	d_2	h_1	h_2	a	w_1	w_2
79570.W0100	Without Plastic Grip	100	M10 x 1	18	28	14	Ø10	34	44
79570.W0120	Without Plastic Grip	120	M10 x 1	18	28	14	Ø10	34	44
79570.W0180	Without Plastic Grip	180	M10 x 1	18	28	14	Ø10	34	44
79570.W0500	With Plastic Grip	100	M10 x 1	18	28	14	Ø10	34	44
79570.W0520	With Plastic Grip	120	M10 x 1	18	28	14	Ø10	34	44
79570.W0680	With Plastic Grip	180	M10 x 1	18	28	14	Ø10	34	44



79580

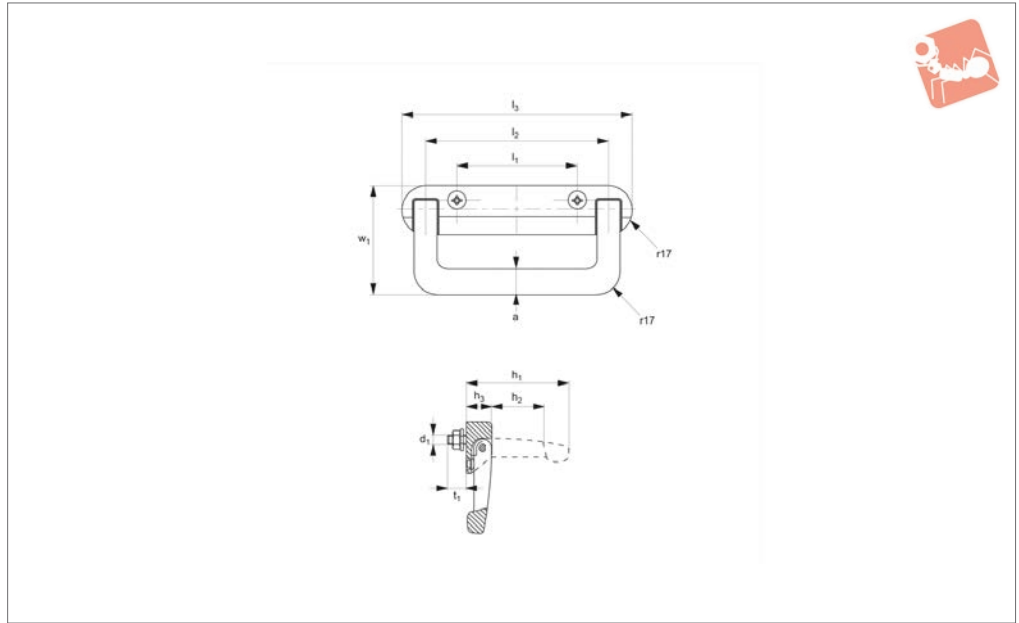

Material

Polyamide, glass reinforced plastic PA 6, black, semi-gloss. Arbors and springs from stainless steel. With screws to DIN9656, M

6x30, suitable nuts & washers.

under load 500N.

Technical Notes

Minimum stress resistance 300N. Stability

Tips

Springs back automatically.

Order No.	Type	l_1	l_2	l_3	d_1	h_1	h_2	h_3	a	t	w_1
79580.W0120	Spring Loaded	80	120	154	M 6	71	35	18	18	12	77

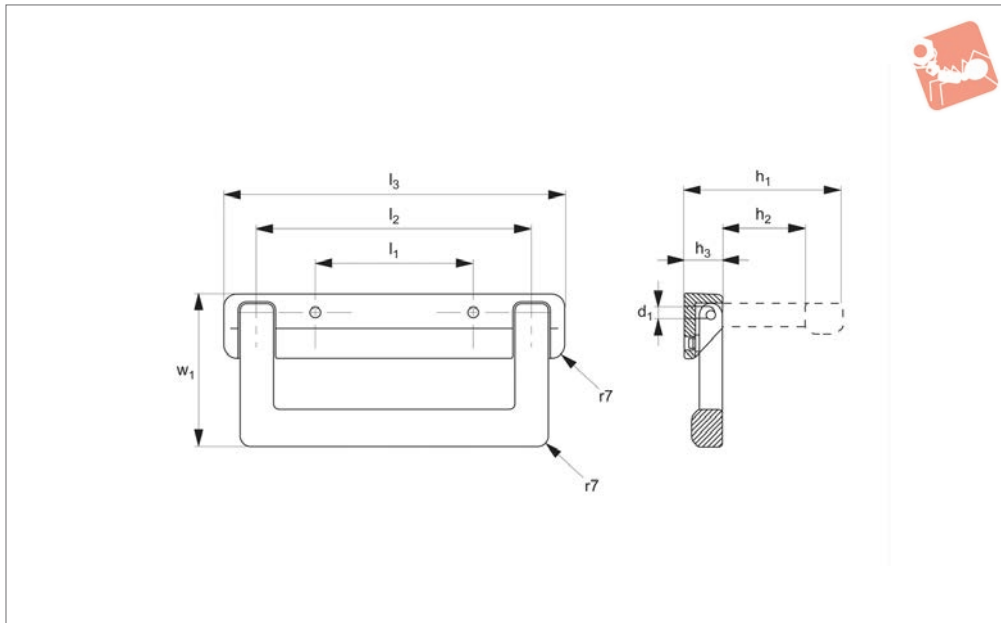

79582

PULL HANDLES

Material

Holder & handle: die-cast aluminium GD-ALSi9Cu3 (alloy 226). Powder coated, half matt in black (similar to RAL 9005) or orange (RAL 2009).

Arbors & restoring springs: stainless steel. Self-acting resilient handle made of aluminium for backside screw mounting.

Technical Notes

Stress resistance: min. 800N. Screw attachment from the front available on request. Other colour combinations available on request.

Order No.	Type	l_1	l_2	l_3	d_1	h_1	h_2	h_3	w_1
79582.W0145	Black	84	145	180	M 6	83	44	20	80
79582.W1145	Orange	84	145	180	M 6	83	44	20	80



79430

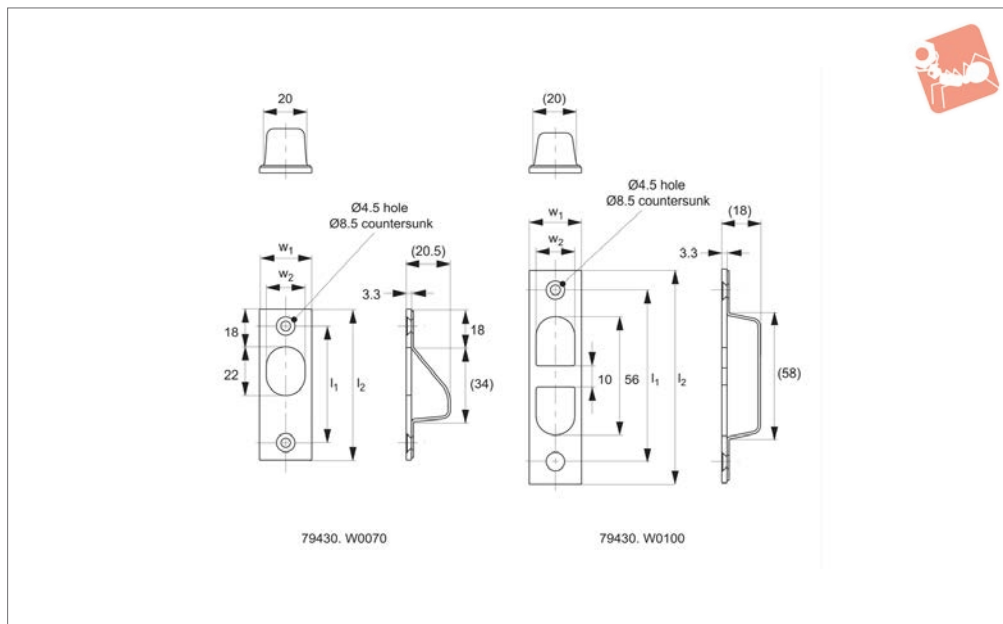

Material

AISI 304 stainless steel, satin finish.

Technical Notes

Compact finger pulls, for doors/enclosures of minimum thickness 30mm.

Order No.	Type	l_1	l_2	w_1	w_2	Weight g
79430.W0070	Type one	54	70	24	18	37
79430.W0100	Type two	80	100	24	18	45

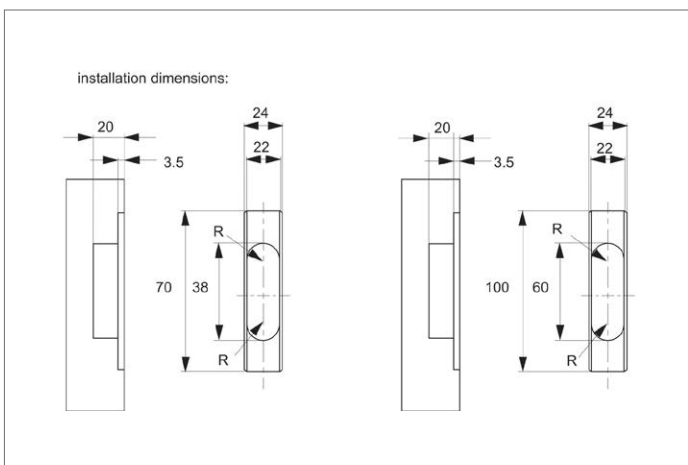

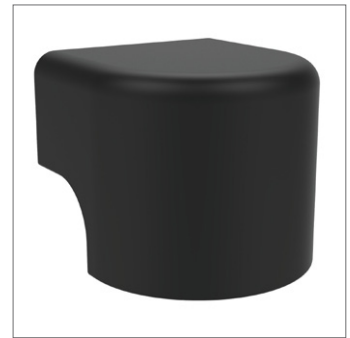
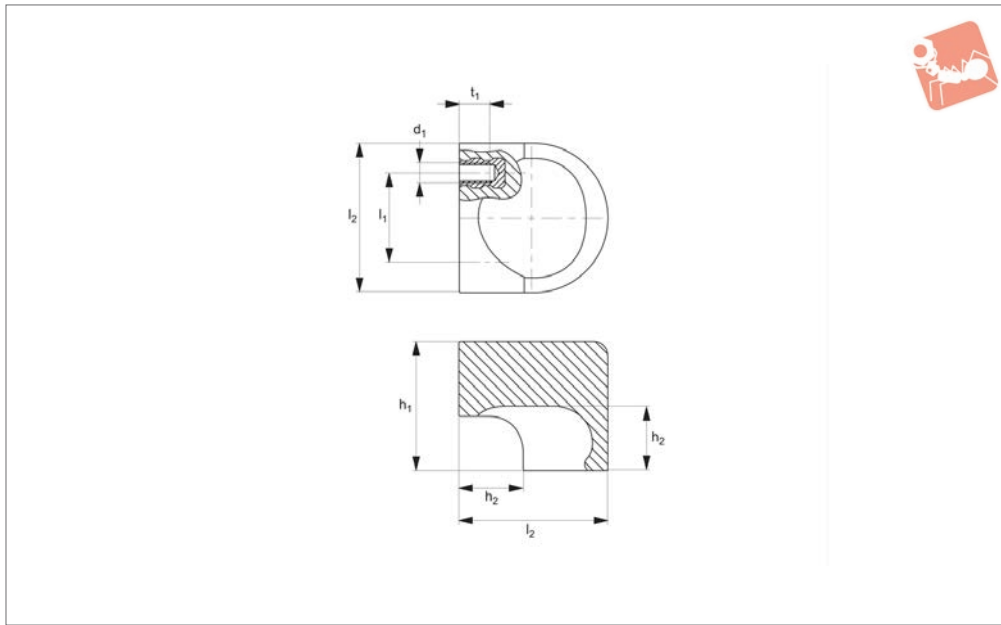

79660

PULL HANDLES

Material

Polyamide PA 6, glass ball reinforced, fine grain semi-matt finish.

Insert: threaded brass bushing.

furniture.

Technical Notes

Ideal finger pull for cabinets, enclosures or

Order No.	Type	l_1	l_2	h_1	h_2	d_1	t_1
79660.W0014	Black	14	26	22	11	M 4	6
79660.W0018	Black	18	30	26	13	M 4	6
79660.W0114	Grey	14	26	22	11	M 4	6
79660.W0118	Grey	18	30	26	13	M 4	6





79820

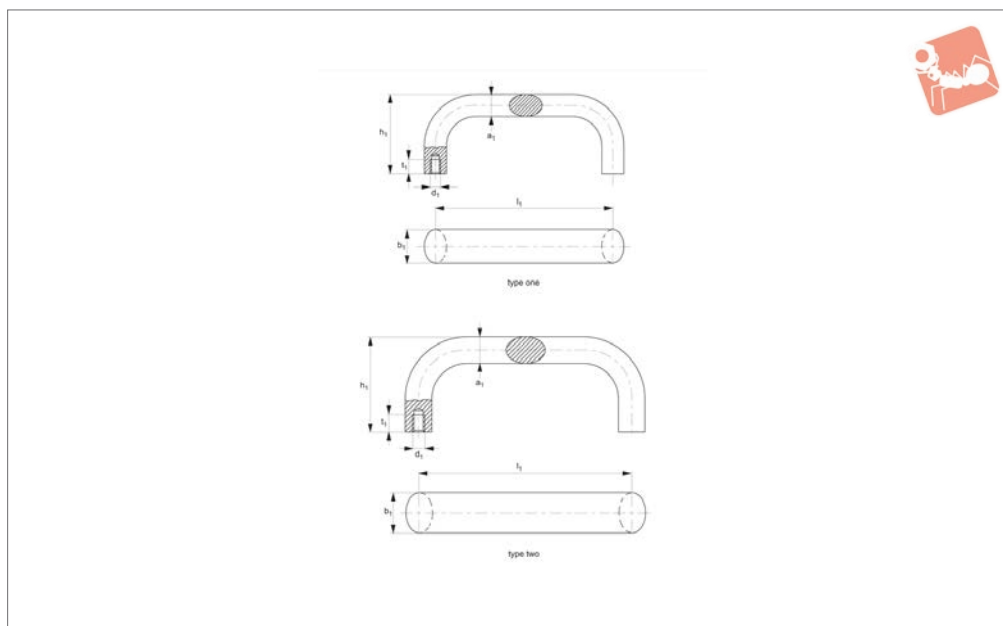

Material

Oval profiled aluminium AlMgSi 0.5. Vibration ground and powder coated in RAL 9002 grey white.

Tips

Especially suited for food and medical industries. Other RAL shades available on request.

Technical Notes

Minimum stress resistance >1000N.

Order No.	Type	l_1	d_1	a_1	b_1	h_1	t_1
79820.W0010	Type One	100	M 6	13	20	50	12
79820.W0013	Type One	128	M 6	13	20	50	12
79820.W0016	Type One	160	M 6	13	20	50	12
79820.W0114	Type Two	140	M 8	17	26	55	14
79820.W0116	Type Two	160	M 8	17	26	55	14
79820.W0118	Type Two	180	M 8	17	26	55	14
79820.W0119	Type Two	192	M 8	17	26	55	14
79820.W0135	Type Two	350	M 8	17	26	55	14



Pull Handles

aluminium, Clean line

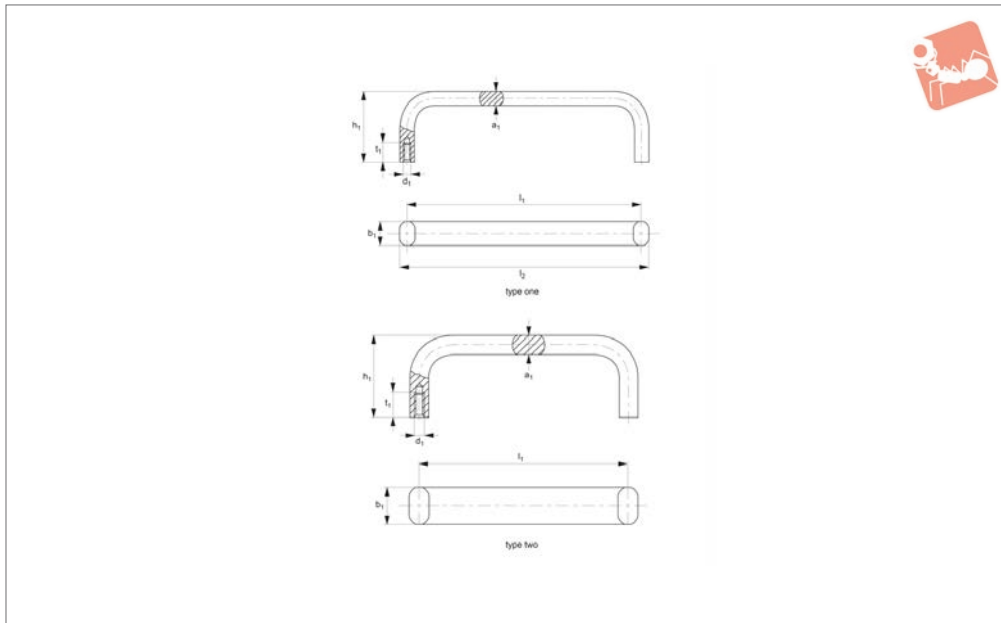

79830

PULL HANDLES

Material

Flat-oval profiled aluminum AlMgSi 0.5.
Vibration ground and powder coated in RAL 9002 grey white.

Tips

Especially suited for food and medical industries. Other RAL shades are available on request.

Technical Notes

Minimum stress resistance 500N.

Order No.	Type	l_1	l_2	d_1	a_1	b_1	h_1	t_1
79830.W0005	Type One	55	63	M 5	8	12	40	10
79830.W0008	Type One	88	96	M 5	8	12	40	10
79830.W0010	Type One	100	108	M 5	8	12	40	10
79830.W0012	Type One	120	128	M 5	8	12	40	10
79830.W0018	Type One	180	188	M 5	8	12	40	10
79830.W0020	Type One	200	208	M 5	8	12	40	10
79830.W0023	Type One	235	243	M 5	8	12	40	10
79830.W0025	Type One	250	258	M 5	8	12	40	10
79830.W0112	Type Two	120	130	M 5	10	20	45	10
79830.W0114	Type Two	140	150	M 5	10	20	45	10
79830.W0118	Type Two	180	190	M 5	10	20	45	10
79830.W0120	Type Two	200	210	M 5	10	20	45	10
79830.W0135	Type Two	350	360	M 6	10	20	45	12



79840

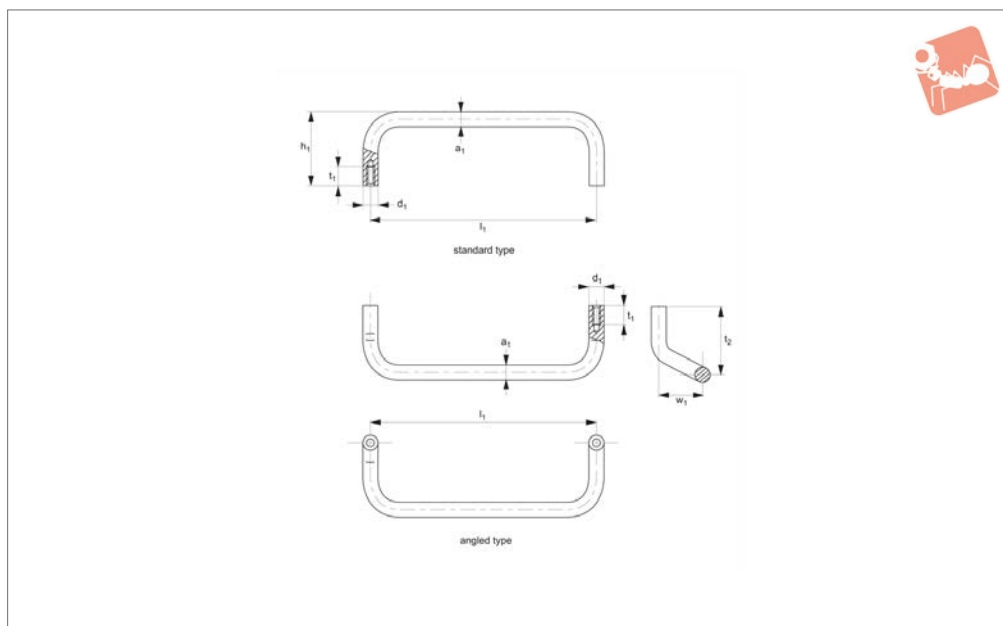

Material

Profile aluminium AlMgSi 0.5. Vibration ground and powder-coated in RAL 9002 grey white.

Technical Notes

Minimum stress resistance 500N.

Tips

Especially suited for food and medical industries.

Order No.	Type	l_1	d_1	a_1	h_1	t_1	t_2	w_1
79840.W0005	Standard	55	M 5	Ø10	40	10	-	-
79840.W0008	Standard	88	M 5	Ø10	40	10	-	-
79840.W0010	Standard	100	M 5	Ø10	40	10	-	-
79840.W0012	Standard	120	M 5	Ø10	40	10	-	-
79840.W0018	Standard	180	M 5	Ø10	40	10	-	-
79840.W0020	Standard	200	M 5	Ø10	40	10	-	-
79840.W0023	Standard	235	M 5	Ø10	40	10	-	-
79840.W0025	Standard	250	M 5	Ø10	40	10	-	-
79840.W0108	Angled	86	M 5	Ø10	-	10	40	30
79840.W0112	Angled	120	M 5	Ø10	-	10	40	30
79840.W0118	Angled	180	M 5	Ø10	-	10	40	30



Pull Handles

aluminium, Clean line

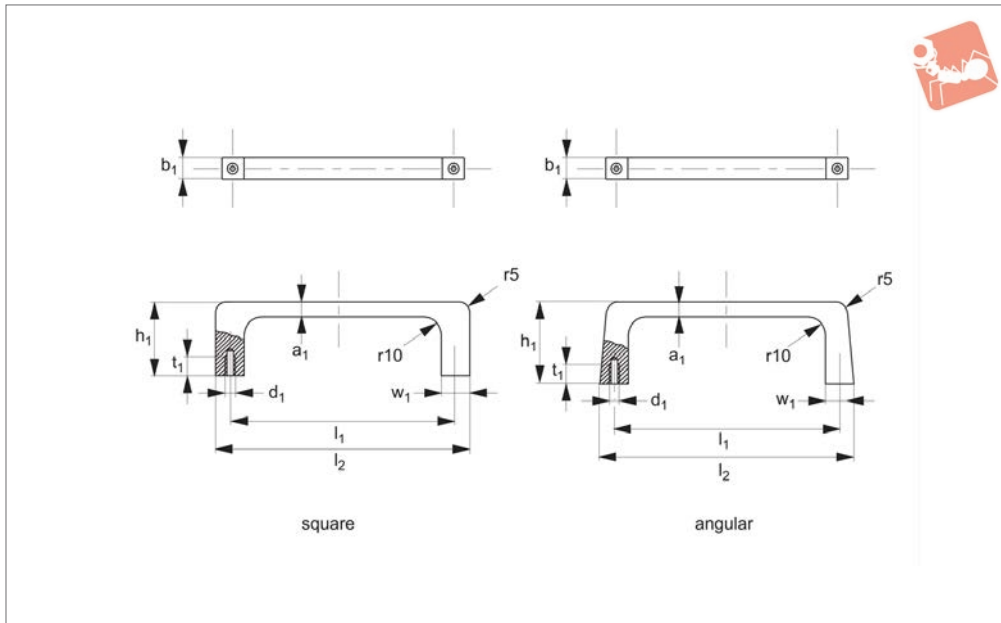

79860

PULL HANDLES

Material

Cut profiled, aluminium AlMgSi 0.5. Vibration ground and powder coated in RAL 9002 grey white.

Tips

Especially suited for food and medical industries. Other RAL shades are available on request.

Technical Notes

Minimum stress resistance 500N.

Order No.	Type	l_1	l_2	d_1	a_1	b_1	h_1	t_1	w_1
79860.W0005	Square	55	67	M 5	8	12	40	10	12
79860.W0008	Square	88	100	M 5	8	12	40	10	12
79860.W0012	Square	120	132	M 5	8	12	40	10	12
79860.W0018	Square	180	192	M 5	8	12	40	10	12
79860.W0023	Square	235	247	M 5	8	12	40	10	12
79860.W0102	Angular	25	40	M 5	8	12	46	10	12
79860.W0105	Angular	55	69	M 5	8	12	46	10	12
79860.W0108	Angular	88	102	M 5	8	12	46	10	12
79860.W0112	Angular	120	134	M 5	8	12	46	10	12
79860.W0118	Angular	180	194	M 5	8	12	46	10	12
79860.W0123	Angular	235	249	M 5	8	12	46	10	12



79880

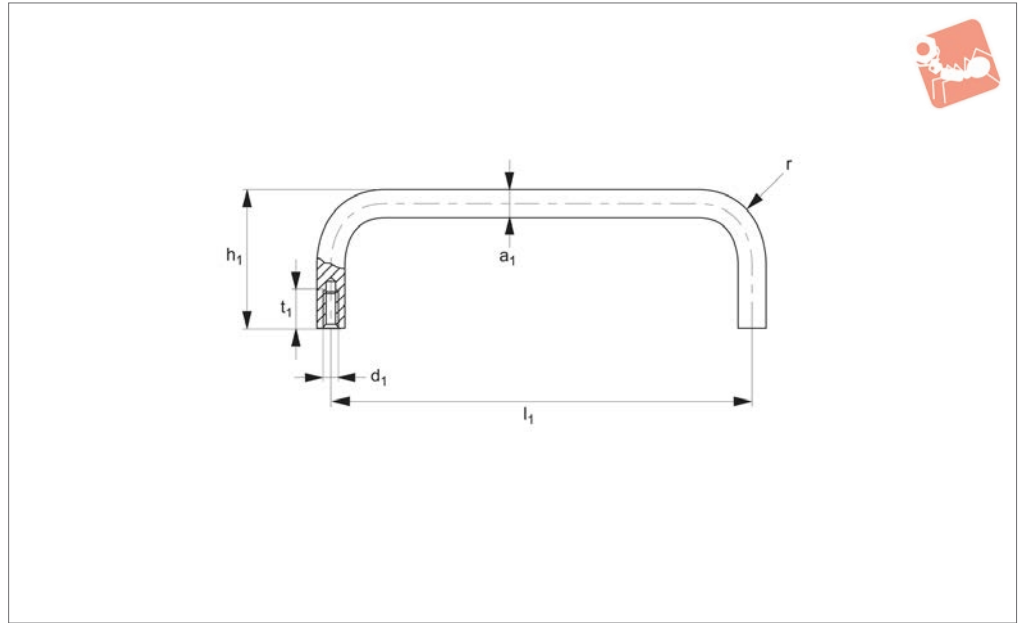

Material

Round bar aluminium AlMgSi 0.5. Vibration ground and powder coated in RAL 9002 grey white.

Tips

Especially suited for food and medical industries. Other RAL shades are available on request.

Technical Notes

Minimum stress resistance >1000N.

Order No.	Type	l_1	d_1	a	h_1	R	t_1
79880.W0120	Standard	200	M 8	20	70	22	15
79880.W0125	Standard	250	M 8	20	70	22	15
79880.W0130	Standard	300	M 8	20	70	22	15
79880.W0135	Standard	350	M 8	20	70	22	15
79880.W0140	Standard	400	M 8	20	70	22	15
79880.W0160	Standard	600	M 8	20	70	22	15
79880.W0220	Standard	200	M 8	25	85	28	15
79880.W0225	Standard	250	M 8	25	85	28	15
79880.W0230	Standard	300	M 8	25	85	28	15
79880.W0240	Standard	400	M 8	25	85	28	15
79880.W0260	Standard	600	M 8	25	85	28	15
79880.W0330	Standard	300	M10	30	100	34	15
79880.W0340	Standard	400	M10	30	100	34	15
79880.W0360	Standard	600	M10	30	100	34	15



Pull Handles Bow Type

aluminium, Clean line

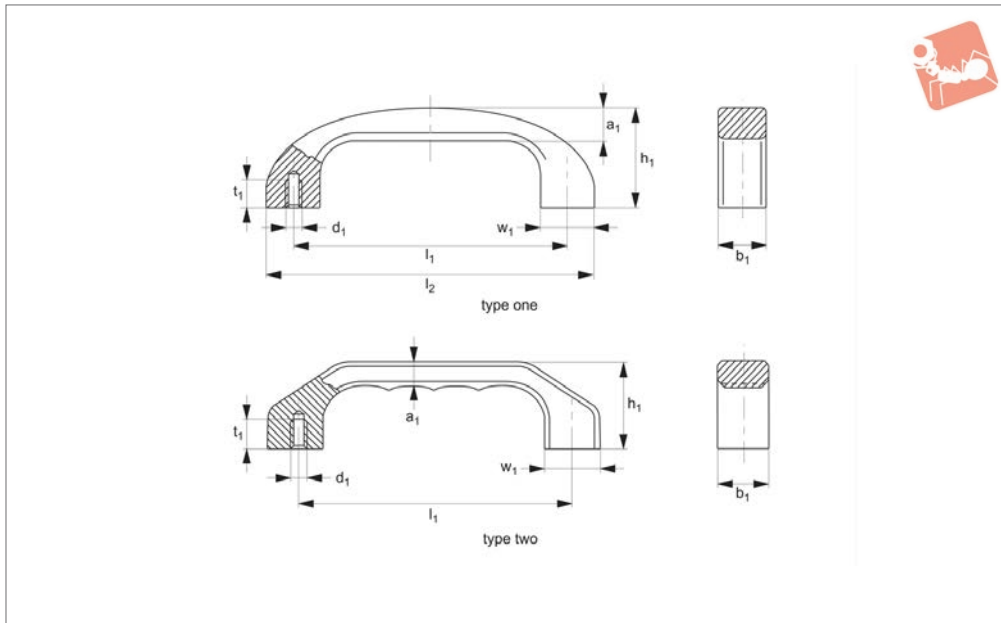

79900

PULL HANDLES

Material

Solid aluminium handles in a modern industrial design. Aluminium section ALMgSi 0.5. Vibration ground and powder coated in RAL 9002 grey white.

Technical Notes

Minimum stress resistance >1000N.

Tips

Especially suited for food and medical

industries. Other RAL shades available on request.

Order No.	Type	l_1	l_2	d_1	a_1	b_1	h_1	t_1	w_1
79900.W0120	Type One	120	144	M 6	15.0	22	46	12	24
79900.W0140	Type One	140	168	M 8	17.0	25	53	15	28
79900.W0520	Type Two	120	-	M 6	10.5	22	39	12	24
79900.W0540	Type Two	140	-	M 8	12.0	25	45	15	28
79900.W0560	Type Two	160	-	M 8	13.5	28	52	15	32



79920

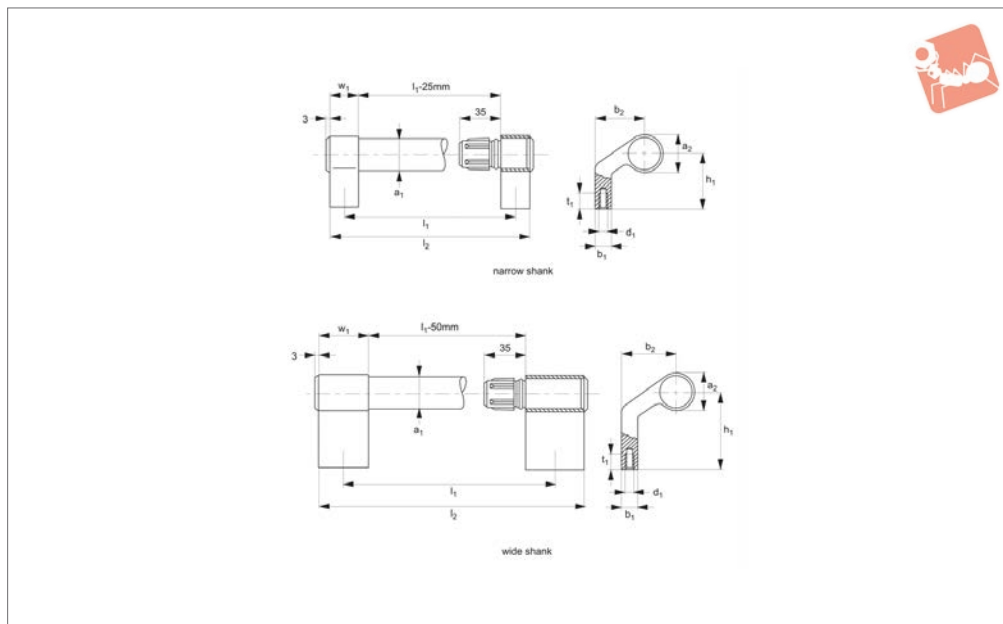

Material

Handle shank: extruded aluminium ALMg Si 0,5, powder coated to RAL9002, grey white.

Handle tube: extruded aluminium, ALMg Si 0,5, Ø30x1,5mm, powder coated to RAL9002, grey white.

Shank insert: polyamide PA 6, glass ball reinforced in similar colour shade.

Technical Notes

Torsionally stiff and splash-proof seat; edges rounded by vibratory grinding. Minimum stress resistance >1000N.

Tips

Especially suited for food and medical industries. All handle lengths and RAL shades are available on request.

Order No.	Type	l_1	l_2	d_1	a_1	a_2	b_1	b_2	h_1	w_1
79920.W0020	Narrow Shank	200	250	M 8	Ø30 x 1,5	33	15	45	50	25
79920.W0025	Narrow Shank	250	300	M 8	Ø30 x 1,5	33	15	45	50	25
79920.W0030	Narrow Shank	300	350	M 8	Ø30 x 1,5	33	15	45	50	25
79920.W0035	Narrow Shank	350	400	M 8	Ø30 x 1,5	33	15	45	50	25
79920.W0040	Narrow Shank	400	450	M 8	Ø30 x 1,5	33	15	45	50	25
79920.W0050	Narrow Shank	500	550	M 8	Ø30 x 1,5	33	15	45	50	25
79920.W0060	Narrow Shank	600	650	M 8	Ø30 x 1,5	33	15	45	50	25
79920.W0120	Wide Shank	200	250	M 8	Ø30 x 1,5	33	15	55	70	50
79920.W0125	Wide Shank	250	300	M 8	Ø30 x 1,5	33	15	55	70	50
79920.W0130	Wide Shank	300	350	M 8	Ø30 x 1,5	33	15	55	70	50
79920.W0135	Wide Shank	350	400	M 8	Ø30 x 1,5	33	15	55	70	50
79920.W0140	Wide Shank	400	450	M 8	Ø30 x 1,5	33	15	55	70	50
79920.W0150	Wide Shank	500	550	M 8	Ø30 x 1,5	33	15	55	70	50
79920.W0160	Wide Shank	600	650	M 8	Ø30 x 1,5	33	15	55	70	50



Tube Pull Handles

Clean line

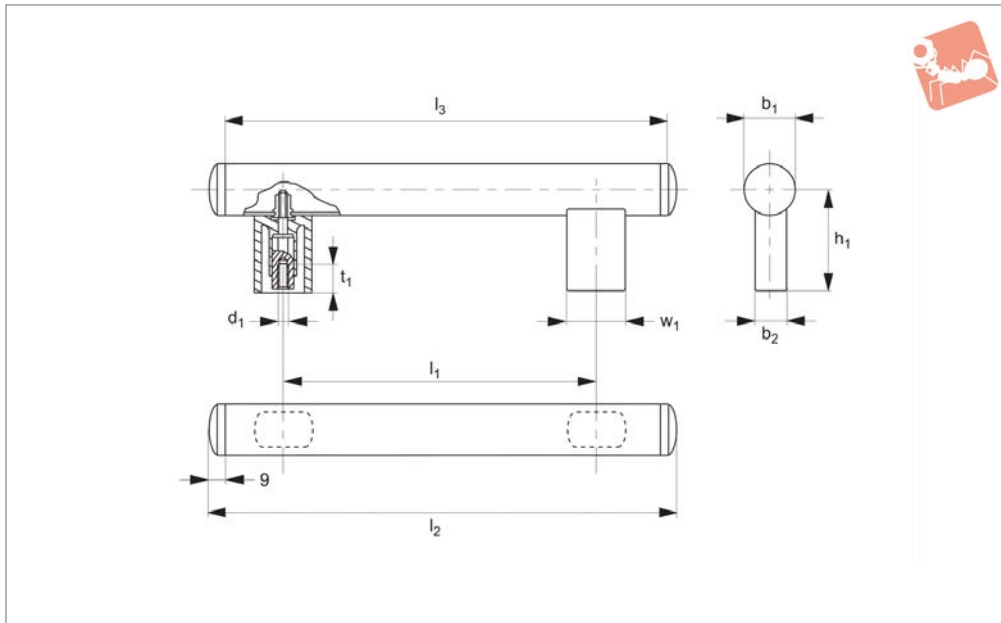

79930

PULL HANDLES

Material

Handle shank: polyamide (PA 6), glass bead reinforced, semi-gloss in RAL9002 grey white.

Handle tube: aluminium section, ALMgSi 0,5, Ø30x1,5mm, powered coated in RAL9002 grey white.

Tube holder and tube cap: polyamide PA6 glass ball reinforced in similar RAL colour shade.

Technical Notes

Non detachable blind rivet nuts ensure that the handle tube cannot be torn out of

its connection to the shank. Minimum stress resistance 800N.

Tips

Especially suited for food and medical industries. All handle lengths and RAL shades are available on request.

Order No.	l_1	l_2	l_3	d_1	b_1	b_2	h_1	t_1	w_1
79930.W0200	200	288	270	M 6	30 x 1,5	20	60	17	34
79930.W0250	250	338	320	M 6	30 x 1,5	20	60	17	34
79930.W0300	300	388	300	M 6	30 x 1,5	20	60	17	34
79930.W0350	350	438	420	M 6	30 x 1,5	20	60	17	34
79930.W0400	400	488	470	M 6	30 x 1,5	20	60	17	34
79930.W0500	500	588	570	M 6	30 x 1,5	20	60	17	34
79930.W0600	600	688	670	M 6	30 x 1,5	20	60	17	34



79960

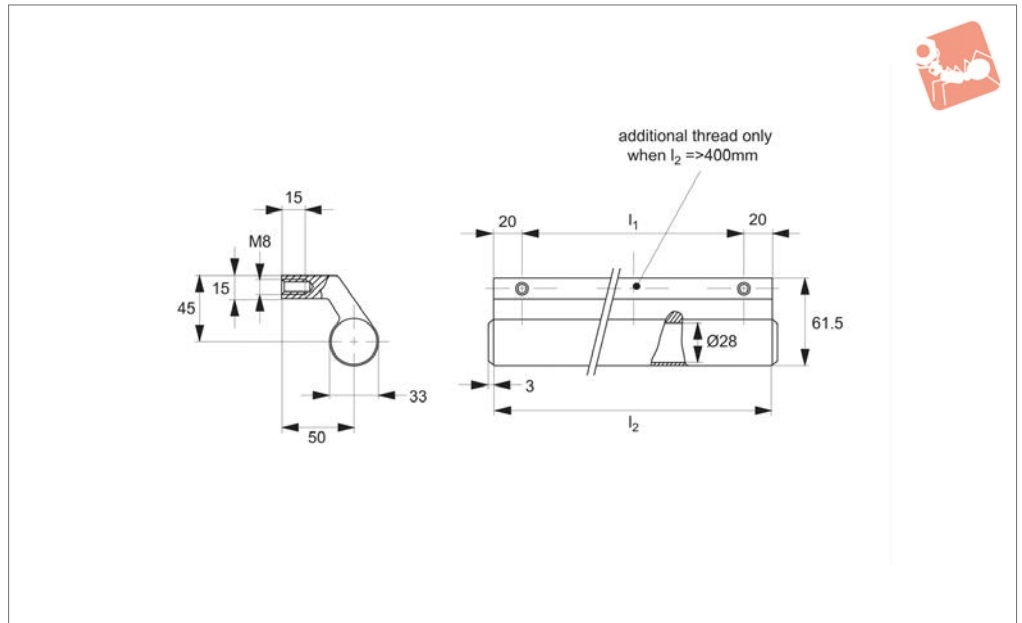

Material

Aluminium section AlMgSi 0.5 powder coated in RAL 9002 grey white. Cover caps made of polyamide PA 6, glass-bead reinforced in similar colour shade.

Technical Notes

Minimum stress resistance >1000N.

Tips

Handles in a special heavy-duty design. All

handle lengths and RAL shades available on request.

Order No.	l_1	l_2
79960.W0110	110	150
79960.W0160	160	200
79960.W0210	210	250
79960.W0260	260	300
79960.W0310	310	350
79960.W0360	360	400
79960.W0460	460	500
79960.W0560	560	600

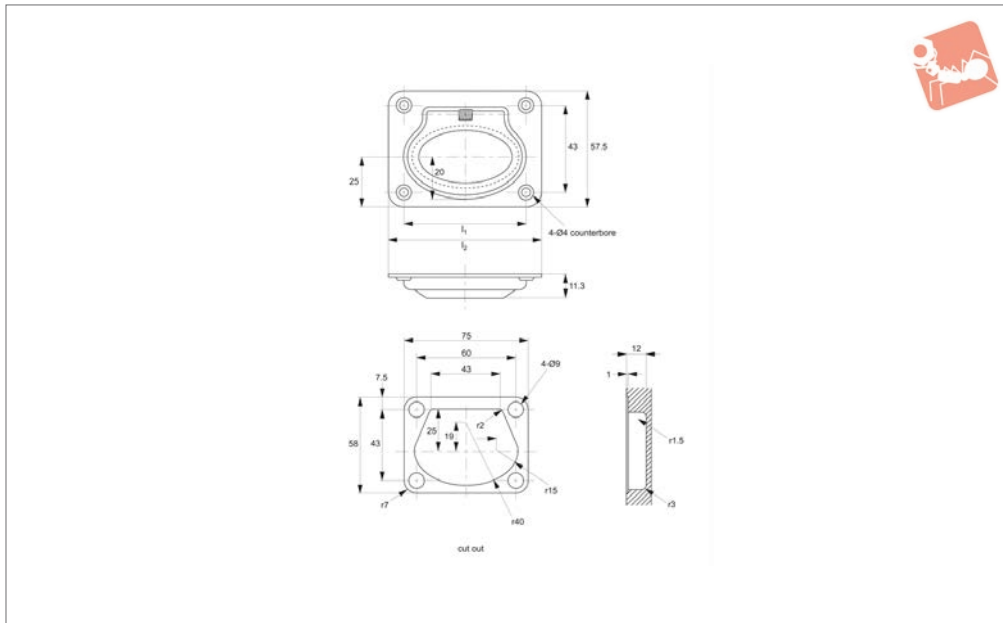

79711

PULL HANDLES

Material

AISI 304 stainless steel, polished.

Technical Notes

Supplied with stainless steel screws (3.8x16).

Order No.	l_1	l_2	Weight g
79711.W0110	60	75	51

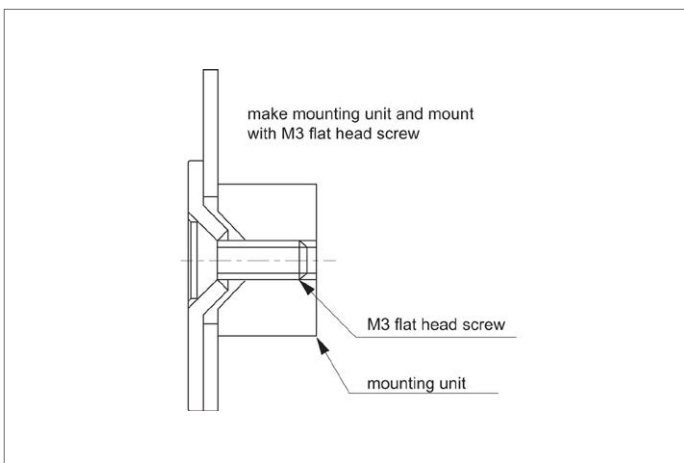



79720

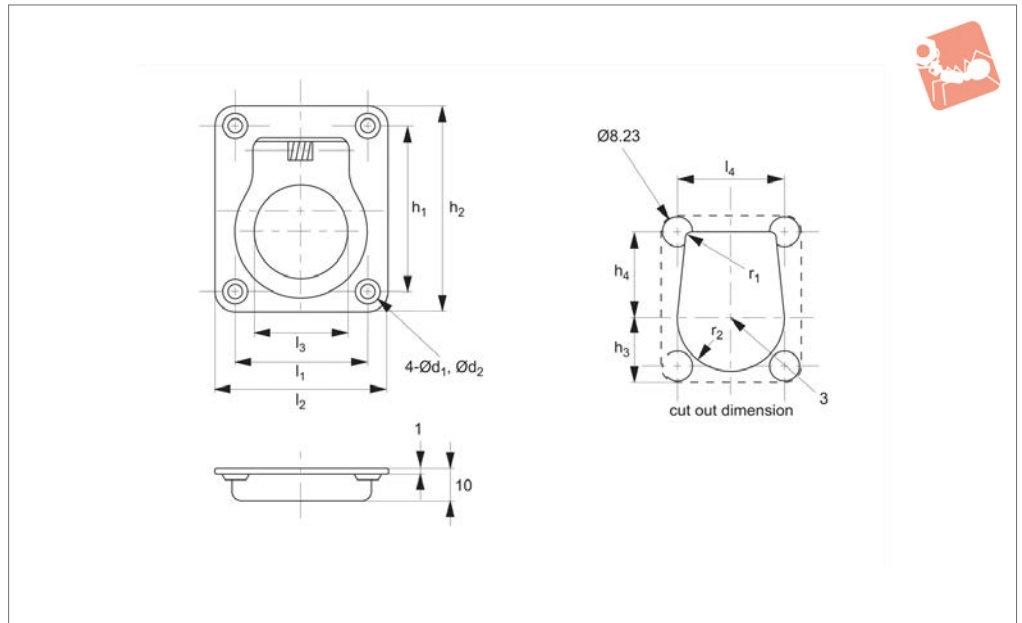

Material

AISI 304 stainless steel, polished.

Technical Notes

Supplied with stainless steel screws.

Order No.	l_1	d_1	d_2	h_1	h_2	h_3	h_4	l_2	l_3	l_4	r_1	$\varnothing r_2$	Weight g
79720.W0010	28	4.0	6.2	34	44	19	19.5	38	18	24.5	14.2	31	21
79720.W0020	35	4.4	7.0	45	60	25	25.0	50	27	25.0	19.5	41	36

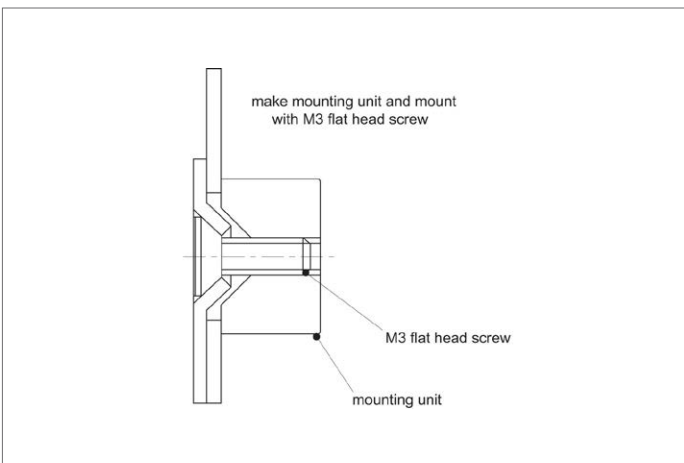



Ring Pulls, Recessed

stainless steel

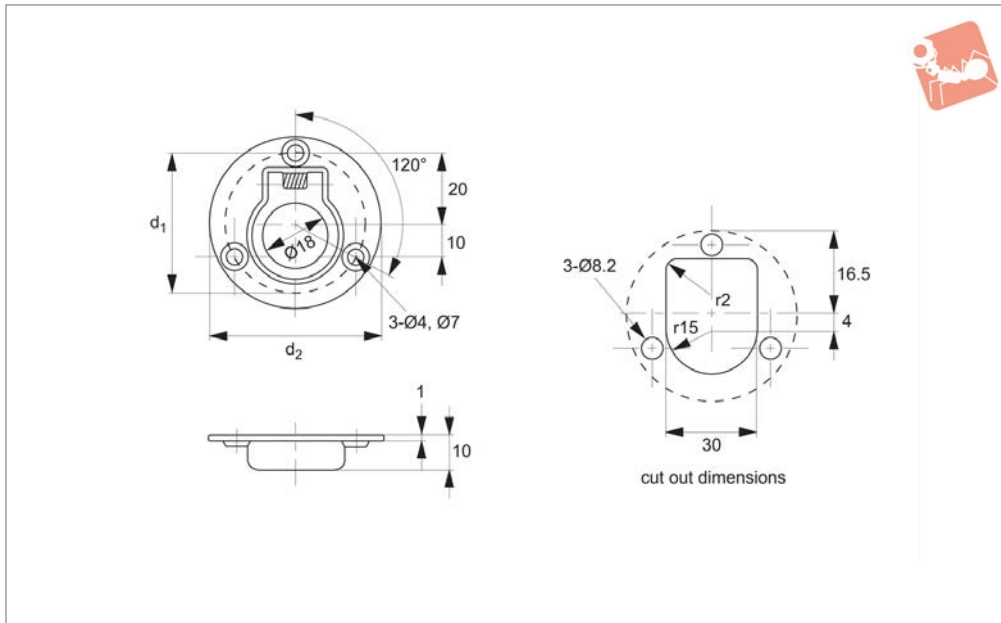

79730

PULL HANDLES

Material

AISI 304 stainless steel, polished.

Technical Notes

Supplied with stainless steel screws (3.8x16).

Order No.	d_1	d_2	Weight g
79730.W0010	40	50	23

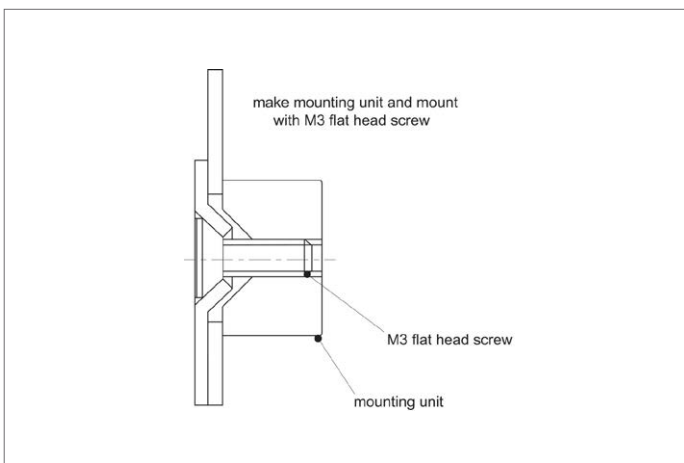



79740

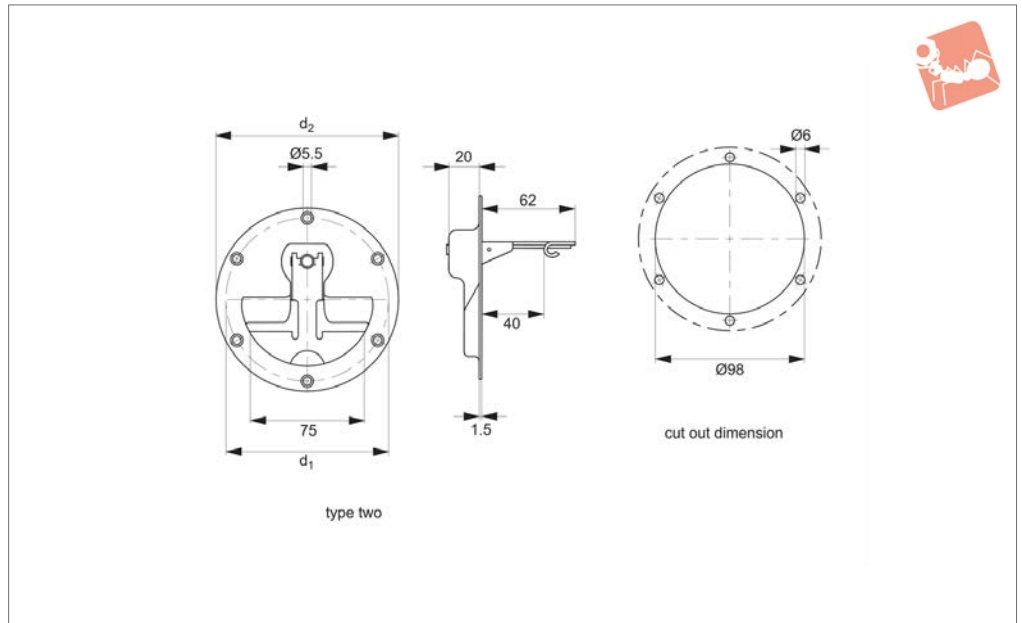

Material

AISI 304 stainless steel, polished.

returns the handle to its resting position when released.

Technical Notes

Incorporates a pull-back spring which

Order No.	Type	d_1	d_2
79740.W0120	Type Two	107	120

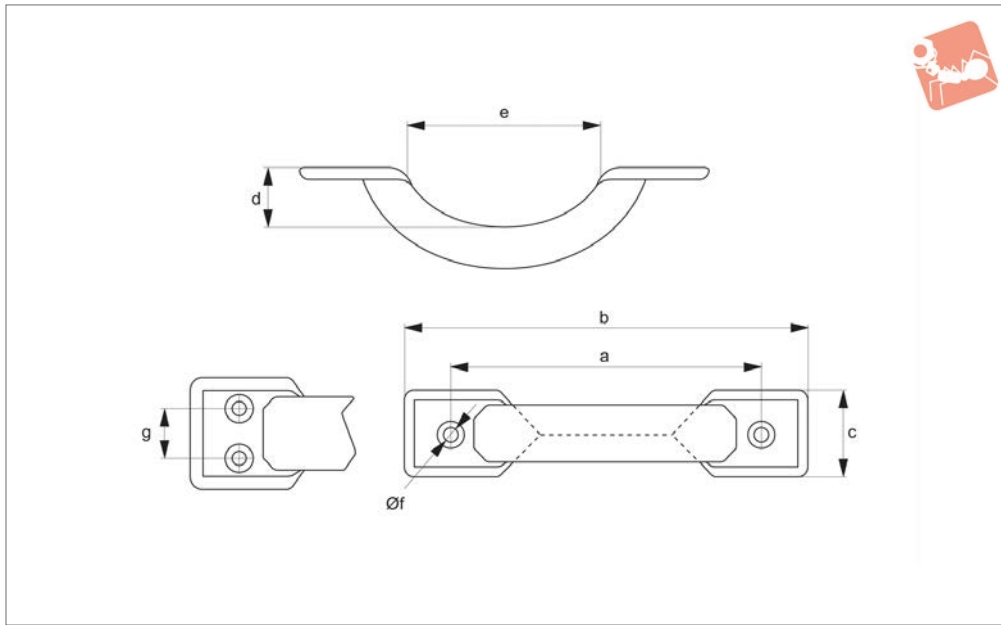

79583

PULL HANDLES

Material

Steel, nickel plated.

Order No.	Finish	a	b	c	d	e	g	Ø f	Weight g
79583.W0001	Nickel Plated Steel	66	80	18.5	13	38	-	3.2	20
79583.W0101	Nickel Plated Steel	83	100	21.5	13	48	-	3.2	20
79583.W0121	Nickel Plated Steel	99	120	24.5	16	60	-	3.2	20
79583.W0141	Nickel Plated Steel	121	140	28.5	19	70	13	3.2	20
79583.W0161	Nickel Plated Steel	140	160	29.5	24	80	13	3.2	20



PULL HANDLES



79584

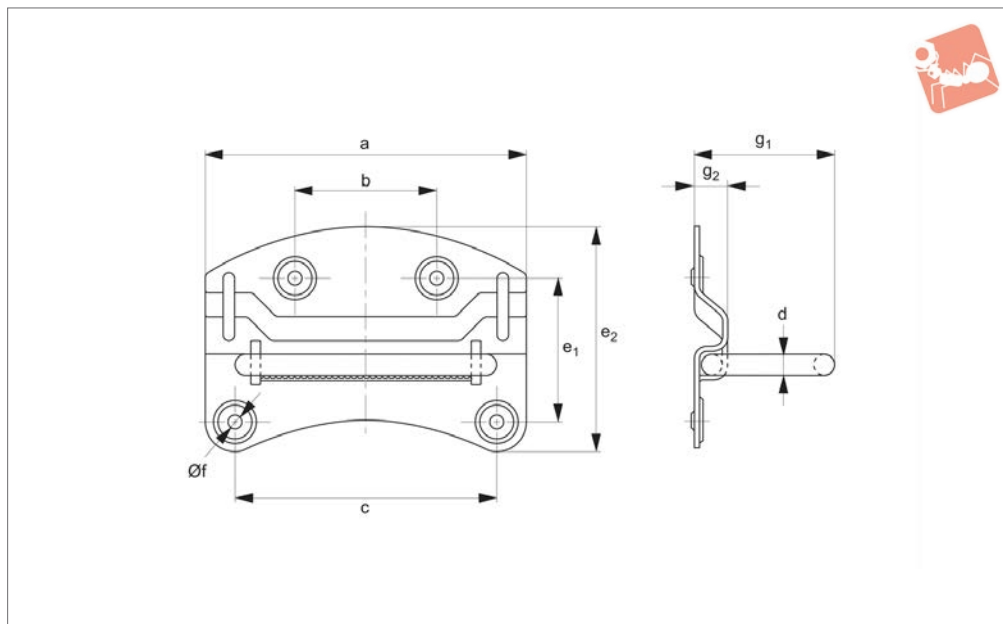

Material

Steel, brass or zinc plated.

Order No.	Finish	a	b	c	d	e ₁	e ₂	g ₁	g ₂	Ø f	Weight g
79584.W0002	Brass Plated Steel	90	42	72	6.5	40	67	40	9	4.2	90
79584.W0112	Brass Plated Steel	110	57	84	6.5	48	84	55	13	4.5	90
79584.W0004	Zinc Plated Steel	90	42	72	6.5	40	67	40	9	4.2	90
79584.W0114	Zinc Plated Steel	110	57	84	6.5	48	84	55	13	4.5	90

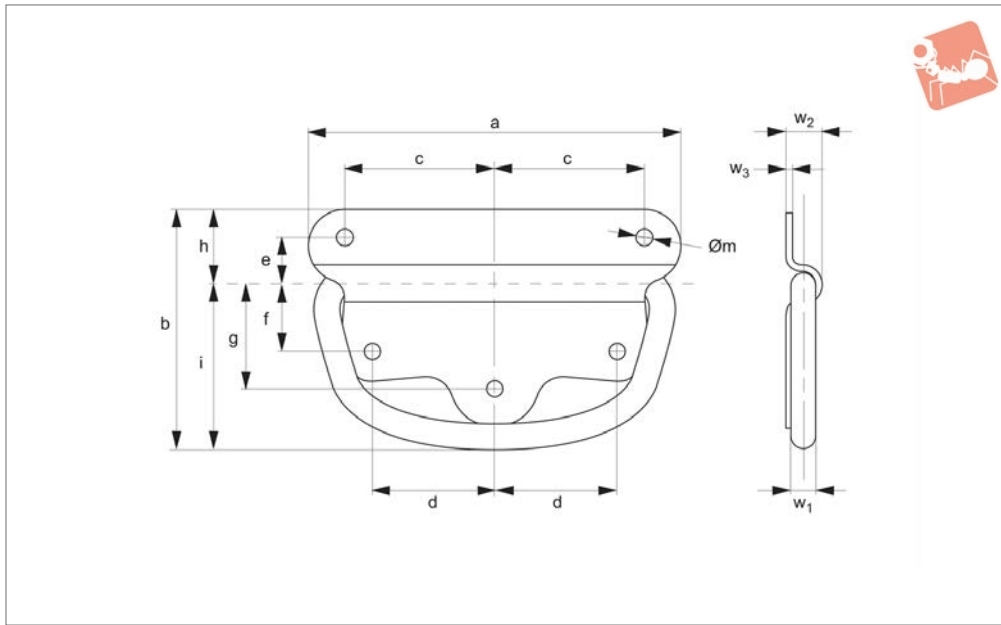

79585

PULL HANDLES

Material

Steel, brass or zinc plated.

Order No.	Finish	a	b	c	d	e	f	g	Ø m	h	i	w ₁	w ₂	w ₃	Weight g
79585.W0008	Brass	80	56.0	33.0	27.0	11	13	20	4.0	18	38.0	6.0	9	1	90
79585.W0009	Brass	90	61.0	37.5	30.0	11	20	28	4.4	17	44.0	6.5	9	1	90
79585.W0010	Brass	100	62.5	40.0	32.5	12	18	28	4.4	19	43.5	6.5	9	1	90
79585.W0011	Brass	110	66.5	45.0	37.5	13	25	37	5.0	19	47.5	7.0	9	1	90
79585.W0408	Zinc	80	56.0	33.0	27.0	11	13	20	4.0	18	38.0	6.0	9	1	90
79585.W0409	Zinc	90	61.0	37.5	30.0	11	20	28	4.4	17	44.0	6.5	9	1	90
79585.W0410	Zinc	100	62.5	40.0	32.5	12	18	28	4.4	19	43.5	6.5	9	1	90
79585.W0411	Zinc	110	66.5	45.0	37.5	13	25	37	5.0	19	47.5	7.0	9	1	90



PULL HANDLES



79586

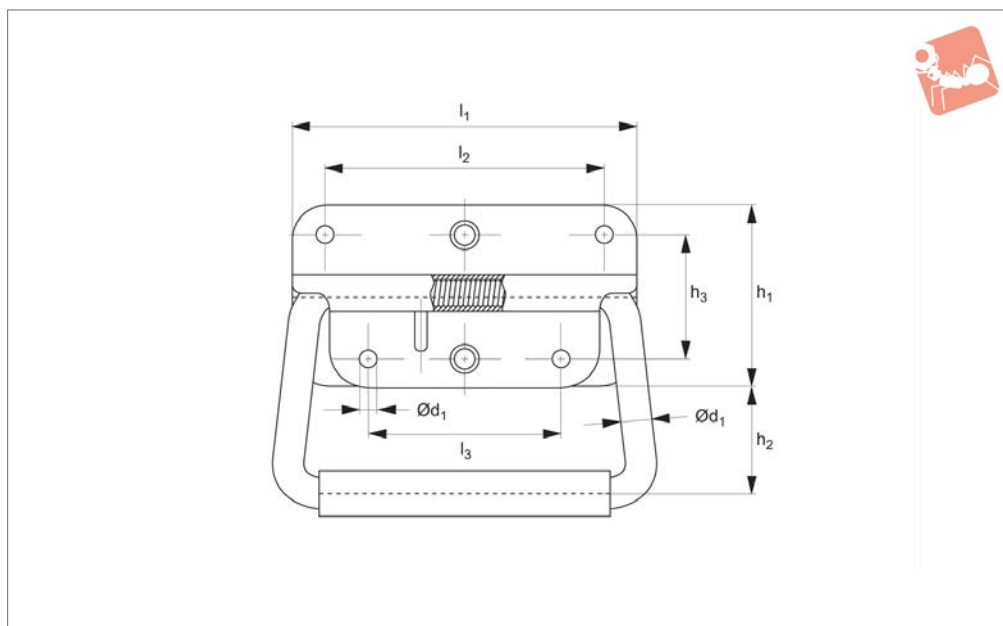

Material

Steel, zinc plated.

Order No.	Finish	Length available	$\varnothing d_1$	$\varnothing d_2$	h_1	h_2	h_3	l_1	l_2	l_3	Weight g
79586.W0004	Zinc plated steel	100mm	8	5.2	54	30	36.5	103	82.5	57	120

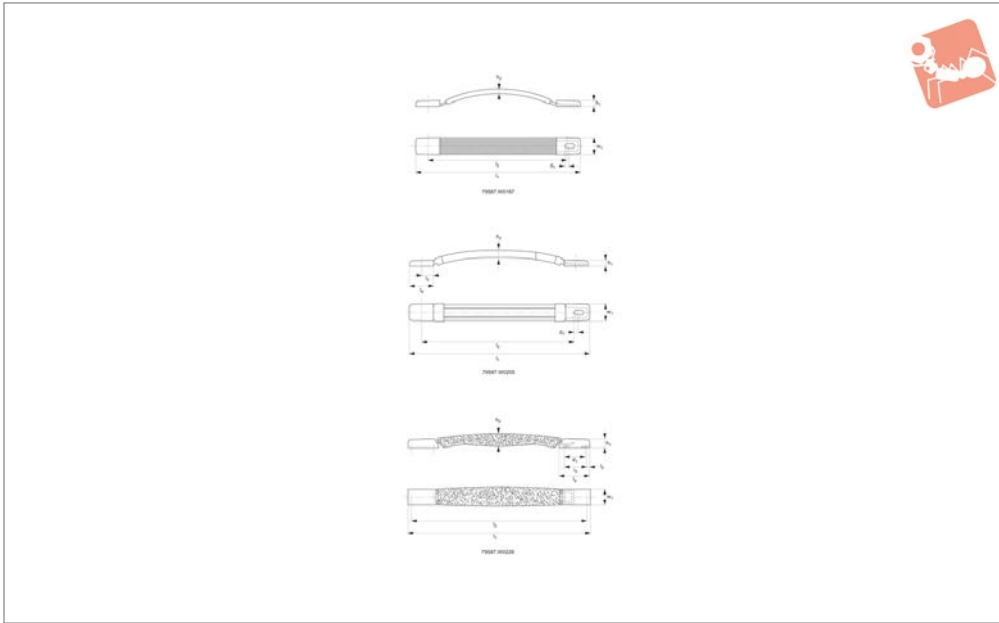

79587

PULL HANDLES

Material

Black handles of soft plastic, 49620.W0187 & 49620.W0205 with steel spring inside.

Nickel plated steel cover caps.

tions.

Technical Notes

For instruments, cases and similar applica-

Order No.	d_1	h_1	h_2	l_1	l_2	w_1	Stress resistance N
79587.W0187	4.5	8.6	8.0	223	187	23.3	300



PULL HANDLES



79588

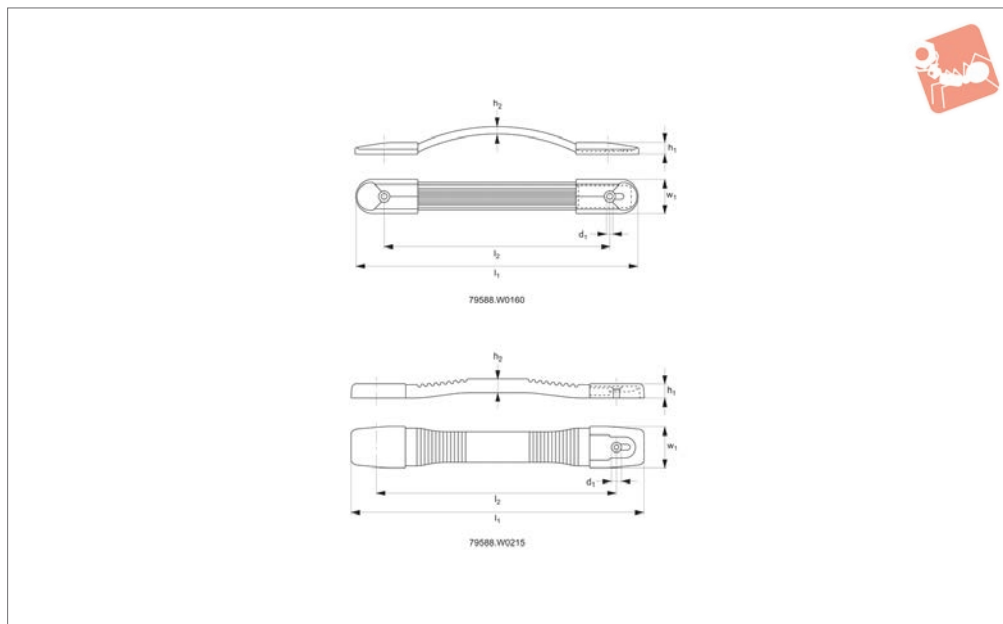

Material

Handles made of black soft plastic with a steel spring inside and black plastic cover

caps. For front mounting with countersunk screws (not included in delivery).

Order No.	d_1	h_1	h_2	l_1	l_2	w_1	Stress resistance N
79588.W0215	5.3	13	12	268	215	37	400
79588.W0160	4.3	8.5	5	203	160	25	400

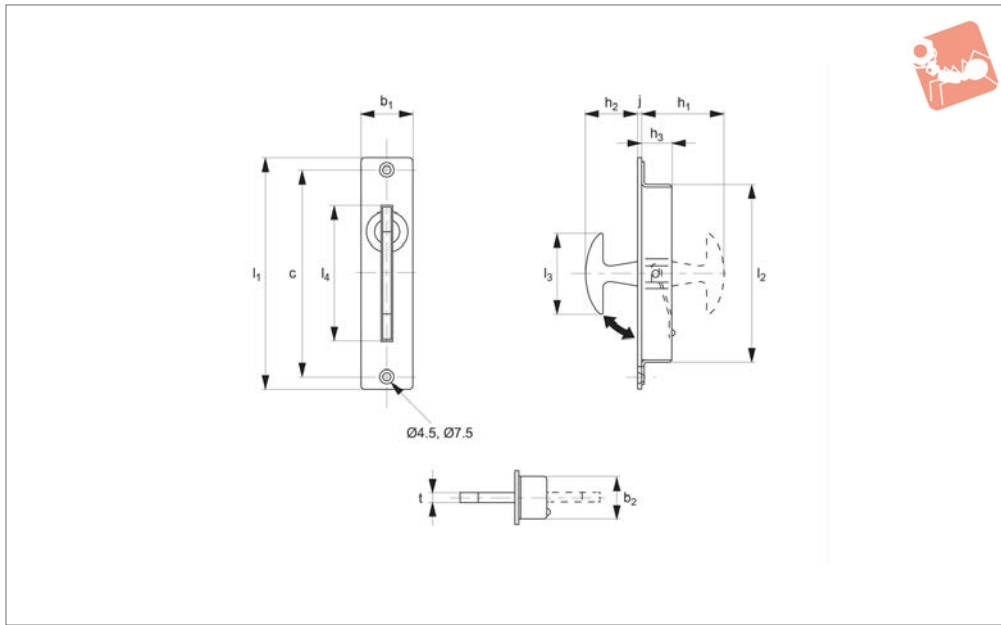

79690

PULL HANDLES

Material

AISI 304 stainless steel, satin finish.

Technical Notes

Supplied with stainless steel screws.

Important Notes

T-handle design. Handle is concealed when not in use.

Order No.	l_1	l_2	l_3	l_4	h_1	h_2	h_3	j	b_1	b_2	t	c	Weight g
79690.W0090	90	66.2	30.2	57	35.5	23.2	10.5	2.2	22	18.5	3.8	80	68
79690.W0115	115	86.2	40.0	67	42.0	26.0	13.0	2.5	25	20.0	4.0	102	102



79700

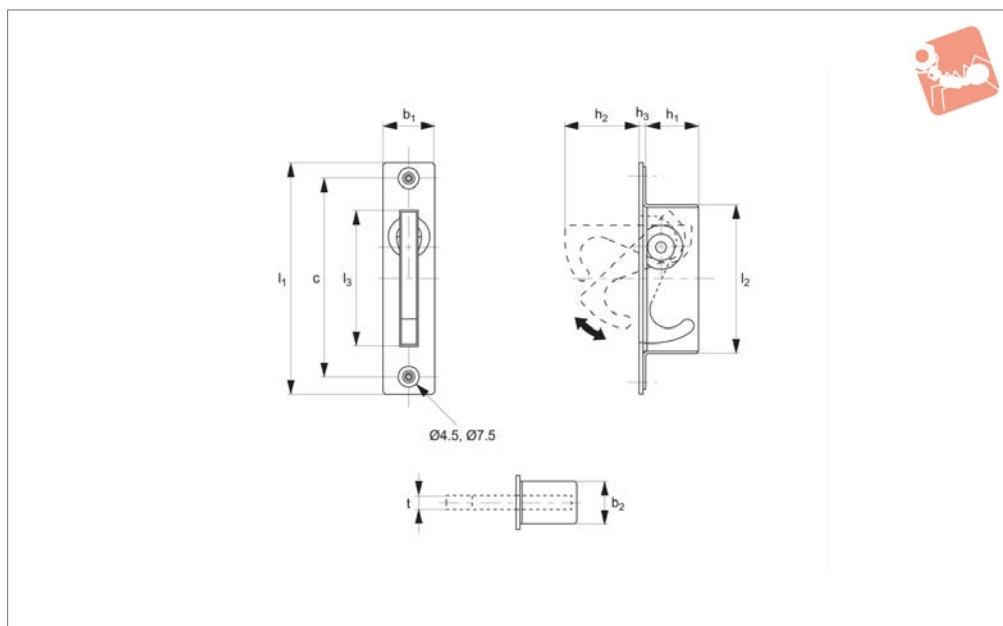

Material

AISI 304 stainless steel, satin finish.

Technical Notes

Supplied with stainless steel screws.

Important Notes

Hook design. Handle is concealed when not in use.

Order No.	l_1	l_2	l_3	h_1	h_2	h_3	b_1	b_2	t	c	Weight g
79700.W0080	80	50	44	18	25	2	18	15	5	68	48
79700.W0100	100	63	54	21	32	2	20	15	5	85	66

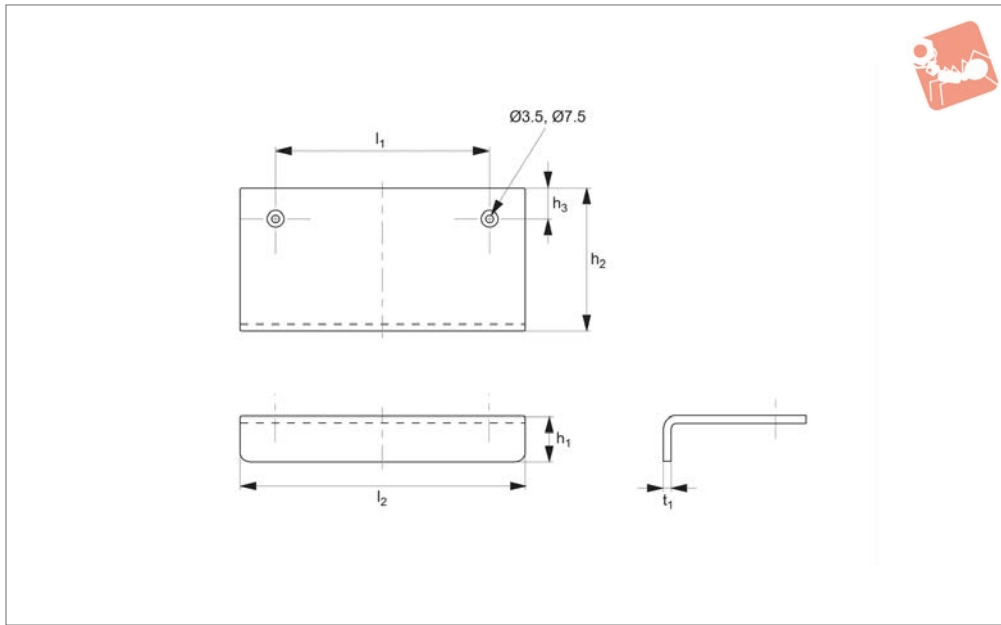

79590

PULL HANDLES

Material

AISI 304 stainless steel, mirror finish.

Technical Notes

Supplied with stainless steel screws (3.5x20).

Order No.	l_2	h_1	h_2	h_3	l_1	t_1	Weight g
79590.W0050	50	17	38	8	30	2.5	47
79590.W0070	70	17	38	8	46	2.5	65
79590.W0095	95	18	38	8	65	2.5	90

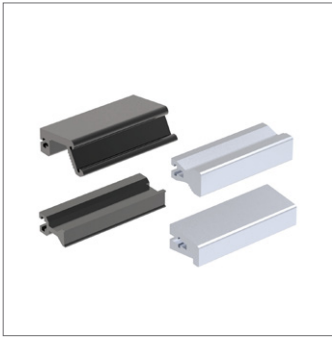

79600

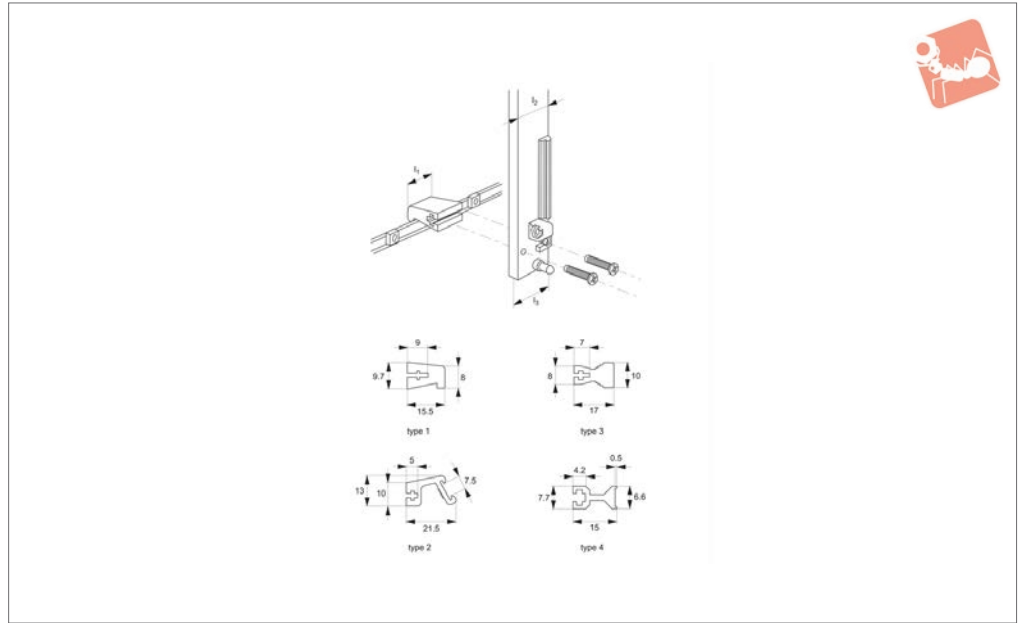

Material

Profiled aluminium AlMgSi 0,5. Vibration ground and anodised, matt finish.

Technical Notes

All panel handles have a cross slot to suit

either M2,5 screw heads (DIN 933) or nuts DIN 935/562 or 934. TE = unit of grid division (grid scale 5,08mm)

R = TE x 5,08mm. B is approx. R - 0,3mm. L is approx. R - 0,6mm.

Order No.	Type	Colour	l_2	l_1	l_3	Te
79600.W0114-1	One	Natural	15	14.6	15.2	3
79600.W0114-4	One	Black	15	14.6	15.2	3
79600.W0119-1	One	Natural	20.1	19.7	20.3	4
79600.W0119-4	One	Black	20.1	19.7	20.3	4
79600.W0124-1	One	Natural	25.1	24.8	25.4	5
79600.W0124-4	One	Black	25.1	24.8	25.4	5
79600.W0129-1	One	Natural	30.2	29.9	30.5	6
79600.W0129-4	One	Black	30.2	29.9	30.5	6
79600.W0140-1	One	Natural	40.4	40.0	40.6	8
79600.W0140-4	One	Black	40.4	40	40.6	8
79600.W0160-1	One	Natural	60.4	60.3	60.7	12
79600.W0160-4	One	Black	60.4	60.3	60.7	12
79600.W0170-1	One	Natural	70.9	70.5	71.1	14
79600.W0170-4	One	Black	70.9	70.5	71.1	14
79600.W0199-1	One	Natural	101.3	101.0	101.6	20
79600.W0199-4	One	Black	101.3	101.0	101.6	20
79600.W0214-1	Two	Natural	15	14.6	15.2	3
79600.W0214-4	Two	Black	15	14.6	15.2	3
79600.W0219-1	Two	Natural	20.1	19.7	20.3	4
79600.W0219-4	Two	Black	20.1	19.7	20.3	4
79600.W0224-1	Two	Natural	25.1	24.8	25.4	5
79600.W0224-4	Two	Black	25.1	24.8	25.4	5
79600.W0229-1	Two	Natural	30.2	29.9	30.5	6
79600.W0229-4	Two	Black	30.2	29.9	30.5	6
79600.W0240-1	Two	Natural	40.4	40.0	40.6	8
79600.W0240-4	Two	Black	40.4	40	40.6	8
79600.W0260-1	Two	Natural	60.4	60.3	60.7	12
79600.W0260-4	Two	Black	60.4	60.3	60.7	12
79600.W0270-1	Two	Natural	70.9	70.5	71.1	14
79600.W0270-4	Two	Black	70.9	70.5	71.1	14
79600.W0299-1	Two	Natural	101.3	101.0	101.6	20
79600.W0299-4	Two	Black	101.3	101.0	101.6	20
79600.W0314-1	Three	Natural	15	14.6	15.2	3



Panel Handles

aluminium



Order No.	Type	Colour	l_2	l_1	l_3	T_e
79600.W0314-4	Three	Black	15	14.6	15.2	3
79600.W0319-1	Three	Natural	20.1	19.7	20.3	4
79600.W0319-4	Three	Black	20.1	19.7	20.3	4
79600.W0324-1	Three	Natural	25.1	24.8	25.4	5
79600.W0324-4	Three	Black	25.1	24.8	25.4	5
79600.W0329-1	Three	Natural	30.2	29.9	30.5	6
79600.W0329-4	Three	Black	30.2	29.9	30.5	6
79600.W0340-1	Three	Natural	40.4	40.0	40.6	8
79600.W0340-4	Three	Black	40.4	40	40.6	8
79600.W0360-1	Three	Natural	60.4	60.3	60.7	12
79600.W0360-4	Three	Black	60.4	60.3	60.7	12
79600.W0370-1	Three	Natural	70.9	70.5	71.1	14
79600.W0370-4	Three	Black	70.9	70.5	71.1	14
79600.W0399-1	Three	Natural	101.3	101.0	101.6	20
79600.W0399-4	Three	Black	101.3	101.0	101.6	20
79600.W0414-1	Four	Natural	15	14.6	15.2	3
79600.W0414-4	Four	Black	15	14.6	15.2	3
79600.W0419-1	Four	Natural	20.1	19.7	20.3	4
79600.W0419-4	Four	Black	20.1	19.7	20.3	4
79600.W0424-1	Four	Natural	25.1	24.8	25.4	5
79600.W0424-4	Four	Black	25.1	24.8	25.4	5
79600.W0429-1	Four	Natural	30.2	29.9	30.5	6
79600.W0429-4	Four	Black	30.2	29.9	30.5	6
79600.W0440-1	Four	Natural	40.4	40.0	40.6	8
79600.W0440-4	Four	Black	40.4	40	40.6	8
79600.W0460-1	Four	Natural	60.4	60.3	60.7	12
79600.W0460-4	Four	Black	60.4	60.3	60.7	12
79600.W0470-1	Four	Natural	70.9	70.5	71.1	14
79600.W0470-4	Four	Black	70.9	70.5	71.1	14
79600.W0499-1	Four	Natural	101.3	101.0	101.6	20
79600.W0499-4	Four	Black	101.3	101.0	101.6	20

PULL HANDLES



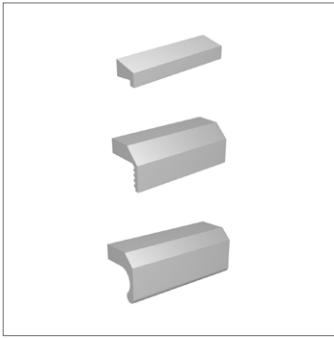

79610

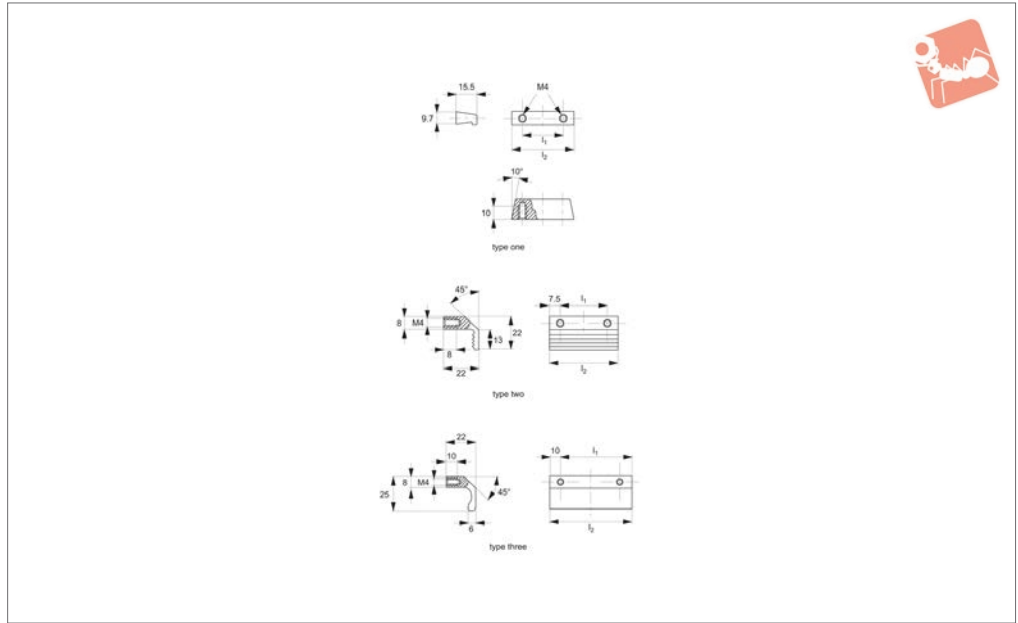

Material

Profiled aluminium AlMgSi 0.5. Vibration ground, and anodized with a matt finish in natural colour or black.

Technical Notes

Minimum stress resistance 200N.

Important Notes

Any other handle lengths available upon request.

Order No.	Type	Colour	l ₂	l ₁
79610.W0045-1	Type One	Natural	60	45
79610.W0045-4	Type One	Black	60	45
79610.W0070-1	Type One	Natural	85	70
79610.W0070-4	Type One	Black	85	70
79610.W0090-1	Type One	Natural	105	90
79610.W0090-4	Type One	Black	105	90
79610.W0099-1	Type One	Natural	120	105
79610.W0099-4	Type One	Black	120	105
79610.W0145-1	Type Two	Natural	60	45
79610.W0145-4	Type Two	Black	60	45
79610.W0170-1	Type Two	Natural	85	70
79610.W0170-4	Type Two	Black	85	70
79610.W0190-1	Type Two	Natural	105	90
79610.W0190-4	Type Two	Black	105	90
79610.W0199-1	Type Two	Natural	120	105
79610.W0199-4	Type Two	Black	120	105
79610.W0245-1	Type Three	Natural	65	45
79610.W0245-4	Type Three	Black	65	45
79610.W0264-1	Type Three	Natural	84	64
79610.W0264-4	Type Three	Black	84	64
79610.W0270-1	Type Three	Natural	90	70
79610.W0270-4	Type Three	Black	90	70
79610.W0280-1	Type Three	Natural	100	80
79610.W0280-4	Type Three	Black	100	80
79610.W0290-1	Type Three	Natural	110	90
79610.W0290-4	Type Three	Black	110	90

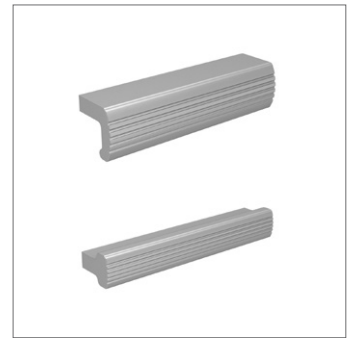
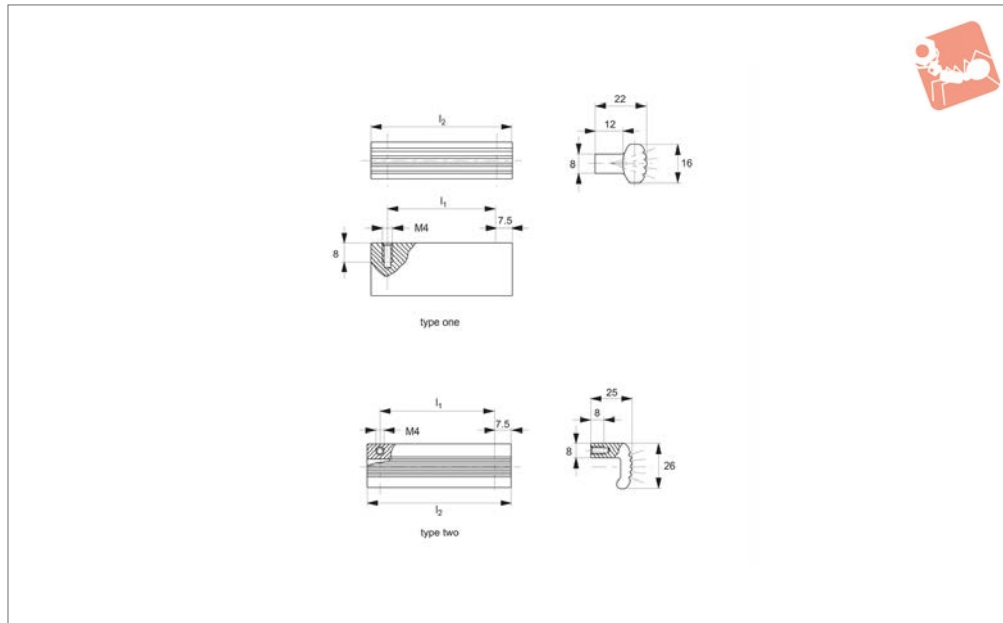

79620

PULL HANDLES

Material

Profiled aluminium AlMgSi 0.5. Vibro-polished and anodized to a matt finish.

Technical Notes

Minimum stress resistance 200N.

Order No.	Type	Finish	l ₂	l ₁
79620.W0030-1	One	Natural	45	30
79620.W0030-4	One	Black	45	30
79620.W0045-1	One	Natural	60	45
79620.W0045-4	One	Black	60	45
79620.W0070-1	One	Natural	85	70
79620.W0070-4	One	Black	85	70
79620.W0090-1	One	Natural	105	90
79620.W0090-4	One	Black	105	90
79620.W0105-1	One	Natural	120	105
79620.W0105-4	One	Black	120	105
79620.W0120-1	One	Natural	135	120
79620.W0120-4	One	Black	135	120
79620.W0530-1	Two	Natural	45	30
79620.W0530-4	Two	Black	45	30
79620.W0545-1	Two	Natural	60	45
79620.W0545-4	Two	Black	60	45
79620.W0570-1	Two	Natural	85	70
79620.W0570-4	Two	Black	85	70
79620.W0590-1	Two	Natural	105	90
79620.W0590-4	Two	Black	105	90
79620.W0605-1	Two	Natural	120	105
79620.W0605-4	Two	Black	120	105
79620.W0620-1	Two	Natural	135	120
79620.W0620-4	Two	Black	135	120



PULL HANDLES



79630

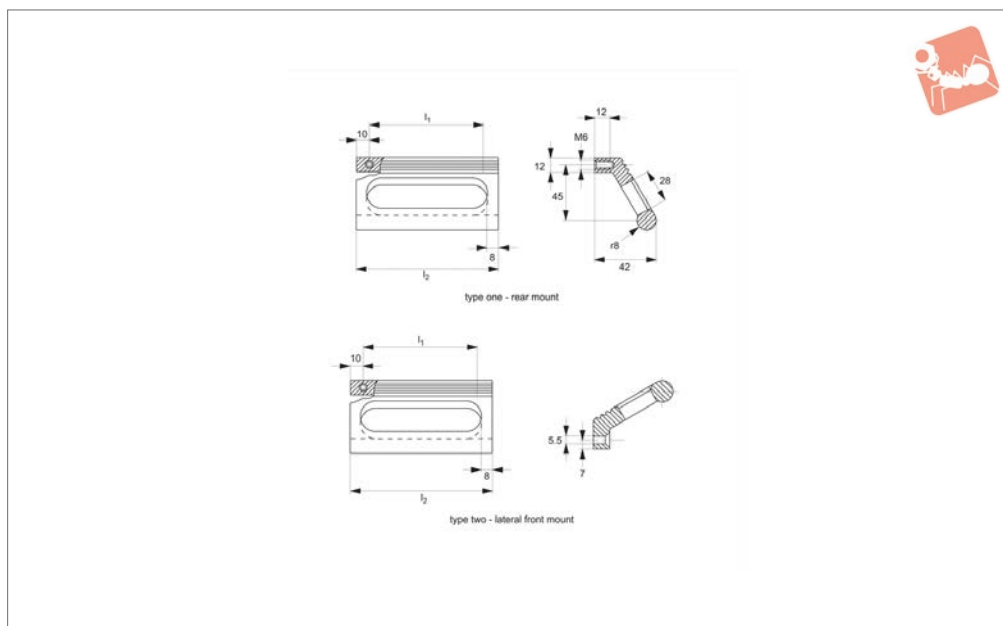

Material

Profile aluminium ALMgSi 0,5. Satin finish anodized in 3 colours.

Technical Notes

Type one: internal thread M 6. Minimum stress resistance 500N.

Type two: through hole for M 5 counter sunk screw, lateral assembly.

Order No.	Type	Finish	l_2	l_1
79630.W0086-1	One	Natural	106	86
79630.W0086-4	One	Black	106	86
79630.W0100-1	One	Natural	120	100
79630.W0100-4	One	Black	120	100
79630.W0120-1	One	Natural	140	120
79630.W0120-4	One	Black	140	120
79630.W0586-1	Two	Natural	106	86
79630.W0586-4	Two	Black	106	86
79630.W0600-1	Two	Natural	120	100
79630.W0600-4	Two	Black	120	100
79630.W0620-1	Two	Natural	140	120
79630.W0620-4	Two	Black	140	120

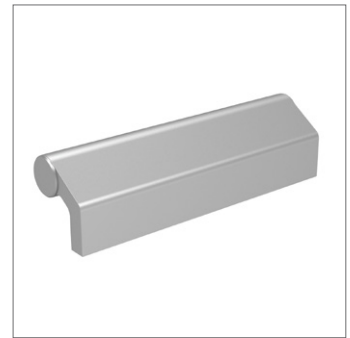
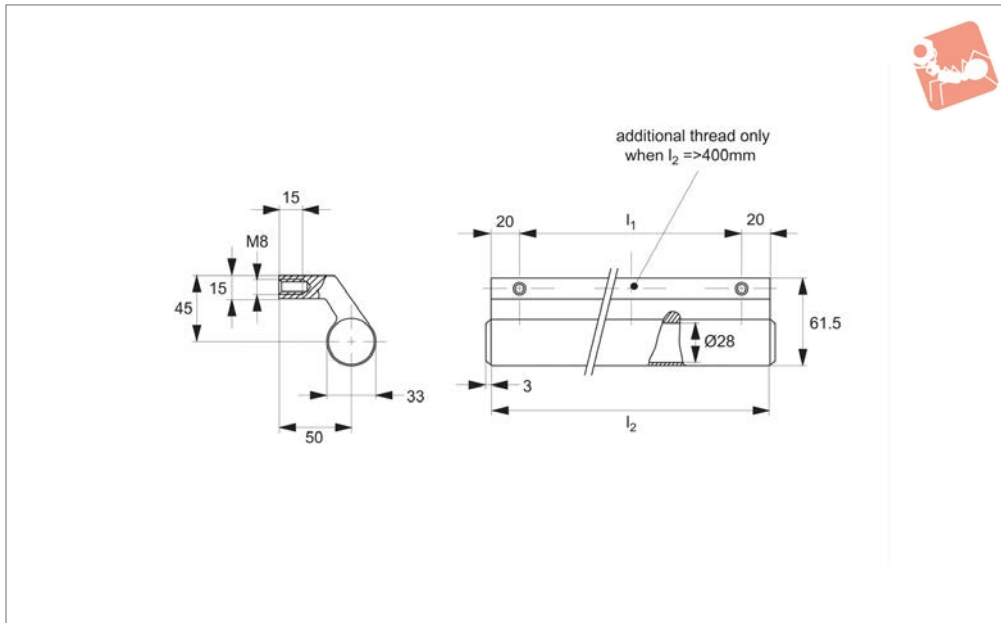

79650

PULL HANDLES

Material

Handle: aluminium section AlMgSi 0.5.
Semi-gloss anodizing in natural colour or black powder coated with fine structure.
End caps: polyamide, black, with fine-grain

structure.

Technical Notes

Minimum stress resistance >1000N.

Tips

For sliding doors and drawers in machinery and technical plants, also suitable as edge protection.

Order No.	Colour	l_2	l_1
79650.W0110-1	Natural	150	110
79650.W0110-4	Black	150	110
79650.W0160-1	Natural	200	160
79650.W0160-4	Black	200	160
79650.W0210-1	Natural	250	210
79650.W0210-4	Black	250	210
79650.W0260-1	Natural	300	260
79650.W0260-4	Black	300	260
79650.W0310-1	Natural	350	310
79650.W0310-4	Black	350	310
79650.W0360-1	Natural	400	360
79650.W0360-4	Black	400	360
79650.W0460-1	Natural	500	460
79650.W0460-4	Black	500	460
79650.W0560-1	Natural	600	560
79650.W0560-4	Black	600	560



74760

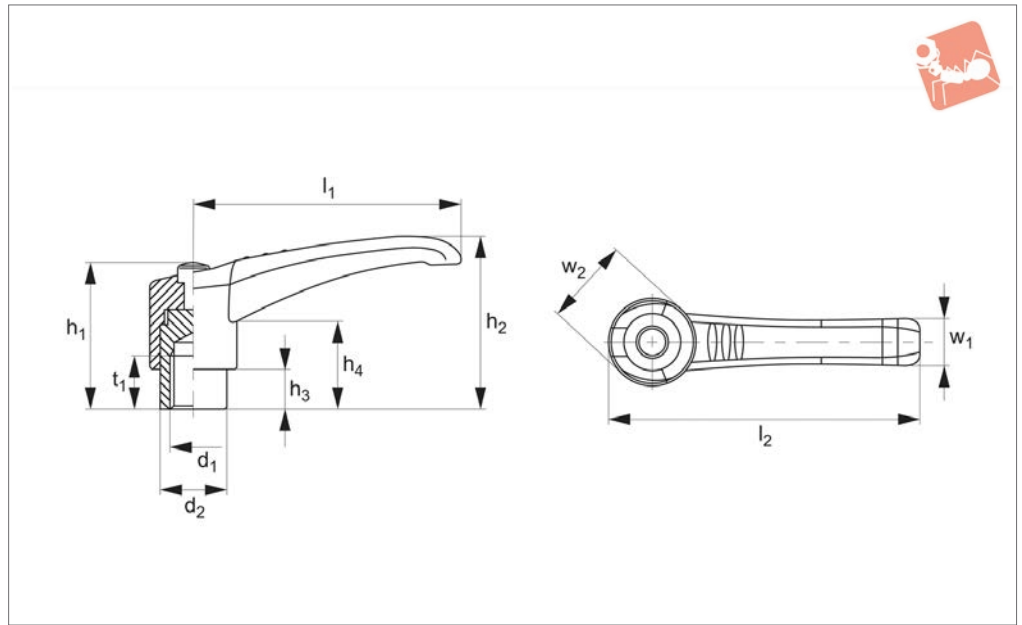

Material

Black, matt thermoplast, reinforced.
Insert: zinc plated steel.

Button: black.

subject to minimum quantities.

Important Notes

Other button colours available on request

Order No.	l_1	d_1	l_2	d_2	h_1	h_2	h_3	h_4	t_1	w_1	w_2	Weight g
74760.W0452	45	M 5	53	12	30	33.5	7.5	18	8	10.5	16	22
74760.W0453	45	M 6	53	12	30	33.5	7.5	18	8	10.5	16	24
74760.W0652	65	M 6	75	15	35	41.0	7.5	19	11	13.5	20	26
74760.W0653	65	M 8	75	15	35	41.0	7.5	19	11	13.5	20	24
74760.W0801	80	M 8	92	20	45	53.0	12.0	26	16	16.5	24	55
74760.W0802	80	M10	92	20	45	53.0	12.0	26	16	16.5	24	56
74760.W0803	80	M12	92	20	45	53.0	12.0	26	16	16.5	24	57
74760.W0951	95	M12	108	21	50	61.0	13.0	30	22	19.0	27	83
74760.W0952	95	M14	108	21	50	61.0	13.0	30	22	19.0	27	94
74760.W0953	95	M16	108	21	50	61.0	13.0	30	22	19.0	27	89



Adjustable Clamping Levers with grub screw

Clamping Levers

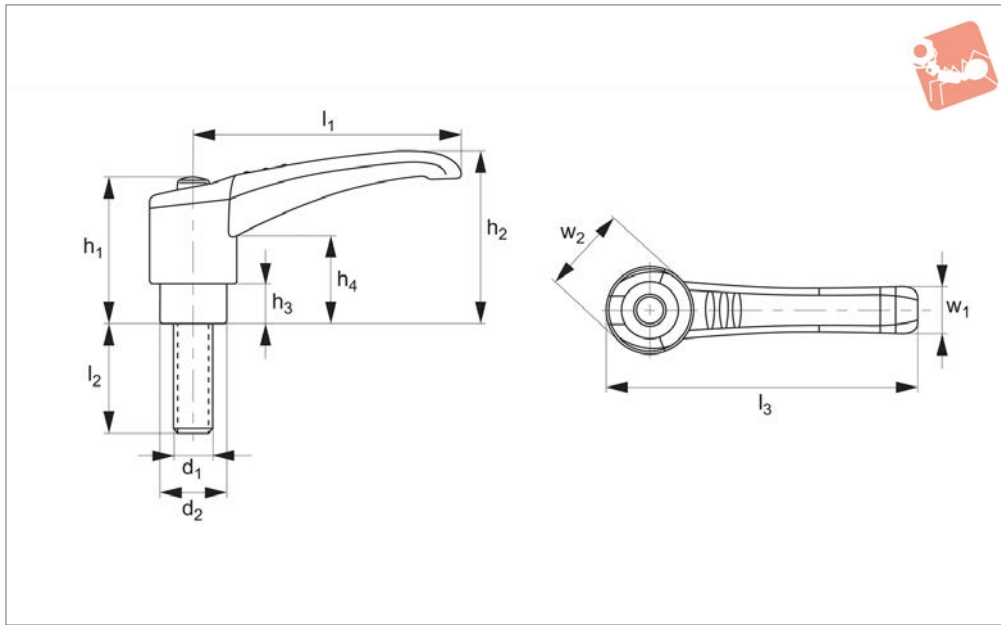

74780

CLAMPING LEVERS

Material

Black, matt thermoplast, reinforced.
Insert, zinc plated steel.

Button: black.

subject to minimum quantities.

Important Notes

Other button colours available on request

Order No.	l_1	d_1	l_2	d_2	h_1	h_2	h_3	h_4	l_3	w_1	w_2	Weight g
74780.W0452	45	M 5	20	12	29	33.5	7.5	18	53	10.5	16	19
74780.W0453	45	M 5	30	12	29	33.5	7.5	18	53	10.5	16	20
74780.W0455	45	M 6	20	12	29	33.5	7.5	18	53	10.5	16	20
74780.W0651	65	M 6	20	15	34	41.0	7.5	19	75	13.5	20	30
74780.W0652	65	M 6	40	15	34	41.0	7.5	19	75	13.5	20	33
74780.W0653	65	M 8	20	15	34	41.0	7.5	19	75	13.5	20	35
74780.W0654	65	M 8	30	15	34	41.0	7.5	19	75	13.5	20	38
74780.W0655	65	M 8	40	15	34	41.0	7.5	19	75	13.5	20	44
74780.W0801	80	M 8	30	20	44	53.0	12.0	26	92	16.5	24	61
74780.W0802	80	M 8	40	20	44	53.0	12.0	26	92	16.5	24	78
74780.W0803	80	M 8	50	20	44	53.0	12.0	26	92	16.5	24	81
74780.W0804	80	M10	20	20	44	53.0	12.0	26	92	16.5	24	74
74780.W0805	80	M10	40	20	44	53.0	12.0	26	92	16.5	24	85
74780.W0806	80	M10	50	20	44	53.0	12.0	26	92	16.5	24	89
74780.W0807	80	M12	40	20	44	53.0	12.0	26	92	16.5	24	101
74780.W0808	80	M12	50	20	44	53.0	12.0	26	92	16.5	24	108
74780.W0951	95	M12	50	21	50	61.0	13.0	30	108	19.0	27	139
74780.W0952	95	M12	70	21	50	61.0	13.0	30	108	19.0	27	154
74780.W0953	95	M14	40	21	50	61.0	13.0	30	108	19.0	27	150
74780.W0954	95	M14	50	21	50	61.0	13.0	30	108	19.0	27	166
74780.W0955	95	M16	50	21	50	61.0	13.0	30	108	19.0	27	193
74780.W0956	95	M16	60	21	50	61.0	13.0	30	108	19.0	27	220



CLAMPING LEVERS



74800

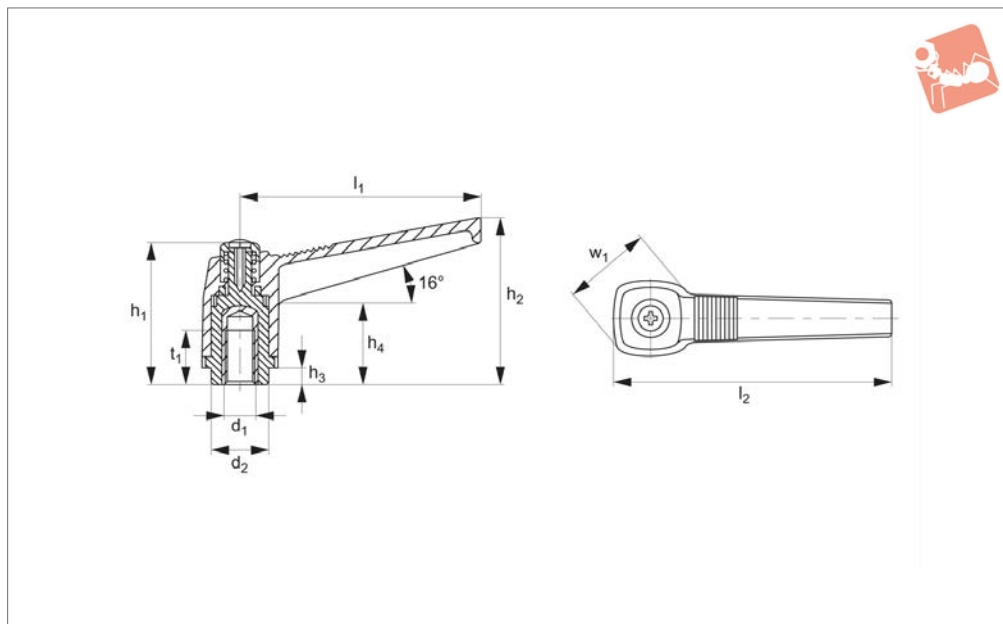

Material

Black, matt thermoplastic, reinforced.
Brass insert.

Technical Notes

Special size and colours available on request, subject to minimum order quantity.

tity.

Order No.	l_1	d_1	l_2	d_2	h_1	h_2	h_3	h_4	t_1	w_1	Weight g
74800.W0421	42	M 4	50	12	29	32	3	17	9	19	11
74800.W0422	42	M 5	50	12	29	32	3	17	9	19	11
74800.W0423	42	M 6	50	12	29	32	3	17	9	19	11
74800.W0631	63	M 5	73	15	39	43	4	21	13	25	23
74800.W0632	63	M 6	73	15	39	43	4	21	13	25	23
74800.W0633	63	M 8	73	15	39	43	4	21	13	25	24
74800.W0801	80	M 8	92	19	48	54	6	27	15	30	44
74800.W0802	80	M10	92	19	48	54	6	27	16	30	44
74800.W0803	80	M12	92	19	48	54	6	27	18	30	45
74800.W0901	100	M12	115	25	58	66	8	30	18	36	83
74800.W0902	100	M14	115	25	58	66	8	30	20	36	84
74800.W0903	100	M16	115	25	58	66	8	30	20	36	87



Adjustable Clamping Levers

grub screw



Clamping Levers

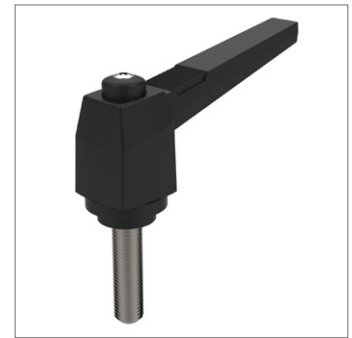
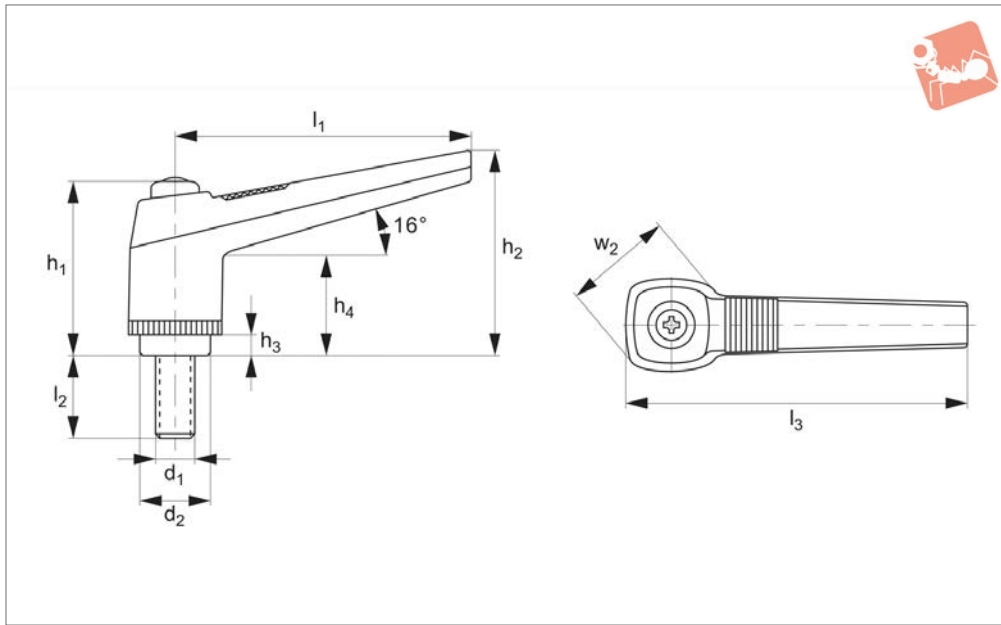

74820

CLAMPING LEVERS

Material

Black, thermoplastic, glass fibre reinforced. Zinc plated steel stud.

Technical Notes

Special size and colours available on request, subject to minimum order quantity.

tity.

Order No.	l_1	d_1	l_2	d_2	h_1	h_2	h_3	h_4	l_3	w_2	Weight g
74820.W0541	42	M 4	20	12	29	32	3	17	50	19	11
74820.W0542	42	M 5	20	12	29	32	3	17	50	19	13
74820.W0543	42	M 5	30	12	29	32	3	17	50	19	14
74820.W0544	42	M 6	20	12	29	32	3	17	50	19	15
74820.W0545	42	M 6	30	12	29	32	3	17	50	19	16
74820.W0560	63	M 5	20	15	39	43	4	21	73	25	24
74820.W0561	63	M 6	20	15	39	43	4	21	73	25	28
74820.W0562	63	M 6	25	15	39	43	4	21	73	25	25
74820.W0563	63	M 6	40	15	39	43	4	21	73	25	31
74820.W0564	63	M 8	20	15	39	43	4	21	73	25	33
74820.W0565	63	M 8	25	15	39	43	4	21	73	25	34
74820.W0566	63	M 8	30	15	39	43	4	21	73	25	36
74820.W0567	63	M 8	40	15	39	43	4	21	73	25	38
74820.W0568	63	M 8	50	15	39	43	4	21	73	25	39
74820.W0580	80	M 8	20	19	48	54	6	27	92	30	48
74820.W0581	80	M 8	30	19	48	54	6	27	92	30	51
74820.W0582	80	M 8	40	19	48	54	6	27	92	30	55
74820.W0583	80	M 8	50	19	48	54	6	27	92	30	58
74820.W0584	80	M10	25	19	48	54	6	27	92	30	58
74820.W0585	80	M10	40	19	48	54	6	27	92	30	66
74820.W0586	80	M10	50	19	48	54	6	27	92	30	71
74820.W0587	80	M10	60	19	48	54	6	27	92	30	78
74820.W0588	80	M12	30	19	48	54	6	27	92	30	82
74820.W0589	80	M12	60	19	48	54	6	27	92	30	102
74820.W0600	100	M12	40	25	58	66	8	30	115	36	120
74820.W0601	100	M12	50	25	58	66	8	30	115	36	126
74820.W0602	100	M12	70	25	58	66	8	30	115	36	149
74820.W0603	100	M14	40	25	58	66	8	30	115	36	146
74820.W0604	100	M14	50	25	58	66	8	30	115	36	162
74820.W0605	100	M14	70	25	58	66	8	30	115	36	181
74820.W0606	100	M16	40	25	58	66	8	30	115	36	170
74820.W0607	100	M16	50	25	58	66	8	30	115	36	184
74820.W0608	100	M16	70	25	58	66	8	30	115	36	210



74830

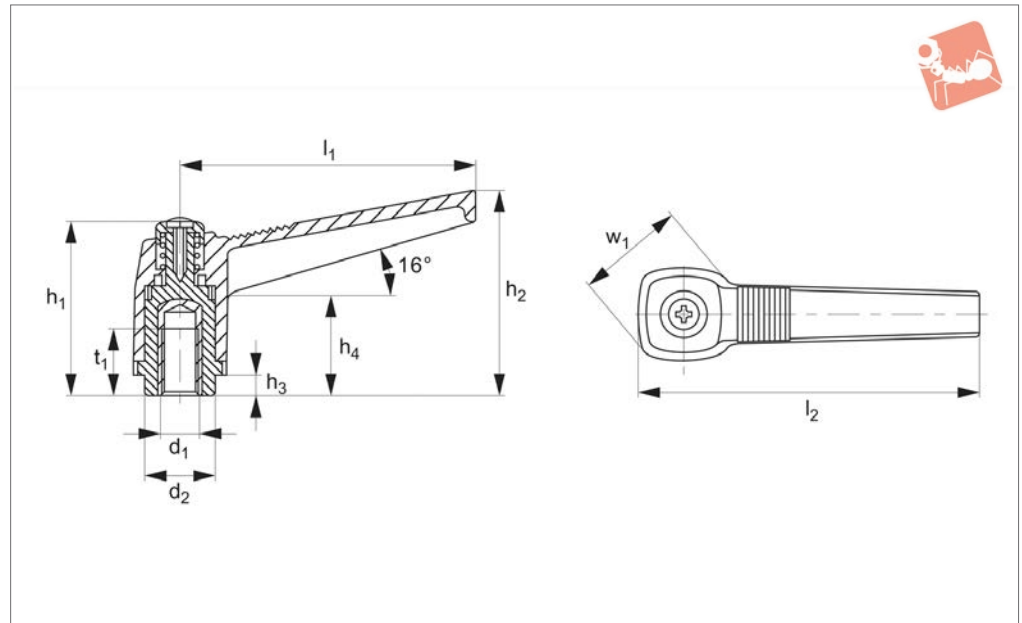

Material

Black, matt thermoplastic, reinforced.
Stainless steel insert.

Technical Notes

For certain minimum quantities, colours are available on request.

Order No.	l_1	d_1	l_2	d_2	h_1	h_2	h_3	h_4	t_1	w_1	Weight g
74830.W0423	42	M 6	50	12	29	32	3	17	9	19	11
74830.W0633	63	M 8	73	15	39	43	4	21	13	25	24
74830.W0802	80	M10	92	19	48	54	6	27	16	30	44



Adjustable Clamping Levers

stainless steel thread - grub screw

Clamping Levers

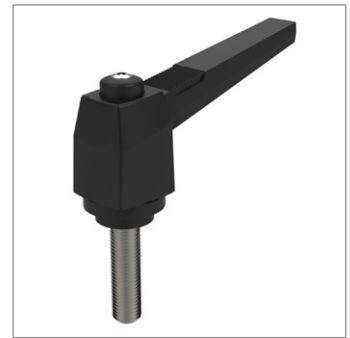
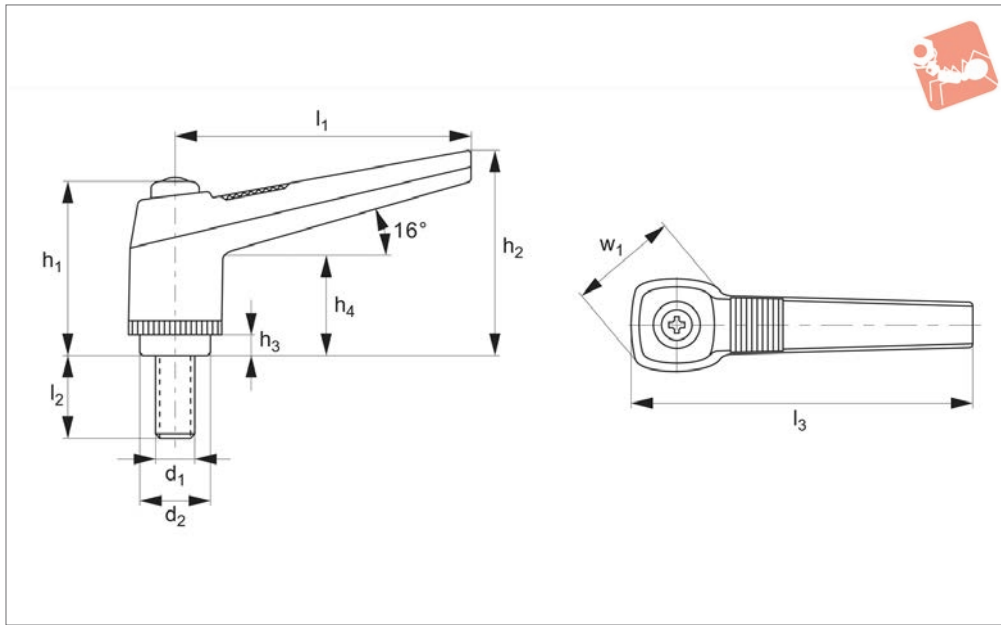

74840

CLAMPING LEVERS

Material

Black, matt thermoplastic with stainless steel thread AISI 303 (1.4305).

Technical Notes

Special colours available on request, subject to minimum order quantity.

Order No.	l_1	d_1	l_2	d_2	h_1	h_2	h_3	h_4	l_3	w_1	Weight g
74840.W0420	42	M 6	20	12	29	32	3	17	50	19	15
74840.W0430	42	M 6	30	12	29	32	3	17	50	19	16
74840.W0620	63	M 8	20	15	39	43	4	21	73	25	33
74840.W0625	63	M 8	25	15	39	43	4	21	73	25	34
74840.W0630	63	M 8	30	15	39	43	4	21	73	25	36
74840.W0825	80	M10	25	19	48	54	6	27	92	30	58
74840.W0830	80	M10	30	19	48	54	6	27	92	30	61



74410

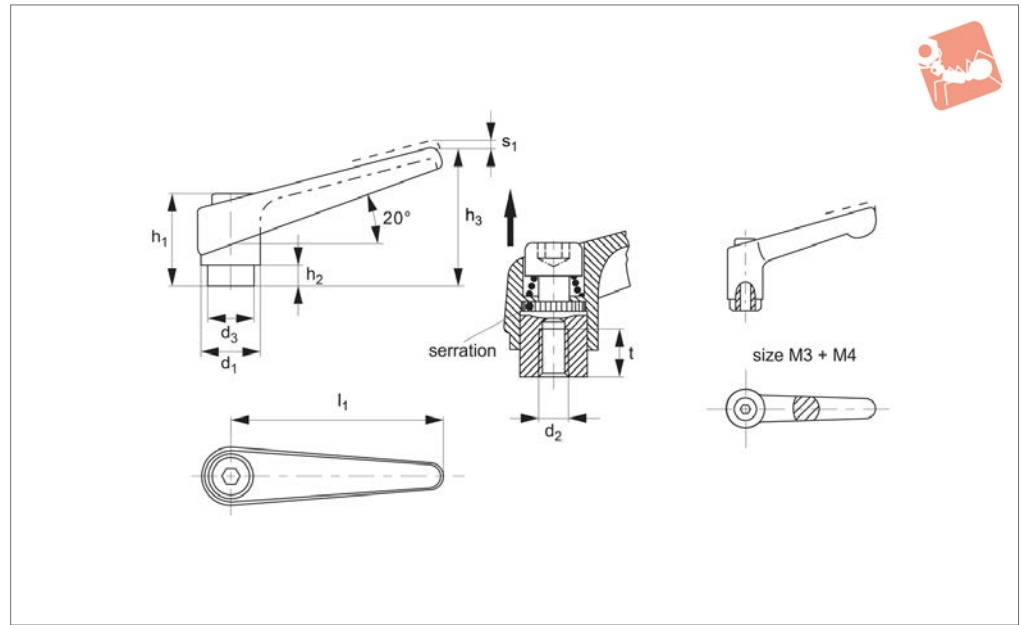

Material

Handle: die-cast zinc.

- Orange RAL 2004
- Black RAL 9005
- Silver RAL 9006

Inner parts: steel, quality 5.8, blackened.
Threaded part: steel, quality 5, blackened.

Technical Notes

By lifting the lever, the serrations are

disengaged. The handle can be positioned by the serrations, and the threaded insert can be exchanged. Upon releasing the handle, the serrations are automatically re-engaged.

Order No.	Colour	Finish	d ₁	d ₂	d ₃	h ₁	h ₂	h ₃	l ₂	Stroke s ₁	t ≤	Weight g
74410.W0032	Orange	Female	13	M 3	10.0	24.5	4.0	30.5	30	3.5	7	25
74410.W0034	Black	Female	13	M 3	10.0	24.5	4.0	30.5	30	3.5	7	25
74410.W0035	Black	Female	13	M 3	10.0	24.5	4.0	30.5	30	3.5	7	26
74410.W0036	Orange	Female	13	M 4	10.0	24.5	4.0	30.5	30	3.5	9	25
74410.W0038	Black	Female	13	M 4	10.0	24.5	4.0	30.5	30	3.5	9	25
74410.W0040	Black	Female	13	M 4	10.0	24.5	4.0	30.5	30	3.5	9	25
74410.W0111	Orange	Female	14	M 5	10.0	24.5	4.0	35.0	45	3.0	8	33
74410.W0113	Grey	Female	14	M 5	10.0	24.5	4.0	35.0	45	3.0	8	33
74410.W0114	Black	Female	14	M 5	10.0	24.5	4.0	35.0	45	3.0	8	33
74410.W0121	Orange	Female	14	M 6	10.0	24.5	4.0	35.0	45	3.0	8	33
74410.W0123	Grey	Female	14	M 6	10.0	24.5	4.0	35.0	45	3.0	8	33
74410.W0124	Black	Female	14	M 6	10.0	24.5	4.0	35.0	45	3.0	8	33
74410.W0311	Orange	Female	18	M 6	13.5	31.0	6.5	45.0	62	3.0	10	67
74410.W0313	Grey	Female	18	M 6	13.5	31.0	6.5	45.0	62	3.0	10	67
74410.W0314	Black	Female	18	M 6	13.5	31.0	6.5	45.0	62	3.0	10	67
74410.W0321	Orange	Female	18	M 8	13.5	31.0	6.5	45.0	62	3.0	10	67
74410.W0323	Grey	Female	18	M 8	13.5	31.0	6.5	45.0	62	3.0	10	67
74410.W0324	Black	Female	18	M 8	13.5	31.0	6.5	45.0	62	3.0	10	67
74410.W0411	Orange	Female	22	M 8	16.0	36.0	8.0	52.0	74	3.5	14	112
74410.W0413	Grey	Female	22	M 8	16.0	36.0	8.0	52.0	74	3.5	14	112
74410.W0414	Black	Female	22	M 8	16.0	36.0	8.0	52.0	74	3.5	14	112
74410.W0421	Orange	Female	22	M10	16.0	36.0	8.0	52.0	74	3.5	14	109
74410.W0423	Grey	Female	22	M10	16.0	36.0	8.0	52.0	74	3.5	14	109
74410.W0424	Black	Female	22	M10	16.0	36.0	8.0	52.0	74	3.5	14	109
74410.W0511	Orange	Female	25	M10	19.0	43.0	11.0	63.0	89	4.0	17	176
74410.W0513	Grey	Female	25	M10	19.0	43.0	11.0	63.0	89	4.0	17	176
74410.W0514	Black	Female	25	M10	19.0	43.0	11.0	63.0	89	4.0	17	176
74410.W0521	Orange	Female	25	M12	19.0	43.0	11.0	63.0	89	4.0	17	171
74410.W0523	Grey	Female	25	M12	19.0	43.0	11.0	63.0	89	4.0	17	171
74410.W0524	Black	Female	25	M12	19.0	43.0	11.0	63.0	89	4.0	17	171
74410.W0611	Orange	Female	30	M12	23.0	50.5	12.0	76.0	108	5.0	22	286
74410.W0613	Grey	Female	30	M12	23.0	50.5	12.0	76.0	108	5.0	22	286
74410.W0614	Black	Female	30	M12	23.0	50.5	12.0	76.0	108	5.0	22	286



Adjustable Clamping Levers

threaded bore



Order No.	Colour	Finish	d ₁	d ₂	d ₃	h ₁	h ₂	h ₃	l ₂	Stroke s ₁	t ≤	Weight g
74410.W0621	Orange	Female	30	M16	23.0	50.5	12.0	76.0	108	5.0	22	269
74410.W0623	Grey	Female	30	M16	23.0	50.5	12.0	76.0	108	5.0	22	269
74410.W0624	Black	Female	30	M16	23.0	50.5	12.0	76.0	108	5.0	22	269



74430

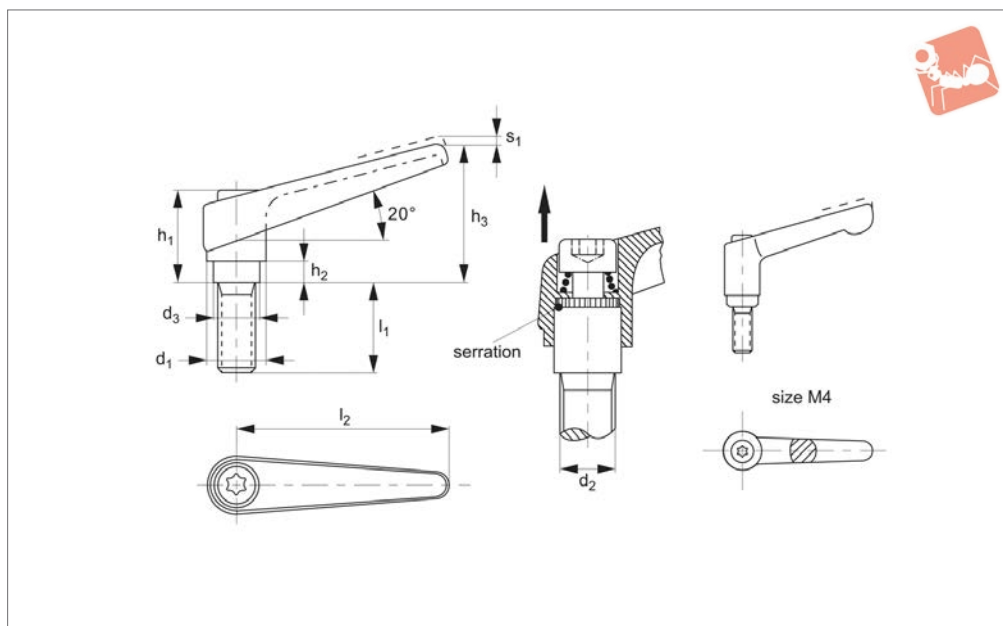

Material

Handle: die-cast zinc.

- Orange RAL 2004
- Black RAL 9005
- Silver RAL 9006.

Inner parts: steel, quality 5.8, blackened
Screw: steel, quality 5.8, blackened.

Technical Notes

By lifting the lever, the serrations are

disengaged. The handle can be positioned by the serrations, and the threaded insert can be exchanged. Upon releasing the handle, the serrations are automatically re-engaged. The collar screw is torx head.

Order No.	Colour	Finish	d ₁	d ₂	d ₃	h ₁	h ₂	h ₃	l ₁	l ₂	Stroke s ₁	Weight g
74430.W0010	Orange	Male thread	13	M 4	10.0	24.5	4.0	30.5	12	30	3.5	27
74430.W0012	Black	Male thread	13	M 4	10.0	24.5	4.0	30.5	12	30	3.5	27
74430.W0014	Orange	Male thread	13	M 4	10.0	24.5	4.0	30.5	16	30	3.5	27
74430.W0016	Black	Male thread	13	M 4	10.0	24.5	4.0	30.5	16	30	3.5	27
74430.W0018	Orange	Male thread	13	M 4	10.0	24.5	4.0	30.5	20	30	3.5	27
74430.W0020	Black	Male thread	13	M 4	10.0	24.5	4.0	30.5	20	30	3.5	27
74430.W0022	Orange	Male thread	13	M 4	10.0	24.5	4.0	30.5	25	30	3.5	28
74430.W0024	Black	Male thread	13	M 4	10.0	24.5	4.0	30.5	25	30	3.5	28
74430.W0026	Orange	Male thread	13	M 4	10.0	24.5	4.0	30.5	32	30	3.5	28
74430.W0028	Black	Male thread	13	M 4	10.0	24.5	4.0	30.5	32	30	3.5	28
74430.W0041	Orange	Male thread	14	M 5	10.0	24.5	4.0	35.0	12	45	3.0	36
74430.W0043	Grey	Male thread	14	M 5	10.0	24.5	4.0	35.0	12	45	3.0	36
74430.W0044	Black	Male thread	14	M 5	10.0	24.5	4.0	35.0	12	45	3.0	36
74430.W0051	Orange	Male thread	14	M 5	10.0	24.5	4.0	35.0	16	45	3.0	36
74430.W0053	Grey	Male thread	14	M 5	10.0	24.5	4.0	35.0	16	45	3.0	36
74430.W0054	Black	Male thread	14	M 5	10.0	24.5	4.0	35.0	16	45	3.0	36
74430.W0061	Orange	Male thread	14	M 5	10.0	24.5	4.0	35.0	20	45	3.0	37
74430.W0063	Grey	Male thread	14	M 5	10.0	24.5	4.0	35.0	20	45	3.0	37
74430.W0064	Black	Male thread	14	M 5	10.0	24.5	4.0	35.0	20	45	3.0	37
74430.W0071	Orange	Male thread	14	M 5	10.0	24.5	4.0	35.0	25	45	3.0	38
74430.W0073	Grey	Male thread	14	M 5	10.0	24.5	4.0	35.0	25	45	3.0	38
74430.W0074	Black	Male thread	14	M 5	10.0	24.5	4.0	35.0	25	45	3.0	38
74430.W0081	Orange	Male thread	14	M 5	10.0	24.5	4.0	35.0	32	45	3.0	38
74430.W0083	Grey	Male thread	14	M 5	10.0	24.5	4.0	35.0	32	45	3.0	38
74430.W0084	Black	Male thread	14	M 5	10.0	24.5	4.0	35.0	32	45	3.0	38
74430.W0086	Orange	Male thread	14	M 5	10.0	24.5	4.0	35.0	40	45	3.0	39
74430.W0088	Grey	Male thread	14	M 5	10.0	24.5	4.0	35.0	40	45	3.0	39
74430.W0089	Black	Male thread	14	M 5	10.0	24.5	4.0	35.0	40	45	3.0	39
74430.W0131	Orange	Male thread	14	M 6	10.0	24.5	4.0	35.0	12	45	3.0	37
74430.W0133	Grey	Male thread	14	M 6	10.0	24.5	4.0	35.0	12	45	3.0	37
74430.W0134	Black	Male thread	14	M 6	10.0	24.5	4.0	35.0	12	45	3.0	37
74430.W0141	Orange	Male thread	14	M 6	10.0	24.5	4.0	35.0	16	45	3.0	37
74430.W0143	Grey	Male thread	14	M 6	10.0	24.5	4.0	35.0	16	45	3.0	37



Adjustable Clamping Levers

with grub screw



Order No.	Colour	Finish	d ₁	d ₂	d ₃	h ₁	h ₂	h ₃	l ₁	l ₂	Stroke s ₁	Weight g
74430.W0144	Black	Male thread	14	M 6	10.0	24.5	4.0	35.0	16	45	3.0	37
74430.W0151	Orange	Male thread	14	M 6	10.0	24.5	4.0	35.0	20	45	3.0	38
74430.W0153	Grey	Male thread	14	M 6	10.0	24.5	4.0	35.0	20	45	3.0	38
74430.W0154	Black	Male thread	14	M 6	10.0	24.5	4.0	35.0	20	45	3.0	38
74430.W0161	Orange	Male thread	14	M 6	10.0	24.5	4.0	35.0	25	45	3.0	39
74430.W0163	Grey	Male thread	14	M 6	10.0	24.5	4.0	35.0	25	45	3.0	39
74430.W0164	Black	Male thread	14	M 6	10.0	24.5	4.0	35.0	25	45	3.0	39
74430.W0171	Orange	Male thread	14	M 6	10.0	24.5	4.0	35.0	32	45	3.0	40
74430.W0173	Grey	Male thread	14	M 6	10.0	24.5	4.0	35.0	32	45	3.0	40
74430.W0174	Black	Male thread	14	M 6	10.0	24.5	4.0	35.0	32	45	3.0	40
74430.W0181	Orange	Male thread	14	M 6	10.0	24.5	4.0	35.0	40	45	3.0	41
74430.W0183	Grey	Male thread	14	M 6	10.0	24.5	4.0	35.0	40	45	3.0	41
74430.W0184	Black	Male thread	14	M 6	10.0	24.5	4.0	35.0	40	45	3.0	41
74430.W0191	Orange	Male thread	14	M 6	10.0	24.5	4.0	35.0	50	45	3.0	43
74430.W0193	Grey	Male thread	14	M 6	10.0	24.5	4.0	35.0	50	45	3.0	43
74430.W0194	Black	Male thread	14	M 6	10.0	24.5	4.0	35.0	50	45	3.0	43
74430.W0221	Orange	Male thread	18	M 6	13.5	31.0	6.5	45.0	16	62	3.0	72
74430.W0223	Grey	Male thread	18	M 6	13.5	31.0	6.5	45.0	16	62	3.0	72
74430.W0224	Black	Male thread	18	M 6	13.5	31.0	6.5	45.0	16	62	3.0	72
74430.W0231	Orange	Male thread	18	M 6	13.5	31.0	6.5	45.0	20	62	3.0	72
74430.W0233	Grey	Male thread	18	M 6	13.5	31.0	6.5	45.0	20	62	3.0	72
74430.W0234	Black	Male thread	18	M 6	13.5	31.0	6.5	45.0	20	62	3.0	72
74430.W0241	Orange	Male thread	18	M 6	13.5	31.0	6.5	45.0	25	62	3.0	74
74430.W0243	Grey	Male thread	18	M 6	13.5	31.0	6.5	45.0	25	62	3.0	74
74430.W0244	Black	Male thread	18	M 6	13.5	31.0	6.5	45.0	25	62	3.0	74
74430.W0251	Orange	Male thread	18	M 6	13.5	31.0	6.5	45.0	32	62	3.0	74
74430.W0253	Grey	Male thread	18	M 6	13.5	31.0	6.5	45.0	32	62	3.0	74
74430.W0254	Black	Male thread	18	M 6	13.5	31.0	6.5	45.0	32	62	3.0	74
74430.W0261	Orange	Male thread	18	M 6	13.5	31.0	6.5	45.0	40	62	3.0	76
74430.W0263	Grey	Male thread	18	M 6	13.5	31.0	6.5	45.0	40	62	3.0	76
74430.W0264	Black	Male thread	18	M 6	13.5	31.0	6.5	45.0	40	62	3.0	76
74430.W0271	Orange	Male thread	18	M 6	13.5	31.0	6.5	45.0	50	62	3.0	76
74430.W0273	Grey	Male thread	18	M 6	13.5	31.0	6.5	45.0	50	62	3.0	76
74430.W0274	Black	Male thread	18	M 6	13.5	31.0	6.5	45.0	50	62	3.0	76
74430.W0281	Orange	Male thread	18	M 6	13.5	31.0	6.5	45.0	63	62	3.0	80
74430.W0283	Grey	Male thread	18	M 6	13.5	31.0	6.5	45.0	63	62	3.0	80
74430.W0284	Black	Male thread	18	M 6	13.5	31.0	6.5	45.0	63	62	3.0	80
74430.W0331	Orange	Male thread	18	M 8	13.5	31.0	6.5	45.0	16	62	3.0	74
74430.W0333	Grey	Male thread	18	M 8	13.5	31.0	6.5	45.0	16	62	3.0	74
74430.W0334	Black	Male thread	18	M 8	13.5	31.0	6.5	45.0	16	62	3.0	74
74430.W0341	Orange	Male thread	18	M 8	13.5	31.0	6.5	45.0	20	62	3.0	76
74430.W0343	Grey	Male thread	18	M 8	13.5	31.0	6.5	45.0	20	62	3.0	76
74430.W0344	Black	Male thread	18	M 8	13.5	31.0	6.5	45.0	20	62	3.0	76
74430.W0351	Orange	Male thread	18	M 8	13.5	31.0	6.5	45.0	25	62	3.0	77
74430.W0353	Grey	Male thread	18	M 8	13.5	31.0	6.5	45.0	25	62	3.0	77
74430.W0354	Black	Male thread	18	M 8	13.5	31.0	6.5	45.0	25	62	3.0	77
74430.W0361	Orange	Male thread	18	M 8	13.5	31.0	6.5	45.0	32	62	3.0	79
74430.W0363	Grey	Male thread	18	M 8	13.5	31.0	6.5	45.0	32	62	3.0	79
74430.W0364	Black	Male thread	18	M 8	13.5	31.0	6.5	45.0	32	62	3.0	79
74430.W0371	Orange	Male thread	18	M 8	13.5	31.0	6.5	45.0	40	62	3.0	81
74430.W0373	Grey	Male thread	18	M 8	13.5	31.0	6.5	45.0	40	62	3.0	81
74430.W0374	Black	Male thread	18	M 8	13.5	31.0	6.5	45.0	40	62	3.0	81
74430.W0381	Orange	Male thread	18	M 8	13.5	31.0	6.5	45.0	50	62	3.0	84
74430.W0383	Grey	Male thread	18	M 8	13.5	31.0	6.5	45.0	50	62	3.0	84
74430.W0384	Black	Male thread	18	M 8	13.5	31.0	6.5	45.0	50	62	3.0	84
74430.W0391	Orange	Male thread	18	M 8	13.5	31.0	6.5	45.0	63	62	3.0	89
74430.W0393	Grey	Male thread	18	M 8	13.5	31.0	6.5	45.0	63	62	3.0	89
74430.W0394	Black	Male thread	18	M 8	13.5	31.0	6.5	45.0	63	62	3.0	89
74430.W0441	Orange	Male thread	22	M10	16.0	36.0	8.0	52.0	20	74	3.5	128
74430.W0443	Grey	Male thread	22	M10	16.0	36.0	8.0	52.0	20	74	3.5	128
74430.W0444	Black	Male thread	22	M10	16.0	36.0	8.0	52.0	20	74	3.5	128
74430.W0451	Orange	Male thread	22	M10	16.0	36.0	8.0	52.0	25	74	3.5	130
74430.W0453	Grey	Male thread	22	M10	16.0	36.0	8.0	52.0	25	74	3.5	130
74430.W0454	Black	Male thread	22	M10	16.0	36.0	8.0	52.0	25	74	3.5	130
74430.W0461	Orange	Male thread	22	M10	16.0	36.0	8.0	52.0	32	74	3.5	134
74430.W0463	Grey	Male thread	22	M10	16.0	36.0	8.0	52.0	32	74	3.5	134
74430.W0464	Black	Male thread	22	M10	16.0	36.0	8.0	52.0	32	74	3.5	134
74430.W0471	Orange	Male thread	22	M10	16.0	36.0	8.0	52.0	40	74	3.5	138

CLAMPING LEVERS



Order No.	Colour	Finish	d ₁	d ₂	d ₃	h ₁	h ₂	h ₃	l ₁	l ₂	Stroke s ₁	Weight g
74430.W0473	Grey	Male thread	22	M10	16.0	36.0	8.0	52.0	40	74	3.5	138
74430.W0474	Black	Male thread	22	M10	16.0	36.0	8.0	52.0	40	74	3.5	138
74430.W0481	Orange	Male thread	22	M10	16.0	36.0	8.0	52.0	50	74	3.5	143
74430.W0483	Grey	Male thread	22	M10	16.0	36.0	8.0	52.0	50	74	3.5	143
74430.W0484	Black	Male thread	22	M10	16.0	36.0	8.0	52.0	50	74	3.5	143
74430.W0486	Orange	Male thread	22	M10	16.0	36.0	8.0	52.0	63	74	3.5	148
74430.W0488	Grey	Male thread	22	M10	16.0	36.0	8.0	52.0	63	74	3.5	148
74430.W0489	Black	Male thread	22	M10	16.0	36.0	8.0	52.0	63	74	3.5	148
74430.W0491	Orange	Male thread	22	M10	16.0	36.0	8.0	52.0	80	74	3.5	157
74430.W0493	Grey	Male thread	22	M10	16.0	36.0	8.0	52.0	80	74	3.5	157
74430.W0494	Black	Male thread	22	M10	16.0	36.0	8.0	52.0	80	74	3.5	157
74430.W0541	Orange	Male thread	25	M12	19.0	43.0	11.0	63.0	25	89	4.0	205
74430.W0543	Grey	Male thread	25	M12	19.0	43.0	11.0	63.0	25	89	4.0	205
74430.W0544	Black	Male thread	25	M12	19.0	43.0	11.0	63.0	25	89	4.0	205
74430.W0551	Orange	Male thread	25	M12	19.0	43.0	11.0	63.0	32	89	4.0	209
74430.W0553	Grey	Male thread	25	M12	19.0	43.0	11.0	63.0	32	89	4.0	209
74430.W0554	Black	Male thread	25	M12	19.0	43.0	11.0	63.0	32	89	4.0	209
74430.W0561	Orange	Male thread	25	M12	19.0	43.0	11.0	63.0	40	89	4.0	215
74430.W0563	Grey	Male thread	25	M12	19.0	43.0	11.0	63.0	40	89	4.0	215
74430.W0564	Black	Male thread	25	M12	19.0	43.0	11.0	63.0	40	89	4.0	215
74430.W0571	Orange	Male thread	25	M12	19.0	43.0	11.0	63.0	50	89	4.0	222
74430.W0573	Grey	Male thread	25	M12	19.0	43.0	11.0	63.0	50	89	4.0	222
74430.W0574	Black	Male thread	25	M12	19.0	43.0	11.0	63.0	50	89	4.0	222
74430.W0581	Orange	Male thread	25	M12	19.0	43.0	11.0	63.0	63	89	4.0	232
74430.W0583	Grey	Male thread	25	M12	19.0	43.0	11.0	63.0	63	89	4.0	232
74430.W0584	Black	Male thread	25	M12	19.0	43.0	11.0	63.0	63	89	4.0	232
74430.W0591	Orange	Male thread	25	M12	19.0	43.0	11.0	63.0	80	89	4.0	244
74430.W0593	Grey	Male thread	25	M12	19.0	43.0	11.0	63.0	80	89	4.0	244
74430.W0594	Black	Male thread	25	M12	19.0	43.0	11.0	63.0	80	89	4.0	244
74430.W0641	Orange	Male thread	30	M16	23.0	50.5	12.0	76.0	32	108	5.0	348
74430.W0643	Grey	Male thread	30	M16	23.0	50.5	12.0	76.0	32	108	5.0	348
74430.W0644	Black	Male thread	30	M16	23.0	50.5	12.0	76.0	32	108	5.0	348
74430.W0651	Orange	Male thread	30	M16	23.0	50.5	12.0	76.0	40	108	5.0	357
74430.W0653	Grey	Male thread	30	M16	23.0	50.5	12.0	76.0	40	108	5.0	357
74430.W0654	Black	Male thread	30	M16	23.0	50.5	12.0	76.0	40	108	5.0	357
74430.W0661	Orange	Male thread	30	M16	23.0	50.5	12.0	76.0	50	108	5.0	370
74430.W0663	Grey	Male thread	30	M16	23.0	50.5	12.0	76.0	50	108	5.0	370
74430.W0664	Black	Male thread	30	M16	23.0	50.5	12.0	76.0	50	108	5.0	370
74430.W0671	Orange	Male thread	30	M16	23.0	50.5	12.0	76.0	63	108	5.0	386
74430.W0673	Grey	Male thread	30	M16	23.0	50.5	12.0	76.0	63	108	5.0	386
74430.W0674	Black	Male thread	30	M16	23.0	50.5	12.0	76.0	63	108	5.0	386
74430.W0681	Orange	Male thread	30	M16	23.0	50.5	12.0	76.0	80	108	5.0	407
74430.W0683	Grey	Male thread	30	M16	23.0	50.5	12.0	76.0	80	108	5.0	407
74430.W0684	Black	Male thread	30	M16	23.0	50.5	12.0	76.0	80	108	5.0	407



Adjustable Clamping Levers

cast zinc, inner parts steel

Clamping Levers

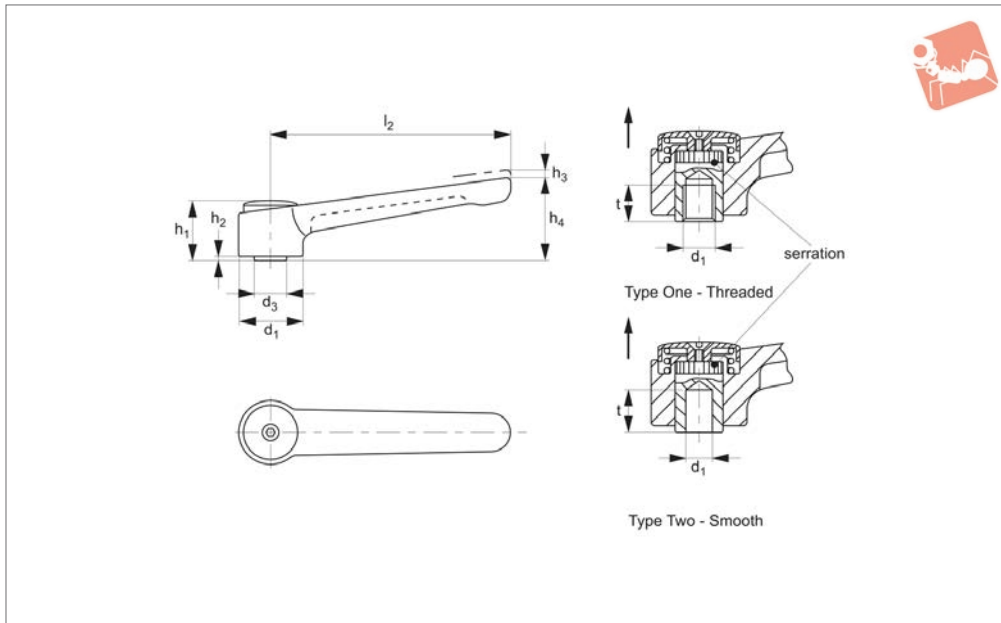

74490

CLAMPING LEVERS

Material

Lever: Zinc die-cast, plastic coated, matt
 Black - similar to RAL 9005
 Silver - similar to RAL 9006
 Inner: Steel, blackened
 Cover: Plastic.

Technical Notes

By lifting up the lever, the serrations are disengaged and the handle can then be swung to any position. On releasing the serrations are automatically re-engaged.

Available with smooth bore.

Tips

Suitable for use in restricted areas due to low height and adjustable lever.

Order No.	Type, colour	d ₁	d ₂	d ₂ tol. H7	d ₃	h ₁	h ₂	h ₃	h ₄	l ₂	t min.	Weight g
74490.W0005	One, Black	32	M 8	-	16	29.5	2	2.5	41.5	120	14	186
74490.W0010	One, Black	32	M10	-	16	29.5	2	2.5	41.5	120	14	183
74490.W0015	One, Black	32	M12	-	16	29.5	2	2.5	41.5	120	14	179
74490.W0020	One, Black	40	M12	-	23	42.0	4	4.0	56.0	145	22	313
74490.W0025	One, Black	40	M16	-	23	42.0	4	4.0	56.0	145	22	373
74490.W0105	One, Silver	32	M 8	-	16	29.5	2	2.5	41.5	120	14	186
74490.W0110	One, Silver	32	M10	-	16	29.5	2	2.5	41.5	120	14	183
74490.W0115	One, Silver	32	M12	-	16	29.5	2	2.5	41.5	120	14	179
74490.W0120	One, Silver	40	M12	-	23	42.0	4	4.0	56.0	145	22	313
74490.W0125	One, Silver	40	M16	-	23	42.0	4	4.0	56.0	145	22	373
74490.W0050	Two, Black	32	-	8	16	29.5	2	2.5	41.5	120	14	188
74490.W0051	Two, Black	32	-	10	16	29.5	2	2.5	41.5	120	14	185
74490.W0052	Two, Black	40	-	12	23	42.0	4	4.0	56.0	145	22	387
74490.W0053	Two, Black	40	-	16	23	42.0	4	4.0	56.0	145	22	389
74490.W0150	Two, Silver	32	-	8	16	29.5	2	2.5	41.5	120	14	188
74490.W0151	Two, Silver	32	-	10	16	29.5	2	2.5	41.5	120	14	185
74490.W0152	Two, Silver	40	-	12	23	42.0	4	4.0	56.0	145	22	387
74490.W0153	Two, Silver	40	-	16	23	42.0	4	4.0	56.0	145	22	389



74494

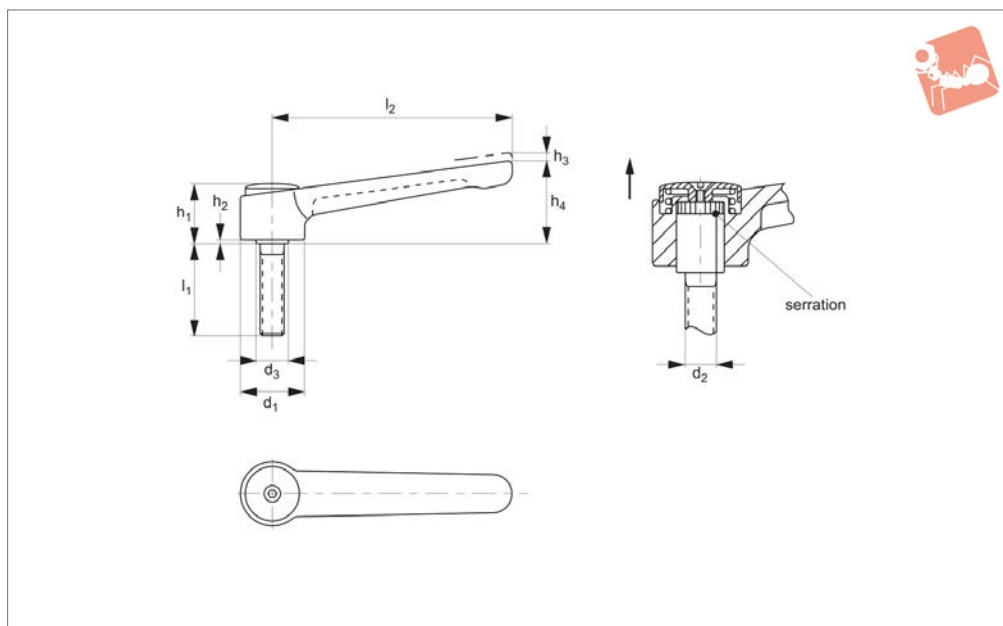

Material

Lever: Zinc die-cast, plastic coated, matt
 Black - similar to RAL 9005
 Silver - similar to RAL 9006
 Inner: Steel, blackened
 Screw: Steel, blackened
 Cover: Plastic.

Technical Notes

By lifting up the lever, the serrations are disengaged and the handle can then be swung to any position. On releasing the serrations are automatically re-engaged.

Screw part can be changed.

Tips

Suitable for use in restricted areas due to low height and adjustable lever.
 Screw part can be changed.

Order No.	Colour	d ₁	d ₂	d ₃	h ₁	h ₂	h ₃	h ₄	l ₁	l ₂	Weight g
74494.W0450	Black	32	M10	16	29.5	2	2.5	41.5	20	120	202
74494.W0455	Black	32	M10	16	29.5	2	2.5	41.5	25	120	204
74494.W0460	Black	32	M10	16	29.5	2	2.5	41.5	32	120	207
74494.W0465	Black	32	M10	16	29.5	2	2.5	41.5	40	120	211
74494.W0470	Black	32	M10	16	29.5	2	2.5	41.5	50	120	216
74494.W0475	Black	32	M10	16	29.5	2	2.5	41.5	63	120	222
74494.W0480	Black	32	M10	16	29.5	2	2.5	41.5	80	120	231
74494.W0485	Black	32	M12	16	29.5	2	2.5	41.5	20	120	206
74494.W0490	Black	32	M12	16	29.5	2	2.5	41.5	25	120	210
74494.W0495	Black	32	M12	16	29.5	2	2.5	41.5	32	120	215
74494.W0500	Black	32	M12	16	29.5	2	2.5	41.5	40	120	221
74494.W0505	Black	32	M12	16	29.5	2	2.5	41.5	50	120	228
74494.W0510	Black	32	M12	16	29.5	2	2.5	41.5	63	120	236
74494.W0515	Black	32	M12	16	29.5	2	2.5	41.5	80	120	248
74494.W0525	Black	40	M12	23	42.0	4	4.0	56.0	32	145	434
74494.W0530	Black	40	M12	23	42.0	4	4.0	56.0	40	145	440
74494.W0535	Black	40	M12	23	42.0	4	4.0	56.0	50	145	447
74494.W0540	Black	40	M12	23	42.0	4	4.0	56.0	63	145	455
74494.W0545	Black	40	M12	23	42.0	4	4.0	56.0	80	145	467
74494.W0550	Black	40	M16	23	42.0	4	4.0	56.0	32	145	449
74494.W0555	Black	40	M16	23	42.0	4	4.0	56.0	40	145	460
74494.W0560	Black	40	M16	23	42.0	4	4.0	56.0	50	145	472
74494.W0565	Black	40	M16	23	42.0	4	4.0	56.0	63	145	491
74494.W0570	Black	40	M16	23	42.0	4	4.0	56.0	80	145	513
74494.W0850	Silver	32	M10	16	29.5	2	2.5	41.5	20	120	202
74494.W0855	Silver	32	M10	16	29.5	2	2.5	41.5	25	120	204
74494.W0860	Silver	32	M10	16	29.5	2	2.5	41.5	32	120	207
74494.W0865	Silver	32	M10	16	29.5	2	2.5	41.5	40	120	211
74494.W0870	Silver	32	M10	16	29.5	2	2.5	41.5	50	120	216
74494.W0875	Silver	32	M10	16	29.5	2	2.5	41.5	63	120	222
74494.W0880	Silver	32	M10	16	29.5	2	2.5	41.5	80	120	231

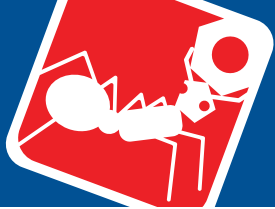

Adjustable Clamping Levers

cast zinc, inner parts steel

Clamping Levers



Order No.	Colour	d ₁	d ₂	d ₃	h ₁	h ₂	h ₃	h ₄	l ₁	l ₂	Weight g
74494.W0885	Silver	32	M12	16	29.5	2	2.5	41.5	20	120	206
74494.W0890	Silver	32	M12	16	29.5	2	2.5	41.5	25	120	210
74494.W0895	Silver	32	M12	16	29.5	2	2.5	41.5	32	120	215
74494.W0900	Silver	32	M12	16	29.5	2	2.5	41.5	40	120	221
74494.W0905	Silver	32	M12	16	29.5	2	2.5	41.5	50	120	228
74494.W0910	Silver	32	M12	16	29.5	2	2.5	41.5	63	120	236
74494.W0915	Silver	32	M12	16	29.5	2	2.5	41.5	80	120	248
74494.W0925	Silver	40	M12	23	42.0	4	4.0	56.0	32	145	434
74494.W0930	Silver	40	M12	23	42.0	4	4.0	56.0	40	145	440
74494.W0935	Silver	40	M12	23	42.0	4	4.0	56.0	50	145	447
74494.W0940	Silver	40	M12	23	42.0	4	4.0	56.0	63	145	455
74494.W0945	Silver	40	M12	23	42.0	4	4.0	56.0	80	145	467
74494.W0950	Silver	40	M16	23	42.0	4	4.0	56.0	32	145	449
74494.W0955	Silver	40	M16	23	42.0	4	4.0	56.0	40	145	460
74494.W0960	Silver	40	M16	23	42.0	4	4.0	56.0	50	145	472
74494.W0965	Silver	40	M16	23	42.0	4	4.0	56.0	63	145	491
74494.W0970	Silver	40	M16	23	42.0	4	4.0	56.0	80	145	513

CLAMPING LEVERS



74500

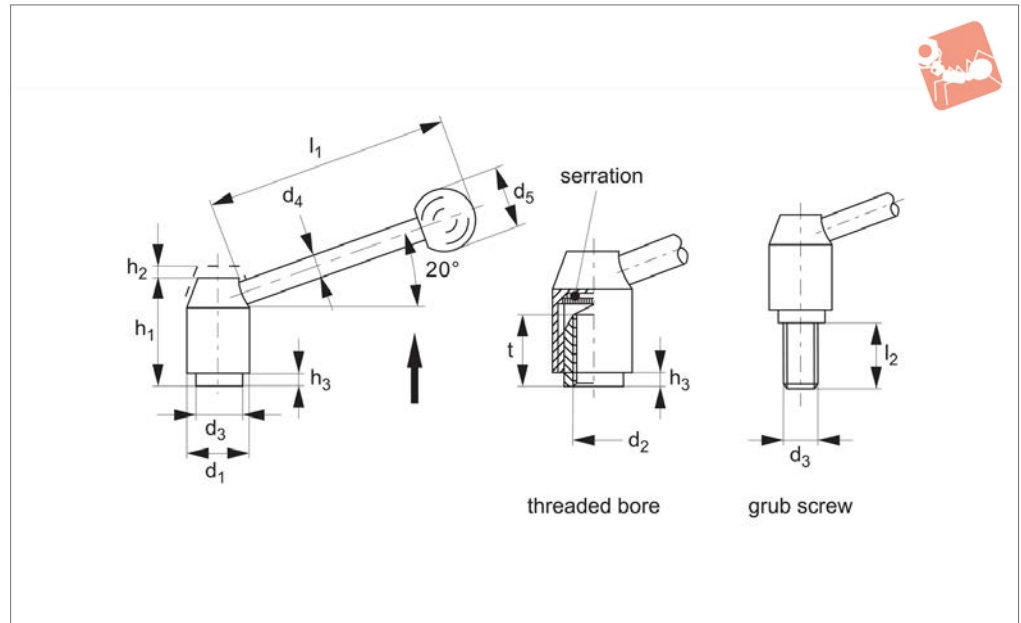

Material

Lever: free cutting steel, blackened.
Screw & inner parts: steel, quality 5.8, blackened.

Ball knob: DIN 319 plastic. (PF 31), black.

Technical Notes

By lifting up the lever, the serrations are

disengaged and the handle can then be swung to any position. On releasing the serrations are automatically re-engaged.

Order No.	Finish	d ₁	d ₂	d ₃	d ₄	d ₅	h ₁	h ₂	h ₃	l ₁ ≈	l ₂	t min.	Weight g
74500.W0101	Threaded Bore	21	M 6	13.5	8	20	33.5	4.0	1.0	70	-	11	91
74500.W0102	Threaded Bore	21	M 8	13.5	8	20	33.5	4.0	1.0	70	-	11	89
74500.W0201	Threaded Bore	24	M 8	16.0	10	25	40.0	4.5	2.5	96	-	14	159
74500.W0202	Threaded Bore	24	M10	16.0	10	25	40.0	4.5	2.5	96	-	14	153
74500.W0301	Threaded Bore	28	M10	19.0	12	30	48.5	4.5	4.5	110	-	17	255
74500.W0302	Threaded Bore	28	M12	19.0	12	30	48.5	4.5	4.5	110	-	17	248
74500.W0401	Threaded Bore	33	M12	23.0	12	32	55.0	5.5	6.0	124	-	23	361
74500.W0402	Threaded Bore	33	M16	23.0	12	32	55.0	5.5	6.0	124	-	23	347
74500.W0501	Threaded Bore	40	M16	30.0	14	35	68.0	5.5	6.0	138	-	36	622
74500.W0502	Threaded Bore	40	M20	30.0	14	35	68.0	5.5	6.0	138	-	36	599
74500.W0120	Grub Screw	21	M 8	13.5	8	20	33.5	4.0	1.0	70	12	-	98
74500.W0122	Grub Screw	21	M 8	13.5	8	20	33.5	4.0	1.0	70	16	-	99
74500.W0124	Grub Screw	21	M 8	13.5	8	20	33.5	4.0	1.0	70	20	-	103
74500.W0126	Grub Screw	21	M 8	13.5	8	20	33.5	4.0	1.0	70	25	-	102
74500.W0128	Grub Screw	21	M 8	13.5	8	20	33.5	4.0	1.0	70	32	-	105
74500.W0130	Grub Screw	21	M 8	13.5	8	20	33.5	4.0	1.0	70	40	-	112
74500.W0132	Grub Screw	21	M 8	13.5	8	20	33.5	4.0	1.0	70	50	-	109
74500.W0134	Grub Screw	21	M 8	13.5	8	20	33.5	4.0	1.0	70	63	-	114
74500.W0220	Grub Screw	24	M10	16.0	10	25	40.0	4.5	2.5	96	16	-	172
74500.W0222	Grub Screw	24	M10	16.0	10	25	40.0	4.5	2.5	96	20	-	173
74500.W0224	Grub Screw	24	M10	16.0	10	25	40.0	4.5	2.5	96	25	-	174
74500.W0226	Grub Screw	24	M10	16.0	10	25	40.0	4.5	2.5	96	32	-	177
74500.W0228	Grub Screw	24	M10	16.0	10	25	40.0	4.5	2.5	96	40	-	184
74500.W0230	Grub Screw	24	M10	16.0	10	25	40.0	4.5	2.5	96	50	-	185
74500.W0232	Grub Screw	24	M10	16.0	10	25	40.0	4.5	2.5	96	63	-	195
74500.W0234	Grub Screw	24	M10	16.0	10	25	40.0	4.5	2.5	96	80	-	205
74500.W0318	Grub Screw	28	M12	19.0	12	30	48.5	4.5	4.5	110	16	-	277
74500.W0320	Grub Screw	28	M12	19.0	12	30	48.5	4.5	4.5	110	20	-	282
74500.W0322	Grub Screw	28	M12	19.0	12	30	48.5	4.5	4.5	110	25	-	283
74500.W0324	Grub Screw	28	M12	19.0	12	30	48.5	4.5	4.5	110	32	-	287
74500.W0326	Grub Screw	28	M12	19.0	12	30	48.5	4.5	4.5	110	40	-	298
74500.W0328	Grub Screw	28	M12	19.0	12	30	48.5	4.5	4.5	110	50	-	302
74500.W0330	Grub Screw	28	M12	19.0	12	30	48.5	4.5	4.5	110	63	-	312
74500.W0332	Grub Screw	28	M12	19.0	12	30	48.5	4.5	4.5	110	80	-	320



Adjustable Clamping Levers



Order No.	Finish	d ₁	d ₂	d ₃	d ₄	d ₅	h ₁	h ₂	h ₃	l ₁ ≈	l ₂	t min.	Weight g
74500.W0422	Grub Screw	33	M16	23.0	12	32	55.0	5.5	6.0	124	32	-	422
74500.W0424	Grub Screw	33	M16	23.0	12	32	55.0	5.5	6.0	124	40	-	439
74500.W0426	Grub Screw	33	M16	23.0	12	32	55.0	5.5	6.0	124	50	-	446
74500.W0428	Grub Screw	33	M16	23.0	12	32	55.0	5.5	6.0	124	63	-	461
74500.W0430	Grub Screw	33	M16	23.0	12	32	55.0	5.5	6.0	124	80	-	486
74500.W0520	Grub Screw	40	M20	30.0	14	35	68.0	5.5	6.0	138	40	-	772
74500.W0522	Grub Screw	40	M20	30.0	14	35	68.0	5.5	6.0	138	50	-	792
74500.W0524	Grub Screw	40	M20	30.0	14	35	68.0	5.5	6.0	138	63	-	826
74500.W0526	Grub Screw	40	M20	30.0	14	35	68.0	5.5	6.0	138	80	-	859

CLAMPING LEVERS



74600

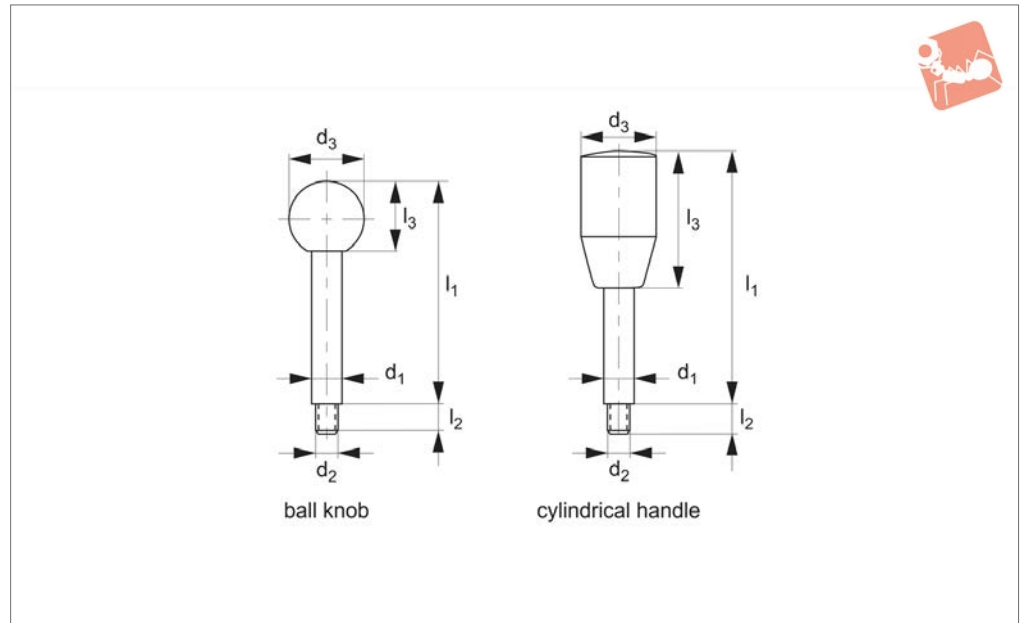

Material

Shafts: steel, galvanized, passivated or stainless steel 1.4305 (AISI 303) - matt

finish.

Temperature range 110°C.

Knobs: plastic, duroplast PF 31.

Technical Notes

Temperature range up to 110°C

Order No.	Type	d ₁	d ₂	d ₃	l ₁	l ₂	l ₃	Weight g
74600.W0020	Steel Shaft - Ball	8	M 6	20	63	9	18.0	30
74600.W0022	Steel Shaft - Ball	8	M 6	20	100	9	18.0	39
74600.W0025	Steel Shaft - Ball	10	M 8	25	80	11	22.5	50
74600.W0026	Steel Shaft - Ball	10	M 8	25	100	11	22.5	62
74600.W0027	Steel Shaft - Ball	10	M 8	25	125	11	22.5	76
74600.W0032	Steel Shaft - Ball	12	M10	32	100	14	29.0	96
74600.W0033	Steel Shaft - Ball	12	M10	32	125	14	29.0	118
74600.W0034	Steel Shaft - Ball	12	M10	32	160	14	29.0	146
74600.W0035	Steel Shaft - Ball	14	M12	35	125	16	32.5	157
74600.W0036	Steel Shaft - Ball	14	M12	35	160	16	32.5	203
74600.W0037	Steel Shaft - Ball	14	M12	35	200	16	32.5	251
74600.W0040	Steel Shaft - Ball	16	M14	40	160	18	37.0	310
74600.W0041	Steel Shaft - Ball	16	M14	40	200	18	37.0	326
74600.W0042	Steel Shaft - Ball	16	M14	40	250	18	37.0	397
74600.W0520	Stainless Shaft - Ball	8	M 6	20	63	9	18.0	30
74600.W0522	Stainless Shaft - Ball	8	M 6	20	100	9	18.0	44
74600.W0525	Stainless Shaft - Ball	10	M 8	25	80	11	22.5	55
74600.W0526	Stainless Shaft - Ball	10	M 8	25	100	11	22.5	63
74600.W0527	Stainless Shaft - Ball	10	M 8	25	125	11	22.5	78
74600.W0530	Stainless Shaft - Ball	12	M10	32	100	14	29.0	97
74600.W0531	Stainless Shaft - Ball	12	M10	32	125	14	29.0	120
74600.W0532	Stainless Shaft - Ball	12	M10	32	160	14	29.0	154
74600.W0535	Stainless Shaft - Ball	14	M12	35	125	16	32.5	159
74600.W0536	Stainless Shaft - Ball	14	M12	35	160	16	32.5	202
74600.W0537	Stainless Shaft - Ball	14	M12	35	200	16	32.5	250
74600.W0120	Steel Shaft - Taper	8	M 6	18	63	9	40.0	26
74600.W0122	Steel Shaft - Taper	8	M 6	18	100	9	40.0	42
74600.W0125	Steel Shaft - Taper	10	M 8	21	80	11	50.0	50
74600.W0126	Steel Shaft - Taper	10	M 8	21	100	11	50.0	62
74600.W0127	Steel Shaft - Taper	10	M 8	21	125	11	50.0	78
74600.W0130	Steel Shaft - Taper	12	M10	23	100	14	65.0	81
74600.W0131	Steel Shaft - Taper	12	M10	23	125	14	65.0	103
74600.W0132	Steel Shaft - Taper	12	M10	23	160	14	65.0	133
74600.W0135	Steel Shaft - Taper	14	M12	26	125	16	80.0	125



Gear Lever Handles

steel or stainless steel

Clamping Levers



Order No.	Type	d ₁	d ₂	d ₃	l ₁	l ₂	l ₃	Weight g
74600.W0136	Steel Shaft - Taper	14	M12	26	160	16	80.0	168
74600.W0137	Steel Shaft - Taper	14	M12	26	200	16	80.0	216
74600.W0140	Steel Shaft - Taper	16	M14	28	160	18	90.0	214
74600.W0141	Steel Shaft - Taper	16	M14	28	200	18	90.0	273
74600.W0142	Steel Shaft - Taper	16	M14	28	250	18	90.0	352
74600.W0620	Stainless Shaft - Taper	8	M 6	18	63	9	40.0	27
74600.W0622	Stainless Shaft - Taper	8	M 6	18	80	9	40.0	33
74600.W0624	Stainless Shaft - Taper	8	M 6	18	100	9	40.0	41
74600.W0630	Stainless Shaft - Taper	10	M 8	21	80	11	50.0	50
74600.W0632	Stainless Shaft - Taper	10	M 8	21	100	11	50.0	62
74600.W0634	Stainless Shaft - Taper	10	M 8	21	125	11	50.0	78
74600.W0640	Stainless Shaft - Taper	12	M10	23	100	14	65.0	81
74600.W0642	Stainless Shaft - Taper	12	M10	23	125	14	65.0	103
74600.W0644	Stainless Shaft - Taper	12	M10	23	160	14	65.0	133
74600.W0650	Stainless Shaft - Taper	14	M12	26	125	16	80.0	125
74600.W0652	Stainless Shaft - Taper	14	M12	26	160	16	80.0	168
74600.W0654	Stainless Shaft - Taper	14	M12	26	200	16	80.0	216

CLAMPING LEVERS



74700

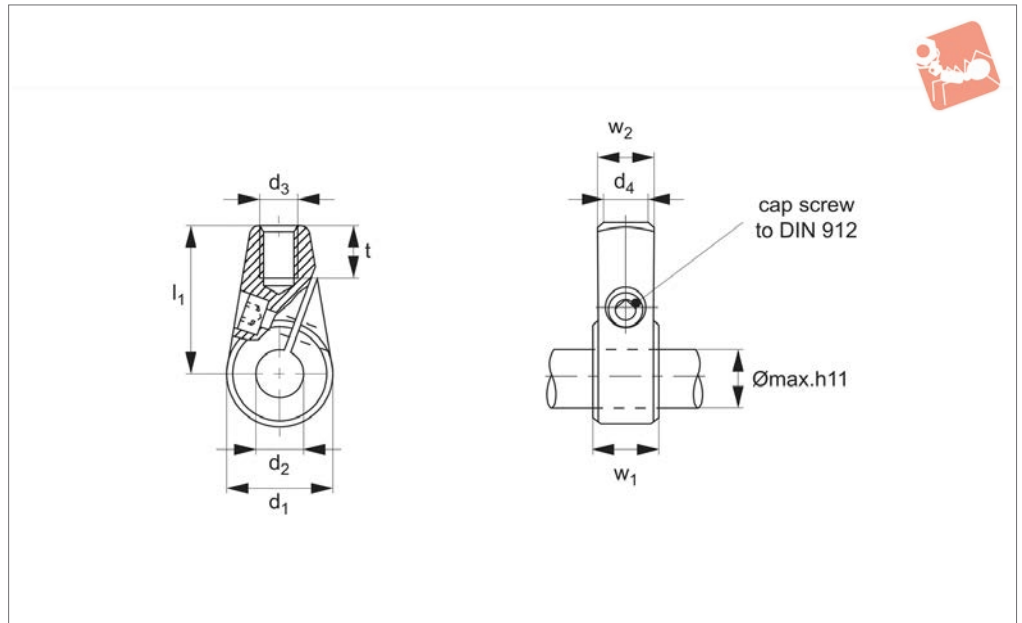

Material

Sintered steel.

machining. Eliminates clamping parts and assembly work.

Technical Notes

Ideal for mounting on shafts without prior

Order No.	d ₁	d ₂	Weight g	w ₁ ±0.2	w ₂	d ₃	d ₄	l ₁	t min.	Weight g
74700.W0024	24	10	64	15.5	13	M 8	10	36	11	64
74700.W0025	24	12	64	15.5	13	M 8	10	36	11	64
74700.W0029	28	14	94	17.5	15	M10	12	41	14	94
74700.W0033	32	16	137	19.5	17	M12	14	45	16	137



Adjustable Clamping Levers

threaded bore, inner parts **stainless steel**



Clamping Levers

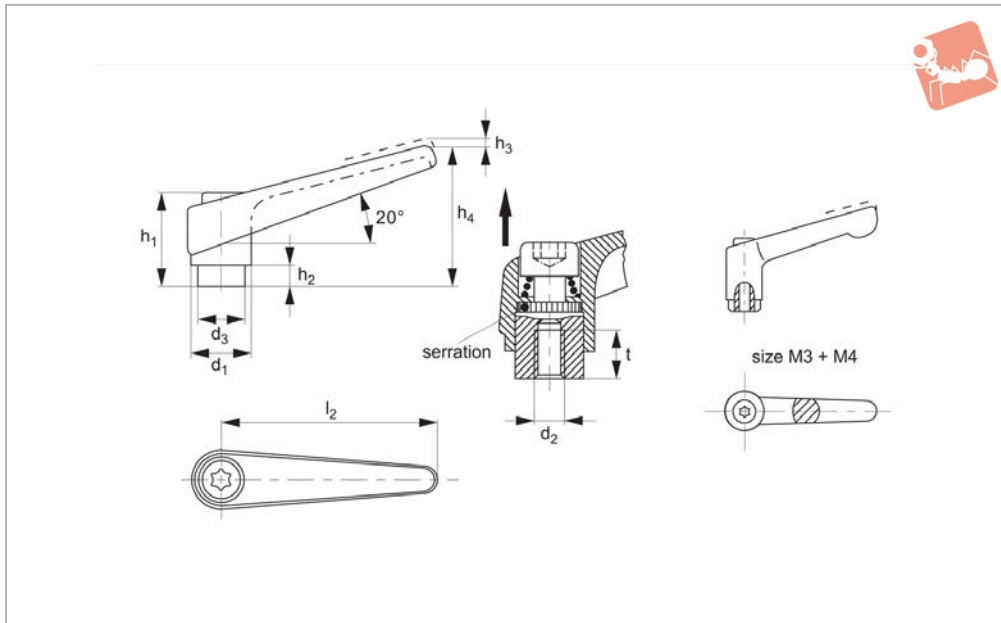

74440

CLAMPING LEVERS

Material

Handle: die-cast zinc,

- Orange RAL 2004

- Black RAL 9005

Inner parts: stainless steel 1,4305 (AISI 303).

Threaded part: stainless steel 1.4305.

(AISI 303).

Technical Notes

By lifting the lever, the serrations are disengaged. The handle can be positioned by the serrations, and the threaded insert can be exchanged. Upon releasing the

handle, the serrations are automatically re-engaged. The collar screw is torx head.

Tips

Suitable for medical and chemical industry applications.

Order No.	Colour	d ₁	d ₂	d ₃	h ₁	h ₂	h ₃	h ₄	l ₂	t ≤	Weight g
74440.W0032	Orange	13	M 3	10.0	24.5	4.0	3.5	30.5	30	7	25
74440.W0036	Orange	13	M 4	10.0	24.5	4.0	3.5	30.5	30	9	25
74440.W0111	Orange	14	M 5	10.0	24.5	4.0	3.0	35.0	45	8	33
74440.W0121	Orange	14	M 6	10.0	24.5	4.0	3.0	35.0	45	8	33
74440.W0321	Orange	18	M 8	13.5	31.0	6.5	3.0	45.0	62	10	67
74440.W0411	Orange	22	M 8	16.0	36.0	8.0	3.5	52.0	74	14	112
74440.W0421	Orange	22	M10	16.0	36.0	8.0	3.5	52.0	74	14	109
74440.W0511	Orange	25	M10	19.0	43.0	11.0	4.0	63.0	89	17	175
74440.W0521	Orange	25	M12	19.0	43.0	11.0	4.0	63.0	89	17	171
74440.W0611	Orange	30	M12	23.0	50.5	12.0	5.0	76.0	108	22	286
74440.W0621	Orange	30	M16	23.0	50.5	12.0	5.0	76.0	108	22	269
74440.W0034	Black	13	M 3	10.0	24.5	4.0	3.5	30.5	30	7	25
74440.W0038	Black	13	M 4	10.0	24.5	4.0	3.5	30.5	30	9	25
74440.W0114	Black	14	M 5	10.0	24.5	4.0	3.0	35.0	45	8	33
74440.W0124	Black	14	M 6	10.0	24.5	4.0	3.0	35.0	45	8	33
74440.W0324	Black	18	M 8	13.5	31.0	6.5	3.0	45.0	62	10	67
74440.W0414	Black	22	M 8	16.0	36.0	8.0	3.5	52.0	74	14	112
74440.W0424	Black	22	M10	16.0	36.0	8.0	3.5	52.0	74	14	109
74440.W0514	Black	25	M10	19.0	43.0	11.0	4.0	63.0	89	17	175
74440.W0524	Black	25	M12	19.0	43.0	11.0	4.0	63.0	89	17	171
74440.W0614	Black	30	M12	23.0	50.5	12.0	5.0	76.0	108	22	286
74440.W0624	Black	30	M16	23.0	50.5	12.0	5.0	76.0	108	22	269



74492

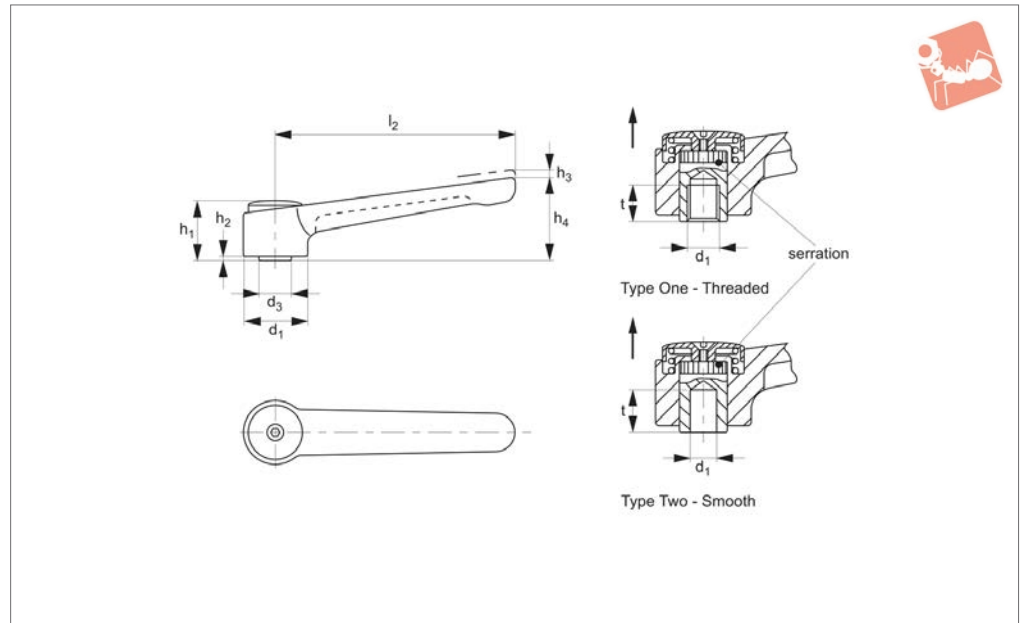

Material

Lever: Zinc die-cast, plastic coated, matt
 Black - similar to RAL 9005
 Silver - similar to RAL 9006
 Inner: Stainless steel
 Cover: Plastic.

Technical Notes

By lifting up the lever, the serrations are disengaged and the handle can then be swung to any position. On releasing the serrations are automatically re-engaged.

Available with smooth bore.

Tips

Suitable for use in restricted areas due to low height and adjustable lever.

Order No.	Type	d ₁	d ₂ tol. H7	d ₂	d ₃	h ₁	h ₂	h ₃	h ₄	l ₂	t min.	Weight g
74492.W0205	One, Black	32	16	M 8	16	29.5	2	2.5	41.5	120	14	187
74492.W0210	One, Black	32	16	M10	16	29.5	2	2.5	41.5	120	14	187
74492.W0215	One, Black	32	16	M12	16	29.5	2	2.5	41.5	120	14	187
74492.W0220	One, Black	40	23	M12	23	42.0	4	4.0	56.0	145	22	390
74492.W0225	One, Black	40	23	M16	23	42.0	4	4.0	56.0	145	22	373
74492.W0305	One, Silver	32	16	M 8	16	29.5	2	2.5	41.5	120	14	187
74492.W0310	One, Silver	32	16	M10	16	29.5	2	2.5	41.5	120	14	187
74492.W0315	One, Silver	32	16	M12	16	29.5	2	2.5	41.5	120	14	187
74492.W0320	One, Silver	40	23	M12	23	42.0	4	4.0	56.0	145	22	390
74492.W0325	One, Silver	40	23	M16	23	42.0	4	4.0	56.0	145	22	373
74492.W0250	Two, Black	32	8	-	16	29.5	2	2.5	41.5	120	14	185
74492.W0255	Two, Black	32	10	-	16	29.5	2	2.5	41.5	120	14	187
74492.W0260	Two, Black	40	12	-	23	42.0	4	4.0	56.0	145	22	390
74492.W0265	Two, Black	40	16	-	23	42.0	4	4.0	56.0	145	22	367
74492.W0350	Two, Silver	32	8	-	16	29.5	2	2.5	41.5	120	14	185
74492.W0355	Two, Silver	32	10	-	16	29.5	2	2.5	41.5	120	14	187
74492.W0360	Two, Silver	40	12	-	23	42.0	4	4.0	56.0	145	22	390
74492.W0365	Two, Silver	40	16	-	23	42.0	4	4.0	56.0	145	22	367



Adjustable Clamping Levers

cast zinc, inner parts stainless steel



Clamping Levers

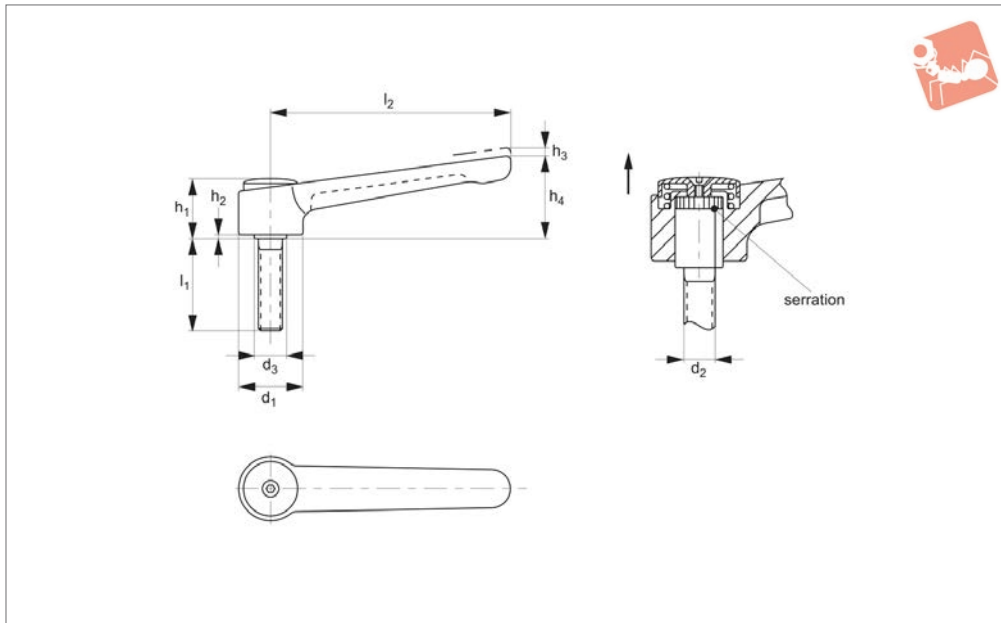

74496

CLAMPING LEVERS

Material

Lever: Zinc die-cast, plastic coated, matt
 Black - similar to RAL 9005
 Silver - similar to RAL 9006
 Inner: Stainless steel 1.4305
 Screw: Stainless steel 1.4305
 Cover: Plastic.

Technical Notes

By lifting up the lever, the serrations are disengaged and the handle can then be swung to any position. On releasing the serrations are automatically re-engaged.

Screw part can be changed.

Tips

Suitable for use in restricted areas due to low height and adjustable lever.

Order No.	Colour	l ₁	d ₁	d ₂	d ₃	h ₁	h ₂	h ₃	h ₄	l ₂	Weight g
74496.W0650	Black	20	32	M10	16	29.5	2	2.5	41.5	120	202
74496.W0655	Black	25	32	M10	16	29.5	2	2.5	41.5	120	204
74496.W0660	Black	32	32	M10	16	29.5	2	2.5	41.5	120	207
74496.W0665	Black	40	32	M10	16	29.5	2	2.5	41.5	120	212
74496.W0670	Black	50	32	M10	16	29.5	2	2.5	41.5	120	217
74496.W0680	Black	80	32	M10	16	29.5	2	2.5	41.5	120	231
74496.W0685	Black	20	32	M12	16	29.5	2	2.5	41.5	120	206
74496.W0690	Black	25	32	M12	16	29.5	2	2.5	41.5	120	210
74496.W0695	Black	32	32	M12	16	29.5	2	2.5	41.5	120	215
74496.W0700	Black	40	32	M12	16	29.5	2	2.5	41.5	120	221
74496.W0705	Black	50	32	M12	16	29.5	2	2.5	41.5	120	228
74496.W0710	Black	63	32	M12	16	29.5	2	2.5	41.5	120	237
74496.W0715	Black	80	32	M12	16	29.5	2	2.5	41.5	120	249
74496.W0725	Black	32	40	M12	23	42.0	4	4.0	56.0	145	432
74496.W0730	Black	40	40	M12	23	42.0	4	4.0	56.0	145	440
74496.W0735	Black	50	40	M12	23	42.0	4	4.0	56.0	145	447
74496.W0740	Black	63	40	M12	23	42.0	4	4.0	56.0	145	455
74496.W0745	Black	80	40	M12	23	42.0	4	4.0	56.0	145	445
74496.W0750	Black	32	40	M16	23	42.0	4	4.0	56.0	145	449
74496.W0755	Black	40	40	M16	23	42.0	4	4.0	56.0	145	460
74496.W0760	Black	50	40	M16	23	42.0	4	4.0	56.0	145	472
74496.W0765	Black	63	40	M16	23	42.0	4	4.0	56.0	145	491
74496.W0770	Black	80	40	M16	23	42.0	4	4.0	56.0	145	513
74496.W1650	Silver	20	32	M10	16	29.5	2	2.5	41.5	120	202
74496.W1655	Silver	25	32	M10	16	29.5	2	2.5	41.5	120	204
74496.W1660	Silver	32	32	M10	16	29.5	2	2.5	41.5	120	207
74496.W1665	Silver	40	32	M10	16	29.5	2	2.5	41.5	120	212
74496.W1670	Silver	50	32	M10	16	29.5	2	2.5	41.5	120	217
74496.W1680	Silver	80	32	M10	16	29.5	2	2.5	41.5	120	231
74496.W1685	Silver	20	32	M12	16	29.5	2	2.5	41.5	120	206
74496.W1690	Silver	25	32	M12	16	29.5	2	2.5	41.5	120	210



Order No.	Colour	l ₁	d ₁	d ₂	d ₃	h ₁	h ₂	h ₃	h ₄	l ₂	Weight g
74496.W1695	Silver	32	32	M12	16	29.5	2	2.5	41.5	120	215
74496.W1700	Silver	40	32	M12	16	29.5	2	2.5	41.5	120	221
74496.W1705	Silver	50	32	M12	16	29.5	2	2.5	41.5	120	228
74496.W1710	Silver	63	32	M12	16	29.5	2	2.5	41.5	120	237
74496.W1715	Silver	80	32	M12	16	29.5	2	2.5	41.5	120	249
74496.W1725	Silver	32	40	M12	23	42.0	4	4.0	56.0	145	432
74496.W1730	Silver	40	40	M12	23	42.0	4	4.0	56.0	145	440
74496.W1735	Silver	50	40	M12	23	42.0	4	4.0	56.0	145	447
74496.W1740	Silver	63	40	M12	23	42.0	4	4.0	56.0	145	455
74496.W1745	Silver	80	40	M12	23	42.0	4	4.0	56.0	145	445
74496.W1750	Silver	32	40	M16	23	42.0	4	4.0	56.0	145	449
74496.W1755	Silver	40	40	M16	23	42.0	4	4.0	56.0	145	460
74496.W1760	Silver	50	40	M16	23	42.0	4	4.0	56.0	145	472
74496.W1765	Silver	63	40	M16	23	42.0	4	4.0	56.0	145	491
74496.W1770	Silver	80	40	M16	23	42.0	4	4.0	56.0	145	513



Adjustable Clamping Levers

with grub screw, inner parts **stainless steel**

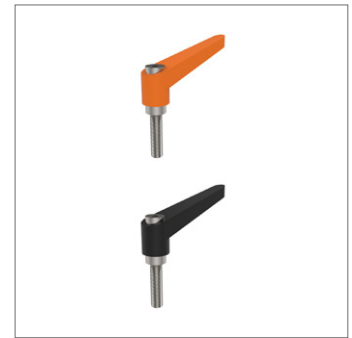
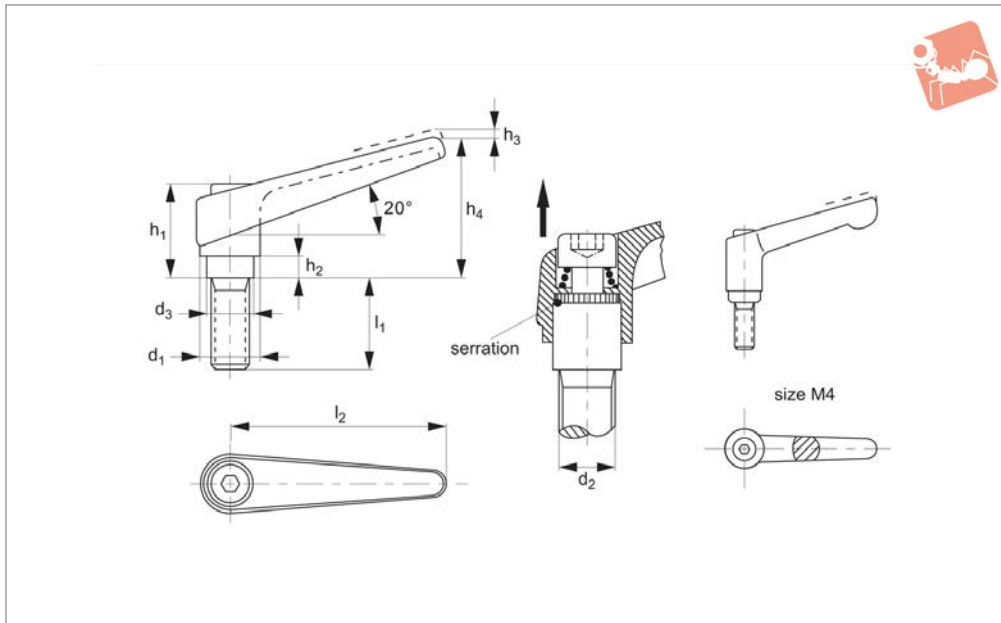

74460

CLAMPING LEVERS

Material

Handle: die-cast zinc,
 - Orange RAL 2004
 - Black RAL 9005.
 Inner parts: stainless steel 1.4305 (AISI 303).
 Screw: stainless steel 1.4305. (AISI 303).

Technical Notes

By lifting the lever, the serrations are disengaged. The handle can be positioned by the serrations, and the threaded insert can be exchanged. Upon releasing the handle, the serrations are automatically re-engaged.

Tips

Suitable for medical and chemical industry applications.

Order No.	Colour	l_1	d_1	d_2	d_3	h_1	h_2	h_3	h_4	l_2	Weight g
74460.W0010	Orange	12	13	M 4	10.0	24.5	4.0	3.5	30.5	30	27
74460.W0012	Black	12	13	M 4	10.0	24.5	4.0	3.5	30.5	30	27
74460.W0014	Orange	16	13	M 4	10.0	24.5	4.0	3.5	30.5	30	27
74460.W0016	Black	16	13	M 4	10.0	24.5	4.0	3.5	30.5	30	27
74460.W0018	Orange	20	13	M 4	10.0	24.5	4.0	3.5	30.5	30	27
74460.W0020	Black	20	13	M 4	10.0	24.5	4.0	3.5	30.5	30	27
74460.W0022	Orange	25	13	M 4	10.0	24.5	4.0	3.5	30.5	30	28
74460.W0024	Black	25	13	M 4	10.0	24.5	4.0	3.5	30.5	30	28
74460.W0026	Orange	32	13	M 4	10.0	24.5	4.0	3.5	30.5	30	28
74460.W0028	Black	32	13	M 4	10.0	24.5	4.0	3.5	30.5	30	28
74460.W0041	Orange	12	14	M 5	10.0	24.5	4.0	3.0	35.0	45	36
74460.W0044	Black	12	14	M 5	10.0	24.5	4.0	3.0	35.0	45	36
74460.W0051	Orange	16	14	M 5	10.0	24.5	4.0	3.0	35.0	45	36
74460.W0054	Black	16	14	M 5	10.0	24.5	4.0	3.0	35.0	45	36
74460.W0061	Orange	20	14	M 5	10.0	24.5	4.0	3.0	35.0	45	37
74460.W0064	Black	20	14	M 5	10.0	24.5	4.0	3.0	35.0	45	37
74460.W0071	Orange	25	14	M 5	10.0	24.5	4.0	3.0	35.0	45	38
74460.W0074	Black	25	14	M 5	10.0	24.5	4.0	3.0	35.0	45	38
74460.W0081	Orange	32	14	M 5	10.0	24.5	4.0	3.0	35.0	45	38
74460.W0084	Black	32	14	M 5	10.0	24.5	4.0	3.0	35.0	45	38
74460.W0086	Orange	40	14	M 5	10.0	24.5	4.0	3.0	35.0	45	39
74460.W0089	Black	40	14	M 5	10.0	24.5	4.0	3.0	35.0	45	39
74460.W0131	Orange	12	14	M 6	10.0	24.5	4.0	3.0	35.0	45	37
74460.W0134	Black	12	14	M 6	10.0	24.5	4.0	3.0	35.0	45	37
74460.W0141	Orange	16	14	M 6	10.0	24.5	4.0	3.0	35.0	45	37
74460.W0144	Black	16	14	M 6	10.0	24.5	4.0	3.0	35.0	45	37
74460.W0151	Orange	20	14	M 6	10.0	24.5	4.0	3.0	35.0	45	38
74460.W0154	Black	20	14	M 6	10.0	24.5	4.0	3.0	35.0	45	38
74460.W0161	Orange	25	14	M 6	10.0	24.5	4.0	3.0	35.0	45	39
74460.W0164	Black	25	14	M 6	10.0	24.5	4.0	3.0	35.0	45	39
74460.W0171	Orange	32	14	M 6	10.0	24.5	4.0	3.0	35.0	45	40



Order No.	Colour	l ₁	d ₁	d ₂	d ₃	h ₁	h ₂	h ₃	h ₄	l ₂	Weight g
74460.W0174	Black	32	14	M 6	10.0	24.5	4.0	3.0	35.0	45	40
74460.W0181	Orange	40	14	M 6	10.0	24.5	4.0	3.0	35.0	45	41
74460.W0184	Black	40	14	M 6	10.0	24.5	4.0	3.0	35.0	45	41
74460.W0191	Orange	50	14	M 6	10.0	24.5	4.0	3.0	35.0	45	43
74460.W0194	Black	50	14	M 6	10.0	24.5	4.0	3.0	35.0	45	43
74460.W0331	Orange	16	18	M 8	13.5	31.0	6.5	3.0	45.0	62	74
74460.W0334	Black	16	18	M 8	13.5	31.0	6.5	3.0	45.0	62	74
74460.W0341	Orange	20	18	M 8	13.5	31.0	6.5	3.0	45.0	62	76
74460.W0344	Black	20	18	M 8	13.5	31.0	6.5	3.0	45.0	62	76
74460.W0351	Orange	25	18	M 8	13.5	31.0	6.5	3.0	45.0	62	77
74460.W0354	Black	25	18	M 8	13.5	31.0	6.5	3.0	45.0	62	77
74460.W0361	Orange	32	18	M 8	13.5	31.0	6.5	3.0	45.0	62	79
74460.W0364	Black	32	18	M 8	13.5	31.0	6.5	3.0	45.0	62	79
74460.W0371	Orange	40	18	M 8	13.5	31.0	6.5	3.0	45.0	62	81
74460.W0374	Black	40	18	M 8	13.5	31.0	6.5	3.0	45.0	62	81
74460.W0381	Orange	50	18	M 8	13.5	31.0	6.5	3.0	45.0	62	84
74460.W0384	Black	50	18	M 8	13.5	31.0	6.5	3.0	45.0	62	84
74460.W0391	Orange	63	18	M 8	13.5	31.0	6.5	3.0	45.0	62	89
74460.W0394	Black	63	18	M 8	13.5	31.0	6.5	3.0	45.0	62	89
74460.W0441	Orange	20	22	M10	16.0	36.0	8.0	3.5	52.0	74	128
74460.W0444	Black	20	22	M10	16.0	36.0	8.0	3.5	52.0	74	128
74460.W0451	Orange	25	22	M10	16.0	36.0	8.0	3.5	52.0	74	130
74460.W0454	Black	25	22	M10	16.0	36.0	8.0	3.5	52.0	74	130
74460.W0461	Orange	32	22	M10	16.0	36.0	8.0	3.5	52.0	74	134
74460.W0464	Black	32	22	M10	16.0	36.0	8.0	3.5	52.0	74	134
74460.W0471	Orange	40	22	M10	16.0	36.0	8.0	3.5	52.0	74	138
74460.W0474	Black	40	22	M10	16.0	36.0	8.0	3.5	52.0	74	138
74460.W0481	Orange	50	22	M10	16.0	36.0	8.0	3.5	52.0	74	143
74460.W0484	Black	50	22	M10	16.0	36.0	8.0	3.5	52.0	74	143
74460.W0486	Orange	63	22	M10	16.0	36.0	8.0	3.5	52.0	74	148
74460.W0489	Black	63	22	M10	16.0	36.0	8.0	3.5	52.0	74	148
74460.W0491	Orange	80	22	M10	16.0	36.0	8.0	3.5	52.0	74	157
74460.W0494	Black	80	22	M10	16.0	36.0	8.0	3.5	52.0	74	157
74460.W0541	Orange	25	25	M12	19.0	43.0	11.0	4.0	63.0	89	205
74460.W0544	Black	25	25	M12	19.0	43.0	11.0	4.0	63.0	89	205
74460.W0551	Orange	32	25	M12	19.0	43.0	11.0	4.0	63.0	89	209
74460.W0554	Black	32	25	M12	19.0	43.0	11.0	4.0	63.0	89	209
74460.W0561	Orange	40	25	M12	19.0	43.0	11.0	4.0	63.0	89	215
74460.W0564	Black	40	25	M12	19.0	43.0	11.0	4.0	63.0	89	215
74460.W0571	Orange	50	25	M12	19.0	43.0	11.0	4.0	63.0	89	222
74460.W0574	Black	50	25	M12	19.0	43.0	11.0	4.0	63.0	89	222
74460.W0581	Orange	63	25	M12	19.0	43.0	11.0	4.0	63.0	89	232
74460.W0584	Black	63	25	M12	19.0	43.0	11.0	4.0	63.0	89	232
74460.W0591	Orange	80	25	M12	19.0	43.0	11.0	4.0	63.0	89	244
74460.W0594	Black	80	25	M12	19.0	43.0	11.0	4.0	63.0	89	244
74460.W0641	Orange	32	30	M16	23.0	50.5	12.0	5.0	76.0	108	348
74460.W0644	Black	32	30	M16	23.0	50.5	12.0	5.0	76.0	108	348
74460.W0651	Orange	40	30	M16	23.0	50.5	12.0	5.0	76.0	108	357
74460.W0654	Black	40	30	M16	23.0	50.5	12.0	5.0	76.0	108	357
74460.W0661	Orange	50	30	M16	23.0	50.5	12.0	5.0	76.0	108	370
74460.W0664	Black	50	30	M16	23.0	50.5	12.0	5.0	76.0	108	370
74460.W0671	Orange	63	30	M16	23.0	50.5	12.0	5.0	76.0	108	386
74460.W0674	Black	63	30	M16	23.0	50.5	12.0	5.0	76.0	108	386
74460.W0681	Orange	80	30	M16	23.0	50.5	12.0	5.0	76.0	108	407
74460.W0684	Black	80	30	M16	23.0	50.5	12.0	5.0	76.0	108	407



Adjustable Clamping Lever

threaded bore - stainless

Clamping Levers

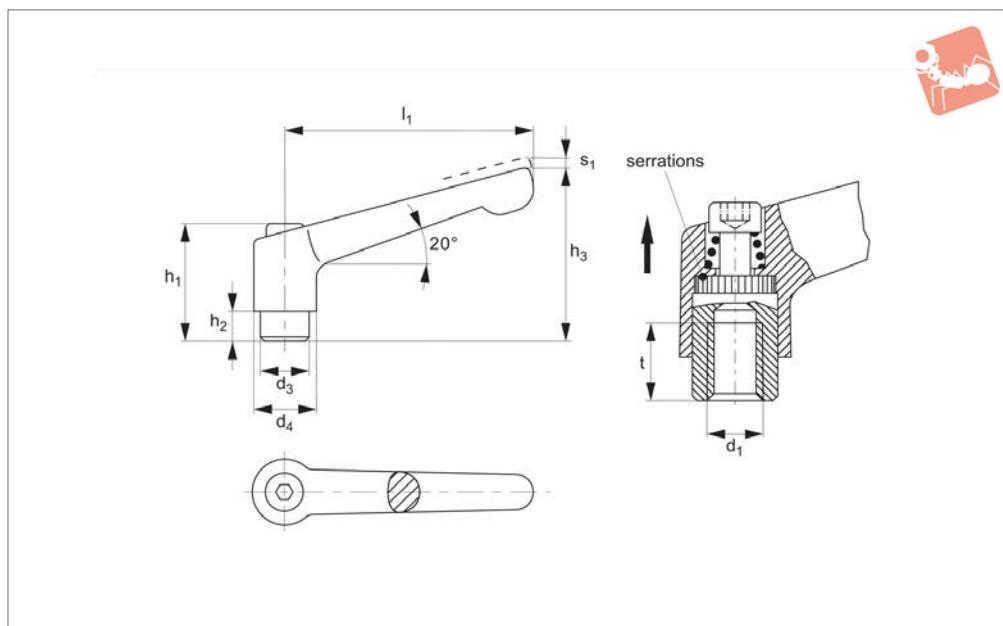

74380

CLAMPING LEVERS

Material

Stainless steel, 1.4308 (AISI CF-8). Matte blasted.

Inner parts: stainless, 1.4305.

Screw & spring: stainless, 1.4300.

disengaged. The handle can be positioned by the serrations, and the threaded insert can be exchanged. Upon releasing the handle, the serrations are automatically re-engaged.

ronments, such as food processing, chemical industries etc.

Technical Notes

By lifting the lever, the serrations are

Tips

Ideal for applications with aggressive envi-

Order No.	l_1	d_1	d_3	d_4	h_1	h_2	h_3	t min.	Stroke s_1	Weight g
74380.W0111	45	M 5	10.0	13.0	24.5	4.0	35	9	3.5	37
74380.W0121	45	M 6	10.0	13.0	24.5	4.0	35	9	3.5	30
74380.W0311	63	M 6	13.5	17.5	31.0	6.5	45	11	4.0	80
74380.W0321	63	M 8	13.5	17.5	31.0	6.5	45	11	4.0	50
74380.W0411	78	M 8	16.0	21.0	36.0	8.0	55	14	4.0	140
74380.W0421	78	M10	16.0	21.0	36.0	8.0	55	14	4.0	140



74520

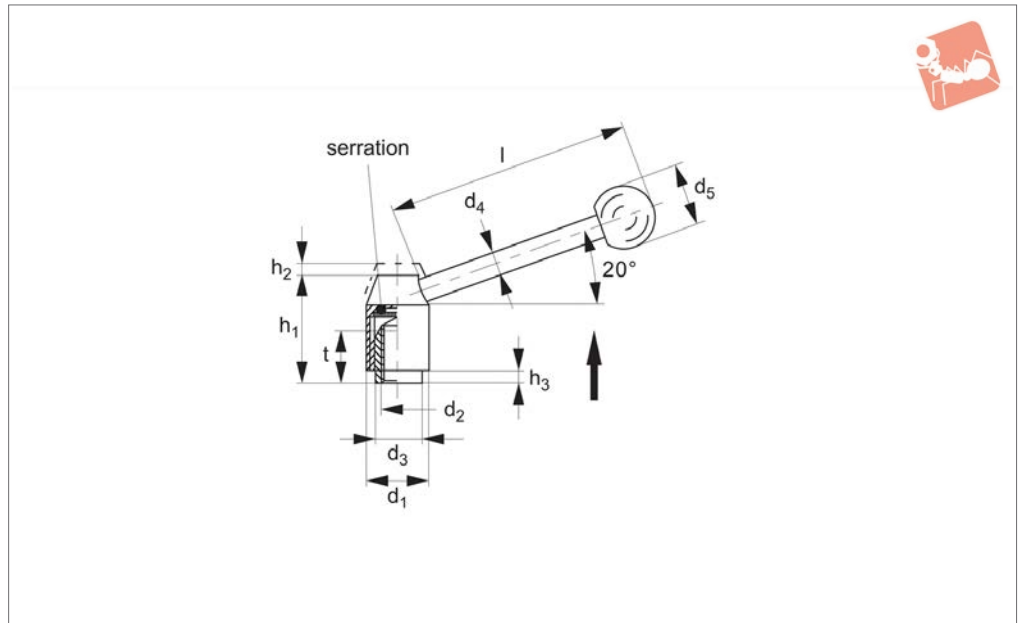

CLAMPING LEVERS

Material

Stainless steel no. 1.4305 (AISI 303), matt shot-blasted. Ball knob DIN 319, plastic black.

Technical Notes

Ideal whenever parts have to be clamped in

a confined space or a particular lever position is required. Pulling the lever, disengages the serrations allowing it to be swivelled to the ideal clamping position. On releasing the lever it will automatically re-engage.

Order No.	d ₁	d ₂	d ₃	d ₄	d ₅	h ₁	h ₂	h ₃	l	t min.	Weight g
74520.W0006	21	M 6	13.5	8	20	33.5	4.0	1.0	70	11	91
74520.W0007	21	M 8	13.5	8	20	33.5	4.0	1.0	70	11	89
74520.W0008	24	M 8	16.0	10	25	40.0	4.5	2.5	96	14	159
74520.W0009	24	M10	16.0	10	25	40.0	4.5	2.5	96	14	153
74520.W0010	28	M10	19.0	12	30	48.5	4.5	4.5	110	17	255
74520.W0012	28	M12	19.0	12	30	48.5	4.5	4.5	110	17	248



Adjustable Clamping Lever

stainless steel - grub screw

Clamping Levers

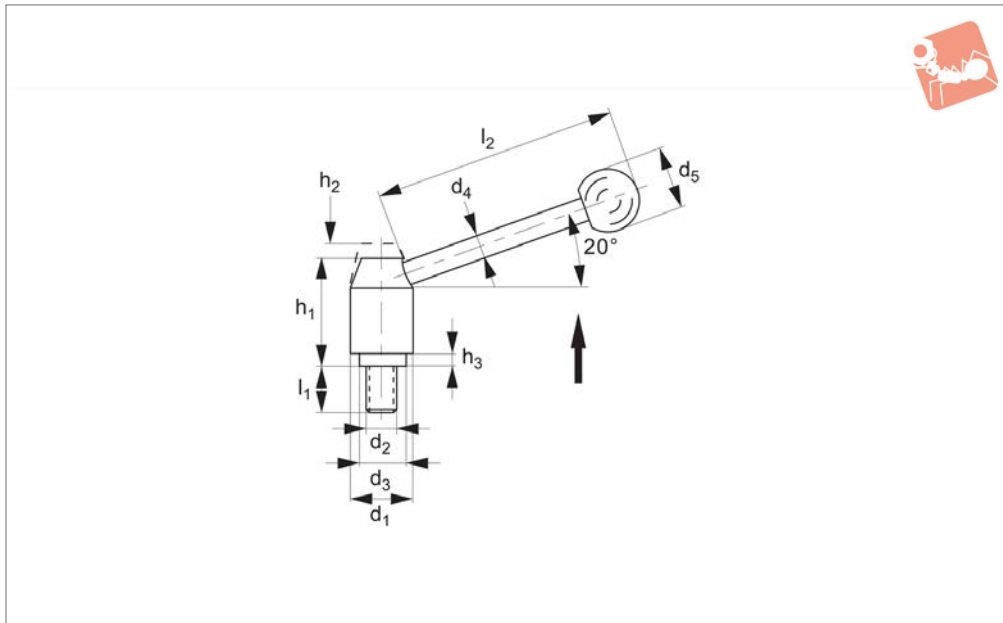

74530

CLAMPING LEVERS

Material

Stainless steel no. 1.4305 (AISI 303), matt shot-blasted. Ball knob DIN 319, plastic black.

Technical Notes

Ideal whenever parts have to be clamped in

a confined space or a particular lever position is required. Pulling the lever, disengages the serrations allowing it to be swivelled to the ideal clamping position. On releasing the lever it will automatically re-engage.

Order No.	l_1	d_1	d_2	d_3	d_4	d_5	h_1	h_2 stroke	h_3	$l_2 \approx$	Weight g
74530.W0080	16	21	M 8	13.5	8	20	33.5	4.0	1.0	70	99
74530.W0081	20	21	M 8	13.5	8	20	33.5	4.0	1.0	70	103
74530.W0082	25	21	M 8	13.5	8	20	33.5	4.0	1.0	70	102
74530.W0083	32	21	M 8	13.5	8	20	33.5	4.0	1.0	70	105
74530.W0084	40	21	M 8	13.5	8	20	33.5	4.0	1.0	70	112
74530.W0085	50	21	M 8	13.5	8	20	33.5	4.0	1.0	70	109
74530.W0086	63	21	M 8	13.5	8	20	33.5	4.0	1.0	70	114
74530.W0100	20	24	M10	16.0	10	25	40.0	4.5	2.5	96	173
74530.W0101	25	24	M10	16.0	10	25	40.0	4.5	2.5	96	174
74530.W0102	32	24	M10	16.0	10	25	40.0	4.5	2.5	96	177
74530.W0103	40	24	M10	16.0	10	25	40.0	4.5	2.5	96	184
74530.W0104	50	24	M10	16.0	10	25	40.0	4.5	2.5	96	185
74530.W0105	63	24	M10	16.0	10	25	40.0	4.5	2.5	96	195
74530.W0106	80	24	M10	16.0	10	25	40.0	4.5	2.5	96	205
74530.W0120	25	28	M12	19.0	12	30	48.5	4.5	4.5	110	283
74530.W0121	32	28	M12	19.0	12	30	48.5	4.5	4.5	110	287
74530.W0122	40	28	M12	19.0	12	30	48.5	4.5	4.5	110	298
74530.W0123	50	28	M12	19.0	12	30	48.5	4.5	4.5	110	302
74530.W0124	63	28	M12	19.0	12	30	48.5	4.5	4.5	110	312
74530.W0125	80	28	M12	19.0	12	30	48.5	4.5	4.5	110	320



74960

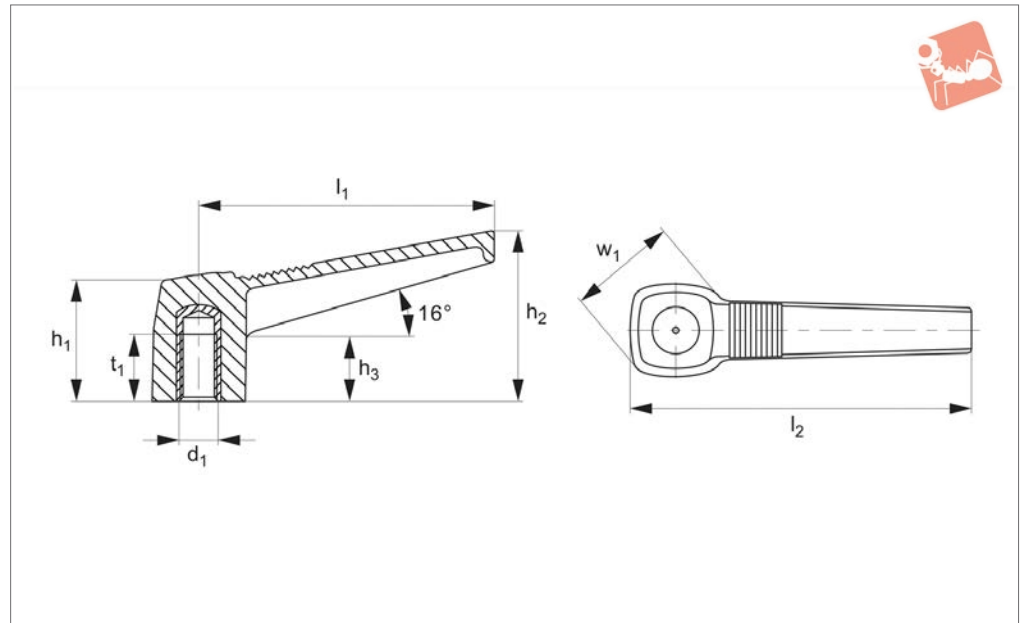

Material

Matt black, thermoplastic, glass fibre reinforced. Brass insert.

Technical Notes

Special size and colours available on request, subject to minimum order quantity.

tity.

Order No.	l_1	d_1	h_1	h_2	h_3	l_2	t_1	w_1	Weight g
74960.W0041	42	M 5	20	25	11	50	9	19	8
74960.W0042	42	M 6	20	25	11	50	9	19	8
74960.W0063	63	M 6	26	35	14	73	13	25	20
74960.W0064	63	M 8	26	35	14	73	13	25	20
74960.W0080	80	M 8	33	45	17	92	15	30	37
74960.W0081	80	M10	33	45	17	92	16	30	38
74960.W0082	80	M12	39	45	17	92	18	30	33
74960.W0100	100	M12	39	55	18	115	18	36	68
74960.W0101	100	M14	39	55	18	36	20	115	72
74960.W0102	100	M16	39	55	18	115	20	36	76

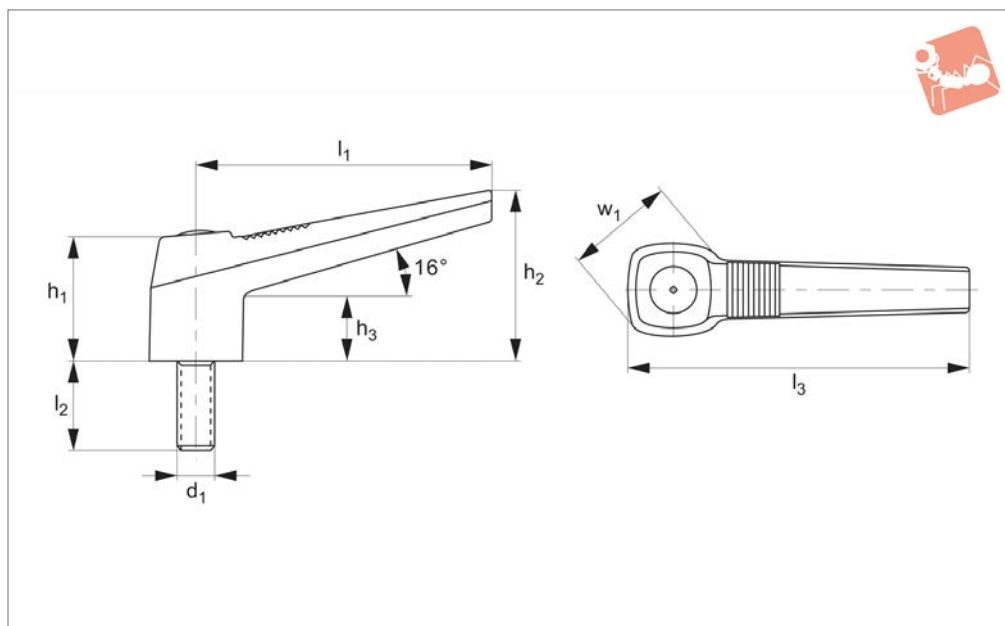

74970

CLAMPING LEVERS

Material

Thermoplastic, black, matt, glass fibre reinforced. Zinc plated steel stud.

Technical Notes

Special size and colours available on request, subject to minimum order quantity.

tity.

Order No.	l_1	d_1	h_1	h_2	h_3	l_2	l_3	w_1	Weight g
74970.W0041	42	M 6	20	25	11	15	50	19	11
74970.W0042	42	M 6	20	25	11	20	50	19	12
74970.W0063	63	M 8	26	35	14	25	73	25	30
74970.W0080	80	M 8	33	45	17	20	92	30	52
74970.W0081	80	M10	33	45	17	30	92	30	57
74970.W0100	100	M12	39	55	18	50	115	36	121



74390

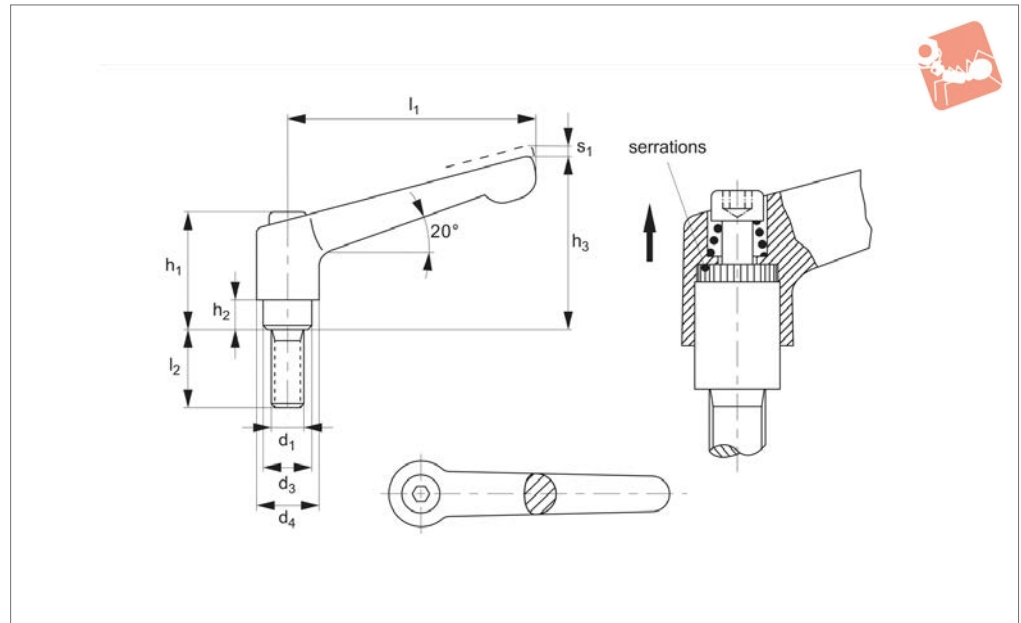

Material

Stainless steel, 1.4308 (AISI CF-8). Matte blasted.

Inner parts: stainless, 1.4305.

Screw & spring: stainless, 1.4300.

disengaged. The handle can be positioned by the serrations, and the threaded insert can be exchanged. Upon releasing the handle, the serrations are automatically re-engaged.

ronments, such as food processing, chemical industries etc.

Technical Notes

By lifting the lever, the serrations are

Tips

Ideal for applications with aggressive envi-

Order No.	l_1	d_1	d_3	d_4	h_1	h_2	h_3	l_2	Stroke s_1
74390.W0041	45	M 5	10.0	13.0	24.5	4.0	35	12	3.5
74390.W0051	45	M 5	10.0	13.0	24.5	4.0	35	16	3.5
74390.W0061	45	M 5	10.0	13.0	24.5	4.0	35	20	3.5
74390.W0071	45	M 5	10.0	13.0	24.5	4.0	35	25	3.5
74390.W0081	45	M 5	10.0	13.0	24.5	4.0	35	32	3.5
74390.W0091	45	M 5	10.0	13.0	24.5	4.0	35	40	3.5
74390.W0099	45	M 5	10.0	13.0	24.5	4.0	35	50	3.5
74390.W0141	45	M 6	10.0	13.0	24.5	4.0	35	12	3.5
74390.W0151	45	M 6	10.0	13.0	24.5	4.0	35	16	3.5
74390.W0161	45	M 6	10.0	13.0	24.5	4.0	35	20	3.5
74390.W0171	45	M 6	10.0	13.0	24.5	4.0	35	25	3.5
74390.W0181	45	M 6	10.0	13.0	24.5	4.0	35	32	3.5
74390.W0191	45	M 6	10.0	13.0	24.5	4.0	35	40	3.5
74390.W0199	45	M 6	10.0	13.0	24.5	4.0	35	50	3.5
74390.W0221	63	M 6	13.5	17.5	31.0	6.5	45	16	4.0
74390.W0231	63	M 6	13.5	17.5	31.0	6.5	45	20	4.0
74390.W0241	63	M 6	13.5	17.5	31.0	6.5	45	25	4.0
74390.W0251	63	M 6	13.5	17.5	31.0	6.5	45	32	4.0
74390.W0261	63	M 6	13.5	17.5	31.0	6.5	45	40	4.0
74390.W0271	63	M 6	13.5	17.5	31.0	6.5	45	50	4.0
74390.W0281	63	M 6	13.5	17.5	31.0	6.5	45	63	4.0
74390.W0331	63	M 8	13.5	17.5	31.0	6.5	45	16	4.0
74390.W0341	63	M 8	13.5	17.5	31.0	6.5	45	20	4.0
74390.W0351	63	M 8	13.5	17.5	31.0	6.5	45	25	4.0
74390.W0361	63	M 8	13.5	17.5	31.0	6.5	45	32	4.0
74390.W0371	63	M 8	13.5	17.5	31.0	6.5	45	40	4.0
74390.W0381	63	M 8	13.5	17.5	31.0	6.5	45	50	4.0
74390.W0391	63	M 8	13.5	17.5	31.0	6.5	45	63	4.0
74390.W0441	78	M 8	16.0	21.0	36.0	8.0	55	20	4.0
74390.W0451	78	M 8	16.0	21.0	36.0	8.0	55	25	4.0
74390.W0461	78	M 8	16.0	21.0	36.0	8.0	55	32	4.0



Adjustable Clamping Levers

with grub screw - stainless



Order No.	l_1	d_1	d_3	d_4	h_1	h_2	h_3	l_2	Stroke s_1
74390.W0471	78	M 8	16.0	21.0	36.0	8.0	55	40	4.0
74390.W0481	78	M 8	16.0	21.0	36.0	8.0	55	50	4.0
74390.W0491	78	M 8	16.0	21.0	36.0	8.0	55	63	4.0
74390.W0499	78	M 8	16.0	21.0	36.0	8.0	55	80	4.0
74390.W0541	78	M10	16.0	21.0	36.0	8.0	55	20	4.0
74390.W0551	78	M10	16.0	21.0	36.0	8.0	55	25	4.0
74390.W0561	78	M10	16.0	21.0	36.0	8.0	55	32	4.0
74390.W0571	78	M10	16.0	21.0	36.0	8.0	55	40	4.0
74390.W0581	78	M10	16.0	21.0	36.0	8.0	55	50	4.0
74390.W0591	78	M10	16.0	21.0	36.0	8.0	55	63	4.0
74390.W0599	78	M10	16.0	21.0	36.0	8.0	55	80	4.0

CLAMPING LEVERS



73920

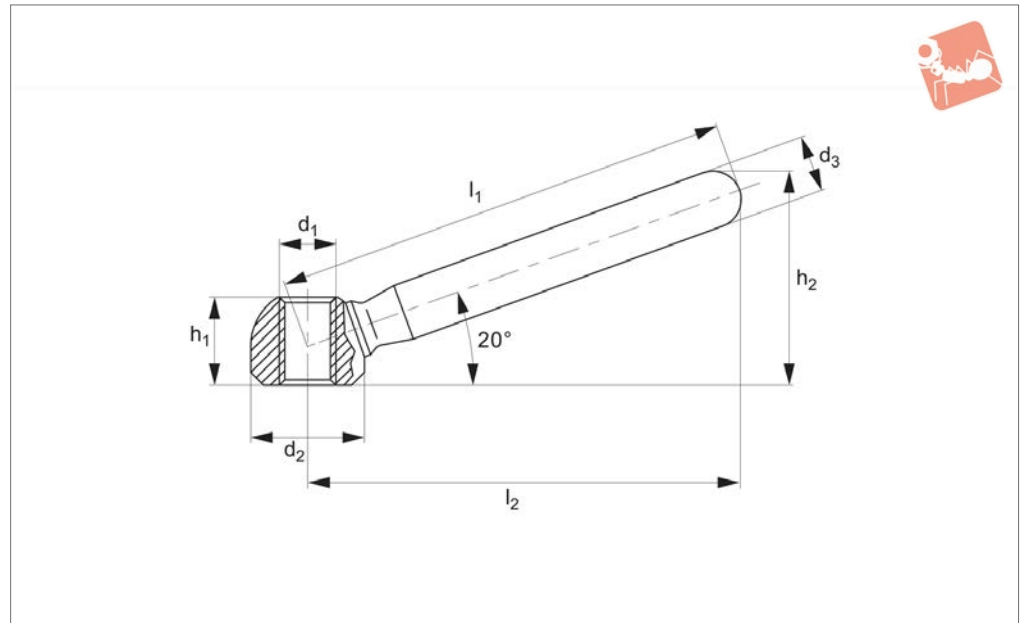

Material

Case hardened steel, or stainless steel AISI 303. Shaft butt welded.

Technical Notes

Low price version to no. 74200.

Order No.	Finish	d ₁	d ₂	d ₃	h ₁	h ₂ ≈	l ₁	l ₂ ≈	Weight g
73920.W0506	Steel	M 8	16	10	12.5	30.5	63	60	39
73920.W0508	Steel	M10	20	12	15.0	37.0	80	76	74
73920.W0510	Steel	M12	25	14	19.0	46.0	100	95	149
73920.W0512	Steel	M16	32	18	25.0	58.5	125	119	316
73920.W0516	Steel	M20	40	20	31.0	73.0	160	152	533
73920.W0606	Stainless Steel	M 8	16	10	12.5	30.5	63	60	39
73920.W0608	Stainless Steel	M10	20	12	15.0	37.0	80	76	73
73920.W0610	Stainless Steel	M12	25	14	19.0	46.0	100	95	153
73920.W0612	Stainless Steel	M16	32	18	25.0	58.5	125	119	314
73920.W0616	Stainless Steel	M20	40	20	31.0	73.0	160	152	533



Clamping Nuts welded, double-sided

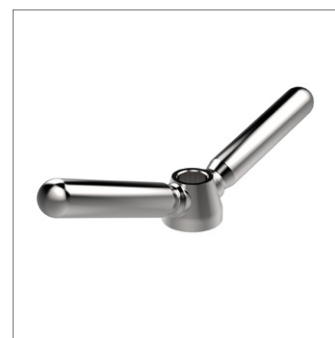
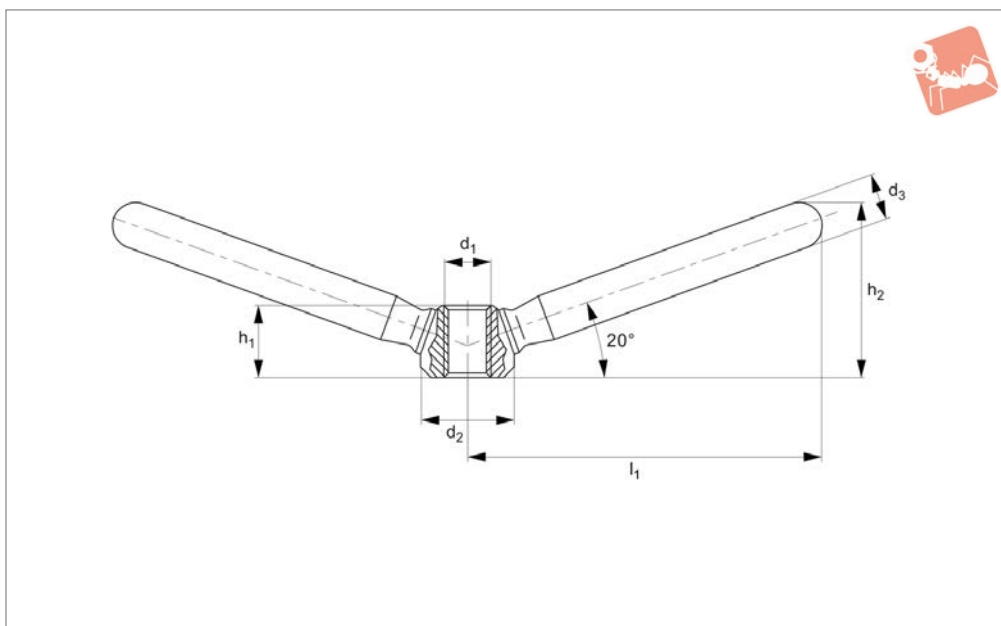

73922

CLAMPING LEVERS

Material

Steel, galvanised.
Stainless steel 1.4301, dull blasted.

Technical Notes

Allows for two-handed operating.

Order No.	Material	d ₁	d ₂	d ₃	h ₁	h ₂	l ₁ ≈	Weight g
73922.W0706	Steel	M 8	16	10	12.5	26	47.5	55
73922.W0708	Steel	M10	20	12	15.0	32	59.5	116
73922.W0710	Steel	M12	25	14	19.0	40	75.5	210
73922.W0712	Steel	M16	32	18	25.0	52	94.5	432
73922.W0716	Steel	M20	40	20	31.0	62	118.0	716
73922.W0806	Stainless Steel	M 8	16	10	12.5	26	47.5	55
73922.W0808	Stainless Steel	M10	20	12	15.0	32	59.5	116
73922.W0810	Stainless Steel	M12	25	14	19.0	40	75.5	210
73922.W0812	Stainless Steel	M16	32	18	25.0	52	94.5	432
73922.W0816	Stainless Steel	M20	40	20	31.0	62	118.0	716



74000

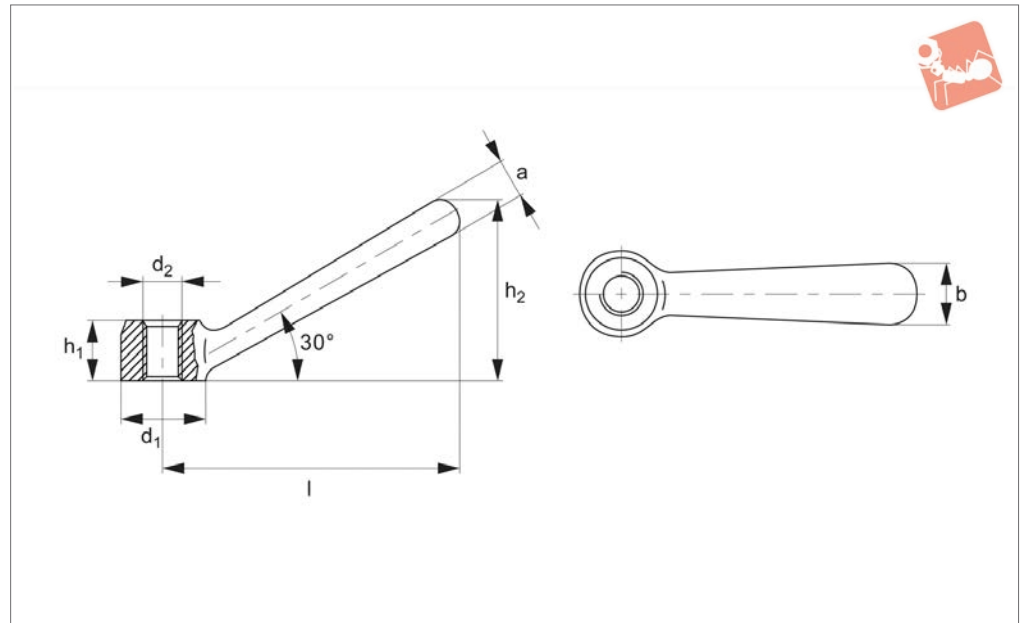

Material

Malleable iron, tumble finish. Contact faces machined.

Technical Notes

These economic clamping levers are ideal where a lacquered finish is required.

Order No.	a	b	d ₁	d ₂	h ₁	h ₂ ≈	l ≈	Weight g
74000.W0008	7	12	16	M 8	12	34.0	56	34
74000.W0010	9	14	20	M10	14	42.5	70	60
74000.W0012	11	18	25	M12	18	53.0	87	125
74000.W0016	15	22	32	M16	22	66.5	109	248
74000.W0020	18	28	40	M20	28	84.5	140	518

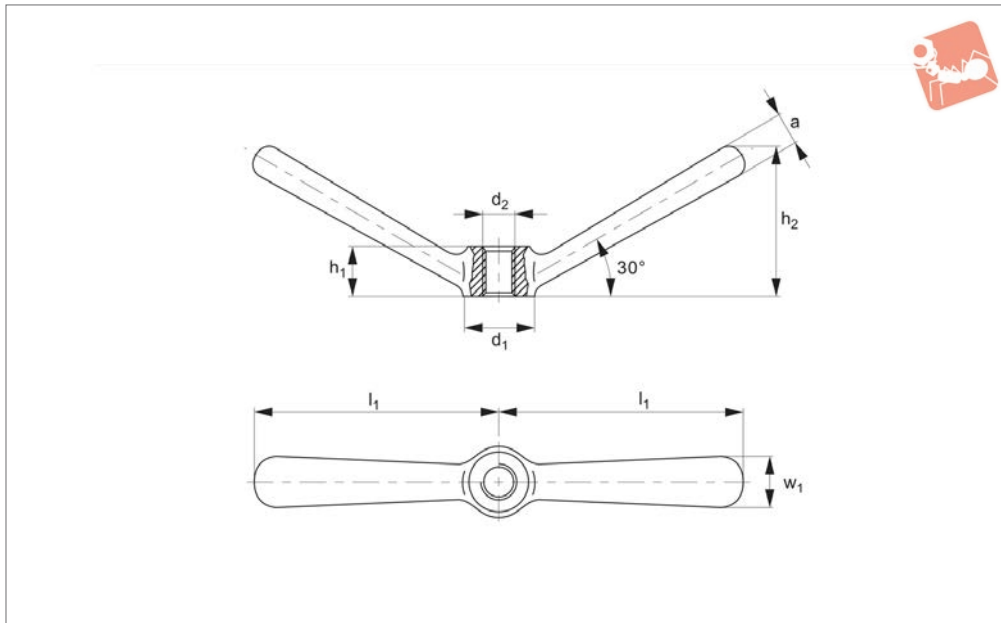

74100

CLAMPING LEVERS

Material

Malleable iron, prepared and tumble finished. Contact faces machined.

Technical Notes

Clamping levers with double arms are robust. Applications are, for example, in

boiler making and special purpose machinery.

Order No.	a	d ₁	d ₂	h ₁	h ₂ ≈	l ₁ ≈	w ₁	Weight g
74100.W0008	7	16	M 8	12	34	56	12	55
74100.W0010	9	20	M10	14	42	70	14	104
74100.W0012	11	25	M12	18	53	87	18	213
74100.W0016	15	32	M16	22	66	109	22	429
74100.W0020	18	40	M20	28	84	140	28	820



74200

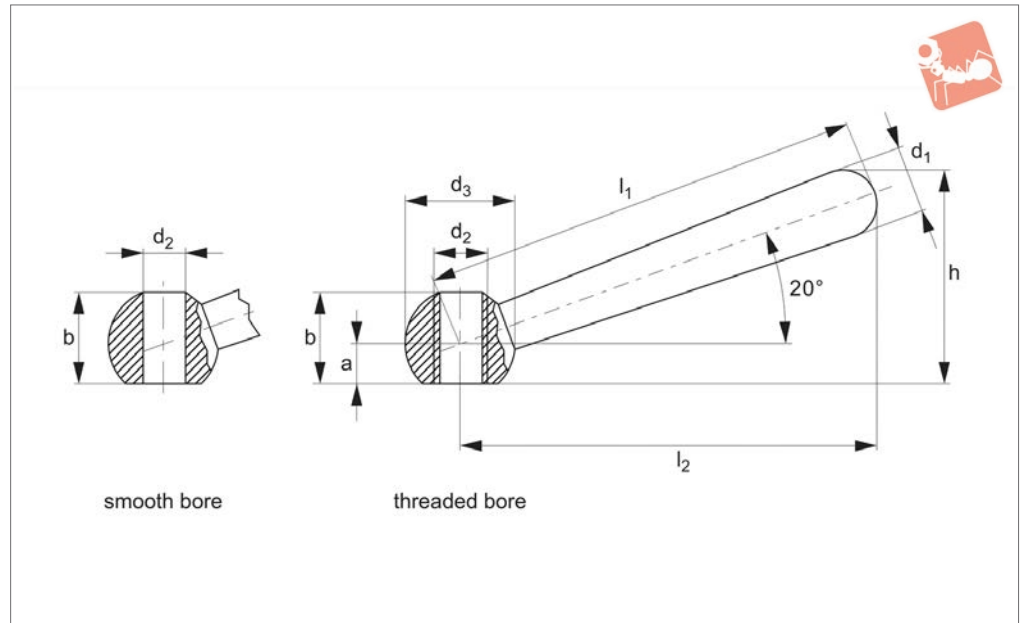

Material

Steel, blackened.

Order No.	Finish	a	b	d_1	d_2 tol. H7	d_2	d_3	h	l_1	l_2	Weight g
74200.W0105	Smooth Bore	4.0	9.5	8	6	-	12	24.0	50	48	16
74200.W0106	Smooth Bore	5.0	12.0	10	8	-	16	30.5	63	60	37
74200.W0108	Smooth Bore	6.0	14.5	13	10	-	20	38.0	80	76	73
74200.W0110	Smooth Bore	7.5	18.5	16	12	-	25	47.0	100	95	140
74200.W0112	Smooth Bore	10.0	24.0	20	16	-	32	59.5	125	119	282
74200.W0116	Smooth Bore	12.5	30.0	25	20	-	40	75.7	160	152	553
74200.W0120	Smooth Bore	18.0	40.0	32	24	-	50	97.0	200	190	1096
74200.W0305	Threaded Bore	4.0	9.5	8	-	M 6	12	24.0	50	48	17
74200.W0306	Threaded Bore	5.0	12.5	10	-	M 8	16	30.5	63	60	38
74200.W0308	Threaded Bore	6.0	15.0	13	-	M10	20	38.0	80	76	74
74200.W0310	Threaded Bore	7.5	19.0	16	-	M12	25	47.0	100	95	142
74200.W0312	Threaded Bore	10.0	25.0	20	-	M16	32	59.5	125	119	297
74200.W0316	Threaded Bore	12.5	31.0	25	-	M20	40	75.7	160	152	566
74200.W0320	Threaded Bore	18.0	41.0	32	-	M24	50	97.0	200	190	1140

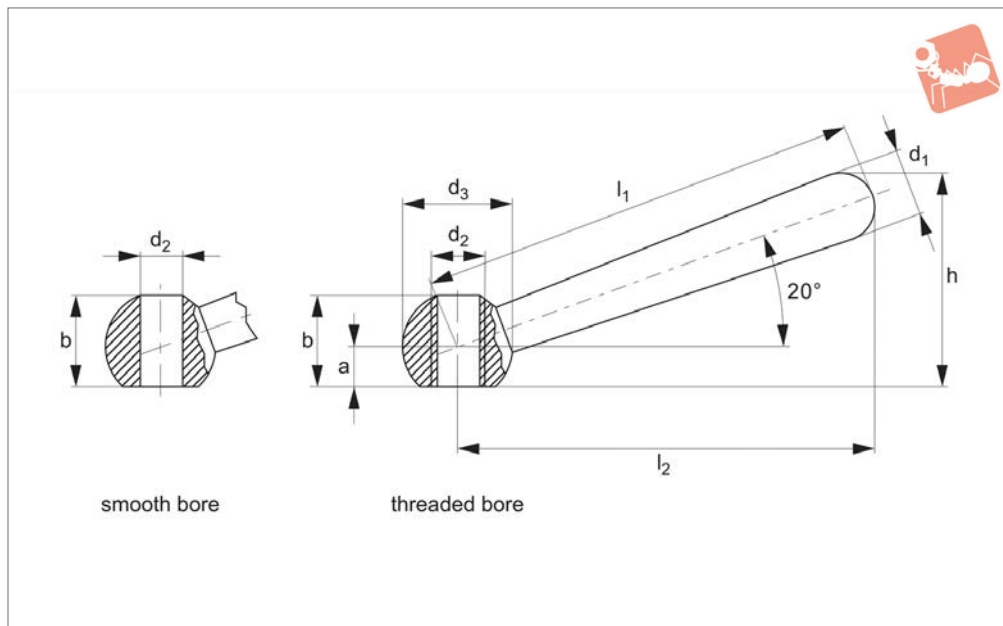

74201

CLAMPING LEVERS

Material

Stainless steel 1.4305 (AISI 303), dull blasted.

Order No.	Finish	a	b ≈	d_1	d_2 tol. H7	d_2	d_3	h ≈	l_1	l_2 ≈	Weight g
74201.W0206	Smooth Bore	5.0	12.0	10	8	-	16	30.5	63	60	37
74201.W0208	Smooth Bore	6.0	14.5	13	10	-	20	38.0	80	76	73
74201.W0210	Smooth Bore	7.5	18.5	16	12	-	25	47.0	100	95	140
74201.W0405	Threaded Bore	4.0	9.5	8	-	M_6	12	24.0	50	48	17
74201.W0406	Threaded Bore	5.0	12.5	10	-	M_8	16	30.5	63	60	38
74201.W0408	Threaded Bore	6.0	15.0	13	-	M10	20	38.0	80	76	74
74201.W0410	Threaded Bore	7.5	19.0	16	-	M12	25	47.0	100	95	142
74201.W0412	Threaded Bore	10.0	25.0	20	-	M16	32	59.5	125	119	297



74300

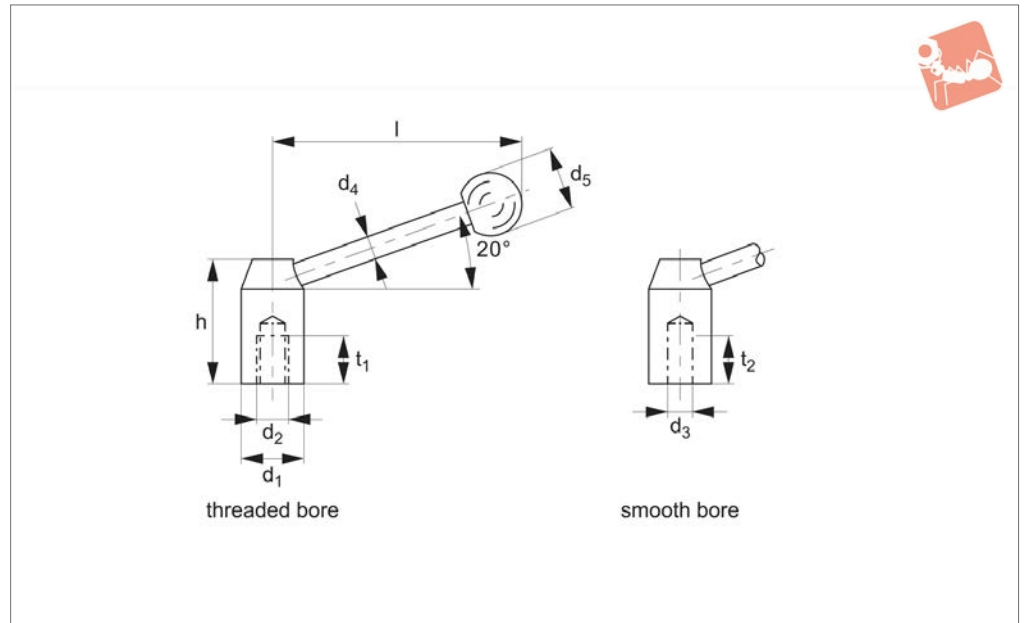

Material

Ball knob: plastic type 31 black.

Handle: free-cutting steel, finish-turned or ground, blackened.

Order No.	Finish	d_1	d_2	d_3 tol. H7	d_4	d_5	h	l ≈	t_1	t_2	Weight g
74300.W0022	Threaded Bore	20	M 8	-	8	20	33	65	15	-	97
74300.W0032	Threaded Bore	22	M10	-	8	20	37	82	15	-	113
74300.W0038	Threaded Bore	25	M12	-	10	25	42	96	18	-	165
74300.W0042	Threaded Bore	28	M12	-	12	30	47	110	18	-	262
74300.W0048	Threaded Bore	32	M16	-	12	32	52	124	23	-	354
74300.W0052	Threaded Bore	36	M16	-	14	35	58	138	24	-	519
74300.W0058	Threaded Bore	40	M20	-	16	40	64	152	27	-	715
74300.W0020	Smooth Bore	20	-	10	8	20	33	67	-	16	91
74300.W0030	Smooth Bore	22	-	10	8	20	37	82	-	18	117
74300.W0035	Smooth Bore	25	-	12	10	25	42	96	-	21	170
74300.W0040	Smooth Bore	28	-	12	12	30	47	110	-	22	268
74300.W0045	Smooth Bore	32	-	16	12	32	52	124	-	25	351
74300.W0050	Smooth Bore	36	-	16	14	35	58	138	-	26	524
74300.W0055	Smooth Bore	40	-	20	16	40	64	152	-	29	700

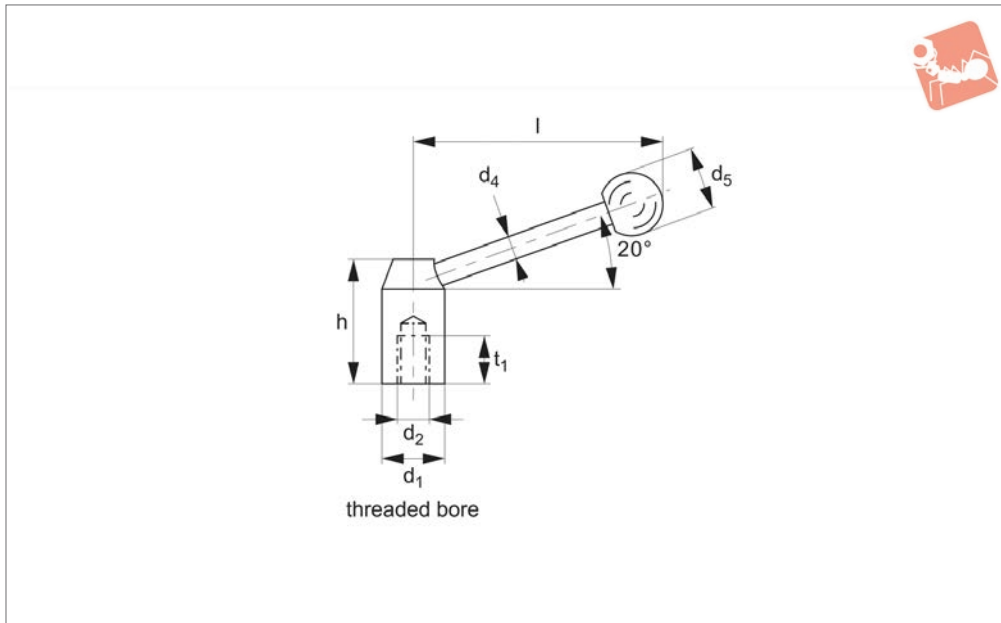

74301

CLAMPING LEVERS

Material

Handle: stainless steel 1.4305 (AISI 303).
Dull blasted.

Ball knob: plastic type 31 black.

Order No.	Finish	d ₁	d ₂	d ₄	d ₅	h	l	t ₁	Weight g
74301.W0230	Threaded Bore	22	M 8	8	20	37	70	15	121
74301.W0236	Threaded Bore	25	M10	10	25	42	96	15	186
74301.W0242	Threaded Bore	28	M12	12	30	47	110	18	262
74301.W0248	Threaded Bore	32	M16	12	32	52	124	23	354



CLAMPING LEVERS



74470

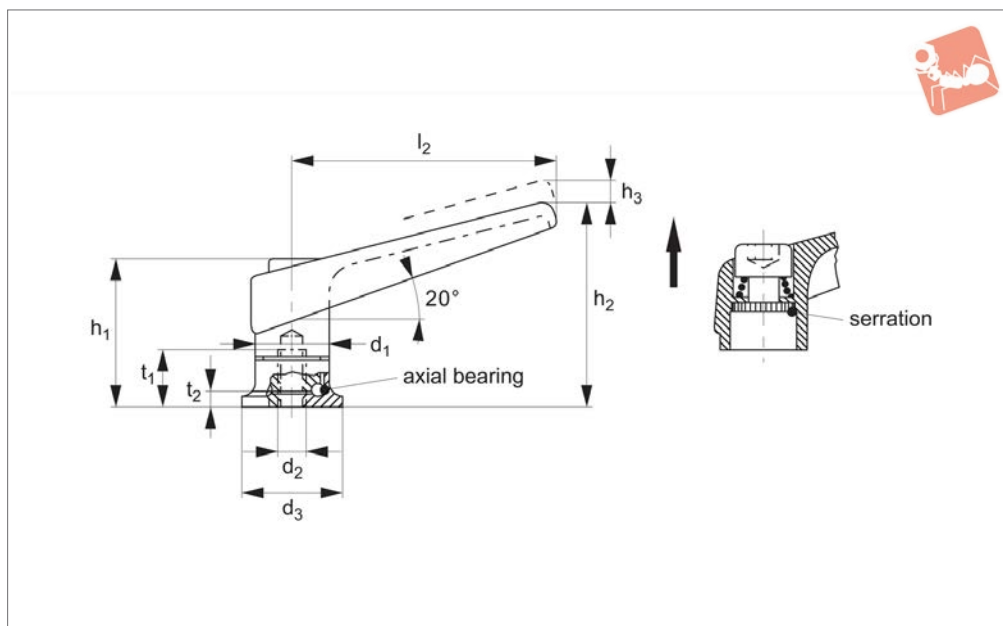

Material

Lever: die-cast zinc.

Orange RAL 2004,

Black RAL 9005.

Inner parts: heat-treated steel, nitrided, black.

Threaded part: steel, nitrided, blackened.

Technical Notes

By lifting the lever, the serrations are

disengaged. The lever can be positioned by the serrations and the threaded insert can be exchanged. On releasing the lever, the serrations are automatically re-engaged. The collar screw is torx head.

Tips

Benefits of axial bearing:

- clamping force is 100% greater than when using standard levers (see graph).

- smaller clamping levers can be used due to the improved clamping force.

- considerably less force loss due to setting.

- no releasing due to vibration.

- no damage to clamped parts, due to axial action.

Order No.	Finish	d ₁	d ₂	d ₃	h ₁	h ₂	h ₃	l ₂	t ₁ min.	t ₂	Weight g
74470.W0010	Orange	18	M_6	24.0	34.5	50	3.0	62	12.5	5.0	99
74470.W0110	Orange	22	M_8	25.0	39.5	56	3.5	74	14.0	4.2	140
74470.W0210	Orange	25	M10	30.0	46.5	66	4.0	89	18.0	5.4	207
74470.W0310	Orange	30	M12	35.0	56.5	82	5.0	108	26.5	6.6	359
74470.W0012	Black	18	M_6	24.0	34.5	50	3.0	62	12.5	5.0	99
74470.W0112	Black	22	M_8	25.0	39.5	56	3.5	74	14.0	4.2	140
74470.W0212	Black	25	M10	30.0	46.5	66	4.0	89	18.0	5.4	207
74470.W0312	Black	30	M12	35.0	56.5	82	5.0	108	26.5	6.6	359



Adjustable Clamping Levers with axial bearing - threaded bore

Clamping Levers

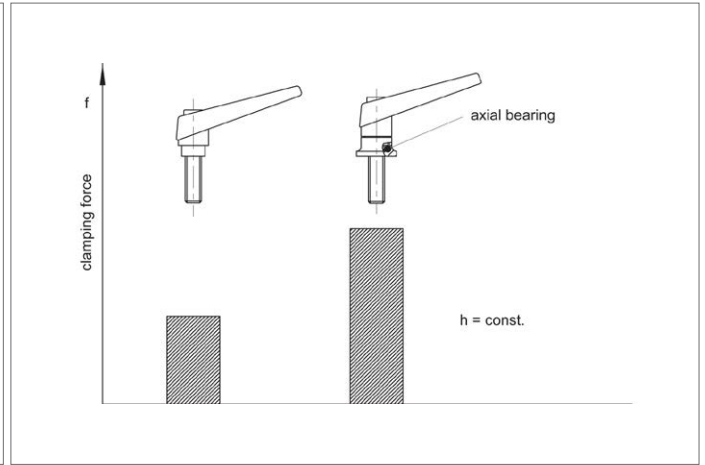
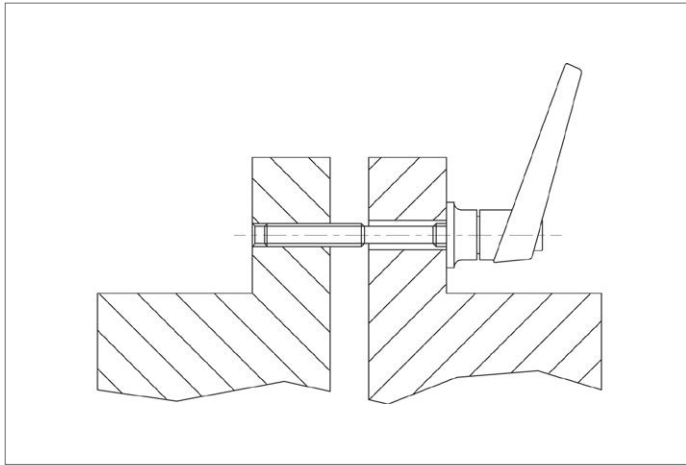

CLAMPING LEVERS



70550

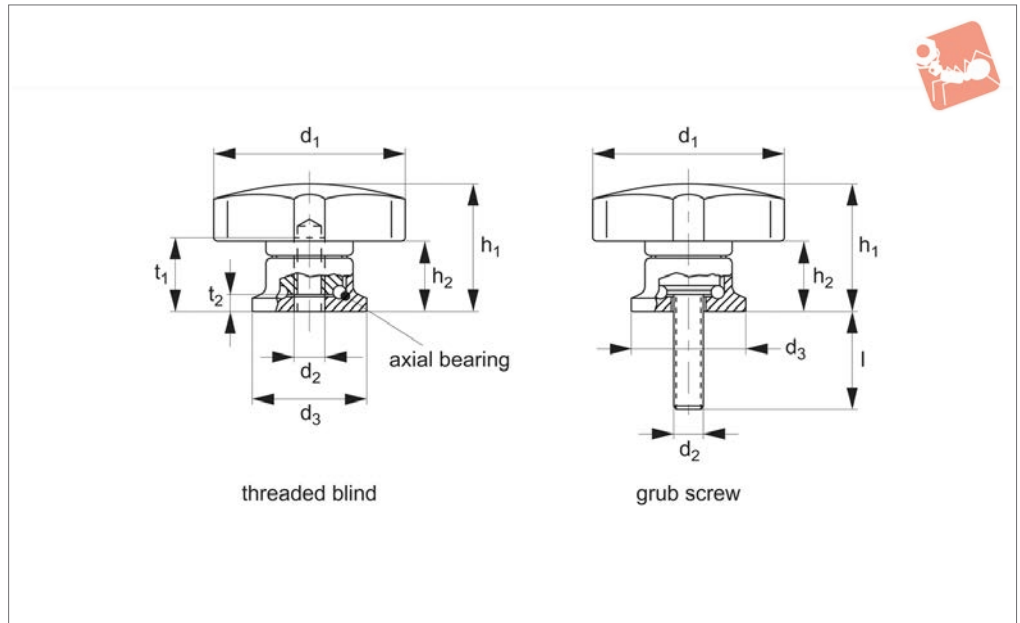

Material

Grip: thermoplast (PA).
Inner part: heat-treated steel, nitrited black.
Screw: quality 8.8, blackened.

Technical Notes

Advantages of axial bearing:
- Double clamping force with same lever size, by reducing the surface friction.
- Protection of work piece by fixed locating

face.

- Little setting due to higher pre-clamping force of bolt.
Temperature resistance +80°C max.

Order No.	Finish	d ₁	d ₂	d ₃	h ₁ ≈	h ₂ ≈	l +2	t ₁ min.	t ₂	Weight g
70550.W0040	Threaded, Blind	40	M 6	24	27	15.0	-	12.5	5.0	45
70550.W0050	Threaded, Blind	50	M 8	25	34	22.5	-	14.0	4.2	68
70550.W0063	Threaded, Blind	63	M10	30	41	26.5	-	18.0	5.4	111
70550.W0080	Threaded, Blind	80	M12	35	54	34.0	-	26.5	6.6	218
70550.W0042	Grub Screw	40	M 6	24	27	15.0	15	-	-	50
70550.W0044	Grub Screw	40	M 6	24	27	15.0	25	-	-	52
70550.W0053	Grub Screw	50	M 8	25	34	22.5	20	-	-	81
70550.W0056	Grub Screw	50	M 8	25	34	22.5	35	-	-	86
70550.W0066	Grub Screw	63	M10	30	41	26.5	30	-	-	137
70550.W0068	Grub Screw	63	M10	30	41	26.5	40	-	-	142
70550.W0083	Grub Screw	80	M12	35	54	34.0	30	-	-	258
70550.W0087	Grub Screw	80	M12	35	54	34.0	50	-	-	276

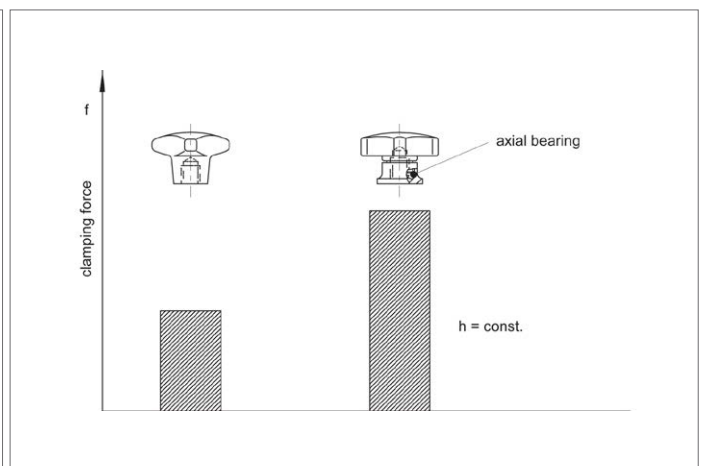
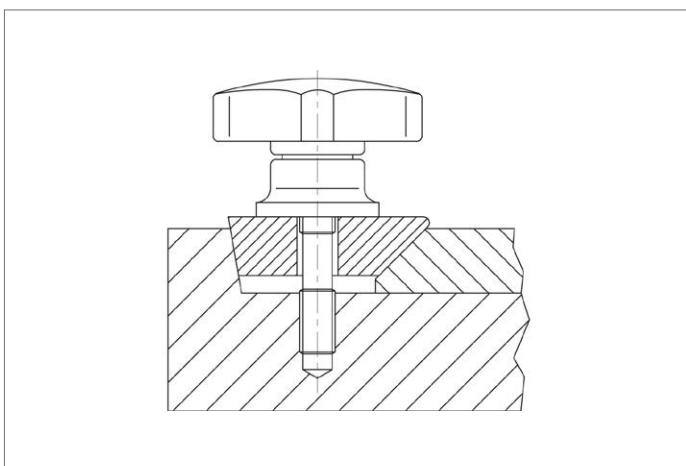



Adjustable Clamping Levers

with axial bearing, from stainless steel, with female

Clamping Levers

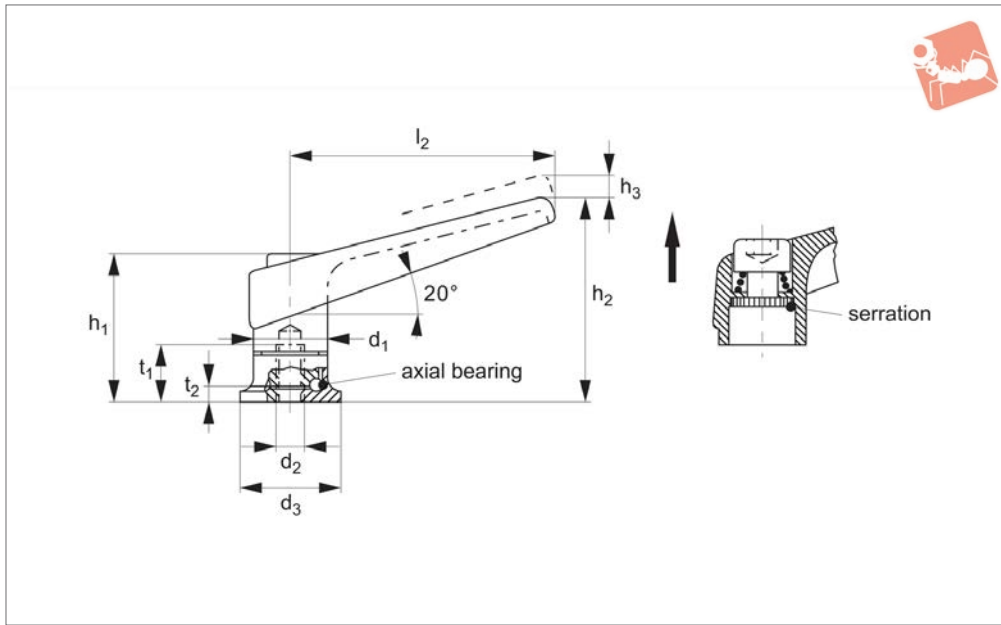

74472

CLAMPING LEVERS

Material

Lever: zinc die-cast, orange, similar to RAL 2004. Zinc die-cast, black, similar to RAL 9005.

Threaded part: stainless steel.

Inner part: stainless steel.

Threaded part: stainless steel, hardened.

Technical Notes

By lifting the lever, the serrations are

disengaged. The lever can be positioned by the serrations and the threaded insert can be exchanged. On releasing the lever, the serrations are automatically re-engaged.

Tips

Benefits of axial bearing:

- clamping force is 100% greater than when using standard levers (see graph).
- smaller clamping levers can be used due

to the improved clamping force.

- considerably less force loss due to setting.
- no releasing due to vibration.
- no damage to clamped parts, due to axial action.

Order No.	Colour	d ₁	d ₂	d ₃	h ₁	h ₂	h ₃	l ₂	t ₁ min.	t ₂	Weight g
74472.W1010	Orange	18	M 6	24	34.5	50	3.0	62	12.5	5.0	99
74472.W1012	Black	18	M 6	24	34.5	50	3.0	62	12.5	5.0	99
74472.W1110	Orange	22	M 8	25	39.5	56	3.5	74	14.0	4.2	140
74472.W1112	Black	22	M 8	25	39.5	56	3.5	74	14.0	4.2	140
74472.W1210	Orange	25	M10	30	46.5	66	4.0	89	18.0	5.4	207
74472.W1212	Black	25	M10	30	46.5	66	4.0	89	18.0	5.4	207
74472.W1310	Orange	30	M12	35	56.5	82	5.0	108	26.5	6.6	359
74472.W1312	Black	30	M12	35	56.5	82	5.0	108	26.5	6.6	359



74480

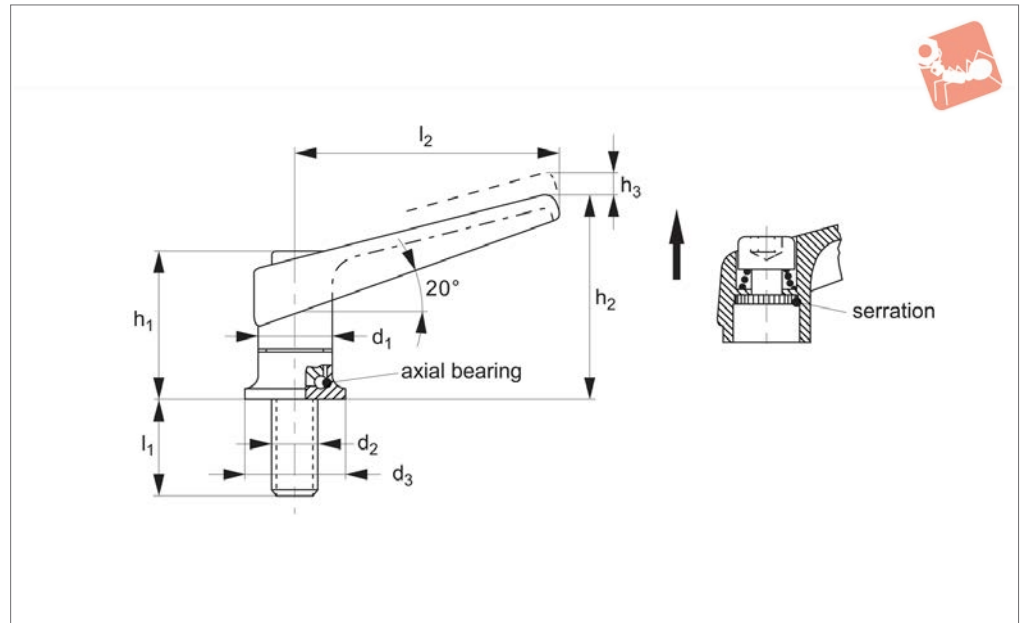

Material

Lever: die-cast zinc.
 Orange RAL 2004,
 Black RAL 9005.
 Inner parts: heat-treated steel, nitrided,
 blackened.
 Screw: steel, nitrided, blackened.

Technical Notes

Lifting the lever disengages the serrations

and the lever can be positioned. On releasing the lever the serrations are automatically re-engaged.

Tips

Benefits of axial bearing:
 - clamping force is 100% greater than when using standard levers (see graph).
 - smaller clamping levers can be used due to the improved clamping force.

- considerably less force loss due to setting.
 - no releasing due to vibration.
 - no damage to clamped parts, due to axial action.

Order No.	Finish	d ₁	d ₂	d ₃	h ₁	h ₂	h ₃	l ₁	l ₂	Weight g
74480.W0030	Orange	18	M_6	24	34.5	50	3.0	20	62	97
74480.W0050	Orange	18	M_6	24	34.5	50	3.0	27	62	98
74480.W0130	Orange	22	M_8	25	39.5	56	3.5	21	74	151
74480.W0150	Orange	22	M_8	25	39.5	56	3.5	36	74	157
74480.W0230	Orange	25	M10	30	46.5	66	4.0	29	89	232
74480.W0250	Orange	25	M10	30	46.5	66	4.0	47	89	242
74480.W0330	Orange	30	M12	35	56.5	82	5.0	34	108	412
74480.W0346	Orange	30	M12	35	56.5	82	5.0	50	108	420
74480.W0350	Orange	30	M12	35	56.5	82	5.0	57	108	426
74480.W0364	Orange	30	M12	35	56.5	82	5.0	65	108	431
74480.W0384	Orange	30	M12	35	56.5	82	5.0	85	108	449
74480.W0032	Black	18	M_6	24	34.5	50	3.0	20	62	97
74480.W0052	Black	18	M_6	24	34.5	50	3.0	27	62	98
74480.W0132	Black	22	M_8	25	39.5	56	3.5	21	74	151
74480.W0152	Black	22	M_8	25	39.5	56	3.5	36	74	157
74480.W0232	Black	25	M10	30	46.5	66	4.0	29	89	232
74480.W0252	Black	25	M10	30	46.5	66	4.0	47	89	242
74480.W0332	Black	30	M12	35	56.5	82	5.0	34	108	412
74480.W0348	Black	30	M12	35	56.5	82	5.0	50	108	420
74480.W0352	Black	30	M12	35	56.5	82	5.0	57	108	426
74480.W0366	Black	30	M12	35	56.5	82	5.0	65	108	431
74480.W0386	Black	30	M12	35	56.5	82	5.0	85	108	449



Adjustable Clamping Levers with axial bearing - with grub screw

Clamping Levers

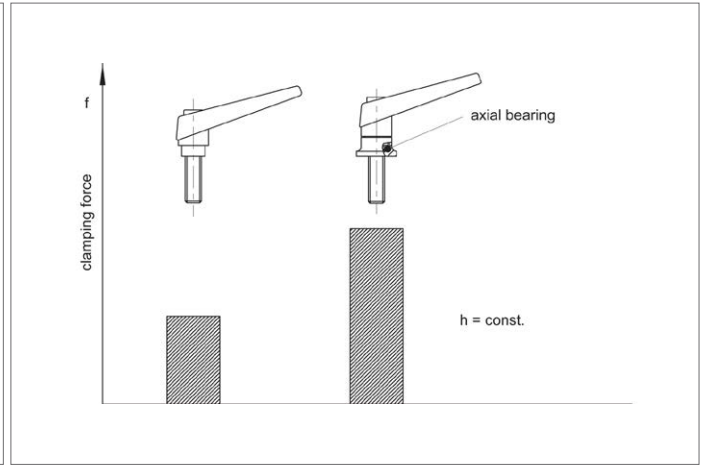
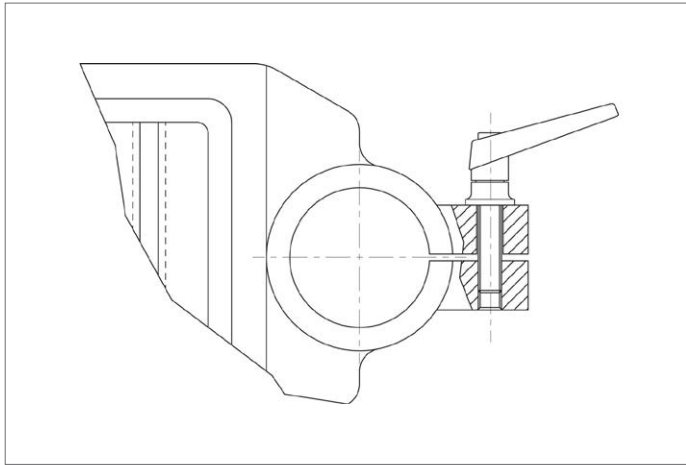

CLAMPING LEVERS



74482

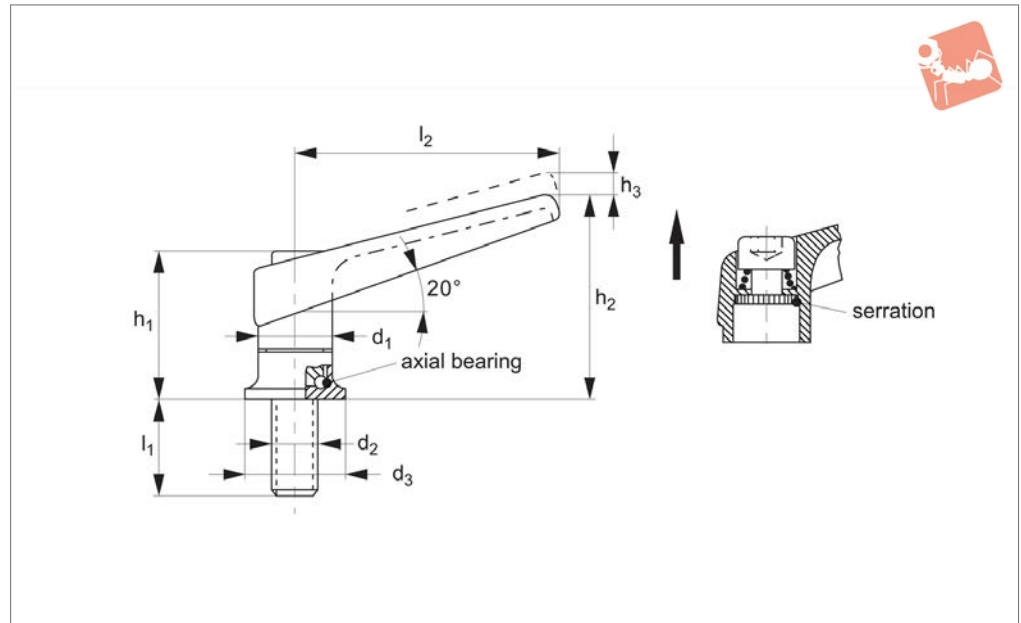

Material

Lever: zinc die-cast, orange, similar to RAL 2004. Zinc die-cast, black, similar to RAL 9005.

Screw: stainless steel.

Inner parts: stainless steel.

Threaded part: stainless steel, hardened.

Technical Notes

Lifting the lever disengages the serrations

and the lever can be positioned. On releasing the lever the serrations are automatically re-engaged.

Tips

Benefits of axial bearing:

- clamping force is 100% greater than when using standard levers (see graph).
- smaller clamping levers can be used due to the improved clamping force.

- considerably less force loss due to setting.

- no releasing due to vibration.

- no damage to clamped parts, due to axial action.

Order No.	Colour	d ₁	d ₂	d ₃	h ₁	h ₂	h ₃	l ₁	l ₂	Weight g
74482.W1030	Orange	18	M 6	24	34.5	50	3.0	20	62	97
74482.W1032	Black	18	M 6	24	34.5	50	3.0	20	62	97
74482.W1050	Orange	18	M 6	24	34.5	50	3.0	27	62	98
74482.W1052	Black	18	M 6	24	34.5	50	3.0	27	62	98
74482.W1130	Orange	22	M 8	25	39.5	56	3.5	21	74	151
74482.W1132	Black	22	M 8	25	39.5	56	3.5	21	74	151
74482.W1150	Orange	22	M 8	25	39.5	56	3.5	36	74	157
74482.W1152	Black	22	M 8	25	39.5	56	3.5	36	74	157
74482.W1230	Orange	25	M10	30	46.5	66	4.0	29	89	232
74482.W1232	Black	25	M10	30	46.5	66	4.0	29	89	232
74482.W1250	Orange	25	M10	30	46.5	66	4.0	47	89	242
74482.W1252	Black	25	M10	30	46.5	66	4.0	47	89	242
74482.W1330	Orange	30	M12	35	56.5	82	5.0	34	108	412
74482.W1332	Black	30	M12	35	56.5	82	5.0	34	108	412
74482.W1346	Orange	30	M12	35	56.5	82	5.0	50	108	420
74482.W1348	Black	30	M12	35	56.5	82	5.0	50	108	420
74482.W1350	Orange	30	M12	35	56.5	82	5.0	57	108	426
74482.W1352	Black	30	M12	35	56.5	82	5.0	57	108	426
74482.W1364	Orange	30	M12	35	56.5	82	5.0	65	108	431
74482.W1366	Black	30	M12	35	56.5	82	5.0	65	108	431
74482.W1384	Orange	30	M12	35	56.5	82	5.0	85	108	449
74482.W1386	Black	30	M12	35	56.5	82	5.0	85	108	449



Adjustable Clamping Levers

with axial bearing, from stainless steel, with screw

Clamping Levers

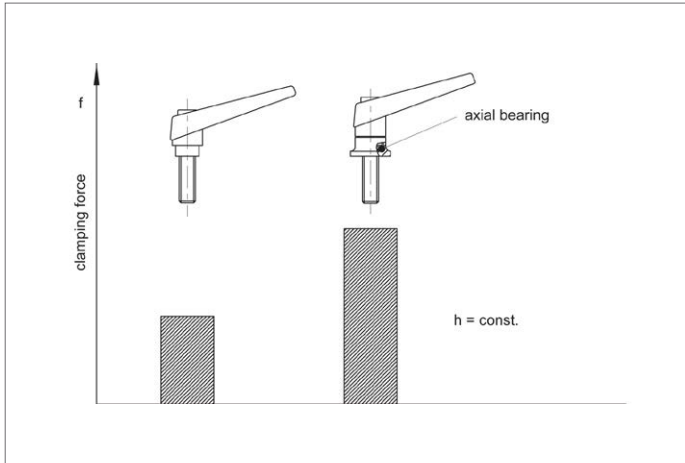



74860

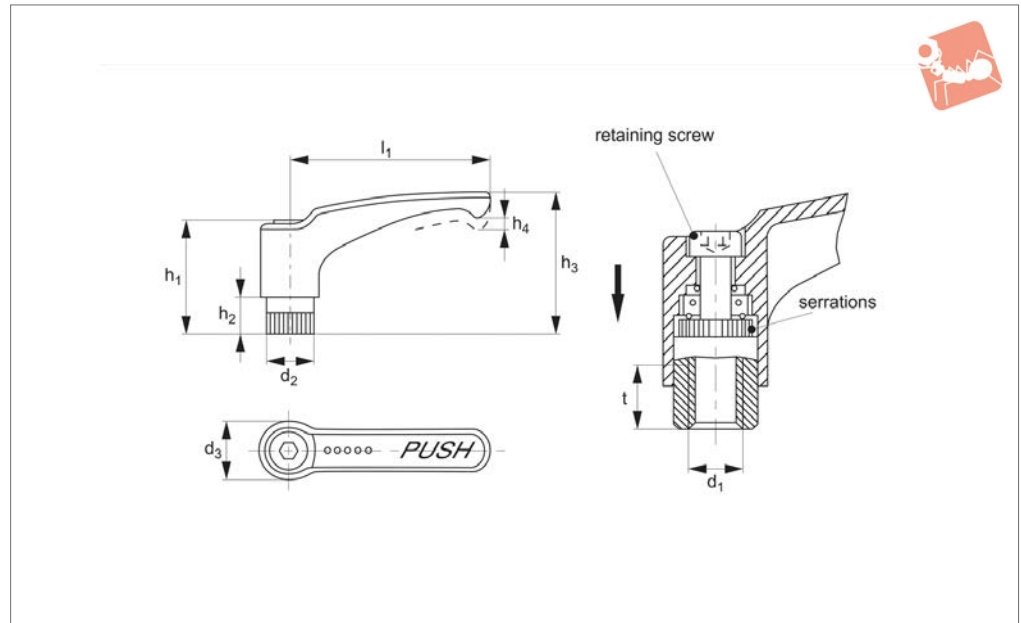

Material

Plastic technopolymer (polyamide PA) glass fibre reinforced, black.
Inner parts: steel, blackened embedded in black plastic.

Tips

Unique Safety Handle.

When not in use, the lever is not engaged with threaded insert, i.e. the adjustable lever turns freely.

As soon as the lever hub is pushed down, both serrations will engage, allowing the fixture to be released or clamped.

After „releasing“, the lever disengages

through spring tension.

Important Notes

Used where accidental loosening or readjustment can result in accidents.
Temperature resistant to +130°C.

Order No.	l_1	d_1	d_2	d_3	h_1	h_2	h_3	h_4 stroke	t min.	Weight g
74860.W0041	44	M 4	12	15.5	29	9	36	3.5	10	14
74860.W0042	44	M 5	12	15.5	29	9	36	3.5	10	13
74860.W0043	44	M 6	12	15.5	29	9	36	3.5	10	12
74860.W0061	63	M 6	15	19.0	37	12	48	4.0	13	25
74860.W0062	63	M 8	15	19.0	37	12	48	4.0	13	24



Free Running Safety Star Grip

free-running when not engaged

Clamping Levers

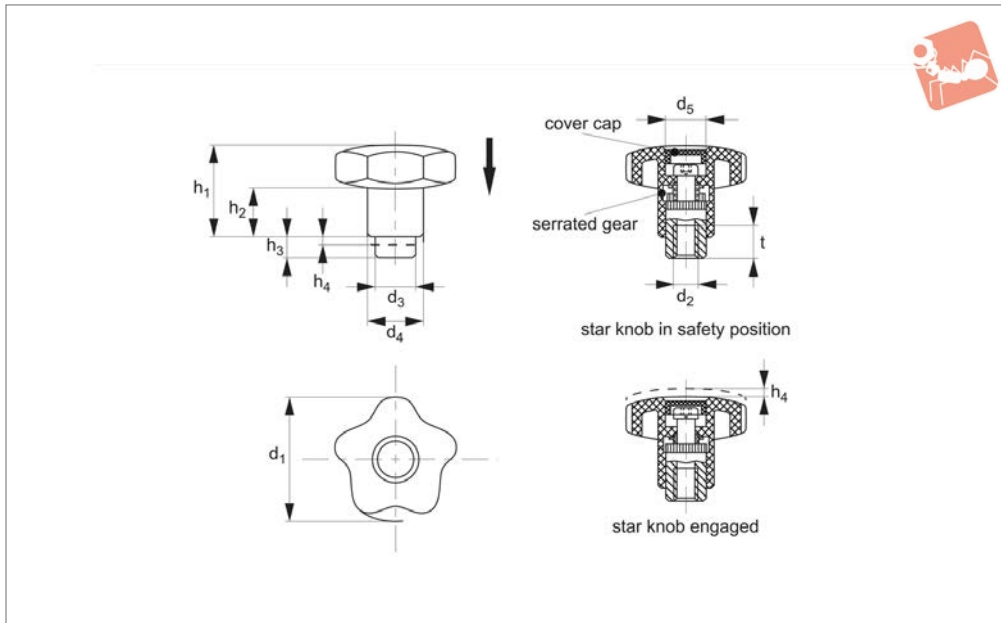

70300

CLAMPING LEVERS

Material

Plastic technopolymer (Polyamide PA)
glass fibre reinforced, black.
Thread bush, steel.
Inner parts: zinc die cast.

dental loosening or adjusting of the knob may lead to accidents.
Temperature resistant to +130°C.

pushing of the star knob, the two serrations get engaged so that the knob can be loosened/ tightened. After releasing, the two serrations are disengaged by a spring.

Technical Notes

Suitable for applications where an acci-

Tips

Unique safety handle:
When not in use, star knob is not engaged with the threaded insert, i.e. the knob is free-running. Only after axial

Order No.	d ₁	d ₂	d ₃	d ₄	d ₅	h ₁	h ₂	h ₃	h ₄ stroke	t min.
70300.W0061	40	M 6	13.5	18	13.5	30	14	7	2.5	11
70300.W0081	40	M 8	13.5	18	13.5	30	14	7	2.5	11
70300.W0082	50	M 8	16.0	22	16.5	34	15	8	3.5	14
70300.W0101	50	M10	16.0	22	16.5	34	15	8	3.5	14



70310

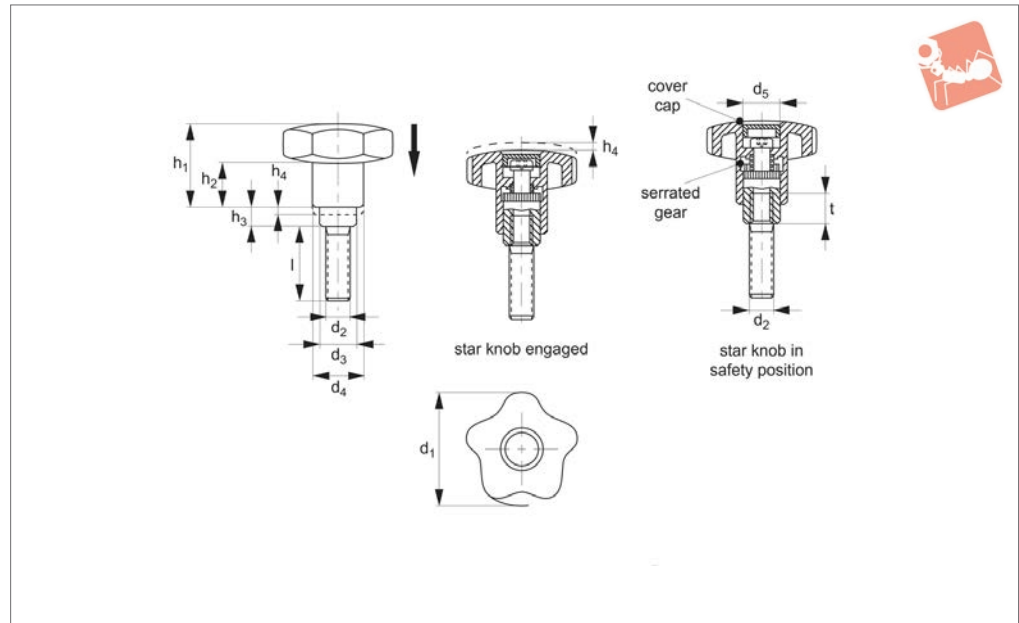

Material

Plastic technopolymer (Polyamide PA) glass fibre reinforced, black.
Thread bush, steel.
Inner parts: zinc die cast.

dental loosening or adjusting of the knob may lead to accidents.
Temperature resistant to +130°C.

pushing of the star knob, the two serrations get engaged so that the knob can be loosened/ tightened. After releasing, the two serrations are disengaged by a spring.

Technical Notes

Suitable for applications where an acci-

Tips

Unique safety handle.
When not in use, star knob is not engaged with the threaded insert, i.e. the knob is free-running. Only after axial

Order No.	d ₁	d ₂	l	d ₃	d ₄	d ₅	h ₁	h ₂	h ₃	h ₄ stroke
70310.W0061	40	M 6	20	13.5	18	13.5	30	14	7	2.5
70310.W0062	40	M 6	25	13.5	18	13.5	30	14	7	2.5
70310.W0063	40	M 6	32	13.5	18	13.5	30	14	7	2.5
70310.W0064	40	M 6	40	13.5	18	13.5	30	14	7	2.5
70310.W0081	40	M 8	20	13.5	18	13.5	30	14	7	2.5
70310.W0082	40	M 8	25	13.5	18	13.5	30	14	7	2.5
70310.W0083	40	M 8	32	13.5	18	13.5	30	14	7	2.5
70310.W0084	40	M 8	40	13.5	18	13.5	30	14	7	2.5
70310.W0085	50	M 8	25	16.0	22	16.5	34	15	8	3.5
70310.W0086	50	M 8	32	16.0	22	16.5	34	15	8	3.5
70310.W0087	50	M 8	40	16.0	22	16.5	34	15	8	3.5
70310.W0088	50	M 8	50	16.0	22	16.5	34	15	8	3.5
70310.W0101	50	M10	25	16.0	22	16.5	34	15	8	3.5
70310.W0102	50	M10	32	16.0	22	16.5	34	15	8	3.5
70310.W0103	50	M10	40	16.0	22	16.5	34	15	8	3.5
70310.W0104	50	M10	50	16.0	22	16.5	34	15	8	3.5



Free Running Safety Clamping Lever, free-running when not engaged

Clamping Levers

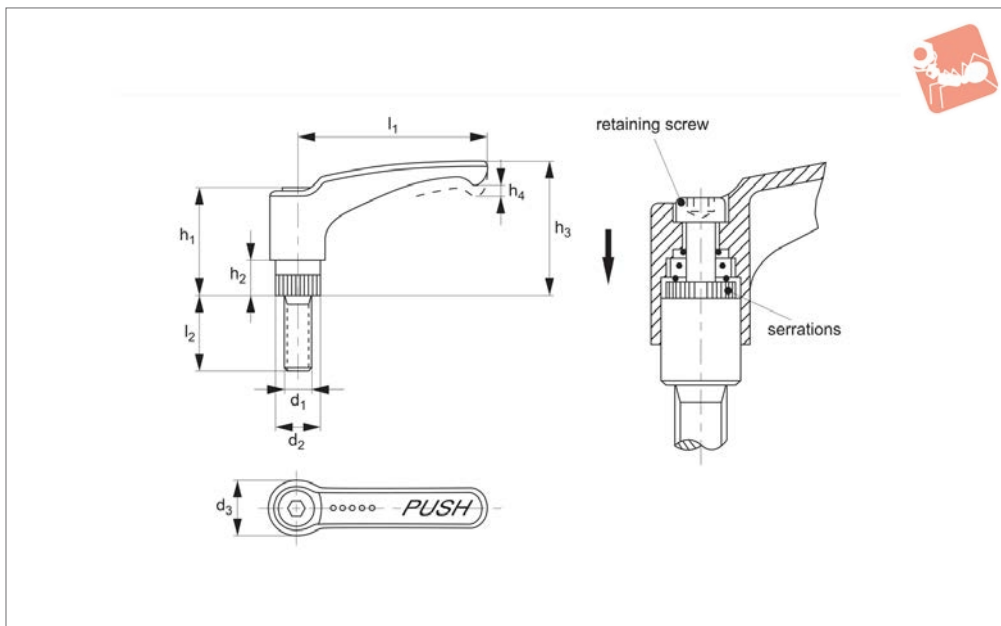

74880

CLAMPING LEVERS

Material

Plastic technopolymer (polyamide PA) glass fibre reinforced, black.
Inner parts: steel, blackened embedded in black plastic.

Tips

Unique Safety Handle.

When not in use, the lever is not engaged with threaded insert, i.e. the adjustable lever turns freely.

As soon as the lever hub is pushed down, both serrations will engage, allowing the fixture to be released or clamped.

After „releasing“, the lever disengages

through spring tension.

Important Notes

Used where accidental loosening or readjustment can result in accidents.
Temperature resistant to +130°C.

Order No.	l_1	d_1	d_2	d_3	h_1	h_2	h_3	h_4 stroke	l_2	Weight g
74880.W0061	44	M 6	12	15.5	29	9	36	3.5	16	18
74880.W0062	44	M 6	12	15.5	29	9	36	3.5	25	21
74880.W0081	63	M 8	15	19.0	37	12	48	4.0	20	38
74880.W0082	63	M 8	15	19.0	37	12	48	4.0	30	43



77300

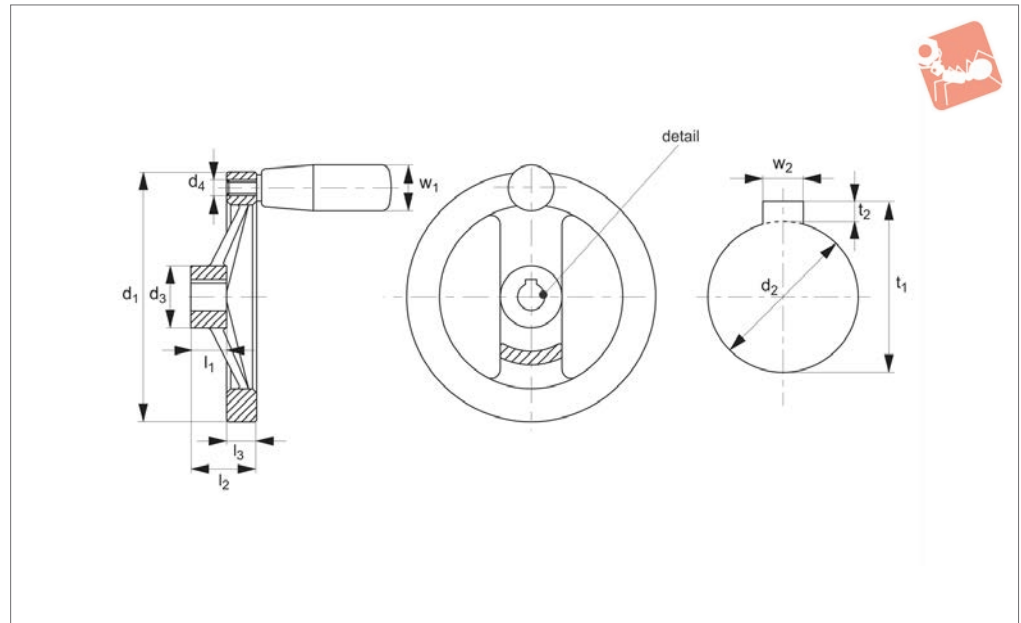

Material

Aluminium mould casting. Plastic handle PF 31, DIN 7708.

Hub machined; rim turned and mirror-finished on all sides, non-machined surfaces cleanly blasted.

For corresponding handle details see no. 75120 rotating handle.

Technical Notes

The non-machined, raw surfaces are blasted; together with the mirror-polished

rim these handwheels are therefore showing a finish which in most cases does not require additional lacquering.

For keyways information (dim. t_1 and b_3) to DIN 6885.

Order No.	Type	Bore dia.	d_1	d_2 tol. H7 Small	d_2 tol. H7 Large	d_3	d_4	l_1	l_2 ≈	l_3	w_1	Weight g
77300.W0012	W/o Keyway, W/o Handle	d_2 Small	125	12	14	31	-	18	33	15.0	-	301
77300.W0013	W/o Keyway, W/o Handle	d_2 Large	125	12	14	31	-	18	33	15.0	-	301
77300.W0014	W/o Keyway, W/o Handle	d_2 Small	140	14	16	36	-	19	36	16.5	-	400
77300.W0015	W/o Keyway, W/o Handle	d_2 Large	140	14	16	36	-	19	36	16.5	-	400
77300.W0016	W/o Keyway, W/o Handle	d_2 Small	160	14	16	36	-	20	39	18.0	-	520
77300.W0017	W/o Keyway, W/o Handle	d_2 Large	160	14	16	36	-	20	39	18.0	-	520
77300.W0020	W/o Keyway, W/o Handle	d_2 Small	200	18	20	42	-	24	45	20.5	-	886
77300.W0021	W/o Keyway, W/o Handle	d_2 Large	200	18	20	42	-	24	45	20.5	-	886
77300.W0025	W/o Keyway, W/o Handle	d_2 Small	250	22	26	48	-	28	51	23.0	-	1454
77300.W0026	W/o Keyway, W/o Handle	d_2 Large	250	22	26	48	-	28	51	23.0	-	1454
77300.W0112	With Keyway, W/o Handle	d_2 Small	125	12	14	31	-	18	33	15.0	-	303
77300.W0113	With Keyway, W/o Handle	d_2 Large	125	12	14	31	-	18	33	15.0	-	303
77300.W0114	With Keyway, W/o Handle	d_2 Small	140	14	16	36	-	19	36	16.5	-	406
77300.W0115	With Keyway, W/o Handle	d_2 Large	140	14	16	36	-	19	36	16.5	-	406
77300.W0116	With Keyway, W/o Handle	d_2 Small	160	14	16	36	-	20	39	18.0	-	542
77300.W0117	With Keyway, W/o Handle	d_2 Large	160	14	16	36	-	20	39	18.0	-	542
77300.W0120	With Keyway, W/o Handle	d_2 Small	200	18	20	42	-	24	45	20.5	-	914
77300.W0121	With Keyway, W/o Handle	d_2 Large	200	18	20	42	-	24	45	20.5	-	914
77300.W0125	With Keyway, W/o Handle	d_2 Small	250	22	26	48	-	28	51	23.0	-	1446
77300.W0126	With Keyway, W/o Handle	d_2 Large	250	22	26	48	-	28	51	23.0	-	1446
77300.W0512	W/o Keyway, With Handle	d_2 Small	125	12	14	31	M 8	18	33	15.0	23	390
77300.W0513	W/o Keyway, With Handle	d_2 Large	125	12	14	31	M 8	18	33	15.0	23	390
77300.W0514	W/o Keyway, With Handle	d_2 Small	140	14	16	36	M 8	19	36	16.5	23	490
77300.W0515	W/o Keyway, With Handle	d_2 Large	140	14	16	36	M 8	19	36	16.5	23	490
77300.W0516	W/o Keyway, With Handle	d_2 Small	160	14	16	36	M10	20	39	18.0	26	645
77300.W0517	W/o Keyway, With Handle	d_2 Large	160	14	16	36	M10	20	39	18.0	26	645
77300.W0520	W/o Keyway, With Handle	d_2 Small	200	18	20	42	M10	24	45	20.5	26	1000
77300.W0521	W/o Keyway, With Handle	d_2 Large	200	18	20	42	M10	24	45	20.5	26	1000
77300.W0525	W/o Keyway, With Handle	d_2 Small	250	22	26	48	M10	28	51	23.0	28	1585
77300.W0526	W/o Keyway, With Handle	d_2 Large	250	22	26	48	M10	28	51	23.0	28	1585
77300.W0612	With Keyway, With Handle	d_2 Small	125	12	14	31	M 8	18	33	15.0	23	390
77300.W0613	With Keyway, With Handle	d_2 Large	125	12	14	31	M 8	18	33	15.0	23	390



Handwheels - 2 Spoke



Handwheels

Order No.	Type	Bore dia.	d ₁	d ₂ tol. H7 Small	d ₂ tol. H7 Large	d ₃	d ₄	l ₁	l ₂ z	l ₃	w ₁	Weight g
77300.W0614	With Keyway, With Handle	d ₂ Small	140	14	16	36	M 8	19	36	16.5	23	490
77300.W0615	With Keyway, With Handle	d ₂ Large	140	14	16	36	M 8	19	36	16.5	23	490
77300.W0616	With Keyway, With Handle	d ₂ Small	160	14	16	36	M10	20	39	18.0	26	645
77300.W0617	With Keyway, With Handle	d ₂ Large	160	14	16	36	M10	20	39	18.0	26	645
77300.W0620	With Keyway, With Handle	d ₂ Small	200	18	20	42	M10	24	45	20.5	26	1000
77300.W0621	With Keyway, With Handle	d ₂ Large	200	18	20	42	M10	24	45	20.5	26	1000
77300.W0625	With Keyway, With Handle	d ₂ Small	250	22	26	48	M10	28	51	23.0	28	1585
77300.W0626	With Keyway, With Handle	d ₂ Large	250	22	26	48	M10	28	51	23.0	28	1585

HANDWHEELS

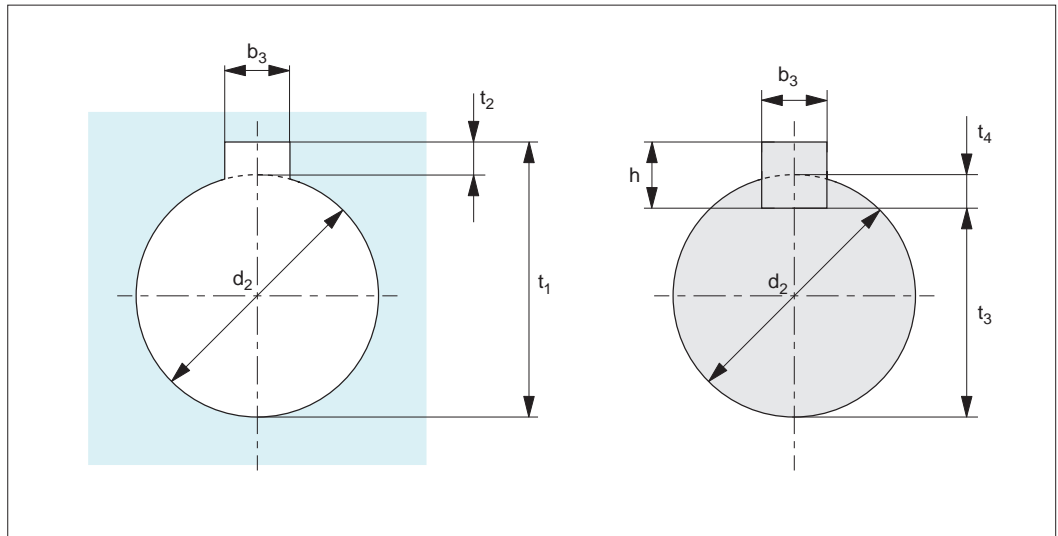

d_2	$b_{P9/JS9}$ hole	$b_{P9/N9}$ shaft	h	$t_1 = d_2 + t_2$	t_2	$t_3 = d_2 - t_4$	t_4
7	2	2	2	8	1+0,1	5,8	1,2+0,1
8	2	2	2	9	1	6,8	1,2
9	3	3	3	10,4	1,4	7,2	1,8
10	3	3	3	11,4	1,4	8,2	1,8
11	4	4	4	12,8	1,8	8,5	2,5
12	4	4	4	13,8	1,8	9,5	2,5
13	5	5	5	15,3	2,3	10	3
14	5	5	5	16,3	2,3	11	3
15	5	5	5	17,3	2,3	12	3
16	5	5	5	18,3	2,3	13	3
17	5	5	5	19,3	2,3	14	3
18	6	6	6	20,8	2,8	14,5	3,5
20	6	6	6	22,8	2,8	16,5	3,5
22	6	6	6	24,8	2,8	18,5	3,5
24	8	8	7	27,3	3,3+0,2	20	4+0,2
25	8	8	7	28,3	3,3	21	4
26	8	8	7	29,3	3,3	22	4
28	8	8	7	31,3	3,3	24	4
30	8	8	7	33,3	3,3	26	4
32	10	10	8	35,3	3,3	27	5
34	10	10	8	37,3	3,3	29	5
35	10	10	8	38,3	3,3	30	5
36	10	10	8	39,3	3,3	31	5
38	10	10	8	41,3	3,3	33	5
40	12	12	8	43,3	3,3	35	5
42	12	12	8	45,3	3,3	37	5
44	12	12	8	47,3	3,3	39	5

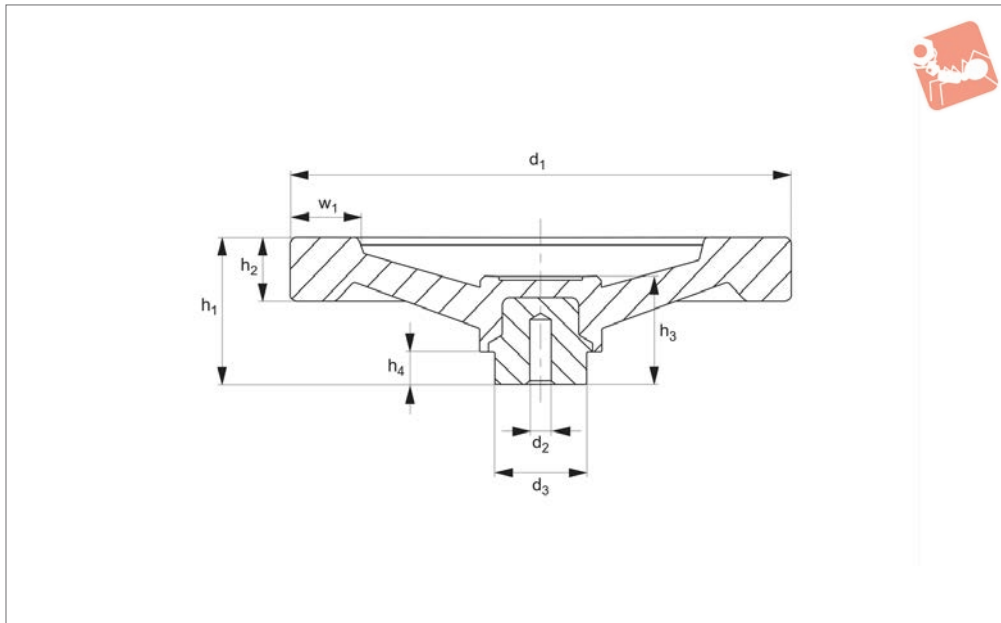

77340

HANDWHEELS

Material

Duroplast, black, matt. Zinc plated steel hub.

Technical Notes

The pilot hole allows various sizes of holes, keyways etc. to be machined into the hub

upon request.

Order No.	d ₁	d ₂	d ₃	h ₁	h ₂	h ₃	h ₄	w ₁	Weight g
77340.W0100	100	4	24	36	14	30	11	15	169
77340.W0125	125	4	24	41	16	34	11	18	253
77340.W0150	125	6	32	46	20	38	13	21	433
77340.W0200	200	6	40	62	25	45	16	26	933
77340.W0250	250	8	48	70	28	50	17	30	1484



77360

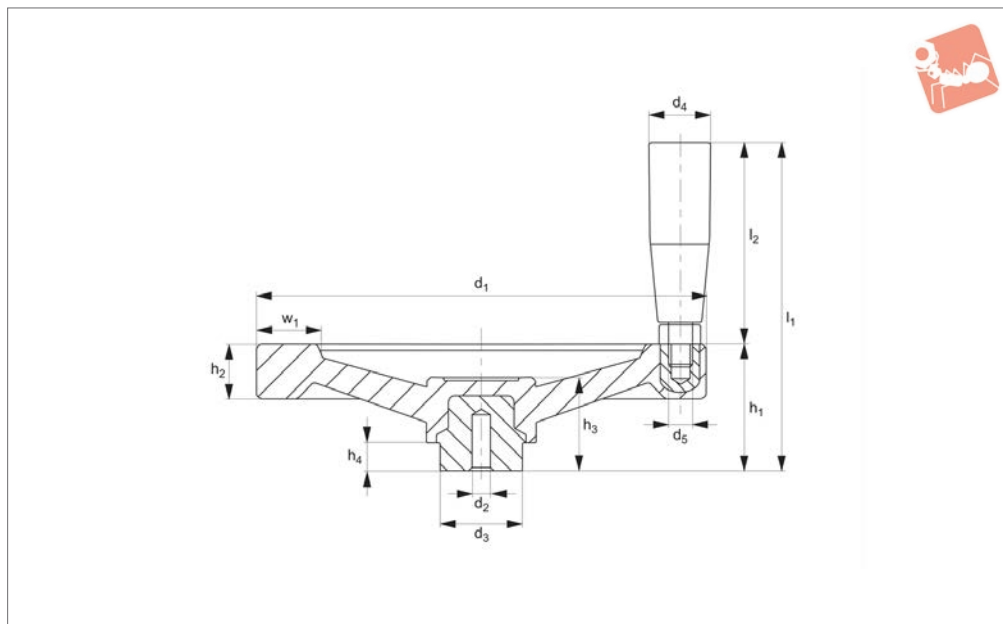

Material

Black duroplast. Zinc plated steel hub.

keyways etc. to be machined into the hub upon request.

Technical Notes

The pilot hole allows various sizes of holes,

Order No.	Type	d ₁	d ₂	d ₃	d ₄	d ₅	h ₁	h ₂	h ₃	h ₄	l ₁	l ₂	w ₁	Weight g
77360.W0100	Standard	100	4	24	17	M 8	36	14	30	11	81	40	15	198
77360.W0125	Standard	125	4	24	23	M 8	41	16	34	11	102	55	18	312
77360.W0150	Standard	150	6	32	25	M10	46	20	38	13	117	65	21	525
77360.W0200	Standard	200	6	40	28	M10	62	25	45	16	154	85	26	1070
77360.W0250	Standard	250	8	48	28	M10	70	28	50	17	162	85	30	1628
77360.W0600	Reinforced	100	4	24	17	M 8	36	14	30	11	81	40	15	195
77360.W0625	Reinforced	125	4	24	23	M 8	41	16	34	11	102	55	18	317
77360.W0650	Reinforced	150	6	32	25	M10	46	20	38	13	117	65	21	519
77360.W0700	Reinforced	200	6	40	28	M10	62	25	45	16	154	85	26	1080
77360.W0750	Reinforced	250	8	48	28	M10	70	28	50	17	162	85	30	1662



Two Spoked Handwheels with fold-away rotating grip

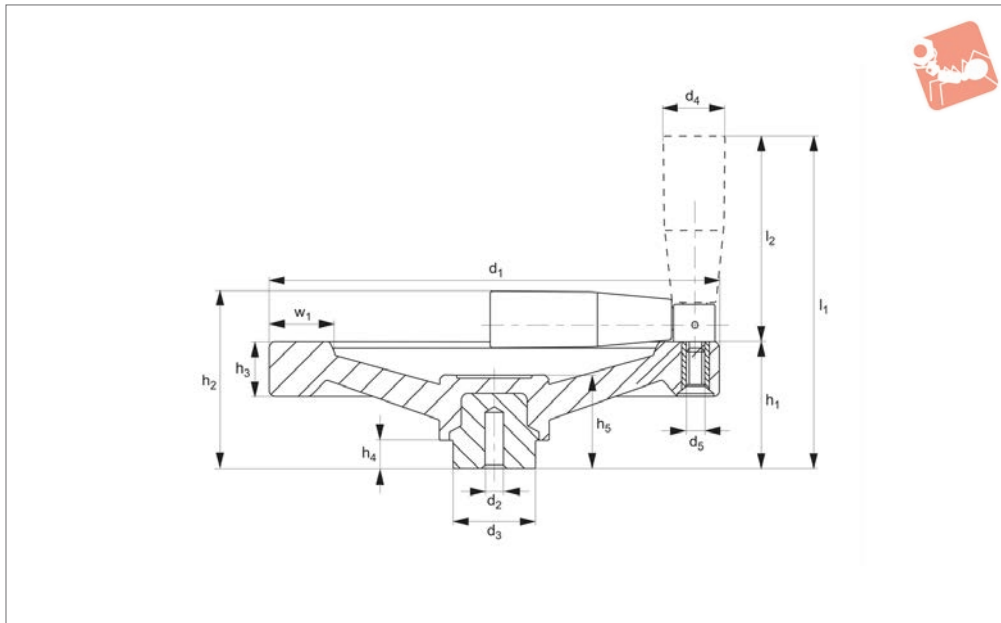

77380

HANDWHEELS

Material

Duroplast, black. Zinc plated steel hub.
Fold-away revolving handle.

Technical Notes

The pilot hole allows various sizes of holes, keyways etc. to be machined into the hub

upon request.

Order No.	d ₁	d ₂	d ₃	d ₄	d ₅	h ₁	h ₂	h ₃	h ₄	h ₅	l ₁	l ₂	w ₁	Weight g
77380.W0125	125	4	24	23	M 5	41	61	16	11	34	112	55	18	318
77380.W0150	150	6	32	25	M 6	46	67	20	13	38	128	65	21	500
77380.W0200	200	6	40	28	M 6	62	86	25	16	45	167	85	26	995
77380.W0250	250	8	48	28	M 6	70	94	28	17	50	175	85	30	1340



HANDWHEELS



77010

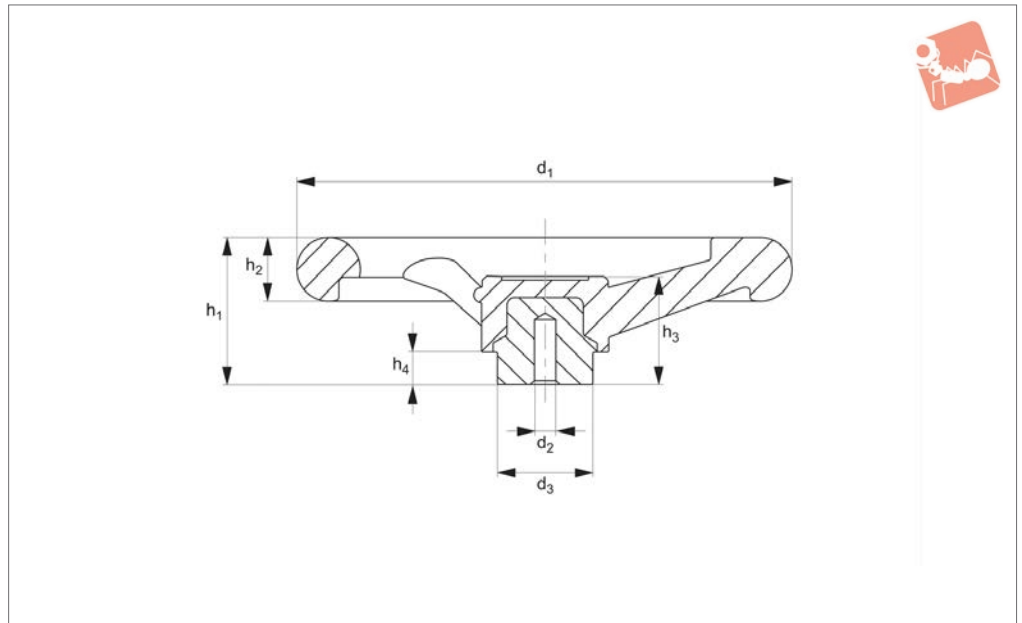

Material

Standard: Duroplast, black. Zinc plated steel hub.

Reinforced: Duroplast with glass fibre

beads of increased strength, black zinc plated steel hub.

Technical Notes

The pilot hole allows various sizes of holes, keyways etc. to be machined into the boss.

Order No.

- 77010.W0100
- 77010.W0125
- 77010.W0150
- 77010.W0175
- 77010.W0200
- 77010.W0250
- 77010.W0300
- 77010.W0500
- 77010.W0525
- 77010.W0550
- 77010.W0575
- 77010.W0700
- 77010.W0750
- 77010.W0800



Three Spoked Handwheels with rotating grip

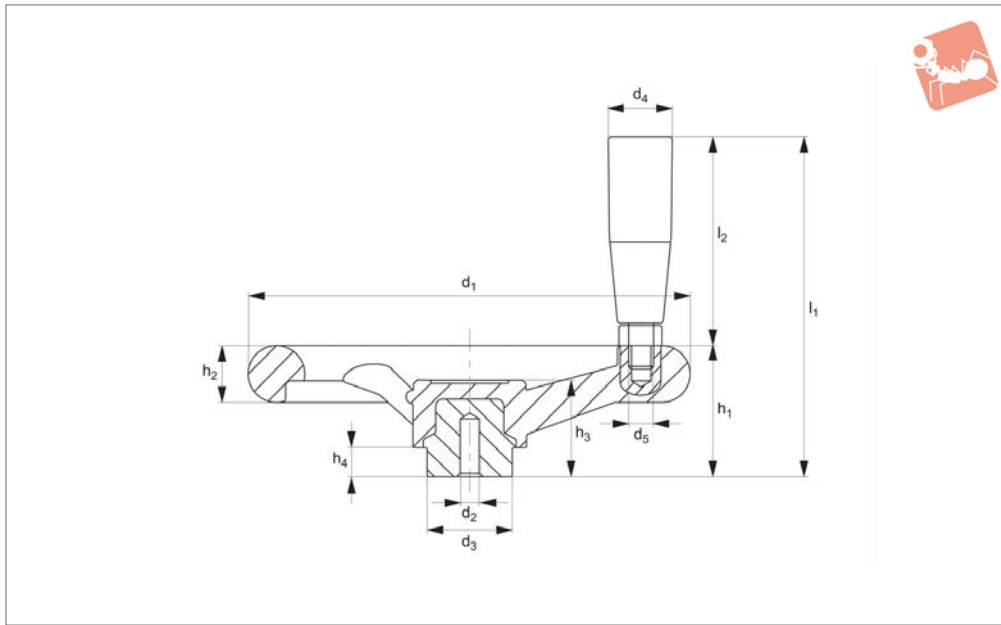

77030

HANDWHEELS

Material

Standard: Duroplast, black. Zinc plated steel hub. Revolving handle.

Reinforced: Duroplast with glass fibre

beads for increased strength, black zinc plated steel auto-revolving handle.

Technical Notes

The pilot hole allows various sizes of holes, keyways etc. to be machined into the hub. Corresponding rotating handle 75100.

Order No.	Type	d ₁	d ₂	d ₃	l ₁	l ₂	h ₁	h ₂	h ₃	h ₄	d ₄	d ₅	Weight g
77030.W0100	Standard	100	4	24	85	40	40	15	34	11	17	M 8	189
77030.W0125	Standard	125	6	24	107	55	46	17	37	13	23	M 8	300
77030.W0150	Standard	150	6	32	120	65	49	20	38	13	25	M10	470
77030.W0175	Standard	175	6	40	127	65	56	22	42	16	25	M10	695
77030.W0200	Standard	200	8	40	153	85	61	24	45	16	28	M10	880
77030.W0250	Standard	250	10	48	164	85	72	28	50	17	28	M10	1335
77030.W0300	Standard	300	10	58	170	85	78	34	56	18	28	M10	2165
77030.W0500	Reinforced	100	4	24	85	40	40	15	34	11	17	M 8	191
77030.W0525	Reinforced	125	6	24	107	55	46	17	37	13	23	M 8	309
77030.W0550	Reinforced	150	6	32	120	65	49	20	38	13	25	M10	484
77030.W0575	Reinforced	175	6	40	127	65	56	22	42	16	25	M10	694
77030.W0700	Reinforced	200	8	40	153	85	61	24	45	16	28	M10	897
77030.W0750	Reinforced	250	10	48	164	85	72	28	50	17	28	M10	1367
77030.W0800	Reinforced	300	10	58	170	85	78	34	56	18	28	M10	2130



77040

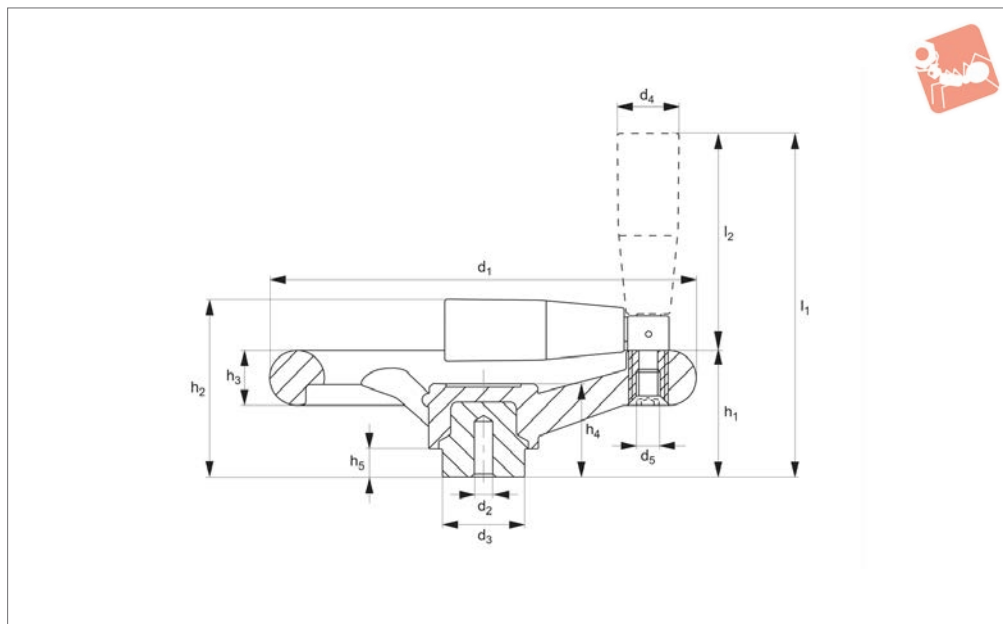

Material

Duroplast, black. Zinc plated steel hub.
With fold-away revolving grip.

Technical Notes

The pilot hole allows various sizes of holes,
keyways etc. to be machined into the hub.

Corresponding rotating handle 75150.

Order No.	d ₁	d ₂	d ₃	l ₁	l ₂	h ₁	h ₂	h ₃	h ₄	h ₅	d ₄	d ₅	Weight g
77040.W0125	125	6	24	118	55	46	66	17	37	13	23	M 5	322
77040.W0150	150	6	32	131	65	49	70	20	38	13	25	M 6	487
77040.W0175	175	6	40	138	65	56	77	22	42	16	25	M 6	698
77040.W0200	200	6	40	166	85	61	85	24	45	16	28	M 6	910
77040.W0250	250	8	48	177	85	72	96	28	50	17	28	M 6	1380
77040.W0300	300	8	58	183	85	78	102	34	56	18	28	M 6	2142

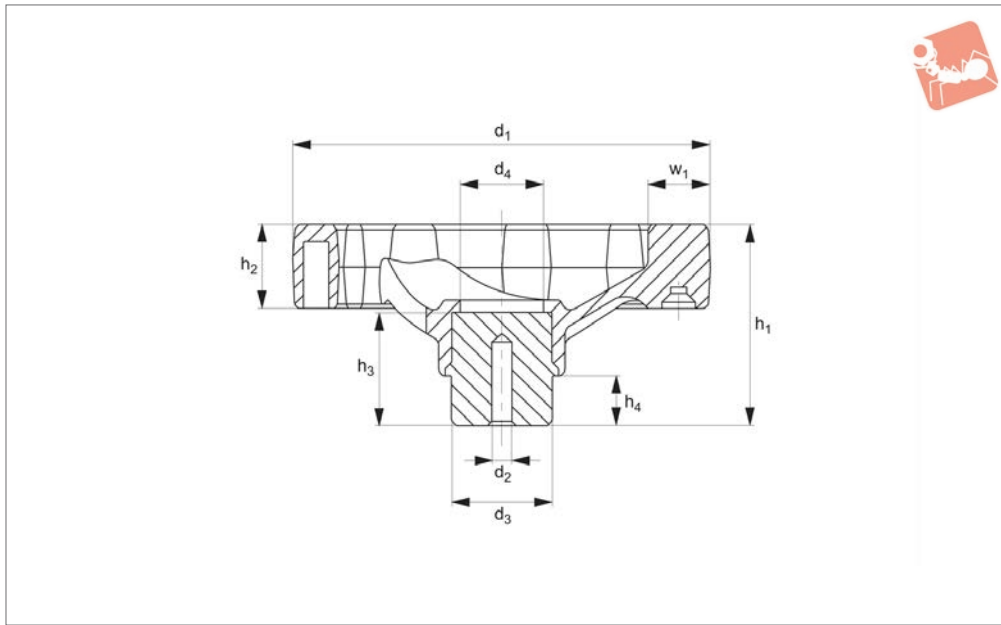

77060

HANDWHEELS

Material

Black, matt, thermoplastic, with zinc plated steel hub.

Technical Notes

The pilot hole allows various sizes of holes, keyways etc. to be machined into the hub.

Order No.	d ₁	d ₂	d ₃	h ₁	h ₂	h ₃	h ₄	d ₄	w ₁	Weight g
77060.W0100	100	4	24	46	20	24	12	18	15	150
77060.W0125	125	6	24	51	24	28	12	20	17	241
77060.W0160	160	6	32	61	28	31	15	30	20	444
77060.W0200	200	6	40	74	32	40	15	35	24	834



77070

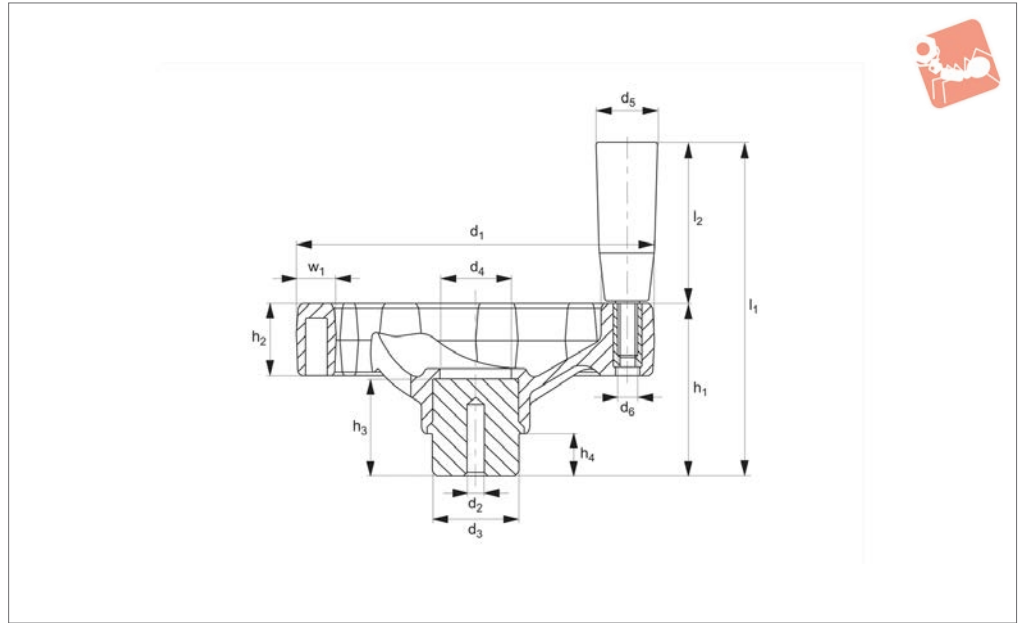

Material

Thermoplastic, black, matt. Zinc plated steel hub. Revolving handle.

Technical Notes

The pilot hole allows various sizes of holes, keyways etc. to be machined into the hub.

Order No.	d ₁	d ₂	d ₃	l ₁	l ₂	h ₁	h ₂	h ₃	h ₄	d ₄	d ₅	d ₆	w ₁	Weight g
77070.W0100	100	4	24	96	50	46	20	24	12	18	21	M 6	15	192
77070.W0125	125	6	24	101	50	51	24	28	12	20	21	M 6	17	261
77070.W0160	160	6	32	131	70	61	28	31	15	30	23	M 8	20	484
77070.W0200	200	6	40	164	90	74	32	40	15	35	26	M10	24	906



Three Spoked Handwheels with fold-away rotating grip

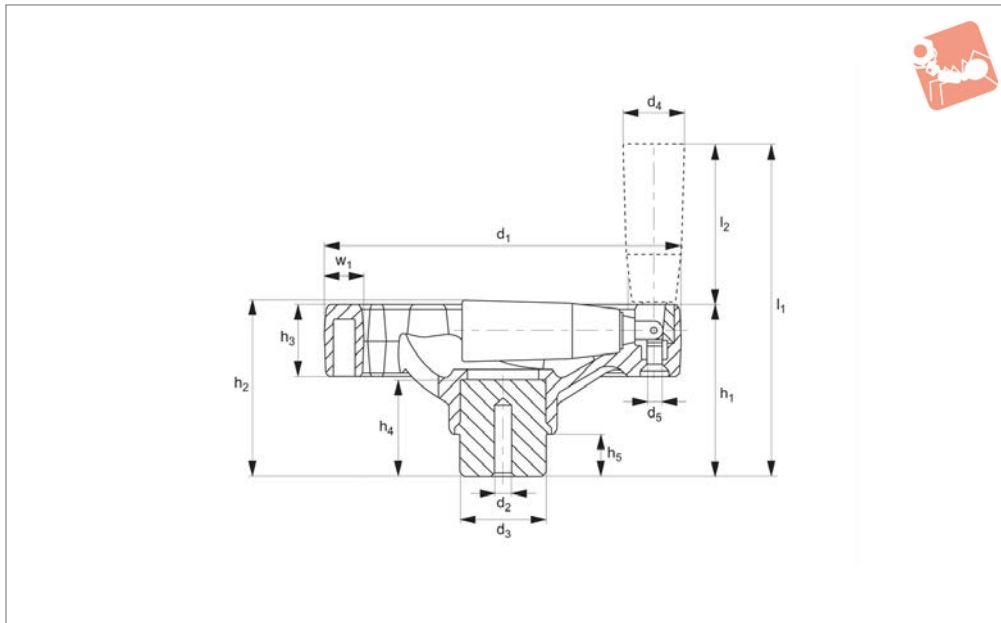

77080

HANDWHEELS

Material

Thermoplastic, black, matt. Zinc plated steel hub. Fold-away revolving handle.

Technical Notes

The pilot hole allows various sizes of holes, keyways etc. to be machined into the hub.

Order No.	d ₁	d ₂	d ₃	l ₁	l ₂	h ₁	h ₂	h ₃	h ₄	h ₅	d ₄	d ₅	w ₁	Weight g
77080.W0100	100	4	24	100	54	46	50	20	24	12	21	M 4	15	205
77080.W0125	125	6	24	105	54	51	54	24	28	12	21	M 4	17	277
77080.W0160	160	6	32	135	74	61	65	28	31	15	23	M 5	20	503
77080.W0200	200	6	40	168	94	74	79	32	40	15	26	M 6	24	935



77100

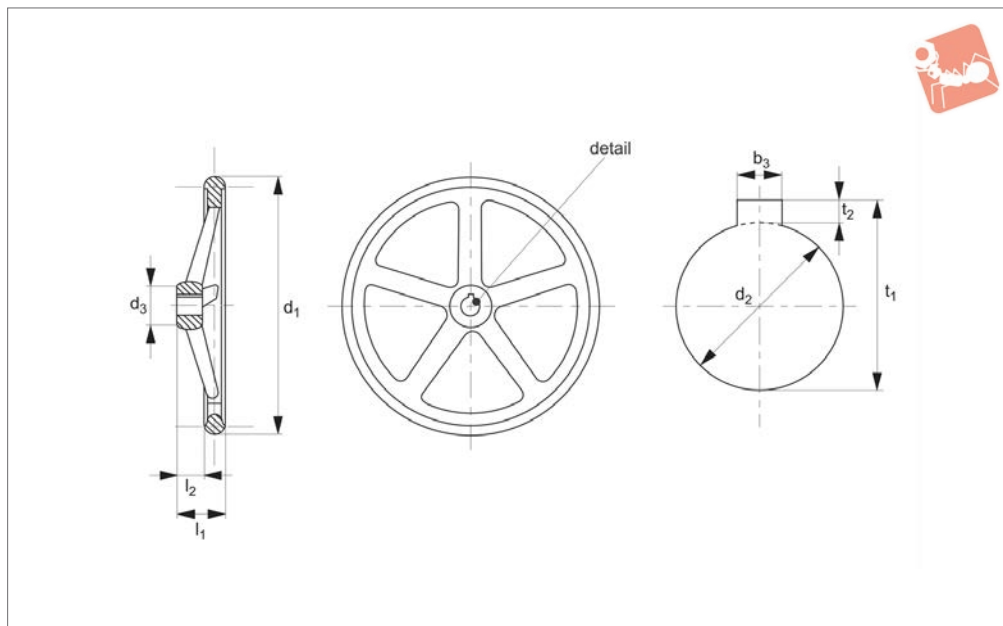

Material

Handwheel: Grey cast iron GG.
Hub machined; rim turned and mirror-finished on all sides, non-machined

surfaces cleanly blasted.

Technical Notes

Produced to DIN 950.

There are gripping indentations on the rear sides.

For keyways information (dim. t_1 and b_3) to DIN 6885.

Order No.	Type	Bore dia.	d_1	d_2 tol. H7 Small	d_2 tol. H7 Large	d_3	l_1 ≈	l_2	No. of spokes	Corresp. handle dia.	Weight g
77100.W0000	W/o Keyway, W/o Handle	d_2 Small	80	10	12	24	29	16	3		311
77100.W0001	W/o Keyway, W/o Handle	d_2 Large	80	10	12	24	29	16	3		311
77100.W0005	W/o Keyway, W/o Handle	d_2 Small	100	10	12	26	33	17	3		486
77100.W0006	W/o Keyway, W/o Handle	d_2 Large	100	10	12	26	33	17	3		486
77100.W0010	W/o Keyway, W/o Handle	d_2 Small	125	12	14	28	36	18	3		720
77100.W0011	W/o Keyway, W/o Handle	d_2 Large	125	12	14	28	36	18	3		720
77100.W0015	W/o Keyway, W/o Handle	d_2 Small	140	14	16	30	39	19	3		879
77100.W0016	W/o Keyway, W/o Handle	d_2 Large	140	14	16	30	39	19	3		879
77100.W0020	W/o Keyway, W/o Handle	d_2 Small	160	14	16	32	40	20	3		1151
77100.W0021	W/o Keyway, W/o Handle	d_2 Large	160	14	16	32	40	20	3		1151
77100.W0030	W/o Keyway, W/o Handle	d_2 Small	200	18	22	38	45	24	3		2218
77100.W0031	W/o Keyway, W/o Handle	d_2 Large	200	18	22	38	45	24	3		2218
77100.W0040	W/o Keyway, W/o Handle	d_2 Small	250	22	26	45	50	28	5		3735
77100.W0041	W/o Keyway, W/o Handle	d_2 Large	250	22	26	45	50	28	5		3735
77100.W0045	W/o Keyway, W/o Handle	d_2 Small	315	26	30	53	56	33	5		6180
77100.W0046	W/o Keyway, W/o Handle	d_2 Large	315	26	30	53	56	33	5		6180
77100.W0050	W/o Keyway, W/o Handle	d_2 Small	400	30	34	65	63	38	5		9500
77100.W0051	W/o Keyway, W/o Handle	d_2 Large	400	30	34	65	63	38	5		9500
77100.W0100	With Keyway, W/o Handle	d_2 Small	80	10	12	24	29	16	3		360
77100.W0101	With Keyway, W/o Handle	d_2 Large	80	10	12	24	29	16	3		360
77100.W0105	With Keyway, W/o Handle	d_2 Small	100	10	12	26	33	17	3		500
77100.W0106	With Keyway, W/o Handle	d_2 Large	100	10	12	26	33	17	3		500
77100.W0110	With Keyway, W/o Handle	d_2 Small	125	12	14	28	36	18	3		750
77100.W0111	With Keyway, W/o Handle	d_2 Large	125	12	14	28	36	18	3		750
77100.W0115	With Keyway, W/o Handle	d_2 Small	140	14	16	30	39	19	3		902
77100.W0116	With Keyway, W/o Handle	d_2 Large	140	14	16	30	39	19	3		902
77100.W0120	With Keyway, W/o Handle	d_2 Small	160	14	16	32	40	20	3		1139
77100.W0121	With Keyway, W/o Handle	d_2 Large	160	14	16	32	40	20	3		1139
77100.W0130	With Keyway, W/o Handle	d_2 Small	200	18	22	38	45	24	3		2142
77100.W0131	With Keyway, W/o Handle	d_2 Large	200	18	22	38	45	24	3		2142
77100.W0140	With Keyway, W/o Handle	d_2 Small	250	22	26	45	50	28	5		3652
77100.W0141	With Keyway, W/o Handle	d_2 Large	250	22	26	45	50	28	5		3652
77100.W0145	With Keyway, W/o Handle	d_2 Small	315	26	30	53	56	33	5		5800

Cast Iron Handwheels



Handwheels

Order No.	Type	Bore dia.	d ₁	d ₂ tol. H7 Small	d ₂ tol. H7 Large	d ₃	l ₁ ≈	l ₂	No. of spokes	Corresp. handle dia.	Weight g
77100.W0146	With Keyway, W/o Handle	d ₂ Large	315	26	30	53	56	33	5		5800
77100.W0150	With Keyway, W/o Handle	d ₂ Small	400	30	34	65	63	38	5		9500
77100.W0151	With Keyway, W/o Handle	d ₂ Large	400	30	34	65	63	38	5		9500
77100.W0200	W/o Keyway, Rotating Handle	d ₂ Small	80	10	12	24	29	16	3	16	410
77100.W0201	W/o Keyway, Rotating Handle	d ₂ Large	80	10	12	24	29	16	3	16	410
77100.W0205	W/o Keyway, Rotating Handle	d ₂ Small	100	10	12	26	33	17	3	16	550
77100.W0206	W/o Keyway, Rotating Handle	d ₂ Large	100	10	12	26	33	17	3	16	550
77100.W0210	W/o Keyway, Rotating Handle	d ₂ Small	125	12	14	28	36	18	3	20	850
77100.W0211	W/o Keyway, Rotating Handle	d ₂ Large	125	12	14	28	36	18	3	20	850
77100.W0215	W/o Keyway, Rotating Handle	d ₂ Small	140	14	16	30	39	19	3	20	1040
77100.W0216	W/o Keyway, Rotating Handle	d ₂ Large	140	14	16	30	39	19	3	20	1040
77100.W0220	W/o Keyway, Rotating Handle	d ₂ Small	160	14	16	32	40	20	3	25	1390
77100.W0221	W/o Keyway, Rotating Handle	d ₂ Large	160	14	16	32	40	20	3	25	1390
77100.W0230	W/o Keyway, Rotating Handle	d ₂ Small	200	18	22	38	45	24	3	25	2190
77100.W0231	W/o Keyway, Rotating Handle	d ₂ Large	200	18	22	38	45	24	3	25	2190
77100.W0240	W/o Keyway, Rotating Handle	d ₂ Small	250	22	26	45	50	28	5	32	4185
77100.W0241	W/o Keyway, Rotating Handle	d ₂ Large	250	22	26	45	50	28	5	32	4185
77100.W0245	W/o Keyway, Rotating Handle	d ₂ Small	315	26	30	53	56	33	5	32	6185
77100.W0246	W/o Keyway, Rotating Handle	d ₂ Large	315	26	30	53	56	33	5	32	6185
77100.W0250	W/o Keyway, Rotating Handle	d ₂ Small	400	30	34	65	63	38	5	36	10500
77100.W0251	W/o Keyway, Rotating Handle	d ₂ Large	400	30	34	65	63	38	5	36	10500
77100.W0300	With Keyway, Rotating Handle	d ₂ Small	80	10	12	24	29	16	3	16	410
77100.W0301	With Keyway, Rotating Handle	d ₂ Large	80	10	12	24	29	16	3	16	410
77100.W0305	With Keyway, Rotating Handle	d ₂ Small	100	10	12	26	33	17	3	16	550
77100.W0306	With Keyway, Rotating Handle	d ₂ Large	100	10	12	26	33	17	3	16	550
77100.W0310	With Keyway, Rotating Handle	d ₂ Small	125	12	14	28	36	18	3	20	850
77100.W0311	With Keyway, Rotating Handle	d ₂ Large	125	12	14	28	36	18	3	20	850
77100.W0315	With Keyway, Rotating Handle	d ₂ Small	140	14	16	30	39	19	3	20	1040
77100.W0316	With Keyway, Rotating Handle	d ₂ Large	140	14	16	30	39	19	3	20	1040
77100.W0320	With Keyway, Rotating Handle	d ₂ Small	160	14	16	32	40	20	3	25	1390
77100.W0321	With Keyway, Rotating Handle	d ₂ Large	160	14	16	32	40	20	3	25	1390
77100.W0330	With Keyway, Rotating Handle	d ₂ Small	200	18	22	38	45	24	3	25	2190
77100.W0331	With Keyway, Rotating Handle	d ₂ Large	200	18	22	38	45	24	3	25	2190
77100.W0340	With Keyway, Rotating Handle	d ₂ Small	250	22	26	45	50	28	5	32	4185
77100.W0341	With Keyway, Rotating Handle	d ₂ Large	250	22	26	45	50	28	5	32	4185
77100.W0345	With Keyway, Rotating Handle	d ₂ Small	315	26	30	53	56	33	5	32	6185
77100.W0346	With Keyway, Rotating Handle	d ₂ Large	315	26	30	53	56	33	5	32	6185
77100.W0350	With Keyway, Rotating Handle	d ₂ Small	400	30	34	65	63	38	5	36	10500
77100.W0351	With Keyway, Rotating Handle	d ₂ Large	400	30	34	65	63	38	5	36	10500
77100.W0400	W/o Keyway, Fixed Handle	d ₂ Small	80	10	12	24	29	16	3	16	410
77100.W0401	W/o Keyway, Fixed Handle	d ₂ Large	80	10	12	24	29	16	3	16	410
77100.W0410	W/o Keyway, Fixed Handle	d ₂ Small	125	10	12	28	36	18	3	20	835
77100.W0411	W/o Keyway, Fixed Handle	d ₂ Large	125	10	12	28	36	18	3	20	835
77100.W0415	W/o Keyway, Fixed Handle	d ₂ Small	140	12	14	30	39	19	3	20	1025
77100.W0416	W/o Keyway, Fixed Handle	d ₂ Large	140	12	14	30	39	19	3	20	1025
77100.W0420	W/o Keyway, Fixed Handle	d ₂ Small	160	14	16	32	40	20	3	25	1380
77100.W0421	W/o Keyway, Fixed Handle	d ₂ Large	160	14	16	32	40	20	3	25	1380
77100.W0430	W/o Keyway, Fixed Handle	d ₂ Small	200	14	16	38	45	24	3	25	2180
77100.W0431	W/o Keyway, Fixed Handle	d ₂ Large	200	14	16	38	45	24	3	25	2180
77100.W0440	W/o Keyway, Fixed Handle	d ₂ Small	250	18	22	45	50	28	5	32	4160
77100.W0441	W/o Keyway, Fixed Handle	d ₂ Large	250	18	22	45	50	28	5	32	4160
77100.W0445	W/o Keyway, Fixed Handle	d ₂ Small	315	22	26	53	56	33	5	32	6160
77100.W0446	W/o Keyway, Fixed Handle	d ₂ Large	315	22	26	53	56	33	5	32	6160
77100.W0450	W/o Keyway, Fixed Handle	d ₂ Small	400	26	30	65	63	38	5	36	10460
77100.W0451	W/o Keyway, Fixed Handle	d ₂ Large	400	26	30	65	63	38	5	36	10460
77100.W0500	With Keyway, Fixed Handle	d ₂ Small	80	30	34	24	29	16	3	16	410
77100.W0501	With Keyway, Fixed Handle	d ₂ Large	80	30	34	24	29	16	3	16	410
77100.W0505	With Keyway, Fixed Handle	d ₂ Small	100	10	12	26	33	17	3	16	550
77100.W0506	With Keyway, Fixed Handle	d ₂ Large	100	10	12	26	33	17	3	16	550
77100.W0510	With Keyway, Fixed Handle	d ₂ Small	125	10	12	28	36	18	3	20	835
77100.W0511	With Keyway, Fixed Handle	d ₂ Large	125	10	12	28	36	18	3	20	835
77100.W0515	With Keyway, Fixed Handle	d ₂ Small	140	12	14	30	39	19	3	20	1025
77100.W0516	With Keyway, Fixed Handle	d ₂ Large	140	12	14	30	39	19	3	20	1025
77100.W0520	With Keyway, Fixed Handle	d ₂ Small	160	14	16	32	40	20	3	25	1380
77100.W0521	With Keyway, Fixed Handle	d ₂ Large	160	14	16	32	40	20	3	25	1380
77100.W0530	With Keyway, Fixed Handle	d ₂ Small	200	18	22	38	45	24	3	25	2180
77100.W0531	With Keyway, Fixed Handle	d ₂ Large	200	18	22	38	45	24	3	25	2180

HANDWHEELS



Order No.	Type	Bore dia.	d_1	d_2 tol. H7 Small	d_2 tol. H7 Large	d_3	l_1 ≈	l_2	No. of spokes	Corresp. handle dia.	Weight g
77100.W0540	With Keyway, Fixed Handle	d_2 Small	250	22	26	45	50	28	5	32	4160
77100.W0541	With Keyway, Fixed Handle	d_2 Large	250	22	26	45	50	28	5	32	4160
77100.W0545	With Keyway, Fixed Handle	d_2 Small	315	26	30	53	56	33	5	32	6160
77100.W0546	With Keyway, Fixed Handle	d_2 Large	315	26	30	53	56	33	5	32	6160
77100.W0550	With Keyway, Fixed Handle	d_2 Small	400	30	34	65	63	38	5	36	10460
77100.W0551	With Keyway, Fixed Handle	d_2 Large	400	30	34	65	63	38	5	36	10460

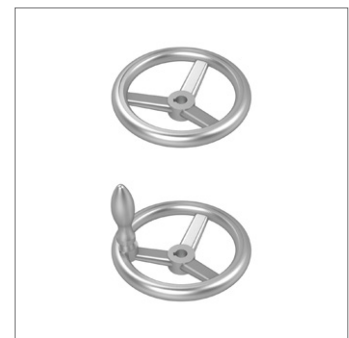
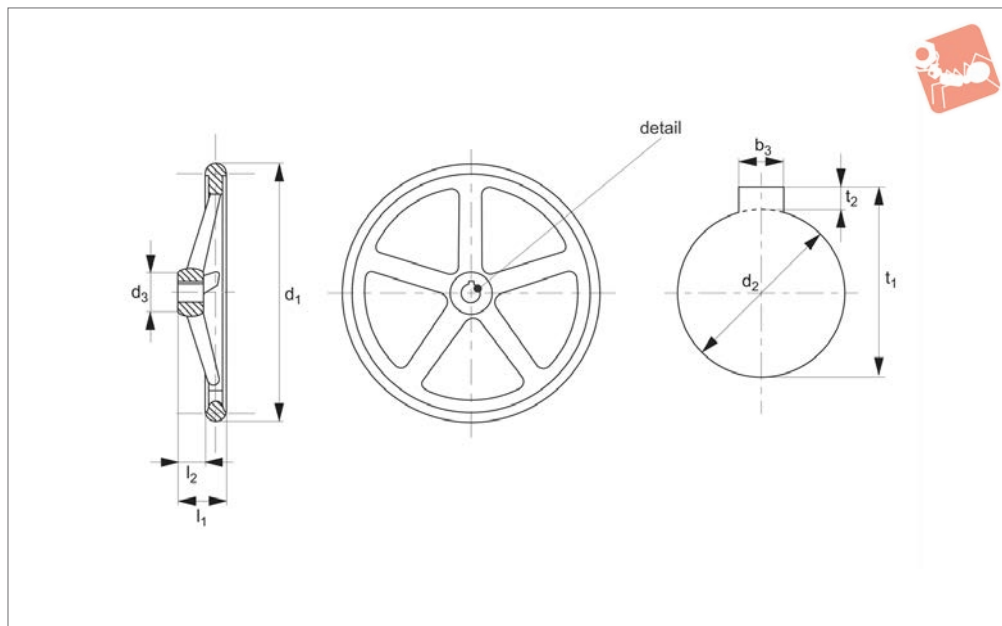

77120

HANDWHEELS

Material

Aluminium, deburred. Hub machined, rim polished. For corresponding handle details

see no. 75060.

Technical Notes

Produced to DIN 950.

For keyways information (dim. t_1 and b_3) to DIN 6885.

Order No.	Type	Bore dia.	d_1	d_2 tol. H7 Small	d_2 tol. H7 Large	d_3	l_1 ≈	l_2	No. of spokes	Corresp. handle dia.	Weight g
77120.W0000	W/o Keyway, W/o Handle	d_2 Small	80	10	12	24	29	16	3		92
77120.W0001	W/o Keyway, W/o Handle	d_2 Large	80	10	12	24	29	16	3		92
77120.W0005	W/o Keyway, W/o Handle	d_2 Small	100	10	12	26	33	17	3		160
77120.W0006	W/o Keyway, W/o Handle	d_2 Large	100	10	12	26	33	17	3		160
77120.W0010	W/o Keyway, W/o Handle	d_2 Small	125	12	14	28	36	18	3		237
77120.W0011	W/o Keyway, W/o Handle	d_2 Large	125	12	14	28	36	18	3		237
77120.W0015	W/o Keyway, W/o Handle	d_2 Small	140	14	16	30	39	19	3		295
77120.W0016	W/o Keyway, W/o Handle	d_2 Large	140	14	16	30	39	19	3		295
77120.W0020	W/o Keyway, W/o Handle	d_2 Small	160	14	16	32	40	20	3		435
77120.W0021	W/o Keyway, W/o Handle	d_2 Large	160	14	16	32	40	20	3		435
77120.W0030	W/o Keyway, W/o Handle	d_2 Small	200	18	22	38	45	24	3		783
77120.W0031	W/o Keyway, W/o Handle	d_2 Large	200	18	22	38	45	24	3		783
77120.W0040	W/o Keyway, W/o Handle	d_2 Small	250	22	26	45	50	28	5		1509
77120.W0041	W/o Keyway, W/o Handle	d_2 Large	250	22	26	45	50	28	5		1509
77120.W0045	W/o Keyway, W/o Handle	d_2 Small	315	26	30	53	56	33	5		2440
77120.W0046	W/o Keyway, W/o Handle	d_2 Large	315	26	30	53	56	33	5		2440
77120.W0050	W/o Keyway, W/o Handle	d_2 Small	400	30	34	65	63	38	5		3740
77120.W0051	W/o Keyway, W/o Handle	d_2 Large	400	30	34	65	63	38	5		3740
77120.W0100	With Keyway, W/o Handle	d_2 Small	80	10	12	24	29	16	3		99
77120.W0101	With Keyway, W/o Handle	d_2 Large	80	10	12	24	29	16	3		99
77120.W0105	With Keyway, W/o Handle	d_2 Small	100	10	12	26	33	17	3		171
77120.W0106	With Keyway, W/o Handle	d_2 Large	100	10	12	26	33	17	3		171
77120.W0110	With Keyway, W/o Handle	d_2 Small	125	12	14	28	36	18	3		232
77120.W0111	With Keyway, W/o Handle	d_2 Large	125	12	14	28	36	18	3		232
77120.W0115	With Keyway, W/o Handle	d_2 Small	140	14	16	30	39	19	3		309
77120.W0116	With Keyway, W/o Handle	d_2 Large	140	14	16	30	39	19	3		309
77120.W0120	With Keyway, W/o Handle	d_2 Small	160	14	16	32	40	20	3		422
77120.W0121	With Keyway, W/o Handle	d_2 Large	160	14	16	32	40	20	3		422
77120.W0130	With Keyway, W/o Handle	d_2 Small	200	18	22	38	45	24	3		779
77120.W0131	With Keyway, W/o Handle	d_2 Large	200	18	22	38	45	24	3		779
77120.W0140	With Keyway, W/o Handle	d_2 Small	250	22	26	45	50	28	5		1511
77120.W0141	With Keyway, W/o Handle	d_2 Large	250	22	26	45	50	28	5		1511
77120.W0145	With Keyway, W/o Handle	d_2 Small	315	26	30	53	56	33	5		2500
77120.W0146	With Keyway, W/o Handle	d_2 Large	315	26	30	53	56	33	5		2500



HANDWHEELS

Order No.	Type	Bore dia.	d ₁	d ₂ tol. H7 Small	d ₂ tol. H7 Large	d ₃	l ₁ ≈	l ₂	No. of spokes	Corresp. handle dia.	Weight g
77120.W0150	With Keyway, W/o Handle	d ₂ Small	400	30	34	65	63	38	5		3600
77120.W0151	With Keyway, W/o Handle	d ₂ Large	400	30	34	65	63	38	5		3600
77120.W0200	W/o Keyway, Rotating Handle	d ₂ Small	80	10	12	24	29	16	3	16	150
77120.W0201	W/o Keyway, Rotating Handle	d ₂ Large	80	10	12	24	29	16	3	16	150
77120.W0205	W/o Keyway, Rotating Handle	d ₂ Small	100	10	12	26	33	17	3	16	210
77120.W0206	W/o Keyway, Rotating Handle	d ₂ Large	100	10	12	26	33	17	3	16	210
77120.W0210	W/o Keyway, Rotating Handle	d ₂ Small	125	12	14	28	36	18	3	20	340
77120.W0211	W/o Keyway, Rotating Handle	d ₂ Large	125	12	14	28	36	18	3	20	340
77120.W0215	W/o Keyway, Rotating Handle	d ₂ Small	140	14	16	30	39	19	3	20	430
77120.W0216	W/o Keyway, Rotating Handle	d ₂ Large	140	14	16	30	39	19	3	20	430
77120.W0220	W/o Keyway, Rotating Handle	d ₂ Small	160	14	16	32	40	20	3	25	615
77120.W0221	W/o Keyway, Rotating Handle	d ₂ Large	160	14	16	32	40	20	3	25	615
77120.W0230	W/o Keyway, Rotating Handle	d ₂ Small	200	18	22	38	45	24	3	25	970
77120.W0231	W/o Keyway, Rotating Handle	d ₂ Large	200	18	22	38	45	24	3	25	970
77120.W0240	W/o Keyway, Rotating Handle	d ₂ Small	250	22	26	45	50	28	5	32	1885
77120.W0241	W/o Keyway, Rotating Handle	d ₂ Large	250	22	26	45	50	28	5	32	1885
77120.W0245	W/o Keyway, Rotating Handle	d ₂ Small	315	26	30	53	56	33	5	32	2885
77120.W0246	W/o Keyway, Rotating Handle	d ₂ Large	315	26	30	53	56	33	5	32	2885
77120.W0250	W/o Keyway, Rotating Handle	d ₂ Small	400	30	34	65	63	38	5	36	4250
77120.W0251	W/o Keyway, Rotating Handle	d ₂ Large	400	30	34	65	63	38	5	36	4250
77120.W0300	With Keyway, Rotating Handle	d ₂ Small	80	10	12	24	29	16	3	16	150
77120.W0301	With Keyway, Rotating Handle	d ₂ Large	80	10	12	24	29	16	3	16	150
77120.W0305	With Keyway, Rotating Handle	d ₂ Small	100	10	12	26	33	17	3	16	210
77120.W0306	With Keyway, Rotating Handle	d ₂ Large	100	10	12	26	33	17	3	16	210
77120.W0310	With Keyway, Rotating Handle	d ₂ Small	125	12	14	28	36	18	3	20	340
77120.W0311	With Keyway, Rotating Handle	d ₂ Large	125	12	14	28	36	18	3	20	340
77120.W0315	With Keyway, Rotating Handle	d ₂ Small	140	14	16	30	39	19	3	20	430
77120.W0316	With Keyway, Rotating Handle	d ₂ Large	140	14	16	30	39	19	3	20	430
77120.W0320	With Keyway, Rotating Handle	d ₂ Small	160	14	16	32	40	20	3	25	615
77120.W0321	With Keyway, Rotating Handle	d ₂ Large	160	14	16	32	40	20	3	25	615
77120.W0330	With Keyway, Rotating Handle	d ₂ Small	200	18	22	38	45	24	3	25	970
77120.W0331	With Keyway, Rotating Handle	d ₂ Large	200	18	22	38	45	24	3	25	970
77120.W0340	With Keyway, Rotating Handle	d ₂ Small	250	22	26	45	50	28	5	32	1885
77120.W0341	With Keyway, Rotating Handle	d ₂ Large	250	22	26	45	50	28	5	32	1885
77120.W0345	With Keyway, Rotating Handle	d ₂ Small	315	26	30	53	56	33	5	32	2885
77120.W0346	With Keyway, Rotating Handle	d ₂ Large	315	26	30	53	56	33	5	32	2885
77120.W0350	With Keyway, Rotating Handle	d ₂ Small	400	30	34	65	63	38	5	36	4250
77120.W0351	With Keyway, Rotating Handle	d ₂ Large	400	30	34	65	63	38	5	36	4250
77120.W0400	W/o Keyway, Fixed Handle	d ₂ Small	80	10	12	24	29	16	3	16	150
77120.W0401	W/o Keyway, Fixed Handle	d ₂ Large	80	10	12	24	29	16	3	16	150
77120.W0405	W/o Keyway, Fixed Handle	d ₂ Small	100	10	12	26	33	17	3	16	210
77120.W0406	W/o Keyway, Fixed Handle	d ₂ Large	100	10	12	26	33	17	3	16	210
77120.W0410	W/o Keyway, Fixed Handle	d ₂ Small	125	12	14	28	36	18	3	20	340
77120.W0411	W/o Keyway, Fixed Handle	d ₂ Large	125	12	14	28	36	18	3	20	340
77120.W0415	W/o Keyway, Fixed Handle	d ₂ Small	140	14	16	30	39	19	3	20	420
77120.W0416	W/o Keyway, Fixed Handle	d ₂ Large	140	14	16	30	39	19	3	20	420
77120.W0420	W/o Keyway, Fixed Handle	d ₂ Small	160	14	16	32	40	20	3	25	615
77120.W0421	W/o Keyway, Fixed Handle	d ₂ Large	160	14	16	32	40	20	3	25	615
77120.W0430	W/o Keyway, Fixed Handle	d ₂ Small	200	18	22	38	45	24	3	25	970
77120.W0431	W/o Keyway, Fixed Handle	d ₂ Large	200	18	22	38	45	24	3	25	970
77120.W0440	W/o Keyway, Fixed Handle	d ₂ Small	250	22	26	45	50	28	5	32	1860
77120.W0441	W/o Keyway, Fixed Handle	d ₂ Large	250	22	26	45	50	28	5	32	1860
77120.W0445	W/o Keyway, Fixed Handle	d ₂ Small	315	26	30	53	56	33	5	32	2860
77120.W0446	W/o Keyway, Fixed Handle	d ₂ Large	315	26	30	53	56	33	5	32	2860
77120.W0450	W/o Keyway, Fixed Handle	d ₂ Small	400	30	34	65	63	38	5	36	4210
77120.W0451	W/o Keyway, Fixed Handle	d ₂ Large	400	30	34	65	63	38	5	36	4210
77120.W0500	With Keyway, Fixed Handle	d ₂ Small	80	10	12	24	29	16	3	16	150
77120.W0501	With Keyway, Fixed Handle	d ₂ Large	80	10	12	24	29	16	3	16	150
77120.W0505	With Keyway, Fixed Handle	d ₂ Small	100	10	12	26	33	17	3	16	210
77120.W0506	With Keyway, Fixed Handle	d ₂ Large	100	10	12	26	33	17	3	16	210
77120.W0510	With Keyway, Fixed Handle	d ₂ Small	125	12	14	28	36	18	3	20	330
77120.W0511	With Keyway, Fixed Handle	d ₂ Large	125	12	14	28	36	18	3	20	330
77120.W0515	With Keyway, Fixed Handle	d ₂ Small	140	14	16	30	39	19	3	20	420
77120.W0516	With Keyway, Fixed Handle	d ₂ Large	140	14	16	30	39	19	3	20	420
77120.W0520	With Keyway, Fixed Handle	d ₂ Small	160	14	16	32	40	20	3	25	610
77120.W0521	With Keyway, Fixed Handle	d ₂ Large	160	14	16	32	40	20	3	25	610
77120.W0530	With Keyway, Fixed Handle	d ₂ Small	200	18	22	38	45	24	3	25	960

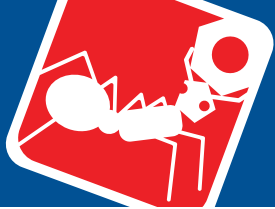

Aluminium Handwheels



Handwheels

Order No.	Type	Bore dia.	d ₁	d ₂ tol. H7 Small	d ₂ tol. H7 Large	d ₃	l ₁ ≈	l ₂	No. of spokes	Corresp. handle dia.	Weight g
77120.W0531	With Keyway, Fixed Handle	d ₂ Large	200	18	22	38	45	24	3	25	960
77120.W0540	With Keyway, Fixed Handle	d ₂ Small	250	22	26	45	50	28	5	32	1860
77120.W0541	With Keyway, Fixed Handle	d ₂ Large	250	22	26	45	50	28	5	32	1860
77120.W0545	With Keyway, Fixed Handle	d ₂ Small	315	26	30	53	56	33	5	32	2860
77120.W0546	With Keyway, Fixed Handle	d ₂ Large	315	26	30	53	56	33	5	32	2860
77120.W0550	With Keyway, Fixed Handle	d ₂ Small	400	30	34	65	65	38	5	36	4210
77120.W0551	With Keyway, Fixed Handle	d ₂ Large	400	30	34	65	65	38	5	36	4210

HANDWHEELS



77140

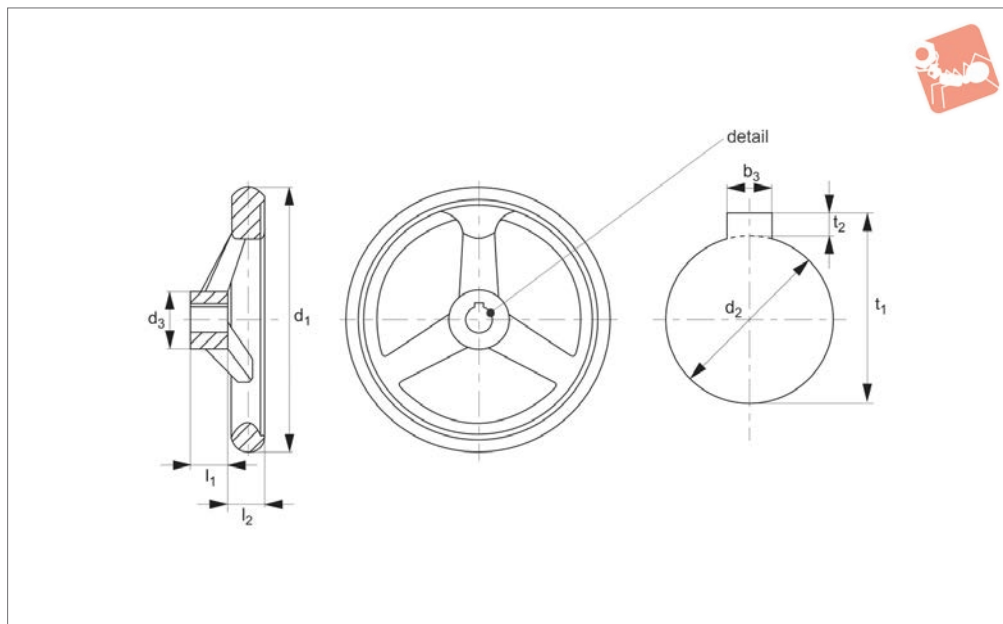

Material

Stainless steel, deburred.
Hub machined; rim turned and mirror-finished on all sides, non-machined

surfaces cleanly blasted.

to DIN 6885.

Technical Notes

For keyways information (dim. t_1 and b_3)

Order No.	Finish	d_1	d_2 tol. h9	d_3	l_1	l_2	No. of spokes	Machine handles dia.	Weight g
77140.W0005	W/o Keyway, W/o Handle	100	10	25.5	17	14.5	3	-	431
77140.W0010	W/o Keyway, W/o Handle	125	12	27.0	18	15.8	3	-	655
77140.W0015	W/o Keyway, W/o Handle	140	14	29.0	19	17.0	3	-	851
77140.W0020	W/o Keyway, W/o Handle	160	14	27.0	18	17.5	3	-	1112
77140.W0030	W/o Keyway, W/o Handle	200	18	37.0	24	20.0	3	-	1877
77140.W0105	With Keyway, W/o Handle	100	10	25.5	17	14.5	3	-	434
77140.W0110	With Keyway, W/o Handle	125	12	27.0	18	15.8	3	-	854
77140.W0115	With Keyway, W/o Handle	140	14	29.0	19	17.0	3	-	854
77140.W0120	With Keyway, W/o Handle	160	14	31.0	20	17.5	3	-	1115
77140.W0130	With Keyway, W/o Handle	200	18	37.0	24	20.0	3	-	1882
77140.W0405	W/o Keyway, With Handle	100	10	25.5	17	14.5	3	16	472
77140.W0410	W/o Keyway, With Handle	125	12	27.0	18	15.8	3	20	748
77140.W0415	W/o Keyway, With Handle	140	14	29.0	19	17.0	3	20	939
77140.W0420	W/o Keyway, With Handle	160	14	31.0	20	17.5	3	25	1273
77140.W0430	W/o Keyway, With Handle	200	18	37.0	24	20.0	3	25	2044
77140.W0505	With Keyway, With Handle	100	10	25.5	17	14.5	3	16	473
77140.W0510	With Keyway, With Handle	125	12	27.0	18	15.8	3	20	753
77140.W0515	With Keyway, With Handle	140	14	29.0	19	17.0	3	20	939
77140.W0520	With Keyway, With Handle	160	14	31.0	20	17.5	3	25	1282
77140.W0530	With Keyway, With Handle	200	18	37.0	24	20.0	3	25	2049

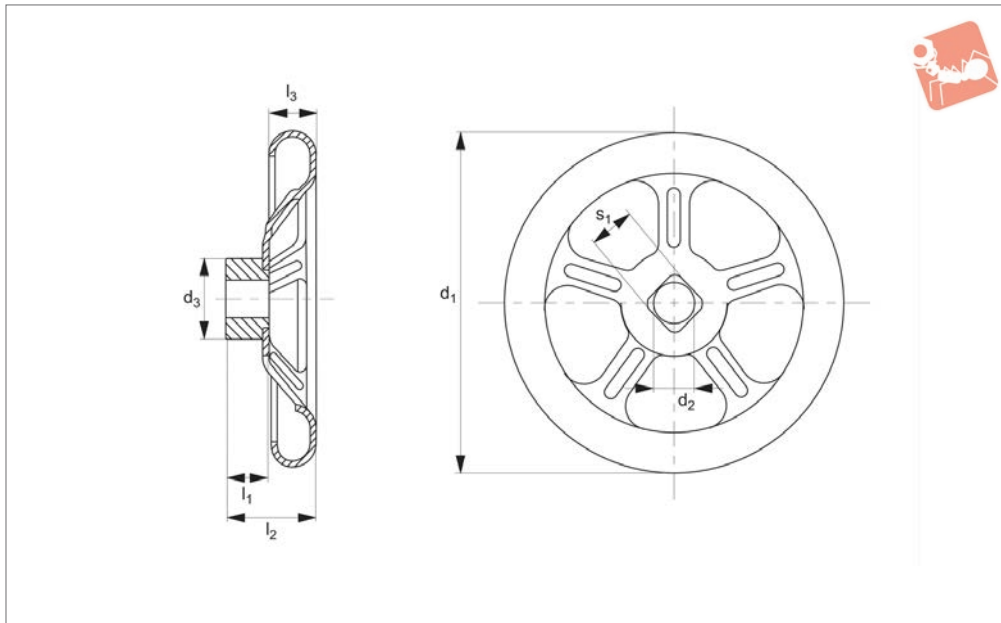

77420

HANDWHEELS

Material

Pressed steel, plastic coated.
Black - RAL9005.

Technical Notes

This plastic coated handwheel is resistant to shock and impacts, is well designed and

cost effective.

Order No.	Bore dia.	d ₁	d ₂ round tol. H9	d ₃	l ₁	l ₂ ≈	l ₃	No. of spokes	s ₁ square tol. H11	Weight g
77420.W0010	Round	125	B11	30	18	29	18	3	V11	300
77420.W0012	Round	160	B12	30	20	37	22	4	V12	400
77420.W0014	Round	200	B14	40	24	46	22	4	V14	800
77420.W0017	Round	250	B17	45	28	52	30	5	V17	1400
77420.W0019	Round	315	B19	55	33	64	35	5	V19	2300
77420.W0021	Round	400	B24	65	38	82	40	5	V24	9140
77420.W0110	Square	125	B11	30	18	29	18	3	V11	300
77420.W0112	Square	160	B12	30	20	37	22	4	V12	400
77420.W0114	Square	200	B14	40	24	46	22	4	V14	800
77420.W0117	Square	250	B17	45	28	52	30	5	V17	1400
77420.W0119	Square	315	B19	55	33	64	35	5	V19	2300
77420.W0121	Square	400	B24	65	38	82	40	5	V24	9140



HANDWHEELS



77430

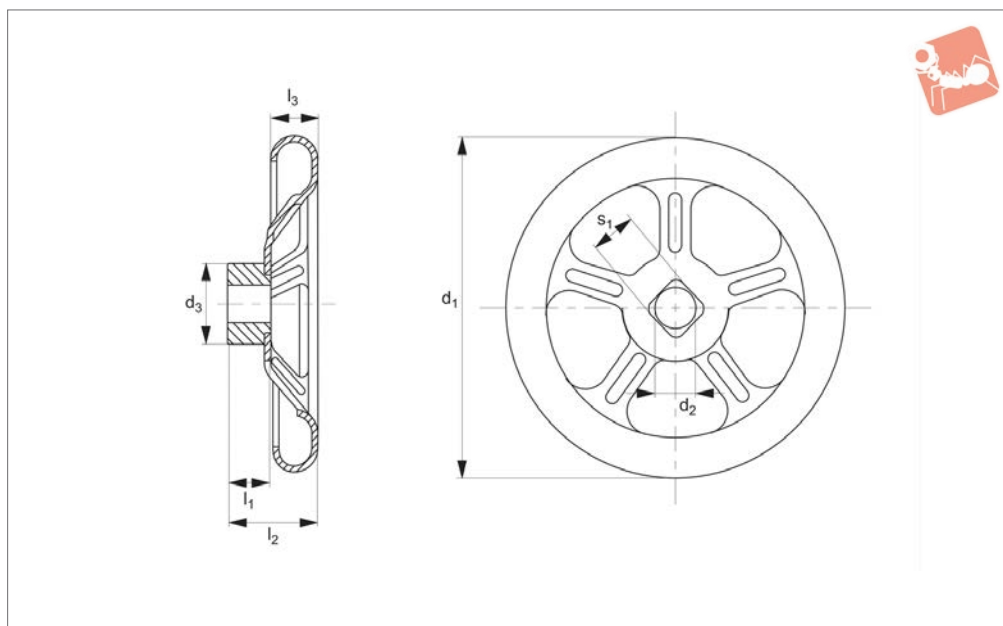

Material

Stainless steel 1.4301 (AISI 303), pressed.
Hub welded. Matte shot-blasted.

Order No.	Bore dia.	d ₁	d ₂ round tol. H9	d ₃	l ₁	l ₂ ≈	l ₃	No. of spokes	s ₁ square tol. H11	Weight g
77430.W0012	Round	160	B12	30	20	39	22	4	V12	430
77430.W0014	Round	200	B14	40	24	44	22	4	V14	824
77430.W0017	Round	250	B17	45	28	52	30	5	V17	1477
77430.W0112	Square	160	B12	30	20	39	22	4	V12	430
77430.W0114	Square	200	B14	40	24	44	22	4	V14	824
77430.W0117	Square	250	B17	45	28	52	30	5	V17	1477



Disc Type Handwheels

DIN 3670

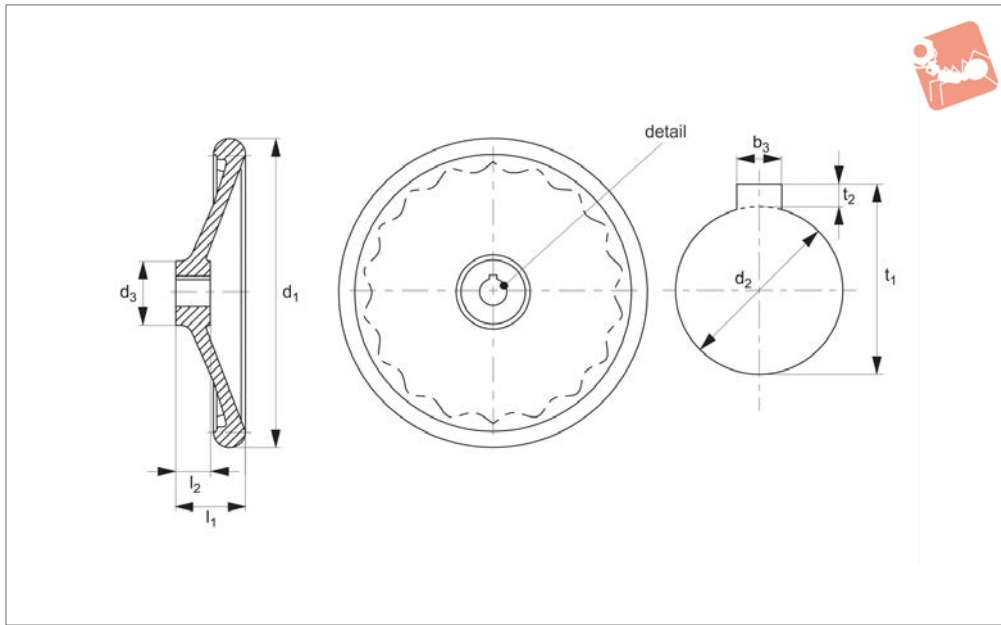

77200

HANDWHEELS

Material

Hub machined; rim turned and mirror-finished on all sides, non-machined surfaces cleanly blasted.

Aluminium permanent-mould casting.

Technical Notes

There are gripping indentations on the rear

sides.

For keyways information (dim. t_1 and b_3) to DIN 6885.

Order No.	Type	d_1	d_2 tol. H7	d_3	l_1 ≈	l_2	b_3	t	Weight g
77200.W0103	Without Keyway	80	10	26	29	16	-	-	119
77200.W0104	Without Keyway	80	12	26	29	16	-	-	116
77200.W0105	Without Keyway	100	10	28	33	17	-	-	194
77200.W0106	Without Keyway	100	12	28	33	17	-	-	194
77200.W0110	Without Keyway	125	12	31	36	18	-	-	288
77200.W0111	Without Keyway	125	14	31	36	18	-	-	288
77200.W0120	Without Keyway	160	14	36	40	20	-	-	477
77200.W0121	Without Keyway	160	16	36	40	20	-	-	477
77200.W0130	Without Keyway	200	18	42	45	24	-	-	955
77200.W0131	Without Keyway	200	22	42	45	24	-	-	955
77200.W0140	Without Keyway	250	22	48	50	28	-	-	1685
77200.W0141	Without Keyway	250	26	48	50	28	-	-	1685
77200.W0150	Without Keyway	315	26	56	56	33	-	-	2710
77200.W0151	Without Keyway	315	28	56	56	33	-	-	2700
77200.W0160	Without Keyway	400	30	65	63	38	-	-	4720
77200.W0161	Without Keyway	400	32	65	63	38	-	-	4660
77200.W0303	With Keyway	80	10	26	29	16	3	11.4	120
77200.W0304	With Keyway	80	12	26	29	16	4	13.8	129
77200.W0305	With Keyway	100	10	28	33	17	3	11.4	190
77200.W0306	With Keyway	100	12	28	33	17	4	13.8	190
77200.W0310	With Keyway	125	12	31	36	18	4	13.8	250
77200.W0311	With Keyway	125	14	31	36	18	5	16.3	250
77200.W0320	With Keyway	160	14	36	40	20	5	16.3	491
77200.W0321	With Keyway	160	16	36	40	20	5	18.3	491
77200.W0330	With Keyway	200	18	42	45	24	6	20.8	933
77200.W0331	With Keyway	200	22	42	45	24	6	24.8	933
77200.W0340	With Keyway	250	22	48	50	28	6	24.8	1662
77200.W0341	With Keyway	250	26	48	50	28	8	29.3	1662
77200.W0350	With Keyway	315	26	56	56	33	8	29.3	2700
77200.W0351	With Keyway	315	28	56	56	33	8	31.3	2670
77200.W0360	With Keyway	400	30	65	63	38	8	33.3	4760
77200.W0361	With Keyway	400	32	65	63	38	10	35.3	4720



77400

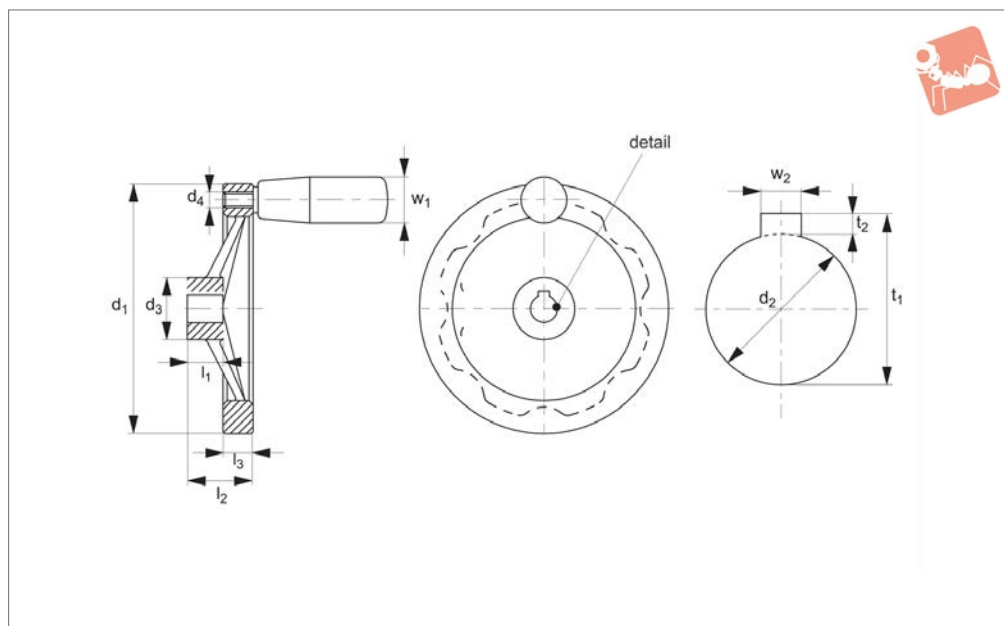

Material

Aluminium mould casting. Handle duroplast DF 31 black.

Hub machined; rim turned and mirror-finished on all sides, non-machined surfaces cleanly blasted.

For corresponding handle details see no. 75120 rotating handle.

Technical Notes

There are gripping indentations on the rear sides.

The non-machined, raw surfaces are blasted; together with the mirror-polished rim these handwheels are therefore showing a finish which in most cases does not require additional lacquering.

Temperature range up to 110°C. Also available in black plastic coated - on request.

For keyways information (dim. t_1 and b_3) to DIN 6885.

Order No.	Finish	Bore dia.	d_1	d_2 tol. H7 Small	d_2 tol. H7 Large	d_3	d_4	l_1	l_2 ~	l_3	w_1	Weight g
77400.W0008	W/o Keyway, W/o Handle	d2 Small	80	10	12	26	-	16	26	13.0	-	130
77400.W0009	W/o Keyway, W/o Handle	d2 Large	80	10	12	26	-	16	26	13.0	-	130
77400.W0010	W/o Keyway, W/o Handle	d2 Small	100	10	12	28	-	17	30	14.0	-	203
77400.W0011	W/o Keyway, W/o Handle	d2 Large	100	10	12	28	-	17	30	14.0	-	203
77400.W0012	W/o Keyway, W/o Handle	d2 Small	125	12	14	31	-	18	33	15.0	-	307
77400.W0013	W/o Keyway, W/o Handle	d2 Large	125	12	14	31	-	18	33	15.0	-	307
77400.W0014	W/o Keyway, W/o Handle	d2 Small	140	14	16	36	-	19	36	16.5	-	430
77400.W0015	W/o Keyway, W/o Handle	d2 Large	140	14	16	36	-	19	36	16.5	-	430
77400.W0016	W/o Keyway, W/o Handle	d2 Small	160	14	16	36	-	20	39	18.0	-	540
77400.W0017	W/o Keyway, W/o Handle	d2 Large	160	14	16	36	-	20	39	18.0	-	540
77400.W0020	W/o Keyway, W/o Handle	d2 Small	200	18	20	42	-	24	45	20.5	-	849
77400.W0021	W/o Keyway, W/o Handle	d2 Large	200	18	20	42	-	24	45	20.5	-	849
77400.W0025	W/o Keyway, W/o Handle	d2 Small	250	22	26	48	-	28	51	23.5	-	1495
77400.W0026	W/o Keyway, W/o Handle	d2 Large	250	22	26	48	-	28	51	23.5	-	1495
77400.W0108	With Keyway, W/o Handle	d2 Small	80	10	12	26	-	16	26	13.0	-	139
77400.W0109	With Keyway, W/o Handle	d2 Large	80	10	12	26	-	16	26	13.0	-	139
77400.W0110	With Keyway, W/o Handle	d2 Small	100	10	12	28	-	17	30	14.0	-	190
77400.W0111	With Keyway, W/o Handle	d2 Large	100	10	12	28	-	17	30	14.0	-	190
77400.W0112	With Keyway, W/o Handle	d2 Small	125	12	14	31	-	18	33	15.0	-	291
77400.W0113	With Keyway, W/o Handle	d2 Large	125	12	14	31	-	18	33	15.0	-	291
77400.W0114	With Keyway, W/o Handle	d2 Small	140	14	16	36	-	19	36	16.5	-	413
77400.W0115	With Keyway, W/o Handle	d2 Large	140	14	16	36	-	19	36	16.5	-	413
77400.W0116	With Keyway, W/o Handle	d2 Small	160	14	16	36	-	20	39	18.0	-	529
77400.W0117	With Keyway, W/o Handle	d2 Large	160	14	16	36	-	20	39	18.0	-	529
77400.W0120	With Keyway, W/o Handle	d2 Small	200	18	20	42	-	24	45	20.5	-	880
77400.W0121	With Keyway, W/o Handle	d2 Large	200	18	20	42	-	24	45	20.5	-	880
77400.W0125	With Keyway, W/o Handle	d2 Small	250	22	26	48	-	28	51	23.0	-	1515
77400.W0126	With Keyway, W/o Handle	d2 Large	250	22	26	48	-	28	51	23.0	-	1515
77400.W0508	W/o Keyway, With Handle	d2 Small	80	10	12	26	M 6	16	26	13.0	18	160

Disc Type Handwheels



Handwheels

Order No.	Finish	Bore dia.	d ₁	d ₂ tol. H7 Small	d ₂ tol. H7 Large	d ₃	d ₄	l ₁	l ₂ z	l ₃	w ₁	Weight g
77400.W0509	W/o Keyway, With Handle	d2 Large	80	10	12	26	M 6	16	26	13.0	18	160
77400.W0510	W/o Keyway, With Handle	d2 Small	100	10	12	28	M 6	17	30	14.0	21	255
77400.W0511	W/o Keyway, With Handle	d2 Large	100	10	12	28	M 6	17	30	14.0	21	255
77400.W0512	W/o Keyway, With Handle	d2 Small	125	12	14	31	M 8	18	33	15.0	23	390
77400.W0513	W/o Keyway, With Handle	d2 Large	125	12	14	31	M 8	18	33	15.0	23	390
77400.W0514	W/o Keyway, With Handle	d2 Small	140	14	16	36	M 8	19	36	16.5	23	510
77400.W0515	W/o Keyway, With Handle	d2 Large	140	14	16	36	M 8	19	36	16.5	23	510
77400.W0516	W/o Keyway, With Handle	d2 Small	160	14	16	36	M10	20	39	18.0	26	675
77400.W0517	W/o Keyway, With Handle	d2 Large	160	14	16	36	M10	20	39	18.0	26	675
77400.W0520	W/o Keyway, With Handle	d2 Small	200	18	20	42	M10	24	45	20.5	26	995
77400.W0521	W/o Keyway, With Handle	d2 Large	200	18	20	42	M10	24	45	20.5	26	995
77400.W0525	W/o Keyway, With Handle	d2 Small	250	22	26	48	M10	28	51	23.0	28	1625
77400.W0526	W/o Keyway, With Handle	d2 Large	250	22	26	48	M10	28	51	23.0	28	1625
77400.W0608	With Keyway, With Handle	d2 Small	80	10	12	26	M 6	16	26	13.0	18	160
77400.W0609	With Keyway, With Handle	d2 Large	80	10	12	26	M 6	16	26	13.0	18	160
77400.W0610	With Keyway, With Handle	d2 Small	100	10	12	28	M 6	17	30	14.0	21	255
77400.W0611	With Keyway, With Handle	d2 Large	100	10	12	28	M 6	17	30	14.0	21	255
77400.W0612	With Keyway, With Handle	d2 Small	125	12	14	31	M 8	18	33	15.0	23	390
77400.W0613	With Keyway, With Handle	d2 Large	125	12	14	31	M 8	18	33	15.0	23	390
77400.W0614	With Keyway, With Handle	d2 Small	140	14	16	36	M 8	19	36	16.5	23	510
77400.W0615	With Keyway, With Handle	d2 Large	140	14	16	36	M 8	19	36	16.5	23	510
77400.W0616	With Keyway, With Handle	d2 Small	160	14	16	36	M10	20	39	18.0	26	675
77400.W0617	With Keyway, With Handle	d2 Large	160	14	16	36	M10	20	39	18.0	26	675
77400.W0620	With Keyway, With Handle	d2 Small	200	18	20	42	M10	24	45	20.5	26	995
77400.W0621	With Keyway, With Handle	d2 Large	200	18	20	42	M10	24	45	20.5	26	995
77400.W0625	With Keyway, With Handle	d2 Small	250	22	26	48	M10	28	51	23.0	28	1625
77400.W0626	With Keyway, With Handle	d2 Large	250	22	26	48	M10	28	51	23.0	28	1625

HANDWHEELS

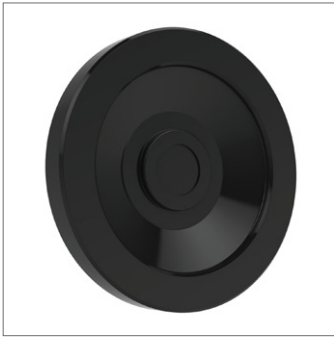

77600

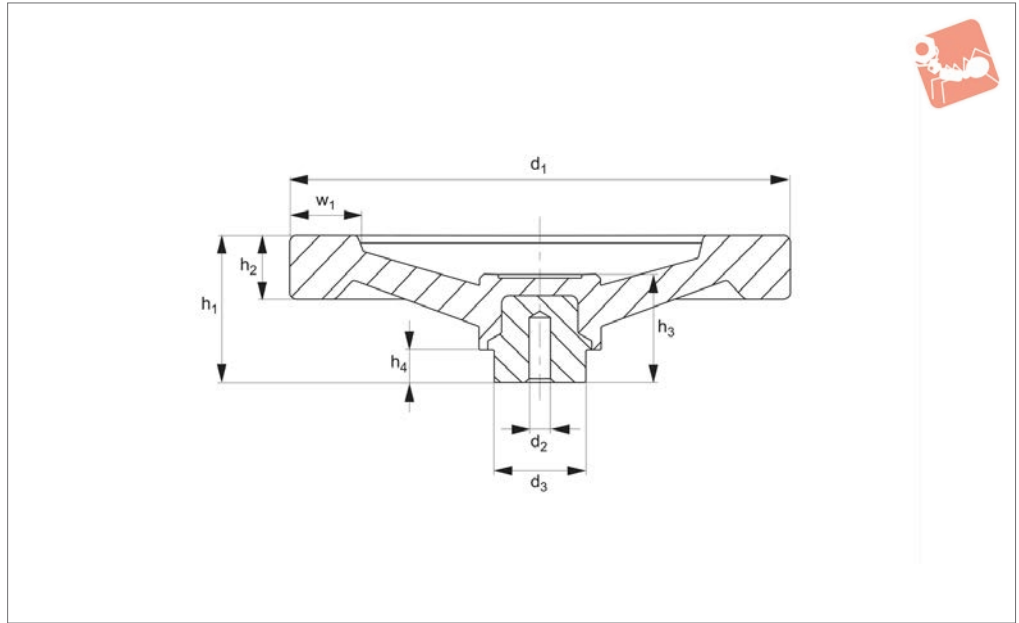

HANDWHEELS

Material

Black, duroplast, with zinc plated steel hub.

Technical Notes

The pilot hole allows various sizes of holes, keyways etc. to be machined into the hub.

Order No.	d ₁	d ₂	d ₃	h ₁	h ₂	h ₃	h ₄	w ₁	Weight g
77600.W0100	100	4	24	35	14	30	11	16	200
77600.W0125	125	6	32	44	16	36	13	18	338
77600.W0150	150	6	32	48	18	38	13	20	458
77600.W0200	200	6	40	58	21	45	16	24	853
77600.W0250	250	8	48	66	22	50	17	30	1464
77600.W0300	300	8	58	76	24	57	18	35	2473

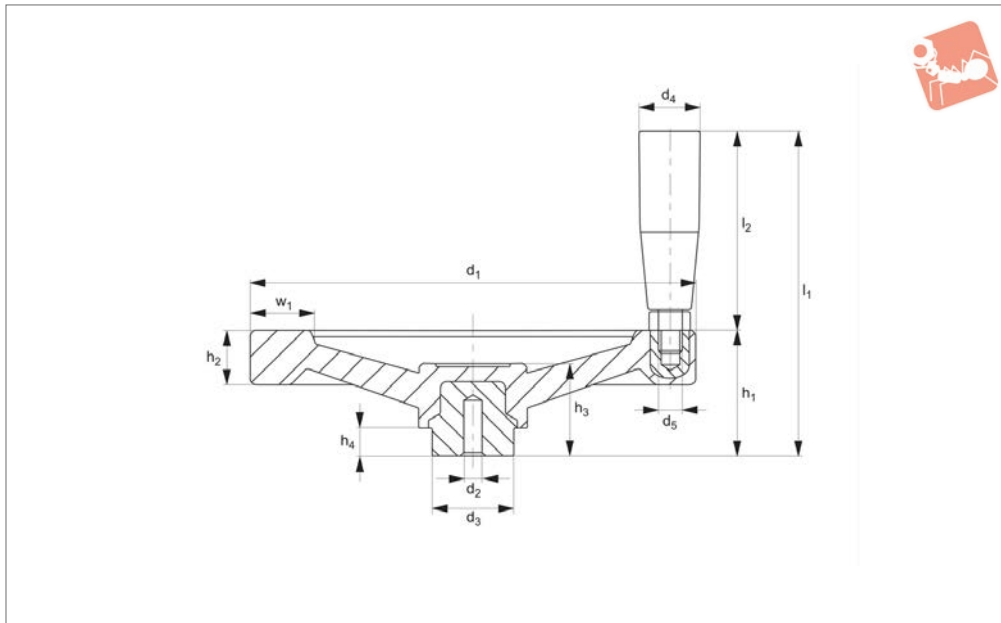

77620

HANDWHEELS

Material

Black, duroplast plastic with zinc plated steel hub.

Technical Notes

The pilot hole allows various sizes of holes, keyways etc. to be machined into the hub.

Order No.	d ₁	d ₂	d ₃	d ₄	d ₅	h ₁	h ₂	h ₃	h ₄	l ₁	l ₂	w ₁	Weight g
77620.W0100	100	4	24	21	M 8	35	14	30	21	85	50	16	231
77620.W0125	125	6	32	23	M 8	45	16	36	13	99	55	18	391
77620.W0150	150	6	32	25	M10	48	18	38	13	113	65	20	541
77620.W0200	200	6	40	28	M10	58	21	45	16	143	85	24	969
77620.W0250	250	8	48	28	M10	66	22	50	17	151	85	30	1589
77620.W0300	300	8	58	28	M10	76	24	57	18	161	85	35	2700



77640

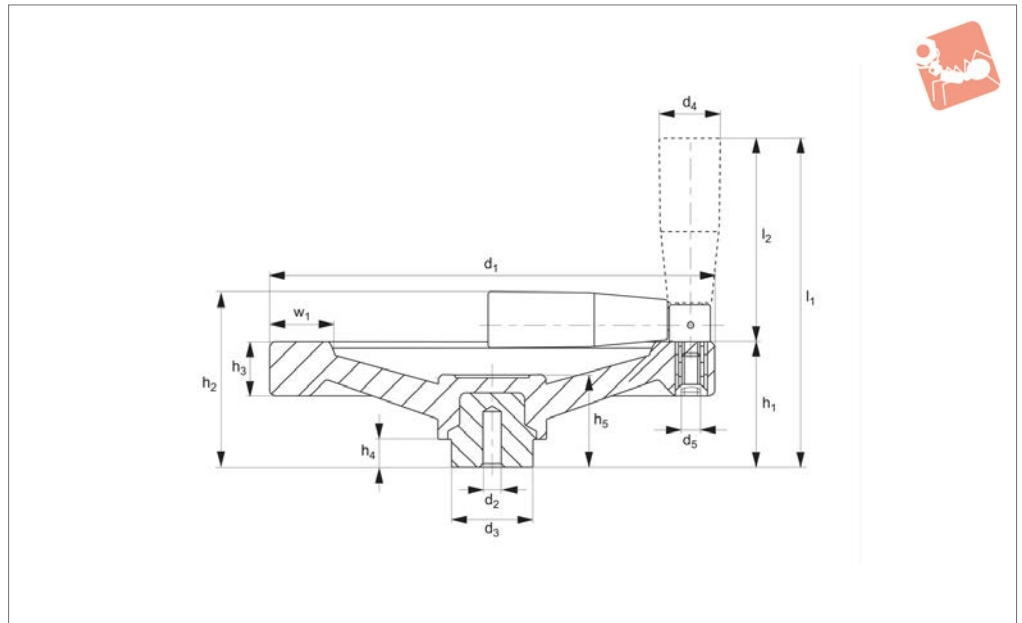

Material

Duroplast, black. Zinc plated steel hub.

Technical Notes

The pilot hole allows various sizes of holes, keyways etc. to be machined into the hub.

Order No.	d ₁	d ₂	d ₃	d ₄	d ₅	h ₁	h ₂	h ₃	h ₄	h ₅	l ₁	l ₂	w ₁	Weight g
77640.W0100	100	4	24	21	M 5	35	54	14	11	30	102	50	16	251
77640.W0125	125	6	32	23	M 5	44	64	16	13	36	116	55	18	419
77640.W0150	150	6	32	25	M 6	48	69	18	13	38	130	65	20	539
77640.W0200	200	6	40	28	M 6	58	82	21	16	45	163	85	24	992
77640.W0250	250	8	48	28	M 6	66	90	22	17	50	171	85	30	1612
77640.W0300	300	8	58	28	M 6	76	100	24	18	57	181	85	35	2723



Solid Disc Handwheels with double fixed handle



Handwheels

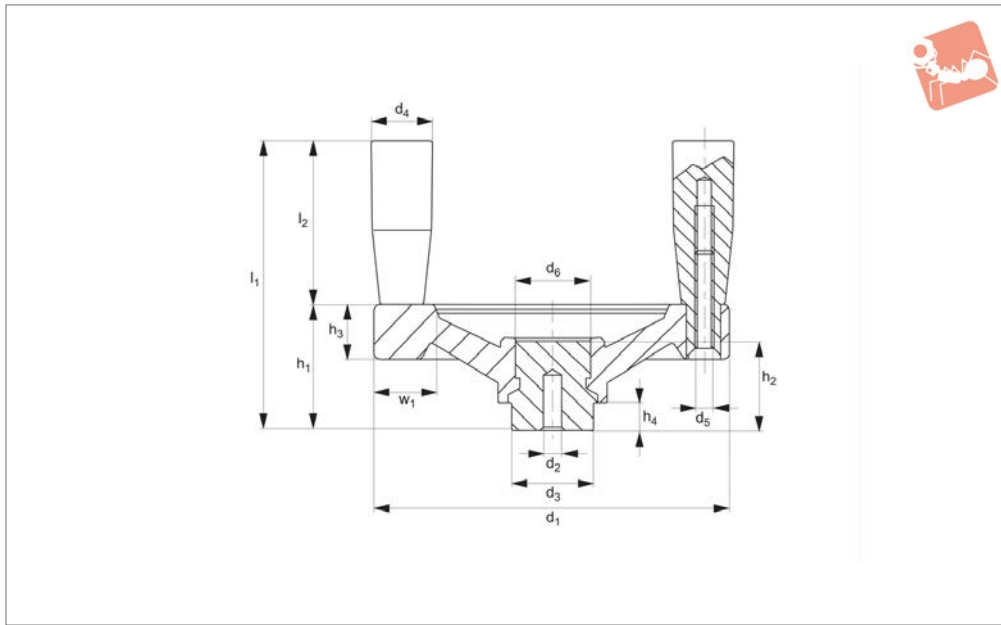

77680

HANDWHEELS

Material

Duroplast, black. Zinc plated steel hub.

Technical Notes

The pilot hole allows various sizes of holes, keyways etc. to be machined into the hub.

Order No.	d ₁	d ₂	d ₃	d ₄	d ₅	d ₆	h ₁	h ₂	h ₃	h ₄	l ₁	l ₂	w ₁	Weight g
77680.W0065	65	4	20	10	M 5	15	28	24	13	13	55	27	13	111
77680.W0080	80	4	20	10	M 6	16	31	27	14	17	71	40	15	155
77680.W0100	100	4	24	11	M 6	20	35	29	14	21	85	50	16	265



HANDWHEELS



77720

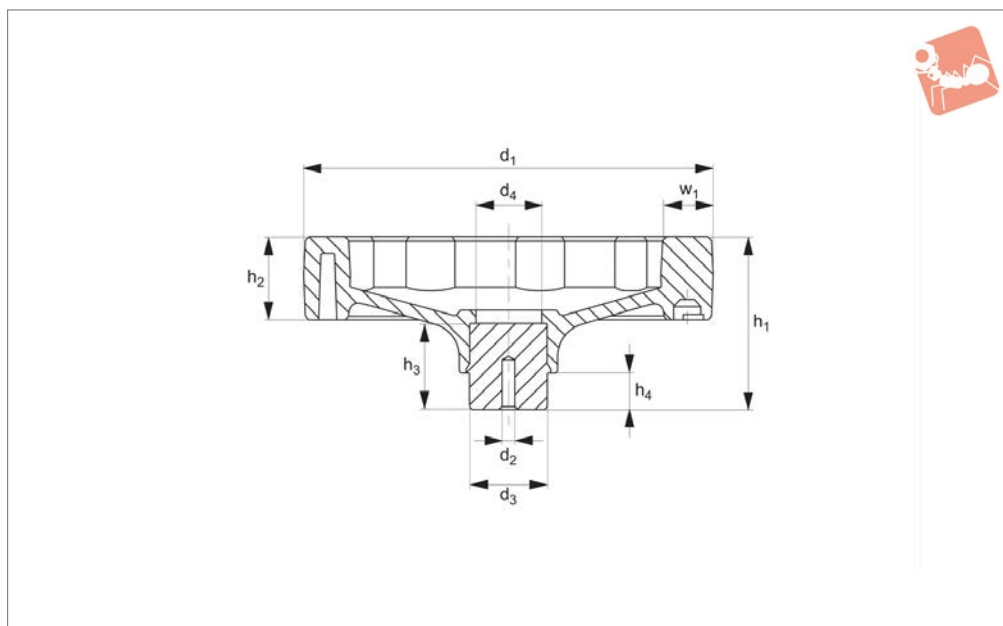

Material

Thermoplastic, black, matt. Zinc plated steel hub.

Technical Notes

The pilot hole allows various sizes of holes, keyways etc. to be machined into the hub.

Order No.	d ₁	d ₂	d ₃	d ₄	h ₁	h ₂	h ₃	h ₄	w ₁	Weight g
77720.W0100	100	4	24	18	46	20	24	12	15	174
77720.W0125	125	6	24	20	51	24	28	12	17	248
77720.W0160	160	6	32	30	61	28	31	15	20	460
77720.W0200	200	6	40	35	74	32	40	15	24	863



Solid Disc Handwheels with rotating grip

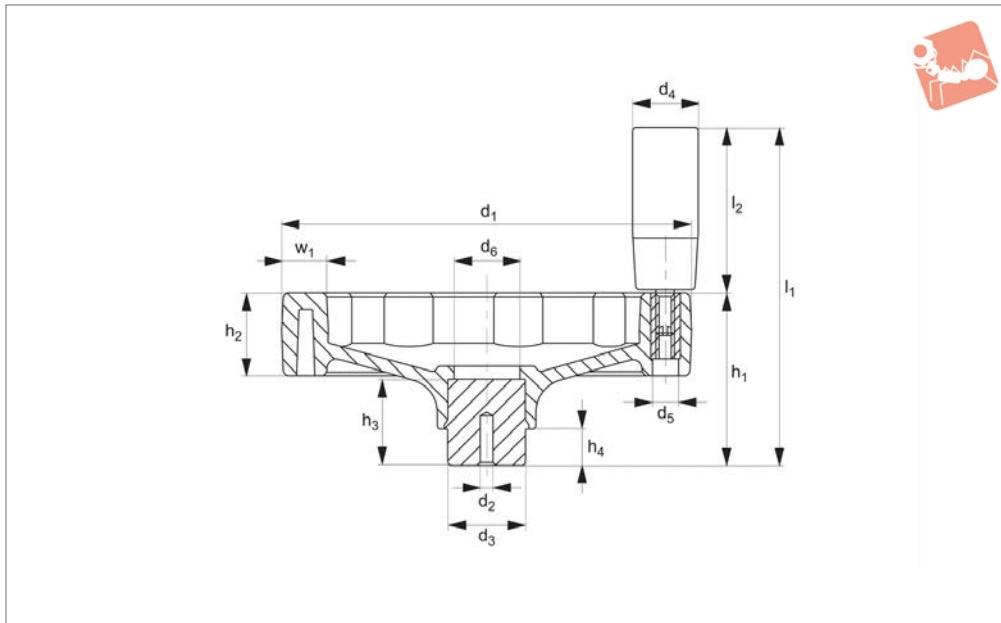

77740

HANDWHEELS

Material

Thermoplastic, black, matt. Zinc plated steel hub.

Technical Notes

The pilot hole allows various sizes of holes, keyways etc. to be machined into the hub.

Order No.	d ₁	d ₂	d ₃	d ₄	d ₅	d ₆	h ₁	h ₂	h ₃	h ₄	l ₁	l ₂	w ₁	Weight g
77740.W0100	100	4	24	12	M_6	18	46	20	24	21	96	50	15	196
77740.W0125	125	6	24	12	M_6	20	51	24	28	21	101	50	17	276
77740.W0160	160	6	32	15	M_8	30	61	28	31	23	131	70	20	504
77740.W0200	200	6	40	15	M10	35	74	32	40	26	164	90	24	950



77760

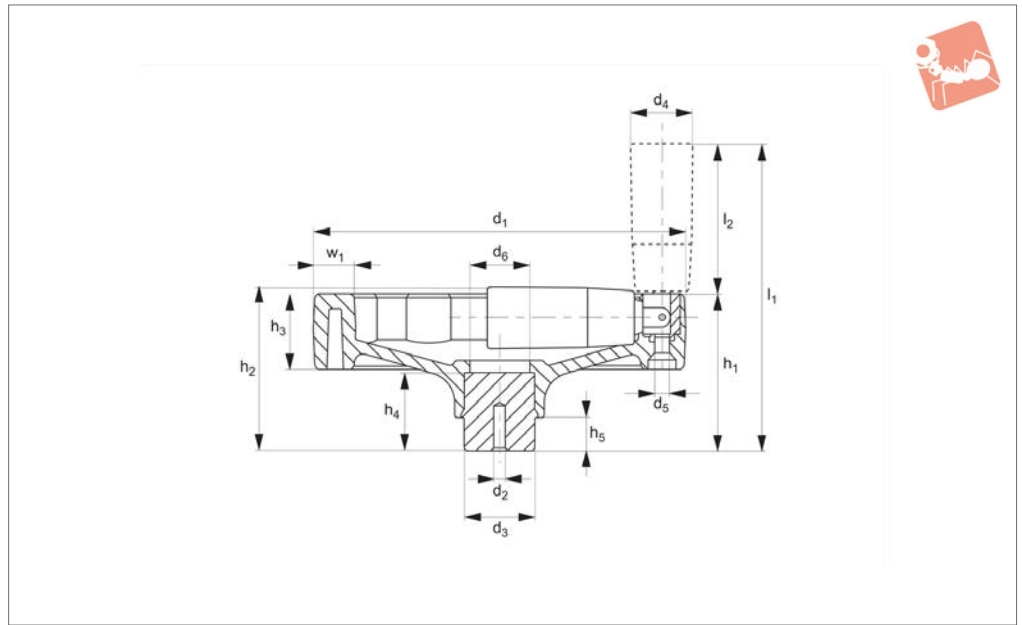

Material

Thermoplastic, black, matt. Zinc plated steel hub.

Technical Notes

The pilot hole allows various sizes of holes, keyways etc. to be machined into the hub.

Order No.	d ₁	d ₂	d ₃	d ₄	d ₅	d ₆	h ₁	h ₂	h ₃	h ₄	h ₅	l ₁	l ₂	w ₁	Weight g
77760.W0100	100	4	24	21	M_4	18	46	50	20	24	12	98	52	15	213
77760.W0125	125	6	24	21	M_4	20	51	54	24	28	12	103	52	17	284
77760.W0160	160	6	32	23	M_5	30	61	65	28	31	15	133	72	20	507
77760.W0200	200	6	40	26	M_6	35	74	79	32	40	15	166	92	24	950

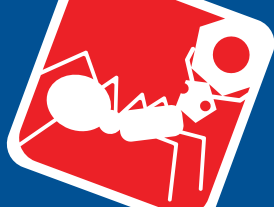

Cranked Handles

straight - DIN 469

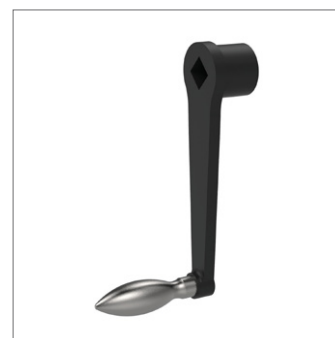
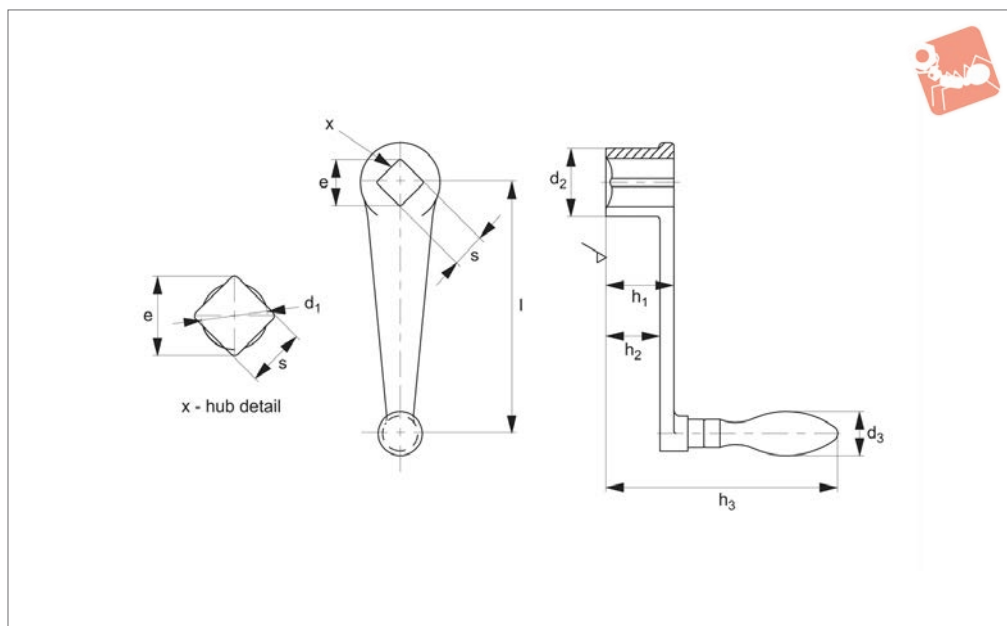

75200

CRANKED & REVOLVING HANDLES

Material

Size 63 - malleable cast iron.

Size 80-250 - nodular cast iron.

Deburred, sand blasted and black plastic

coated.

Handle body: cast iron (GTW), plastic coated, black.

For corresponding handle details see

no.75060 (non-removable).

Hub-machined, with square bore details to DIN 79.

Order No.	Finish	Size l	s tol. H11	e min.	d ₁	d ₂	h ₁	h ₂ ≈	h ₃	Corresp. handle dia. d ₃	Weight g
75200.W0006	Fixed Handle	63	10	13.1	10.5	20	20	15	74	16	109
75200.W0008	Fixed Handle	80	10	13.1	10.5	24	24	18	94	18	183
75200.W0010	Fixed Handle	100	12	16.1	12.6	28	28	21	98	20	278
75200.W0012	Fixed Handle	125	14	18.1	14.7	34	34	26	120	22	444
75200.W0016	Fixed Handle	160	17	22.2	17.9	38	38	29	122	25	649
75200.W0020	Fixed Handle	200	19	25.2	20.0	44	44	34	154	28	962
75200.W0025	Fixed Handle	250	22	28.2	23.1	48	48	36	157	32	1360
75200.W0108	Fixed Handle	80	12	16.1	12.6	24	24	18	94	18	186
75200.W0110	Fixed Handle	100	14	18.1	14.7	28	28	21	98	20	259
75200.W0112	Fixed Handle	125	17	22.2	17.9	34	34	26	120	22	433
75200.W0116	Fixed Handle	160	19	25.2	20.0	38	38	29	122	25	633
75200.W0120	Fixed Handle	200	22	28.2	23.1	44	44	34	154	28	983
75200.W0125	Fixed Handle	250	24	32.2	25.3	48	48	36	157	32	1351
75200.W0506	Rotating Handle	63	10	13.1	10.5	20	20	15	79	16	118
75200.W0508	Rotating Handle	80	10	13.1	10.5	24	24	18	97	18	194
75200.W0510	Rotating Handle	100	12	16.1	12.6	28	28	21	100	20	272
75200.W0512	Rotating Handle	125	14	18.1	14.7	34	34	26	122	22	468
75200.W0516	Rotating Handle	160	17	22.2	17.9	38	38	29	126	25	667
75200.W0520	Rotating Handle	200	19	25.2	20.0	44	44	34	160	28	1054
75200.W0525	Rotating Handle	250	22	28.2	23.1	48	48	36	162	32	1441
75200.W0608	Rotating Handle	80	12	16.1	12.6	24	24	18	97	18	197
75200.W0610	Rotating Handle	100	14	18.1	14.7	28	28	21	100	20	280
75200.W0612	Rotating Handle	125	17	22.2	17.9	34	34	26	122	22	433
75200.W0616	Rotating Handle	160	19	25.2	20.0	38	38	29	126	25	651
75200.W0620	Rotating Handle	200	22	28.2	23.1	44	44	34	160	28	992
75200.W0625	Rotating Handle	250	24	32.2	25.3	48	48	36	162	32	1409



75202

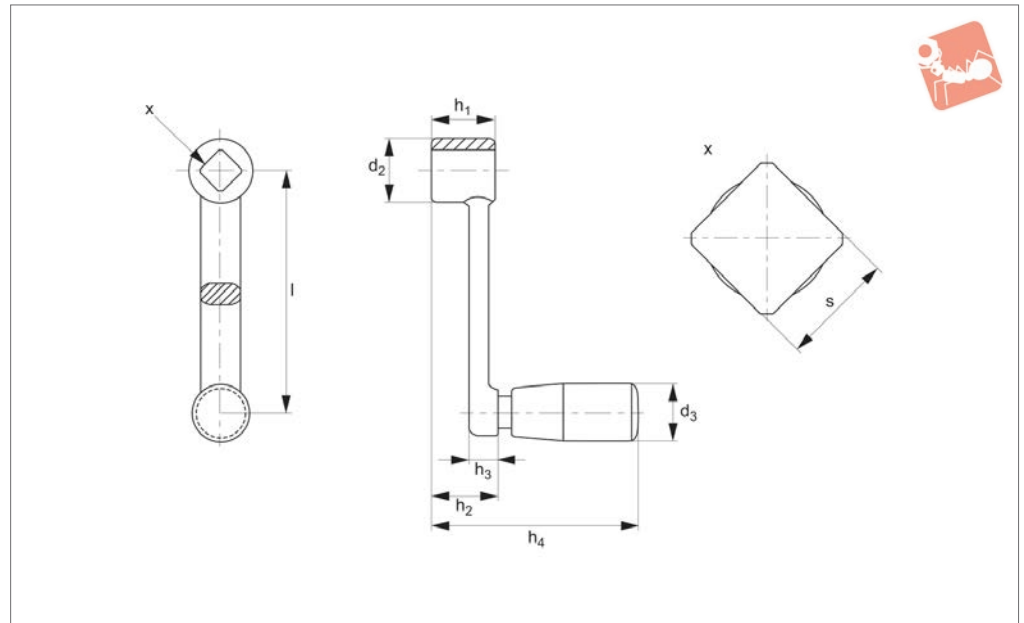

Material

Handle body: stainless steel 1.4308.

Cylindrical handle: Thermoset PF 31, black.

Axe part: stainless steel 1.4301.

Technical Notes

Flat side of the hub is machined.

Order No.	l	s tol. H11	d ₂	d ₃ cylinder-grip 75120	h ₁	h ₂ ≈	h ₃	h ₄ ≈	Weight g
75202.W0520	80	10	22	18	22	15.4	6.6	57.9	124
75202.W0530	100	12	22	21	26	17.7	8.3	70.2	187
75202.W0540	125	14	28	23	28	18.8	9.2	86.3	320
75202.W0550	160	17	32	23	32	22.6	9.4	90.1	370

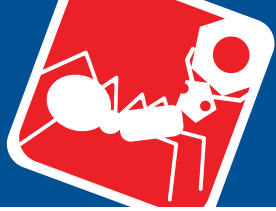

Cranked Handles

folding handle

Cranked & Revolving

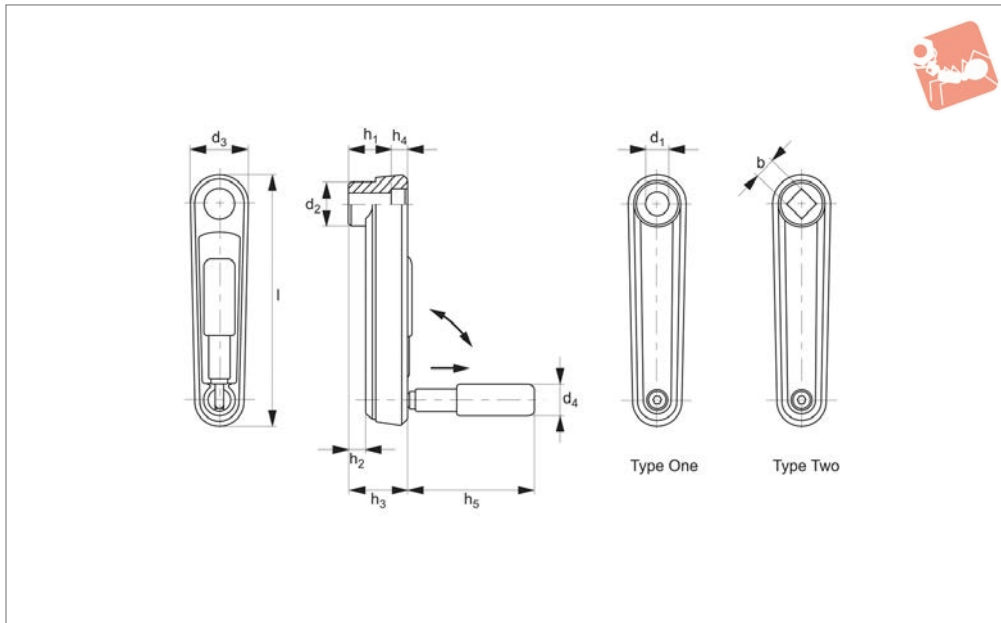

75210

CRANKED & REVOLVING HANDLES

Material

Axle: Steel, blackened.
 Cover: plastic, grey.
 Body: Aluminium, plastic coated, structural matt.

Silver - similar RAL 9006
 Black - similar RAL9005
 Handle: Plastic, black matt.

Technical Notes

Operating: Handle is locked in position.
 To store: Pull handle along axis and lift into locked position.

Order No.	Type, colour	b tol. H11	d ₁ tol. H7	d ₂	d ₃	d ₄ dia.	h ₁	h ₂	h ₃	h ₄	h ₅	Weight g
75210.W0005	One, silver	-	10	23.0	30	16	19.5	4.0	25.5	4.3	43.0	131
75210.W0010	One, silver	-	12	26.7	35	18	23.5	5.5	29.5	4.2	57.5	180
75210.W0015	One, silver	-	14	28.0	37	24	30.5	10.5	36.5	4.2	76.5	305
75210.W0105	One, black	-	10	23.0	30	16	19.5	4.0	25.5	4.3	43.0	131
75210.W0110	One, black	-	12	26.7	35	18	23.5	5.5	29.5	4.2	57.5	180
75210.W0115	One, black	-	14	28.0	37	24	30.5	10.5	36.5	4.2	76.5	305
75210.W0205	Two, silver	10	-	23.0	30	16	19.5	4.0	25.5	4.3	43.0	131
75210.W0210	Two, silver	12	-	26.7	35	18	23.5	5.5	29.5	4.2	57.5	180
75210.W0215	Two, silver	14	-	28.0	37	24	30.5	10.5	36.5	4.2	76.5	280
75210.W0305	Two, black	10	-	23.0	30	16	19.5	4.0	25.5	4.3	43.0	131
75210.W0310	Two, black	12	-	26.7	35	18	23.5	5.5	29.5	4.2	57.5	180
75210.W0315	Two, black	14	-	28.0	37	24	30.5	10.5	36.5	4.2	76.5	280



75212

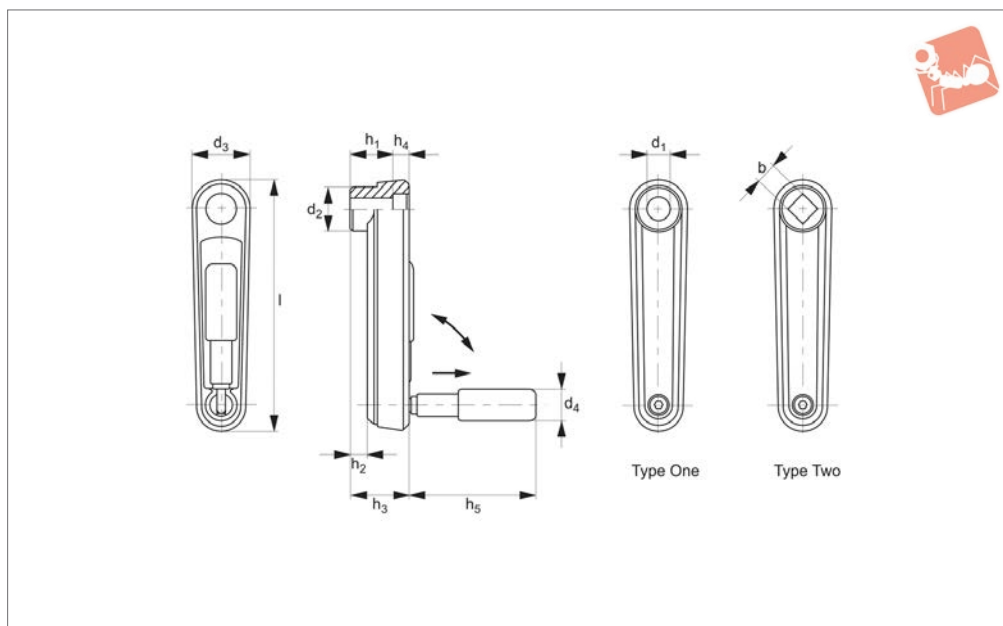

Material

Axle: Stainless steel 1.4305.

Cover: plastic, grey.

Body: Aluminium, plastic coated, structural matt.

Silver - similar RAL 9006

Black - similar RAL9005

Handle: Plastic, black matt.

Technical Notes

Operating: Handle is locked in position.

To store: Pull handle along axis and lift into locked position.

Order No.	Type, colour	b tol. H11	d_1 tol. H7	d_2	d_3	d_4 dia.	h_1	h_2	h_3	h_4	h_5	Weight g
75212.W0405	One, silver	-	10	23.0	30	16	19.5	4.0	25.5	4.3	43.0	118
75212.W0410	One, silver	-	12	26.7	35	18	23.5	5.5	29.5	4.2	57.5	197
75212.W0415	One, silver	-	14	28.0	37	24	30.5	10.5	36.5	4.2	76.5	283
75212.W0505	One, black	-	10	23.0	30	16	19.5	4.0	25.5	4.3	43.0	118
75212.W0510	One, black	-	12	26.7	35	18	23.5	5.5	29.5	4.2	57.5	197
75212.W0515	One, black	-	14	28.0	37	24	30.5	10.5	36.5	4.2	76.5	283
75212.W0605	Two, silver	10	-	23.0	30	16	19.5	4.0	25.5	4.3	43.0	118
75212.W0606	Two, silver	12	-	26.7	35	18	23.5	5.5	29.5	4.2	57.5	197
75212.W0607	Two, silver	14	-	28.0	37	24	30.5	10.5	36.5	4.2	76.5	283
75212.W0705	Two, black	10	-	23.0	30	16	19.5	4.0	25.5	4.3	43.0	118
75212.W0710	Two, black	12	-	26.7	35	18	23.5	5.5	29.5	4.2	57.5	197
75212.W0715	Two, black	14	-	28.0	37	24	30.5	10.5	36.5	4.2	76.5	283

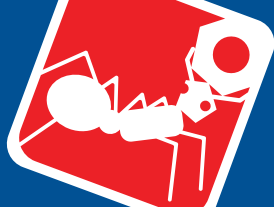

Cranked Handles

offset - DIN 468

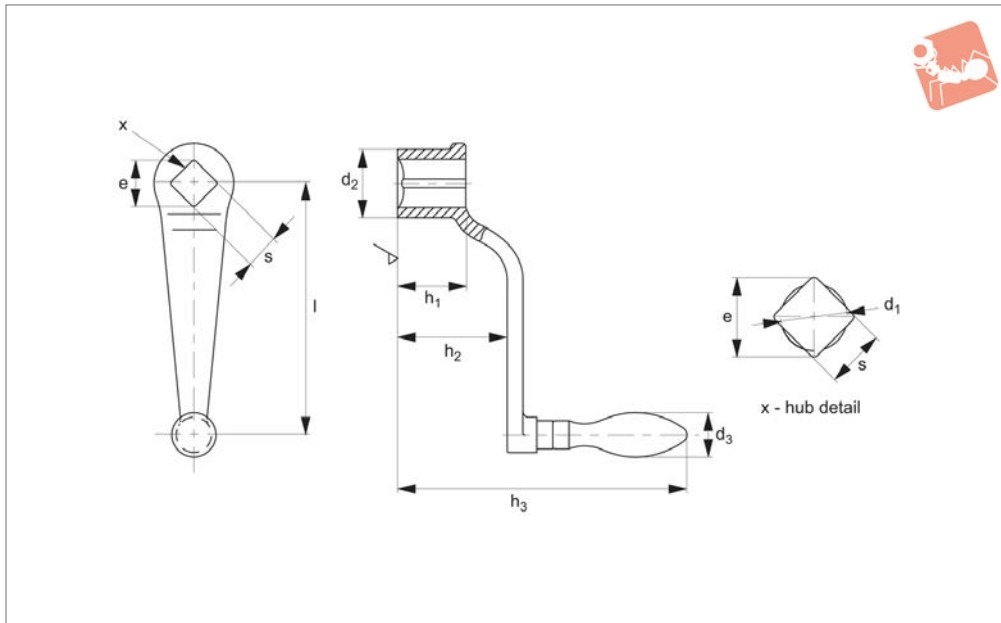
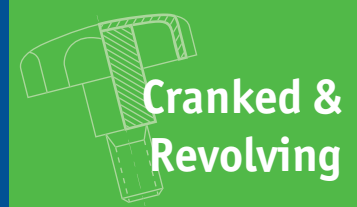

75220

CRANKED & REVOLVING HANDLES

Material

Size 63 - malleable cast iron.

Size 80-250 - nodular cast iron.

Deburred, sand blasted and black plastic

coated.

Handle body: cast iron (GTW), plastic coated, black.

For corresponding handle details see

no.75060 (non-removable).

Hub-machined, with square bore details to DIN 79.

Order No.	Finish	Size l	s tol. H11	e min.	d ₁	d ₂	h ₁	h ₂ ≈	h ₃	Corresp. handle dia. d ₃	Weight g
75220.W0006	Fixed Handle	63	10	13.1	10.5	20	20	32	92	16	112
75220.W0008	Fixed Handle	80	10	13.1	10.5	24	24	38	114	18	187
75220.W0010	Fixed Handle	100	12	16.1	12.6	28	28	48	124	20	288
75220.W0012	Fixed Handle	125	14	18.1	14.7	34	34	55	148	22	460
75220.W0016	Fixed Handle	160	17	22.2	17.9	38	38	65	158	25	661
75220.W0020	Fixed Handle	200	19	25.2	20.0	44	44	78	197	28	1020
75220.W0025	Fixed Handle	250	22	28.2	23.1	48	48	90	209	32	1438
75220.W0108	Fixed Handle	80	12	16.1	12.6	24	24	38	114	18	183
75220.W0110	Fixed Handle	100	14	18.1	14.7	28	28	48	124	20	292
75220.W0112	Fixed Handle	125	17	22.2	17.9	34	34	55	148	22	439
75220.W0116	Fixed Handle	160	19	25.2	20.0	38	38	65	158	25	627
75220.W0120	Fixed Handle	200	22	28.2	23.1	44	44	78	197	28	1004
75220.W0125	Fixed Handle	250	24	32.2	25.3	48	48	90	209	32	1415
75220.W0130	Fixed Handle	315	24	32.2	25.3	54	54	105	192	36	2200
75220.W0132	Fixed Handle	315	27	36.2	28.4	54	54	105	192	36	2100
75220.W0506	Rotating Handle	63	10	13.1	10.5	20	20	32	96	16	118
75220.W0508	Rotating Handle	80	10	13.1	10.5	24	24	38	116	18	201
75220.W0510	Rotating Handle	100	12	16.1	12.6	28	28	48	126	20	310
75220.W0512	Rotating Handle	125	14	18.1	14.7	34	34	55	150	22	464
75220.W0516	Rotating Handle	160	17	22.2	17.9	38	38	65	160	25	674
75220.W0520	Rotating Handle	200	19	25.2	20.0	44	44	78	202	28	1083
75220.W0525	Rotating Handle	250	22	28.2	23.1	48	48	90	214	32	1497
75220.W0608	Rotating Handle	80	12	16.1	12.6	24	24	38	116	18	200
75220.W0610	Rotating Handle	100	14	18.1	14.7	28	28	48	126	20	291
75220.W0612	Rotating Handle	125	17	22.2	17.9	34	34	55	150	22	455
75220.W0616	Rotating Handle	160	19	25.2	20.0	38	38	65	160	25	664
75220.W0620	Rotating Handle	200	22	28.2	23.1	44	44	78	202	28	1034
75220.W0625	Rotating Handle	250	24	32.2	25.3	48	48	90	214	32	1478
75220.W0630	Rotating Handle	315	24	32.2	25.3	54	54	105	186	36	2220
75220.W0632	Rotating	315	27	36.2	28.4	54	54	105	186	36	2200



75240

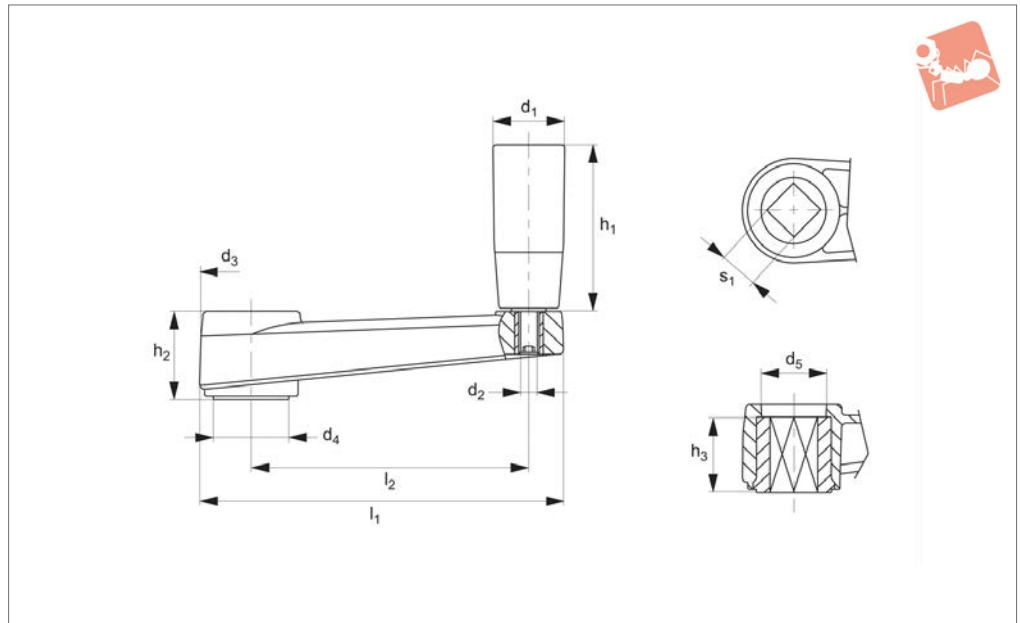

Material

Thermoplastic, black, matt. Glass fibre reinforced. Revolving handle.
Revolving grip: duroplast, black.

Handle arm: thermoplastic, black matte.

Technical Notes

Special inch and metric bars, keyways, set

screw holes etc. available on request.

Corresponding machine handles are part number 75120.

Order No.	d ₁	d ₂	d ₃	d ₄	d ₅	h ₁	h ₂	h ₃	l ₁	l ₂	s ₁	Weight g
75240.W0065	17	M 6	27	18	16	40	23	20	87	65	8x8	77
75240.W0080	21	M 6	30	22	19	50	26	22	105	80	10x10	120
75240.W0100	25	M 8	34	24	22	65	30	27	128	100	12x12	293
75240.W0130	28	M 8	40	28	25	85	35	30	162	130	14x14	236
75240.W0160	28	M10	45	34	28	85	40	34	196	160	17x17	369

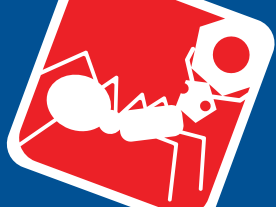

Cranked Handles with rotating grip



Cranked & Revolving

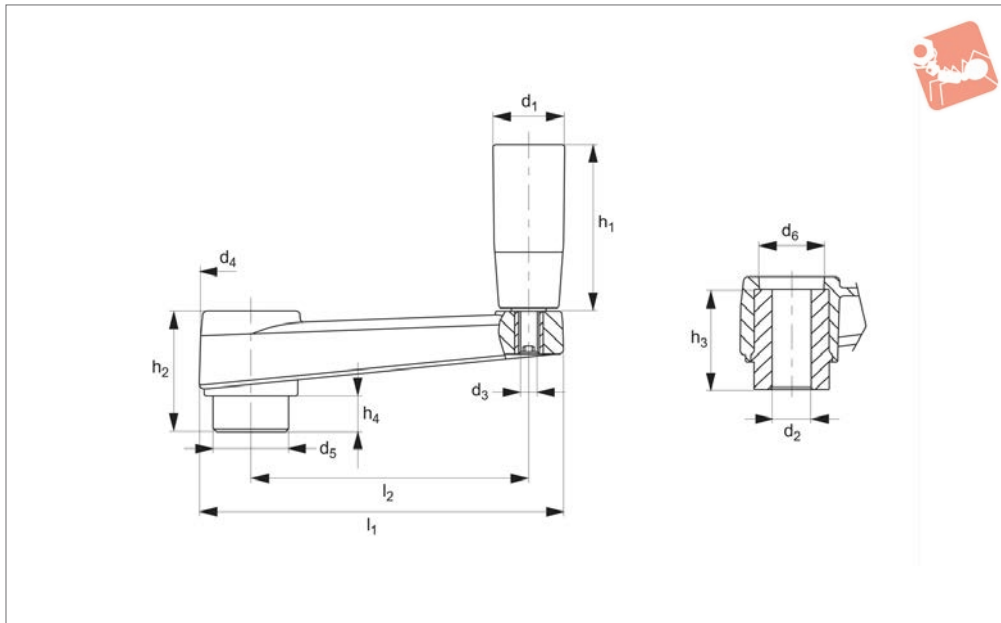

75260

CRANKED & REVOLVING HANDLES

Material

Thermoplast, black, matt. Glass fibre reinforced.

Revolving grip: duroplast, black.

Handle arm: thermoplast, black matte.

Technical Notes

Special inch and metric bars, keyways, set

screw holes etc. available on request.

Circular bore.

Order No.	d ₁	d ₂	d ₃	d ₄	d ₅	d ₆	h ₁	h ₂	h ₃	h ₄	l ₁	l ₂	Weight g
75260.W0065	10	8	M 6	27	18	16	40	33	30	17	87	65	92
75260.W0080	10	10	M 6	30	22	19	50	36	32	21	105	80	144
75260.W0100	10	12	M 8	34	24	22	65	40	37	25	128	100	232
75260.W0130	14	14	M 8	40	28	25	85	49	44	28	162	130	327
75260.W0160	15	16	M10	45	34	28	85	55	49	28	196	160	510



75280

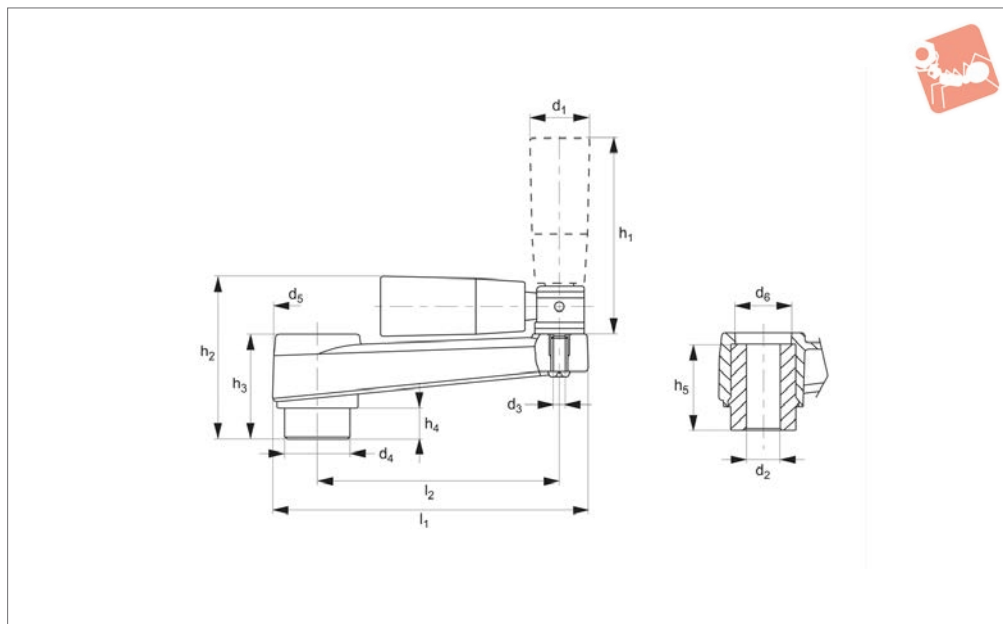

Material

Thermoplastic, black, matt. Glass fibre reinforced. Fold-away revolving handle. Revolving grip: duroplast, black.

Handle arm: thermoplastic, black matte.

screw holes etc available on request. Circular bore.

Technical Notes

Special inch and metric bars, keyways, set

Order No.	d ₁	d ₂	d ₃	d ₄	d ₅	d ₆	h ₁	h ₂	h ₃	h ₄	h ₅	l ₁	l ₂	Weight g
75280.W0080	10	10	M 5	22	30	19	50	55	36	21	32	105	80	166
75280.W0100	10	12	M 6	24	34	22	70	65	40	23	37	128	100	241
75280.W0130	14	14	M 6	28	40	25	70	76	49	23	44	162	130	335
75280.W0160	15	16	M 6	34	45	28	90	87	55	26	49	196	160	529

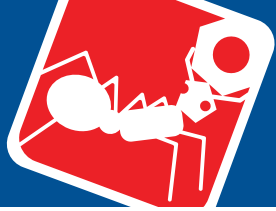

Cranked Handles with rotating grip

Cranked & Revolving

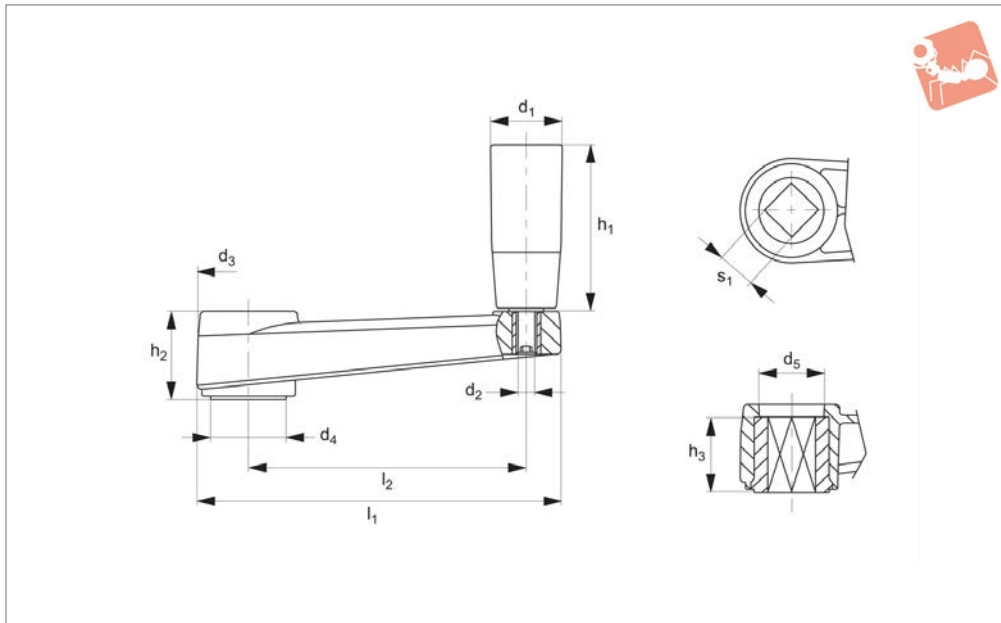

75340

CRANKED & REVOLVING HANDLES

Material

Thermoplastic, black, matt. Glass fibre reinforced. Revolving handle.
Revolving grip and handle arm: thermoplastic, black matte.

stic, black matte.

screw holes etc. available upon request.

Technical Notes

Special inch and metric bores, keyways, set

Order No.	d ₁	d ₂	d ₃	d ₄	d ₅	h ₁	h ₂	h ₃	l ₁	l ₂	s ₁	Weight g
75340.W0065	21	M 6	27	18	16	50	23	20	87	65	8x8	78
75340.W0080	21	M 6	30	22	19	50	26	22	105	80	10x10	102
75340.W0100	23	M 8	34	24	22	70	30	27	128	100	12x12	167
75340.W0130	26	M 8	40	28	25	90	35	30	162	130	14x14	236
75340.W0160	26	M10	45	34	28	90	40	34	196	160	17x17	367



75360

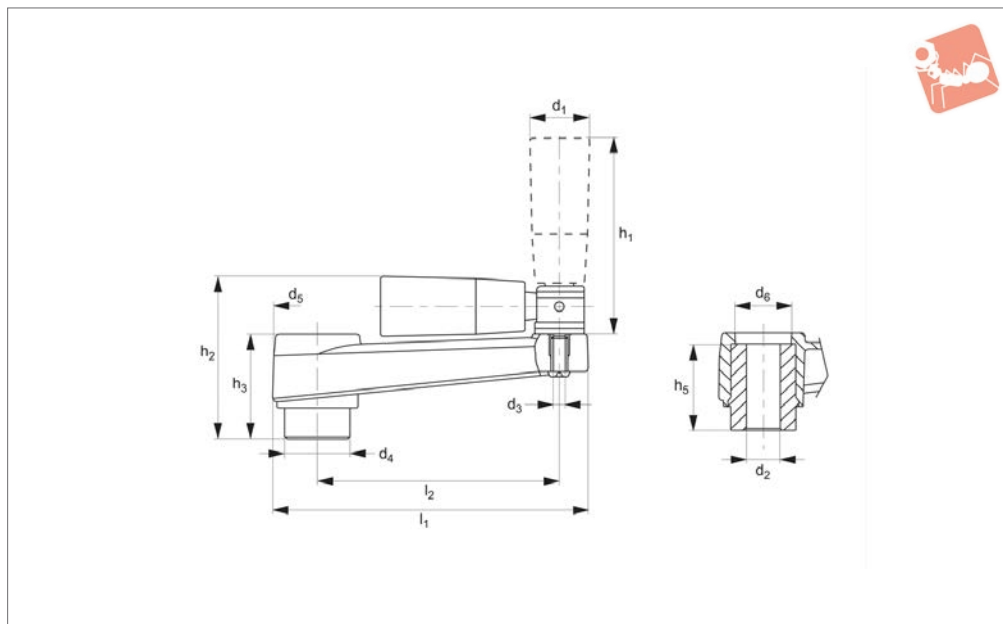

Material

Thermoplastic, black matt. Glass fibre reinforced. With fold-away revolving grip. Revolving grip and handle arm: thermo-

plast, black matte.

Technical Notes

Circular bore.

Tips

Fold-away grip can be retracted after use to ensure safety or where space is limited.

Order No.	d ₁	d ₂	d ₃	d ₄	d ₅	d ₆	h ₁	h ₂	h ₃	h ₅	l ₁	l ₂	Weight g
75360.W0080	10	10	M 5	22	30	19	50	63	36	32	105	80	125
75360.W0100	10	12	M 6	24	34	22	70	72	40	37	128	100	220
75360.W0130	14	14	M 6	28	40	25	70	83	49	44	162	130	312
75360.W0160	15	16	M 6	34	45	28	90	93	55	49	196	160	518



Cylindrical Handles

moulded thread

Cranked & Revolving

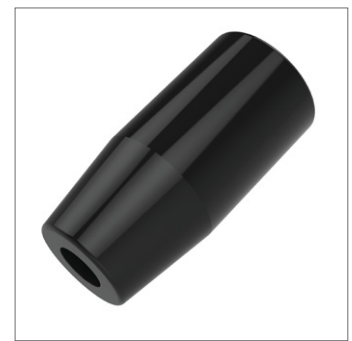
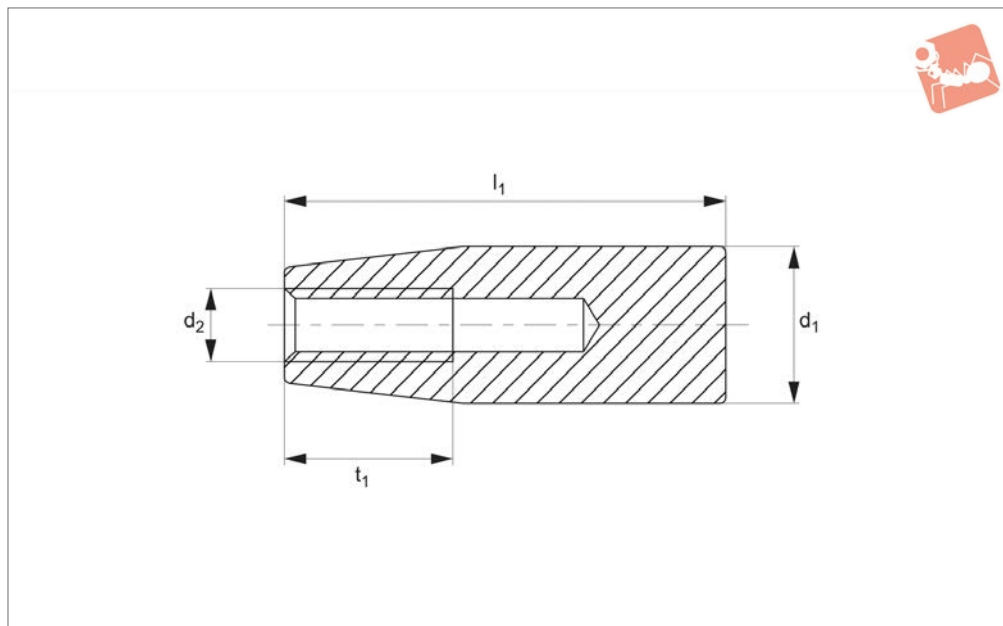

75010

CRANKED & REVOLVING HANDLES

Material

Duroplast, black, moulded thread.

request, subject to minimum order quantity.

Technical Notes

Special sizes and colours available on

Order No.	d_1	d_2	l_1	t_1	Weight g
75010.W0013	13	M 5	27	14	4
75010.W0014	13	M 6	27	14	4
75010.W0017	17	M 6	40	20	9
75010.W0018	17	M 8	40	25	8
75010.W0021	21	M 6	50	25	20
75010.W0022	21	M 8	50	25	19
75010.W0023	21	M10	50	25	18
75010.W0025	25	M 8	65	30	36
75010.W0026	25	M10	65	30	35
75010.W0027	25	M12	65	30	34
75010.W0028	28	M 8	85	40	61
75010.W0029	28	M10	85	40	59
75010.W0030	28	M12	85	40	56
75010.W0031	28	M14	85	40	52



75012

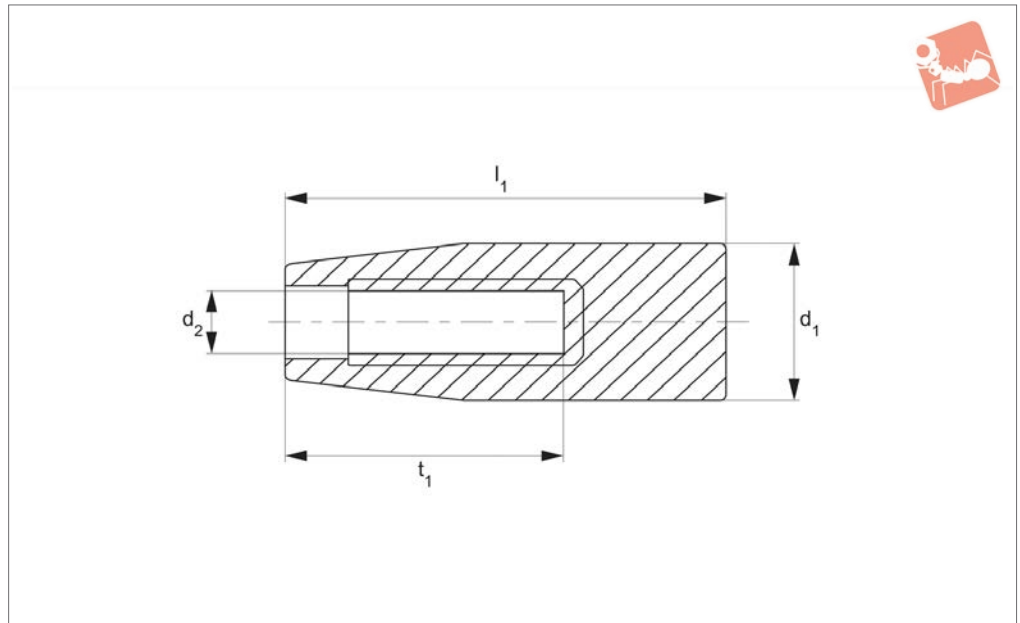

Material

Phenolic plastic, black.

request, subject to minimum order quantity.

Technical Notes

Special sizes and colours available on

Order No.	d ₁	d ₂	l ₁	t ₁	Weight g
75012.W1705	17	5	40	21	9
75012.W1706	17	6	40	21	9
75012.W2108	21	8	50	28	20
75012.W2110	21	10	50	28	18
75012.W2308	23	8	55	28	27
75012.W2310	23	10	55	28	25
75012.W2510	25	10	65	30	36
75012.W2512	25	12	65	30	35
75012.W2812	28	12	85	45	58
75012.W2814	28	14	85	45	55
75012.W2912	29	12	115	45	89
75012.W2914	29	14	115	45	84

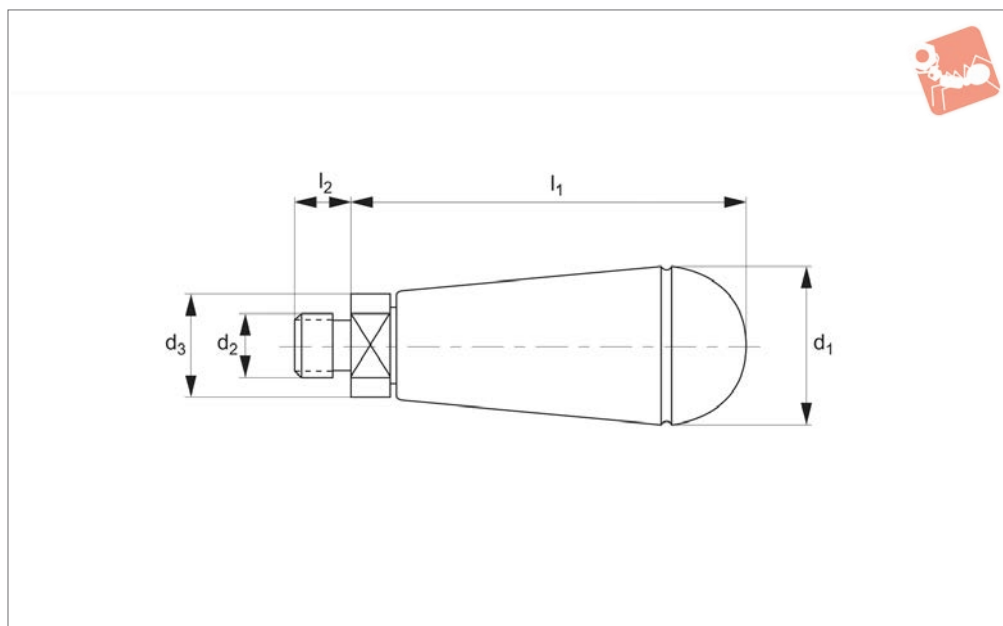

75020

CRANKED & REVOLVING HANDLES

Material

Black, duroplast, with zinc plated steel stud.

Order No.	d ₁	d ₂	d ₃	l ₁	l ₂	Weight g
75020.W0025	25	M 8	16	61	10	52
75020.W0026	25	M10	16	61	10	55
75020.W0032	32	M10	20	75	13	110
75020.W0033	32	M12	20	75	13	114



75060

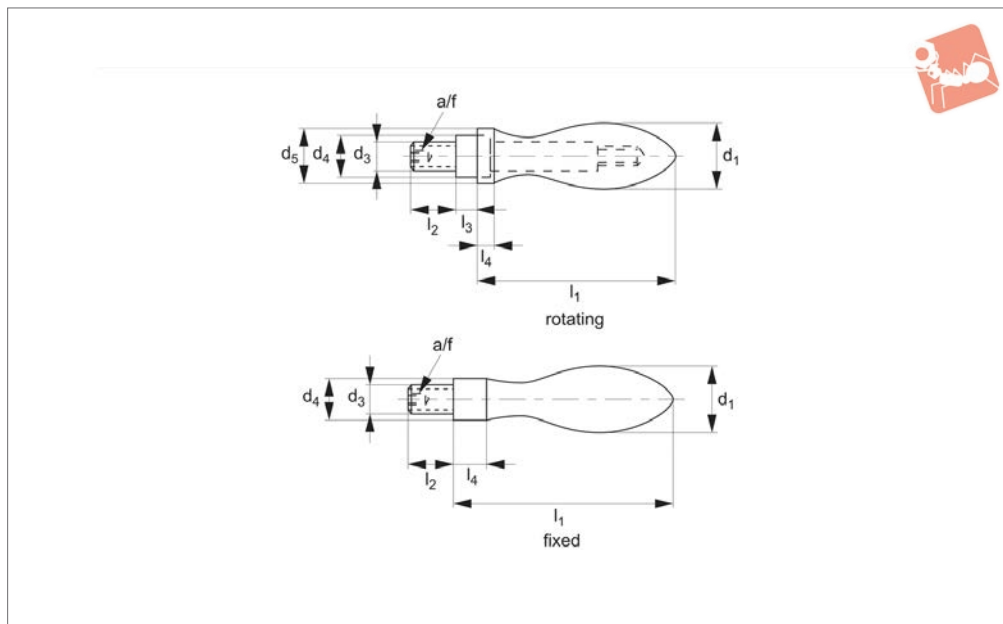

Material

Steel, turned, zinc coated by galvanization, passivated.

Order No.	Type	d ₁	d ₃	d ₄ tol. H13	d ₅	l ₁ ≈	l ₂	l ₃	l ₄	A/F	Weight g
75060.W0116	Rotating	16	M 6	10	14	49	11	5.5	5.0	3	51
75060.W0120	Rotating	20	M 8	13	18	61	13	6.0	6.0	4	101
75060.W0125	Rotating	25	M10	16	21	75	14	8.0	6.5	5	193
75060.W0132	Rotating	32	M12	20	26	95	21	10.5	8.0	6	387
75060.W0136	Rotating	36	M16	22	29	106	26	11.0	9.0	8	566
75060.W0216	Fixed	16	M 6	10	-	50	11	-	7.0	3	43
75060.W0220	Fixed	20	M 8	13	-	64	13	-	8.0	4	88
75060.W0225	Fixed	25	M10	16	-	80	14	-	10.0	5	175
75060.W0232	Fixed	32	M12	20	-	100	21	-	13.0	6	346
75060.W0236	Fixed	36	M16	22	-	112	26	-	14.0	8	509
75060.W0316	Stainless	16	M 6	10	-	50	11	-	7.0	-	45
75060.W0320	Stainless	20	M 8	13	-	64	13	-	8.0	-	92
75060.W0325	Stainless	25	M10	16	-	80	14	-	10.0	-	186

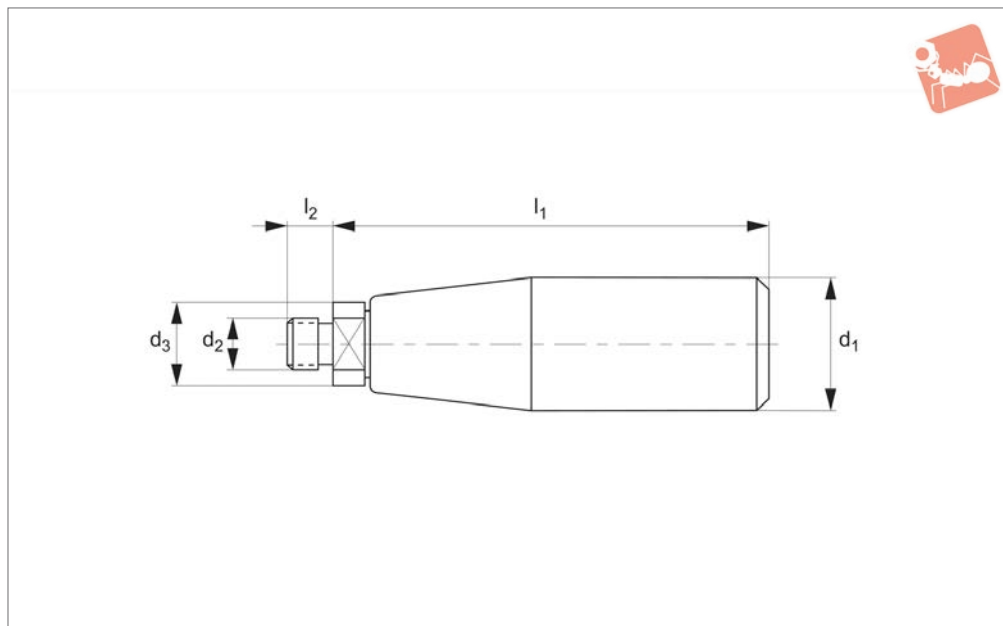

75100

CRANKED & REVOLVING HANDLES

Material

Black, duroplast. Zinc plated steel stud.

request, subject to minimum order quantity.

Technical Notes

Special sizes and colours available on

Order No.	d ₁	d ₂	d ₃	l ₁	l ₂
75100.W0117	17	M_6	12	45	8
75100.W0118	17	M_8	12	45	8
75100.W0121	21	M_8	16	56	10
75100.W0122	21	M10	16	56	10
75100.W0125	25	M_8	18	71	13
75100.W0126	25	M10	18	71	13
75100.W0128	28	M10	20	92	13
75100.W0129	28	M12	20	92	13



75120

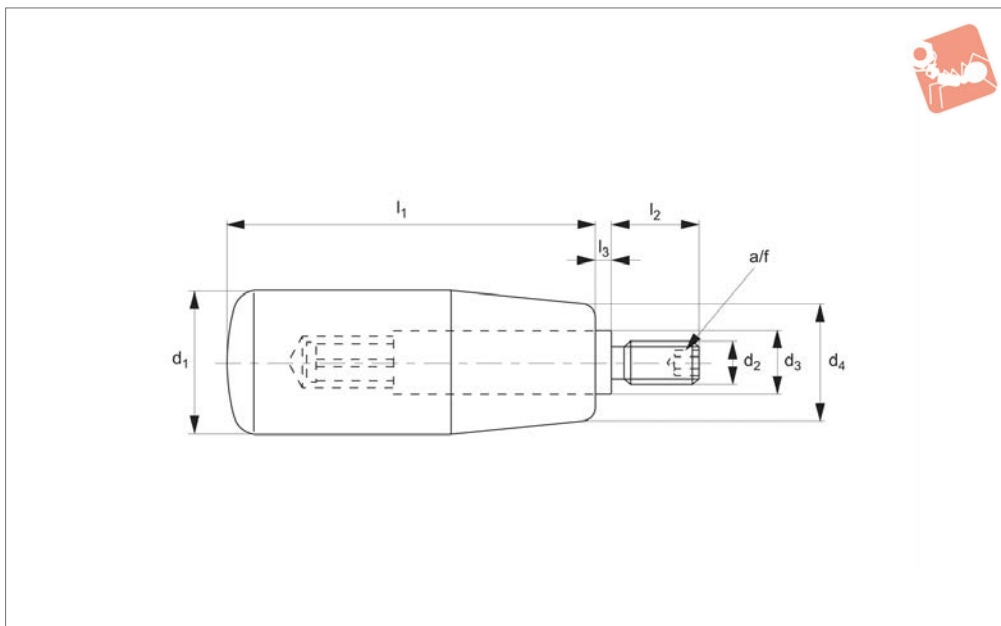

Material

Grip: duroplast PF 31, black matte. 75120.
W0014 - Thermoplastic (PA).

Stud & housing: steel, galvanised.

Technical Notes

Temperature range up to 80°C.

Order No.	d ₁	d ₂	d ₃	d ₄	l ₁	l ₂	l ₃	A/F	Weight g
75120.W0014	14	M_6	8	11	28	10	0.5	3	13
75120.W0018	18	M_6	10	15	40	12	2.5	3	29
75120.W0020	21	M_6	10	17	50	13	2.5	3	42
75120.W0022	22	M_6	10	18	56	13	2.5	3	47
75120.W0023	23	M_8	13	19	65	14	2.5	4	79
75120.W0026	26	M_8	13	21	80	16	2.5	4	106
75120.W0031	31	M12	14	25	102	20	2.5	6	178
75120.W0120	21	M_8	10	17	50	13	2.5	4	43
75120.W0122	22	M_8	10	18	56	13	2.5	4	48
75120.W0028	28	M10	13	22	90	16	2.5	5	126
75120.W0123	23	M10	13	19	65	14	2.5	5	80
75120.W0126	26	M10	13	21	80	16	2.5	5	108

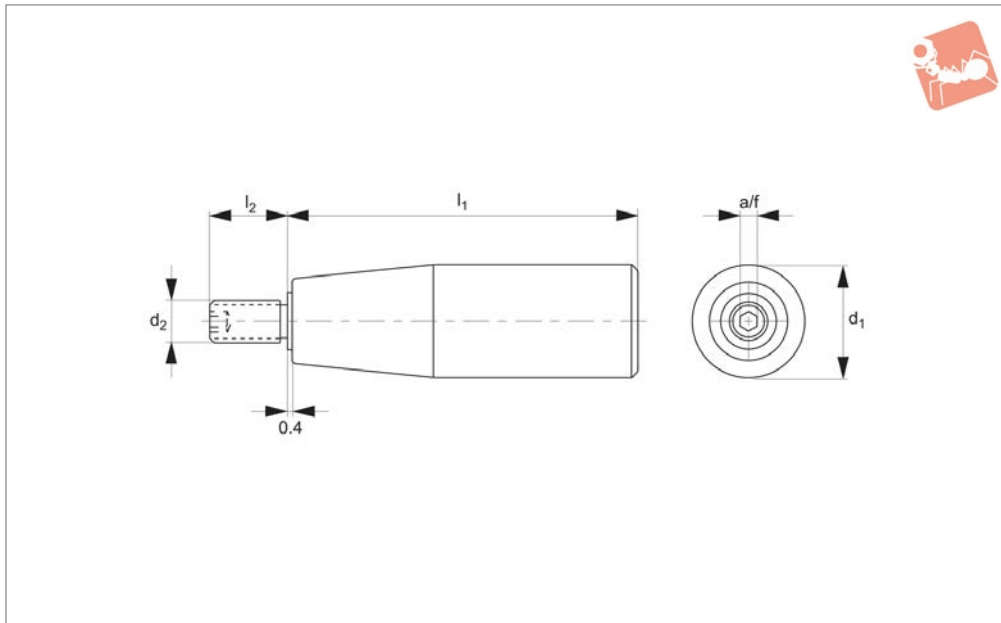

75130

CRANKED & REVOLVING HANDLES

Material

Grip: duroplast PF 31, black matt.
Stud & housing: stainless steel, AISI 303.

Technical Notes

Temperature range 110°C. For certain minimum quantities custom colours

available upon request.

Order No.	d_1	d_2	l_1	l_2	A/F	Weight g
75130.W0017	17	M 6	40	13	3	18
75130.W0020	21	M 6	50	13	3	35
75130.W0023	23	M 8	55	14	4	49
75130.W0025	25	M 8	65	15	4	73
75130.W0027	28	M 8	85	15	4	106
75130.W0028	28	M10	85	17	5	110



75150

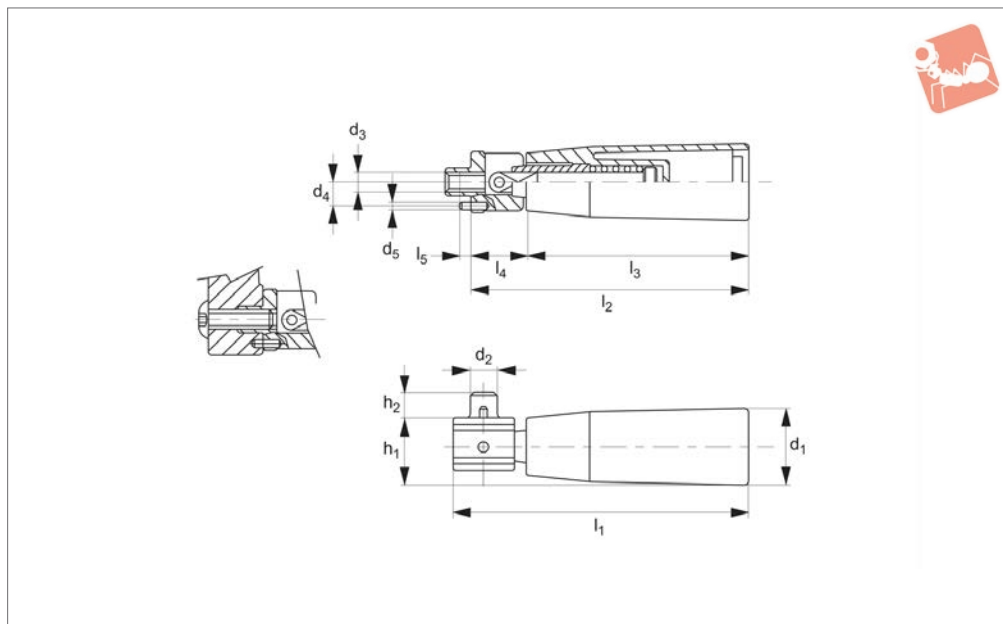

Material

Steel Type: Grip: thermoplastic, black, matt.

Stud & housing: steel, chrome plated.

Stainless Type: Grip: thermoplastic, black, matte.

Stud & housing: stainless steel, AISI 303. With retractable mechanism.

Technical Notes

Fold-away handles are ideal for applications where, due to lack of space or for

safety, the handle must be folded down and out of the way. Handle spring loaded for quick return. For certain minimum quantities custom colours available upon request.

Order No.	Material	d ₁	d ₂	d ₃	d ₄	d ₅	h ₁	h ₂	l ₁	l ₂	l ₃	l ₄	l ₅	Weight g
75150.W0021	Steel	21	7	M 5	6.3	2.5	19	8	69	66.5	50	16.5	4	55
75150.W0023	Steel	23	8	M 6	7.5	2.5	21	8	92	86.5	70	16.5	4	67
75150.W0026	Steel	26	8	M 6	7.5	2.5	24	10	114	110.0	90	20.0	4	102
75150.W0521	Stainless	21	7	M 5	6.3	2.5	19	8	69	66.5	50	16.5	4	55
75150.W0523	Stainless	23	8	M 6	7.5	2.5	21	8	92	86.5	70	16.5	4	67
75150.W0526	Stainless	26	8	M 6	7.5	2.5	24	10	114	110.0	90	20.0	4	102

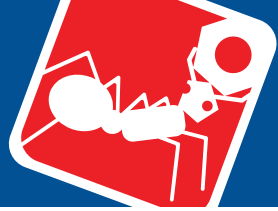

Rotating Handles

fold-away type

Cranked & Revolving

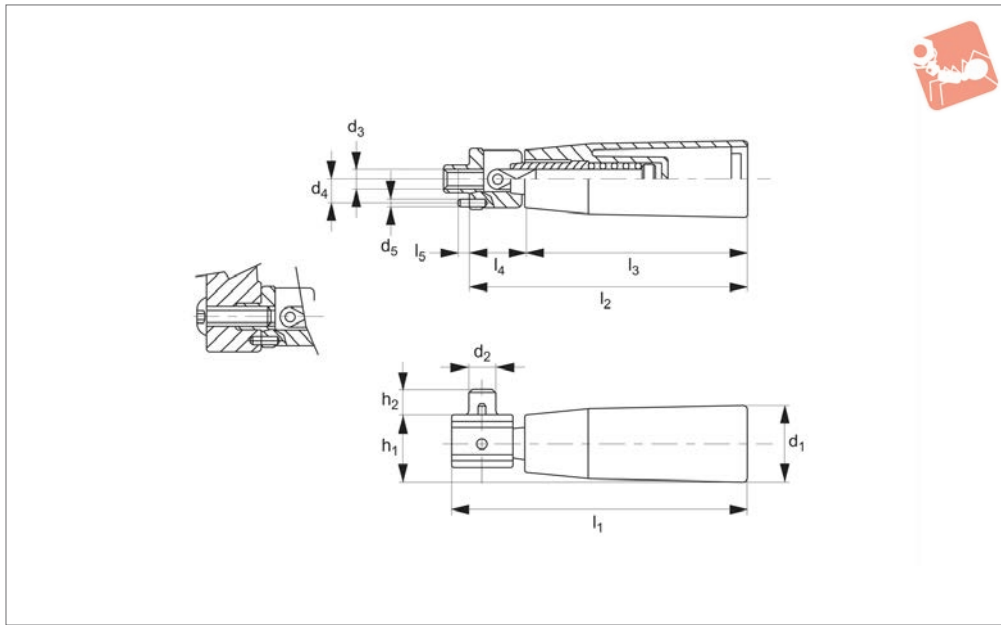

75160

CRANKED & REVOLVING HANDLES

Material

Thermoplastic, black, matt. Steel stud and zinc plated steel retractable mechanism.

Technical Notes

Fold-away handles are ideal for applica-

tions where, due to lack of space or for safety, the handle must be folded down and out of the way. Handle spring loaded for quick return. For certain minimum quantities custom colours available upon

request.

Order No.	d ₁	d ₂	d ₃	d ₄	d ₅	h ₁	h ₂	l ₁	l ₂	l ₃	l ₄	l ₅	Weight g
75160.W0021	21	7	M 5	6.3	2.5	27	8	63	57	50	7	4	46
75160.W0023	23	8	M 5	7.5	2.5	29	8	84	77	70	7	4	63
75160.W0024	26	8	M 6	7.5	2.5	32	10	107	97	90	7	4	105

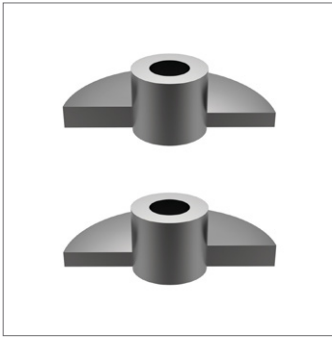

36820

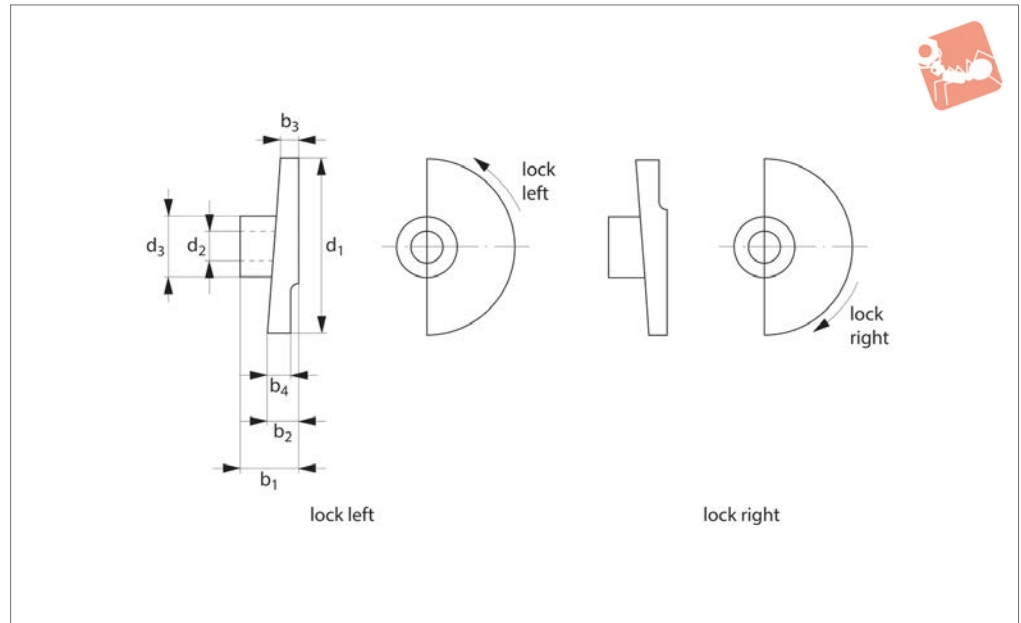

Material

Dry powdered metal.

Technical Notes

Not suitable for welding. Secure by using pins.

Order No.	Type	d ₁	d ₂ tol. H8	d ₃	b ₁	b ₂	b ₃	b ₄	Weight g
36820.W0008	Lock-right	35	8	18	15	7	3	7.0	30
36820.W0010	Lock-right	35	10	18	15	7	3	7.0	31
36820.W0012	Lock-right	65	12	23	20	10	5	7.2	103
36820.W0016	Lock-right	80	16	27	24	12	6	8.8	174
36820.W0108	Lock-left	35	8	18	15	7	3	7.0	34
36820.W0110	Lock-left	35	10	18	15	7	3	7.0	31
36820.W0112	Lock-left	65	12	23	20	10	5	7.2	103
36820.W0116	Lock-left	80	16	27	24	12	6	8.8	175

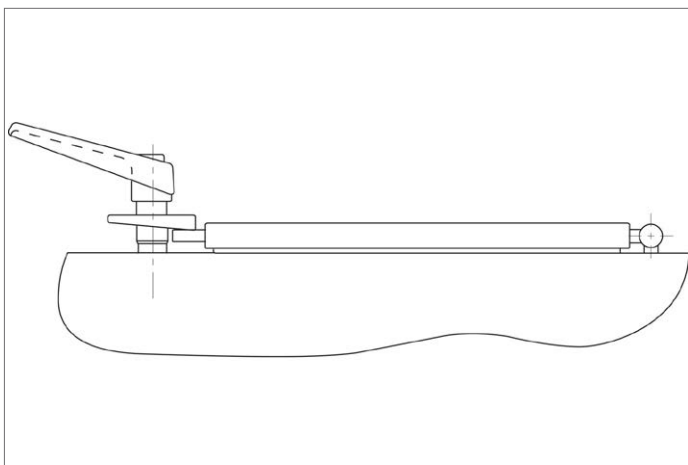

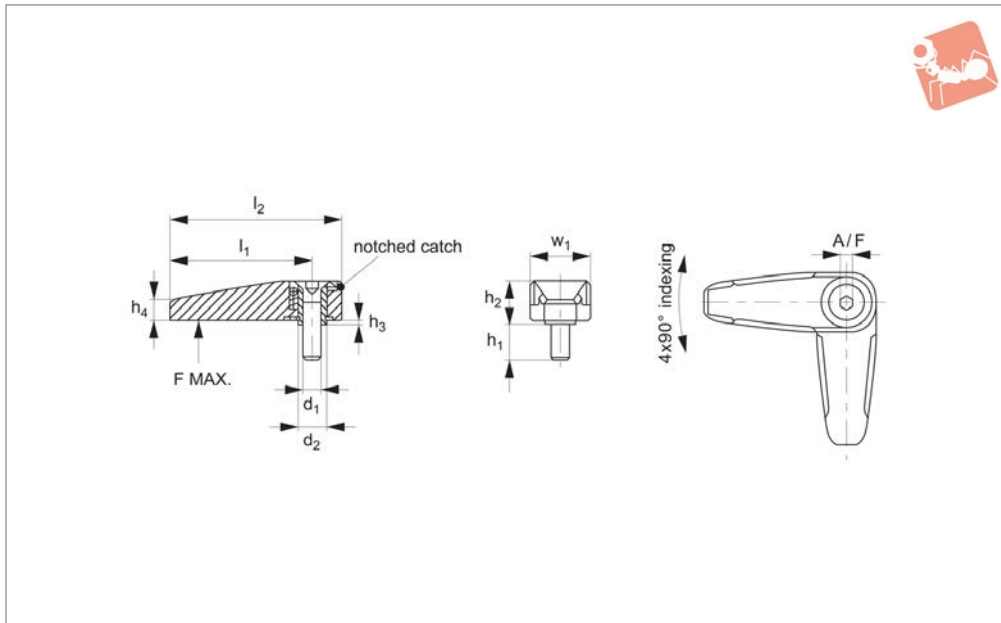

73900

RETAINING CATCHES

Material

Body: die cast zinc, black coated to RAL 9005 or silver coated to RAL 9006.
Fixing screw: stainless steel A2.

Inner parts: dry powdered metal.

Technical Notes

Quick retaining catch with positive index-

ing. Ideal for retaining doors, panels as well as for retaining parts during transportation.

Retaining catch is indexed 4x90°.

Order No.	Colour	d ₁	d ₂	l ₁	l ₂	h ₁	h ₂	h ₃	h ₄	Load F N max.	w ₁	A/F	Weight g
73900.W0101	Silver	M 6	9	45	55	12	13.3	0.8	6.5	500	19.0	4	59
73900.W0102	Black	M 6	9	45	55	12	13.3	0.8	6.5	500	19.0	4	59
73900.W0151	Silver	M 8	14	65	78	14	15.8	0.8	9.0	1000	25.2	5	136
73900.W0152	Black	M 8	14	65	78	14	15.8	0.8	9.0	1000	25.2	5	136

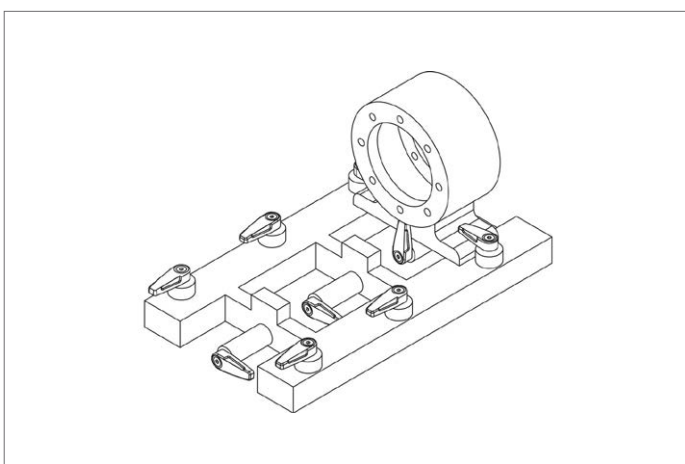

73900

Knobs, Handles & Handwheels



Retaining Catches



- Locking of panels and covers.
- Securing components during transport.
- Sturdy, solid design.
- Double sided model available.
- Indexes at 4 x 90°.

Models

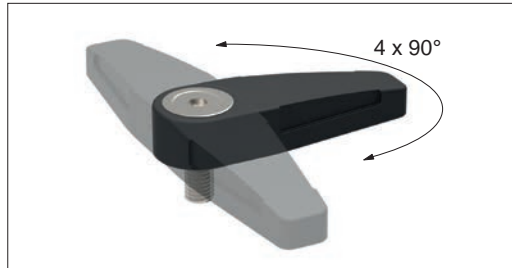

Single side

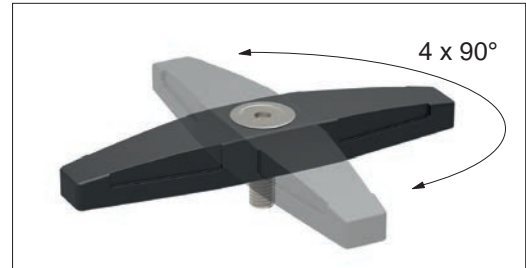

Double side

Applications

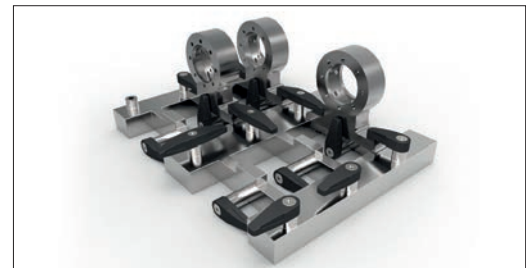
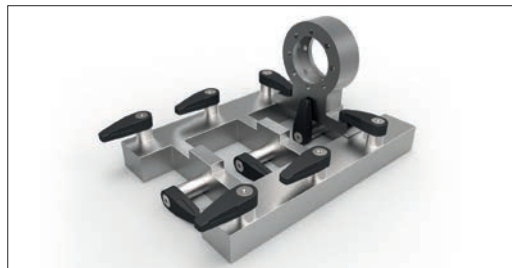

73906

Retaining Catches

- Locking of drawers.
- Securing of panels and covers.
- Simple operation.
- Indexes at 4 x 90°.
- Three mounting options.

Mounting options

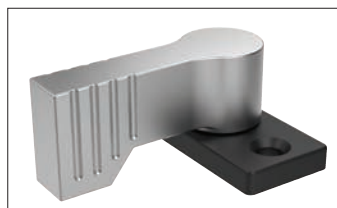

Flange

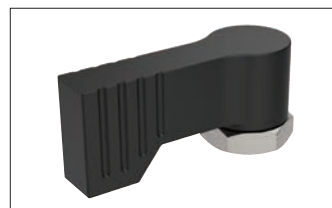

Female thread



Male thread

Applications





Retaining Catches

double-sided

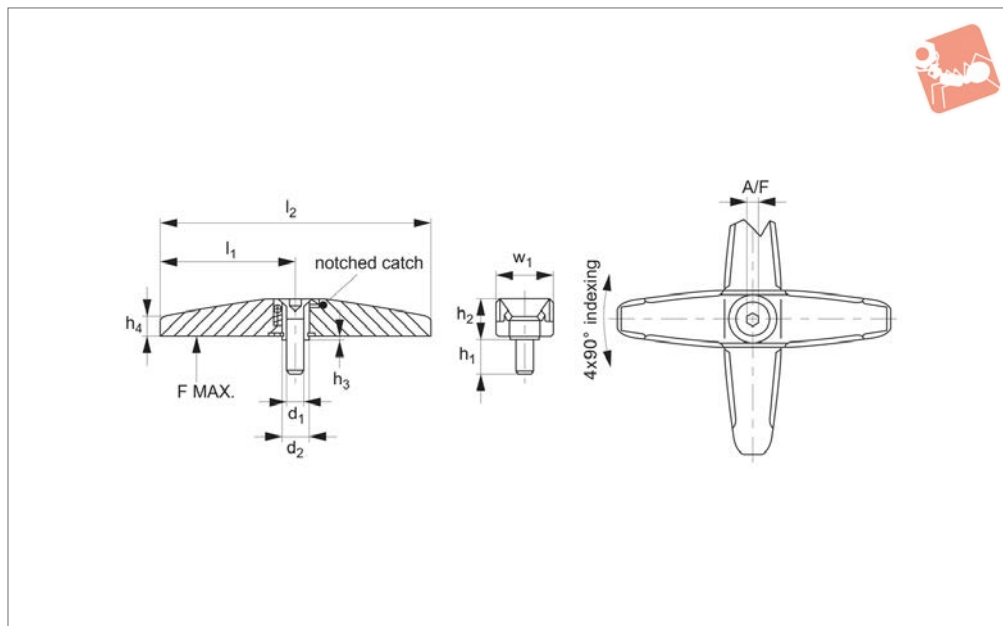

73902

RETAINING CATCHES

Material

Body: die cast zinc, black coated to RAL 9005 or silver coated to RAL 9006.
Fixing screw: stainless steel A2.

Inner parts: dry powdered metal.

Technical Notes

Quick retaining catch with positive index-

ing. Ideal for retaining doors, panels as well as for retaining parts during transportation.

Retaining catch is indexed 4x90°.

Order No.	Colour	d ₁	d ₂	l ₁	l ₂	h ₁	h ₂	h ₃	h ₄	Load F N max.	w ₁	A/F	Weight g
73902.W0601	Silver	M 6	9	45	90	12	13.3	0.8	6.5	500	19.0	4	93
73902.W0602	Black	M 6	9	45	90	12	13.3	0.8	6.5	500	19.0	4	93
73902.W0651	Silver	M 8	14	65	130	14	15.8	0.8	9.0	1000	25.2	5	220
73902.W0652	Black	M 8	14	65	130	14	15.8	0.8	9.0	1000	25.2	5	220

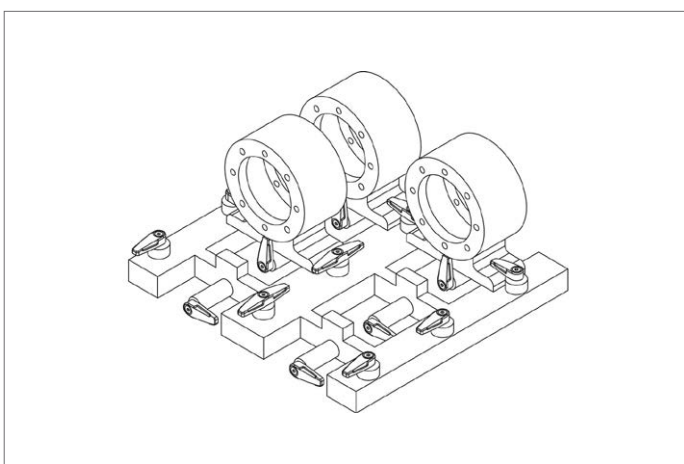



73906

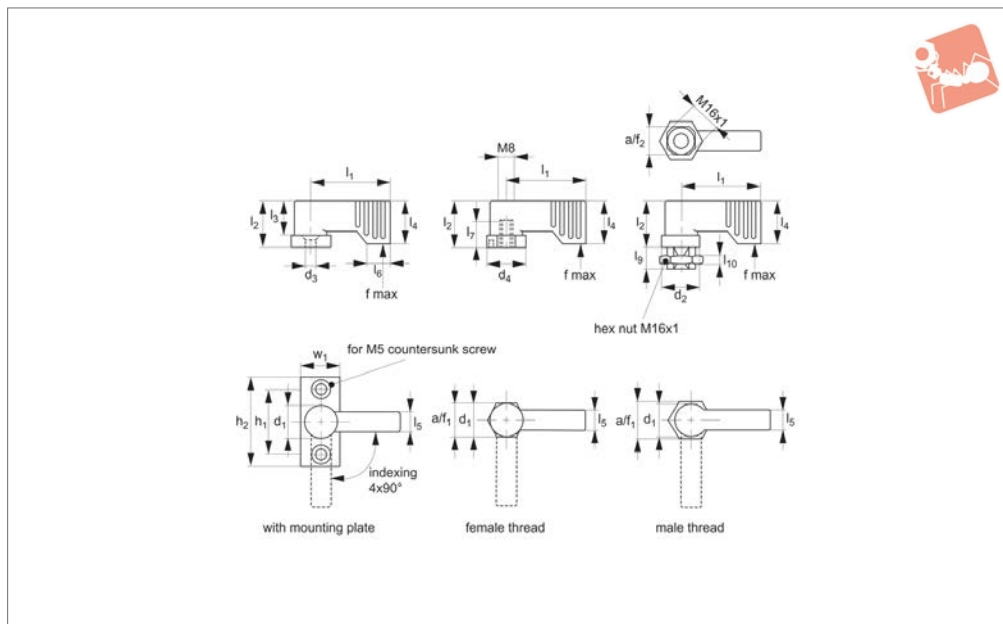

Material

Lever: die-cast Zinc, plastic coated silver (RAL9006) or black (RAL 9005) matte finish.

Flange: die-cast Zinc, plastic coated, black.

as a support during transports etc. The retaining catch indexes at 4x90°.

Technical Notes

To be used for locking doors, drawers and

Order No.	Colour	Type	d ₁	d ₂	d ₃	d ₄ ≈	d ₅	d ₆ tol. H11	l ₁	l ₂ ≈	l ₃	l ₄ min.	Weight g
73906.W0201	Silver	Mounting Plate	17	-	5.3	-	-	-	40	22	16.5	21.5	20
73906.W0202	Black	Mounting Plate	17	-	5.3	-	-	-	40	22	16.5	21.5	20
73906.W0232	Black	Female Thread	17	-	-	20	7	2	40	22	16.5	21.5	30
73906.W0262	Black	Male Thread	17	19	-	-	-	-	40	22	16.5	21.5	50
73906.W0231	Silver	Female Thread	17	-	-	20	7	2	40	22	16.5	21.5	30
73906.W0261	Silver	Male Thread	17	19	-	-	-	-	40	22	16.5	21.5	50

Order No.	l ₅	l ₆	l ₇	l ₈	l ₉	l ₁₀	h ₁	h ₂	w ₁	A/F ₁	A/F ₂	Load f max. N
73906.W0201	10	11	-	-	-	-	32	45	20	-	-	450
73906.W0202	10	11	-	-	-	-	32	45	20	-	-	450
73906.W0232	10	11	11	4	-	-	-	-	-	17	-	450
73906.W0262	10	11	-	-	9	3	-	-	-	19	14	450
73906.W0231	10	11	11	4	-	-	-	-	-	17	-	450
73906.W0261	10	11	-	-	9	3	-	-	-	19	14	450



Levelling Feet - Bolt Down pad and bolt steel

Levelling Feet

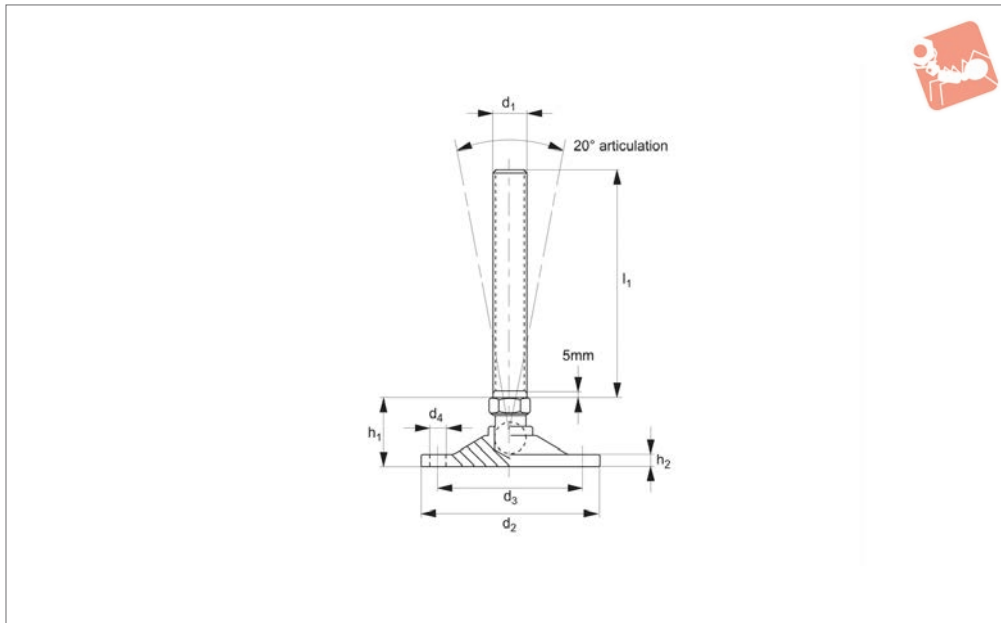

34702

LEVELLING FEET

Material

Pad and bolt: mild steel, nickel plated.

Technical Notes

Bolt has a 20° angle of movement.

Order No.	d ₁	d ₂	d ₃	d ₄	h ₁	h ₂	l ₁	Static load kN max.
34702.W0508	M 8	50	40	5.5	22	4.0	60	3.0
34702.W0600	M10	50	40	5.5	22	4.0	75	5.0
34702.W0621	M12	60	50	5.5	25	5.0	75	12.5
34702.W0622	M12	60	50	5.5	25	5.0	125	12.5
34702.W0623	M12	60	50	5.5	25	5.0	150	12.5
34702.W0660	M16	80	68	6.5	31	6.0	75	17.5
34702.W0661	M16	80	68	6.5	31	6.0	125	17.5
34702.W0662	M16	80	68	6.5	31	6.0	150	17.5
34702.W0700	M20	100	82	9.0	39	6.5	125	25.0
34702.W0701	M20	100	82	9.0	39	6.5	150	25.0
34702.W0702	M20	100	82	9.0	39	6.5	200	25.0
34702.W0741	M24	120	100	11.0	56	7.5	150	37.5
34702.W0742	M24	120	100	11.0	56	7.5	200	37.5



34703

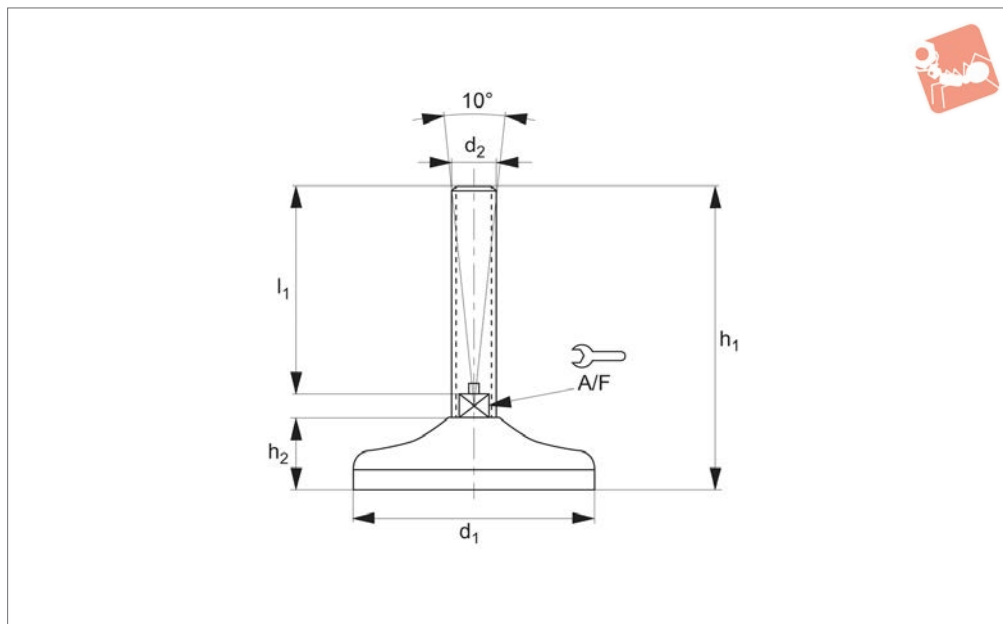

Material

Galvanized steel (C40), with rubber pad (70 shore A).

Technical Notes

Load values refer to static loads, located at half the screw height.

Order No.	d ₁	d ₂	h ₁	h ₂	l ₁	A/F	Load kgf max.
34703.W1200	50	M12	79	19	50	14	400
34703.W1201	50	M12	129	19	100	14	400
34703.W1202	50	M12	179	19	150	14	400
34703.W1400	50	M14	79	19	50	14	400
34703.W1401	50	M14	129	19	100	14	400
34703.W1402	50	M14	179	19	150	14	400
34703.W1600	50	M16	104	19	75	14	400
34703.W1601	50	M16	129	19	100	14	400
34703.W1602	50	M16	179	19	150	14	400
34703.W1002	80	M10	85	25	50	14	1000
34703.W1003	80	M10	135	25	100	14	1000
34703.W1203	80	M12	85	25	50	14	1000
34703.W1204	80	M12	135	25	100	14	1000
34703.W1205	80	M12	185	25	150	14	1000
34703.W1403	80	M14	85	25	50	14	1000
34703.W1404	80	M14	135	25	100	14	1000
34703.W1405	80	M14	185	25	150	14	1000
34703.W1603	80	M16	85	25	75	14	1000
34703.W1605	80	M16	185	25	150	14	1000
34703.W2000	80	M20	111	25	75	14	1000
34703.W2001	80	M20	136	25	100	14	1000
34703.W2002	80	M20	186	25	150	14	1000
34703.W2003	80	M20	236	25	200	14	1000
34703.W2400	80	M24	111	25	75	14	1000
34703.W2401	80	M24	136	25	100	14	1000
34703.W2402	80	M24	186	25	150	14	1000
34703.W2403	80	M24	236	25	200	14	1000
34703.W1606	100	M16	112.5	28	75	16	1500
34703.W1607	100	M16	137.5	28	100	16	1500
34703.W1608	100	M16	187.5	28	150	16	1500
34703.W1609	100	M16	237.5	28	200	16	1500
34703.W2004	100	M20	113.5	28	75	20	1500
34703.W2005	100	M20	138.5	28	100	20	1500
34703.W2006	100	M20	188.5	28	150	20	1500



Order No.	d ₁	d ₂	h ₁	h ₂	l ₁	A/F	Load kgf max.
34703.W2007	100	M20	238.5	28	200	20	1500
34703.W2008	100	M20	288.5	28	250	20	1500
34703.W2404	100	M24	138.5	28	100	24	1500
34703.W2405	100	M24	188.5	28	150	24	1500
34703.W2406	100	M24	238.5	28	200	24	1500
34703.W2407	100	M24	288.5	28	250	24	1500
34703.W3000	100	M30	139.5	28	100	30	1500
34703.W3001	100	M30	189.5	28	150	30	1500
34703.W3002	100	M30	239.5	28	200	30	1500
34703.W3003	100	M30	289.5	28	250	30	1500
34703.W1610	120	M16	116.5	32	75	16	3000
34703.W1611	120	M16	141.5	32	100	16	3000
34703.W1612	120	M16	191.5	32	150	16	3000
34703.W1613	120	M16	241.5	32	200	16	3000
34703.W2009	120	M20	117.5	32	75	20	3000
34703.W2010	120	M20	142.5	32	100	20	3000
34703.W2011	120	M20	192.5	32	150	20	3000
34703.W2012	120	M20	242.5	32	200	20	3000
34703.W2013	120	M20	292.5	32	250	20	3000
34703.W2408	120	M24	142.5	32	100	24	3000
34703.W2409	120	M24	192.5	32	150	24	3000
34703.W2410	120	M24	242.5	32	200	24	3000
34703.W2411	120	M24	292.5	32	250	24	3000
34703.W3004	120	M30	143.5	32	100	30	3000
34703.W3005	120	M30	193.5	32	150	30	3000
34703.W3006	120	M30	243.5	32	200	30	3000
34703.W3007	120	M30	293.5	32	250	30	3000

LEVELLING FEET



34704

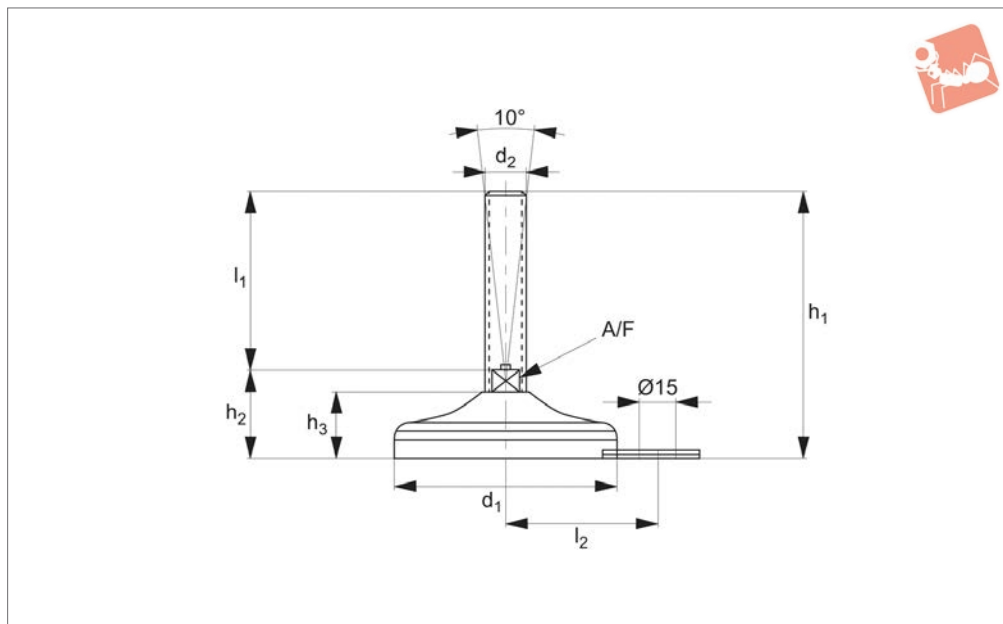

Material

Base material: galvanized steel (C40).
Full Steel base with vulcanized rubber.

half the screw height.

In conditions of vibrations or in presence of dynamic loads these values should be reduced.

Technical Notes

Load values refer to static loads, located at

Order No.	d ₁	d ₂	h ₁	h ₂	h ₃	l ₁	l ₂	A/F	Load kgf max.	Weight g
34704.W1200	80	M12	85.0	35.0	25	50	54	14	1000	303
34704.W1201	80	M12	135.0	35.0	25	100	54	14	1000	335
34704.W1202	80	M12	185.0	35.0	25	150	54	14	1000	372
34704.W1400	80	M14	85.0	35.0	25	50	54	14	1000	316
34704.W1401	80	M14	135.0	35.0	25	100	54	14	1000	363
34704.W1402	80	M14	185.0	35.0	25	150	54	14	1000	413
34704.W1600	80	M16	110.0	35.0	25	75	54	16	1000	367
34704.W1601	80	M16	135.0	35.0	25	100	54	16	1000	399
34704.W1602	80	M16	185.0	35.0	25	150	54	16	1000	464
34704.W1603	80	M16	235.0	35.0	25	200	54	16	1000	527
34704.W2000	80	M20	111.0	36.0	25	75	54	20	1000	430
34704.W2001	80	M20	136.0	36.0	25	100	54	20	1000	480
34704.W2002	80	M20	186.0	36.0	25	150	54	20	1000	582
34704.W2003	80	M20	236.0	36.0	25	200	54	20	1000	683
34704.W2400	80	M24	111.0	36.0	25	75	54	24	1000	503
34704.W2401	80	M24	136.0	36.0	25	100	54	24	1000	576
34704.W2402	80	M24	186.0	36.0	25	150	54	24	1500	721
34704.W2403	80	M24	236.0	36.0	25	200	54	24	1500	867
34704.W1604	100	M16	112.5	37.5	28	75	69	16	1500	505
34704.W1605	100	M16	137.5	37.5	28	100	69	16	1500	537
34704.W1606	100	M16	187.5	37.5	28	150	69	16	1500	602
34704.W1607	100	M16	237.5	37.5	28	200	69	16	1500	665
34704.W2004	100	M20	113.5	38.5	28	75	69	20	1500	568
34704.W2005	100	M20	138.5	38.5	28	100	69	20	1500	618
34704.W2006	100	M20	188.5	38.5	28	150	69	20	1500	720
34704.W2007	100	M20	238.5	38.5	28	200	69	20	1500	821
34704.W2008	100	M20	288.5	38.5	28	250	69	20	1500	924
34704.W2404	100	M24	138.5	38.5	28	100	69	24	1500	641
34704.W2405	100	M24	188.5	38.5	28	150	69	24	1500	714
34704.W2406	100	M24	238.5	38.5	28	200	69	24	1500	859
34704.W2407	100	M24	288.5	38.5	28	250	69	24	1500	1005



Order No.	d ₁	d ₂	h ₁	h ₂	h ₃	l ₁	l ₂	A/F	Load kgf max.	Weight g
34704.W3000	100	M30	139.5	39.5	28	100	69	30	1500	906
34704.W3001	100	M30	189.5	39.5	28	150	69	30	1500	1139
34704.W3002	100	M30	239.5	39.5	28	200	69	30	1500	1363
34704.W3003	100	M30	289.5	39.5	28	250	69	30	1500	1593



34705

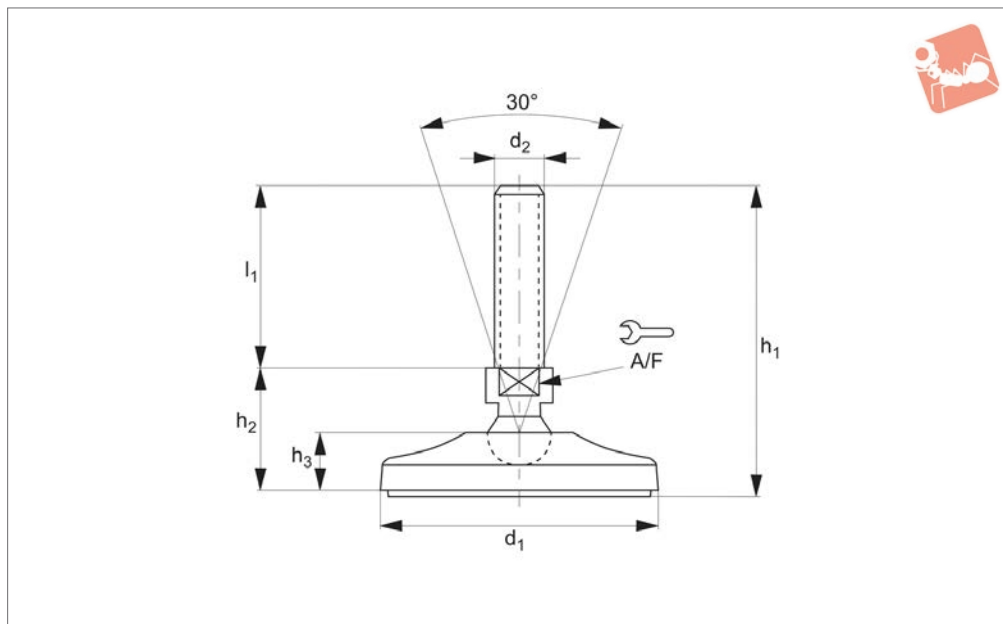

Material

Steel (C40), powder coated (RAL 1007), with rubber pad (70 shore A).

Technical Notes

Load values refer to static loads, located at half the screw height.

Order No.	d ₁	d ₂	h ₁	h ₂	h ₃	l ₁	A/F	Load kgf max.
34705.W1000	50	M10	56	31	19	25	14	1500
34705.W1001	50	M10	81	31	19	50	14	1500
34705.W1003	50	M10	131	31	19	100	14	1500
34705.W1200	50	M12	56	31	19	25	14	1500
34705.W1201	50	M12	81	31	19	50	14	1500
34705.W1202	50	M12	106	31	19	75	14	1500
34705.W1203	50	M12	131	31	19	100	14	1500
34705.W1204	50	M12	156	31	19	125	14	1500
34705.W1400	50	M14	56	31	19	25	14	1500
34705.W1401	50	M14	81	31	19	50	14	1500
34705.W1402	50	M14	106	31	19	75	14	1500
34705.W1403	50	M14	131	31	19	100	14	1500
34705.W1404	50	M14	156	31	19	125	14	1500
34705.W1405	65	M14	83	33	20	50	16	2000
34705.W1406	65	M14	108	33	20	75	16	2000
34705.W1407	65	M14	133	33	20	100	16	2000
34705.W1408	65	M14	158	33	20	125	16	2000
34705.W1409	65	M14	183	33	20	150	16	2000
34705.W1600	65	M16	83	33	20	50	16	2000
34705.W1601	65	M16	108	33	20	75	16	2000
34705.W1602	65	M16	133	33	20	100	16	2000
34705.W1603	65	M16	158	33	20	125	16	2000
34705.W1604	65	M16	183	33	20	150	16	2000
34705.W1605	65	M16	208	33	20	175	16	2000
34705.W1606	80	M16	86	36	23	50	16	3000
34705.W1607	80	M16	111	36	23	75	16	3000
34705.W1608	80	M16	136	36	23	100	16	3000
34705.W1609	80	M16	161	36	23	125	16	3000
34705.W1610	80	M16	186	36	23	150	16	3000
34705.W1611	80	M16	211	36	23	175	16	3000
34705.W1612	80	M16	236	36	23	200	16	3000
34705.W2000	80	M20	114	39	23	75	17	3000
34705.W2001	80	M20	139	39	23	100	17	3000
34705.W2002	80	M20	164	39	23	125	17	3000



Order No.	d ₁	d ₂	h ₁	h ₂	h ₃	l ₁	A/F	Load kgf max.
34705.W2003	80	M20	189	39	23	150	17	3000
34705.W2004	80	M20	214	39	23	175	17	3000
34705.W2005	80	M20	239	39	23	200	17	3000
34705.W2006	80	M20	264	39	23	225	17	3000
34705.W1613	100	M16	96	46	23	50	20	3500
34705.W1614	100	M16	121	46	23	75	20	3500
34705.W1617	100	M16	196	46	23	150	20	3500
34705.W1618	100	M16	221	46	23	175	20	3500
34705.W1619	100	M16	246	46	23	200	20	3500
34705.W2007	100	M20	121	46	23	75	20	4500
34705.W2008	100	M20	146	46	23	100	20	4500
34705.W2009	100	M20	171	46	23	125	20	4500
34705.W2010	100	M20	196	46	23	150	20	4500
34705.W2011	100	M20	221	46	23	175	20	4500
34705.W2012	100	M20	246	46	23	200	20	4500
34705.W2013	100	M20	271	46	23	225	20	4500
34705.W2014	100	M20	296	46	23	250	20	4500
34705.W2400	100	M24	122	47	23	75	20	5500
34705.W2401	100	M24	147	47	23	100	20	5500
34705.W2402	100	M24	172	47	23	125	20	5500
34705.W2403	100	M24	202	47	23	150	20	5500
34705.W2404	100	M24	222	47	23	175	20	5500
34705.W2405	100	M24	247	47	23	200	20	5500
34705.W2406	100	M24	272	47	23	225	20	5500
34705.W2407	100	M24	297	47	23	250	20	5500
34705.W1620	120	M16	99	49	26	50	20	3500
34705.W1621	120	M16	104	49	26	75	20	3500
34705.W1622	120	M16	149	49	26	100	20	3500
34705.W1623	120	M16	174	49	26	125	20	3500
34705.W1624	120	M16	199	49	26	150	20	3500
34705.W1626	120	M16	249	49	26	200	20	3500
34705.W2015	120	M20	124	49	26	75	20	4500
34705.W2016	120	M20	149	49	26	100	20	4500
34705.W2017	120	M20	174	49	26	125	20	4500
34705.W2018	120	M20	199	49	26	150	20	4500
34705.W2019	120	M20	224	49	26	175	20	4500
34705.W2020	120	M20	249	49	26	200	20	4500
34705.W2021	120	M20	274	49	26	225	20	4500
34705.W2022	120	M20	299	49	26	250	20	4500
34705.W2408	120	M24	125	50	26	75	20	5500
34705.W2409	120	M24	150	50	26	100	20	5500
34705.W2410	120	M24	175	50	26	125	20	5500
34705.W2411	120	M24	200	50	26	150	20	5500
34705.W2412	120	M24	225	50	26	175	20	5500
34705.W2413	120	M24	250	50	26	200	20	5500
34705.W2414	120	M24	275	50	26	225	20	5500
34705.W2415	120	M24	300	50	26	250	20	5500
34705.W3000	120	M30	150	50	26	100	26	6500
34705.W3001	120	M30	175	50	26	125	26	6500
34705.W3002	120	M30	200	50	26	150	26	6500
34705.W3003	120	M30	225	50	26	175	26	6500
34705.W3004	120	M30	250	50	26	200	26	6500
34705.W3005	120	M30	275	50	26	225	26	6500
34705.W3006	120	M30	300	50	26	250	26	6500



34700

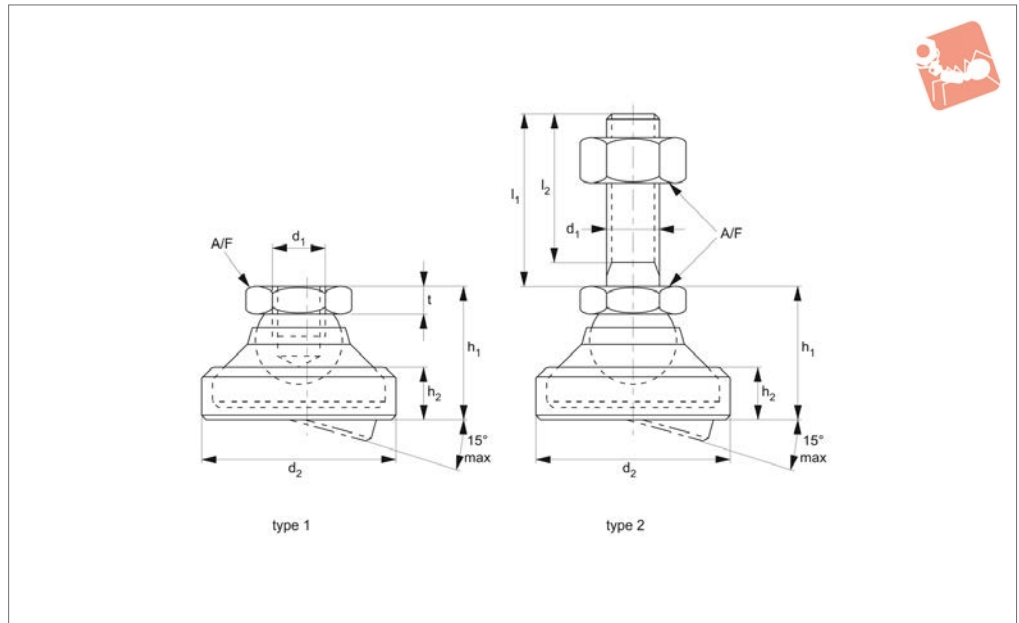

Material

Steel type

Ball: steel heat-treated, tempered, blackened.

Ball with bolt: heat-treated steel, tempered, blackened.

Lock nut: Steel blackened, ISO 4032/DIN 934 (M10, M12 only).

Pad: heat-treated steel, tempered,

blackened.

Stainless type

Pad: stainless steel 1.4305 (AISI 303).

Ball: stainless steel 1.4305 (AISI 303).

Ball with bolt: stainless steel 1.4305 (AISI 303).

Lock nut: Stainless steel A2, ISO 4032/DIN 934 (M10, M12 only).

Cap: Black rubber.

Tips

To be used as feet and thrust pads. Used for levelling up to 15° on surface. Rubber cap prevents reduces slipping.

Also used:

34761 - Levelling Feet - thermoplastic, non slip.

Order No.	Material	Type	d ₁	d ₂	h ₁	h ₂	l ₁	l ₂	t ₁	A/F	Static load kN max.	Weight g
34700.W1006	Steel	Pad	M 6	20	14	2.5	-	-	5.0	10	10	15
34700.W1008	Steel	Pad	M 8	25	18	4.0	-	-	7.0	13	18	33
34700.W1010	Steel	Pad	M10	32	22	5.0	-	-	9.0	17	20	66
34700.W1012	Steel	Pad	M12	40	26	6.0	-	-	11.0	19	35	112
34700.W1016	Steel	Pad	M16	50	32	7.0	-	-	13.5	24	45	220
34700.W1020	Steel	Pad	M20	60	42	8.0	-	-	17.0	30	55	413
34700.W1024	Steel	Pad	M24	60	45	9.5	-	-	19.0	36	65	462
34700.W1410	Steel	Pad and Bolt	M 6	20	14	2.5	60	57.0	-	10	10	29
34700.W1422	Steel	Pad and Bolt	M 8	25	18	4.0	80	76.0	-	13	18	66
34700.W1438	Steel	Pad and Bolt	M10	32	22	5.0	100	95.5	-	17	20	133
34700.W1442	Steel	Pad and Bolt	M10	32	22	5.0	150	145.5	-	17	20	159
34700.W1452	Steel	Pad and Bolt	M12	40	26	6.0	100	94.5	-	19	35	211
34700.W1456	Steel	Pad and Bolt	M12	40	26	6.0	150	144.5	-	19	35	247
34700.W1468	Steel	Pad and Bolt	M16	50	32	7.0	100	94.0	-	24	45	407
34700.W1472	Steel	Pad and Bolt	M16	50	32	7.0	200	194.0	-	24	45	540
34700.W1482	Steel	Pad and Bolt	M20	60	42	8.0	100	92.5	-	30	55	722
34700.W1488	Steel	Pad and Bolt	M20	60	42	8.0	200	192.5	-	30	55	924
34700.W1495	Steel	Pad and Bolt	M24	60	45	9.5	100	91.0	-	36	65	935
34700.W1498	Steel	Pad and Bolt	M24	60	45	9.5	200	191.0	-	36	65	1231
34700.W1206	Stainless Steel	Pad	M 6	20	14	2.5	-	-	5.0	10	8	15
34700.W1208	Stainless Steel	Pad	M 8	25	18	4.0	-	-	7.0	13	14	33
34700.W1210	Stainless Steel	Pad	M10	32	22	5.0	-	-	9.0	17	16	66
34700.W1212	Stainless Steel	Pad	M12	40	26	6.0	-	-	11.0	19	28	112
34700.W1216	Stainless Steel	Pad	M16	50	32	7.0	-	-	13.5	24	36	220
34700.W1220	Stainless Steel	Pad	M20	60	42	8.0	-	-	17.0	30	44	413
34700.W1224	Stainless Steel	Pad	M24	60	45	9.5	-	-	19.0	36	52	462
34700.W1610	Stainless Steel	Pad and Bolt	M 6	20	14	2.5	60	57.0	-	10	8	29



Levelling Feet - Non Slip pad and bolt - steel or stainless



Levelling Feet

Order No.	Material	Type	d ₁	d ₂	h ₁	h ₂	l ₁	l ₂	t ₁	A/F	Static load kN max.	Weight g
34700.W1622	Stainless Steel	Pad and Bolt	M 8	25	18	4.0	80	76.0	-	13	14	66
34700.W1638	Stainless Steel	Pad and Bolt	M10	32	22	5.0	100	95.5	-	17	16	133
34700.W1642	Stainless Steel	Pad and Bolt	M10	32	22	5.0	150	145.5	-	17	16	159
34700.W1652	Stainless Steel	Pad and Bolt	M12	40	26	6.0	100	94.5	-	19	28	211
34700.W1656	Stainless Steel	Pad and Bolt	M12	40	26	6.0	150	144.5	-	19	28	247
34700.W1668	Stainless Steel	Pad and Bolt	M16	50	32	7.0	100	94.0	-	24	36	407
34700.W1672	Stainless Steel	Pad and Bolt	M16	50	32	7.0	200	194.0	-	24	36	540
34700.W1682	Stainless Steel	Pad and Bolt	M20	60	42	8.0	100	92.5	-	30	44	722
34700.W1688	Stainless Steel	Pad and Bolt	M20	60	42	8.0	200	192.5	-	30	44	924
34700.W1695	Stainless Steel	Pad and Bolt	M24	60	45	9.5	100	91.0	-	36	52	935
34700.W1698	Stainless Steel	Pad and Bolt	M24	60	45	9.5	200	191.0	-	36	52	1231

LEVELLING FEET



34701

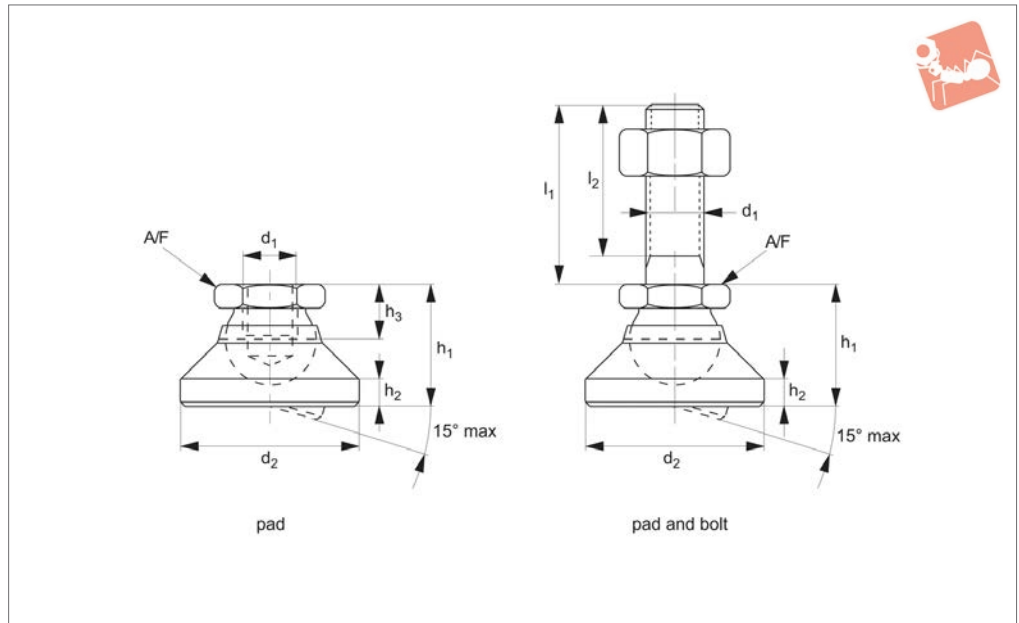

Material

Steel type-

Pad: heat-treated, C35Pbk (ETG100) tempered (800-1000 N/mm²), blackened.

Ball: free cutting steel, 11SMnPn30k (1.0718) - ball hardened (550±50HV10), blackened.

Ball with bolt: heat-treated steel, blackened.

Lock nut: Steel blackened, DIN 934/ISO 4032.

Stainless type-

Pad: stainless steel 1.4305 (AISI 303).

Ball: stainless steel 1.4305 (AISI 303).

Ball with bolt: stainless steel 1.4305 (AISI 303).

Lock nut: Stainless steel A2, DIN 934/ISO 4032.

Tips

To be used as feet and thrust pads.

Order No.	Material	Type	d ₁	d ₂	h ₁ ≈	h ₂	h ₃	l ₁	l ₂	A/F	Static load steel kN max.	Static load stainless kN max.	Weight g
34701.W0006	Steel	Pad	M6	20	14	2.5	5.0	-	-	10	10	8	15
34701.W0008	Steel	Pad	M8	25	18	4.0	7.0	-	-	13	18	14	33
34701.W0010	Steel	Pad	M10	32	22	5.0	9.0	-	-	17	20	16	66
34701.W0012	Steel	Pad	M12	40	26	6.0	11.0	-	-	19	35	28	112
34701.W0016	Steel	Pad	M16	50	32	7.0	13.5	-	-	24	45	36	220
34701.W0020	Steel	Pad	M20	60	42	8.0	17.0	-	-	30	55	44	413
34701.W0024	Steel	Pad	M24	60	45	9.5	19.0	-	-	36	65	52	462
34701.W0206	Stainless	Pad	M6	20	14	2.5	5.0	-	-	10	10	8	15
34701.W0208	Stainless	Pad	M8	25	18	4.0	7.0	-	-	13	18	14	33
34701.W0210	Stainless	Pad	M10	32	22	5.0	9.0	-	-	17	20	16	66
34701.W0212	Stainless	Pad	M12	40	26	6.0	11.0	-	-	19	35	28	112
34701.W0216	Stainless	Pad	M16	50	32	7.0	13.5	-	-	24	45	36	220
34701.W0220	Stainless	Pad	M20	60	42	8.0	17.0	-	-	30	55	44	413
34701.W0224	Stainless	Pad	M24	60	45	9.5	19.0	-	-	36	65	52	462
34701.W0410	Steel	Pad and Bolt	M 6	20	14	2.5	-	60	57.0	10	10	8	29
34701.W0422	Steel	Pad and Bolt	M 8	25	18	4.0	-	80	76.0	13	18	14	66
34701.W0438	Steel	Pad and Bolt	M10	32	22	5.0	-	100	95.5	17	20	16	133
34701.W0442	Steel	Pad and Bolt	M10	32	22	5.0	-	150	145.5	17	20	16	159
34701.W0452	Steel	Pad and Bolt	M12	40	26	6.0	-	100	94.5	19	35	28	211
34701.W0456	Steel	Pad and Bolt	M12	40	26	6.0	-	150	144.5	19	35	28	247
34701.W0468	Steel	Pad and Bolt	M16	50	32	7.0	-	100	94.0	24	45	36	407
34701.W0472	Steel	Pad and Bolt	M16	50	32	7.0	-	200	194.0	24	45	36	540
34701.W0482	Steel	Pad and Bolt	M20	60	42	8.0	-	100	92.5	30	55	44	722
34701.W0488	Steel	Pad and Bolt	M20	60	42	8.0	-	200	192.5	30	55	44	924
34701.W0495	Steel	Pad and Bolt	M24	60	45	9.5	-	100	91.0	36	65	52	935
34701.W0498	Steel	Pad and Bolt	M24	60	45	9.5	-	200	191.0	36	65	52	1231
34701.W0610	Stainless	Pad and Bolt	M 6	20	14	2.5	-	60	57.0	10	10	8	29
34701.W0622	Stainless	Pad and Bolt	M 8	25	18	4.0	-	80	76.0	13	18	14	66
34701.W0638	Stainless	Pad and Bolt	M10	32	22	5.0	-	100	95.5	17	20	16	133
34701.W0642	Stainless	Pad and Bolt	M10	32	22	5.0	-	150	145.5	17	20	16	159



Levelling Feet

pad and bolt steel or stainless



Levelling Feet

Order No.	Material	Type	d ₁	d ₂	h ₁ ≈	h ₂	h ₃	l ₁	l ₂	A/F	Static load steel kN max.	Static load stainless kN max.	Weight g
34701.W0652	Stainless	Pad and Bolt	M12	40	26	6.0	-	100	94.5	19	35	28	211
34701.W0656	Stainless	Pad and Bolt	M12	40	26	6.0	-	150	144.5	19	35	28	247
34701.W0668	Stainless	Pad and Bolt	M16	50	32	7.0	-	100	94.0	24	45	36	407
34701.W0672	Stainless	Pad and Bolt	M16	50	32	7.0	-	200	194.0	24	45	36	540
34701.W0682	Stainless	Pad and Bolt	M20	60	42	8.0	-	100	92.5	30	55	44	722
34701.W0688	Stainless	Pad and Bolt	M20	60	42	8.0	-	200	192.5	30	55	44	924
34701.W0695	Stainless	Pad and Bolt	M24	60	45	9.5	-	100	91.0	36	65	52	935
34701.W0698	Stainless	Pad and Bolt	M24	60	45	9.5	-	200	191.0	36	65	52	1231

LEVELLING FEET



34711

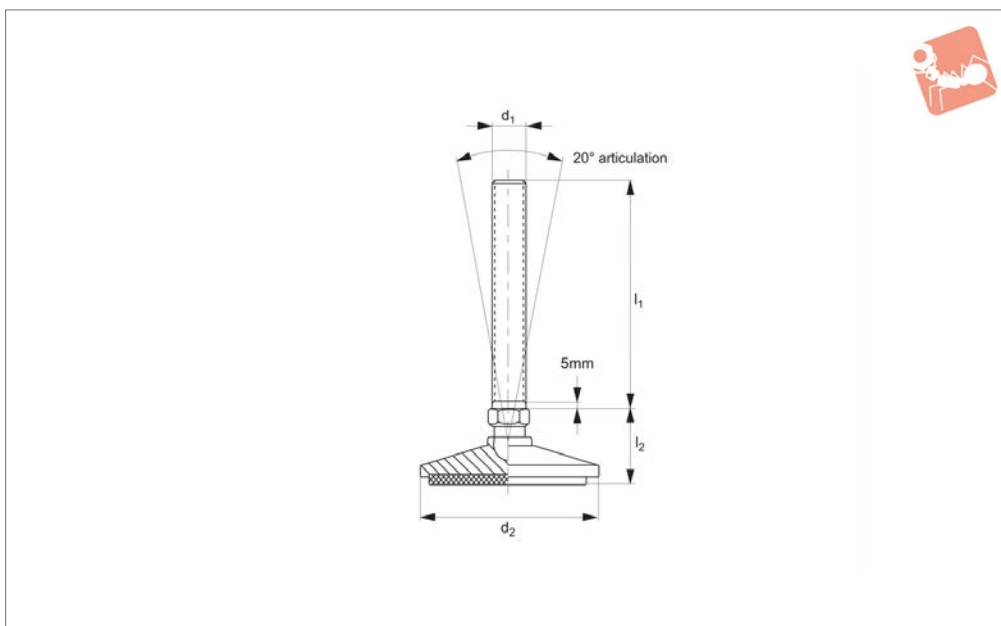

Material

Pad and bolt: stainless steel, type AISI 303. With nitril rubber pad.

Tips

For use in a wide range of industries including, food processing, pharmaceutical,

electronic, medical and machinery shops.

Order No.	d ₁	l ₁	d ₂	l ₂	Static load kN max.
34711.W0120	M12	75	55	27	7.5
34711.W0121	M12	125	55	27	7.5
34711.W0122	M12	150	55	27	7.5
34711.W0160	M16	75	65	33	12.5
34711.W0161	M16	125	65	33	12.5
34711.W0162	M16	150	65	33	12.5
34711.W0200	M20	125	75	41	17.5
34711.W0201	M20	150	75	41	17.5
34711.W0202	M20	200	75	41	17.5
34711.W0240	M24	125	100	52	25.0
34711.W0241	M24	150	100	52	25.0
34711.W0242	M24	200	100	52	25.0

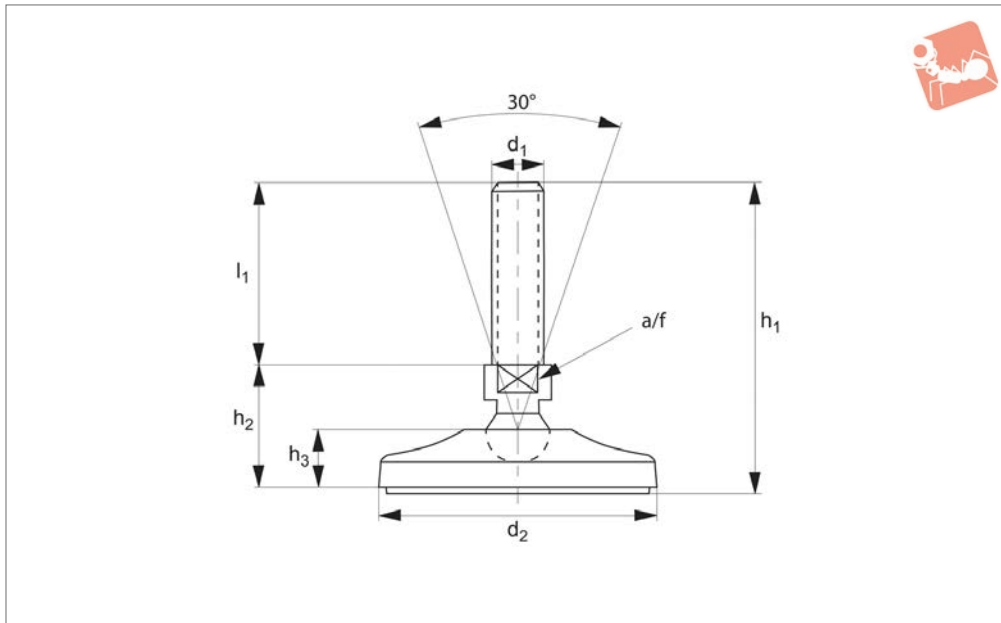

34714

LEVELLING FEET

Material

Stainless steel (AISI 304), with rubber pad (70 Shore A).

Stainless steel (AISI 316) version available

on request.

Technical Notes

Load values refer to static loads, located at

half the screw height.

When vibrations or dynamic loads are present these values should be reduced.

Order No.	d ₁	l ₁	d ₂	h ₁	h ₂	h ₃	A/F	Load kN max.
34714.W1000	M10	25	50	56	28	16.0	14	15
34714.W1001	M10	50	50	81	28	16.0	14	15
34714.W1002	M10	75	50	106	28	16.0	14	15
34714.W1003	M10	100	50	131	28	16.0	14	15
34714.W1004	M10	125	50	156	28	16.0	14	15
34714.W1200	M12	25	50	56	28	16.0	14	15
34714.W1201	M12	50	50	81	28	16.0	14	15
34714.W1202	M12	75	50	106	28	16.0	14	15
34714.W1203	M12	100	50	131	28	16.0	14	15
34714.W1204	M12	125	50	156	28	16.0	14	15
34714.W1400	M14	50	65	83	30	17.0	14	20
34714.W1401	M14	75	65	108	30	17.0	14	20
34714.W1402	M14	100	65	133	30	17.0	14	20
34714.W1403	M14	125	65	158	30	17.0	14	20
34714.W1404	M14	150	65	183	30	17.0	14	20
34714.W1600	M16	50	100	96	43	20.0	20	35
34714.W1601	M16	75	100	121	43	20.0	20	35
34714.W1602	M16	100	100	146	43	20.0	20	35
34714.W1603	M16	125	100	171	43	20.0	20	35
34714.W1604	M16	150	100	196	43	20.0	20	35
34714.W1605	M16	175	100	221	43	20.0	20	35
34714.W1606	M16	200	100	246	43	20.0	20	35
34714.W2000	M20	75	100	121	43	20.0	20	45
34714.W2001	M20	100	100	146	43	20.0	20	45
34714.W2002	M20	125	100	171	43	20.0	20	45
34714.W2003	M20	150	100	196	43	20.0	20	45
34714.W2004	M20	175	100	221	43	20.0	20	45
34714.W2005	M20	200	100	246	43	20.0	20	45
34714.W2006	M20	225	100	271	43	20.0	20	45
34714.W2007	M20	250	100	296	43	20.0	20	45
34714.W2400	M24	75	100	122	44	20.0	20	55
34714.W2401	M24	100	100	147	44	20.0	20	55
34714.W2402	M24	125	100	172	44	20.0	20	55



Order No.	d ₁	l ₁	d ₂	h ₁	h ₂	h ₃	A/F	Load kN max.
34714.W2403	M24	150	100	202	44	20.0	20	55
34714.W2404	M24	175	100	222	44	20.0	20	55
34714.W2405	M24	200	100	247	44	20.0	20	55
34714.W2406	M24	225	100	272	44	20.0	20	55
34714.W2407	M24	250	100	297	44	20.0	20	55
34714.W3000	M30	100	120	150	47	23.0	26	65
34714.W3001	M30	125	120	175	47	23.0	26	65
34714.W3002	M30	150	120	200	47	23.0	26	65
34714.W3003	M30	175	120	225	47	23.0	26	65
34714.W3004	M30	200	120	250	47	23.0	26	65
34714.W3005	M30	225	120	275	47	23.0	26	65
34714.W3006	M30	250	120	300	47	23.0	26	65



Levelling Feet

stainless steel, heavy duty



Levelling Feet

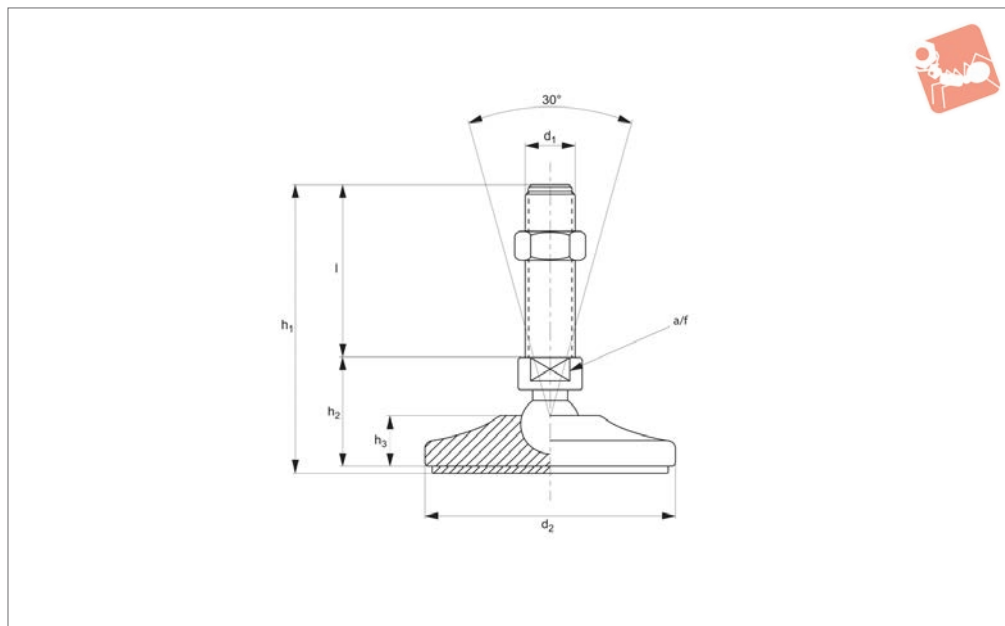

34716

LEVELLING FEET

Material

Stainless steel (AISI 304), with rubber pad (70 Shore A).

Stainless steel (AISI 316) version available

on request.

Technical Notes

Load values refer to static loads, located at

half the screw height.

When vibrations or dynamic loads are present these values should be reduced.

Order No.	d ₁	d ₂	l	h ₁	h ₂	h ₃	A/F	Load kN max.
34716.W2000	M20	160	75	127	49	26	20	50
34716.W2001	M20	160	100	152	49	26	20	50
34716.W2002	M20	160	125	177	49	26	20	50
34716.W2003	M20	160	150	202	49	26	20	50
34716.W2004	M20	160	175	227	49	26	20	50
34716.W2005	M20	160	200	252	49	26	20	50
34716.W2400	M24	160	75	127	49	26	20	60
34716.W2401	M24	160	100	152	49	26	20	60
34716.W2402	M24	160	125	177	49	26	20	60
34716.W2403	M24	160	150	202	49	26	20	60
34716.W2404	M24	160	175	227	49	26	20	60
34716.W2405	M24	160	200	252	49	26	20	60
34716.W3000	M30	160	100	152	49	26	26	70
34716.W3001	M30	160	125	177	49	26	26	70
34716.W3002	M30	160	150	202	49	26	26	70
34716.W3003	M30	160	175	227	49	26	26	70
34716.W3004	M30	160	200	252	49	26	26	70
34716.W3005	M30	160	225	277	49	26	26	70
34716.W3006	M30	160	250	302	49	26	26	70
34716.W3600	M36	160	150	204	51	26	32	80
34716.W3601	M36	160	200	254	51	26	32	80



34712

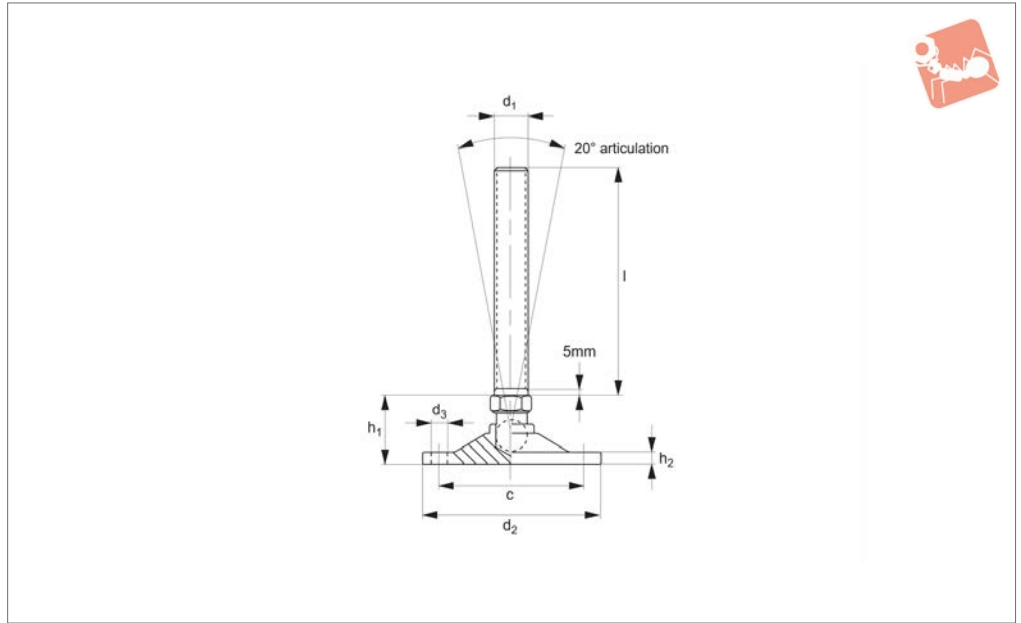

Material

Pad and bolt: stainless steel, AISI 303.

Technical Notes

Bolt has a 20° angle of movement.

Order No.	d ₁	d ₂	c	d ₃	l	h ₁	h ₂	Static load kN max.
34712.W0508	M 8	50	40	5.5	60	22	4.0	3.0
34712.W0600	M10	50	40	5.5	75	22	5.0	5.0
34712.W0620	M12	50	40	5.5	75	25	4.0	7.5
34712.W0621	M12	60	50	5.5	75	25	5.0	12.5
34712.W0622	M12	60	50	5.5	125	25	5.0	12.5
34712.W0623	M12	60	50	5.5	150	25	5.0	12.5
34712.W0660	M16	80	68	6.5	75	31	6.0	17.5
34712.W0661	M16	80	68	6.5	125	31	6.0	17.5
34712.W0662	M16	80	68	6.5	150	31	6.0	17.5
34712.W0700	M20	100	82	9.0	125	39	6.5	25.0
34712.W0701	M20	100	82	9.0	150	39	6.5	25.0
34712.W0702	M20	100	82	9.0	200	39	6.5	25.0
34712.W0703	M24	120	100	11.0	150	56	7.5	37.5
34712.W0704	M24	120	100	11.0	200	56	7.5	37.5



Levelling Feet - Bolt Down, Heavy

pad and bolt **stainless steel**

Levelling Feet

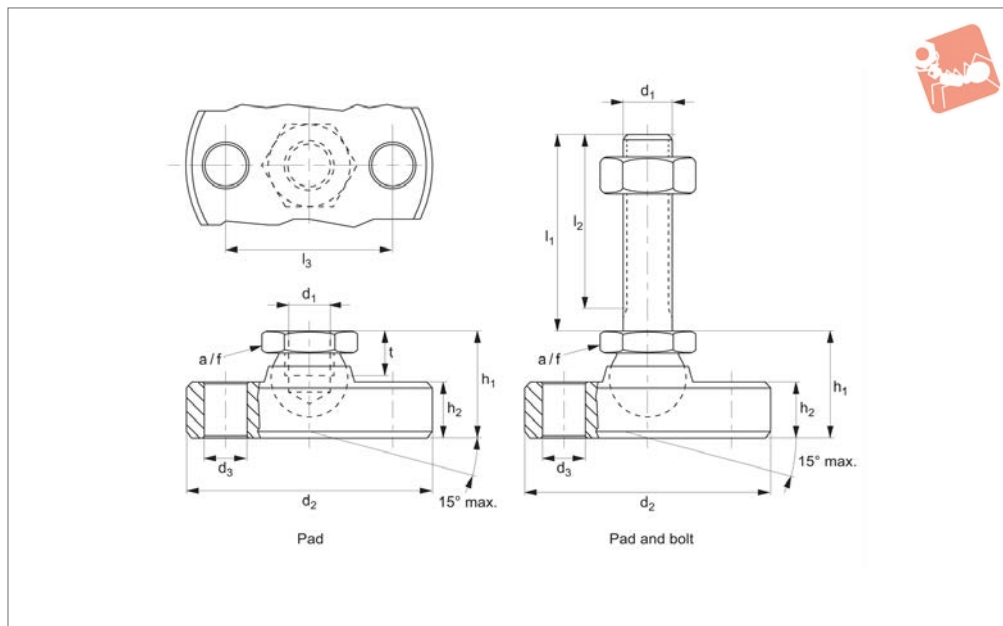

34713

LEVELLING FEET

Material

Pad and bolt: stainless steel 1.4305, AISI 303.

Lock nut: Stainless steel A2, DIN 934 and

ISO 4032.

Technical Notes

To be used as foot and thrust pad. Inclu-

ding two mounting holes in pad.

Order No.	Finish	d ₁	l ₁	d ₂ -0.5	d ₃	l ₂	l ₃	h ₁ ≈	h ₂	t	A/F	Static load kN max.	Weight g
34713.W0706	Pad	M 6	-	45	6.6	-	32	14	6.5	5.0	10	8	79
34713.W0708	Pad	M 8	-	50	6.6	-	38	18	8.5	7.0	13	14	130
34713.W0710	Pad	M10	-	60	9.0	-	44	22	11.5	9.0	17	16	250
34713.W0712	Pad	M12	-	65	9.0	-	48	26	12.5	11.0	19	28	326
34713.W0716	Pad	M16	-	70	9.0	-	54	32	13.5	13.5	24	36	427
34713.W0720	Pad	M20	-	80	9.0	-	64	42	16.5	17.0	30	44	718
34713.W0724	Pad	M24	-	100	11.0	-	78	45	20.5	19.0	36	52	1304
34713.W0810	Pad and Bolt	M 6	60	45	6.6	57.0	32	14	6.5	-	10	8	93
34713.W0822	Pad and Bolt	M 8	80	50	6.6	76.0	38	18	8.5	-	13	14	163
34713.W0838	Pad and Bolt	M10	100	60	9.0	95.5	44	22	11.5	-	17	16	318
34713.W0842	Pad and Bolt	M10	150	60	9.0	145.5	44	22	11.5	-	17	16	341
34713.W0852	Pad and Bolt	M12	100	65	9.0	94.5	48	26	12.5	-	19	28	423
34713.W0856	Pad and Bolt	M12	150	65	9.0	144.5	48	26	12.5	-	19	28	459
34713.W0868	Pad and Bolt	M16	100	70	9.0	94.0	54	32	13.5	-	24	36	615
34713.W0872	Pad and Bolt	M16	200	70	9.0	194.0	54	32	13.5	-	24	36	746
34713.W0882	Pad and Bolt	M20	100	80	9.0	92.5	64	42	16.5	-	30	44	1029
34713.W0888	Pad and Bolt	M20	200	80	9.0	192.5	64	42	16.5	-	30	44	1231
34713.W0895	Pad and Bolt	M24	100	100	11.0	91.0	78	45	20.5	-	36	52	1775
34713.W0898	Pad and Bolt	M24	200	100	11.0	191.0	78	45	20.5	-	36	52	2075



LEVELLING FEET

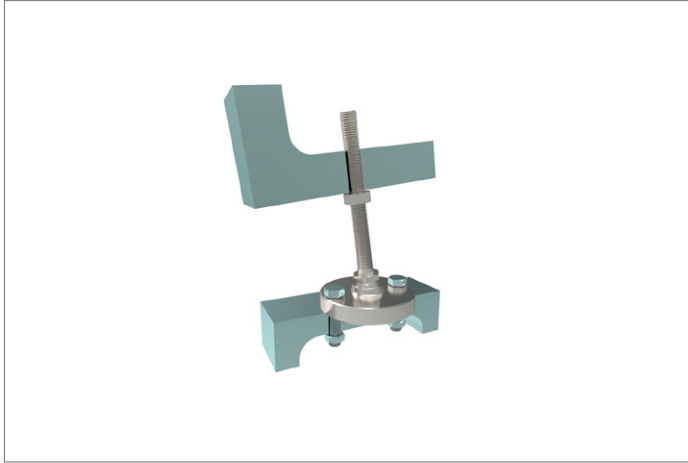



Levelling Feet - Bolt Down

stainless steel, heavy duty

Levelling Feet

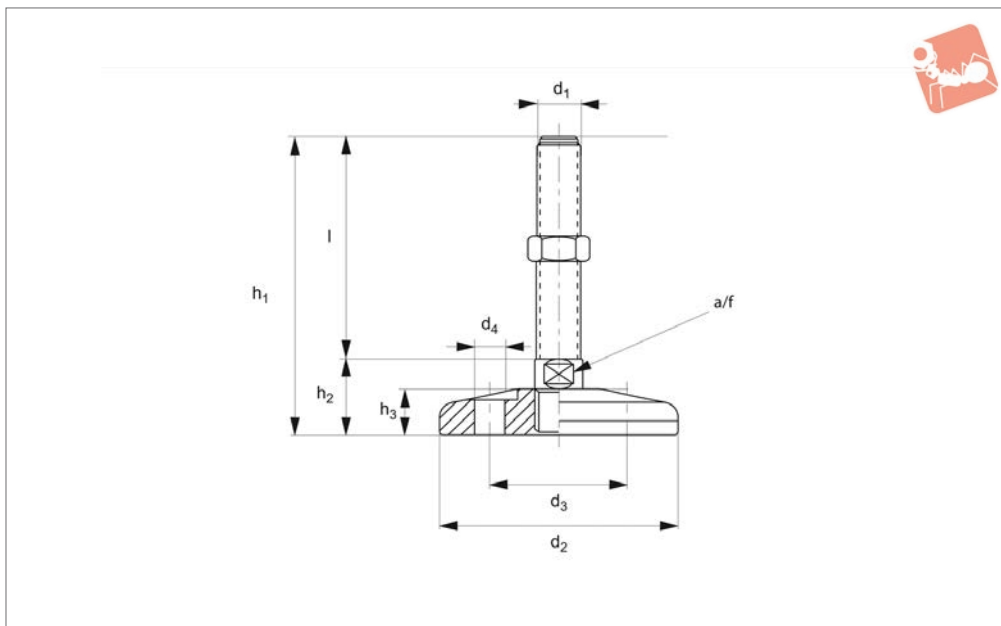

34718

LEVELLING FEET

Material

Stainless steel (AISI 304).
Stainless steel (AISI 316) version available on request.

Technical Notes

Load values refer to static loads, located at half the screw height.
When vibrations or dynamic loads are

present these values should be reduced.

Order No.	d ₁	d ₂	d ₃	d ₄	l	h ₁	h ₂	h ₃	A/F	Load kN max.
34718.W1600	M16	100	74	12.5	100	133	33	20	20	35
34718.W1601	M16	100	74	12.5	150	183	33	20	20	35
34718.W1602	M16	100	74	12.5	200	233	33	20	20	35
34718.W2000	M20	100	74	12.5	100	133	33	20	20	40
34718.W2001	M20	100	74	12.5	150	183	33	20	20	40
34718.W2002	M20	100	74	12.5	200	233	33	20	20	40
34718.W2003	M20	100	74	12.5	250	283	33	20	20	40
34718.W2400	M24	100	74	12.5	100	134	34	20	20	45
34718.W2401	M24	100	74	12.5	150	184	34	20	20	45
34718.W2402	M24	100	74	12.5	200	234	34	20	20	45
34718.W2403	M24	100	74	12.5	250	284	34	20	20	45
34718.W2004	M20	120	74	12.5	100	135	35	22	20	45
34718.W2005	M20	120	74	12.5	150	185	35	22	20	45
34718.W2006	M20	120	74	12.5	200	235	35	22	20	45
34718.W2007	M20	120	74	12.5	250	285	35	22	20	45
34718.W2404	M24	120	74	12.5	100	136	36	22	20	50
34718.W2405	M24	120	74	12.5	150	186	36	22	20	50
34718.W2406	M24	120	74	12.5	200	231	36	22	20	50
34718.W2407	M24	120	74	12.5	250	281	36	22	20	50
34718.W3000	M30	120	74	12.5	100	136	36	22	26	60
34718.W3001	M30	120	74	12.5	150	186	36	22	26	60
34718.W3002	M30	120	74	12.5	200	236	36	22	26	60
34718.W3003	M30	120	74	12.5	250	286	36	22	26	60
34718.W2008	M20	159	74	12.5	100	136	36	23	20	50
34718.W2009	M20	159	74	12.5	150	186	36	23	20	50
34718.W2010	M20	159	74	12.5	200	236	36	23	20	50
34718.W2011	M20	159	74	12.5	250	286	36	23	20	50
34718.W2408	M24	159	74	12.5	100	137	37	23	20	60
34718.W2409	M24	159	74	12.5	150	187	37	23	20	60
34718.W2410	M24	159	74	12.5	200	237	37	23	20	60
34718.W2411	M24	159	74	12.5	250	287	37	23	20	60
34718.W3004	M30	159	74	12.5	100	137	37	23	26	70
34718.W3005	M30	159	74	12.5	150	187	37	23	26	70



Order No.	d ₁	d ₂	d ₃	d ₄	l	h ₁	h ₂	h ₃	A/F	Load kN max.
34718.W3006	M30	159	74	12.5	200	237	37	23	26	70
34718.W3007	M30	159	74	12.5	250	287	37	23	26	70

LEVELLING FEET



Levelling Feet - Bolt Down

stainless steel, medium load

Levelling Feet

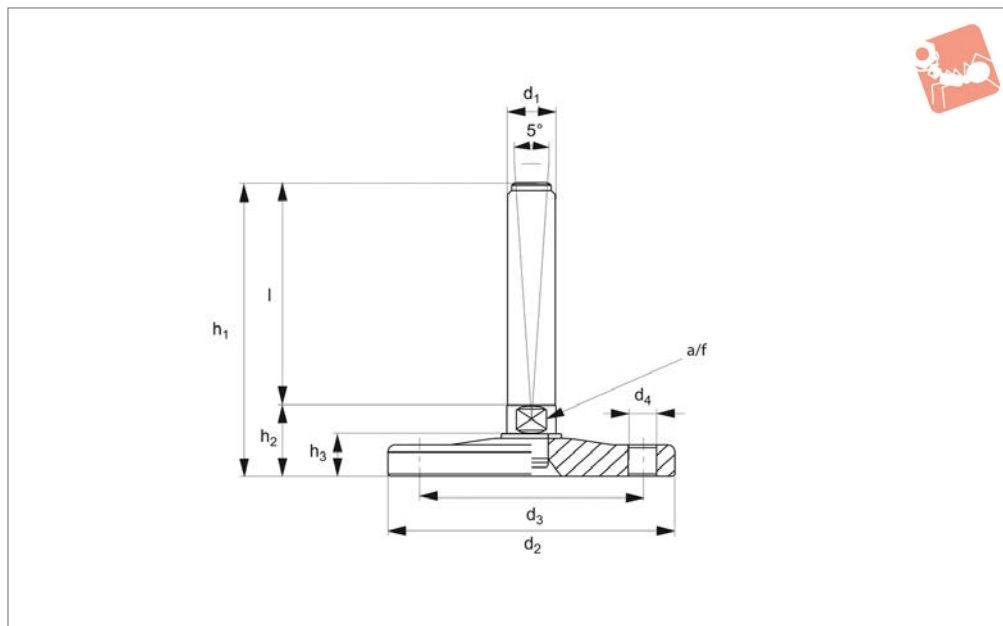

34717

LEVELLING FEET

Material

Stainless steel (AISI 304).
Stainless steel (AISI 316) version available on request.

Technical Notes

Load values refer to static loads, located at half the screw height.
When vibrations or dynamic loads are

present these values should be reduced.

Order No.	d ₁	d ₂	d ₃	d ₄	l	h ₁	h ₂	h ₃	A/F	Load kN max.
34717.W1400	M14	80	62	10.5	50	70	20	11.5	14	20
34717.W1401	M14	80	62	10.5	100	120	20	11.5	14	20
34717.W1402	M14	80	62	10.5	150	170	20	11.5	14	20
34717.W1600	M16	120	62	12.5	75	104	29	16.5	17	40
34717.W1601	M16	120	62	12.5	100	129	29	16.5	17	40
34717.W1602	M16	120	62	12.5	150	179	29	16.5	17	40
34717.W2000	M20	120	62	12.5	75	104	29	16.5	17	40
34717.W2001	M20	120	62	12.5	125	154	29	16.5	17	40
34717.W2002	M20	120	62	12.5	175	204	29	16.5	17	40
34717.W2400	M24	120	62	12.5	100	130	30	16.5	20	45
34717.W2401	M24	120	62	12.5	150	180	30	16.5	20	45
34717.W2402	M24	120	62	12.5	200	230	30	16.5	20	45
34717.W3000	M30	120	62	12.5	125	155	30	16.5	26	45
34717.W3001	M30	120	62	12.5	175	205	30	16.5	26	45
34717.W3002	M30	120	62	12.5	225	255	30	16.5	26	45
34717.W2003	M20	150	62	12.5	75	104	29	16.5	17	50
34717.W2004	M20	150	62	12.5	125	154	29	16.5	17	50
34717.W2005	M20	150	62	12.5	175	204	29	16.5	17	50
34717.W2403	M24	150	62	12.5	100	130	30	16.5	20	55
34717.W2404	M24	150	62	12.5	150	180	30	16.5	20	55
34717.W2405	M24	150	62	12.5	200	230	30	16.5	20	55



34611

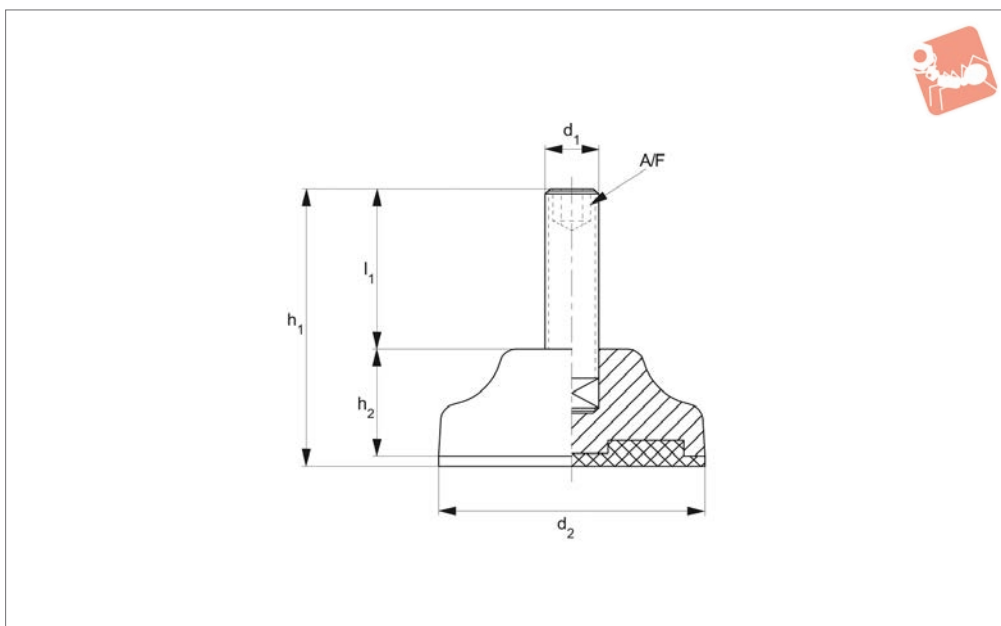

Material

Pad: polyamide reinforced by fibre glass with anti-slip pad.
Bolt: steel (C40)

Technical Notes

Load values refer to static loads, located at half the screw height.
When vibrations or dynamic loads are

present these values should be reduced.

Order No.	d_1	d_2	l	h_1	h_2	A/F	Load kN max.
34611.W0800	M 8	40	25	44	19	4	5
34611.W0801	M 8	40	50	69	19	4	5
34611.W0802	M 8	50	25	48	23	4	6
34611.W0803	M 8	50	50	73	23	4	6
34611.W1000	M10	40	25	44	19	5	5
34611.W1001	M10	40	50	69	19	5	5
34611.W1002	M10	50	25	48	23	5	6
34611.W1003	M10	50	50	73	23	5	6



Levelling Feet

pad plastic, bolt steel



Levelling Feet

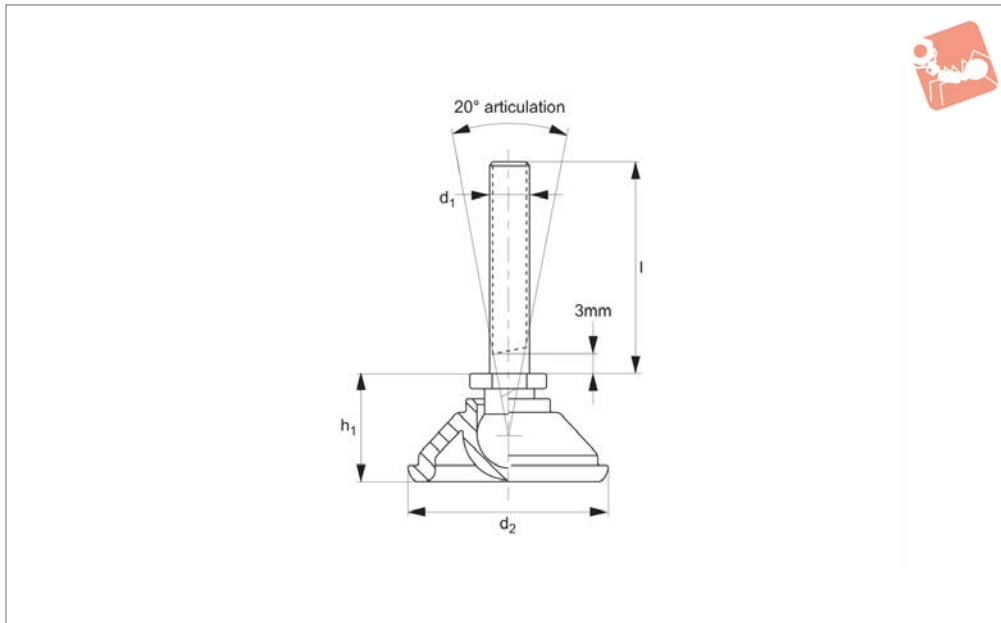

34721

LEVELLING FEET

Material

Pad: polyamide reinforced nylon.

Bolt: mild steel, plated.

Order No.	d ₁	d ₂	l	h ₁	Static load kN max.
34721.W0060	M 6	40	20	21	3.0
34721.W0061	M 6	50	20	23	3.0
34721.W0062	M 6	40	40	21	3.0
34721.W0063	M 6	50	40	23	3.0
34721.W0080	M 8	40	25	21	4.5
34721.W0081	M 8	50	25	23	4.5
34721.W0082	M 8	40	40	21	4.5
34721.W0083	M 8	50	40	23	4.5
34721.W0084	M 8	40	60	21	4.5
34721.W0085	M 8	50	60	23	4.5
34721.W0100	M10	40	38	21	5.0
34721.W0101	M10	50	38	23	5.0
34721.W0102	M10	40	60	21	5.0
34721.W0103	M10	50	60	23	5.0
34721.W0104	M10	40	75	21	5.0
34721.W0105	M10	50	75	23	5.0
34721.W0120	M12	40	50	23	6.0
34721.W0121	M12	50	50	25	6.0
34721.W0122	M12	40	75	23	6.0
34721.W0123	M12	50	75	25	6.0
34721.W0124	M12	40	100	23	6.0
34721.W0125	M12	50	100	25	6.0
34721.W0126	M12	40	125	23	6.0
34721.W0127	M12	50	125	25	6.0



34723

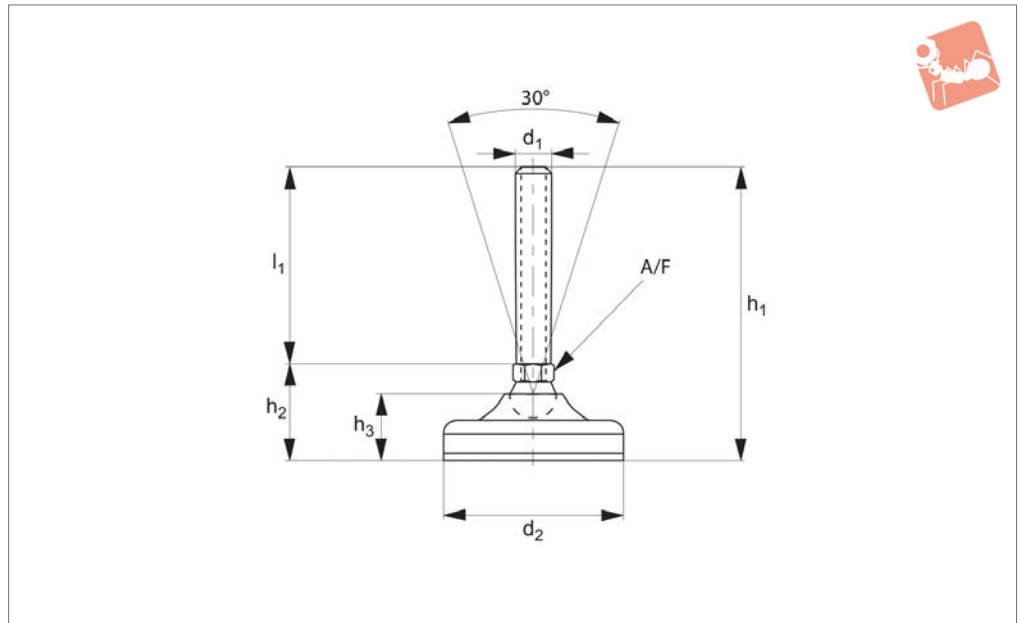

LEVELLING FEET

Material

Pad: polyamide reinforced by fibre glass with anti-slip pad.
Bolt: galvanized steel (C40)

Technical Notes

Load values refer to static loads, located at half the screw height.
When vibrations or dynamic loads are

present these values should be reduced.

Order No.	d ₁	d ₂	h ₁	h ₂	h ₃	l ₁	A/F	Load kN max.
34723.W0801	M 8	40	55	30	19.5	25	12	10
34723.W0802	M 8	40	80	30	19.5	50	12	10
34723.W0803	M 8	40	105	30	19.5	75	12	10
34723.W0804	M 8	40	130	30	19.5	100	12	10
34723.W1000	M10	65	86	36	26.0	50	14	11
34723.W1001	M10	65	111	36	26.0	75	14	11
34723.W1002	M10	65	136	36	26.0	100	14	11
34723.W1003	M10	65	161	36	26.0	125	14	11
34723.W1200	M12	65	86	36	26.0	50	14	11
34723.W1201	M12	65	111	36	26.0	75	14	11
34723.W1202	M12	65	136	36	26.0	100	14	11
34723.W1203	M12	65	161	36	26.0	125	14	11
34723.W1400	M14	65	86	36	26.0	50	14	15
34723.W1401	M14	65	111	36	26.0	75	14	15
34723.W1402	M14	65	136	36	26.0	100	14	15
34723.W1403	M14	65	161	36	26.0	125	14	15
34723.W1404	M14	65	186	36	26.0	150	14	15
34723.W1405	M14	65	211	36	26.0	175	14	15
34723.W1600	M16	65	86	36	26.0	50	16	15
34723.W1601	M16	65	111	36	26.0	75	16	15
34723.W1602	M16	65	136	36	26.0	100	16	15
34723.W1603	M16	65	161	36	26.0	125	16	15
34723.W1604	M16	65	186	36	26.0	150	16@	15
34723.W1605	M16	65	211	36	26.0	175	16@	15
34723.W1606	M16	65	236	36	26.0	200	16@	15
34723.W2000	M20	65	115	40	26.0	75	17	15
34723.W2001	M20	65	140	40	26.0	100	17	15
34723.W2002	M20	65	165	40	26.0	125	17	15
34723.W2003	M20	65	190	40	26.0	150	17	15
34723.W2004	M20	65	215	40	26.0	175	17	15
34723.W2005	M20	65	240	40	26.0	200	17	15



Levelling Feet - Heavy Duty

bolt down option, bolt steel

Levelling Feet

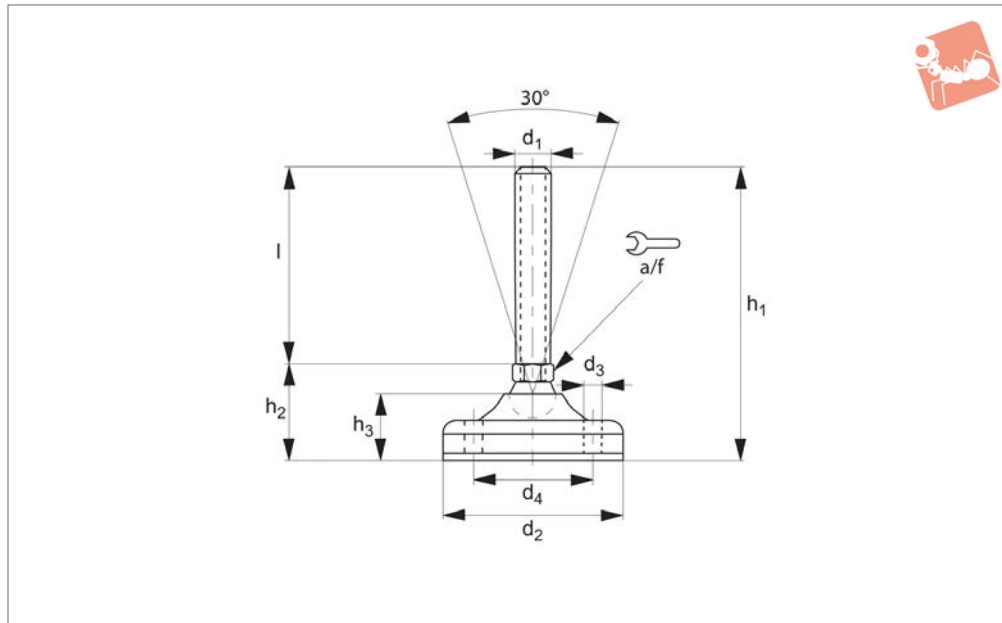

34726

LEVELLING FEET

Material

Pad: polyamide reinforced by fibre glass with anti-slip pad.
Bolt: steel (C40)

Technical Notes

Load values refer to static loads, located at half the screw height.
When vibrations or dynamic loads are

present these values should be reduced.

Order No.	d ₁	d ₂	d ₃	d ₄	l	h ₁	h ₂	h ₃	A/F	Load kN max.
34726.W1600	M16	123	12.5	73	50	110	60	40	20	35
34726.W1601	M16	123	12.5	73	75	135	60	40@	20	35
34726.W1602	M16	123	12.5	73	100	160	60	40	20	35
34726.W1603	M16	123	12.5	73	125	185	60	40@	20	35
34726.W1604	M16	123	12.5	73	150	210	60	40	20	35
34726.W1605	M16	123	12.5	73	175	235	60	40	20	35
34726.W1606	M16	123	12.5	73	200	260	60	40	20	35
34726.W1607	M16	123	12.5	73	225	288	60	40	20	35
34726.W2000	M20	123	12.5	73	75	135	60	40	20	35
34726.W2001	M20	123	12.5	73	100	160	60	40	20	35
34726.W2002	M20	123	12.5	73	125	185	60	40	20	35
34726.W2003	M20	123	12.5	73	150	210	60	40	20	35
34726.W2004	M20	123	12.5	73	175	235	60	40	20	35
34726.W2005	M20	123	12.5	73	200	260	60	40	20	35
34726.W2006	M20	123	12.5	73	225	285	60	40	20	35
34726.W2007	M20	123	12.5	73	250	310	60	40	20	35
34726.W2400	M24	123	12.5	73	75	135	60	40	20	35
34726.W2401	M24	123	12.5	73	100	160	60	40	20	35
34726.W2402	M24	123	12.5	73	125	185	60	40	20	35
34726.W2403	M24	123	12.5	73	150	210	60	40	20	35
34726.W2404	M24	123	12.5	73	175	235	60	40	20	35
34726.W2405	M24	123	12.5	73	200	260	60	40	20	35
34726.W2406	M24	123	12.5	73	225	285	60	40	20	35
34726.W2407	M24	123	12.5	73	250	310	60	40	20	35
34726.W3000	M30	123	12.5	73	100	161	60	40	20	35
34726.W3001	M30	123	12.5	73	125	186	60	40	20	35
34726.W3002	M30	123	12.5	73	150	211	60	40	20	35
34726.W3003	M30	123	12.5	73	175	236	60	40	20	35
34726.W3004	M30	123	12.5	73	200	261	60	40	20	35
34726.W3005	M30	123	12.5	73	225	286	60	40	20	35
34726.W3006	M30	123	12.5	73	250	311	60	40	20	35



34724

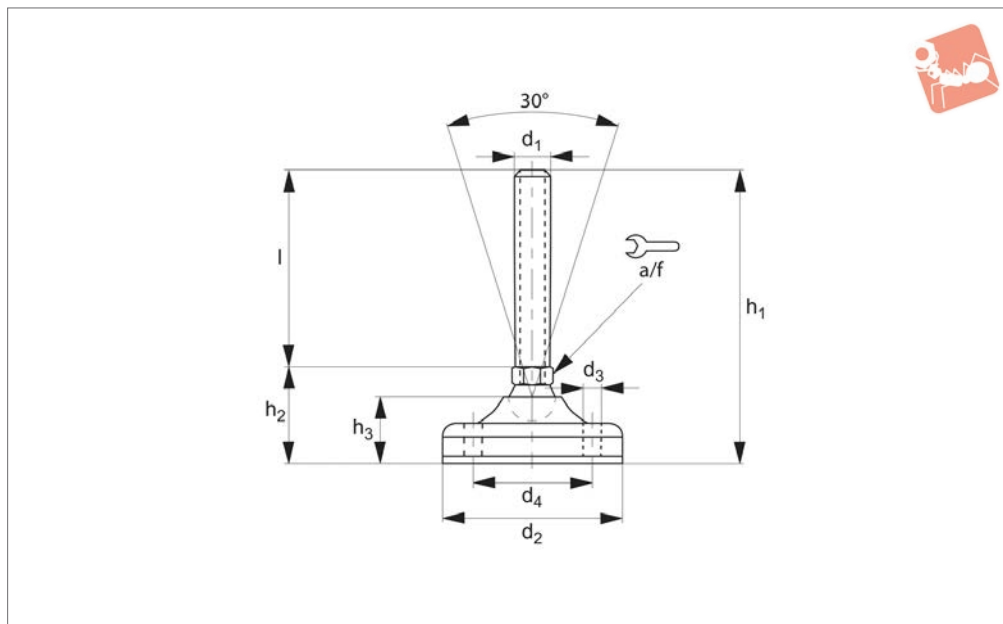

Material

Pad: polyamide reinforced by fibre glass with anti-slip pad.
Bolt: steel (C40)

Technical Notes

Load values refer to static loads, located at half the screw height.
When vibrations or dynamic loads are

present these values should be reduced.

Order No.	d ₁	d ₂	d ₃	d ₄	l	h ₁	h ₂	h ₃	A/F	Load kN max.
34724.W1000	M10	83	8.5	55	50	91	41	30	14	15
34724.W1001	M10	83	8.5	55	75	116	41	30	14	15
34724.W1002	M10	83	8.5	55	100	141	41	30	14	15
34724.W1003	M10	83	8.5	55	125	166	41	30	14	15
34724.W1200	M12	83	8.5	55	50	91	41	30	14	15
34724.W1201	M12	83	8.5	55	75	116	41	30	14	15
34724.W1202	M12	83	8.5	55	100	141	41	30	14	15
34724.W1203	M12	83	8.5	55	125	161	41	30	14	15
34724.W1400	M14	83	8.5	55	50	91	41	30	14	20
34724.W1401	M14	83	8.5	55	75	116	41	30	14	20
34724.W1402	M14	83	8.5	55	100	141	41	30	14	20
34724.W1403	M14	83	8.5	55	125	166	41	30	14	20
34724.W1404	M14	83	8.5	55	150	191	41	30	14	20
34724.W1405	M14	83	8.5	55	175	216	41	30	14	20
34724.W1600	M16	83	8.5	55	50	91	41	30	16	20
34724.W1601	M16	83	8.5	55	75	116	41	30	16	20
34724.W1602	M16	83	8.5	55	100	141	41	30	16	20
34724.W1603	M16	83	8.5	55	125	166	41	30	16	20
34724.W1604	M16	83	8.5	55	150	191	41	30	16	20
34724.W1605	M16	83	8.5	55	175	216	41	30	16	20
34724.W1606	M16	83	8.5	55	200	241	41	30	16	20
34724.W1607	M16	103	12.5	73	50	104	54	35@	20	25
34724.W1608	M16	103	12.5	73	75	129	54	35@	20	25
34724.W1609	M16	103	12.5	73	100	154	54	35@	20	25
34724.W1700	M16	103	12.5	73	125	179	54	35@	20	25
34724.W1701	M16	103	12.5	73	150	204	54	35@	20	25
34724.W1702	M16	103	12.5	73	175	229	54	35	20	25
34724.W1703	M16	103	12.5	73	200	254	54	35@	20	25
34724.W1704	M16	103	12.5	73	225	279	54	35@	20	25
34724.W2000	M20	83	8.5	55	75	119	44	30@	17	20
34724.W2001	M20	83	8.5	55	100	144	44	30	17	20
34724.W2002	M20	83	8.5	55	125	169	44	30	17	20
34724.W2003	M20	83	8.5	55	150	194	44	30	17	20

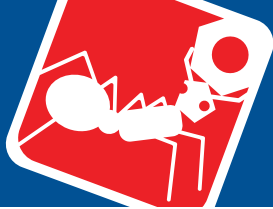

Levelling Feet

plastic pad, bolt steel



Levelling Feet

Order No.	d ₁	d ₂	d ₃	d ₄	l	h ₁	h ₂	h ₃	A/F	Load kN max.
34724.W2004	M20	83	8.5	55	175	219	44	30	17	20
34724.W2005	M20	83	8.5	55	200	244	44	30	17	20
34724.W2006	M20	83	8.5	55	225	269	44	30	17	20
34724.W2007	M20	103	12.5	73	75	129	54	35	20	25
34724.W2008	M20	103	12.5	73	100	154	54	35	20	25
34724.W2009	M20	103	12.5	73	125	179	54	35	20	25
34724.W2010	M20	103	12.5	73	150	204	54	35	20	25
34724.W2011	M20	103	12.5	73	175	229	54	35	20	25
34724.W2012	M20	103	12.5	73	200	254	54	35	20	25
34724.W2013	M20	103	12.5	73	225	279	54	35	20	25
34724.W2014	M20	103	12.5	73	250	304	54	35	20	25
34724.W2400	M24	103	12.5	73	75	129	54	35	20	25
34724.W2401	M24	103	12.5	73	100	154	54	35	20	25
34724.W2402	M24	103	12.5	73	125	179	54	35	20	25
34724.W2403	M24	103	12.5	73	150	204	54	35	20	25
34724.W2404	M24	103	12.5	73	175	229	54	35	20	25
34724.W2405	M24	103	12.5	73	200	254	54	35	20	25
34724.W2406	M24	103	12.5	73	225	279	54	35	20	25
34724.W2407	M24	103	12.5	73	250	304	54	35	20	25

LEVELLING FEET



34722

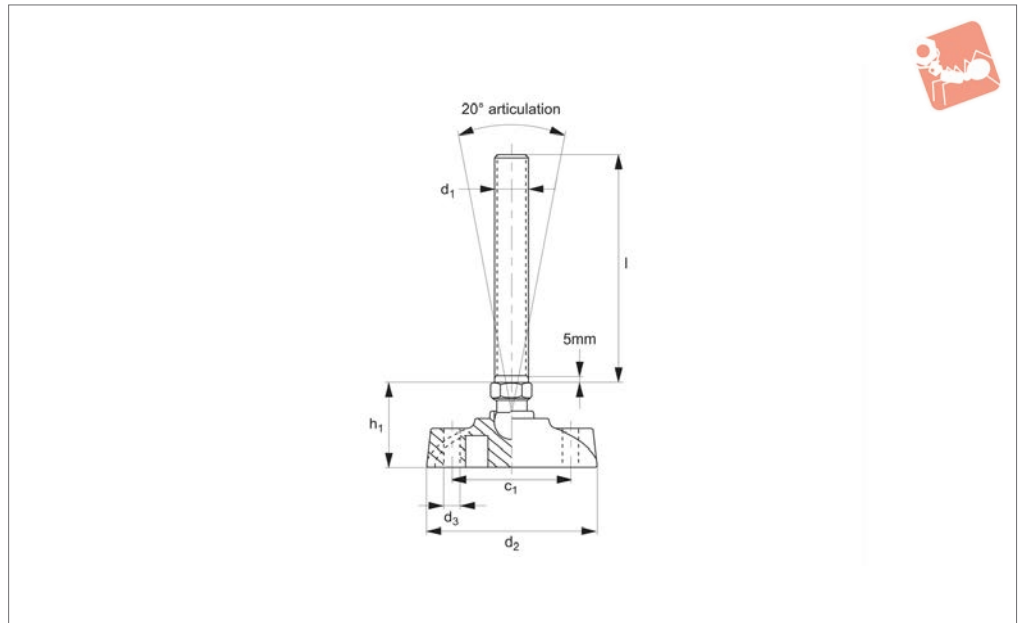

Material

Pad: polyamide reinforced nylon.
Bolt: mild steel, electrolyses nickel plated.

Technical Notes

Supplied with plastic mounting hole plugs, these prevent material and waste entering

the mounting holes, thus simplifying cleaning and maintenance.

Order No.	d ₂	d ₃	l	c ₁	h ₁	Static load kN max.	Thread size d ₁
34722.W0620	100	10.5	75	70	42	10	M12
34722.W0621	100	10.5	125	70	42	10	M12
34722.W0661	100	10.5	125	70	45	20	M16
34722.W0662	100	10.5	150	70	45	20	M16
34722.W0663	100	10.5	200	70	45	20	M16
34722.W0700	100	10.5	125	70	49	20	M20
34722.W0701	100	10.5	150	70	49	20	M20
34722.W0720	100	10.5	125	70	53	20	M24
34722.W0721	100	10.5	150	70	53	20	M24
34722.W0722	100	10.5	200	70	53	20	M24
34722.W0723	100	10.5	250	70	53	20	M24



Levelling Feet - Bolt Down

pad plastic, bolt stainless steel

Levelling Feet

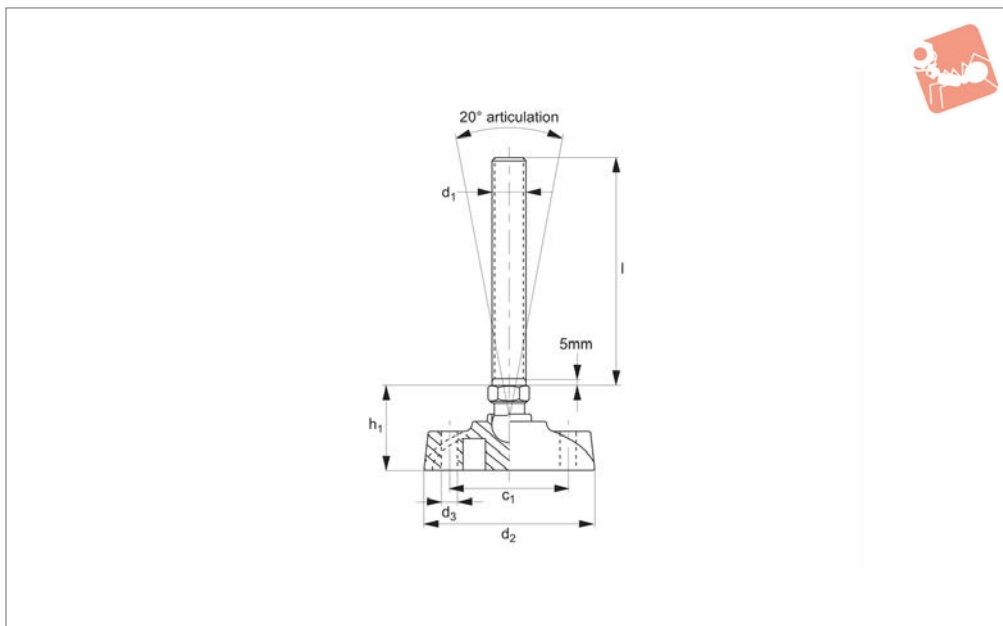

34742

LEVELLING FEET

Material

Pad: polyamide reinforced nylon.
Bolt: stainless steel AISI 303.

Technical Notes

Supplied with plastic mounting hole plugs, these prevent material and waste entering

the mounting holes, thus simplifying cleaning and maintenance.

Order No.	d ₁	d ₂	d ₃	l	c ₁	h ₁	Static load kN max.
34742.W0620	M12	100	10.5	75	70	42	10
34742.W0621	M12	100	10.5	125	70	42	10
34742.W0660	M16	100	10.5	75	70	45	20
34742.W0662	M16	100	10.5	150	70	45	20
34742.W0663	M16	100	10.5	200	70	45	20
34742.W0700	M20	100	10.5	125	70	49	20
34742.W0701	M20	100	10.5	150	70	49	20
34742.W0702	M20	100	10.5	200	70	49	20
34742.W0720	M24	100	10.5	125	70	53	20
34742.W0721	M24	100	10.5	150	70	53	20
34742.W0722	M24	100	10.5	200	70	53	20



34753

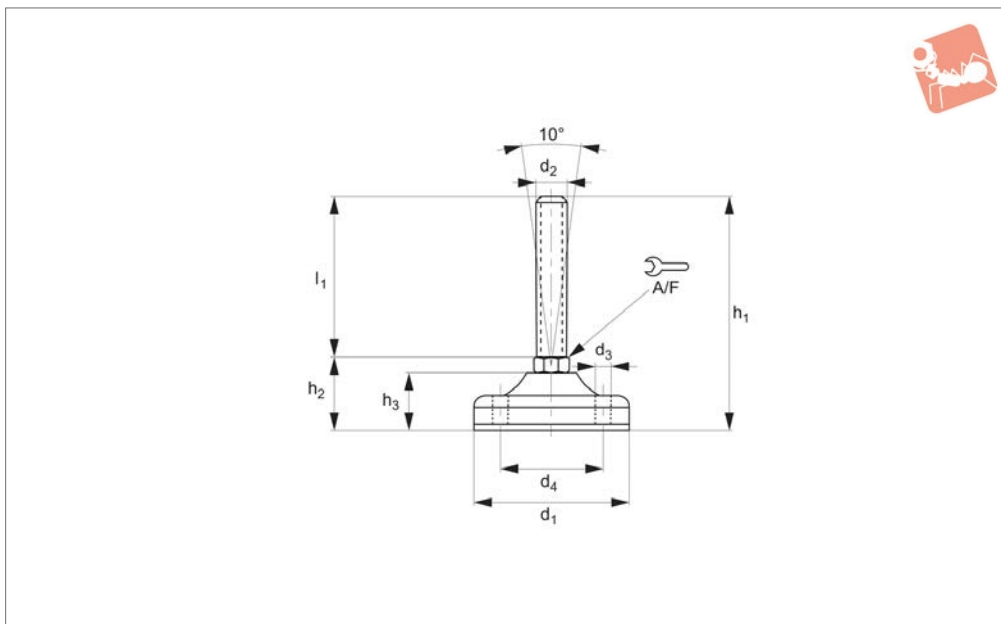

Material

Black plastic base (reinforced with fibre glass), with steel (C40) stud.

Technical Notes

Load values refer to static loads, located at half the screw height.

Order No.	d ₁	d ₂	d ₃	d ₄	l	h ₁	h ₂	h ₃	A/F
34753.W1601	83	M16	8.5	56	75	114	39	31	16
34753.W3006	123	M30	12.5	87	250	303	53	40	26



Fixed Feet

stainless with hex socket



Levelling Feet

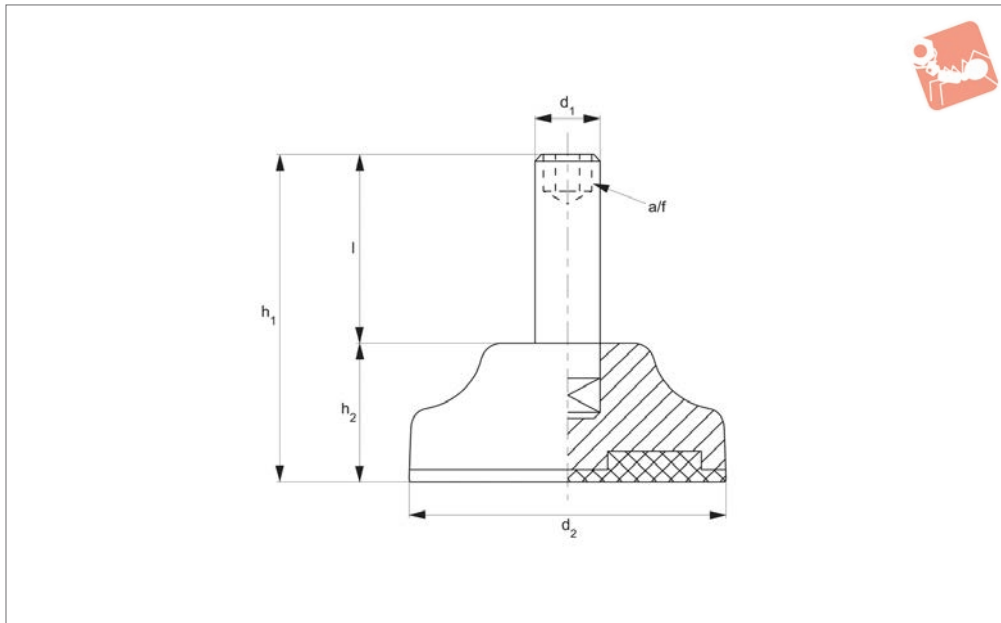

34612

LEVELLING FEET

Material

Pad: polyamide reinforced by fibre glass with anti-slip pad.
Bolt: stainless steel AISI 304.

Technical Notes

Load values refer to static loads, located at half the screw height.
When vibrations or dynamic loads are

present these values should be reduced.

Order No.	d ₁	d ₂	l	h ₁	h ₂	A/F	Load kN max.
34612.W0800	M 8	40	25	44	19	4	5
34612.W0801	M 8	40	50	69	19	4	5
34612.W0802	M 8	50	25	48	23	4	6
34612.W0803	M 8	50	50	73	23	4	6
34612.W1000	M10	40	25	44	19	5	5
34612.W1001	M10	40	50	69	19	5	5
34612.W1002	M10	50	25	48	23	5	6
34612.W1003	M10	50	50	73	23	5	6



34741

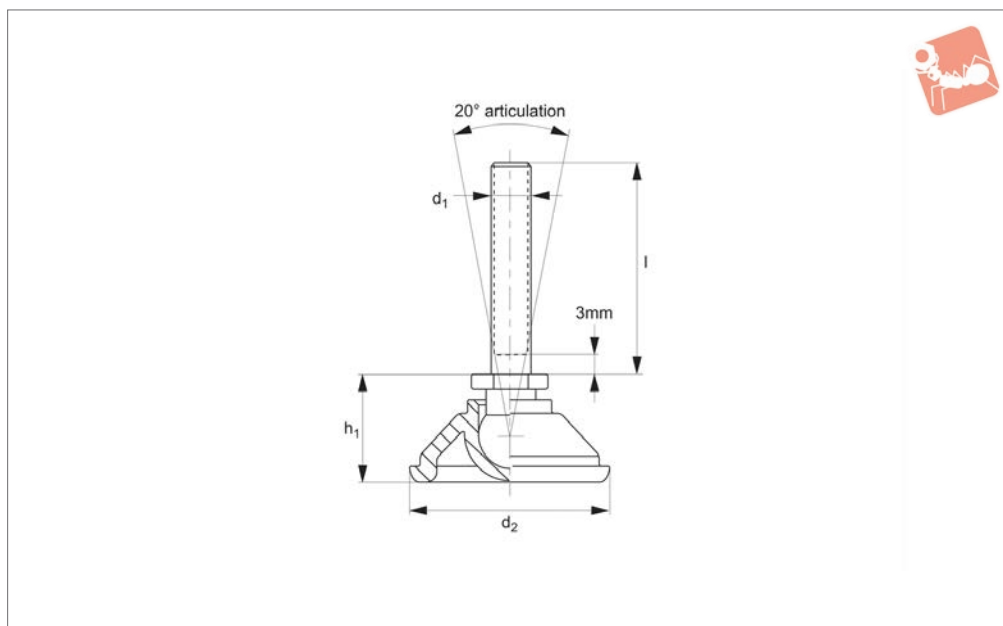

Material

Pad: polyamide reinforced nylon.

Bolt: stainless steel, AISI 303.

Order No.	d ₁	d ₂	l	h ₁	Static load kN max.
34741.W0060	M 6	40	20	21	3.0
34741.W0061	M 6	50	20	23	3.0
34741.W0062	M 6	40	40	21	3.0
34741.W0063	M 6	50	40	23	3.0
34741.W0080	M 8	40	25	21	4.5
34741.W0081	M 8	50	25	23	4.5
34741.W0082	M 8	40	40	21	4.5
34741.W0083	M 8	50	40	23	4.5
34741.W0084	M 8	40	60	21	4.5
34741.W0085	M 8	50	60	23	4.5
34741.W0100	M10	40	38	21	5.0
34741.W0101	M10	50	38	23	5.0
34741.W0102	M10	40	60	21	5.0
34741.W0103	M10	50	60	23	5.0
34741.W0104	M10	40	75	21	5.0
34741.W0105	M10	50	75	23	5.0
34741.W0120	M12	40	50	23	6.0
34741.W0121	M12	50	50	25	6.0
34741.W0122	M12	40	75	23	6.0
34741.W0123	M12	50	75	25	6.0
34741.W0124	M12	40	100	23	6.0
34741.W0125	M12	50	100	25	6.0
34741.W0126	M12	40	125	23	6.0
34741.W0127	M12	50	125	25	6.0
34741.W0128	M12	50	160	25	6.0

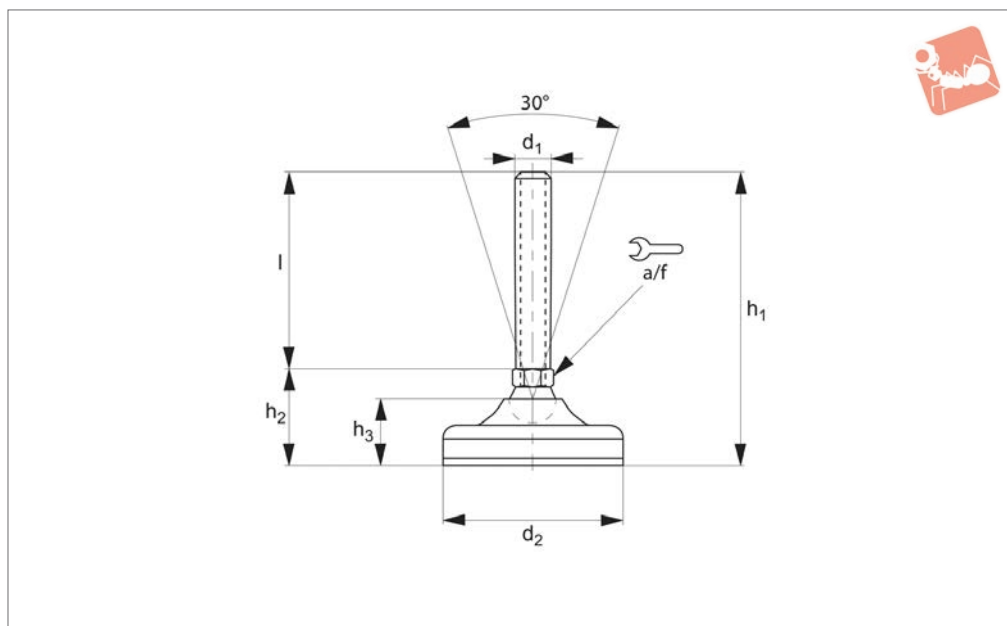

34743

LEVELLING FEET

Material

Pad: polyamide reinforced by fibre glass with anti-slip pad.

Bolt: stainless steel AISI 304.

Technical Notes

Load values refer to static loads, located at half the screw height.

When vibrations or dynamic loads are

present these values should be reduced.

Order No.	d ₁	d ₂	l	h ₁	h ₂	h ₃	A/F	Load kN max.
34743.W0800	M 8	40	25	55	30	19.5	12	10
34743.W0801	M 8	40	50	80	30	19.5	12	10
34743.W0802	M 8	40	75	105	30	19.5	12	10
34743.W0803	M 8	40	100	130	30	19.5	12	10
34743.W1001	M10	65	50	86	36	26.0	14	11
34743.W1002	M10	65	75	111	36	26.0	14	11
34743.W1003	M10	65	100	136	36	26.0	14	11
34743.W1004	M10	65	125	161	36	26.0	14	11
34743.W1200	M12	65	50	86	36	26.0	14	11
34743.W1201	M12	65	75	111	36	26.0	14	11
34743.W1202	M12	65	100	136	36	26.0	14	11
34743.W1203	M12	65	125	161	36	26.0	14	11
34743.W1400	M14	65	50	86	36	26.0	14	15
34743.W1401	M14	65	75	111	36	26.0	14	15
34743.W1402	M14	65	100	136	36	26.0	14	15
34743.W1403	M14	65	125	161	36	26.0	14	15
34743.W1404	M14	65	150	186	36	26.0	14	15
34743.W1405	M14	65	175	211	36	26.0	14	15
34743.W1600	M16	65	50	90	40	26.0	13	15
34743.W1601	M16	65	75	115	40	26.0	13	15
34743.W1602	M16	65	100	140	40	26.0	13	15
34743.W1603	M16	65	125	165	40	26.0	13	15
34743.W1604	M16	65	150	190	40	26.0	13	15
34743.W1605	M16	65	175	215	40	26.0	13	15
34743.W1606	M16	65	200	240	40	26.0	13	15
34743.W2000	M20	65	50	90	40	26.0	17	15
34743.W2001	M20	65	75	115	40	26.0	17	15
34743.W2002	M20	65	100	140	40	26.0	17	15
34743.W2003	M20	65	125	165	40	26.0	17	15
34743.W2004	M20	65	150	190	40	26.0	17	15
34743.W2005	M20	65	175	215	40	26.0	17	15
34743.W2006	M20	65	200	240	40	26.0	17	15



34744

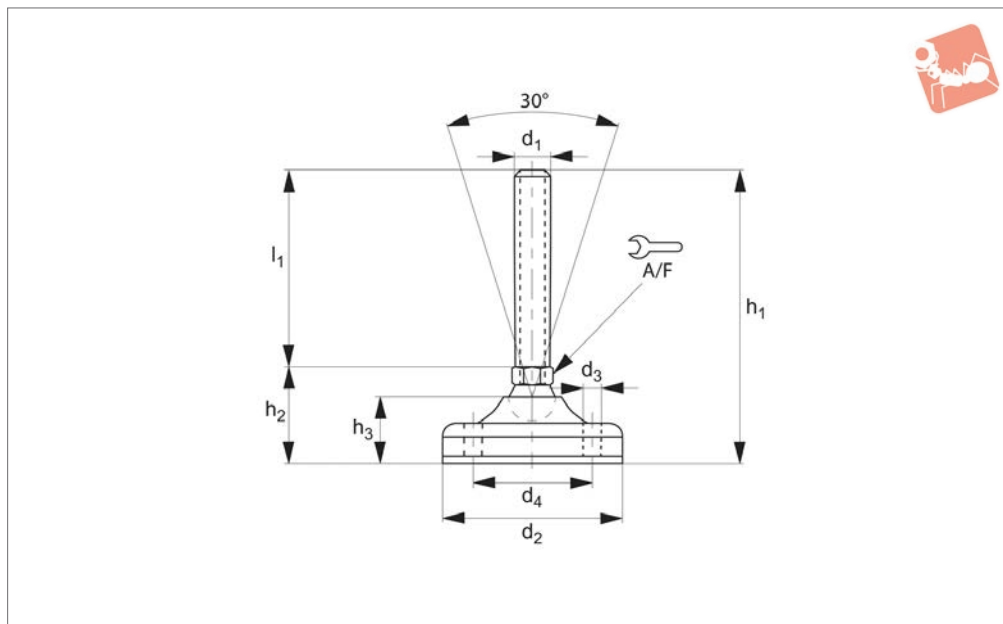

Material

Pad: polyamide reinforced by fibre glass with anti-slip pad.

Bolt: stainless steel AISI 304.

Technical Notes

Load values refer to static loads, located at half the screw height.

When vibrations or dynamic loads are

present these values should be reduced.

Larger pad size allows for bolt down holes to be drilled through.

Order No.	d ₁	l ₁	d ₂	d ₃	d ₄	h ₁	h ₂	h ₃	A/F	Load kN max.
34744.W1000	M10	50	83	8.5	55	91	38	27	14	15
34744.W1001	M10	75	83	8.5	55	116	38	27	14	15
34744.W1002	M10	100	83	8.5	55	141	38	27	14	15
34744.W1003	M10	125	83	8.5	55	166	38	27	14	15
34744.W1200	M12	50	83	8.5	55	91	38	27	14	15
34744.W1201	M12	75	83	8.5	55	116	38	27	14	15
34744.W1202	M12	100	83	8.5	55	141	38	27	14	15
34744.W1203	M12	125	83	8.5	55	166	38	27	14	15
34744.W1400	M14	50	83	8.5	55	91	38	27	14	20
34744.W1401	M14	75	83	8.5	55	116	38	27	14	20
34744.W1402	M14	100	83	8.5	55	141	38	27	14	20
34744.W1403	M14	125	83	8.5	55	166	38	27	14	20
34744.W1404	M14	150	83	8.5	55	191	38	27	14	20
34744.W1405	M14	175	83	8.5	55	216	38	27	14	20
34744.W1600	M16	50	83	8.5	55	94	41	27	13	20
34744.W1601	M16	75	83	8.5	55	119	41	27	13	20
34744.W1602	M16	100	83	8.5	55	144	41	27	13	20
34744.W1603	M16	125	83	8.5	55	169	41	27	13	20
34744.W1604	M16	150	83	8.5	55	194	41	27	13	20
34744.W1605	M16	175	83	8.5	55	219	41	27	13	20
34744.W1606	M16	200	83	8.5	55	244	41	27	13	20
34744.W1607	M16	50	103	12.5	73	104	51	32	20	25
34744.W1608	M16	75	103	12.5	73	129	51	32	20	25
34744.W1609	M16	100	103	12.5	73	154	51	32	20	25
34744.W1610	M16	125	103	12.5	73	179	51	32	20	25
34744.W1611	M16	150	103	12.5	73	204	51	32	20	25
34744.W1612	M16	175	103	12.5	73	229	51	32	20	25
34744.W1613	M16	200	103	12.5	73	254	51	32	20	25
34744.W1614	M16	225	103	12.5	73	279	51	32	20	25
34744.W2000	M20	75	83	8.5	55	119	41	27	17	20
34744.W2001	M20	100	83	8.5	55	144	41	27	17	20
34744.W2002	M20	125	83	8.5	55	169	41	27	17	20
34744.W2003	M20	150	83	8.5	55	194	41	27	17	20



Levelling Feet

bolt down option, bolt **stainless steel**



Levelling Feet

Order No.	d ₁	l ₁	d ₂	d ₃	d ₄	h ₁	h ₂	h ₃	A/F	Load kN max.
34744.W2004	M20	175	83	8.5	55	219	41	27	17	20
34744.W2005	M20	200	83	8.5	55	244	41	27	17	20
34744.W2006	M20	225	83	8.5	55	269	41	27	17	20
34744.W2007	M20	75	103	12.5	73	129	51	32	20	25
34744.W2008	M20	100	103	12.5	73	154	51	32	20	25
34744.W2009	M20	125	103	12.5	73	179	51	32	20	25
34744.W2010	M20	150	103	12.5	73	204	51	32	20	25
34744.W2011	M20	175	103	12.5	73	229	51	32	20	25
34744.W2012	M20	200	103	12.5	73	254	51	32	20	25
34744.W2013	M20	225	103	12.5	73	279	51	32	20	25
34744.W2014	M20	250	103	12.5	73	304	51	32	20	25
34744.W2400	M24	75	103	12.5	73	129	51	32	20	25
34744.W2401	M24	100	103	12.5	73	154	51	32	20	25
34744.W2402	M24	125	103	12.5	73	179	51	32	20	25
34744.W2403	M24	150	103	12.5	73	204	51	32	20	25
34744.W2404	M24	175	103	12.5	73	229	51	32	20	25
34744.W2405	M24	200	103	12.5	73	280	51	32	20	25
34744.W2406	M24	250	103	12.5	73	302	51	32	20	25
34744.W2407	M24	250	103	12.5	73	305	51	32	20	25

LEVELLING FEET



34746

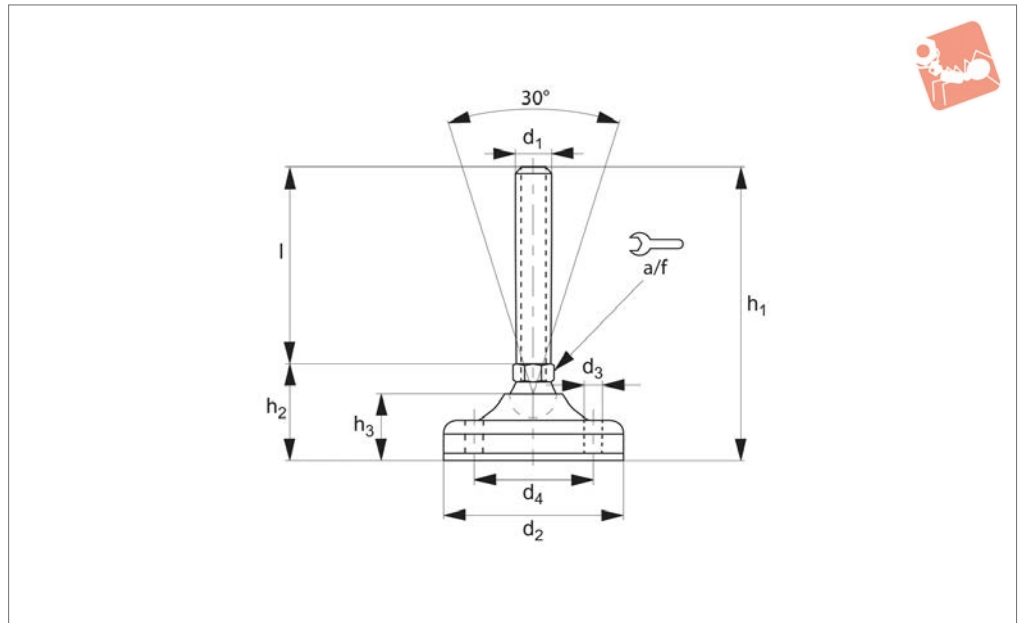

Material

Pad: polyamide reinforced by fibre glass with anti-slip pad.
 Bolt: stainless steel AISI 304.

Technical Notes

Load values refer to static loads, located at half the screw height.
 When vibrations or dynamic loads are

present these values should be reduced.
 Larger pad size allows for bolt down holes to be drilled through.

Order No.	d ₁	d ₂	l	d ₃	d ₄	h ₁	h ₂	h ₃	A/F	Load kN max.
34746.W1600	M16	123	50	12.5	87	110	60	40	20	35
34746.W1601	M16	123	75	12.5	87	135	60	40	20	35
34746.W1602	M16	123	100	12.5	87	160	60	40	20	35
34746.W1603	M16	123	125	12.5	87	185	60	40	20	35
34746.W1604	M16	123	150	12.5	87	210	60	40	20	35
34746.W1605	M16	123	175	12.5	87	235	60	40	20	35
34746.W1606	M16	123	200	12.5	87	260	60	40	20	35
34746.W1607	M16	123	225	12.5	87	285	60	40	20	35
34746.W2000	M20	123	75	12.5	87	135	60	40	20	35
34746.W2001	M20	123	100	12.5	87	160	60	40	20	35
34746.W2002	M20	123	125	12.5	87	185	60	40	20	35
34746.W2003	M20	123	150	12.5	87	210	60	40	20	35
34746.W2004	M20	123	175	12.5	87	235	60	40	20	35
34746.W2005	M20	123	200	12.5	87	260	60	40	20	35
34746.W2006	M20	123	225	12.5	87	285	60	40	20	35
34746.W2007	M20	123	250	12.5	87	310	60	40	20	35
34746.W2400	M24	123	75	12.5	87	135	60	40	20	35
34746.W2401	M24	123	100	12.5	87	160	60	40	20	35
34746.W2402	M24	123	125	12.5	87	185	60	40	20	35
34746.W2403	M24	123	150	12.5	87	210	60	40	20	35
34746.W2404	M24	123	175	12.5	87	235	60	40	20	35
34746.W2405	M24	123	200	12.5	87	260	60	40	20	35
34746.W2406	M24	123	225	12.5	87	285	60	40	20	35
34746.W2407	M24	123	250	12.5	87	310	60	40	20	35
34746.W3000	M30	123	100	12.5	87	161	61	40	26	35
34746.W3001	M30	123	125	12.5	87	186	61	40	26	35
34746.W3002	M30	123	150	12.5	87	211	61	40	26	35
34746.W3003	M30	123	175	12.5	87	236	61	40	26	35
34746.W3004	M30	123	200	12.5	87	261	61	40	26	35
34746.W3005	M30	123	225	12.5	87	286	61	40	26	35
34746.W3006	M30	123	250	12.5	87	311	61	40	26	35



Machine Mount - Vibration Damp- pad and bolt - stainless steel

Levelling Feet

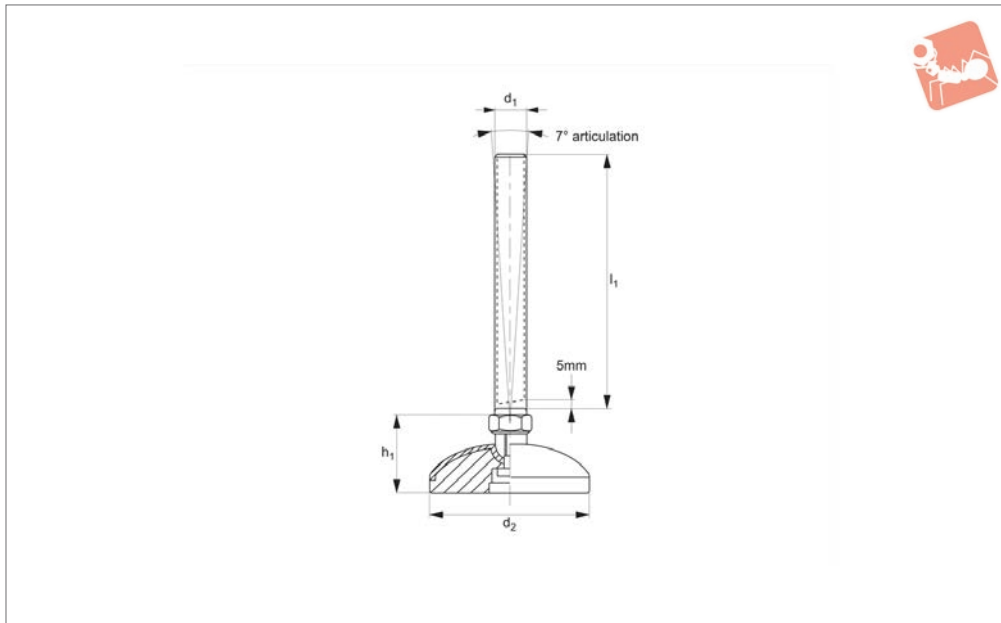

34751

LEVELLING FEET

Material

Pad: pressed stainless steel AISI 303.
Bolt: stainless steel AISI 303.
Pad insert: nitril rubber.

part ref 65686.

Tips

For use in wide range of industries including food processing, medical equipment, electronics and machinery workshops.

Technical Notes

Lock nuts available separately. Please see

Order No.	d ₁	l ₁	d ₂	h ₁	Static load kN max.
34751.W0100	M10	50	50	25	3.5
34751.W0101	M10	100	50	25	3.5
34751.W0120	M12	100	50	25	3.5
34751.W0121	M12	150	50	25	3.5
34751.W0160	M16	100	50	28	3.5
34751.W0161	M16	150	50	28	3.5
34751.W0162	M16	100	75	33	7.5
34751.W0163	M16	150	75	33	7.5
34751.W0164	M16	200	75	33	7.5
34751.W0165	M16	100	100	38	10.0
34751.W0166	M16	150	100	38	10.0
34751.W0167	M16	200	100	38	10.0
34751.W0200	M20	150	75	35	7.5
34751.W0201	M20	200	75	35	7.5
34751.W0202	M20	150	100	41	10.0
34751.W0203	M20	200	100	41	10.0
34751.W0240	M24	150	100	43	10.0
34751.W0241	M24	250	100	43	10.0



34752

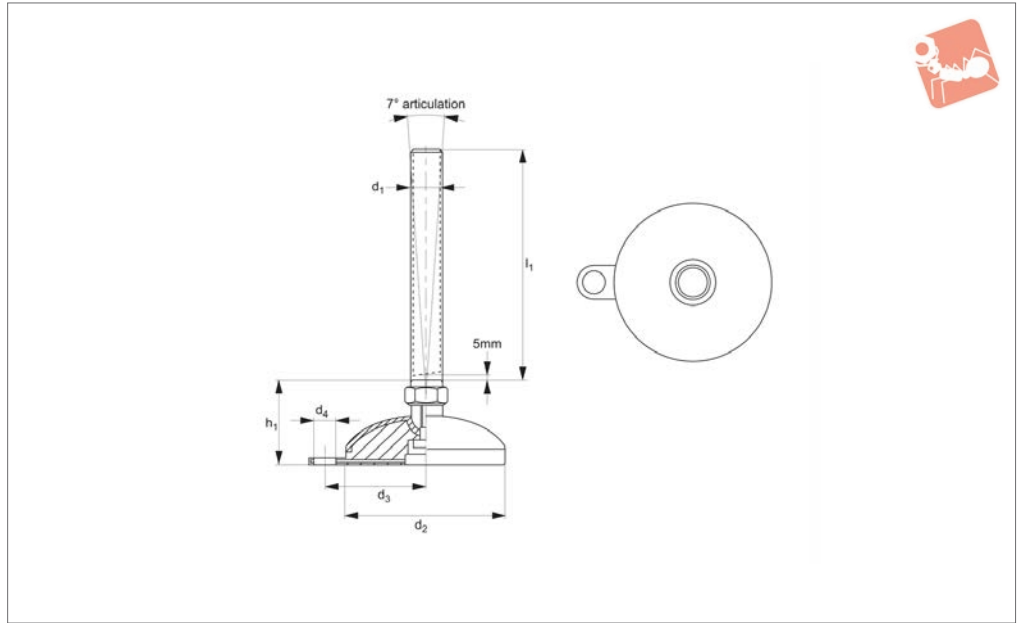

Material

Pad: pressed stainless steel AISI 303.
Bolt: stainless steel AISI 303.
Pad insert: nitril rubber.

Technical Notes

Use of the bolt down tag allows the

machine mount to be fixed in place.

Tips

For use in wide range of industries including food processing, medical equipment, electronics and machinery workshops.

Order No.	d_1	l_1	d_2	d_3	d_4	h_1	Static load kN max.
34752.W0662	M16	100	75	52	13	33	7.5
34752.W0663	M16	150	75	52	13	33	7.5
34752.W0664	M16	200	75	52	13	33	7.5
34752.W0665	M16	100	100	67	13	38	10.0
34752.W0666	M16	150	100	67	13	38	10.0
34752.W0667	M16	200	100	67	13	38	10.0
34752.W0700	M20	150	75	52	13	33	7.5
34752.W0701	M20	200	75	52	13	33	7.5
34752.W0702	M20	150	100	67	13	41	10.0
34752.W0703	M20	200	100	67	13	41	10.0
34752.W0740	M24	150	100	67	13	43	10.0
34752.W0741	M24	200	100	67	13	43	10.0



Levelling Feet

pad thermoplastic, bolt stainless steel



Levelling Feet

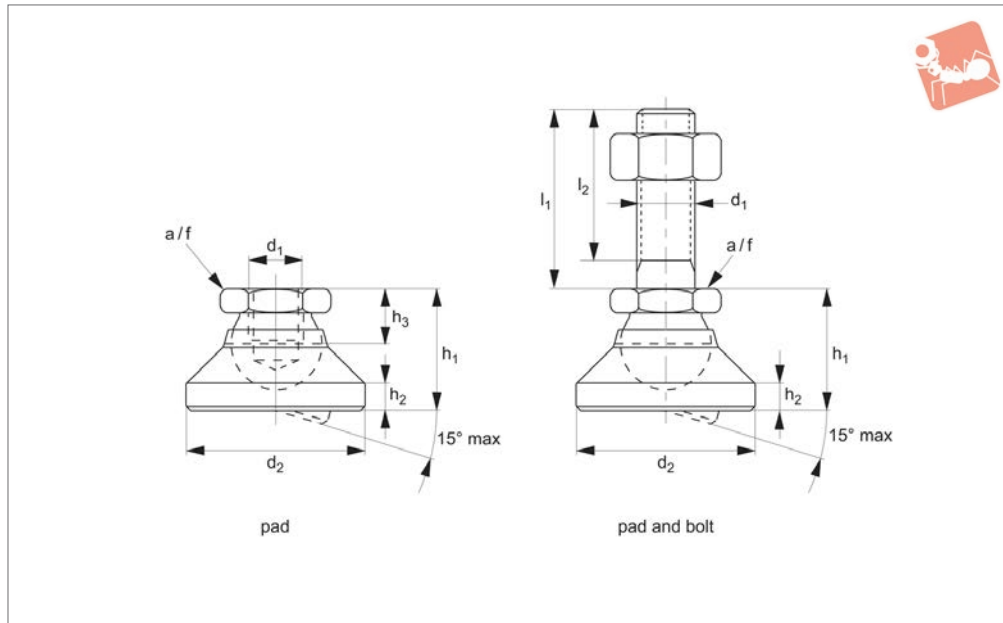

34760

LEVELLING FEET

Material

Pad: white thermoplastic (POM).

Bolt: stainless steel 1.4305 (AISI 303).

Lock nut: Stainless steel A2, DIN 934/ISO 4032.

Technical Notes

For use as feet and thrust pads.

Order No.	Type	d ₁	l ₁	d ₂	l ₂	h ₁ ≈	h ₂	h ₃	Static load kN max.	A/F	Weight g
34760.W0106	Pad	M 6	-	20	-	14	2.5	5.0	4	10	6
34760.W0108	Pad	M 8	-	25	-	18	4.0	7.0	7	13	13
34760.W0110	Pad	M10	-	32	-	22	5.0	9.0	10	17	26
34760.W0112	Pad	M12	-	40	-	26	6.0	11.0	18	19	40
34760.W0116	Pad	M16	-	50	-	32	7.0	13.5	20	24	75
34760.W0120	Pad	M20	-	60	-	42	8.0	17.0	22	30	120
34760.W0124	Pad	M24	-	60	-	45	9.5	19.0	25	36	184
34760.W0510	Pad and Bolt	M 6	60	20	57.0	14	2.5	-	4	10	20
34760.W0522	Pad and Bolt	M 8	80	25	76.0	18	4.0	-	7	13	46
34760.W0538	Pad and Bolt	M10	100	32	95.5	22	5.0	-	10	17	92
34760.W0542	Pad and Bolt	M10	150	32	145.5	22	5.0	-	10	17	118
34760.W0552	Pad and Bolt	M12	100	40	94.5	26	6.0	-	18	19	139
34760.W0556	Pad and Bolt	M12	150	40	144.5	26	6.0	-	18	19	173
34760.W0568	Pad and Bolt	M16	100	50	94.0	32	7.0	-	20	24	264
34760.W0572	Pad and Bolt	M16	200	50	194.0	32	7.0	-	20	24	393
34760.W0582	Pad and Bolt	M20	100	60	92.5	42	8.0	-	22	30	463
34760.W0588	Pad and Bolt	M20	200	60	192.5	42	8.0	-	22	30	664
34760.W0595	Pad and Bolt	M24	100	60	91.0	45	9.5	-	25	36	662
34760.W0598	Pad and Bolt	M24	200	60	191.0	45	9.5	-	25	36	960

Levelling Feet



Levelling Feet
pad thermoplastic, bolt stainless steel



LEVELLING FEET

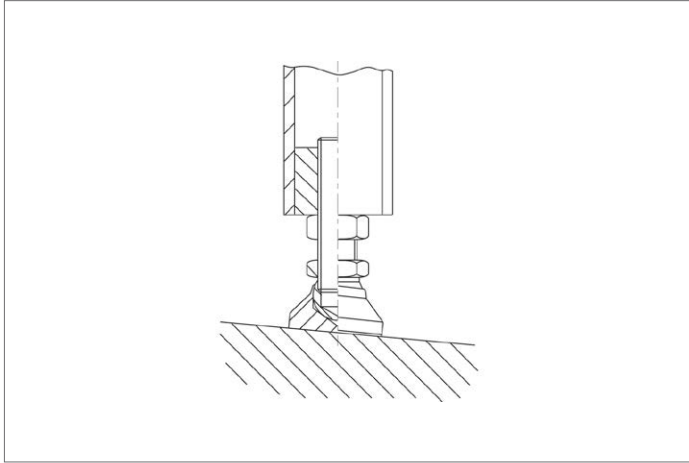



Machine Mount

plastic pad, bolt black polyamide bolt down option



Levelling Feet

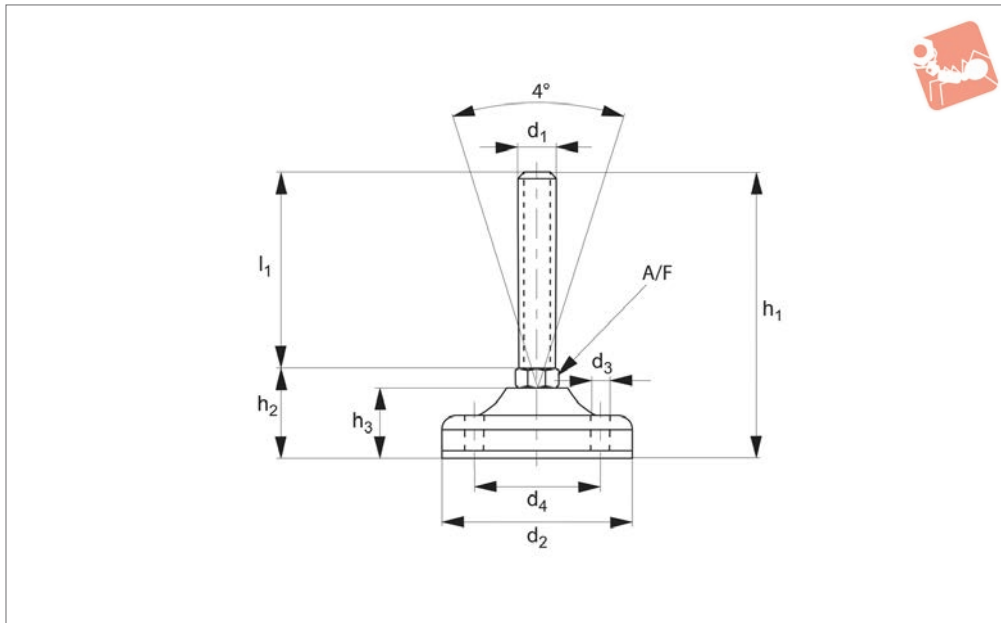

34754

LEVELLING FEET

Material

Pad: black polyamide.
Bolt: stainless steel AISI 303.

Pad insert: nitril rubber.

half the screw height.

Technical Notes

Load values refer to static loads, located at

Order No.	d ₁	l ₁	d ₂	d ₃	d ₄	h ₁	h ₂	h ₃	A/F	Load kN max.
34754.W1000	M10	50	83	8.5	56	89	39	31	14	15
34754.W1001	M10	75	83	8.5	56	114	39	31	14	15
34754.W1002	M10	100	83	8.5	56	139	39	31	14	15
34754.W1003	M10	125	83	8.5	56	164	39	31	14	15
34754.W1200	M12	50	83	8.5	56	89	39	31	14	15
34754.W1201	M12	75	83	8.5	56	114	39	31	14	15
34754.W1202	M12	100	83	8.5	56	139	39	31	14	15
34754.W1203	M12	125	83	8.5	56	164	39	31	14	15
34754.W1400	M14	50	83	8.5	56	89	39	31	14	20
34754.W1401	M14	75	83	8.5	56	114	39	31	14	20
34754.W1402	M14	100	83	8.5	56	139	39	31	14	20
34754.W1403	M14	125	83	8.5	56	164	39	31	14	20
34754.W1404	M14	150	83	8.5	56	189	39	31	14	20
34754.W1405	M14	175	83	8.5	56	215	39	31	14	20
34754.W1600	M16	50	83	8.5	56	93	43	31	13	20
34754.W1601	M16	75	83	8.5	56	118	43	31	13	20
34754.W1602	M16	100	83	8.5	56	143	43	31	13	20
34754.W1603	M16	125	83	8.5	56	168	43	31	13	20
34754.W1604	M16	150	83	8.5	56	193	43	31	13	20
34754.W1605	M16	175	83	8.5	56	218	43	31	13	20
34754.W1606	M16	200	83	8.5	56	243	43	31	13	20
34754.W1607	M16	50	103	12.5	73	98	48	36	17	35
34754.W1608	M16	75	103	12.5	73	123	48	36	17	35
34754.W1609	M16	100	103	12.5	73	148	48	36	17	35
34754.W1610	M16	125	103	12.5	73	173	48	36	17	35
34754.W1611	M16	150	103	12.5	73	198	48	36	17	35
34754.W1612	M16	175	103	12.5	73	223	48	36	17	35
34754.W1613	M16	200	103	12.5	73	248	48	36	17	35
34754.W1614	M16	225	103	12.5	73	273	48	36	17	35
34754.W1615	M16	50	123	12.5	87	103	53	40	20	45
34754.W1616	M16	75	123	12.5	87	128	53	40	20	45
34754.W1617	M16	100	123	12.5	87	153	53	40	20	45
34754.W1618	M16	125	123	12.5	87	178	53	40	20	45
34754.W1619	M16	150	123	12.5	87	203	53	40	20	45

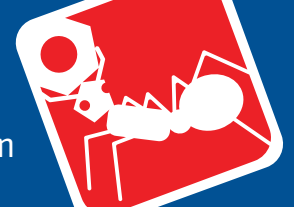

Order No.	d ₁	l ₁	d ₂	d ₃	d ₄	h ₁	h ₂	h ₃	A/F	Load kN max.
34754.W1620	M16	175	123	12.5	87	228	53	40	20	45
34754.W1621	M16	200	123	12.5	87	253	53	40	20	45
34754.W1622	M16	225	123	12.5	87	278	53	40	20	45
34754.W2000	M20	75	83	8.5	56	118	43	34	17	20
34754.W2001	M20	100	83	8.5	56	143	43	34	17	20
34754.W2002	M20	125	83	8.5	56	168	43	34	17	20
34754.W2003	M20	150	83	8.5	56	193	43	34	17	20
34754.W2004	M20	175	83	8.5	56	218	43	34	17	20
34754.W2005	M20	200	83	8.5	56	243	43	34	17	20
34754.W2006	M20	225	83	8.5	56	268	43	34	17	20
34754.W2007	M20	75	103	12.5	73	123	48	36	17	35
34754.W2008	M20	100	103	12.5	73	148	48	36	17	35
34754.W2009	M20	125	103	12.5	73	173	48	36	17	35
34754.W2010	M20	150	103	12.5	73	198	48	36	17	35
34754.W2011	M20	175	103	12.5	73	223	48	36	17	35
34754.W2012	M20	200	103	12.5	73	248	48	36	17	35
34754.W2013	M20	225	103	12.5	73	273	48	36	17	35
34754.W2014	M20	75	123	12.5	87	128	53	40	20	45
34754.W2015	M20	100	123	12.5	87	153	53	40	20	45
34754.W2016	M20	125	123	12.5	87	178	53	40	20	45
34754.W2017	M20	150	123	12.5	87	203	53	40	20	45
34754.W2018	M20	175	123	12.5	87	228	53	40	20	45
34754.W2019	M20	200	123	12.5	87	253	53	40	20	45
34754.W2020	M20	225	123	12.5	87	278	53	40	20	45
34754.W2400	M24	75	103	12.5	73	125	50	36	20	35
34754.W2401	M24	100	103	12.5	73	150	50	36	20	35
34754.W2402	M24	125	103	12.5	73	175	50	36	20	35
34754.W2403	M24	150	103	12.5	73	200	50	36	20	35
34754.W2404	M24	175	103	12.5	73	225	50	36	20	35
34754.W2405	M24	200	103	12.5	73	250	50	36	20	35
34754.W2406	M24	225	103	12.5	73	275	50	36	20	35
34754.W2407	M24	75	123	12.5	87	128	53	40	20	45
34754.W2408	M24	100	123	12.5	87	153	53	40	20	45
34754.W2409	M24	125	123	12.5	87	178	53	40	20	45
34754.W2410	M24	150	123	12.5	87	203	53	40	20	45
34754.W2411	M24	175	123	12.5	87	228	53	40	20	45
34754.W2412	M24	200	123	12.5	87	253	53	40	20	45
34754.W2413	M24	225	123	12.5	87	278	53	40	20	45
34754.W2414	M24	250	123	12.5	87	303	53	40	20	45
34754.W3000	M30	100	123	12.5	87	153	53	40	26	45
34754.W3001	M30	125	123	12.5	87	178	53	40	26	45
34754.W3002	M30	150	123	12.5	87	203	53	40	26	45
34754.W3003	M30	175	123	12.5	87	228	53	40	26	45
34754.W3004	M30	200	123	12.5	87	253	53	40	26	45
34754.W3005	M30	225	123	12.5	87	278	53	40	26	45
34754.W3006	M30	250	123	12.5	87	303	53	40	26	45



Levelling Feet - Non Slip

pad thermoplastic, bolt stainless steel

Levelling Feet

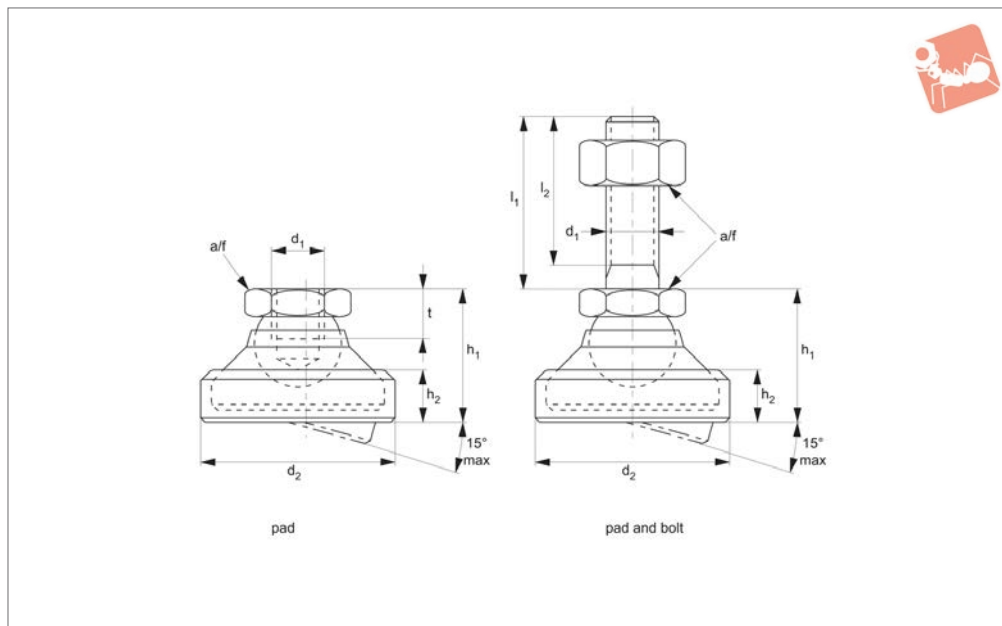

34761

LEVELLING FEET

Material

Pad: white thermoplastic (POM).
 Bolt: stainless steel 1.4305 (AISI 303).
 Lock nut: Stainless steel A2, DIN 934/ISO 4032.(M10, M12 only).

Cap: Black Rubber

Tips

To be used as feet and thrust pads. Used for levelling up to 15° on surface.

Also used:

34701 - Levelling Feet
 34700 - Levelling Feet - steel/stainless, non slip.

Order No.	Type	d ₁	l ₁	d ₂	l ₂	h ₁ ≈	h ₂	Static load kN max.	t	A/F	Weight g
34761.W1106	Pad	M 6	-	22.5	-	16.5	6.4	4	5.0	10	7
34761.W1108	Pad	M 8	-	28.0	-	20.6	8.3	7	7.0	13	16
34761.W1110	Pad	M10	-	36.0	-	26.0	11.0	10	9.0	17	32
34761.W1112	Pad	M12	-	45.0	-	30.5	13.2	18	11.0	19	51
34761.W1116	Pad	M16	-	56.0	-	37.5	15.5	20	13.5	24	96
34761.W1120	Pad	M20	-	67.0	-	49.5	19.5	22	17.0	30	190
34761.W1124	Pad	M24	-	69.0	-	55.0	24.0	25	19.0	36	240
34761.W1510	Pad and Bolt	M 6	60	22.5	57.0	16.5	6.4	4	-	10	21
34761.W1522	Pad and Bolt	M 8	80	28.0	76.0	20.6	8.3	7	-	13	49
34761.W1538	Pad and Bolt	M10	100	36.0	95.5	26.0	11.0	10	-	17	98
34761.W1542	Pad and Bolt	M10	150	36.0	145.5	26.0	11.0	10	-	17	124
34761.W1552	Pad and Bolt	M12	100	45.0	94.5	30.5	13.2	18	-	19	150
34761.W1556	Pad and Bolt	M12	150	45.0	144.5	30.5	13.2	18	-	19	184
34761.W1568	Pad and Bolt	M16	100	56.0	94.0	37.5	15.5	20	-	24	285
34761.W1572	Pad and Bolt	M16	200	56.0	194.0	37.5	15.5	20	-	24	414
34761.W1582	Pad and Bolt	M20	100	67.0	92.5	49.5	19.5	22	-	30	503
34761.W1588	Pad and Bolt	M20	200	67.0	192.5	49.5	19.5	22	-	30	704
34761.W1595	Pad and Bolt	M24	100	69.0	91.0	55.0	24.0	25	-	36	718
34761.W1598	Pad and Bolt	M24	200	69.0	191.0	55.0	24.0	25	-	36	1016



LEVELLING FEET

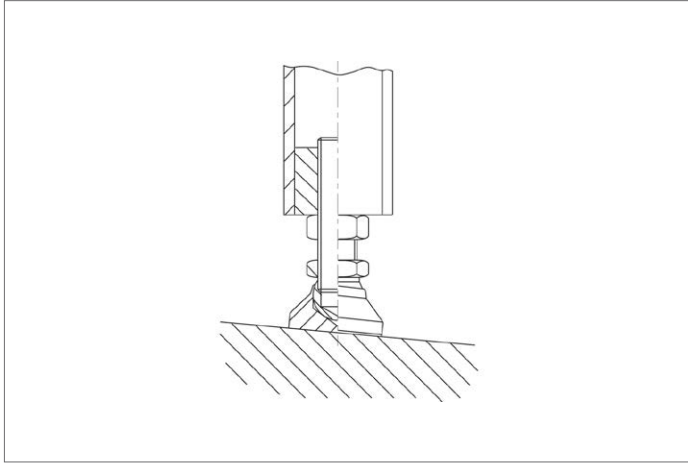



Machine Feet - Low Profile

pad and bolt **stainless steel**

Levelling Feet

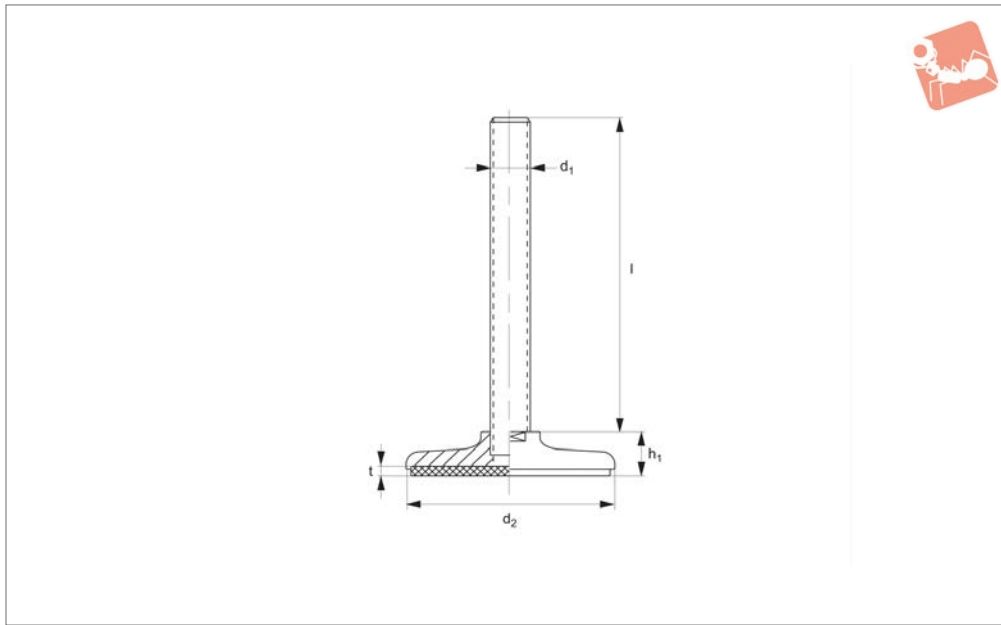

34780

LEVELLING FEET

Material

Pad & bolt: AISI 304 stainless steel.
Inset nitrile rubber pad.

Technical Notes

Suitable for use in food & drink, pharmaceutical and clean room environments.

Order No.	d ₁	d ₂	l	h ₁	Static load kN max.	t
34780.W0082	M 8	40	40	12	4.5	3
34780.W0084	M 8	40	60	12	4.5	3
34780.W0100	M10	40	40	12	6.0	3
34780.W0102	M10	40	60	12	6.0	3
34780.W0104	M10	40	80	12	6.0	3
34780.W0086	M 8	50	40	14	4.5	3
34780.W0088	M 8	50	60	14	4.5	3
34780.W0106	M10	50	40	14	6.0	3
34780.W0108	M10	50	60	14	6.0	3
34780.W0110	M10	50	80	14	6.0	3
34780.W0120	M12	50	50	15	7.5	3
34780.W0121	M12	50	75	15	7.5	3
34780.W0123	M12	50	100	15	7.5	3
34780.W0125	M12	60	75	15	12.5	3
34780.W0126	M12	60	125	15	12.5	3
34780.W0127	M12	60	150	15	12.5	3
34780.W0128	M12	80	150	21	15.0	3
34780.W0161	M16	80	150	21	20.0	3
34780.W0162	M16	120	150	24	20.0	3
34780.W0201	M20	120	200	24	30.0	3
34780.W0202	M20	150	200	26	30.0	3
34780.W0241	M24	150	200	26	40.0	3



34610

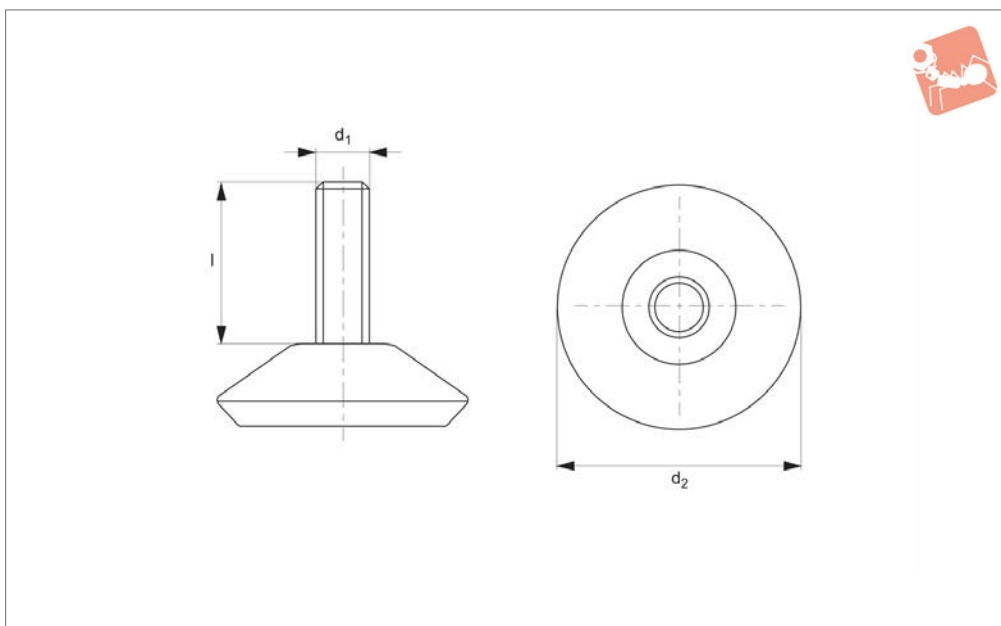

Material

Thread: steel, zinc plated.
Pad: thermoplastic, black.

Order No.	d ₁	d ₂	l
34610.W0030	M 8	30	27
34610.W0032	M 8	30	32
34610.W0041	M 8	40	22
34610.W0042	M 8	40	32
34610.W0044	M10	40	27
34610.W0046	M10	40	32
34610.W0056	M10	50	32
34610.W0066	M10	60	32
34610.W0067	M10	60	45

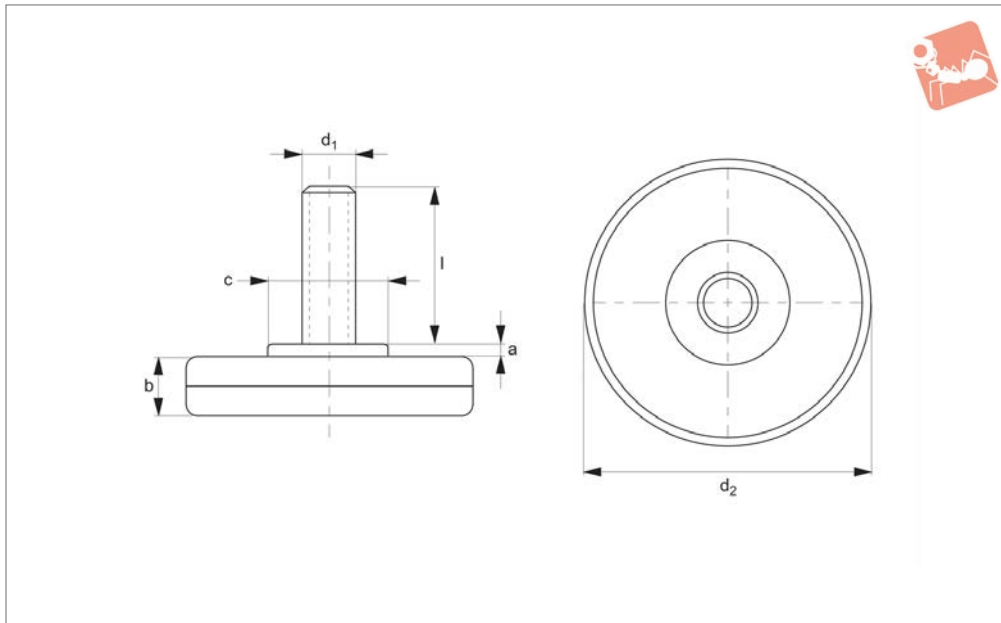

34620

LEVELLING FEET

Material

Thread: steel, zinc plated.
Pad: thermoplastic, black.

Order No.	d ₁	d ₂	l	c	b	a
34620.W0020	M 8	25	17	18	8	2
34620.W0021	M 8	25	22	18	8	2
34620.W0022	M 8	25	27	18	8	2
34620.W0031	M 8	30	27	18	8	2
34620.W0042	M 8	40	32	20	9	2
34620.W0045	M10	40	22	20	9	2
34620.W0046	M10	40	32	20	9	2
34620.W0055	M10	50	22	22	10	2
34620.W0056	M10	50	32	22	10	2
34620.W0065	M10	60	37	22	10	2
34620.W0066	M10	60	27	22	10	2
34620.W0085	M10	80	22	26	10	2
34620.W0086	M10	80	32	26	10	2
34620.W0087	M10	80	37	26	10	2



34630

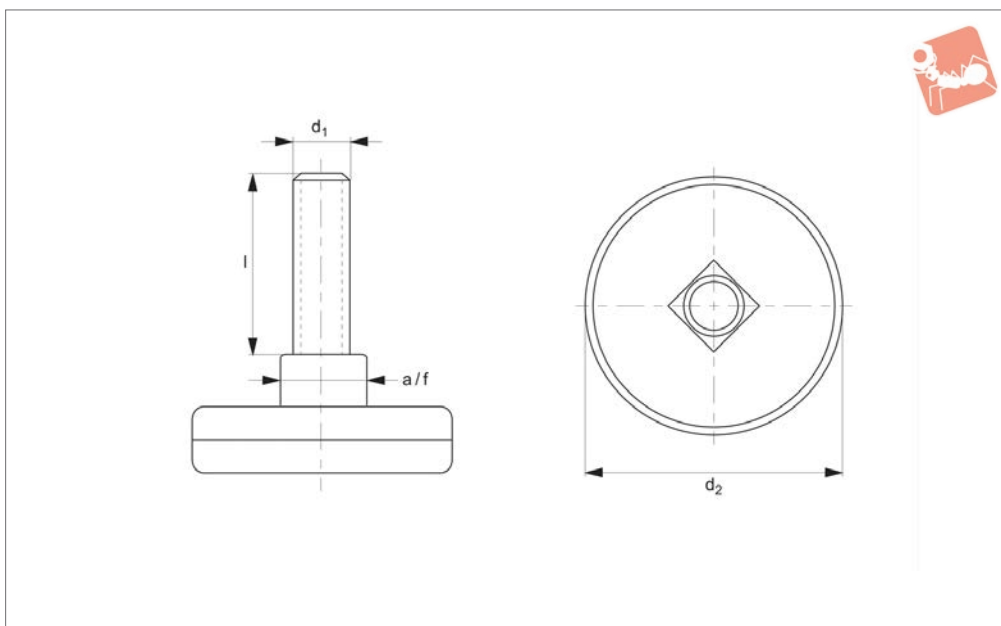

Material

Thread: steel, zinc plated.
Pad: thermoplastic, black.

Order No.	d ₁	d ₂	l	A/F
34630.W0011	M 8	19	22	14
34630.W0013	M 8	19	27	14
34630.W0036	M 8	30	22	17
34630.W0038	M10	30	27	17
34630.W0041	M 8	40	22	17
34630.W0042	M 8	40	32	17
34630.W0045	M10	40	22	17
34630.W0046	M10	40	32	17
34630.W0051	M 8	50	22	17
34630.W0054	M10	50	27	17
34630.W0056	M10	50	32	17
34630.W0062	M 8	60	32	17
34630.W0063	M 8	60	42	17
34630.W0066	M10	60	32	17
34630.W0067	M10	60	45	17

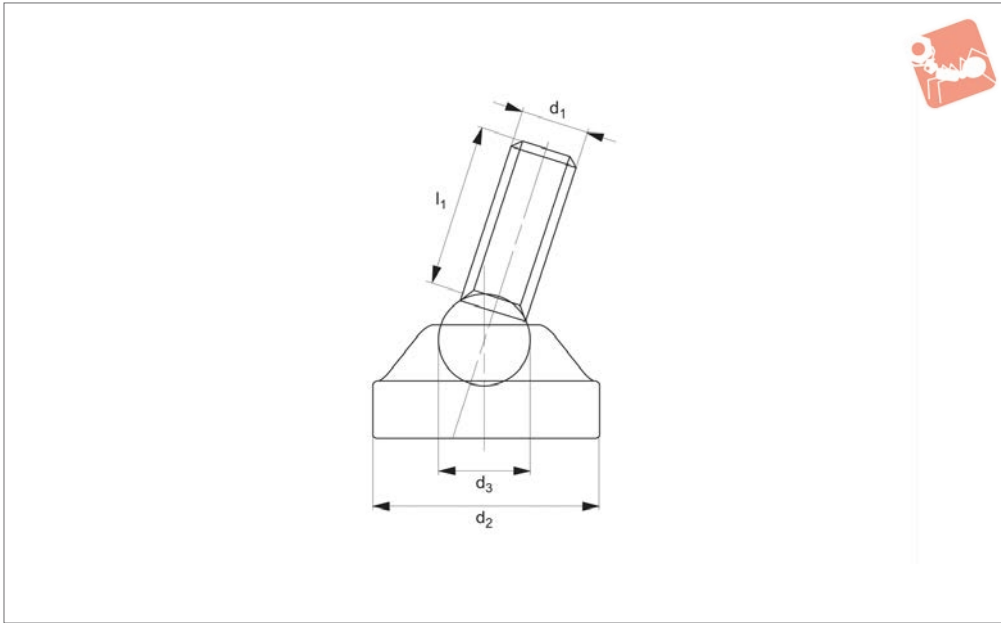

34640

LEVELLING FEET

Material

Thread: steel, zinc plated.
Pad: thermoplastic, black.

Order No.	d ₁	d ₂	d ₃	l ₁
34640.W0018	M 8	24	10	18



34650

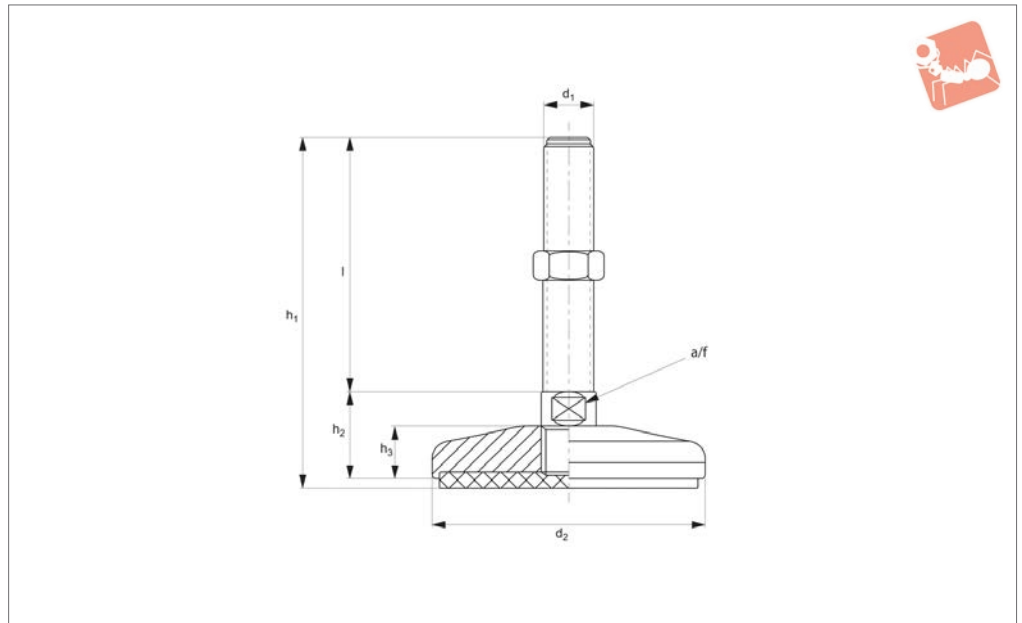

Material

Stainless steel (AISI 304), with rubber pad (70 Shore A).
Stainless steel (AISI 316) version available

on request.

Technical Notes

Load values refer to static loads, located at

half the screw height.

When vibrations or dynamic loads are present these values should be reduced.

Order No.	d ₁	d ₂	l	h ₁	h ₂	h ₃	A/F	Load kN max.
34650.W1600	M16	80	100	134.5	31.5	19	17	30
34650.W1601	M16	80	150	184.5	31.5	19	17	30
34650.W1602	M16	80	200	234.5	31.5	19	17	30
34650.W1603	M16	100	100	136.0	33.0	20	20	40
34650.W1604	M16	100	150	186.0	33.0	20	20	40
34650.W1605	M16	100	200	236.0	33.0	20	20	40
34650.W2000	M20	80	100	134.5	31.5	19	20	35
34650.W2001	M20	80	150	184.5	31.5	19	20	35
34650.W2002	M20	80	200	234.5	31.5	19	20	35
34650.W2003	M20	80	225	259.5	31.5	19	20	35
34650.W2004	M20	100	100	136.0	33.0	20	20	45
34650.W2005	M20	100	150	186.0	33.0	20	20	45
34650.W2006	M20	100	200	236.0	33.0	20	20	45
34650.W2007	M20	100	250	286.0	33.0	20	20	45
34650.W2008	M20	120	100	138.0	35.0	22	20	45
34650.W2009	M20	120	150	188.0	35.0	22	20	45
34650.W2100	M20	120	200	238.0	35.0	22	20	45
34650.W2101	M20	120	250	288.0	35.0	22	20	45
34650.W2102	M20	159	100	139.0	36.0	23	20	50
34650.W2103	M20	159	150	189.0	36.0	23	20	50
34650.W2104	M20	159	200	239.0	36.0	23	20	50
34650.W2105	M20	159	250	289.0	36.0	23	20	50
34650.W2400	M24	80	100	136.0	33.0	19	20	40
34650.W2401	M24	80	150	186.0	33.0	19	20	40
34650.W2402	M24	80	200	236.0	33.0	19	20	40
34650.W2403	M24	80	225	261.0	33.0	19	20	40
34650.W2404	M24	100	100	137.0	34.0	20	20	50
34650.W2405	M24	100	150	187.0	34.0	20	20	50
34650.W2406	M24	100	200	237.0	34.0	20	20	50
34650.W2407	M24	100	250	287.0	34.0	20	20	50
34650.W2408	M24	120	100	138.0	35.0	22	20	50
34650.W2409	M24	120	150	188.0	35.0	22	20	50
34650.W2500	M24	120	200	238.0	35.0	22	20	50



Levelling Feet - Fixed Feet

stainless steel, heavy duty



Levelling Feet

Order No.	d ₁	d ₂	l	h ₁	h ₂	h ₃	A/F	Load kN max.
34650.W2501	M24	120	250	288.0	35.0	22	20	50
34650.W2502	M24	159	100	139.0	36.0	23	20	60
34650.W2503	M24	159	150	189.0	36.0	23	20	60
34650.W2504	M24	159	200	239.0	36.0	23	20	60
34650.W2505	M24	159	250	289.0	36.0	23	20	60
34650.W3000	M30	120	100	139.0	36.0	22	26	60
34650.W3001	M30	120	150	189.0	36.0	22	26	60
34650.W3002	M30	120	200	239.0	36.0	22	26	60
34650.W3003	M30	120	250	289.0	36.0	22	26	60
34650.W3004	M30	159	100	140.0	37.0	23	26	70
34650.W3005	M30	159	150	190.0	37.0	23	26	70
34650.W3006	M30	159	200	240.0	37.0	23	26	70
34650.W3007	M30	159	250	290.0	37.0	23	70	70

LEVELLING FEET



A Range of features to suit your application

Product selection

To ensure you select the most suitable levelling feet for your application consider the following questions:

- Tilting or fixed?
- Material required - steel, stainless or plastic?
- Load carrying capacity - light, medium or heavy duty?
(Review the quoted load capacities in the individual product tables).
- Bolt down feature required?
- Threaded or plastic insert required for mounting?
- Optional extras: hygiene seal, rubber pad, (subject to minimum quantity and selected model).

Key types

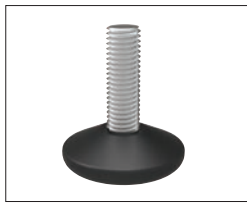

Fixed feet



Articulating levelling feet



Machine mounts



Fulcrum screw

Available features



Articulation



Standard nylon base



Anti-slip base



Bolt down base



Hygienic seal

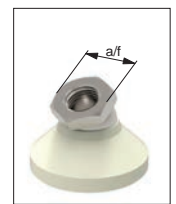

Hex for easy installation

Materials



Steel thread - Nylon base



Stainless thread - Nylon base



Steel thread - Steel base



Stainless thread - Stainless base

Mounting inserts



Weldable insert



Hollow section insert



Hollow section bushed insert

Additional technical information



▶ For applications under greater loads and requiring increased precision of adjustment see our range of Precision Height Adjusters.

▶ For applications exposed to extreme vibrations see our range of Anti-Vibration Mounts.





Mini Levelling Feet

stainless steel, articulated

Levelling Feet

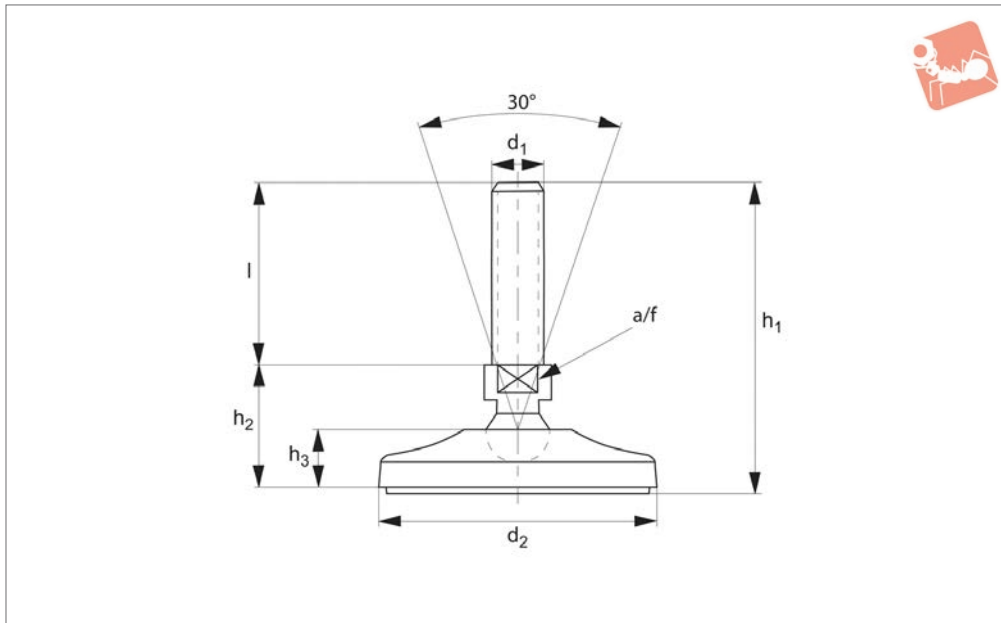

34614

LEVELLING FEET

Material

Stainless steel (AISI 304), with rubber pad (70 Shore A).
Stainless steel (AISI 316) version available

on request.

Technical Notes

Load values refer to static loads, located at

half the screw height.

When vibrations or dynamic loads are present these values should be reduced.

Order No.	d ₁	d ₂	l	h ₁	h ₂	h ₃	A/F	Load kN max.
34614.W0800	M 8	40	25	53	25	14.5	12	10
34614.W0801	M 8	40	50	78	25	14.5	12	10
34614.W0802	M 8	40	75	103	25	14.5	12	10
34614.W0803	M 8	40	100	128	25	14.5	12	10



34615

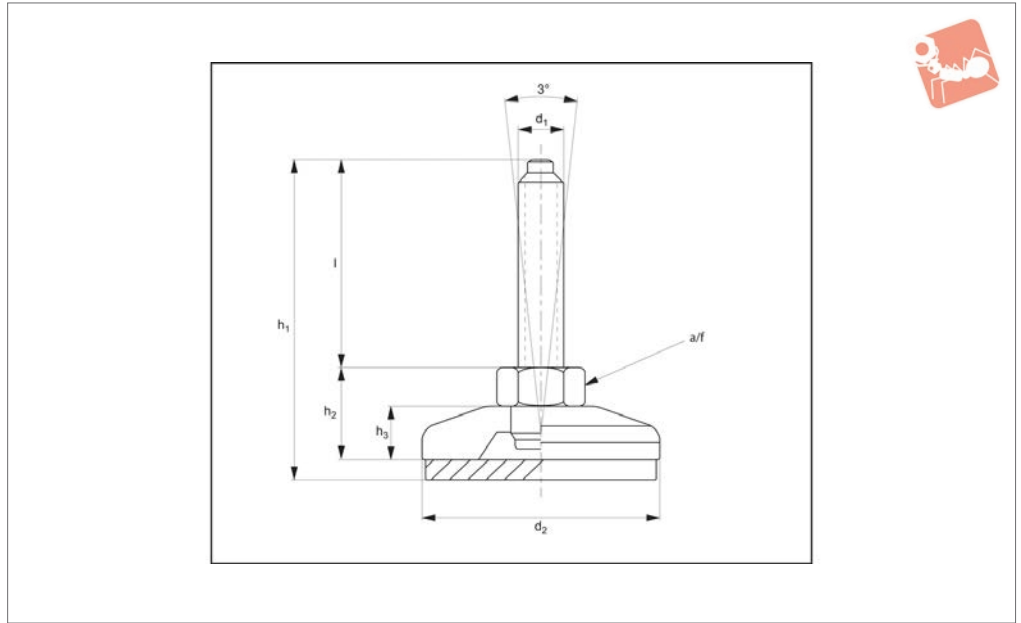

Material

Stainless steel (AISI 304), with rubber pad (70 Shore A).
Stainless steel (AISI 316) version available

on request.

Technical Notes

Load values refer to static loads, located at

half the screw height.

When vibrations or dynamic loads are present these values should be reduced.

Order No.	d ₁	d ₂	l	h ₁	h ₂	h ₃	A/F	Load kN max.
34615.W0800	M 8	40	25	42	14	8	14	9
34615.W0801	M 8	40	50	67	14	8	14	9
34615.W1000	M10	40	25	42	14	8	14	9
34615.W1001	M10	40	50	67	14	8	14	9
34615.W1002	M10	40	75	92	14	8	14	9
34615.W1200	M12	40	50	67	14	8	14	9
34615.W1201	M12	40	100	117	14	8	14	9



Mini Levelling Feet

steel with plastic base

Levelling Feet

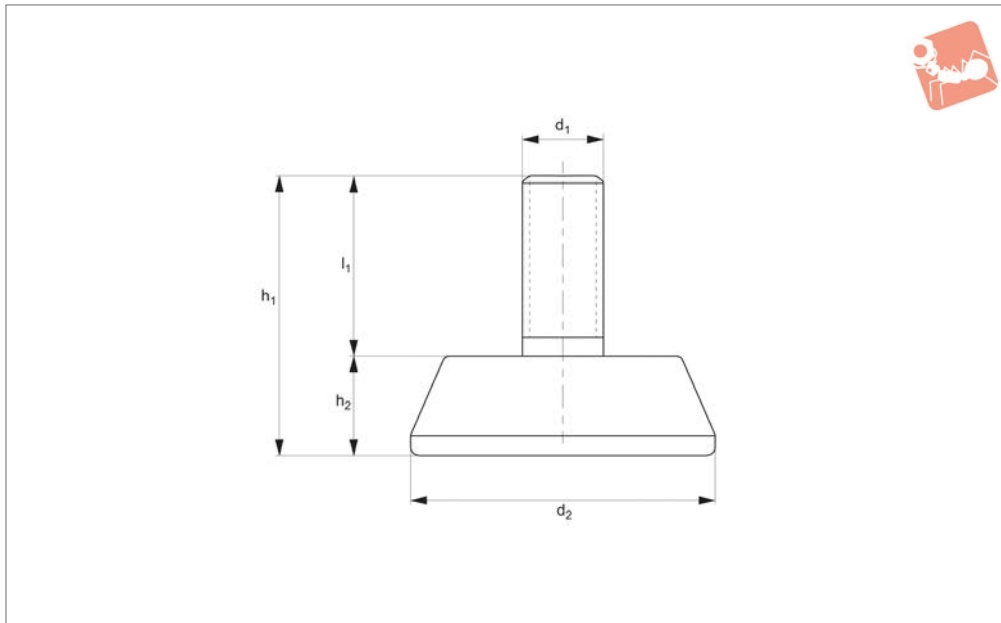

34616

LEVELLING FEET

Material

Galvanised steel stud with plastic base.

calculated at the half of the screw length.

In the presence of vibrations or dynamic loads these values should be reduced.

Technical Notes

Load values shown are for static loads

Order No.	d ₁	d ₂	l ₁	h ₁	h ₂	Static load N
34616.W0800	M 8	30	20	31.5	11.5	2000
34616.W0801	M 8	40	25	39.5	14.5	2500
34616.W0802	M 8	40	25	41.0	16.0	1800
34616.W1000	M10	30	20	31.5	11.5	2000
34616.W1001	M10	40	25	39.5	14.5	2500
34616.W1002	M10	50	35	52.0	17.0	3500
34616.W1003	M10	40	25	41.0	16.0	2250
34616.W1200	M12	50	35	52.0	17.0	3500
34616.W1201	M12	60	35	52.0	17.0	4000
34616.W1202	M12	40	25	41.0	16.0	3150



34618

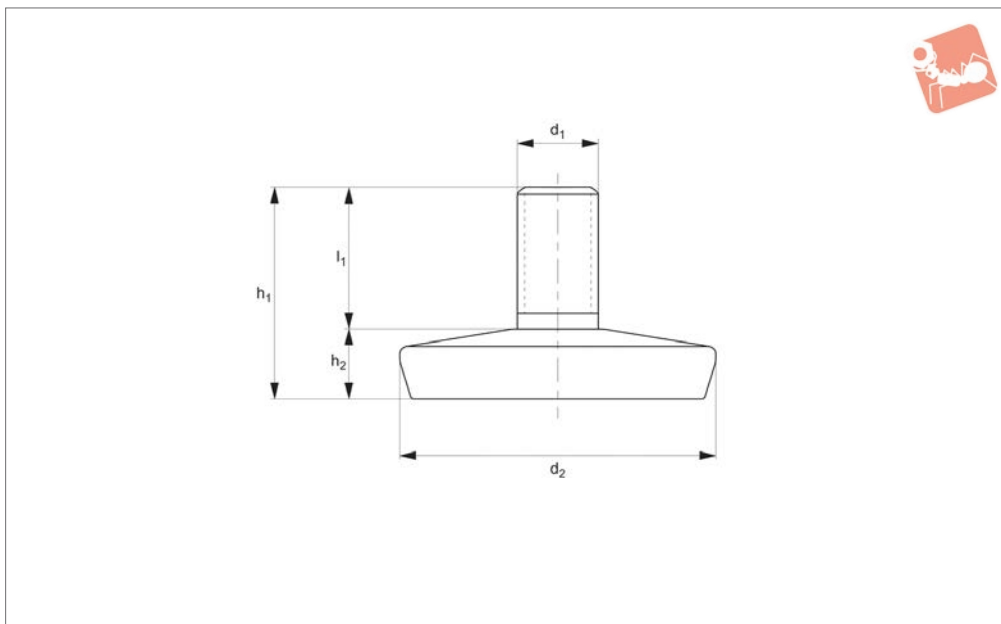

Material

Galvanised steel stud with plastic base.

calculated at the half of the screw length.
In the presence of vibrations or dynamic loads these values should be reduced.

Technical Notes

Load values shown are for static loads

Order No.	d ₁	d ₂	l ₁	h ₁	h ₂	Static load N
34618.W0800	M 8	40	20	30	10	3000
34618.W1000	M10	40	20	30	10	3000



Mini Levelling Feet

steel with hex. plastic base

Levelling Feet

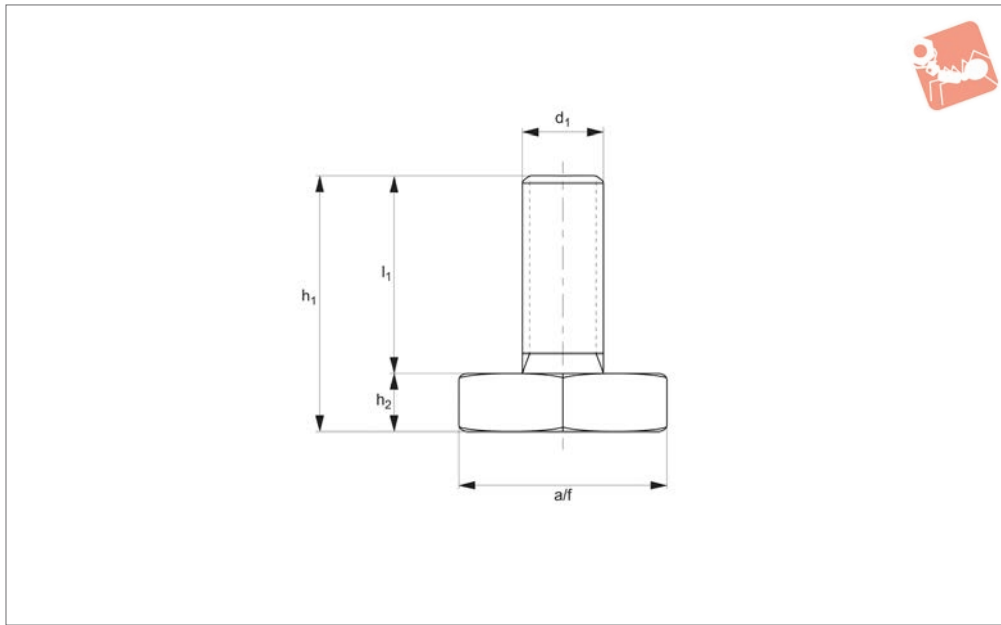

34619

LEVELLING FEET

Material

Galvanised steel stud with hexagon plastic base.

Technical Notes

Load values shown are for static loads calculated at the half of the screw length.

In the presence of vibrations or dynamic loads these values should be reduced.

Order No.	d_1	l_1	h_1	h_2	A/F	Static load N
34619.W0800	M 8	25	33	8	25	2500
34619.W0801	M 8	35	43	8	25	2500
34619.W1000	M10	25	33	8	25	2500
34619.W1001	M10	35	43	8	25	2500



34631

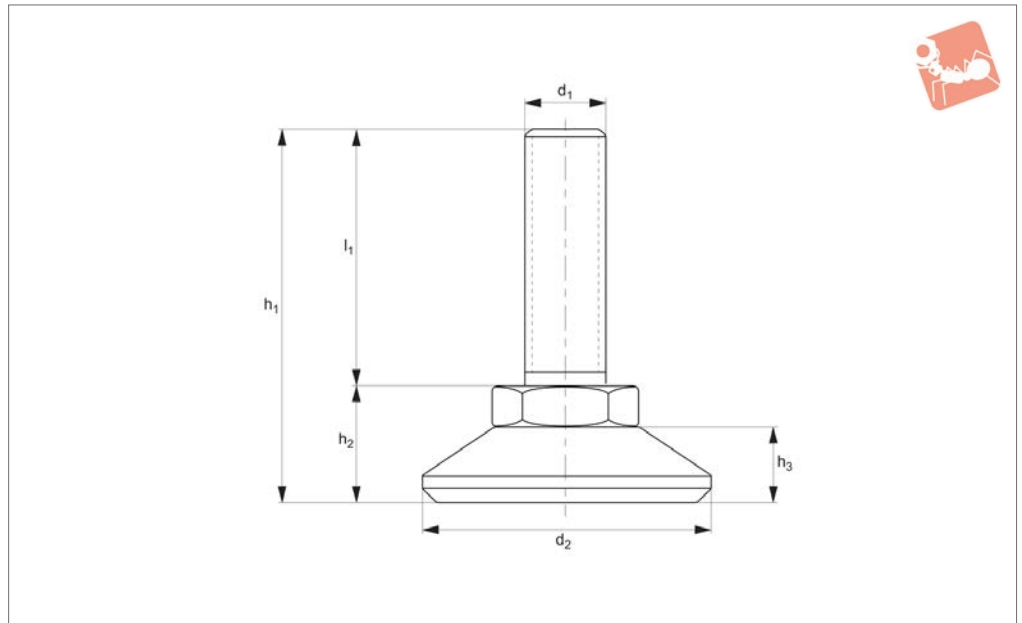

Material

Galvanised steel stud with plastic base.

calculated at the half of the screw length.

In the presence of vibrations or dynamic loads these values should be reduced.

Technical Notes

Load values shown are for static loads

Order No.	d_1	d_2	l_1	h_1	h_2	h_3	Static load N
34631.W1003	M10	40	40	58.0	18.0	11.5	3500
34631.W1004	M10	40	60	78.0	18.0	11.5	3500
34631.W1005	M10	50	40	60.0	20.0	13.5	4500
34631.W1006	M10	50	60	80.0	20.0	13.5	4500
34631.W1000	M10	26	10	26.5	16.5	11.5	1500
34631.W1001	M10	26	20	36.5	16.5	11.5	1500
34631.W1002	M10	26	30	46.5	16.5	11.5	1500



Mini Levelling Feet

steel with plastic base

Levelling Feet

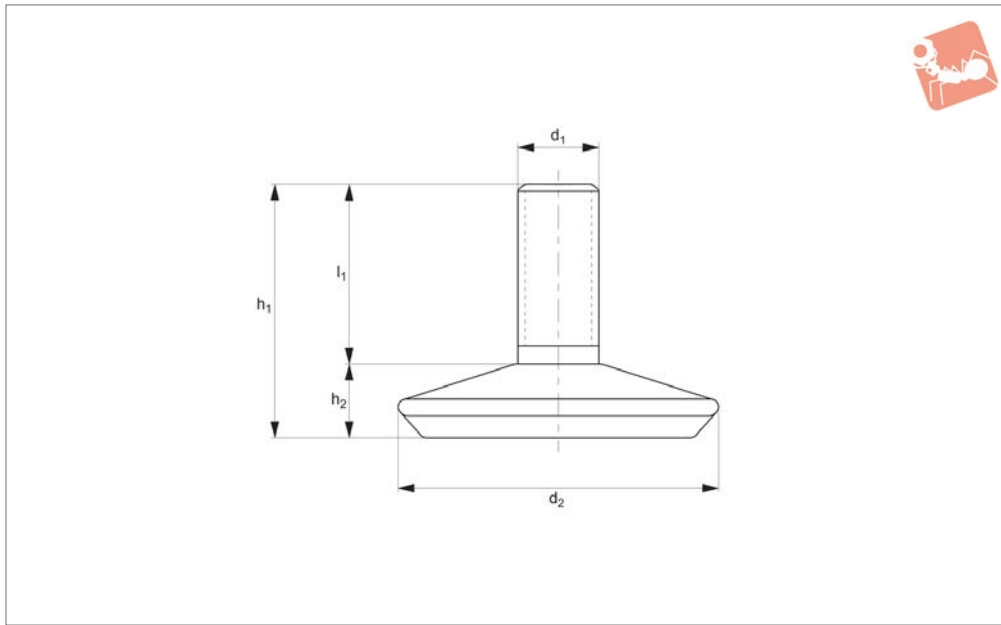

34641

LEVELLING FEET

Material

Galvanised steel stud with plastic base, with chromate case.

Technical Notes

When vibrations or dynamic loads are present these values should be reduced.

Order No.	d ₁	d ₂	l	h ₁	h ₂	Static load N
34641.W0600	M 6	20	13	20.0	7.0	1000
34641.W0800	M 8	25	20	30.0	10.0	1500
34641.W0801	M 8	30	20	31.5	11.5	2000
34641.W0802	M 8	40	25	38.5	13.5	2800
34641.W1000	M10	25	20	30.0	10.0	1500
34641.W1001	M10	30	20	31.5	11.5	2000
34641.W1002	M10	40	25	38.5	13.5	2800
34641.W1003	M10	50	30	45.5	15.5	3800
34641.W1200	M12	50	30	50.5	15.5	3800



34770

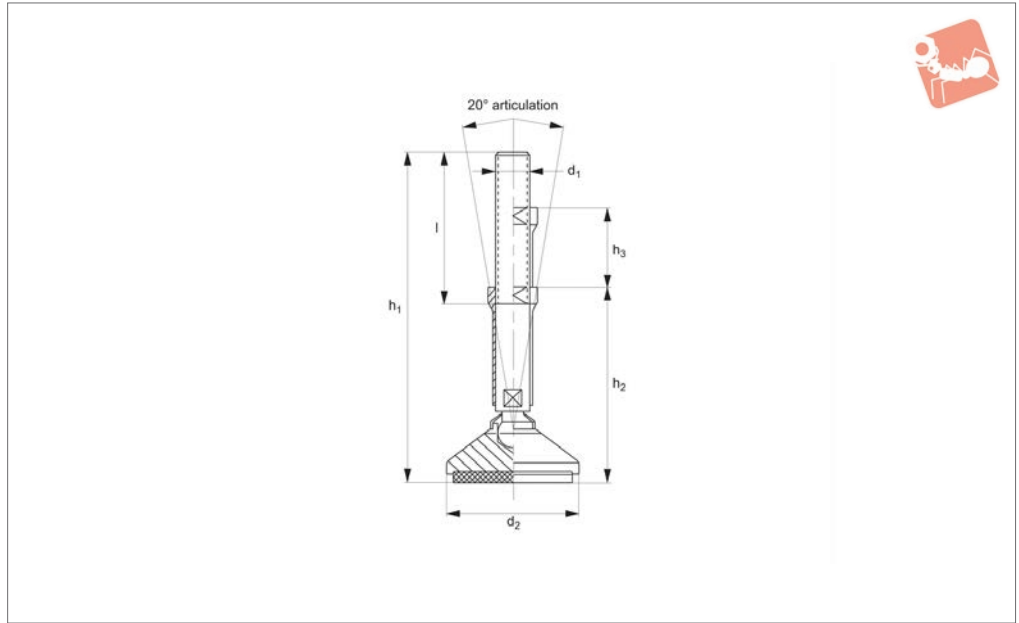

Material

Bolt and shroud nut: AISI 304 stainless steel.

Pad: AISI 304 stainless steel, with inset nitrile pad.

Seal: nitrile rubber.

Technical Notes

Nut shroud is used to cover the exposed

threaded section of the machine mount, and hence prevents areas of contamination. In addition the rubber seal between base and bolt adds to the ease of cleaning.

Tips

Specifically designed for food & drink, pharmaceutical & clean room applications where hygiene is of prime importance and

ingress of materials is to be minimised.

Order No.	d ₁	l	d ₂	h ₁	Height h ₂ min.	Shroud adj. h ₃ max.	Static load kN max.
34770.W0120	M12	68	55	124	70	25	7.5
34770.W0121	M12	92	55	174	95	50	7.5
34770.W0160	M16	68	75	130	75	50	17.5
34770.W0162	M16	92	75	180	100	50	17.5
34770.W0200	M20	68	100	136	85	25	25.0
34770.W0201	M20	92	100	186	110	50	25.0



Hygienic Levelling Feet

stainless steel, with plastic base

Levelling Feet

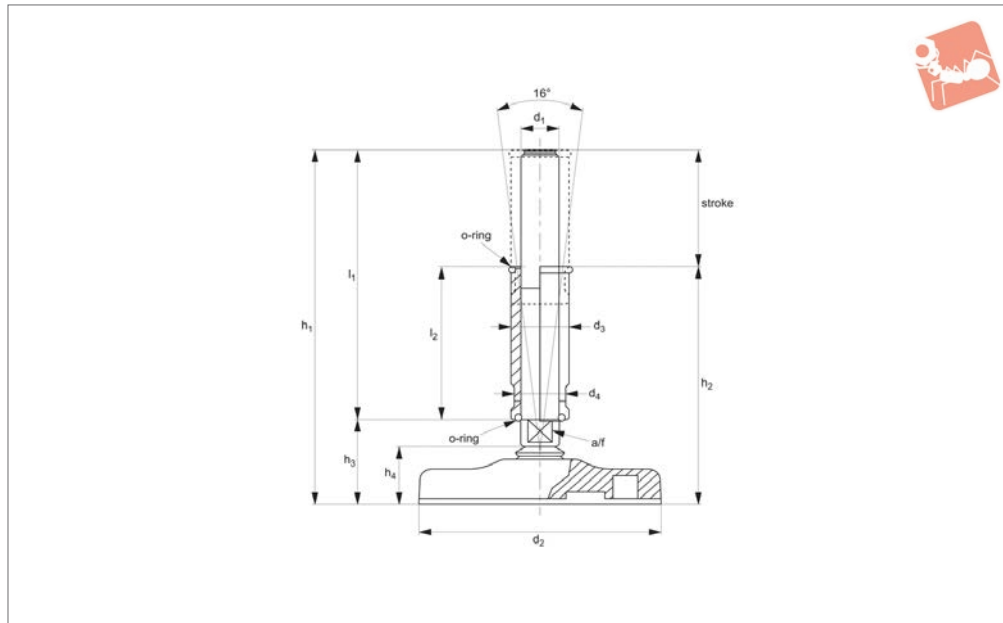

34771

LEVELLING FEET

Material

Base: polyamide base.
Screw: stainless steel 304.

Technical Notes

Nut shroud is used to cover the exposed threaded section of the levelling foot, and hence prevents areas of contamination. In

addition the rubber seal between base and bolt adds to the ease of cleaning.

Load values shown are for static loads calculated at the half of the screw length. In the presence of vibrations or dynamic loads these values should be reduced.

Tips

Specifically designed for food & drink, pharmaceutical & clean room applications where hygiene is of prime importance and ingress of materials is to be minimised.

Order No.	Stroke	d ₁	d ₂	d ₃	d ₄	l ₁	l ₂	h ₁	h ₂	h ₃	A/F	Static load kN
34771.W2000	65mm	M20	103	30	26	150	85	193	128	43	17	20
34771.W2001	65mm	M20	123	30	26	150	85	195	130	45	20	30
34771.W2400	65mm	M24	103	35	30	150	85	194	129	44	17	20
34771.W2401	65mm	M24	123	35	30	150	85	196	131	46	20	30
34771.W3000	65mm	M30	123	42	36	150	85	197	132	47	26	30



34772

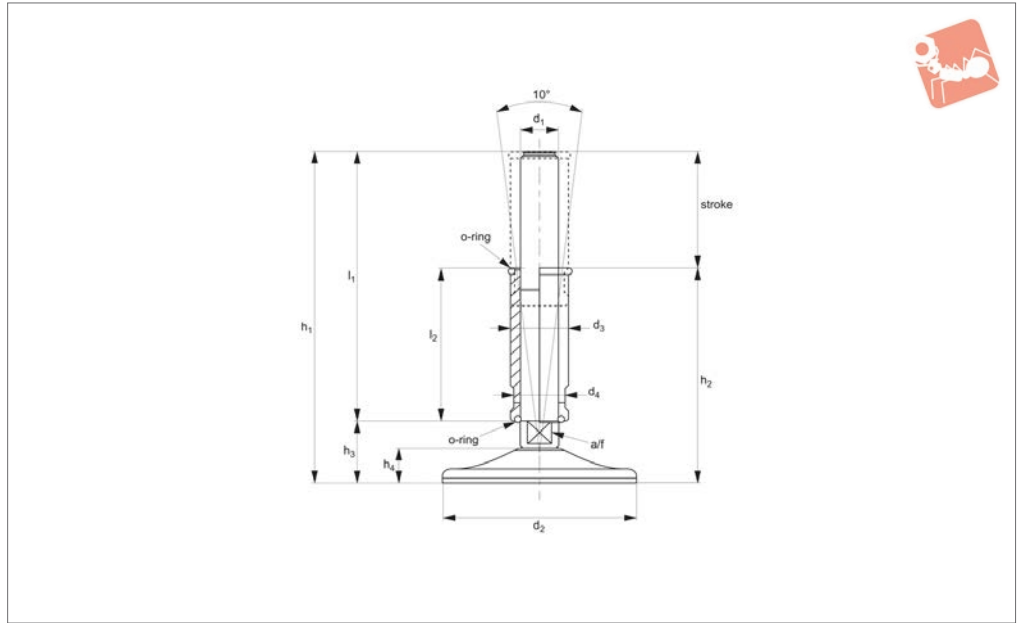

LEVelling FEET

Material

Base: stainless steel with vulcanized rubber pad.

Screw: stainless steel 304.

Technical Notes

Nut shroud is used to cover the exposed threaded section of the levelling feet, and

hence prevents areas of contamination. In addition the rubber seal between base and bolt adds to the ease of cleaning.

Load values shown are for static loads calculated at the half of the screw length. In the presence of vibrations or dynamic

loads these values should be reduced.

Tips

Specifically designed for food & drink, pharmaceutical & clean room applications where hygiene is of prime importance and ingress of materials is to be minimised.

Order No.	Stroke	d ₁	d ₂	d ₃	d ₄	l ₁	l ₂	h ₁	h ₂	h ₃	h ₄	A/F	Static load kN
34772.W1600	40mm	M16	60	24	20	125	65	160	95	35	22.0	17	7
34772.W1601	65mm	M16	60	24	20	150	85	185	120	35	22.0	17	7
34772.W1602	40mm	M16	80	24	20	125	65	163	98	38	22.0	17	10
34772.W1603	65mm	M16	80	24	20	150	85	188	123	38	25.0	17	10
34772.W1604	65mm	M16	100	24	20	150	85	193	128	43	25.0	17	15
34772.W1605	65mm	M16	120	24	20	150	85	195	130	45	25.0	17	30
34772.W1606	40mm	M16	75	24	20	125	65	153	88	28	25.0	13	20
34772.W1607	65mm	M16	100	24	20	150	85	187	122	37	30.0	17	30
34772.W2000	65mm	M20	60	30	26	150	85	185	120	35	30.0	17	7
34772.W2001	65mm	M20	80	30	26	150	85	188	123	38	30.0	17	10
34772.W2002	65mm	M20	80	30	26	200	85	238	173	38	30.0	17	10
34772.W2003	65mm	M20	100	30	26	150	85	193	128	43	30.0	17	15
34772.W2004	65mm	M20	100	30	26	200	85	243	178	43	30.0	17	15
34772.W2005	65mm	M20	120	30	26	150	85	195	130	45	30.0	17	30
34772.W2006	65mm	M20	120	30	26	200	85	245	180	45	32.0	17	30
34772.W2007	65mm	M20	100	30	26	150	85	187	122	37	32.0	17	30
34772.W2008	65mm	M20	100	30	26	200	85	237	172	37	32.0	17	30
34772.W2009	65mm	M20	120	30	26	150	85	187	122	37	32.0	17	40
34772.W2010	65mm	M20	120	30	26	200	85	237	172	37	32.0	17	40
34772.W2011	65mm	M20	150	30	26	150	85	189	124	39	32.0	17	50
34772.W2012	65mm	M20	150	30	26	200	85	239	174	39	32.0	17	50
34772.W2400	65mm	M24	100	35	30	150	85	194	129	44	18.0	20	15
34772.W2401	65mm	M24	100	35	30	200	85	244	179	44	22.0	20	15
34772.W2402	65mm	M24	120	35	30	150	85	196	131	46	22.0	20	30
34772.W2403	65mm	M24	120	35	30	200	85	246	181	46	22.0	20	30
34772.W2404	65mm	M24	100	35	30	150	85	188	123	38	22.0	20	30
34772.W2405	65mm	M24	100	35	30	200	85	238	173	38	22.0	26	30
34772.W2406	65mm	M24	120	35	30	150	85	188	123	38	22.0	20	40
34772.W2407	65mm	M24	120	35	30	200	85	238	173	38	22.0	20	40
34772.W2408	65mm	M24	150	35	30	150	85	190	125	40	22.0	20	50



Hygienic Levelling Feet

stainless steel, with rubber pad



Levelling Feet

Order No.	Stroke	d ₁	d ₂	d ₃	d ₄	l ₁	l ₂	h ₁	h ₂	h ₃	h ₄	A/F	Static load kN
34772.W2409	65mm	M24	150	35	30	200	85	240	175	40	22.0	20	50
34772.W3000	65mm	M30	100	42	36	150	85	195	130	45	22.0	26	15
34772.W3001	65mm	M30	100	42	36	200	85	245	180	45	22.0	26	15
34772.W3002	65mm	M30	120	42	36	150	85	197	132	47	22.0	26	30
34772.W3003	65mm	M30	120	42	36	200	85	247	182	47	22.0	26	30
34772.W3004	65mm	M30	100	42	36	150	85	189	124	39	24.5	26	30
34772.W3005	65mm	M30	100	42	36	200	85	239	174	39	24.5	26	30
34772.W3006	65mm	M30	120	42	36	150	85	189	124	39	24.5	26	40
34772.W3007	65mm	M30	120	42	36	200	85	239	174	39	24.5	26	40
34772.W3008	65mm	M30	150	42	36	150	85	191	126	41	24.5	26	50
34772.W3009	65mm	M30	150	42	36	200	85	241	176	41	24.5	26	50

LEVELLING FEET



34775

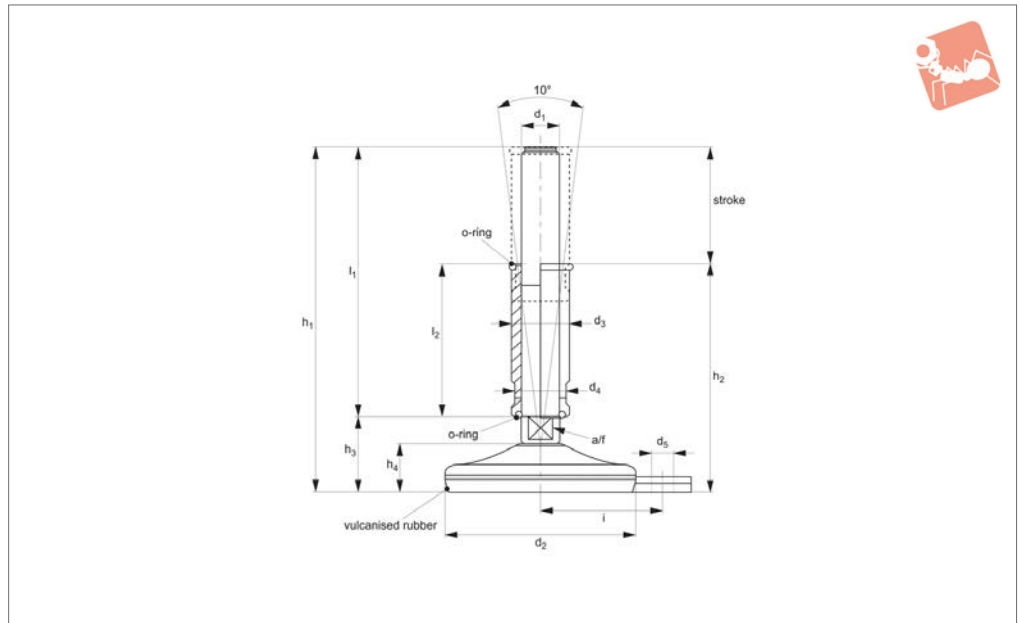

Material

Base: stainless steel 304 with vulcanized rubber pad.

Screw: stainless steel 304.

Technical Notes

Nut shroud is used to cover the exposed threaded section of the levelling feet, and

hence prevents areas of contamination. In addition the rubber seal between base and bolt adds to the ease of cleaning.

Load values shown are for static loads calculated at the half of the screw length. In the presence of vibrations or dynamic

loads these values should be reduced.

Tips

Specifically designed for food & drink, pharmaceutical & clean room applications where hygiene is of prime importance and ingress of materials is to be minimised.

Order No.	Stroke	d ₁	d ₂	d ₃	d ₄	l ₁	l ₂	h ₁	h ₂	h ₃	h ₄	i	A/F	Static load kN
34775.W1600	40mm	M16	60	24	20	125	65	160	95	35	22	45	17	7
34775.W1601	65mm	M16	60	24	20	150	85	185	120	35	22	45	17	7
34775.W1602	40mm	M16	80	24	20	125	65	163	98	38	25	54	17	10
34775.W1603	65mm	M16	80	24	20	150	85	188	123	38	25	54	17	10
34775.W1604	65mm	M16	100	24	20	150	85	193	128	43	30	69	17	15
34775.W2000	65mm	M20	60	30	26	150	85	185	120	35	22	45	17	7
34775.W2001	65mm	M20	80	30	26	150	85	188	123	38	25	54	17	10
34775.W2002	65mm	M20	80	30	26	200	85	238	173	38	25	54	17	10
34775.W2003	65mm	M20	100	30	26	150	85	193	128	43	30	69	17	15
34775.W2004	65mm	M20	100	30	26	200	85	243	178	43	30	69	17	15
34775.W2400	65mm	M24	100	35	30	150	85	194	129	44	30	69	20	15
34775.W2401	65mm	M24	100	35	30	200	85	244	179	44	30	69	20	15
34775.W3000	65mm	M30	100	42	36	150	85	195	130	45	30	69	26	15
34775.W3001	65mm	M30	100	42	36	200	85	245	180	45	30	69	26	15

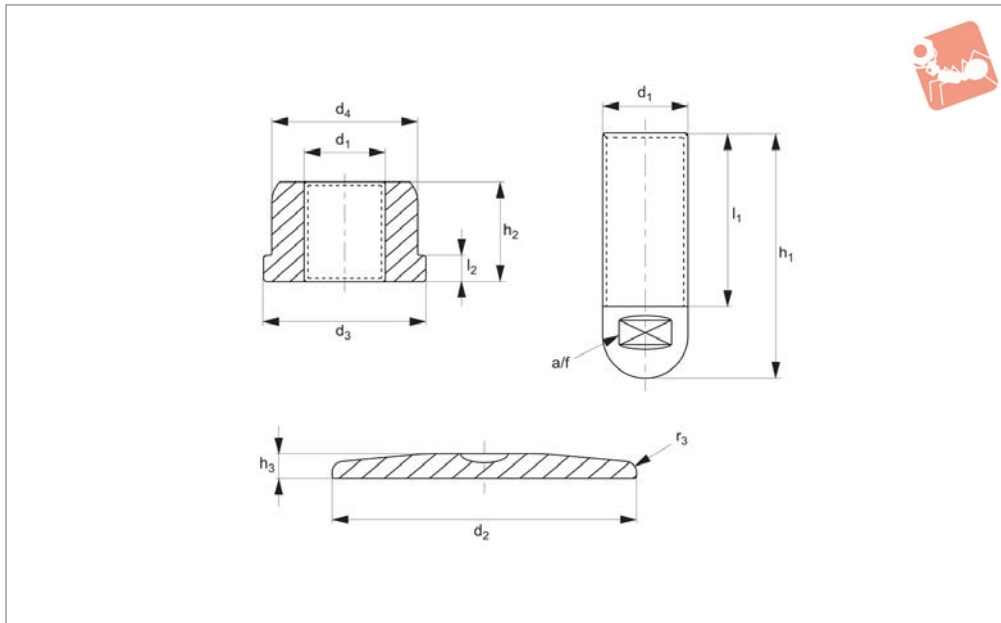

34777

LEVELLING FEET

Material

Stainless steel 304

pharmaceutical and food industry in respect of the strictest hygienic regulations.

calculated at the half of the screw length. In the presence of vibrations or dynamic loads these values should be reduced.

Technical Notes

Levelling system planned for dairy, phar-

Load values shown are for static loads

Order No.	d ₁	d ₂	d ₃	d ₄	l ₁	l ₂	h ₁	h ₂	h ₃	A/F	Static load kN
34777.W2000	M20	80	60	54	70	8	100	25	10	17	35
34777.W2400	M24	100	60	54	70	10	100	40	10	20	70
34777.W3000	M30	120	60	54	70	10	100	40	10	26	80
34777.W3001	M30	120	80	75	100	10	140	25	10	26	80
34777.W4000	M40	150	60	54	100	10	140	50	15	36	120
34777.W4001	M40	200	60	54	100	10	140	50	15	36	120



34778

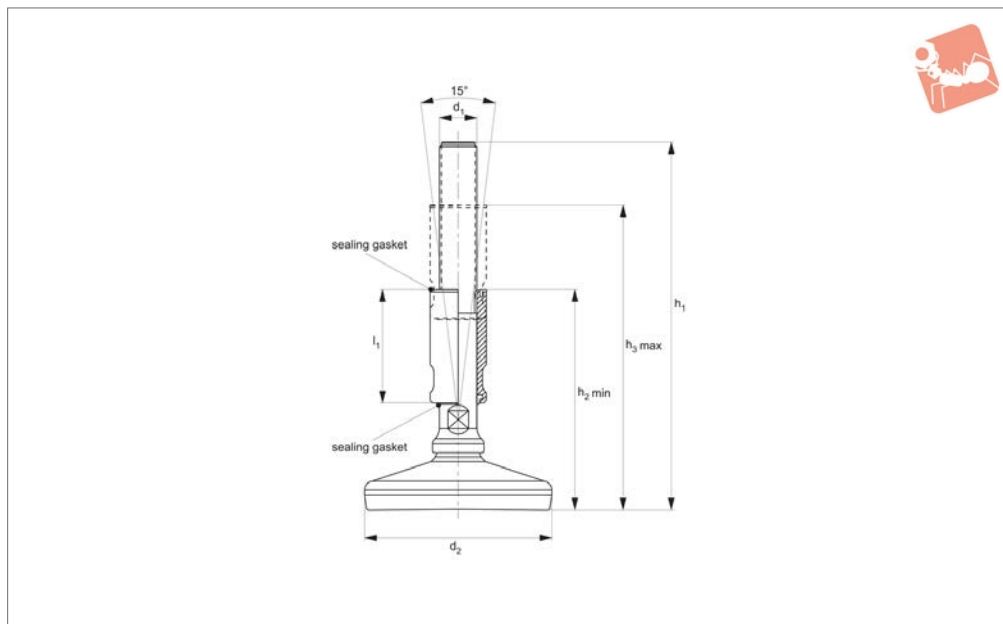

Material

Stainless steel AISI 304.
Blue gasket: silicone.
Pad: vulcanised nitrile rubber.

Technical Notes

Nut shroud is used to cover the exposed threaded section of the machine mount,

and hence prevents contamination. Use a spanner to adjust this shroud height h_2 and h_3 , using spanner size detailed in the table.

Tips

Made to the high „3A“ standard. This ensures it meets the high standards

required for use in food, beverage, pharmaceutical and medical applications. Hygienically designed for effective and easy cleaning, corrosion resistant, non-toxic. Design precludes contamination by dirt, food particles and organic matter.

Order No.	d_1	d_2	l_1	h_1	For spanner size	Shroud adj. h_2 min.	Shroud adj. h_3 max.	Static load kN max.
34778.W1620	M16	120	60	200	13	121	166	30
34778.W1625	M16	120	85	250	13	146	216	30
34778.W2020	M20	120	60	200	17	121	166	30
34778.W2025	M20	120	85	250	17	146	216	30
34778.W2420	M24	120	60	200	20	121	166	30
34778.W2425	M24	120	85	250	20	146	216	30

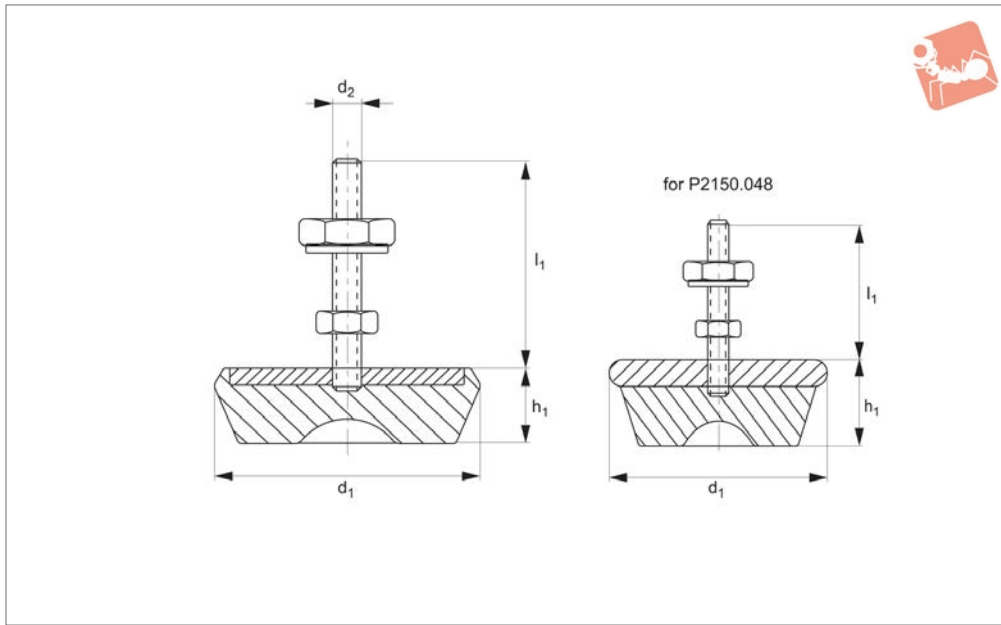

34900

MACHINE MOUNTS

Material

Steel body with silver zinc plated thread.
Synthetic rubber pad (65-70 Shore A) with

anti-slide cavity.

vibrations and for irregular floors.

Technical Notes

Suitable for machinery with low frequency

Order No.	d ₁	h ₁	d ₂	l ₁	Load range kgf
34900.W0048	48	23	M 8	40	0-80
34900.W0060	60	25	M10	83	50-120
34900.W0075	75	30	M12	90	80-150
34900.W0090	90	33	M12	90	120-300
34900.W0105	105	38	M16	110	250-500
34900.W0125	125	45	M16	110	400-800
34900.W0150	150	55	M16	110	600-1000
34900.W0170	170	57	M16	110	1000-1600
34900.W0187	187	70	M20	115	1400-2400
34900.W0210	210	75	M20	115	2000-3500

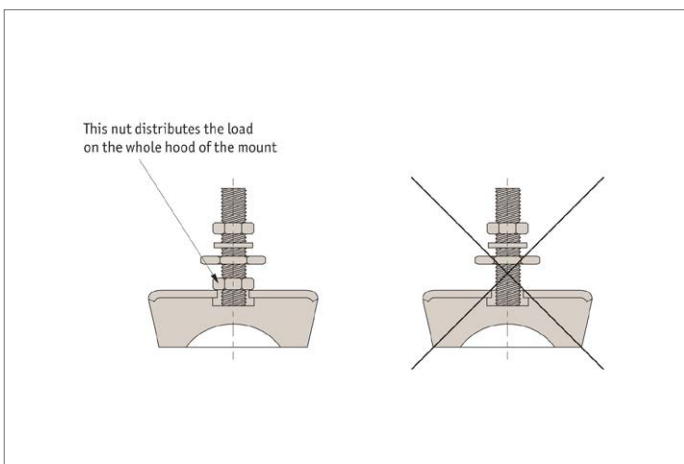

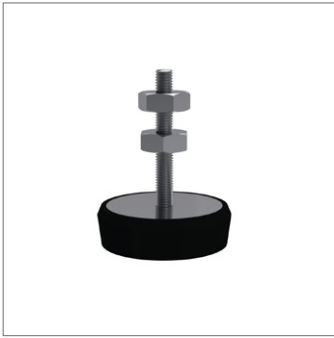

34910

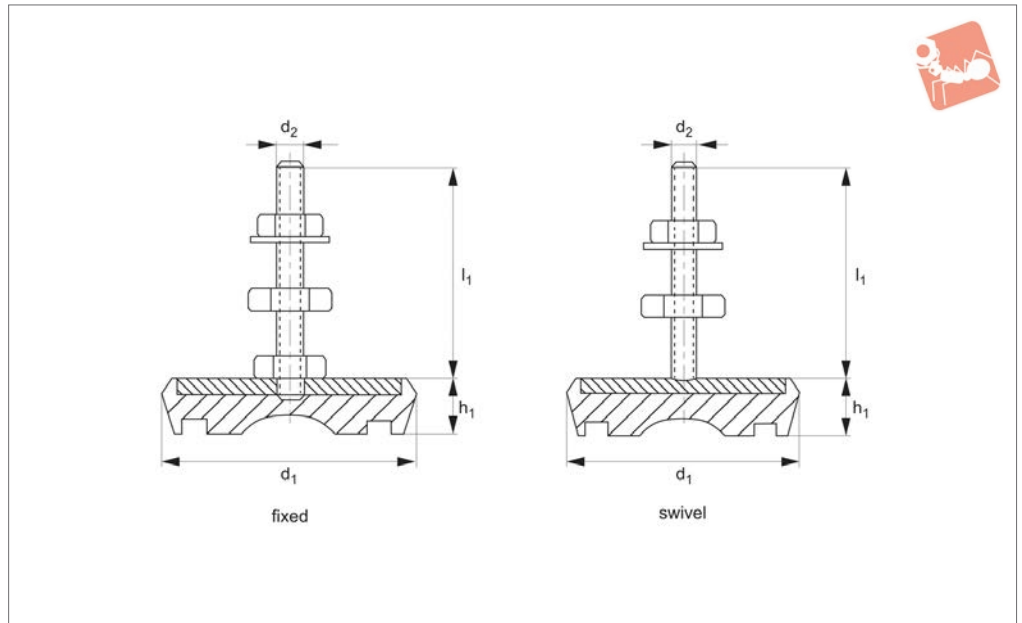

Material

Steel body with zinc plated thread.
Synthetic rubber base (65 Shore A), with anti-slide cavity.

Technical Notes

Suitable for medium and high frequency

vibrations and with smooth floors.

Tips

For inclined floors use the swivel base versions (M12 and M16).
The swivel base versions have a separate screw which rests in the concave cup on the

top portion of the foot body.

Order No.	Style	d_1	h_1	d_2	l_1	Load range kgf
34910.W0040	Fixed	40	15	M 8	40	0-60
34910.W0063	Fixed	63	18	M10	83	30-100
34910.W0070	Fixed	70	22	M12	90	80-150
34910.W0090	Fixed	90	25	M12	90	100-350
34910.W0106	Fixed	106	29	M16	110	300-600
34910.W0127	Fixed	127	33	M16	110	500-900
34910.W0150	Fixed	150	39	M16	110	800-1500
34910.W0170	Fixed	170	42	M16	110	1300-2000
34910.W0370	Swivel	70	22	M12	90	80-150
34910.W0390	Swivel	90	26	M12	90	100-350
34910.W0406	Swivel	106	32	M16	110	300-600
34910.W0427	Swivel	127	33	M16	110	500-900
34910.W0450	Swivel	150	39	M16	110	800-1500
34910.W0470	Swivel	170	42	M16	110	1300-2000

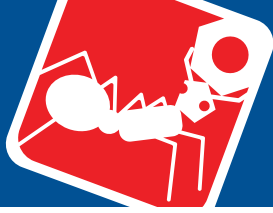

Heavy Duty Machine Mounts

polyurethane base

Machine Mounts

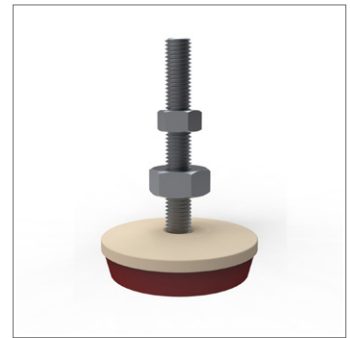
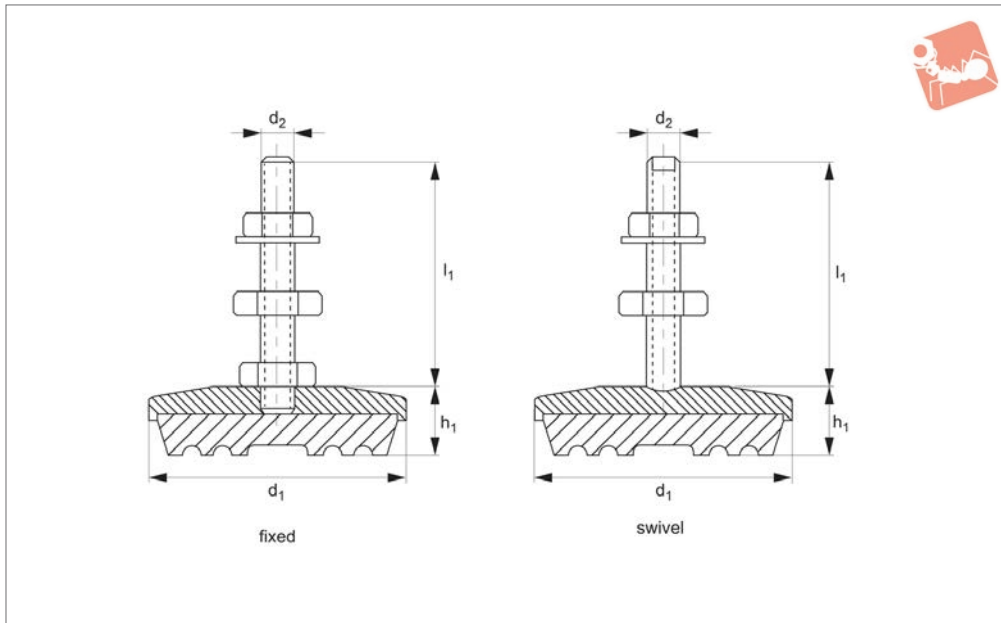

34930

MACHINE MOUNTS

Material

Steel (GGG-40) coated body with zinc plated thread. Polyurethane base (65-90 Shore A).

deflection and maximum adherence due to shape of base.

Resistant to water, oil, high and low temperatures, abrasions and shocks.

tions where there is high risk of deterioration due to oil and other substances.

Also available in stainless steel - see product number 34990.

Technical Notes

High resistance machine mounts, little

Tips

Suitable for heavy machining and condi-

Order No.	Style	d ₁	h ₁	d ₂	l ₁	Load range kgf
34930.W0065	Fixed	65	22	M12	90	200-800
34930.W0100	Fixed	100	30	M16	110	800-2000
34930.W0120	Fixed	120	33	M20	120	2000-4000
34930.W0180	Fixed	180	40	M20	115	4000-6000
34930.W0217	Fixed	217	52	M24	145	5000-10000
34930.W0400	Swivel	100	30	M16	95	500-2000
34930.W0420	Swivel	120	33	M20	120	2000-4000
34930.W0480	Swivel	180	40	M20	130	4000-6000
34930.W0617	Swivel	217	52	M24	150	5000-10000



34980

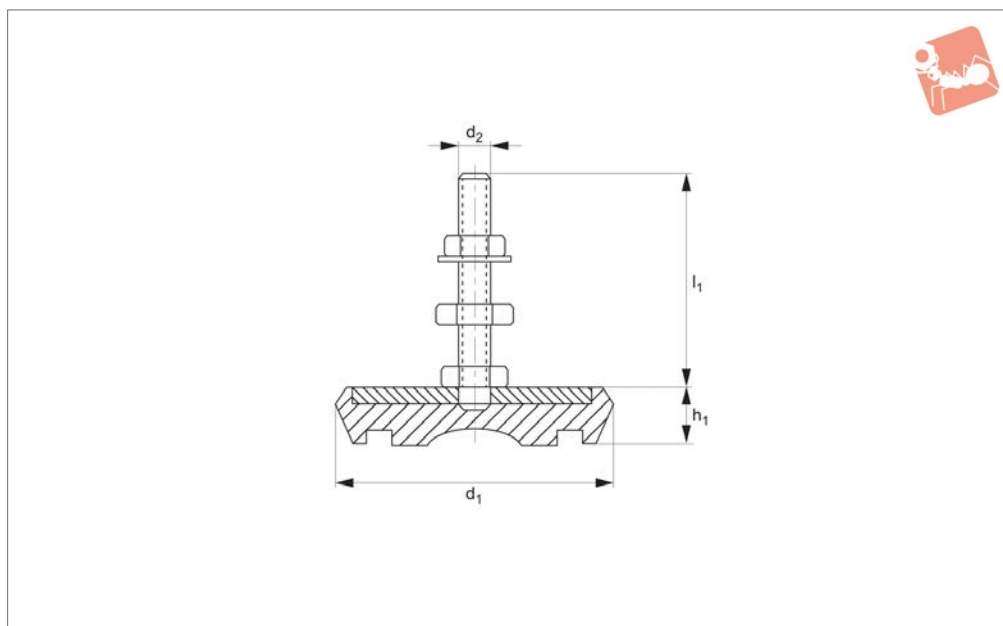

Material

Stainless steel body and thread (A2, AISI 304), with rubber base (65 Shore A).

Technical Notes

Suitable for medium and high frequency vibrations and with smooth floors.

Order No.	d_1	h_1	d_2	l_1	Load range kgf
34980.W0040	40	15	M 8	40	0-60
34980.W0063	63	18	M10	83	30-100
34980.W0070	70	22	M12	90	80-150
34980.W0090	90	25	M12	90	100-350
34980.W0106	106	29	M16	110	300-600
34980.W0127	127	33	M16	110	500-900
34980.W0150	150	39	M16	110	800-1500
34980.W0170	170	42	M16	110	1300-2000



Stainless Machine Mounts

polyurethane base

Machine Mounts

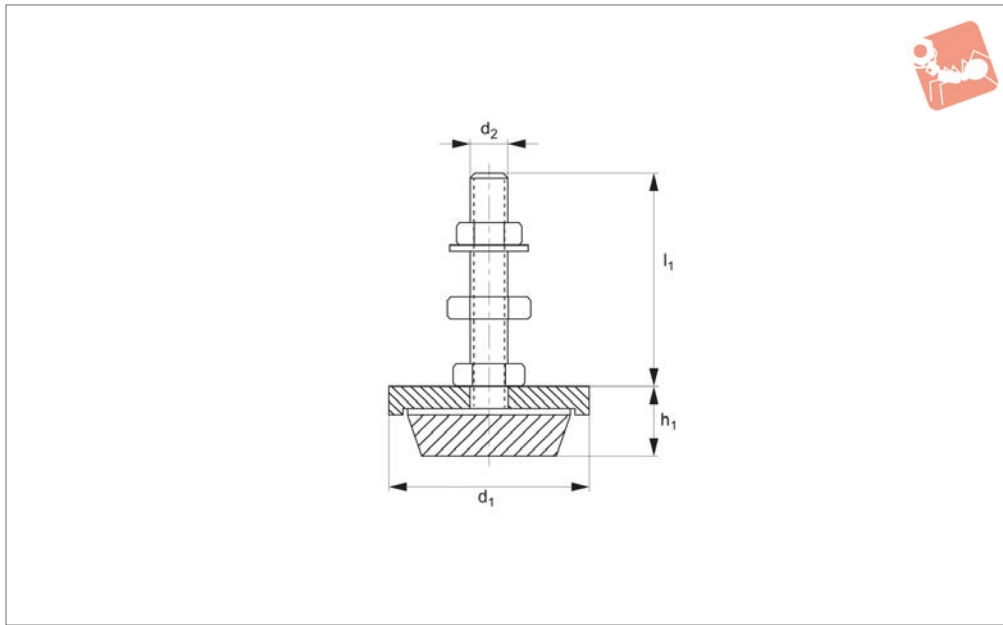

34990

MACHINE MOUNTS

Material

Stainless steel body and thread (A2, AISI 304), with hard polyurethane base (80 Shore A).

Technical Notes

Ideally suited for food and pharmaceutical

applications. The hard polyurethane base is resistant to aggressive oils and chemicals.

Tips

The polyurethane base 80 Shore A also ensures very heavy load carrying capacity.

Order No.	d ₁	h ₁	d ₂	l ₁	Load range kgf
34990.W0120	120	33	M16	110	2000-4000

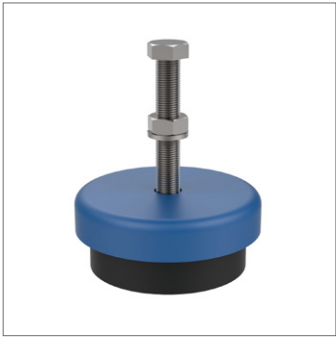

34940

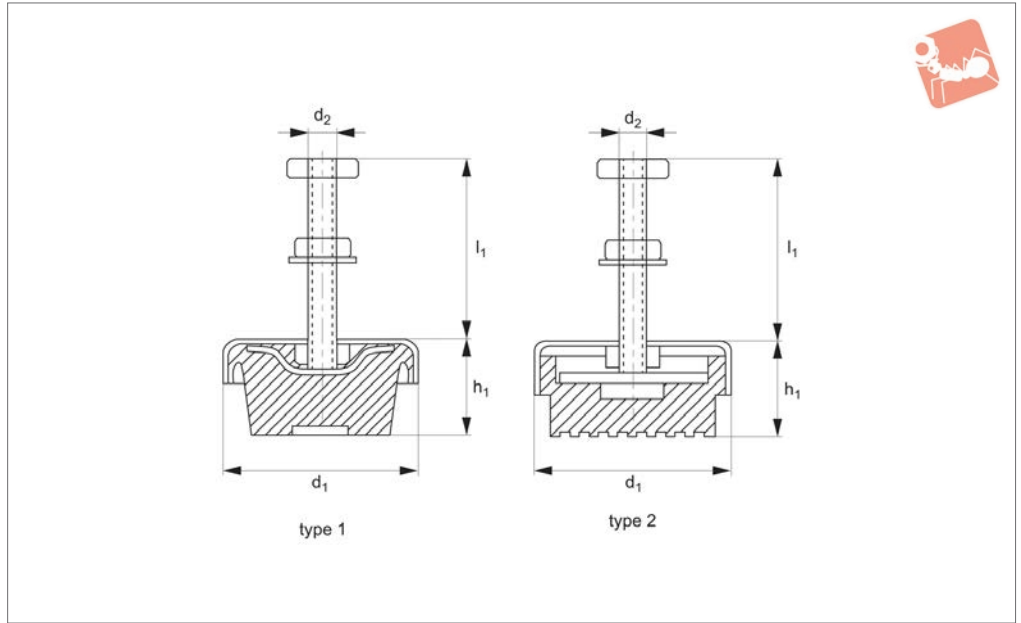

Material

Coated steel body with special bowl shape to protect against corrosion. Synthetic rubber base (75 Shore A).

Technical Notes

Provides long life and outstanding stability.

Great adherence to the floor, due to excellent grip property. Quick and easy to install - for machine levelling.

Tips

Suitable for heavy machinery with strong vibration/impact such as plastic injection

moulding machines, presses, guillotines etc.

Order No.	Type	d ₁	h ₁	d ₂	l ₁	Load range kgf
34940.W0050	Type 1	50	24	M 8	40	0-100
34940.W0075	Type 1	75	35	M10	65	100-350
34940.W0085	Type 2	85	40	M12	80	350-600
34940.W0090	Type 2	90	49	M16	100	600-900
34940.W0125	Type 2	125	52	M16	115	1000-2500
34940.W0170	Type 2	170	57	M20	110	2500-4000

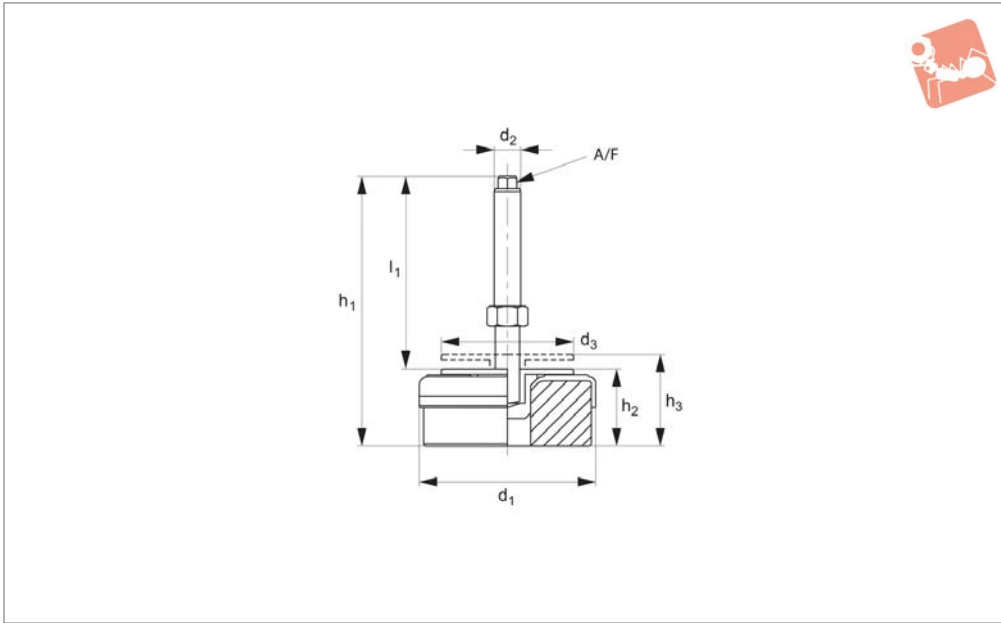

34950

MACHINE MOUNTS

Material

Galvanized steel, with rubber pad (90 Shore A).

Technical Notes

Provides great levelling accuracy, with its

fine pitch thread. Can take very high horizontal loads.

Tips

Suitable for heavy machinery with strong vibration/impacts, such as plastic injection

moulding machines, presses, guillotines etc. Do not raise higher than the max height (h_3).

Order No.	d_1	h_1	d_2	d_3	l_1	h_2	h_3	A/F	Dynamic load kgf	Static load kgf
34950.W0080	80	130	M12x1,25	54	90	40	50	8	250	500
34950.W0120	120	130	M16x1,5	80	85	45	58	12	400	1000
34950.W0160	160	190	M20x1,5	102	136	54	68	15	900	2000
34950.W0200	200	195	M20x1,5	102	136	60	75	15	1500	3500

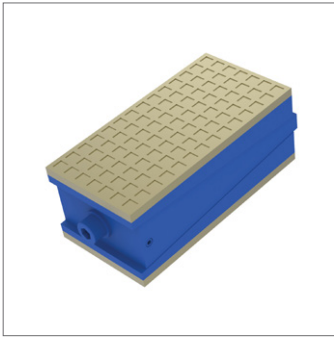

34960

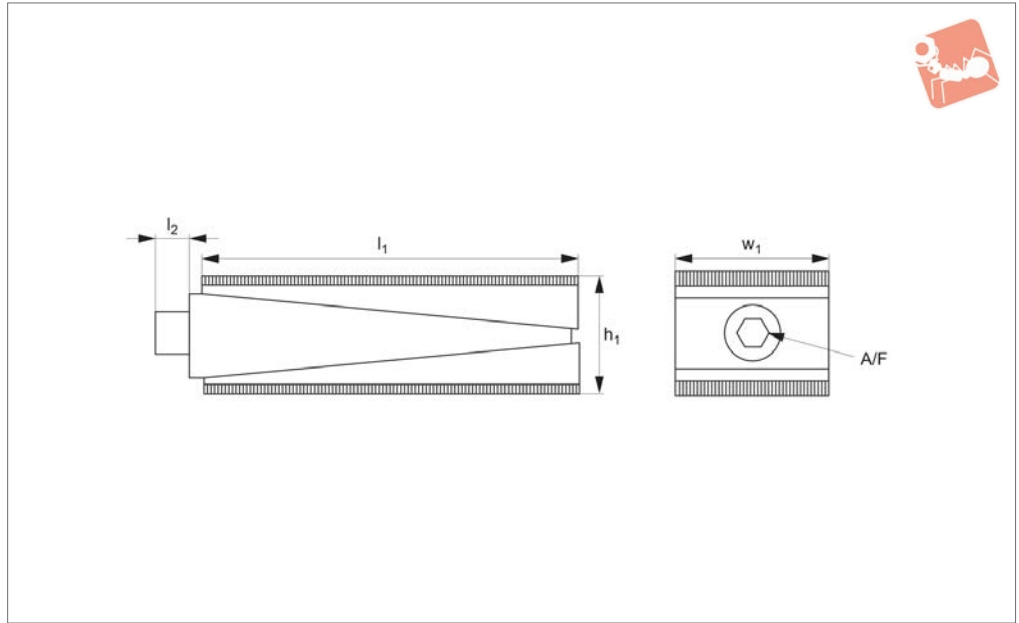

Material

Cast body, coated, with rubber base (65 Shore A) or harder polyurethane base (90 Shore A).

heavy loads. Adjustment by means of allen key on side.
Adjustment is $\pm 5\text{mm}$ or $\pm 10\text{mm}$ depending on version selected - see table.

Tips

The rubber base versions have lower load carrying capacity but are less expensive than the polyurethane versions.
Studded version available on the website.

Technical Notes

For leveling and vibration dampening of

Order No.	h_1	l_1	w_1	l_2	A/F	Base material	Load range kgf
34960.W0150	60 ± 5	150	75	12	12	Rubber	500 - 1000
34960.W0151	60 ± 5	150	75	12	12	Polyurethane	700 - 2500
34960.W0220	70 ± 10	200	100	12	12	Rubber	1500 - 3000
34960.W0221	70 ± 10	200	100	12	12	Polyurethane	3000 - 6000



Weldable Threaded Insert

stainless steel

Threaded Frame Inserts

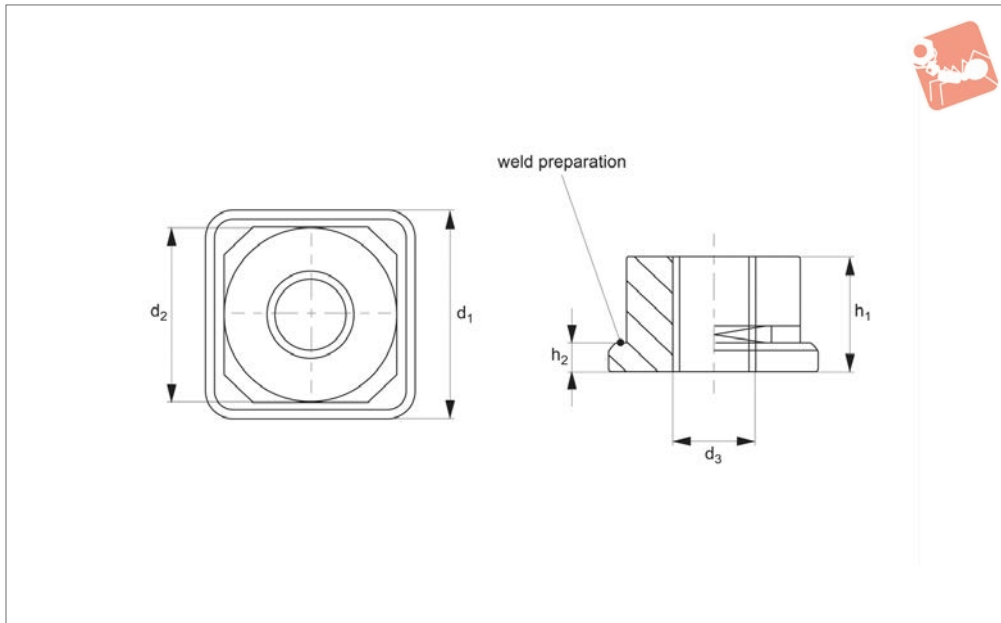

34670

THREADED FRAME INSERTS

Material

Stainless steel AISI 303.

Technical Notes

Ideal for fixing levelling feet to boxed section.

Order No.	Section size	Outerbox d ₁ (sq)	Innerbox d ₂	d ₃	h ₁	h ₂	Load capacity for static load kg max.
34670.W0030	30x30x2,0	30	26	M12	12	4	1500
34670.W0032	30x30x3,0	30	24	M12	12	4	1500
34670.W0033	30x30x3,0	30	24	M16	16	4	2000
34670.W0040	40x40x2,0	40	36	M16	16	5	2000
34670.W0041	40x40x2,0	40	36	M20	20	5	3000
34670.W0042	40x40x3,0	40	34	M16	16	5	2000
34670.W0043	40x40x3,0	40	34	M20	20	5	3000
34670.W0050	50x50x2,0	50	46	M16	16	6	2000
34670.W0051	50x50x2,0	50	46	M20	20	6	3000
34670.W0053	50x50x3,0	50	44	M16	16	6	2000
34670.W0054	50x50x3,0	50	44	M20	20	6	3000
34670.W0055	50x50x3,0	50	44	M24	24	6	4000





34680

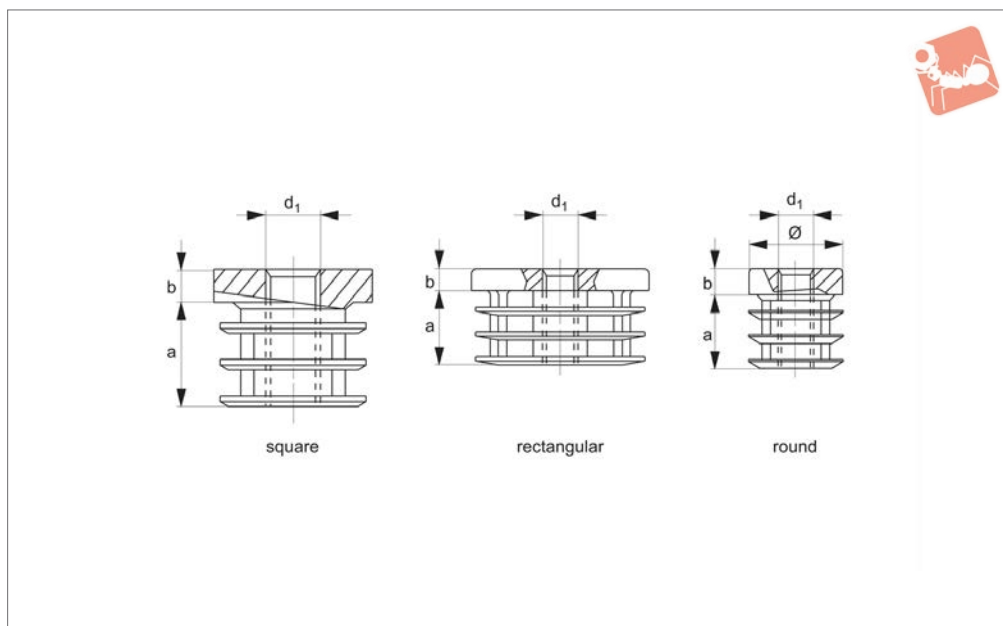

Material

Thermoplastic, black. Moulded thread.

Tips

M 8 available on request, subject to minimum order quantity.

Technical Notes

For use with fixed feet.

Order No.	Type	Tube size mm	d ₁	a	b
34680.W0015	Square	15x15	M 8	18	5
34680.W0016	Square	16x16	M 8	18	5
34680.W0018	Square	18x18	M10	18	5
34680.W0020	Square	20x20	M10	18	5
34680.W0022	Square	22x22	M10	18	5
34680.W0025	Square	25x25	M10	19	5
34680.W0030	Square	30x30	M10	20	6
34680.W0035	Square	35x35	M10	21	6
34680.W0040	Square	40x40	M10	22	6
34680.W0050	Square	50x50	M10	30	6
34680.W0130	Rectangular	20x30	M10	19	6
34680.W0135	Rectangular	20x35	M10	18	6
34680.W0140	Rectangular	20x40	M10	19	6
34680.W0150	Rectangular	20x50	M10	19	6
34680.W0160	Rectangular	20x60	M10	19	6
34680.W0170	Rectangular	25x50	M10	22	6
34680.W0218	Round	Ø 18	M10	18	6
34680.W0220	Round	Ø 20	M10	18	6
34680.W0222	Round	Ø 22	M10	19	6
34680.W0225	Round	Ø 25	M10	19	6
34680.W0228	Round	Ø 28	M10	19	6
34680.W0230	Round	Ø 30	M10	19	6
34680.W0232	Round	Ø 32	M10	19	6
34680.W0235	Round	Ø 35	M10	20	6
34680.W0240	Round	Ø 40	M10	21	6
34680.W0250	Round	Ø 50	M10	21	6



Threaded Plastic Insert

square & round inserts

Threaded Frame Inserts

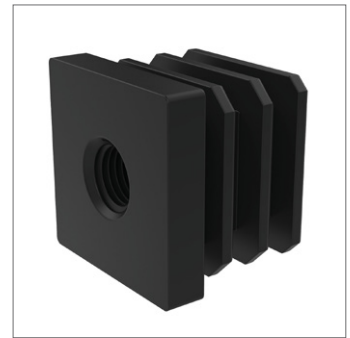
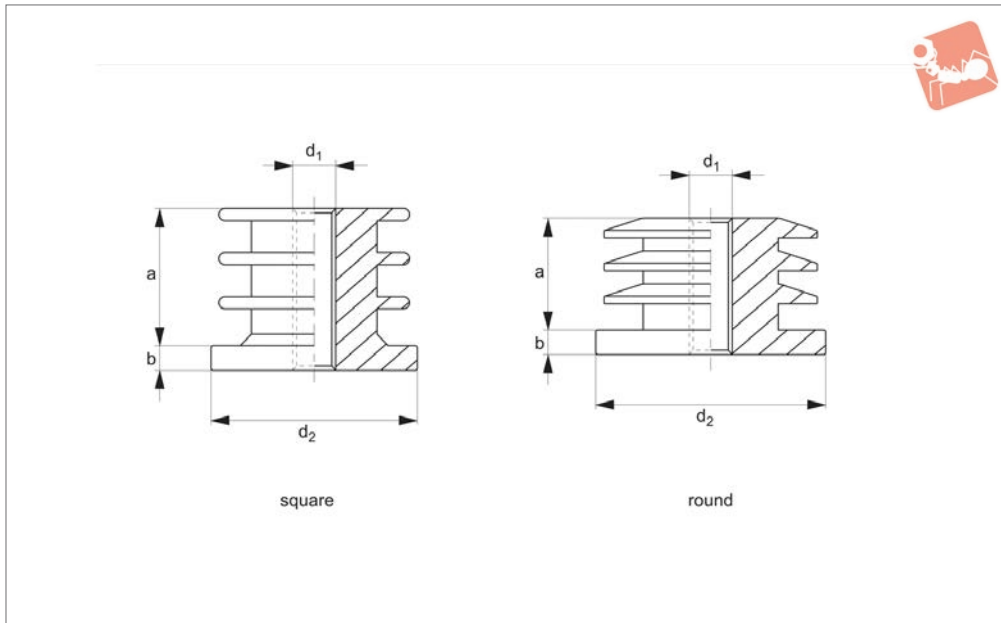

34681

THREADED FRAME INSERTS

Material
Polyamide

Technical Notes
When vibrations or dynamic loads are present these values should be reduced.

Order No.	Type	d ₁	d ₂	a	b
34681.W0015	Square	M10	15x15	18	5
34681.W0016	Square	M10	16x16	18	5
34681.W0018	Square	M10	18x18	18	5
34681.W0020	Square	M10	20x20	18	5
34681.W0022	Square	M10	22x22	18	5
34681.W0025	Square	M10	25x25	19	5
34681.W0030	Square	M10	30x30	20	6
34681.W0035	Square	M10	35x35	21	6
34681.W0040	Square	M10	40x40	22	6
34681.W0050	Square	M10	50x50	30	7
34681.W0218	Round	M10	20	18	6
34681.W0222	Round	M10	22	19	6
34681.W0225	Round	M10	25	19	6
34681.W0228	Round	M10	28	19	6
34681.W0230	Round	M10	30	19	6
34681.W0232	Round	M10	32	19	6
34681.W0235	Round	M10	35	20	6
34681.W0240	Round	M10	40	20	6
34681.W0245	Round	M10	45	21	6
34681.W0250	Round	M10	50	21	6

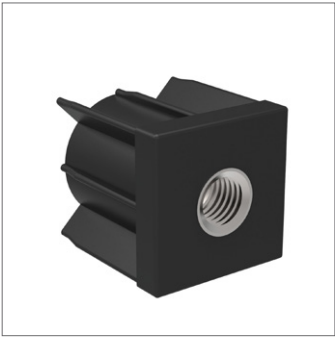

34691

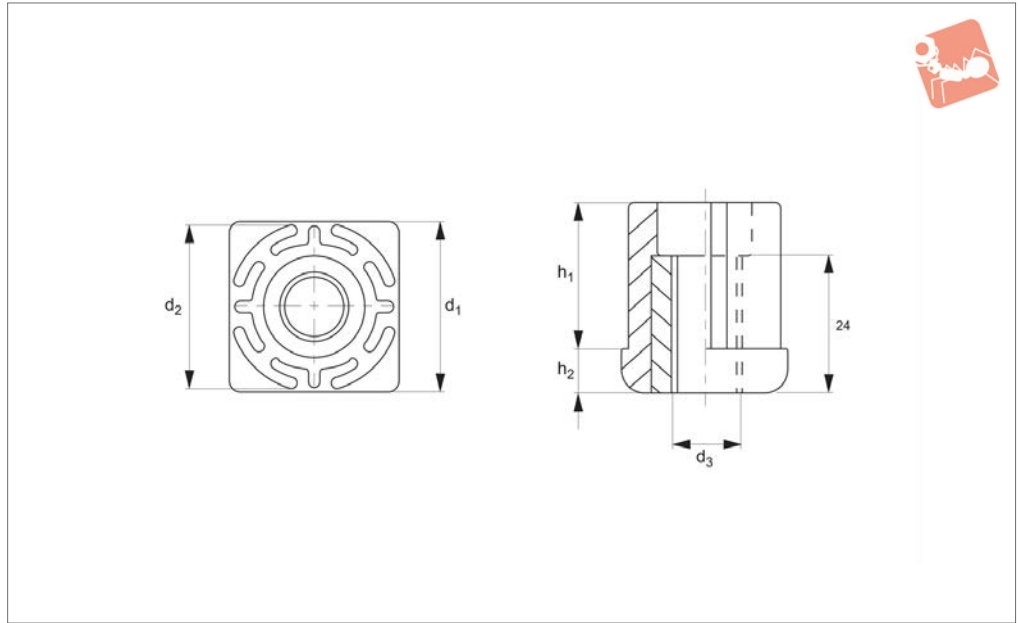

Material

Body: polyamide reinforced nylon.
Bush: brass, nickel plated.

Technical Notes

For use with levelling feet parts.

Order No.	Outerbox d ₁	Innerbox d ₂	d ₃	h ₁	h ₂	Rec. load kg max.
34691.W0108	30x30x1,5	27	M 8	35	8	500
34691.W0110	30x30x1,5	27	M10	35	8	500
34691.W0112	30x30x1,5	27	M12	35	8	500
34691.W0116	30x30x1,5	27	M16	35	8	500
34691.W0208	40x40x1,5	37	M 8	35	8	1000
34691.W0210	40x40x1,5	37	M10	35	8	1000
34691.W0212	40x40x1,5	37	M12	35	8	1000
34691.W0216	40x40x1,5	37	M16	35	8	1000
34691.W0220	40x40x1,5	37	M20	35	8	1000
34691.W0308	40x40x2,0	36	M8	35	8	1000
34691.W0310	40x40x2,0	36	M10	35	8	1000
34691.W0312	40x40x2,0	36	M12	35	8	1000
34691.W0316	40x40x2,0	36	M16	35	8	1000
34691.W0320	40x40x2,0	36	M20	35	8	1000
34691.W0416	50x50x1,5	47	M16	45	10	1000
34691.W0420	50x50x1,5	47	M20	45	10	1200
34691.W0424	50x50x1,5	47	M24	45	10	1200
34691.W0516	50x50x2,0	46	M16	45	10	1200
34691.W0520	50x50x2,0	46	M20	45	10	1200
34691.W0524	50x50x2,0	46	M24	45	10	1200



Threaded Plastic Inserts for Hollow with brass bush

Threaded Frame Inserts



THREADED FRAME INSERTS

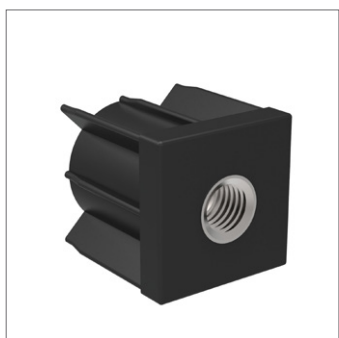

34692

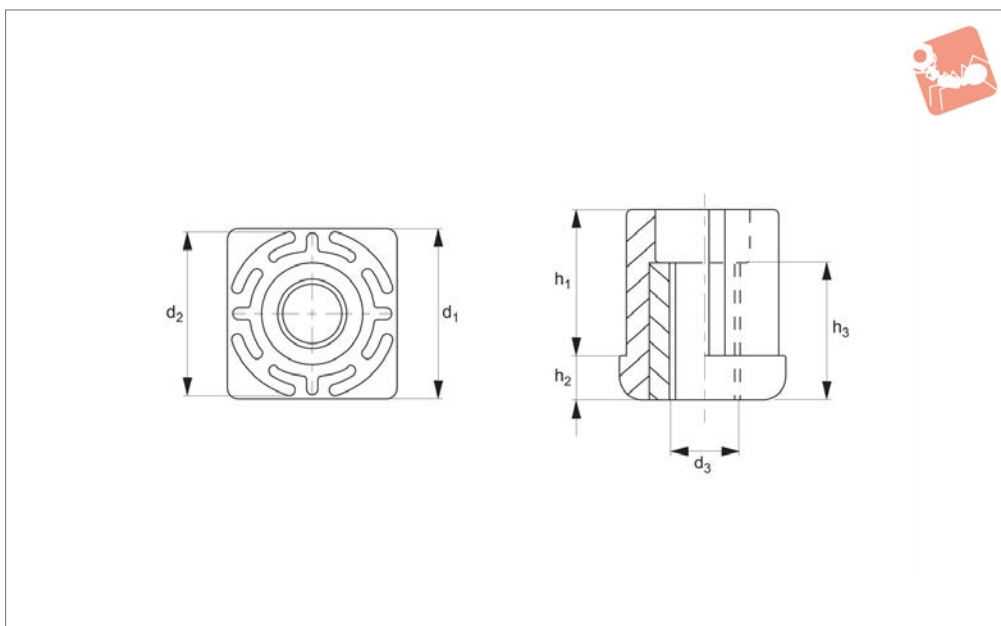

Material

Bush: stainless steel, type AISI 303.

Moulding: polyamide reinforced nylon.

Order No.	Outerbox d_1	Innerbox d_2	d_3	h_1	h_2	h_3	Load capacity for static load kg max.
34692.W0610	30x30x1,5	27	M10	35	8	24	500
34692.W0612	30x30x1,5	27	M12	35	8	24	500
34692.W0616	30x30x1,5	27	M16	35	8	24	500
34692.W0710	40x40x1,5	37	M10	35	8	24	1000
34692.W0712	40x40x1,5	37	M12	35	8	24	1000
34692.W0716	40x40x1,5	37	M16	35	8	24	1000
34692.W0720	40x40x1,5	37	M20	35	8	24	1000
34692.W0810	40x40x2,0	36	M10	35	8	24	1000
34692.W0812	40x40x2,0	36	M12	35	8	24	1000
34692.W0816	40x40x2,0	36	M16	35	8	24	1000
34692.W0820	40x40x2,0	36	M20	35	8	24	1000
34692.W0916	50x50x1,5	47	M16	45	10	24	1200
34692.W0920	50x50x1,5	47	M20	45	10	24	1200
34692.W0924	50x50x1,5	47	M24	45	10	24	1200
34692.W0952	50x50x2,0	46	M16	45	10	24	1200
34692.W0954	50x50x2,0	46	M20	45	10	24	1200
34692.W0956	50x50x2,0	46	M24	45	10	24	1200



Threaded Plastic Insert - Round with nickel plated brass bush

Threaded Frame Inserts

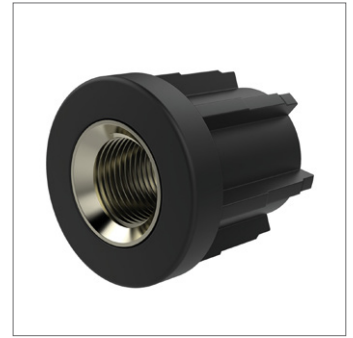

34693

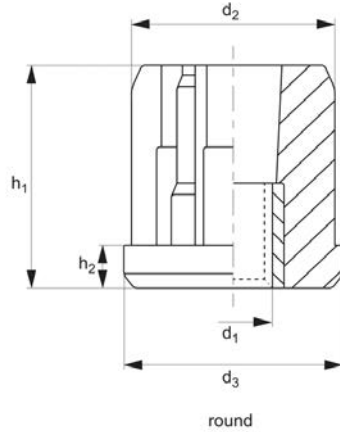

Material

Moulding: polyamide, reinforced with fiber glass.

Insert: nickel-plated brass.

Notes -

Stainless steel inserts available on request.

Order No.	d ₁	d ₂	d ₃	h ₁	h ₂	Static load kN max.
34693.W0108	M8	28.5	30	35	6	3.2
34693.W0110	M10	28.5	30	35	6	3.2
34693.W0112	M12	28.5	30	35	6	3.2
34693.W0114	M14	28.5	30	35	6	3.2
34693.W0116	M16	28.5	30	35	6	3.2
34693.W0208	M8	35.5	38	43	8	5.5
34693.W0210	M10	35.5	38	43	8	5.5
34693.W0212	M12	35.5	38	43	8	5.5
34693.W0214	M14	35.5	38	43	8	5.5
34693.W0216	M16	35.5	38	43	8	5.5
34693.W0308	M8	39.5	42	42	8	6.5
34693.W0310	M10	39.5	42	42	8	6.5
34693.W0312	M12	39.5	42	42	8	6.5
34693.W0314	M14	39.5	42	42	8	6.5
34693.W0316	M16	39.5	42	42	8	6.5
34693.W0320	M20	39.5	42	42	8	6.5
34693.W0408	M8	45.5	48	49	11	8.0
34693.W0410	M10	45.5	48	49	11	8.0
34693.W0412	M12	45.5	48	49	11	8.0
34693.W0414	M14	45.5	48	49	11	8.0
34693.W0416	M16	45.5	48	49	11	8.0
34693.W0420	M20	45.5	48	49	11	8.0
34693.W0508	M8	47.5	50	49	11	8.5
34693.W0510	M10	47.5	50	49	11	8.5
34693.W0512	M12	47.5	50	49	11	8.5
34693.W0514	M14	47.5	50	49	11	8.5
34693.W0516	M16	47.5	50	49	11	8.5
34693.W0520	M20	47.5	50	49	11	8.5
34693.W0614	M14	57.5	60	50	12	10.0
34693.W0616	M16	57.5	60	50	12	10.0
34693.W0620	M20	57.5	60	50	12	10.0
34693.W0624	M24	57.5	60	50	12	10.0
34693.W0714	M14	56.5	60	50	12	10.0
34693.W0716	M16	56.5	60	50	12	10.0



Order No.	d ₁	d ₂	d ₃	h ₁	h ₂	Static load kN max.
34693.W0720	M20	56.5	60	50	12	10.0
34693.W0724	M24	56.5	60	50	12	10.0
34693.W0814	M14	55.5	60	50	12	10.0
34693.W0816	M16	55.5	60	50	12	10.0
34693.W0820	M20	55.5	60	50	12	10.0
34693.W0824	M24	55.5	60	50	12	10.0



Threaded Plastic Insert - Square with nickel plated brass bush

Threaded Frame Inserts

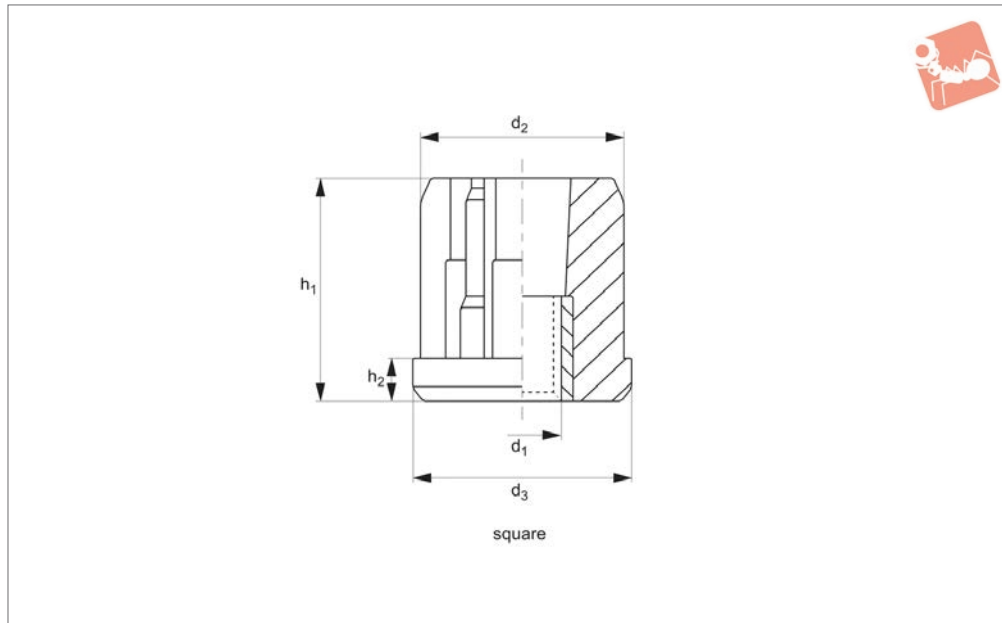

34694

THREADED FRAME INSERTS

Material

Moulding: polyamide, reinforced with fiber glass.

Insert: nickel-plated brass.

Stainless steel inserts available on request.

Notes -

Order No.	d ₁	d ₂	d ₃	h ₁	h ₂	Static load kN max.
34694.W0110	M10	27	30x30x1,5	33	6	5.5
34694.W0112	M12	27	30x30x1,5	33	6	5.5
34694.W0114	M14	27	30x30x1,5	33	6	5.5
34694.W0116	M16	27	30x30x1,5	33	6	5.5
34694.W0210	M10	32	35x35x1,5	43	8	7.0
34694.W0212	M12	32	35x35x1,5	43	8	7.0
34694.W0214	M14	32	35x35x1,5	43	8	7.0
34694.W0216	M16	32	35x35x1,5	43	8	7.0
34694.W0310	M10	37	40x40x1,5	43	8	8.0
34694.W0312	M12	37	40x40x1,5	43	8	8.0
34694.W0314	M14	37	40x40x1,5	43	8	8.0
34694.W0316	M16	37	40x40x1,5	43	8	8.0
34694.W0320	M20	37	40x40x1,5	43	8	8.0
34694.W0410	M10	36	40x40x2,0	43	8	8.0
34694.W0412	M12	36	40x40x2,0	43	8	8.0
34694.W0414	M14	36	40x40x2,0	43	8	8.0
34694.W0416	M16	36	40x40x2,0	43	8	8.0
34694.W0420	M20	36	40x40x2,0	43	8	8.0
34694.W0512	M12	47	50x50x1,5	55	10	9.5
34694.W0514	M14	47	50x50x1,5	55	10	9.5
34694.W0516	M16	47	50x50x1,5	55	10	9.5
34694.W0520	M20	47	50x50x1,5	55	10	9.5
34694.W0612	M12	45	50x50x2,0	55	10	9.5
34694.W0614	M14	45	50x50x2,0	55	10	9.5
34694.W0616	M16	45	50x50x2,0	55	10	9.5
34694.W0620	M20	45	50x50x2,0	55	10	9.5

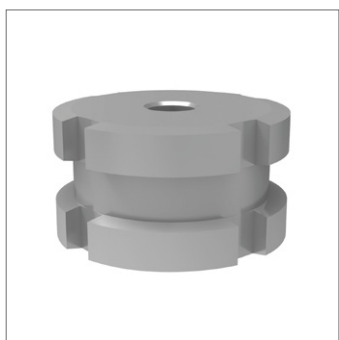

62000

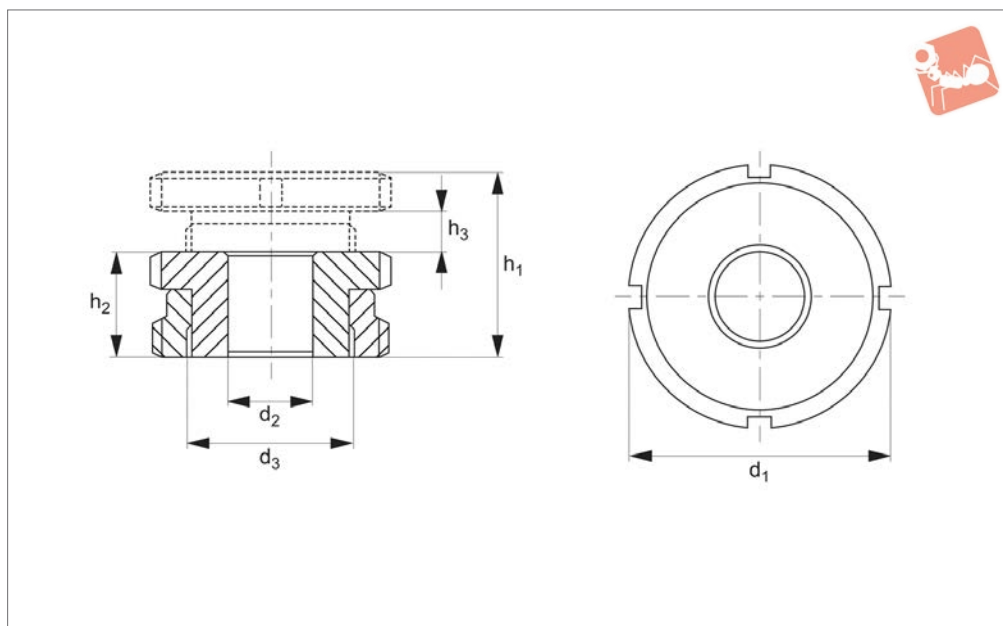

Material

Steel (type 42 CrMo4 V, 1.7225) zinc plated or stainless steel A1 (A4 on request).

Technical Notes

After setting the height, the structure can be bolted down using a suitable 8,8

strength bolt.

The net load that the unit can carry is the maximum load less the tightening torque recommended for the bolt. Designed for applications with limited space. Height adjustment is between 4 and 10mm.

Order No.	Material	For bolt	h_1	h_2	h_3	d_1	d_2	d_3	Load with bolt kN max.	Load w/o bolt kN max.
62000.W0038	Steel	M 4	19	15	4	25	4.5	M15x1,0	36.00	40.0
62000.W0039	Steel	M 5	19	15	4	25	5.5	M15x1,0	33.40	40.0
62000.W0040	Steel	M 6	19	15	4	25	6.6	M15x1,0	30.70	40.0
62000.W0050	Steel	M 6	23	18	5	32	6.6	M20x1,0	55.70	65.0
62000.W0051	Steel	M 8	23	18	5	32	9.0	M20x1,0	48.00	65.0
62000.W0052	Steel	M10	23	18	5	32	11.0	M20x1,0	37.90	65.0
62000.W0070	Steel	M10	29	22	7	45	11.0	M30x1,5	92.90	120.0
62000.W0071	Steel	M12	29	22	7	45	13.5	M30x1,5	80.40	120.0
62000.W0072	Steel	M16	29	22	7	45	17.5	M30x1,5	45.50	120.0
62000.W0090	Steel	M16	37	28	9	58	17.5	M40x1,5	136.00	210.0
62000.W0091	Steel	M20	37	28	9	58	22.0	M40x1,5	90.00	210.0
62000.W0092	Steel	M24	37	28	9	58	26.0	M40x1,5	37.00	210.0
62000.W0100	Steel	M20	43	33	10	70	22.0	M50x1,5	210.00	330.0
62000.W0101	Steel	M24	43	33	10	70	26.0	M50x1,5	157.00	330.0
62000.W0102	Steel	M30	43	33	10	70	33.0	M50x1,5	53.00	330.0
62000.W0502	Stainless steel	M 4	19	15	4	25	4.5	M15x1,0	24.14	27.1
62000.W0503	Stainless steel	M 5	19	15	4	25	5.5	M15x1,0	22.24	27.1
62000.W0504	Stainless steel	M 6	19	15	4	25	6.6	M15x1,0	20.26	27.1
62000.W0550	Stainless steel	M 6	23	18	5	32	6.6	M20x1,0	36.56	43.4
62000.W0551	Stainless steel	M 8	23	18	5	32	9.0	M20x1,0	30.86	43.4
62000.W0552	Stainless steel	M10	23	18	5	32	11.0	M20x1,0	23.41	43.4
62000.W0570	Stainless steel	M10	29	22	7	45	11.0	M30x1,5	64.01	84.0
62000.W0571	Stainless steel	M12	29	22	7	45	13.5	M30x1,5	54.82	84.0
62000.W0572	Stainless steel	M16	29	22	7	45	17.5	M30x1,5	28.90	84.0
62000.W0590	Stainless steel	M16	37	28	9	58	17.5	M40x1,5	92.90	148.0
62000.W0591	Stainless steel	M20	37	28	9	58	22.0	M40x1,5	59.08	148.0
62000.W0592	Stainless steel	M24	37	28	9	58	26.0	M40x1,5	20.30	148.0
62000.W0600	Stainless steel	M20	43	33	10	70	22.0	M50x1,5	136.08	225.0
62000.W0601	Stainless steel	M24	43	33	10	70	26.0	M50x1,5	97.30	225.0
62000.W0602	Stainless steel	M30	43	33	10	70	33.0	M50x1,5	20.60	225.0

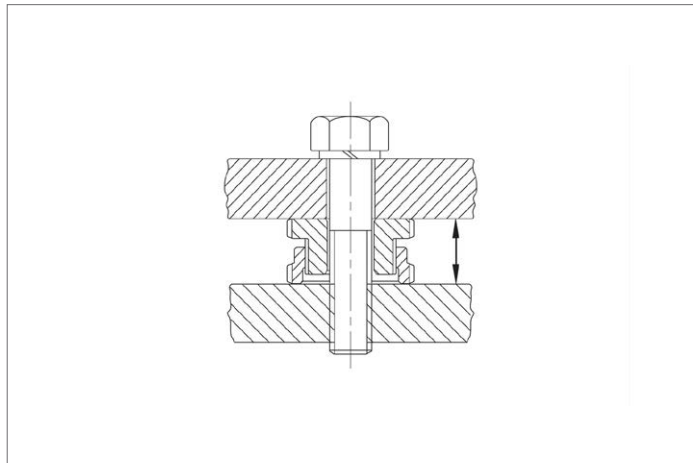

PRECISION LEVELLING ADJUSTERS



62060

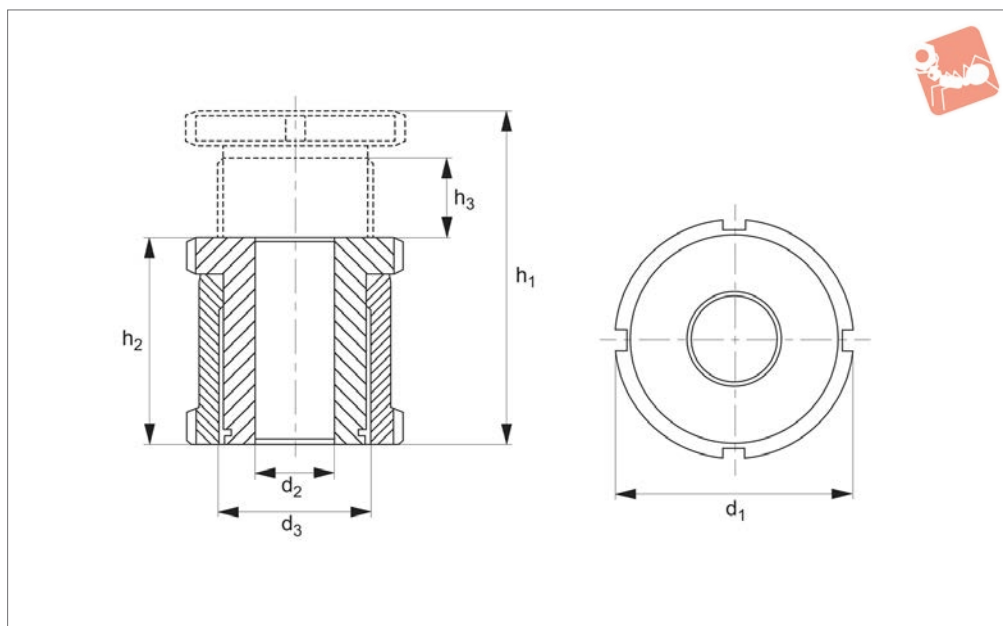

Material

Steel (type 42 CrMo4 V, 1.7225) zinc plated or stainless steel A1 (A4 on request).

Technical Notes

After setting the height, the structure can be bolted down using a suitable 8,8

strength bolt.

The net load that the unit can carry is the maximum load less the tightening torque recommended for the bolt. Designed for applications where a wide adjustment range is required - height adjustment is

equal to 15 to 40mm.

Order No.	Material	For bolt	h_1	h_2	h_3	d_1	d_2	d_3	Load with bolt kN max.	Load w/o bolt kN max.
62060.W0013	Steel	M 4	43	28	15	25	4.5	M15x1,0	36.00	40.00
62060.W0014	Steel	M 5	43	28	15	25	5.5	M15x1,0	33.40	40.00
62060.W0015	Steel	M 6	43	28	15	25	6.6	M15x1,0	30.70	40.00
62060.W0021	Steel	M 6	55	35	20	32	6.6	M20x1,0	55.70	65.00
62060.W0022	Steel	M 8	55	35	20	32	9.0	M20x1,0	48.00	65.00
62060.W0023	Steel	M10	55	35	20	32	11.0	M20x1,0	37.90	65.00
62060.W0025	Steel	M10	67	42	25	45	11.0	M30x1,5	92.90	120.00
62060.W0026	Steel	M12	67	42	25	45	13.5	M30x1,5	80.40	120.00
62060.W0027	Steel	M16	67	42	25	45	17.5	M30x1,5	45.50	120.00
62060.W0030	Steel	M16	86	54	32	58	17.5	M40x1,5	136.00	210.00
62060.W0031	Steel	M20	86	54	32	58	22.0	M40x1,5	90.00	210.00
62060.W0032	Steel	M24	86	54	32	58	26.0	M40x1,5	37.00	210.00
62060.W0040	Steel	M20	106	66	40	70	22.0	M50x1,5	210.00	330.00
62060.W0041	Steel	M24	106	66	40	70	26.0	M50x1,5	157.00	330.00
62060.W0042	Steel	M30	106	66	40	70	33.0	M50x1,5	53.00	330.00
62060.W0513	Stainless steel	M 4	43	28	15	25	4.5	M15x1,0	24.14	27.10
62060.W0514	Stainless steel	M 5	43	28	15	25	5.5	M15x1,0	22.24	27.10
62060.W0515	Stainless steel	M 6	43	28	15	25	6.6	M15x1,0	20.26	27.10
62060.W0521	Stainless steel	M 6	55	35	20	32	6.6	M20x1,0	36.56	43.40
62060.W0522	Stainless steel	M 8	55	35	20	32	9.0	M20x1,0	30.86	43.40
62060.W0523	Stainless steel	M10	55	35	20	32	11.0	M20x1,0	23.41	43.40
62060.W0525	Stainless steel	M10	67	42	25	45	11.0	M30x1,5	64.01	84.00
62060.W0526	Stainless steel	M12	67	42	25	45	13.5	M30x1,5	54.82	84.00
62060.W0527	Stainless steel	M16	67	42	25	45	17.5	M30x1,5	28.90	84.00
62060.W0530	Stainless steel	M16	86	54	32	58	17.5	M40x1,5	92.90	148.00
62060.W0531	Stainless steel	M20	86	54	32	58	22.0	M40x1,5	59.08	148.00
62060.W0532	Stainless steel	M24	86	54	32	58	26.0	M40x1,5	20.30	148.00
62060.W0540	Stainless steel	M20	106	66	40	70	22.0	M50x1,5	136.08	225.00
62060.W0541	Stainless steel	M24	106	66	40	70	26.0	M50x1,5	97.30	225.00
62060.W0542	Stainless steel	M30	106	66	40	70	33.0	M50x1,5	20.60	225.00

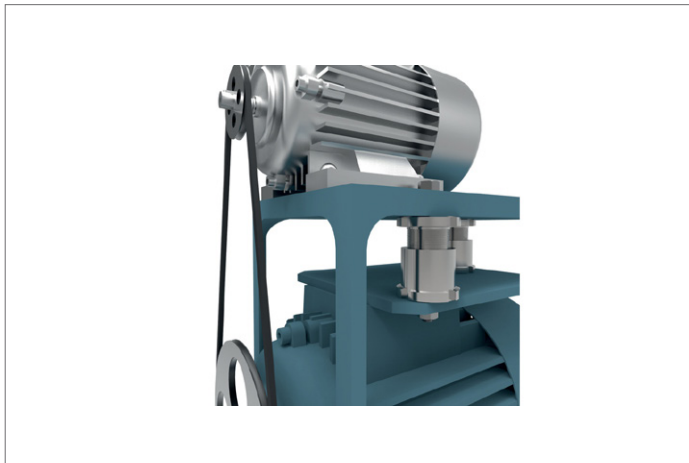



Advantages

- Precision adjusting and re-adjusting.
- Operational under heavy loads.
- Fast installation.
- Greater vertical alignment (from 4 to 105mm).
- Compensation for non-parallel bearing surfaces.
- Suitable for static and dynamic loads.
- Can be anchored to foundation.

Applications

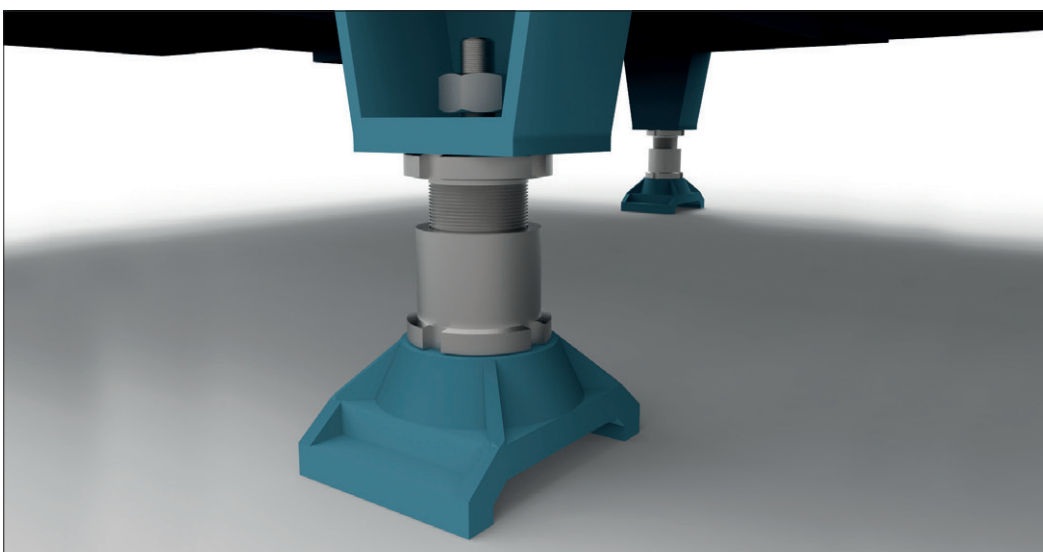

Grounded field mount - Precision Leveller no. 62060 in use on a fully metal encapsulated gas-insulated high voltage switch.

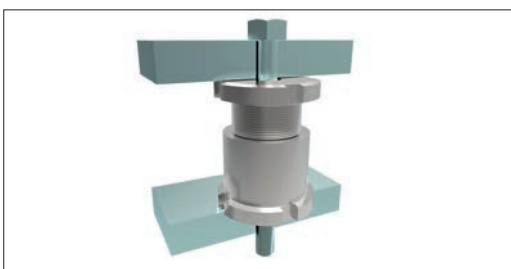

Test stand - Precision Levellers provide adjustment for the connection shaft between motor and transmission.

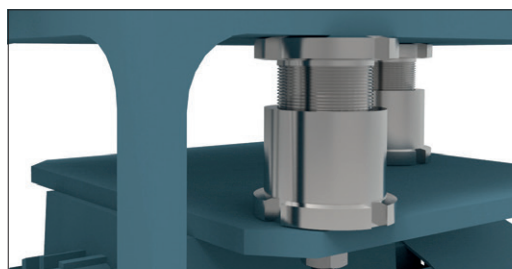

Drive train application - in this application Wixroyd Precision Levellers are used to adjust the rig to ensure correct tension of the V-belt, and to provide full support of the top mounted electric drive motor.



Plummer blocks - even multiple bearings can be levelled easily and precisely, here part no. 62000 is in use.

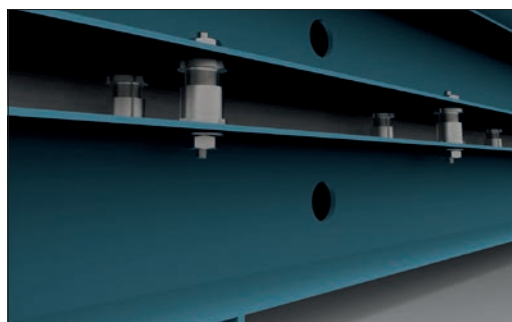

Extruder - precision adjustment of an extruder with leveller no. 62008.



Design features

Wixroyd Precision Levelling Adjusters enable accurate levelling, locating and adjusting of motors, machinery and much more, under heavy loads.

There are three key features to the design, firstly the fine threaded mounting bolt, secondly the threaded nut base and thirdly the end-stop. The fine thread of the mounting bolt and base provides precise adjustment, as well as easy re-adjustment by means of a hook spanner to DIN 1810A, see part no. 95400.

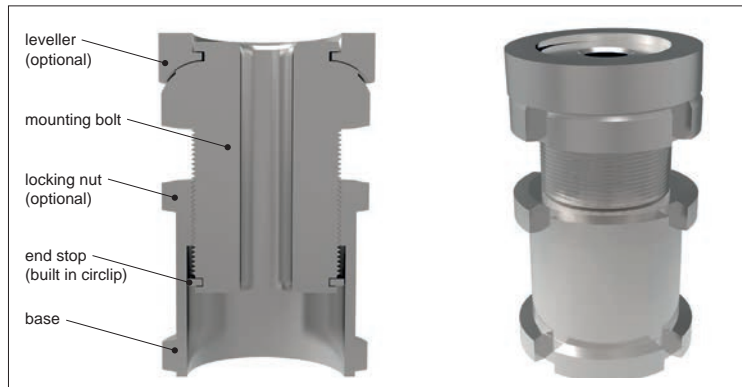

Product range



62000 - Designed for applications with limited space - height adjustment is between 4 and 14mm.



62040 - Designed for applications requiring both height adjustment (from 4 to 14mm) and precise adjustment of non-parallel surfaces, with a maximum angle of tilt 4°.



62060 - Designed for applications where a wide adjustment range is required - height adjustment equal to 15 to 55mm.



62080 - Designed for applications with a dynamic load, or where no fasteners are used. The locknut enables locking of the adjuster in the pre-set position.



62100 - For applications requiring both height adjustment (from 15 to 55mm) and precise adjustment of non-parallel surfaces, with a max. angle of tilt 4°.



62120 - The same features as part number 62100, but with the added feature of a locknut to fix adjuster in any position.



62140/62160 - Designed for applications requiring precise adjustment of non-parallel surfaces, with a maximum angle tilt 4°. The ball shim has no height adjustment feature.

Adjusters vs. levellers

Precision adjusters

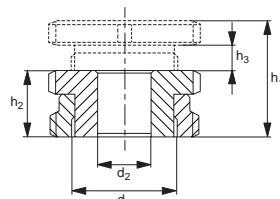

Precision levellers

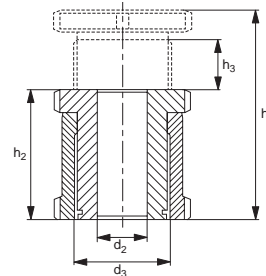

Features	62000	62002	62040	62042	62060	62080	62100	62120
Adjustment travel 4-14mm	✓	✓	✓	✓				
Adjustment travel 15-55mm					✓	✓	✓	✓
Lock nut		✓		✓		✓		✓
Slope adjustment up to 4°			✓	✓			✓	✓
Captive screw feature	✓	✓	✓	✓	✓	✓	✓	✓



62040

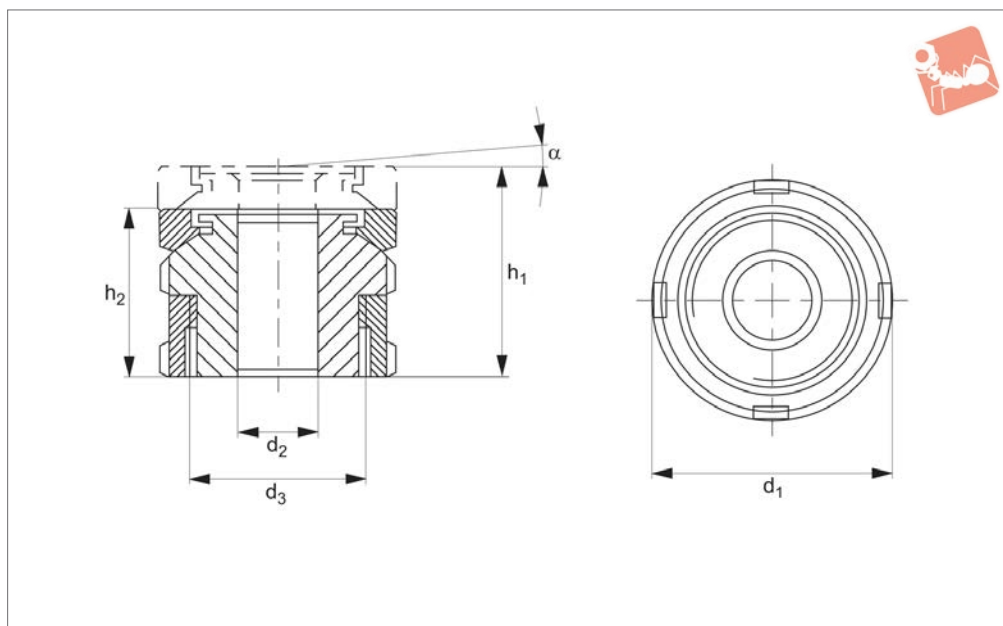

Material

Steel (type 42 CrMo4 V, 1.7225) zinc plated or stainless steel A1 (A4 on request).

Technical Notes

After setting the height, the structure can be bolted down using a suitable 8,8 strength bolt.

The net load that the unit can carry is the maximum load less the tightening torque recommended for the bolt. Please see useful info tab.

Designed for applications with limited space. Height adjustment is between 4 and 10mm. Designed for applications requiring

both height adjustment and precise adjustment of non-parallel surfaces, with a maximum angle of tilt 4°. For adjustment of non-parallel surfaces without height adjustment, see part no. 62140.

Order No.	Material	For bolt	h_1	h_2	d_1	d_2	d_3	α	Load with bolt kN max.	Load w/o bolt kN max.
62040.W0038	Steel	M 4	26	22	25	4.5	M15x1,0	4°	36.00	40.0
62040.W0039	Steel	M 5	26	22	25	5.5	M15x1,0	4°	33.40	40.0
62040.W0040	Steel	M 6	26	22	25	6.6	M15x1,0	4°	30.70	40.0
62040.W0050	Steel	M 6	31	26	32	6.6	M20x1,0	4°	55.70	65.0
62040.W0051	Steel	M 8	31	26	32	9.0	M20x1,0	4°	48.00	65.0
62040.W0052	Steel	M10	31	26	32	11.0	M20x1,0	4°	37.90	65.0
62040.W0070	Steel	M10	41	34	45	11.0	M30x1,5	4°	92.90	120.0
62040.W0071	Steel	M12	41	34	45	13.5	M30x1,5	4°	80.40	120.0
62040.W0072	Steel	M16	41	34	45	17.5	M30x1,5	4°	45.50	120.0
62040.W0090	Steel	M16	53	44	58	17.5	M40x1,5	4°	136.00	210.0
62040.W0091	Steel	M20	53	44	58	22.0	M40x1,5	4°	90.00	210.0
62040.W0092	Steel	M24	53	44	58	26.0	M40x1,5	4°	37.00	210.0
62040.W0100	Steel	M20	60	50	70	22.0	M50x1,5	4°	210.00	330.0
62040.W0101	Steel	M24	60	50	70	26.0	M50x1,5	4°	157.00	330.0
62040.W0102	Steel	M30	60	50	70	33.0	M50x1,5	4°	53.00	330.0
62040.W0538	Stainless steel	M 4	26	22	25	4.5	M15x1,0	4°	24.14	27.1
62040.W0539	Stainless steel	M 5	26	22	25	5.5	M15x1,0	4°	24.24	27.1
62040.W0540	Stainless steel	M 6	26	22	25	6.6	M15x1,0	4°	20.26	27.1
62040.W0550	Stainless steel	M 6	31	26	32	6.6	M20x1,0	4°	36.56	43.4
62040.W0551	Stainless steel	M 8	31	26	32	9.0	M20x1,0	4°	30.86	43.4
62040.W0552	Stainless steel	M10	31	26	32	11.0	M20x1,0	4°	23.41	43.4
62040.W0570	Stainless steel	M10	41	34	45	11.0	M30x1,5	4°	64.01	84.0
62040.W0571	Stainless steel	M12	41	34	45	13.5	M30x1,5	4°	54.82	84.0
62040.W0572	Stainless steel	M16	41	34	45	17.5	M30x1,5	4°	28.90	84.0
62040.W0590	Stainless steel	M16	53	44	58	17.5	M40x1,5	4°	92.90	148.0
62040.W0591	Stainless steel	M20	53	44	58	22.0	M40x1,5	4°	59.08	148.0
62040.W0592	Stainless steel	M24	53	44	58	26.0	M40x1,5	4°	20.30	148.0
62040.W0600	Stainless steel	M20	60	50	70	22.0	M50x1,5	4°	136.08	225.0
62040.W0601	Stainless steel	M24	60	50	70	26.0	M50x1,5	4°	97.30	225.0



Tilt Head Precision Adjuster

Precision Level- ling Adjusters

Order No.	Material	For bolt	h_1	h_2	d_1	d_2	d_3	α	Load with bolt kN max.	Load w/o bolt kN max.
62040.W0602	Stainless steel	M30	60	50	70	33.0	M50x1,5	4°	20.60	225.0

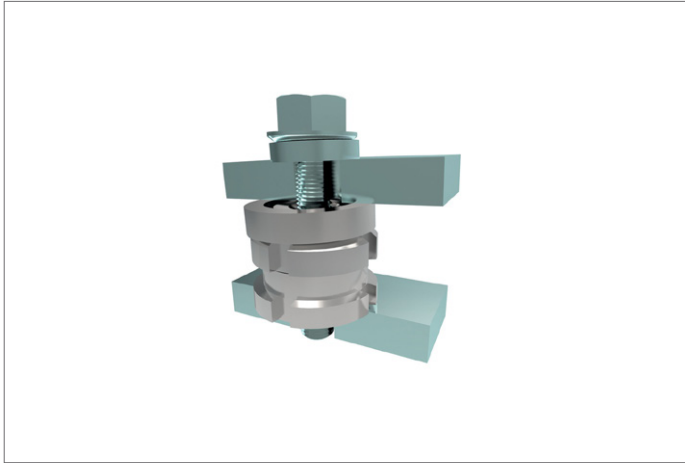



62100

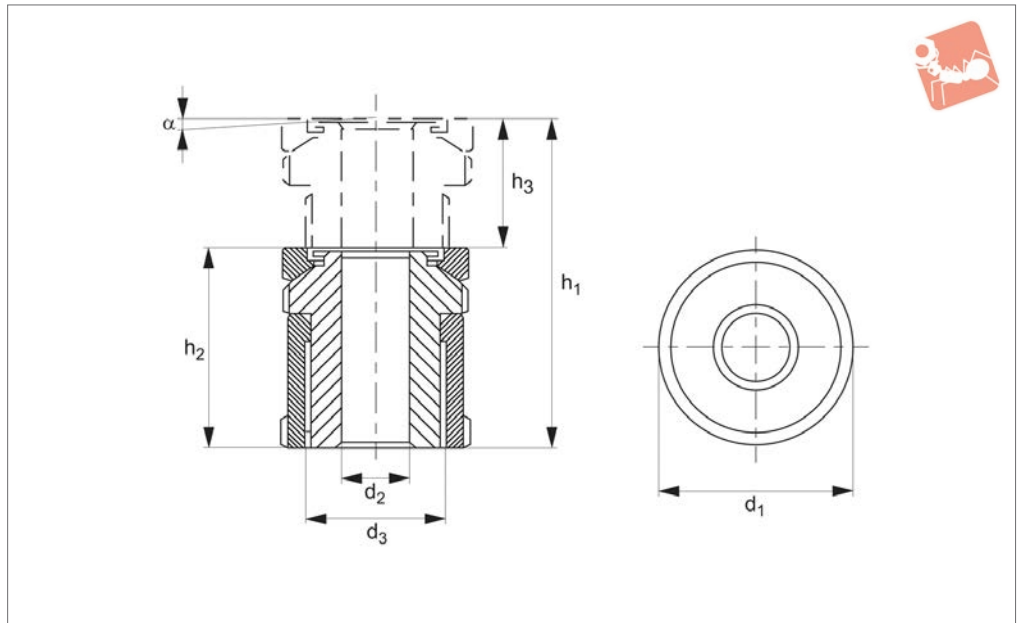

Material

Steel (type 42 CrMo4 V, 1.7225) zinc plated or stainless steel A1 (A4 on request).

Technical Notes

After setting the height, the structure can be bolted down using a suitable 8,8

strength bolt.

The net load that the unit can carry is the maximum load less the tightening torque recommended for the bolt. Designed for applications where a wide adjustment range is required - height adjustment is

equal to 15 to 40mm.

Order No.	Material	For bolt	h_1 min.	h_2 max.	d_1	d_2	d_3	α app.	Load with bolt kN max.	Load w/o bolt kN max.
62100.W0008	Steel	M 4	50	35	25	4.5	M15x1,0	4°	36.00	40.00
62100.W0009	Steel	M 5	50	35	25	5.5	M15x1,0	4°	33.40	40.00
62100.W0010	Steel	M 6	50	35	25	6.6	M15x1,0	4°	30.70	40.00
62100.W0014	Steel	M 6	63	43	32	6.6	M20x1,0	4°	56.70	65.00
62100.W0015	Steel	M 8	63	43	32	9.0	M20x1,0	4°	48.90	65.00
62100.W0016	Steel	M10	63	43	32	11.0	M20x1,0	4°	37.90	65.00
62100.W0017	Steel	M10	79	54	45	11.0	M30x1,5	4°	92.90	120.00
62100.W0018	Steel	M12	79	54	45	13.5	M30x1,5	4°	80.40	120.00
62100.W0019	Steel	M16	79	54	45	17.5	M30x1,5	4°	45.50	120.00
62100.W0020	Steel	M16	102	70	58	17.5	M40x1,5	4°	136.00	210.00
62100.W0021	Steel	M20	102	70	58	22.0	M40x1,5	4°	90.80	210.00
62100.W0023	Steel	M24	102	70	58	26.0	M40x1,5	4°	37.00	210.00
62100.W0030	Steel	M20	123	83	70	22.0	M50x1,5	4°	210.00	330.00
62100.W0031	Steel	M24	123	83	70	26.0	M50x1,5	4°	157.00	330.00
62100.W0032	Steel	M30	123	83	70	33.0	M50x1,5	4°	53.00	330.00
62100.W0508	Stainless Steel	M 4	50	35	25	4.5	M15x1,0	4°	24.14	27.10
62100.W0509	Stainless Steel	M 5	50	35	25	5.5	M15x1,0	4°	22.24	27.10
62100.W0510	Stainless Steel	M 6	50	35	25	6.6	M15x1,0	4°	20.26	27.10
62100.W0514	Stainless Steel	M 6	63	43	32	6.6	M20x1,0	4°	36.56	43.40
62100.W0515	Stainless Steel	M 8	63	43	32	9.0	M20x1,0	4°	30.86	43.40
62100.W0516	Stainless Steel	M10	63	43	32	11.0	M20x1,0	4°	23.41	43.40
62100.W0517	Stainless Steel	M10	79	54	45	11.0	M30x1,5	4°	64.01	84.00
62100.W0518	Stainless Steel	M12	79	54	45	13.5	M30x1,5	4°	54.52	84.00
62100.W0519	Stainless Steel	M16	79	54	45	17.5	M30x1,5	4°	28.90	84.00
62100.W0520	Stainless Steel	M16	102	70	58	17.5	M40x1,5	4°	92.90	148.00
62100.W0521	Stainless Steel	M20	102	70	58	22.0	M40x1,5	4°	59.08	148.00
62100.W0523	Stainless Steel	M24	102	70	58	26.0	M40x1,5	4°	20.30	148.00
62100.W0530	Stainless Steel	M20	123	83	70	22.0	M50x1,5	4°	136.08	225.00
62100.W0531	Stainless Steel	M24	123	83	70	26.0	M50x1,5	4°	97.30	225.00
62100.W0532	Stainless Steel	M30	123	83	70	33.0	M50x1,5	4°	20.60	225.00



Precision Adjuster with locking nut

Precision Level- ling Adjusters

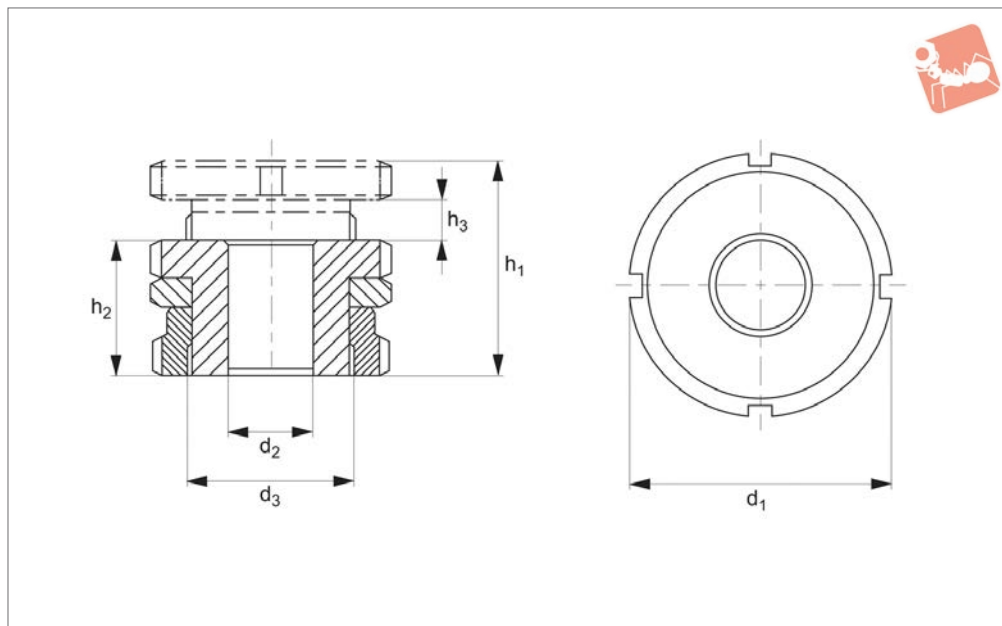

62002

PRECISION LEVELLING ADJUSTERS

Material

Steel (type 42 CrMo4 V, 1.7225) zinc plated or stainless steel A1 (A4 on request).

Technical Notes

After setting the height, the structure can be bolted down using a suitable 8,8

strength bolt.

The net load that the unit can carry is the maximum load less the tightening torque recommended for the bolt. Designed for applications with limited space. Height adjustment is between 4 and 10mm. The

lock nut included enables the adjuster to be secured in a present position and is recommended for use on applications with a dynamic load or where fasteners are not used.

Order No.	Material	For bolt	h_1	h_2	h_3	d_1	d_2	d_3	Load with bolt kN max.	Load w/o bolt kN max.
62002.W0038	Steel	M 4	24	20	4	25	4.5	M15x1,0	36.00	40.00
62002.W0039	Steel	M 5	24	20	4	25	5.5	M15x1,0	33.40	40.00
62002.W0040	Steel	M 6	24	20	4	25	6.6	M15x1,0	30.70	40.00
62002.W0050	Steel	M 6	29	24	5	32	6.6	M20x1,0	55.70	65.00
62002.W0051	Steel	M 8	29	24	5	32	9.0	M20x1,0	48.00	65.00
62002.W0052	Steel	M10	29	24	5	32	11.0	M20x1,0	37.90	65.00
62002.W0070	Steel	M10	36	29	7	45	11.0	M30x1,5	92.90	120.00
62002.W0071	Steel	M12	36	29	7	45	13.5	M30x1,5	80.40	120.00
62002.W0072	Steel	M16	36	29	7	45	17.5	M30x1,5	45.50	120.00
62002.W0090	Steel	M16	46	37	9	58	17.5	M40x1,5	136.00	210.00
62002.W0091	Steel	M20	46	37	9	58	22.0	M40x1,5	90.00	210.00
62002.W0092	Steel	M24	46	37	9	58	26.0	M40x1,5	37.00	210.00
62002.W0100	Steel	M20	54	44	10	70	22.0	M50x1,5	210.00	330.00
62002.W0101	Steel	M24	54	44	10	70	26.0	M50x1,5	157.00	330.00
62002.W0102	Steel	M30	54	44	10	70	33.0	M50x1,5	53.00	330.00
62002.W0538	Stainless Steel	M 4	24	20	4	25	4.5	M15x1,0	24.14	27.10
62002.W0539	Stainless Steel	M 5	24	20	4	25	5.5	M15x1,0	24.14	27.10
62002.W0540	Stainless Steel	M 6	24	20	4	25	6.6	M15x1,0	20.26	27.10
62002.W0550	Stainless Steel	M 6	29	24	5	32	6.6	M20x1,0	36.56	43.40
62002.W0551	Stainless Steel	M 8	29	24	5	32	9.0	M20x1,0	30.86	43.40
62002.W0552	Stainless Steel	M10	29	24	5	32	11.0	M20x1,0	23.41	43.40
62002.W0570	Stainless Steel	M10	36	29	7	45	11.0	M30x1,5	64.01	84.00
62002.W0571	Stainless Steel	M12	36	29	7	45	13.5	M30x1,5	54.82	84.00
62002.W0572	Stainless Steel	M16	36	29	7	45	17.5	M30x1,5	28.90	84.00
62002.W0590	Stainless Steel	M16	46	37	9	58	17.5	M40x1,5	92.90	148.00
62002.W0591	Stainless Steel	M20	46	37	9	58	22.0	M40x1,5	59.08	148.00
62002.W0592	Stainless Steel	M24	46	37	9	58	26.0	M40x1,5	20.30	148.00
62002.W0600	Stainless Steel	M20	54	44	10	70	22.0	M50x1,5	136.08	225.00
62002.W0601	Stainless Steel	M24	54	44	10	70	26.0	M50x1,5	59.08	225.00
62002.W0602	Stainless Steel	M30	54	44	10	70	33.0	M50x1,5	20.60	225.00



62080

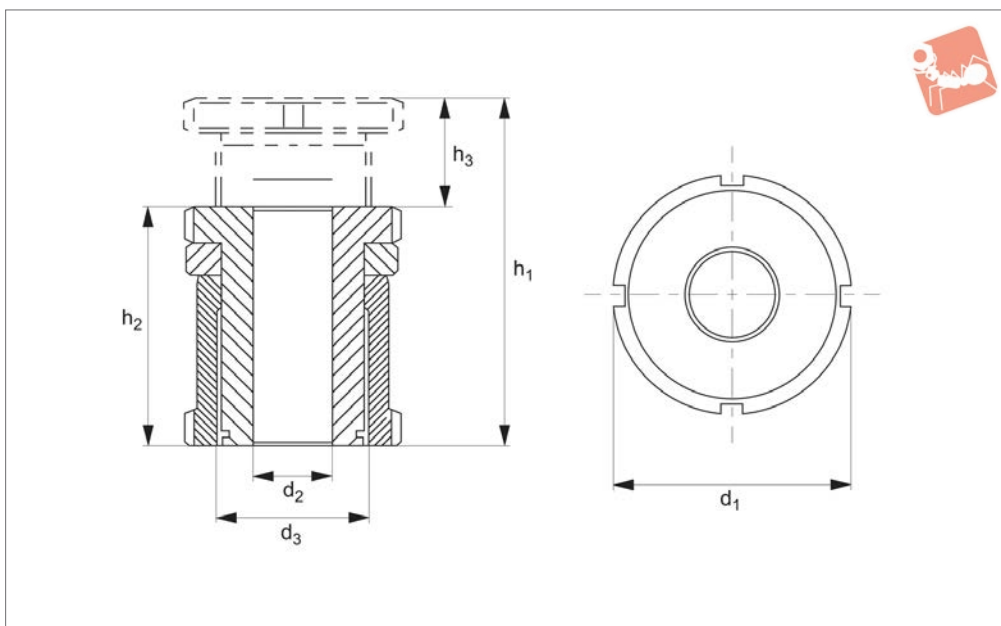

Material

Steel (type 42 CrMo4 V, 1.7225) zinc plated or stainless steel A1 (A4 on request).

Technical Notes

After setting the height, the structure can be bolted down using a suitable 8,8

strength bolt.

The net load that the unit can carry is the maximum load less the tightening torque recommended for the bolt.

Designed for applications with a dynamic load, or where no fasteners are used. The

locknut enables locking of the adjuster in a pre-set position.

Order No.	Material	For bolt	h_1	h_2	h_3	d_1	d_2	d_3	Load with bolt kN max.	Load w/o bolt kN max.
62080.W0008	Steel	M 4	43	33	10	25	4.5	M15x1,0	36.00	40.00
62080.W0009	Steel	M 5	43	33	10	25	5.5	M15x1,0	33.40	40.00
62080.W0010	Steel	M 6	43	33	10	25	6.6	M15x1,0	30.70	40.00
62080.W0014	Steel	M 6	55	41	14	32	6.6	M20x1,0	55.70	65.00
62080.W0015	Steel	M 8	55	41	14	32	9.0	M20x1,0	48.00	65.00
62080.W0016	Steel	M10	55	41	14	32	11.0	M20x1,0	37.90	65.00
62080.W0017	Steel	M10	67	49	18	45	11.0	M30x1,5	92.90	120.00
62080.W0018	Steel	M12	67	49	18	45	13.5	M30x1,5	80.40	120.00
62080.W0019	Steel	M16	67	49	18	45	17.5	M30x1,5	45.50	120.00
62080.W0020	Steel	M16	86	63	23	58	17.5	M40x1,5	136.00	210.00
62080.W0021	Steel	M20	86	63	23	58	22.0	M40x1,5	90.00	210.00
62080.W0023	Steel	M24	86	63	23	58	26.0	M40x1,5	37.00	210.00
62080.W0030	Steel	M20	106	77	29	70	22.0	M50x1,5	210.00	330.00
62080.W0031	Steel	M24	106	77	29	70	26.0	M50x1,5	157.00	330.00
62080.W0032	Steel	M30	106	77	29	70	33.0	M50x1,5	53.00	330.00
62080.W0508	Stainless steel	M 4	43	33	10	25	4.5	M15x1,0	24.14	27.10
62080.W0509	Stainless steel	M 5	43	33	10	25	5.5	M15x1,0	22.24	27.10
62080.W0510	Stainless steel	M 6	43	33	10	25	6.6	M15x1,0	20.26	27.10
62080.W0514	Stainless steel	M 6	55	41	14	32	6.6	M20x1,0	36.56	43.40
62080.W0515	Stainless steel	M 8	55	41	14	32	9.0	M20x1,0	30.86	43.40
62080.W0516	Stainless steel	M10	55	41	14	32	11.0	M20x1,0	23.41	43.40
62080.W0517	Stainless steel	M10	67	49	18	45	11.0	M30x1,5	64.01	84.00
62080.W0518	Stainless steel	M12	67	49	18	45	13.5	M30x1,5	54.82	84.00
62080.W0519	Stainless steel	M16	67	49	18	45	17.5	M30x1,5	28.90	84.00
62080.W0520	Stainless steel	M16	86	63	23	58	17.5	M40x1,5	92.90	148.00
62080.W0521	Stainless steel	M20	86	63	23	58	22.0	M40x1,5	59.08	148.00
62080.W0523	Stainless steel	M24	86	63	23	58	26.0	M40x1,5	20.30	148.00
62080.W0530	Stainless steel	M20	106	77	29	70	22.0	M50x1,5	136.08	225.00
62080.W0531	Stainless steel	M24	106	77	29	70	26.0	M50x1,5	97.30	225.00
62080.W0532	Stainless steel	M30	106	77	29	70	33.0	M50x1,5	20.60	225.00



Precision Adjuster with locking nut

Precision Level- ling Adjusters



PRECISION LEVELLING ADJUSTERS



62042

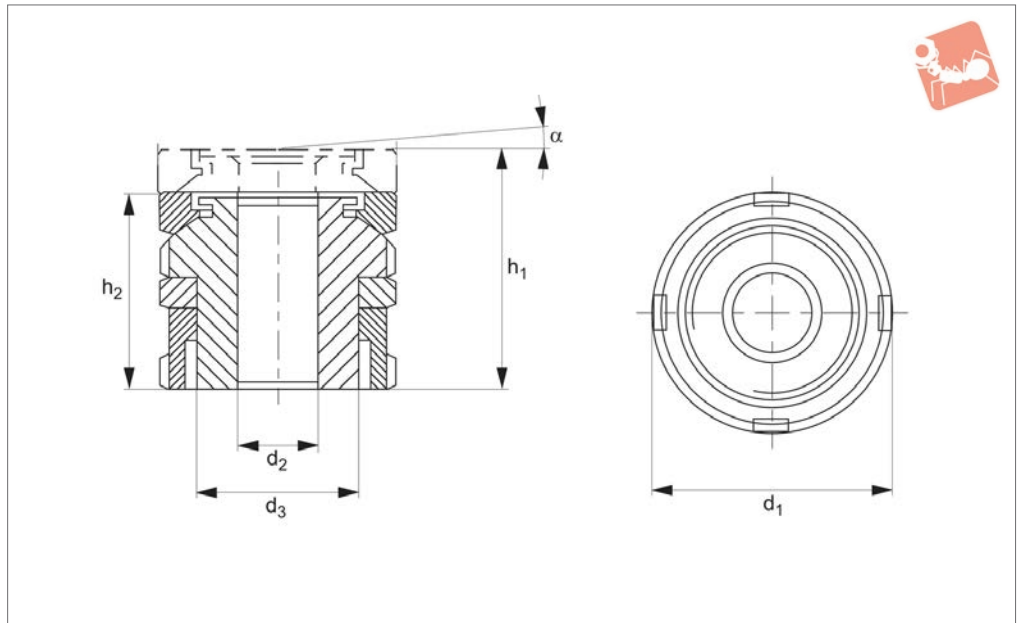

Material

Steel (type 42 CrMo4 V, 1.7225) zinc plated or stainless steel A1 (A4 on request).

Technical Notes

The application of the ball head precision adjuster with lock nut facilitates precise

adjustment of non-parallel surfaces with a maximum adjustment angle of symbol α / symbol 4° . The lock nut included enables the adjuster to be secured in a present position. The static net load is calculable after subtracting the pre-load (bolt

strength class 8.8) from the total load. The lock nut included enables the adjuster to be secured in a preset position.

Order No.	Material	For bolt	h_1 min.	h_2 max.	d_1	d_2	d_3	α app.	Load with bolt kN max.	Load w/o bolt kN max.
62042.W0038	Steel	M 4	31	27	25	4.5	M15x1,0	4°	36.00	40.00
62042.W0039	Steel	M 5	31	27	25	5.5	M15x1,0	4°	33.40	40.00
62042.W0040	Steel	M 6	31	27	25	6.6	M15x1,0	4°	30.70	40.00
62042.W0050	Steel	M 6	37	32	32	6.6	M20x1,0	4°	55.70	65.00
62042.W0051	Steel	M 8	37	32	32	9.0	M20x1,0	4°	48.00	65.00
62042.W0052	Steel	M10	37	32	32	11.0	M20x1,0	4°	37.90	65.00
62042.W0070	Steel	M10	48	41	45	11.0	M30x1,5	4°	92.90	120.00
62042.W0071	Steel	M12	48	41	45	13.5	M30x1,5	4°	80.40	120.00
62042.W0072	Steel	M16	48	41	45	17.5	M30x1,5	4°	45.50	120.00
62042.W0090	Steel	M16	62	53	58	17.5	M40x1,5	4°	136.00	210.00
62042.W0091	Steel	M20	62	53	58	22.0	M40x1,5	4°	90.00	210.00
62042.W0092	Steel	M24	62	53	58	26.0	M40x1,5	4°	37.00	210.00
62042.W0100	Steel	M20	71	61	70	26.0	M50x1,5	4°	136.00	330.00
62042.W0101	Steel	M24	71	61	70	33.0	M50x1,5	4°	157.00	330.00
62042.W0102	Steel	M30	71	61	70	39.0	M50x1,5	4°	53.00	330.00
62042.W0538	Stainless Steel	M 4	31	27	25	4.5	M15x1,0	4°	36.00	27.10
62042.W0539	Stainless Steel	M 5	31	27	25	5.5	M15x1,0	4°	33.40	27.10
62042.W0540	Stainless Steel	M 6	31	27	25	6.6	M15x1,0	4°	30.70	27.10
62042.W0550	Stainless Steel	M 6	37	32	32	6.6	M20x1,0	4°	36.56	43.40
62042.W0551	Stainless Steel	M 8	37	32	32	9.0	M20x1,0	4°	30.86	43.40
62042.W0552	Stainless Steel	M10	37	32	32	11.0	M20x1,0	4°	23.41	43.40
62042.W0570	Stainless Steel	M10	48	41	45	11.0	M30x1,5	4°	64.01	84.00
62042.W0571	Stainless Steel	M12	48	41	45	13.5	M30x1,5	4°	54.82	84.00
62042.W0572	Stainless Steel	M16	48	41	45	17.5	M30x1,5	4°	28.90	84.00
62042.W0590	Stainless Steel	M16	62	53	58	17.5	M40x1,5	4°	92.90	148.00
62042.W0591	Stainless Steel	M20	62	53	58	22.0	M40x1,5	4°	59.08	148.00
62042.W0592	Stainless Steel	M24	62	53	58	26.0	M40x1,5	4°	20.30	148.00
62042.W0600	Stainless Steel	M20	71	61	70	26.0	M50x1,5	4°	136.08	225.00
62042.W0601	Stainless Steel	M24	71	61	70	33.0	M50x1,5	4°	97.30	225.00
62042.W0602	Stainless Steel	M30	71	61	70	39.0	M50x1,5	4°	20.60	225.00



Tilt Head Precision Adjuster

tall with locking nut

Precision Leveling Adjusters

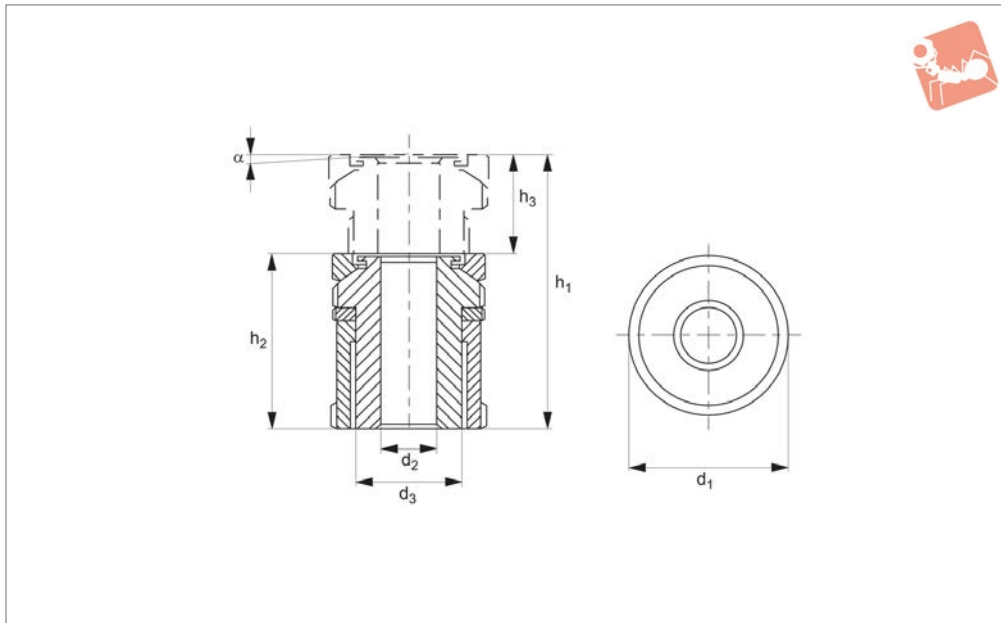

62120

PRECISION LEVELLING ADJUSTERS

Material

Steel (type 42 CrMo4 V, 1.7225) zinc plated or stainless steel A1 (A4 on request).

Technical Notes

After setting the height, the structure can be bolted down using a suitable 8,8

strength bolt.

The net load that the unit can carry is the maximum load less the tightening torque recommended for the bolt.

Designed for applications where a wide adjustment range is required - height

adjustment is equal to 15 to 40mm.

Order No.	Material	For bolt	h_1	h_2	h_3	d_1	d_2	d_3	α app.	Load with bolt kN max.	Load w/o bolt kN max.
62120.W0008	Steel	M 4	50	40	10	25	4.5	M15x1,0	4°	36.00	40.00
62120.W0009	Steel	M 5	50	40	10	25	5.5	M15x1,0	4°	33.40	40.00
62120.W0010	Steel	M 6	50	40	10	25	6.5	M15x1,0	4°	30.70	40.00
62120.W0014	Steel	M 6	63	49	14	32	6.6	M20x1,0	4°	55.70	65.00
62120.W0015	Steel	M 8	63	49	14	32	9.0	M20x1,0	4°	48.00	65.00
62120.W0016	Steel	M10	63	49	14	32	11.0	M20x1,0	4°	37.90	65.00
62120.W0017	Steel	M10	79	61	18	45	11.0	M30x1,5	4°	92.90	120.00
62120.W0018	Steel	M12	79	61	18	45	13.5	M30x1,5	4°	80.40	120.00
62120.W0019	Steel	M16	79	61	18	45	17.5	M30x1,5	4°	45.50	120.00
62120.W0020	Steel	M16	102	79	23	58	17.5	M40x1,5	4°	136.00	210.00
62120.W0021	Steel	M20	102	79	23	58	22.0	M40x1,5	4°	90.00	210.00
62120.W0023	Steel	M24	102	79	23	58	26.0	M40x1,5	4°	37.00	210.00
62120.W0030	Steel	M20	123	94	29	70	22.0	M50x1,5	4°	210.00	330.00
62120.W0031	Steel	M24	123	94	29	70	26.0	M50x1,5	4°	157.00	330.00
62120.W0032	Steel	M30	123	94	29	70	33.0	M50x1,5	4°	53.00	330.00
62120.W0508	Stainless steel	M 4	50	40	10	25	4.5	M15x1,0	4°	24.14	27.10
62120.W0509	Stainless steel	M 5	50	40	10	25	5.5	M15x1,0	4°	22.24	27.10
62120.W0510	Stainless steel	M 6	50	40	10	25	6.5	M15x1,0	4°	20.26	27.10
62120.W0514	Stainless steel	M 6	63	49	14	32	6.6	M20x1,0	4°	36.56	43.40
62120.W0515	Stainless steel	M 8	63	49	14	32	9.0	M20x1,0	4°	30.86	43.40
62120.W0516	Stainless steel	M10	63	49	14	32	11.0	M20x1,0	4°	23.41	43.40
62120.W0517	Stainless steel	M10	79	61	18	45	11.0	M30x1,5	4°	64.01	84.00
62120.W0518	Stainless steel	M12	79	61	18	45	13.5	M30x1,5	4°	54.82	84.00
62120.W0519	Stainless steel	M16	79	61	18	45	17.5	M30x1,5	4°	28.90	84.00
62120.W0520	Stainless steel	M16	102	79	23	58	17.5	M40x1,5	4°	92.90	148.00
62120.W0521	Stainless steel	M20	102	79	23	58	22.0	M40x1,5	4°	59.08	148.00
62120.W0523	Stainless steel	M24	102	79	23	58	26.0	M40x1,5	4°	20.30	148.00
62120.W0530	Stainless steel	M20	123	94	29	70	22.0	M50x1,5	4°	136.08	225.00
62120.W0531	Stainless steel	M24	123	94	29	70	26.0	M50x1,5	4°	97.30	225.00
62120.W0532	Stainless steel	M30	123	94	29	70	33.0	M50x1,5	4°	20.60	225.00

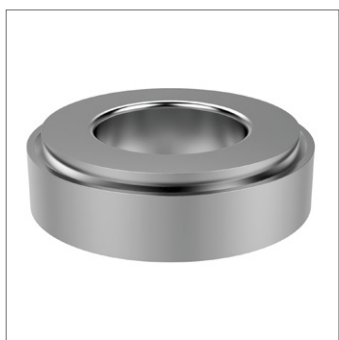

62140

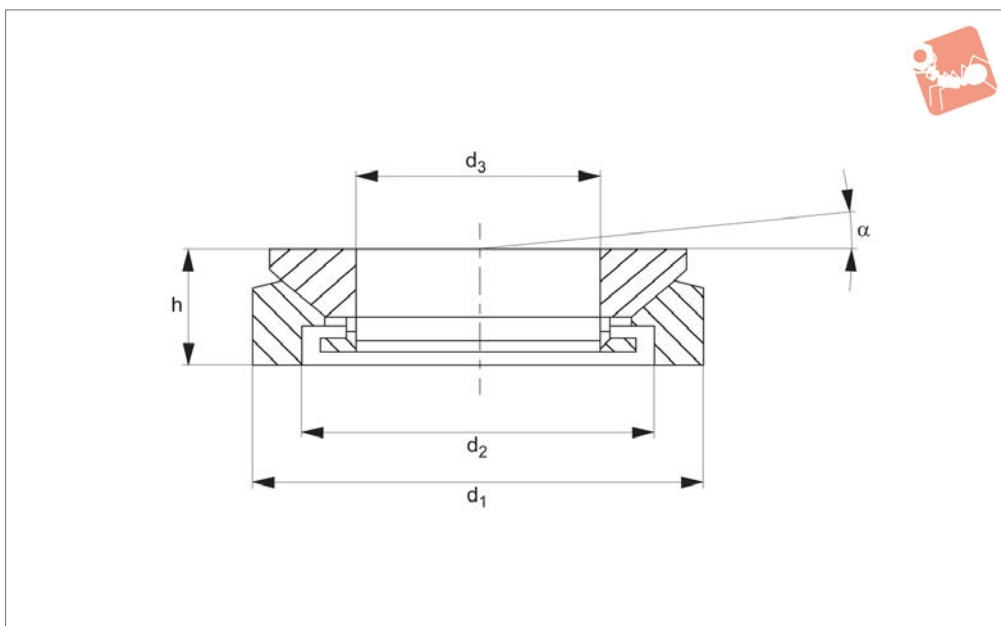

Material

Steel (type 42 CrMo4 V, 1.7225) zinc plated or stainless steel A1 (A4 on request).

Technical Notes

Compensates for non-level surfaces with a maximum angle of tilt 4°. Please remember

that the fixing screw and washer may also require support if the bearing surface is out of parallel by more than 1°.

The ball shim has no height adjustment feature.

Order No.	Material	For bolt	d ₁	d ₂	d ₃	h	α app.
62140.W0015	Steel	M 6	25	15	8.5	8.0	4°
62140.W0020	Steel	M10	32	20	13.0	10.0	4°
62140.W0030	Steel	M16	45	30	20.0	12.5	4°
62140.W0040	Steel	M24	58	38	29.0	16.0	4°
62140.W0050	Steel	M30	70	48	36.0	20.0	4°
62140.W0060	Steel	M36	80	61	44.0	20.0	4°
62140.W0080	Steel	M48	105	78	58.0	25.0	4°
62140.W0515	Stainless steel	M 6	25	15	8.5	8.0	4°
62140.W0520	Stainless steel	M10	32	20	13.0	10.0	4°
62140.W0530	Stainless steel	M16	45	30	20.0	12.5	4°
62140.W0540	Stainless steel	M24	58	38	29.0	16.0	4°
62140.W0550	Stainless steel	M30	70	48	36.0	20.0	4°
62140.W0560	Stainless steel	M36	80	61	44.0	20.0	4°
62140.W0580	Stainless steel	M48	105	78	58.0	25.0	4°



Spacers

for part nos. 62000 to 62140

Precision Level- ling Adjusters

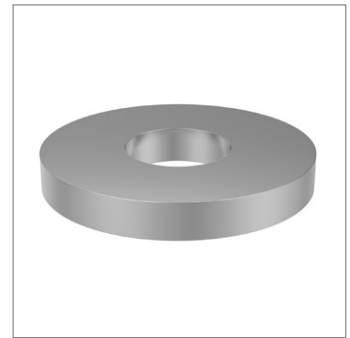
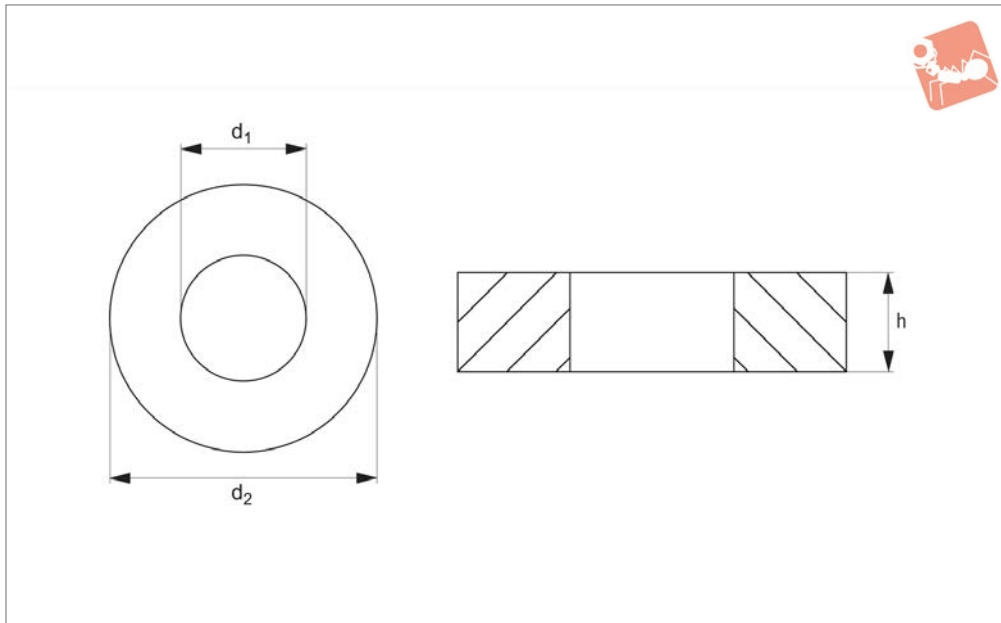

62160

PRECISION LEVELLING ADJUSTERS

Material

Steel (type 42 CrMo4 V, 1.7225) zinc plated or stainless steel A1 (A4 on request).

Technical Notes

Used to bridge gaps on applications where the height adjustment of an adjuster is

insufficient.

Order No.	Material	For bolt	d ₁	d ₂	h
62160.W0015	Steel	M 6	6.6	25	4
62160.W0020	Steel	M10	11.0	32	5
62160.W0030	Steel	M16	17.5	45	6
62160.W0040	Steel	M24	26.0	58	8
62160.W0050	Steel	M30	33.0	70	10
62160.W0060	Steel	M36	39.0	80	12
62160.W0080	Steel	M48	52.0	105	16
62160.W0515	Stainless steel	M 6	6.6	25	4
62160.W0520	Stainless steel	M10	11.0	32	5
62160.W0530	Stainless steel	M16	17.5	45	6
62160.W0540	Stainless steel	M24	26.0	58	8
62160.W0550	Stainless steel	M30	33.0	70	10
62160.W0560	Stainless steel	M36	39.0	80	12
62160.W0580	Stainless steel	M48	52.0	105	16

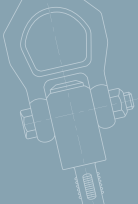

65704

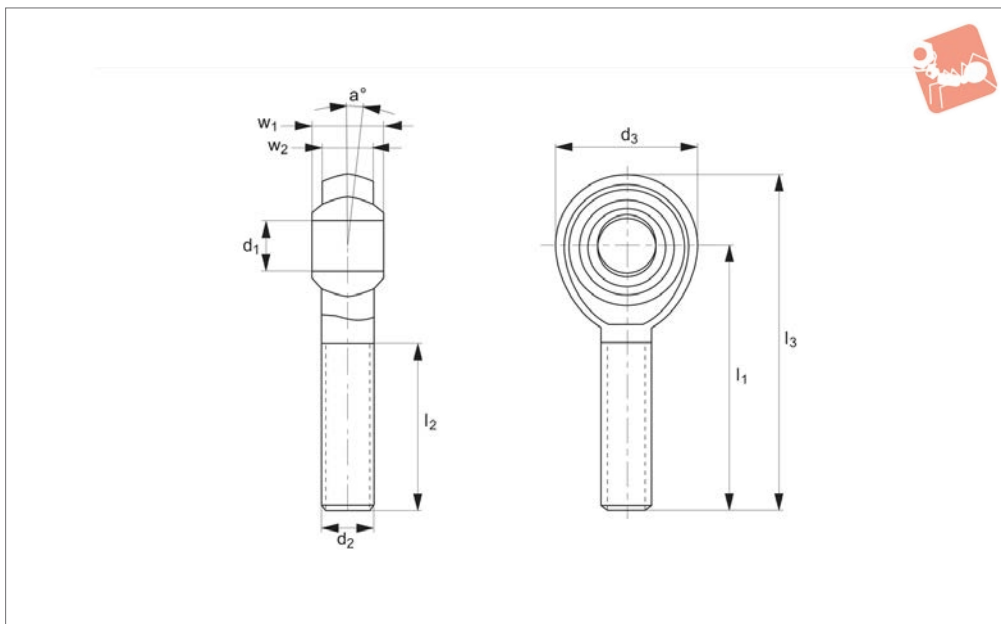

Material

Ball: low carbon steel, surface hardened.
Silver zinc plated.
Housing: low carbon steel, zinc plated for

corrosion resistance.

Bearing race: teflon.
Brass bearing with PTFE composite lining.

Technical Notes

Standard thread is right hand thread.

Order No.	Thread hand	d ₁ tol. H7	l ₁	d ₂	d ₃	l ₂	a	l ₃	w ₁	w ₂	Static load C ₀ kN max.
65704.W0005	Right	5	33	M5	18	19	13	42	8	6.00	4.8
65704.W0006	Right	6	36	M6	20	21	13	46	9	6.75	6.2
65704.W0008	Right	8	42	M8	24	25	14	54	12	9.00	10.3
65704.W0010	Right	10	48	M10	28	28	13	62	14	10.50	14.4
65704.W0012	Right	12	54	M12	32	32	13	70	16	12.00	19.2
65704.W0016	Right	16	66	M16	42	37	15	87	21	15.00	31.2
65704.W0505	Left	5	33	M5	18	19	13	42	8	6.00	3.9
65704.W0506	Left	6	36	M6	20	21	13	46	9	6.75	6.0
65704.W0508	Left	8	42	M8	24	25	14	54	12	9.00	10.0
65704.W0510	Left	10	48	M10	28	28	13	62	14	10.50	16.0
65704.W0512	Left	12	54	M12	32	32	13	70	16	12.00	23.0
65704.W0516	Left	16	66	M16	42	37	15	87	21	15.00	44.0

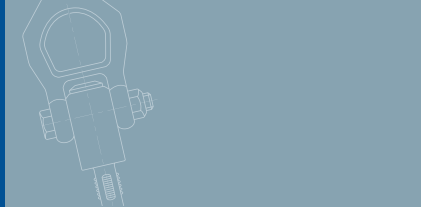

Parts overview



Heavy Duty Rod Ends: integral spherical plain bearings - series K and series E
 Male and female rod ends, maintenance free. These are our most popular range of heavy duty rod ends. Bore diameters 5mm up to 30mm.

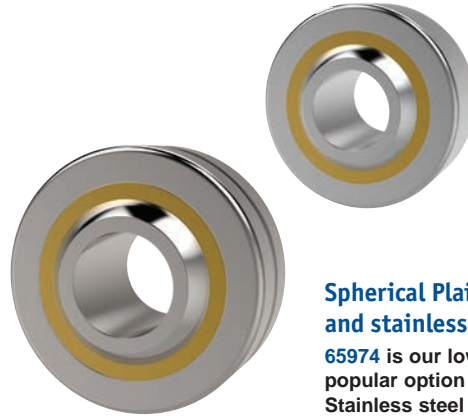

Spherical Plain Bearings: steel and stainless steel
 65974 is our lowest cost, most popular option spherical bearing. Stainless steel version 65976 requires maintenance. 65974 is maintenance free. Bore diameters 5mm up to 30mm.



Heavy Duty Rod Ends: integral ball bearings - series K and series E
 Male and female rod ends. Different bore sizes in relation to the thread size. All require maintenance. Bore diameters 6mm up to 30mm.

Stainless Steel Heavy Duty Rod Ends: integral spherical plain bearings
 Male and female rod ends maintenance free.



Low Cost Rod Ends: with spherical plain bearing
 These are our most popular male and female rod ends. Maintenance free. Female-bore diameters 5mm up to 12mm. Male-bore diameters 5mm up to 16mm.



Rod Ends with Studs
 Steel and Stainless steel, male and female, maintenance free. Sizes M6 up to M16.

see our website for our full range:
wixroyd.com

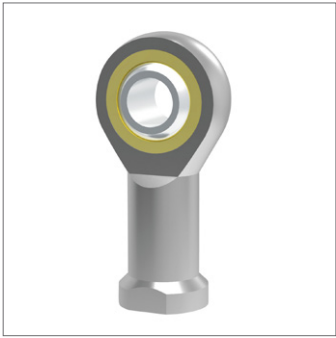

65724

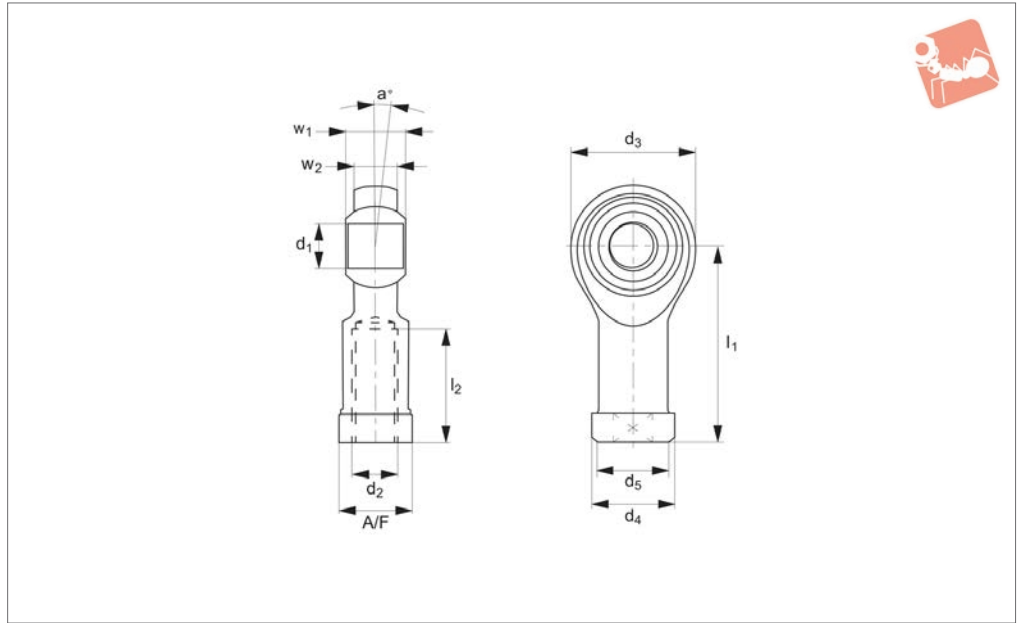

Material

Ball: low carbon steel, surface hardened.
Silver zinc plated.
Housing: low carbon steel, zinc plated for corrosion resistance.

Bearing race: teflon.

Brass bearing with PTFE composite lining.

Technical Notes

Standard thread is right hand thread.

Important Notes

Housing styles are subject to change.

Order No.	Thread hand	d ₁ tol. H7	l ₁	d ₂	d ₃	d ₄	d ₅	l ₂	w ₁	w ₂	A/F	a °	Static load C ₀ kN max.
65724.W0005	Right	5	27	M5	18	11	9	10	8	6	9	13	4.8
65724.W0006	Right	6	30	M6	20	13	10	12	9	6.75	11	13	6.2
65724.W0008	Right	8	36	M8	24	16	12.5	16	12	9	13	14	10.3
65724.W0010	Right	10	43	M10	28	19	15	20	14	10.5	17	13	14.4
65724.W0012	Right	12	50	M12	34	22	17.5	22	16	12	19	13	19.2
65724.W0016	Right	16	64	M16	42	27	22	28	21	15	22	15	31.2
65724.W0505	Left	5	27	M5	18	11	9	10	8	6	9	13	4.8
65724.W0506	Left	6	30	M6	20	13	10	12	9	6.75	11	13	6.2
65724.W0508	Left	8	36	M8	24	16	12.5	16	12	9	13	14	10.3
65724.W0510	Left	10	43	M10	28	19	15	20	14	10.5	17	13	14.4
65724.W0512	Left	12	50	M12	34	22	17.5	22	16	12	19	13	19.2
65724.W0516	Left	16	64	M16	42	27	22	28	21	15	22	15	31.2



Stainless Low Cost Rod Ends

Male

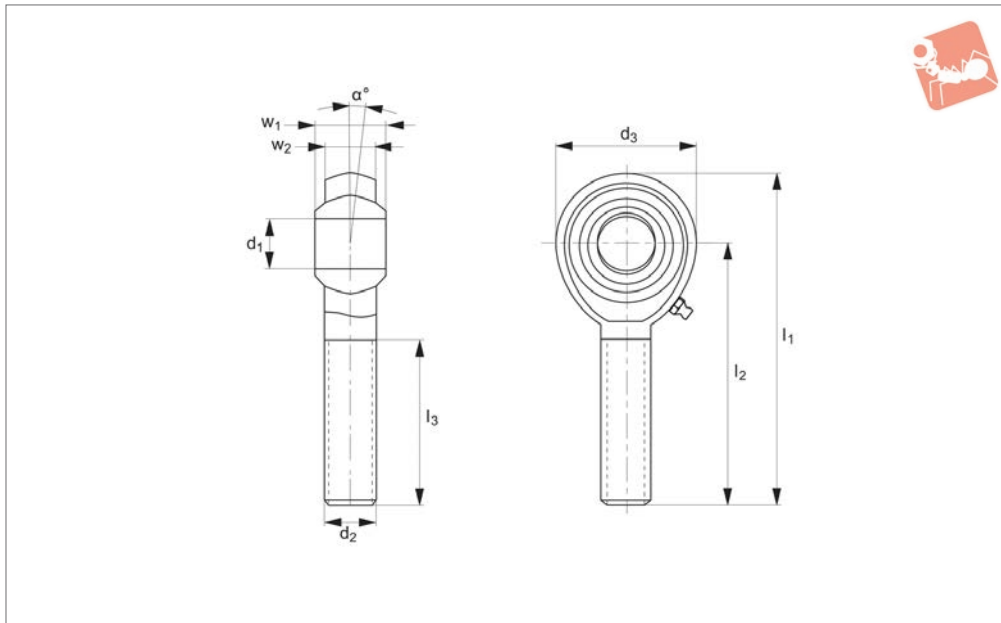
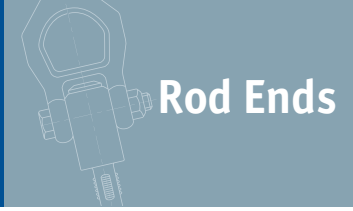

65706

ROD ENDS

Material

Housing: stainless steel (AISI 303)
Ball: stainless steel, hardened, ground and polished.

Race: teflon or PTFE liner.
Stainless steel bearing ring lined with bronze and PTFE Composite

Technical Notes

Standard thread is right hand thread.

Order No.	Thread hand	d ₁ tol. H7	l ₁	d ₂	d ₃	l ₂	α	l ₃	w ₁	w ₂	Static load kN max.	Weight g
65706.W0005	Right	5	42	M5	18	33	13	19	8	6	4.8	13
65706.W0006	Right	6	46	M6	20	36	13	21	9	6.75	6.2	20
65706.W0008	Right	8	54	M8	24	42	14	25	12	9	10.3	38
65706.W0010	Right	10	62	M10	28	48	13	28	14	10.50	14.4	55
65706.W0012	Right	12	70	M12	32	54	13	32	16	12	19.2	85
65706.W0505	Left	5	42	M5	18	33	13	19	8	6	4.8	13
65706.W0506	Left	6	46	M6	20	36	13	21	9	6.75	5.2	20
65706.W0508	Left	8	54	M8	24	42	14	25	12	9	7.0	38
65706.W0510	Left	10	62	M10	28	48	13	28	14	10.50	10.4	55
65706.W0512	Left	12	70	M12	32	54	13	32	16	12	13.0	85



65726

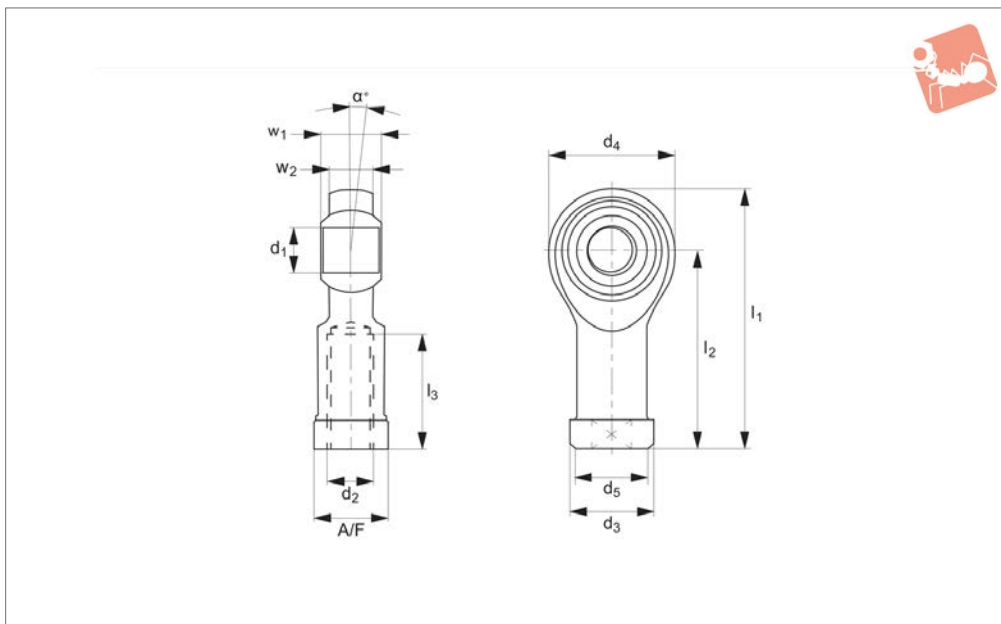

Material

Housing: stainless steel (AISI 303)

Ball: Stainless steel, hardened ground and

polished stainless steel bearing rings

series K, maintenance free.

Technical Notes

Standard thread is right hand thread,

Order No.	Thread hand	d ₁ tol. H7	l ₁	d ₂	d ₃	d ₄	d ₅	l ₂	l ₃	w ₁	w ₂	A/F	α°	Static load C ₀ kN max.	Weight g
65726.W0005	Right	5	36	M 5	18	11	8.5	27	10	8	6.00	9	13	4.8	16
65726.W0006	Right	6	40	M 6	20	13	10	30	12	9	6.75	11	13	6.2	22
65726.W0008	Right	8	48	M 8	16	24	12.5	36	16	12	9.00	14	14	10.3	47
65726.W0010	Right	10	57	M10	28	19	15	43	20	14	10.50	17	13	14.4	77
65726.W0012	Right	12	66	M12	32	22	17.5	50	22	16	12.00	19	13	19.2	100
65726.W0016	Right	16	85	M16	42	27	22	64	28	21	15.00	22	15	31.2	220
65726.W0505	Left	5	36	M 5	18	11	8.5	27	10	8	6.00	9	13	4.8	16
65726.W0506	Left	6	40	M 6	20	13	10	30	12	9	6.75	11	13	6.2	22
65726.W0508	Left	8	48	M 8	16	24	12.5	36	16	12	9.00	14	14	10.3	47
65726.W0510	Left	10	57	M10	28	19	15	43	20	14	10.50	17	13	14.4	77
65726.W0512	Left	12	66	M12	32	22	17.5	50	22	16	12.00	19	13	19.2	100
65726.W0516	Left	16	85	M16	42	27	22	64	28	21	15.00	22	15	31.2	220



Heavy-Duty Rod Ends - Male with integral spherical plain bearing

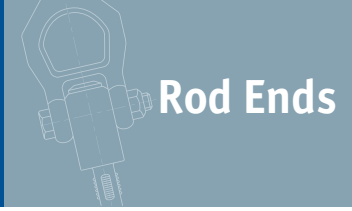

Rod Ends

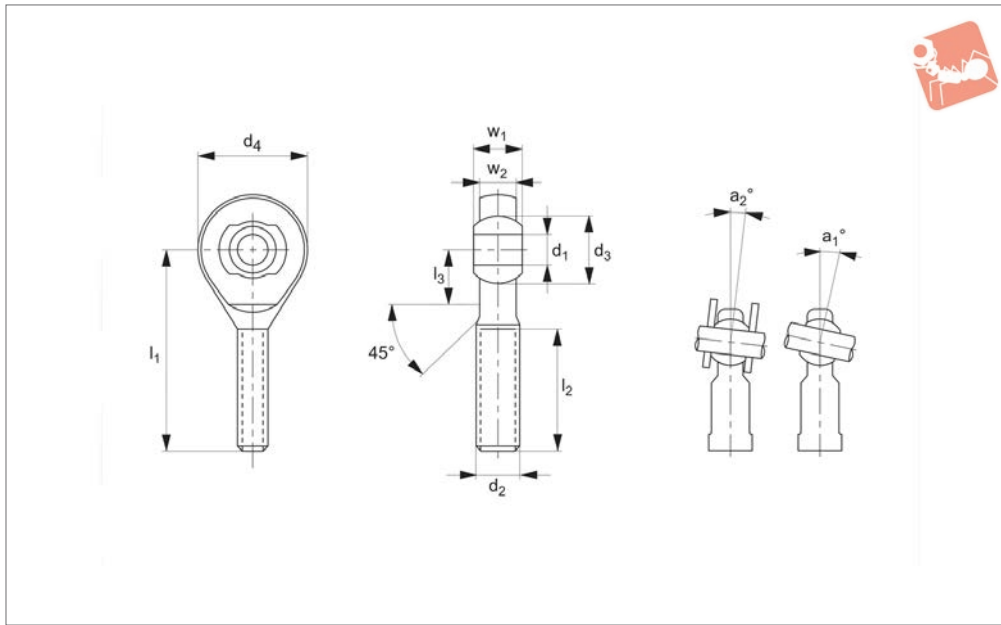

65700

ROD ENDS

Material

Housing - forged steel, tempered, rolled thread, surface galvanized.

Joint ball - ball bearing steel, hardened and ground.

Race - nylon/teflon/glass compound.

Technical Notes

Maintenance free, sizes according to DIN ISO 12240-4, series K, for tolerances see technical pages.

Tips

Standard thread is right hand thread.

Important Notes

*Denotes fine pitch thread.

Order No.	Thread hand	d ₁	l ₁	d ₂	d ₃	l ₂	d ₄	a ₁	Weight g
65700.W0005	Right	5	33	M5	11.11	20	18	13.0	14
65700.W0006	Right	6	36	M6	12.70	22	20	13.0	20
65700.W0008	Right	8	42	M8	15.87	25	24	14.5	38
65700.W0010	Right	10	48	M10	19.05	29	28	13.5	60
65700.W0012	Right	12	54	M12	22.22	33	32	13.0	92
65700.W0014	Right	14	60	M14	25.40	36	36	16.0	127
65700.W0016	Right	16	66	M16	28.57	40	42	15.5	202
65700.W0018	Right	18	72	M18x1,5*	31.75	44	46	15.0	250
65700.W0020	Right	20	78	M20x1,5*	34.92	47	50	14.5	327
65700.W0022	Right	22	84	M22x1,5*	38.10	51	54	15.5	440
65700.W0025	Right	25	94	M24x2*	42.85	57	60	15.0	630
65700.W0030	Right	30	110	M30x2*	50.75	66	70	17.0	1015
65700.W0505	Left	5	33	M5	11.11	20	18	13.0	14
65700.W0506	Left	6	36	M6	12.70	22	20	13.0	20
65700.W0508	Left	8	42	M8	15.87	25	24	14.5	38
65700.W0510	Left	10	48	M10	19.05	29	28	13.5	60
65700.W0512	Left	12	54	M12	22.22	33	32	13.0	92
65700.W0514	Left	14	60	M14	25.40	36	36	16.0	127
65700.W0516	Left	16	66	M16	28.57	40	42	15.5	202
65700.W0518	Left	18	72	M18x1,5*	31.75	44	46	15.0	250
65700.W0520	Left	20	78	M20x1,5*	34.92	47	50	14.5	327
65700.W0522	Left	22	84	M22x1,5*	38.10	51	54	15.5	440
65700.W0525	Left	25	94	M24x2*	42.85	57	60	15.0	630
65700.W0530	Left	30	110	M30x2*	50.80	66	70	17.0	1015

Order No.	a ₂	l ₃	w ₁	w ₂	Dyn. load C kN max.	Static load C ₀ kN max.
65700.W0005	7.5	9	8	6.00	3.9	5.6
65700.W0006	6.5	12	9	6.75	4.6	7.8
65700.W0008	7.5	15	12	9.00	7.0	14.3
65700.W0010	8.0	15	14	10.50	10.4	22.6

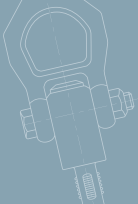

Heavy-Duty Rod Ends - Male with integral spherical plain bearing



ROD ENDS

Order No.	a_2	l_3	w_1	w_2	Dyn. load C kN max.	Static load C_0 kN max.
65700.W0012	8.0	19	16	12.00	12.4	32.8
65700.W0014	9.5	20	19	13.50	15.4	41.3
65700.W0016	8.5	22	21	15.00	22.4	56.6
65700.W0018	9.5	25	23	16.50	26.3	69.7
65700.W0020	9.0	28	25	18.00	30.8	82.2
65700.W0022	10.0	26	28	20.00	38.2	95.6
65700.W0025	10.0	30	31	22.00	45.3	118.6
65700.W0030	10.5	35	37	25.00	55.0	145.6
65700.W0505	7.5	9	8	6.00	3.9	5.6
65700.W0506	6.5	12	9	6.75	4.6	7.8
65700.W0508	7.5	15	12	9.00	7.0	14.3
65700.W0510	8.0	15	14	10.50	10.4	22.6
65700.W0512	8.0	19	16	12.00	12.4	32.8
65700.W0514	9.5	20	19	13.50	15.4	41.3
65700.W0516	8.5	22	21	15.00	22.4	56.6
65700.W0518	9.5	25	23	16.50	26.325	69.700
65700.W0520	9.0	28	25	18.00	30.805	82.200
65700.W0522	10.0	26	28	20.00	38.2	95.6
65700.W0525	10.0	30	31	22.00	45.3	118.6
65700.W0530	10.5	35	37	25.00	55.0	145.6



Stainless Heavy-Duty Rod Ends - Male

with integral spherical plain bearing

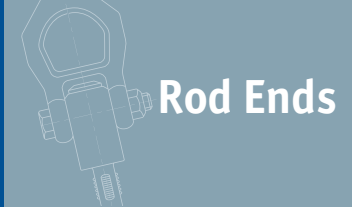

Rod Ends

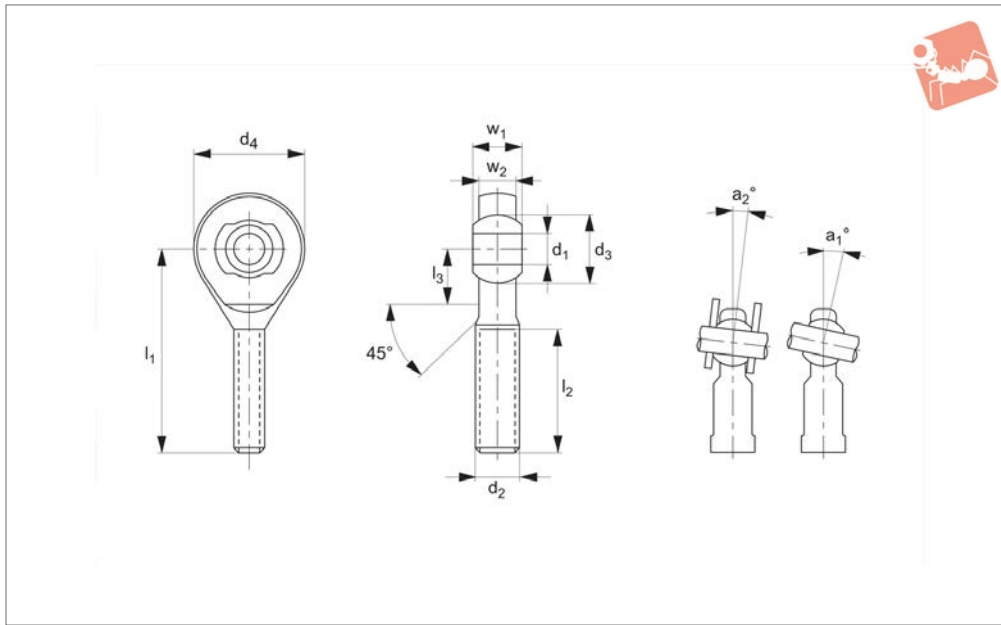

65702

ROD ENDS

Material

Rod end housing: Stainless steel DIN 1.4301 (AISI 304), forged, rolled thread
 Joint ball: Stainless steel 1.4412, hardened and ground, surface polished.
 Race: Nylon/Teflon/glass compound.

Technical Notes

Maintenance free, for tolerances see technical

page 123, standard thread is right hand thread.

Tips

A2 stainless steel provides good corrosion resistance to a wide range of atmospheric conditions and corrosive media. It is considered resistant to potable water.

Important Notes

*Denotes fine pitch thread.

Order No.	Thread hand	d ₁	l ₁	d ₂	d ₃	l ₂	d ₄	a ₁ °	Weight g
65702.W0005	Right	5	33	M5	11.11	20	18	13.0	14
65702.W0006	Right	6	36	M6	12.70	22	20	13.0	20
65702.W0008	Right	8	42	M8	15.87	25	24	14.5	38
65702.W0010	Right	10	48	M10	19.05	29	28	13.5	60
65702.W0012	Right	12	54	M12	22.22	33	32	13.0	92
65702.W0014	Right	14	60	M14	25.40	36	36	16.0	127
65702.W0016	Right	16	66	M16	28.57	40	42	15.5	202
65702.W0018	Right	18	72	M18x1,5*	31.75	44	46	15.0	250
65702.W0020	Right	20	78	M20x1,5*	34.92	47	50	14.5	327
65702.W0022	Right	22	84	M22x1,5*	38.10	51	54	15.5	440
65702.W0025	Right	25	94	M24x2*	42.85	57	60	15.0	630
65702.W0030	Right	30	110	M30x2*	50.80	66	70	17.0	1015
65702.W0505	Left	5	33	M5	11.11	20	18	13.0	14
65702.W0506	Left	6	36	M6	12.70	22	20	13.0	20
65702.W0508	Left	8	42	M8	15.87	25	24	14.5	38
65702.W0510	Left	10	48	M10	19.05	29	28	13.5	60
65702.W0512	Left	12	54	M12	22.22	33	32	13.0	92
65702.W0514	Left	14	60	M14	25.40	36	36	16.0	127
65702.W0516	Left	16	66	M16	28.57	40	42	15.5	202
65702.W0518	Left	18	72	M18x1,5*	31.75	44	46	15.0	250
65702.W0522	Left	22	84	M22x1,5*	38.10	51	54	15.5	440
65702.W0525	Left	25	94	M24x2*	42.85	57	60	15.0	630
65702.W0530	Left	30	110	M30x2*	50.80	66	70	17.0	1015

Order No.	a ₂ °	l ₃	w ₁	w ₂	Dyn. load C kN max.	Static load C ₀ kN max.
65702.W0005	7.5	9	8	6.00	3.9	3.9
65702.W0006	6.5	12	9	6.75	4.6	5.4

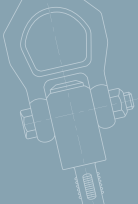

Stainless Heavy-Duty Rod Ends - Male with integral spherical plain bearing



ROD ENDS

Order No.	a_2	l_3	w_1	w_2	Dyn. load C kN max.	Static load C_0 kN max.
65702.W0008	7.5	15	12	9.00	7.0	9.7
65702.W0010	8.0	15	14	10.50	10.4	15.4
65702.W0012	8.0	19	16	12.00	12.4	22.3
65702.W0014	9.5	20	19	13.50	15.4	30.4
65702.W0016	8.5	22	21	15.00	22.4	41.5
65702.W0018	9.5	25	23	16.50	26.3	51.2
65702.W0020	9.0	28	25	18.00	30.8	60.3
65702.W0022	10.0	26	28	20.00	38.2	70.0
65702.W0025	10.0	30	31	22.00	45.4	87.0
65702.W0030	10.5	35	37	25.00	55.0	106.8
65702.W0505	7.5	9	8	6.00	3.9	3.9
65702.W0506	6.5	12	9	6.75	4.6	5.4
65702.W0508	7.5	15	12	9.00	7.0	9.7
65702.W0510	8.0	15	14	10.50	10.4	15.4
65702.W0512	8.0	19	16	12.00	12.4	22.3
65702.W0514	9.5	20	19	13.50	15.4	30.4
65702.W0516	8.5	22	21	15.00	22.4	41.5
65702.W0518	9.5	25	23	16.50	26.3	51.2
65702.W0522	10.0	26	28	20.00	38.2	70.0
65702.W0525	10.0	30	31	22.00	45.4	87.0
65702.W0530	10.5	35	37	25.00	55.0	106.8



Heavy-Duty Rod Ends - Male with integral ball bearing

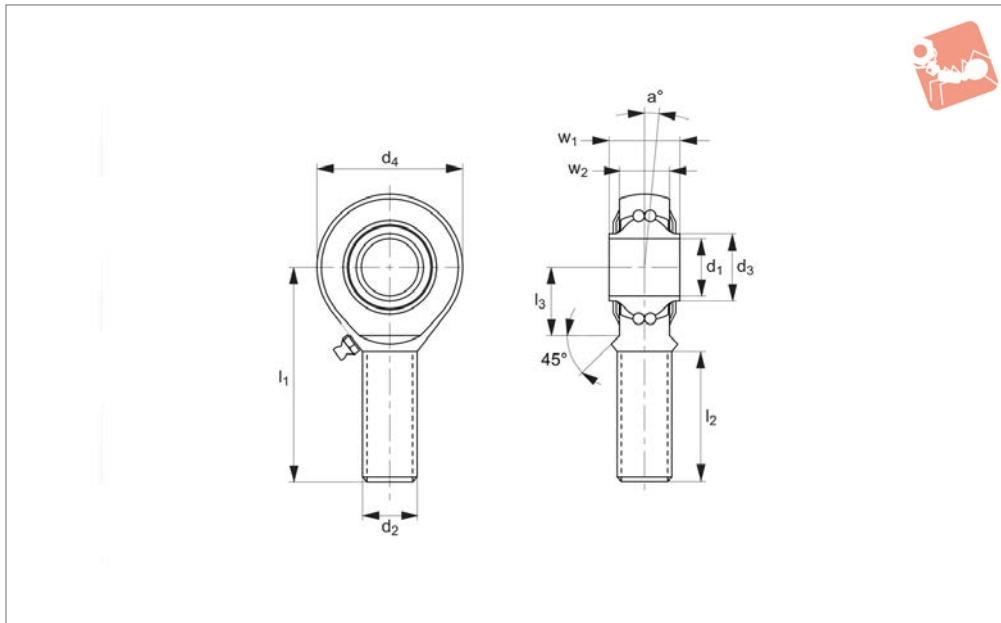
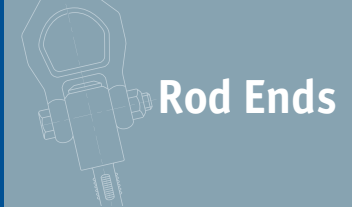

65740

ROD ENDS

Material

Housing - forged steel, tempered, case hardened bearing race, ground and lapped, rolled thread, surface galvanized.
Inner ring - ball bearing steel, hardened, superfine ground, lubrication - calcium-complex-soap-grease, temp range -20°C to +120°C.

Lubrication nipple - DIN 3405 D1/A (sizes 6 to 10) DIN 71412 H1 (sizes 12 to 30).

technical pages.

Tips

Standard thread is right hand thread.

Technical Notes

Low maintenance. Sizes according to DIN ISO 12240-4 series K, for tolerances see

Important Notes

*Denotes fine pitch thread.

Order No.	Thread hand	d ₁	l ₁	d ₂	d ₃	l ₂	d ₄	a	l ₃	w ₁	Weight g
65740.W0106	Right	6	36	M6	9.0	22	20	8.0	12	9	19
65740.W0108	Right	8	42	M8	10.5	25	24	8.5	15	12	36
65740.W0110	Right	10	48	M10	12.0	29	28	8.0	15	14	60
65740.W0112	Right	12	54	M12	14.5	33	32	7.5	19	16	87
65740.W0114	Right	14	60	M14	17.0	36	36	6.0	20	19	135
65740.W0116	Right	16	66	M16	19.0	40	42	8.0	22	21	190
65740.W0118	Right	18	72	M18x1,5*	21.5	44	46	8.5	25	23	270
65740.W0120	Right	20	78	M20x1,5*	24.5	47	50	7.0	28	25	338
65740.W0122	Right	22	84	M22x1,5*	26.0	51	54	8.0	26	28	450
65740.W0125	Right	25	94	M24x2*	29.5	57	64	5.0	30	31	602
65740.W0130	Right	30	110	M30x2*	34.5	66	70	7.5	35	37	922
65740.W0206	Left	6	36	M6	9.0	22	20	8.0	12	9	19
65740.W0208	Left	8	42	M8	10.5	25	24	8.5	15	12	36
65740.W0210	Left	10	48	M10	12.0	29	28	8.0	15	14	60
65740.W0212	Left	12	54	M12	14.5	33	32	7.5	19	16	87
65740.W0214	Left	14	60	M14	17.0	36	36	6.0	20	19	135
65740.W0216	Left	16	66	M16	19.0	40	42	8.0	22	21	190
65740.W0218	Left	18	72	M18x1,5*	21.5	44	46	8.5	25	23	270
65740.W0220	Left	20	78	M20x1,5*	24.5	47	50	7.0	28	25	338
65740.W0222	Left	22	84	M22x1,5*	26.0	51	54	8.0	26	28	450
65740.W0225	Left	25	94	M24x2*	29.5	57	64	5.0	30	31	602
65740.W0230	Left	30	110	M30x2*	34.5	66	70	7.5	35	37	922

Order No.	w ₂	Calc. factor Y	Calc. factor Y ₀	Dyn. load C kN max.	Speed rpm max.	Static load C ₀ kN max.
65740.W0106	6.75	2.19	2.09	2.75	1350	0.65
65740.W0108	9.00	1.89	1.80	4.00	1300	1.00
65740.W0110	10.50	1.81	1.90	4.45	1225	1.45

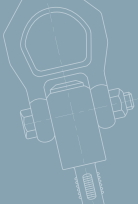

Order No.	w ₂	Calc. factor Y	Calc. factor Y ₀	Dyn. load C kN max.	Speed rpm max.	Static load C ₀ kN max.
65740.W0112	12.00	1.82	1.74	4.95	1125	1.80
65740.W0114	13.50	2.48	2.36	5.60	1025	2.00
65740.W0116	15.00	2.35	2.24	6.25	975	2.35
65740.W0118	16.50	2.31	2.21	7.10	900	2.90
65740.W0120	18.00	2.58	2.46	7.90	825	3.45
65740.W0122	20.00	2.24	2.35	9.30	725	3.98
65740.W0125	22.00	2.12	2.02	11.03	600	5.68
65740.W0130	25.00	2.35	2.24	14.15	450	7.45
65740.W0206	6.75	2.19	2.09	2.75	1350	0.65
65740.W0208	9.00	1.89	1.80	4.00	1300	1.00
65740.W0210	10.50	1.81	1.90	4.45	1225	1.45
65740.W0212	12.00	1.82	1.74	4.95	1125	1.80
65740.W0214	13.50	2.48	2.36	5.60	1025	2.00
65740.W0216	15.00	2.35	2.24	6.25	975	2.35
65740.W0218	16.50	2.31	2.21	7.10	900	2.90
65740.W0220	18.00	2.58	2.46	7.90	825	3.45
65740.W0222	20.00	2.24	2.35	9.30	725	3.98
65740.W0225	22.00	2.12	2.02	11.03	600	5.68
65740.W0230	25.00	2.35	2.24	14.15	450	7.45



Heavy-Duty Rod Ends - Male with integral ball bearing

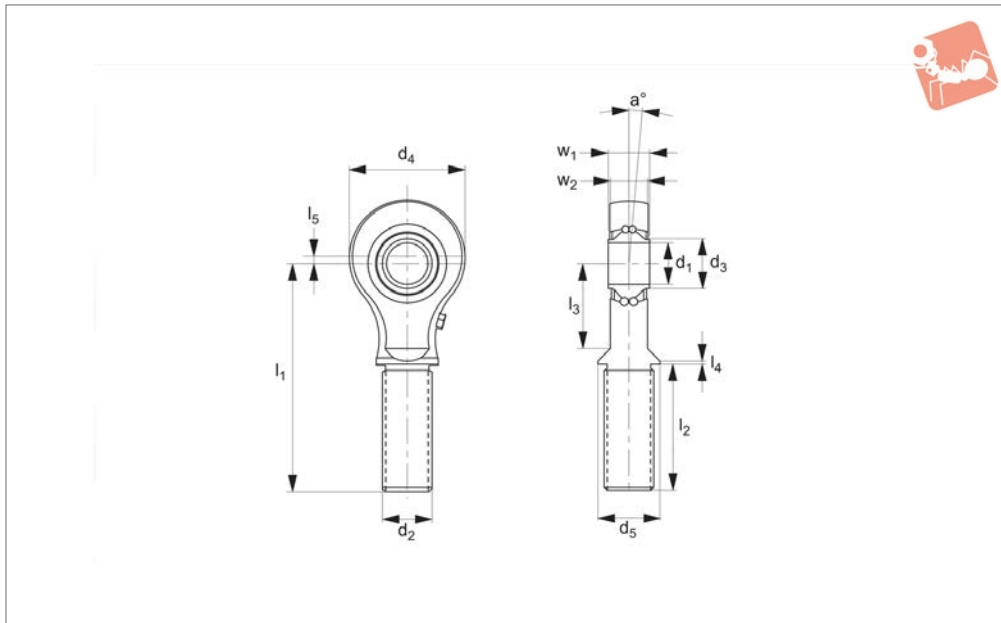
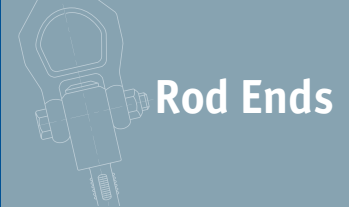

65820

ROD ENDS

Material

Housing - forged steel, tempered, case hardened bearing race, ground and lapped, surface galvanized.

Inner ring - ball bearing steel, hardened, superfine ground.

Lubrication - calcium-complex-soap-

grease, temp range -20°C to +120°C, lubrication nipple - DIN 3405 D1/A.

Technical Notes

Low maintenance, for tolerances see technical pages.

Tips

Standard thread is right hand thread.

Important Notes

*Denotes fine pitch thread.

Order No.	Thread hand	d ₁	l ₁	d ₂	d ₃	l ₂	d ₄	d ₅	a	l ₃	Weight g
65820.W0006	Right	6	64.0	M10x1	8.5	42.5	24	14	10.5	17	62
65820.W0007	Right	6	40.5	M10x1	8.5	19	24	14	10.5	17	57
65820.W0008	Right	8	72.0	M12x1.5	11.0	46.5	30	17	8.5	20	97
65820.W0009	Right	8	48.5	M12x1.5	11.0	23	30	17	8.5	20	88
65820.W0010	Right	10	82.0	M14x1.5	13.5	49.5	36	19	9.5	28	168
65820.W0011	Right	10	58.5	M14x1.5	13.5	26	36	19	9.5	28	154
65820.W0012	Right	12	90.0	M16x1.5	15.0	53.5	40	21	7.5	31	226
65820.W0013	Right	12	65.5	M16x1.5	15.0	29	40	21	7.5	31	204
65820.W0015	Right	15	100.0	M20x1.5	18.5	62.5	42	26	6.5	30	310
65820.W0016	Right	15	73.5	M20x1.5	18.5	36	42	26	6.5	30	273
65820.W0017	Right	17	105.0	M20x1.5	21.0	62.5	48	26	7.0	36	401
65820.W0018	Right	17	78.5	M20x1.5	21.0	36	48	26	7.0	36	354
65820.W0020	Right	20	117.0	M24x1.5	24.0	68.5	56	30	5.5	41	587
65820.W0021	Right	20	89.5	M24x1.5	24.0	41	56	30	5.5	41	519
65820.W0506	Left	6	64.0	M10x1	8.5	42.5	24	14	10.5	17	62
65820.W0507	Left	6	40.5	M10x1	8.5	19	24	14	10.5	17	57
65820.W0508	Left	8	72.0	M12x1.5	11.0	46.5	30	17	8.5	20	97
65820.W0509	Left	8	48.5	M12x1.5	11.0	23	30	17	8.5	20	88
65820.W0510	Left	10	82.0	M14x1.5	13.5	49.5	36	19	9.5	28	168
65820.W0511	Left	10	58.5	M14x1.5	13.5	26	36	19	9.5	28	154
65820.W0512	Left	12	90.0	M16x1.5	15.0	53.5	40	21	7.5	31	226
65820.W0513	Left	12	65.5	M16x1.5	15.0	29	40	21	7.5	31	204
65820.W0515	Left	15	100.0	M20x1.5	18.5	62.5	42	26	6.5	30	310
65820.W0516	Left	15	73.5	M20x1.5	18.5	36	42	26	6.5	30	273
65820.W0517	Left	17	105.0	M20x1.5	21.0	62.5	48	26	7.0	36	401
65820.W0518	Left	17	78.5	M20x1.5	21.0	36	48	26	7.0	36	354
65820.W0520	Left	20	117.0	M24x1.5	24.0	68.5	56	30	5.5	41	587
65820.W0521	Left	20	89.5	M24x1.5	24.0	41	56	30	5.5	41	519

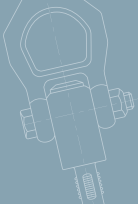

Order No.	l_4	l_5	w_1	w_2	Calc. factor Y	Calc. factor Y_0	Dyn. load C kN max.	Speed rpm max.	Static load C_0 kN max.
65820.W0006	2.5	1.5	14	10	1.28	1.34	2.44	1300	0.76
65820.W0007	2.5	1.5	14	10	1.28	1.34	2.44	1300	0.76
65820.W0008	2.5	2.0	15	10	1.9	1.81	2.60	1225	0.98
65820.W0009	2.5	2.0	15	10	1.9	1.81	2.60	1225	0.98
65820.W0010	2.5	2.5	20	14	1.69	1.77	5.12	1100	1.90
65820.W0011	2.5	2.5	20	14	1.69	1.77	5.12	1100	1.90
65820.W0012	2.5	3.0	20	14	1.81	1.90	5.34	1050	2.06
65820.W0013	2.5	3.0	20	14	1.81	1.90	5.34	1050	2.06
65820.W0015	2.5	3.0	20	14	2.07	2.17	5.48	975	3.27
65820.W0016	2.5	3.0	20	14	2.07	2.17	5.48	975	3.27
65820.W0017	2.5	3.5	22	16	2.35	2.46	5.57	875	2.68
65820.W0018	2.5	3.5	22	16	2.35	2.46	5.57	875	2.68
65820.W0020	3.0	3.5	24	18	2.76	2.90	6.16	775	3.14
65820.W0021	3.0	3.5	24	18	2.76	2.90	6.16	775	3.14
65820.W0506	2.5	1.5	14	10	1.28	1.34	2.44	1300	0.76
65820.W0507	2.5	1.5	14	10	1.28	1.34	2.44	1300	0.76
65820.W0508	2.5	2.0	15	10	1.9	1.81	2.60	1225	0.98
65820.W0509	2.5	2.0	15	10	1.9	1.81	2.60	1225	0.98
65820.W0510	2.5	2.5	20	14	1.69	1.77	5.12	1100	1.90
65820.W0511	2.5	2.5	20	14	1.69	1.77	5.12	1100	1.90
65820.W0512	2.5	3.0	20	14	1.81	1.90	5.34	1050	2.06
65820.W0513	2.5	3.0	20	14	1.81	1.90	5.34	1050	2.06
65820.W0515	2.5	3.0	20	14	2.07	2.17	5.48	975	3.27
65820.W0516	2.5	3.0	20	14	2.07	2.17	5.48	975	2.68
65820.W0517	2.5	3.5	22	16	2.35	2.46	5.57	875	2.68
65820.W0518	2.5	3.5	22	16	2.35	2.46	5.57	875	2.68
65820.W0520	3.0	3.5	24	18	2.76	2.90	6.16	775	3.14
65820.W0521	3.0	3.5	24	18	2.76	2.90	6.16	775	3.14



Heavy-Duty Rod Ends - Male with integral spherical plain bearing

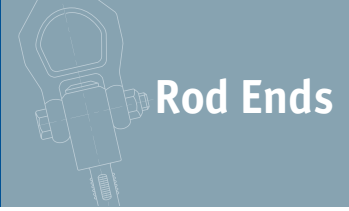

Rod Ends

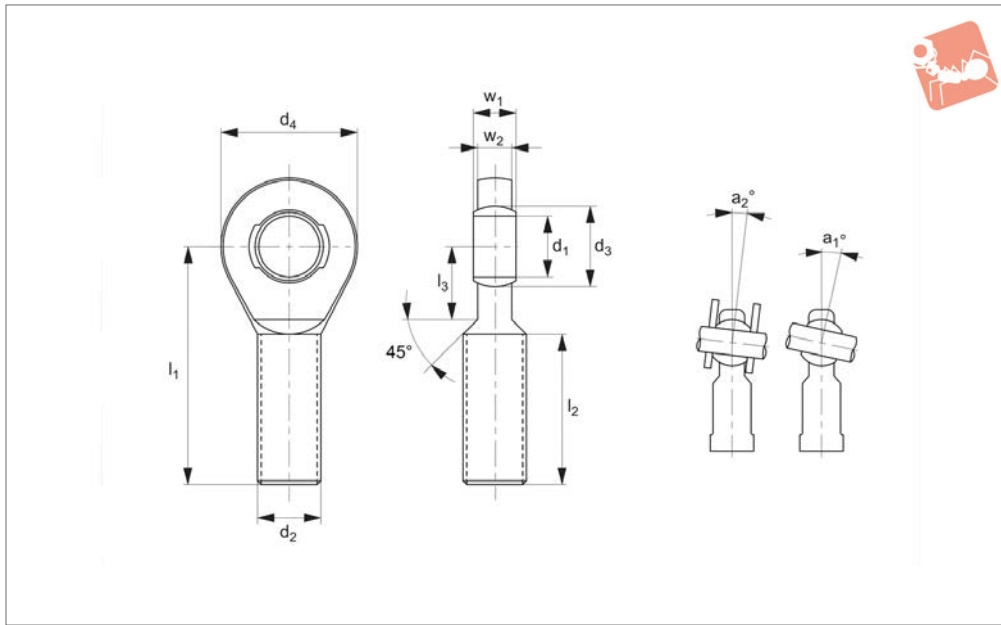

65860

ROD ENDS

Material

Housing - forged steel, tempered, rolled thread, surface galvanized.

Joint ball - ball bearing steel, hardened and ground, surface superfinished and chromium plated.

Race - nylon/teflon/glass compound.

Technical Notes

Maintenance free, sizes according to DIN ISO 12240-4, series E, for tolerances tech-

nical pages.

Tips

Standard thread is right hand thread.

Important Notes

*Denotes fine pitch thread.

Order No.	Thread hand	d ₁	l ₁	d ₂	d ₃	l ₂	d ₄	a ₁	Weight g
65860.W0006	Right	6	36	M6	10.0	22	20	13.0	14
65860.W0008	Right	8	42	M8	13.0	25	23	15.0	24
65860.W0010	Right	10	48	M10	16.0	29	28	12.0	41
65860.W0012	Right	12	54	M12	18.0	33	32	10.5	67
65860.W0015	Right	15	63	M14	22.0	33	38	8.5	110
65860.W0017	Right	17	69	M16	25.0	40	44	10.0	163
65860.W0020	Right	20	78	M20x1,5*	29.0	47	51	9.0	270
65860.W0025	Right	25	94	M24x2*	35.5	57	62	7.5	508
65860.W0030	Right	30	110	M30x2*	40.7	66	70	6.0	785
65860.W0035	Right	35	140	M36x3*	47.0	92	82	6.5	1330
65860.W0040	Right	40	145	M42x3*	53.0	94	92	7.0	1890
65860.W0041	Right	40	150	M39x3*	53.0	99	92	7.0	1785
65860.W0045	Right	45	165	M45x3*	60.0	100	102	7.5	2620
65860.W0046	Right	45	163	M42x3*	60.0	98	102	7.5	2430
65860.W0050	Right	50	195	M52x3*	66.0	120	112	6.5	3865
65860.W0051	Right	50	185	M45x3*	66.0	110	112	6.5	3225
65860.W0060	Right	60	225	M60x4*	80.0	140	135	6.5	6400
65860.W0061	Right	60	210	M60x4*	80.0	125	-	6.5	5430
65860.W0506	Left	6	36	M6	10.0	22	20	13.0	14
65860.W0508	Left	8	42	M8	13.0	25	23	15.0	24
65860.W0510	Left	10	48	M10	16.0	29	28	12.0	41
65860.W0512	Left	12	54	M12	18.0	33	32	10.5	67
65860.W0515	Left	15	63	M14	22.0	33	38	8.5	110
65860.W0517	Left	17	69	M16	25.0	40	44	10.0	163
65860.W0520	Left	20	78	M20x1,5*	29.0	47	51	9.0	270
65860.W0525	Left	25	94	M24x2*	35.5	57	62	7.5	508
65860.W0530	Left	30	110	M30x2*	40.7	66	70	6.0	785
65860.W0535	Left	35	140	M36x3*	47.0	92	82	6.5	1330
65860.W0540	Left	40	145	M42x3*	53.0	94	92	7.0	1890
65860.W0541	Left	40	150	M39x3*	53.0	99	92	7.0	1785
65860.W0545	Left	45	165	M45x3*	60.0	100	102	7.5	2620
65860.W0546	Left	45	163	M42x3*	60.0	98	102	7.5	2430

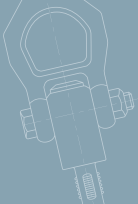

Order No.	Thread hand	d ₁	l ₁	d ₂	d ₃	l ₂	d ₄	a ₁	Weight g
65860.W0550	Left	50	195	M52x3,0*	66.0	120	112	6.5	3865
65860.W0551	Left	50	185	M45x3,0*	66.0	110	112	6.5	3225
65860.W0560	Left	60	225	M60x4,0*	80.0	140	135	6.5	6400
65860.W0561	Left	60	210	M52x3,0*	80.0	125	135	6.5	5430

Order No.	a ₂	l ₃	w ₁	w ₂	Dyn. load C kN max.	Static load C ₀ kN max.
65860.W0006	6.5	11	6	4	2.5	6.4
65860.W0008	8.0	12	8	5	4.2	11.0
65860.W0010	6.0	15	9	6	6.4	16.8
65860.W0012	5.0	15	10	7	9.2	23.0
65860.W0015	4.5	18	12	9	13.4	39.6
65860.W0017	5.5	23	14	10	19.2	54.1
65860.W0020	4.5	25	16	12	25.2	76.7
65860.W0025	3.5	32	20	16	42.4	119.1
65860.W0030	3.0	35	22	18	54.0	141.8
65860.W0035	3.5	38	25	20	70.4	180.8
65860.W0040	3.5	42	28	22	86.0	222.6
65860.W0041	3.5	42	28	22	86.0	222.6
65860.W0045	4.0	50	32	25	107.0	276.2
65860.W0046	4.0	50	32	25	107.0	276.2
65860.W0050	3.0	60	35	28	132.0	339.2
65860.W0051	3.0	60	35	28	132.0	339.2
65860.W0060	3.5	70	44	36	208.0	532.1
65860.W0061	3.5	70	44	36	208.0	532.1
65860.W0506	6.5	11	6	4	2.5	6.4
65860.W0508	8.0	12	8	5	4.2	11.0
65860.W0510	6.0	15	9	6	6.4	16.8
65860.W0512	5.0	15	10	7	9.2	23.0
65860.W0515	4.5	18	12	9	13.4	39.6
65860.W0517	5.5	23	14	10	19.2	54.1
65860.W0520	4.5	25	16	12	25.2	76.7
65860.W0525	3.5	32	20	16	42.4	119.1
65860.W0530	3.0	35	22	18	54.0	141.8
65860.W0535	3.5	38	25	20	70.4	180.8
65860.W0540	3.5	42	28	22	86.0	222.6
65860.W0541	3.5	42	28	22	86.0	222.6
65860.W0545	4.0	50	32	25	107.0	276.2
65860.W0546	4.0	50	32	25	107.0	276.2
65860.W0550	3.0	60	35	28	132.0	339.2
65860.W0551	3.0	60	35	28	132.0	339.2
65860.W0560	3.5	70	44	36	208.0	532.1
65860.W0561	3.5	70	44	36	208.0	532.1



All of our rod ends incorporate either a plain spherical bearing, ball bearing, or roller bearing. Below is an overview of each type.

- ① Thin coating made from Polyamid-PTFE-fibreglass - compound, maintenance free, absorbs any foreign particles.
- ② Ball made of bearing steel, hardened, ground, polished and hard chromium plated, ensures reliable corrosion protection.
- ③ No clearance - radial clearance 0-10µm.
- ④ All rod end housings made of forged steel, tempered, extremely high load resistances.

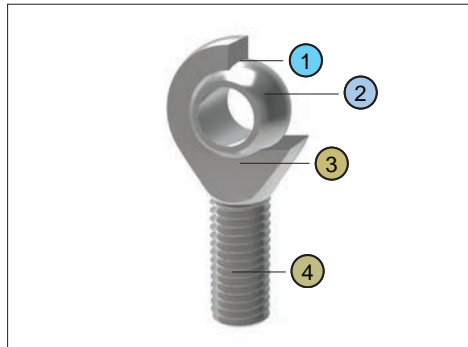

Plain spherical bearings

- ① Radial clearance: 10-30µm, low friction.
- ② Inner ring made of bearing steel, hardened ball grooves polished.
- ③ Shields on both sides protect against rough dirt penetration.
- ④ All rod ends housings are made of forged steel, case hardened bearing race.
- ⑤ Low maintenance due to long-term greasing, especially suitable for high speed large swiveling angles or rotating movements.

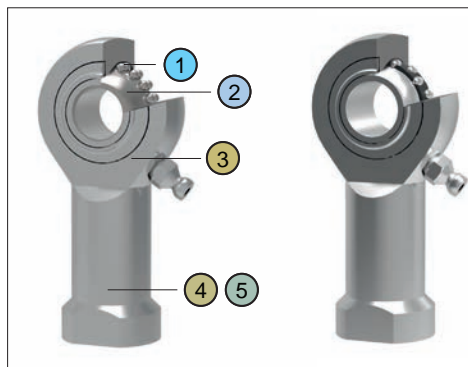

Ball and roller bearings



Rod ends and water

Stainless steel versions

Most of our rod ends are available in stainless steel as standard.

High grade AISI 316 stainless steel available on request.

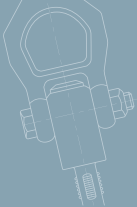

Rod ends with integral maintenance-free spherical plain bearings

In many cases heavy-duty rod ends with integral spherical plain bearings are most often used. They are above all used for small swivelling or tilting movements at low speeds. They stand out for their high load capacity and can also be used for shock-like loads. The rod end ball slides on a plastic bearing shell consisting of a glass fibre-filled nylon/teflon compound. This design assures a maintenance-free rod end. Heavy-duty plain bearing rod ends have slight initial movement friction and virtually no clearance. The plastic material used has another advantage in that it can absorb many foreign particles so that no damage can occur. The balls of heavy-duty rod ends with integral spherical plain bearings are hard chrome plated. This reliable corrosion protection ensures that the function of the rod end will not be affected by a corroded ball surface under humid operating conditions.

Rod ends with integral ball bearings

This design is especially suitable for high speeds, large swivelling angles or rotating movements with relatively low or medium loads. Prominent technical features are the low bearing friction, long-time greasing as well as the sealing against some dirt penetration (by means of shields on both sides). Under normal operating conditions the rod ends are maintenance-free. Greasing nipples are provided for lubrication in case of rough operations and maximum loads. To avoid incompatibility with the production lubrication, we recommend lubrication with a calcium-complex-soap-grease. A special heat treatment procedure gives the rod end housing a raceway hardness adapted to the antifriction bearing, ensuring at the same time high stability with changing loads.

Rod ends with integral roller bearings

This design, based on the structure of a self-aligning roller bearing is preferably used for high speed, large tilting angles or rotating movements under high loads. Compared to rod ends with ball bearings, rod ends with self-aligning roller bearings essentially have higher basic load ratings. This design is equipped with a cage to minimise the rolling friction and heat build-up. These rod ends, with long-time lubrication are under normal operating conditions maintenance-free. Greasing nipples are provided for lubrication in case of rough operations and maximum loads. To avoid incompatibility with the production lubrication, we recommend lubricating with a calcium-complex-soap-grease. Shields on both sides limit dirt particles from penetrating into the bearing. The rod ends with roller bearings are subjected to a special heat treatment to obtain a raceway hardness adapted to the antifriction bearings, ensuring at the same time a high stability with changing loads.

Rod end bearings load capacity explained

Static load capacity C_0 (plain bearings)

The static load capacity C_0 is the radially acting static load which does not cause any permanent deformation of the components when the spherical bearing or rod end is stationary, (i.e. the load condition without pivoting, swivelling or tilting movements). It is also a precondition here that the operating temperature must be at normal room temperature and the surrounding components must possess sufficient stability.

The values specified in the tables are determined by static tension tests on a representative number of series components at 20°C normal room temperature. The static load capacity may vary with lower or higher temperature depending on the material. In the case of all rod ends with plain bearings, the static load rating refers to the maximum permissible static load of the rod end housing in a tensile direction up to which no permanent deformation occurs at the weakest housing cross-section. The value in the product tables has a safety factor of 1.2 times the tensile strength of the rod ends housing material.

Static load capacity C_0 (roller and ball bearings)

For our rod ends with roller and ball bearings, the static load rating is the load at which the bearing can operate at room temperature without its performance being impaired as a result of deformations, fracture, or damage to the sliding contact surfaces (max 1/10,000th of the ball diameter).

Dynamic load capacity C (plain bearings)

Dynamic load ratings serve as values for calculation of the service life of dynamically-loaded spherical bearings and rod ends. The values themselves do not provide any information about the effective dynamic load capacity of the spherical bearing or rod end. To obtain this information, it is necessary to take into account the additional influencing factors such as load type, swivel or tilt angle, speed characteristic, max. permitted bearing clearance, max. permitted bearing friction, lubrication conditions and temperature, etc.

Dynamic load capacities depend on the definition used to calculate them. Comparison of values is not always possible owing to the different definitions used by various manufacturers, and because the load capacities are often determined under completely different test conditions.

Dynamic load capacity C (roller and ball bearings)

For our rod ends with roller and ball bearings, the dynamic load capacity is the load at which 90% of a large quantity of identical rod ends reach 1 million revolutions before they fail (due to fatigue of the rolling surfaces.)



Heavy-duty ball and roller bearing rod ends can be used for operating temperatures between -20°C and $+120^{\circ}\text{C}$. The temperature range of heavy-duty rod ends with integral spherical plain bearing is between -30°C and $+60^{\circ}\text{C}$, without affecting the load capacity. Higher temperatures will reduce the load capacity taken into account for the calculation of the 'working life' under the temperature factor C_2 on page 451.

Operating temperatures

The decisive parameters for the selection and calculation of heavy-duty rod ends are size, direction and type of load.

Loads

The heavy-duty rod ends have been especially designed to cope with high radial loads. They can be used for combined loads, the axial load share of which does not exceed 20% of the corresponding radial load.

Radial or combined loads

In this case the load acts only in the same direction, which means that the load area is always in the same bearing section.

Unilaterally acting load

In case of alternating loads, the load areas facing each other are alternately loaded and/or relieved, which means that the load changes its direction constantly by approximately 180° .

Alternately acting load

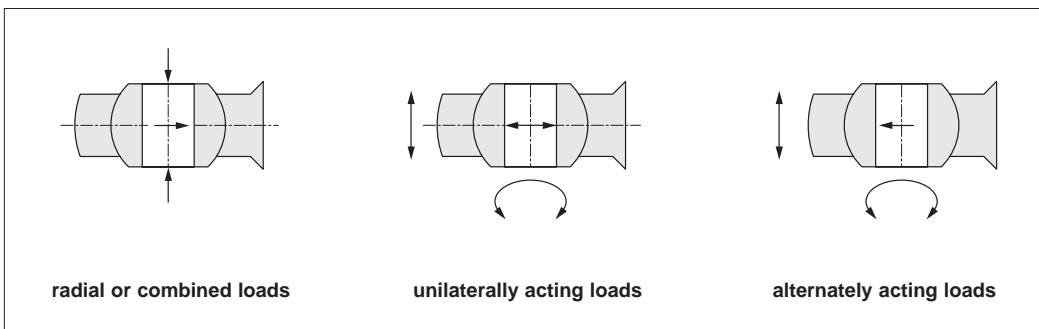

The swivelling angle is the movement of the rod end from one final position to the other. Half the swivelling angle α° is used to calculate the service or 'working life'.

Swivelling angle

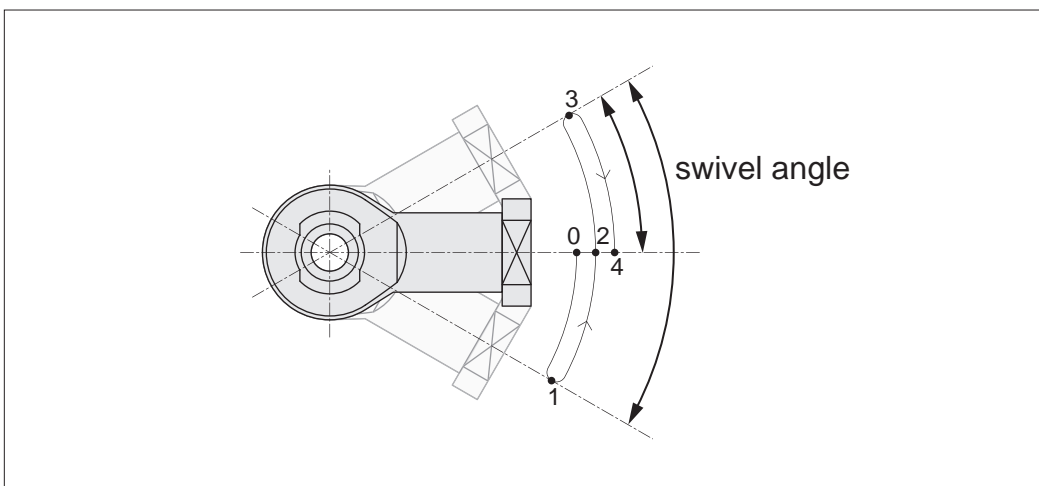

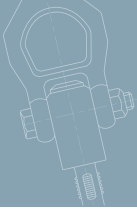

Angle of tilt

The angle of tilt, also called setting angle, refers to the movement of the joint ball and/ or the inner ring to the rod end axis (in degrees). The tilting angle (a) indicated in the table for the heavy-duty ball and roller bearing rod ends corresponds to the maximum possible movement being limited by the shields on both sides.

It is important that this tilting angle is not exceeded either during installation or operation, as otherwise the shields may be damaged. For heavy-duty plain bearing rod ends a distinction is made between the tilting angles (a_1 and a_2).

If the movement is not limited by adjacent components, then angle a_1 can fully be used without affecting the rod end capacity. Tilting angle a_2 is the movement limit when connecting a forked component.

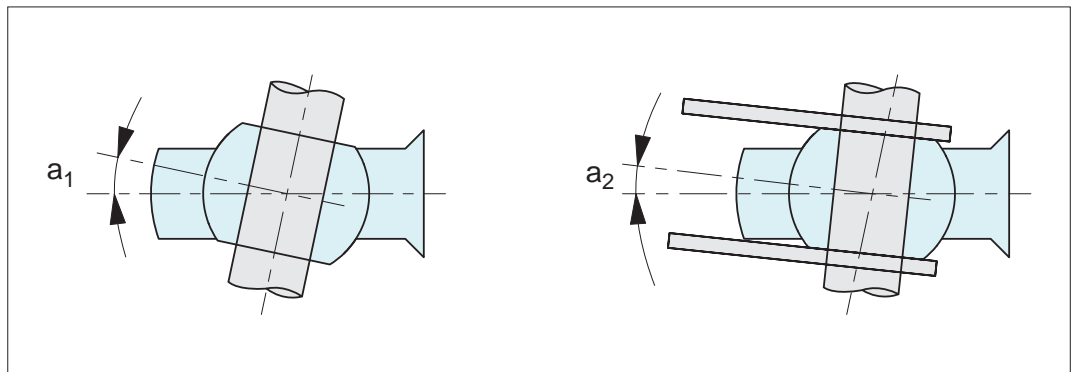

Nominal service life

The term 'nominal service life' is used for heavy-duty ball and roller bearing rod ends and represents the number of swivelling motions or rotations and/ or the number of service hours the rod end performs before showing the first signs of material fatigue on the raceway or roller bodies. In view of many factors that are difficult or impossible to assess, the service life of several apparently identical bearings differ under the same operating conditions.

For this reason, the following method for the service life determination of heavy-duty ball and roller rod ends results in a nominal service life being achieved or exceeded by at least 90% of a large quantity of identical rod ends.

Working life

The term 'working life' is used with heavy-duty plain bearing rod ends. It represents the number of swivelling motions or rotations and/ or the number of service hours the heavy duty plain bearing rod end performs before becoming unserviceable due to material fatigue, wear, increased bearing clearance or increase of the bearing friction moment.

The 'working life' is not only influenced by the size and the type of load, it is also affected by a number of factors, which are difficult to assess. A calculation of the exact service life is therefore impossible. Field-experienced standard values for the approximate 'working life' can nevertheless be determined by using the following calculation procedure which is based on numerous results from endurance test runs and values from decades of experience. The values determined by this formula are achieved, if not exceeded, by the majority of the heavy-duty rod ends.



Heavy-duty rod ends

65700, 65720, 65740, 65742,
65760, 65780, 65800

Dimensions and tolerance symbols

d_1		d_{1mp} Tolerance limit		V_{d1p}	V_{d1mp}	b_{1s} Tolerance limit		h_s, h_{1s}, h_{2s} Tolerance limit	
Over	lcl.	Upper	Lower	Max.	Max.	Upper	Lower	Upper	Lower
	6	+0,012	0	0,012	0,009	0	-0,12	+0,8	-1,2
6	10	+0,015	0	0,015	0,011	0	-0,12	+0,8	-1,2
10	18	+0,018	0	0,018	0,014	0	-0,12	+1,0	-1,7
18	30	+0,021	0	0,021	0,016	0	-0,12	+1,4	-2,1
30	50	+0,025	0	0,025	0,019	0	-0,12	+1,8	-2,7

- d_1 = nominal bore diameter of the inner ring or joint ball.
- d_{1mp} = mean bore diameter deviation in one plane, arithmetical mean of the largest and smallest bore diameter.
- V_{d1p} = bore diameter variation in one plane, difference between the largest and smallest bore diameter.
- V_{d1mp} = mean bore diameter variation, difference between the largest and smallest bore diameter of one inner ring or joint ball.
- b_{1s} = single inner ring or joint ball width deviation.
- h, h_1, h_2 = single length from inner ring or ball bore centre to shank end.
- h_s, h_{1s}, h_{2s} = single length variation of a single rod end.

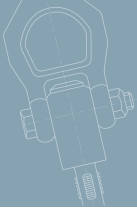

Permissible load

The maximum load is defined by the static basic load rating C_0 . If static loads are a combination of radial and axial loads, the equivalent static load will have to be calculated.

$$P_0 \leq C_0 \text{ (N)}$$

$$P_0 = \text{Static equivalent load}$$

$$\text{Self-aligning ball bearing} = P_0 = F_r + Y_0 \cdot F_a$$

$$\text{Self-aligning roller bearing} = P_0 = F_r + 5 \cdot F_a$$

- F_a = Axial load
- F_r = Radial load
- Y_0 = Axial factor, static, see individual product pages
- Y_0 = Basic static load rating (kN), see individual product pages

Nominal service life

For Rod Ends with integral self-aligning ball bearing **65740, 65742, 65760, 65820, 65840.**

Rotating

$$G_{h_{rot.}} = 10^6 \frac{\left(\frac{C}{P}\right)^3}{60 \cdot n} \text{ (h)}$$

Oscillating

$$G_{h_{osc.}} = 10^6 \frac{\left(\frac{C}{P \sqrt{\frac{\beta}{90}}}\right)^3}{60 \cdot f} \text{ (h)}$$

- P = Dynamic equivalent load (kN)
- Self-aligning ball bearing = $P = F_r + Y \cdot F_a$
- Self-aligning roller bearing = $P = F_r + 9.5 \cdot F_a$
- C = Basic dynamic load (kN), see individual product pages
- Y = axial factor, dynamic, see individual product pages
- $G_{h_{rot.}}$ = nominal service life for rotation (hours of operation)
- $G_{h_{osc.}}$ = nominal service life for rotation (hours of operation)

- β = half of swivelling angle (degree), $\beta = 90$ should be used for rotation.
- Condition: Swivelling angle $\beta < 3^\circ$. For swivelling angles $\beta < 3^\circ$ we recommend the use of heavy-duty spherical plain bearing rod ends**
- n = rotation speed (rpm)
- f = frequency of oscillation (rpm)
- h = hours

For Rod ends with integral self-aligning roller bearing **65780, 65800.**

Rotating

$$G_{h_{rot.}} = 10^6 \frac{\left(\frac{C}{P}\right)^{3,333}}{60 \cdot n} \text{ (h)}$$

Oscillating

$$G_{h_{osc.}} = 10^6 \frac{\left(\frac{C}{P \sqrt{\frac{\beta}{90}}}\right)^{3,333}}{60 \cdot f} \text{ (h)}$$

Calculation example

At the rotating side of a crank mechanism a ball or roller bearing rod end should be installed. The expected service life amounts to at least 5000 hours.

Selected: **65760.W0108** = 4,0 kN

$$G_{h_{rot.}} = 10^6 \frac{\left(\frac{C}{P}\right)^3}{60 \cdot n} \text{ (h)}$$

$$= 10^6 \frac{\left(\frac{4,0}{0,75}\right)^3}{60 \cdot 300} = 8428 \text{ h} > 5000 \text{ h} \quad \checkmark$$



The maximum permissible load is calculated by using equation 1. If static loads are a combination of radial and axial loads, the equivalent static load will have to be calculated using equation 2.

Permissible load

Permissible load

Equation 1 $P_{max} = C_0 \cdot C_2 \cdot C_4$

Equation 2 $P = F_r + F_a \leq P_{max}$

- P_{max} = Maximum permissible load (kN)
 - C_0 = Static basic load (kN), see individual product pages
 - C_2 = Temperature factor, see below
 - C_4 = Factor for type of load, see below
 - P = Equivalent dynamic load (kN)
 - F_r = Radial load
 - F_a = Axial load (kN)
- Condition: $F_a \leq 0.2 \cdot F_r$**

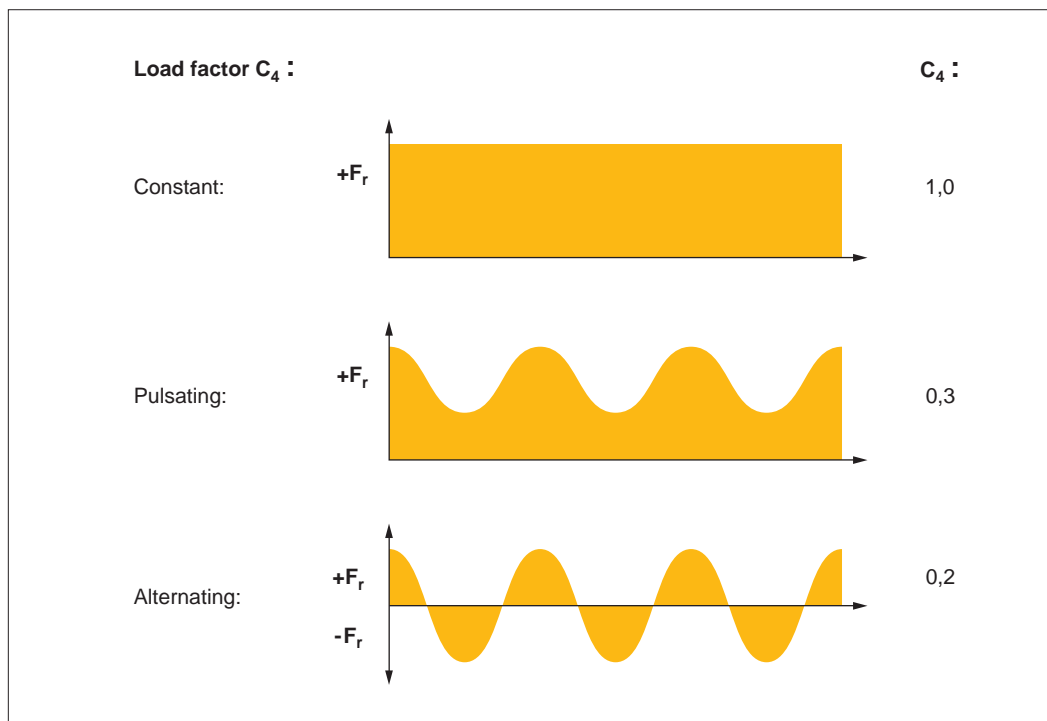

Temperature factor C_2

- Up to 60°C 1,0.
- 60°C to 80°C 0,8.
- 80°C to 100°C 0,7.
- 100°C to 120°C 0,8.

ov-W65700-AR3550-T-W65970-AR3630-T-h-rnh- Updated -31-10-2022

Specific bearing load

$$p = k \cdot \frac{P}{C}$$

Known: Permissible pv-value = 0,5 N/mm² · m/s

- P = Specific bearing load (N/mm²)
- C = Basic dynamic load rating (N), see individual product pages
- k = Specific load factor (N/mm²) for tribological pairing
k = 50 N/mm²

Mean sliding velocity

$$V_m = 5,82 \cdot 10^{-7} \cdot d_3 \cdot \beta \cdot f$$

Known: Permissible sliding velocity $v_{max} = 0,15$ m/s

- V_m = Mean sliding velocity (m/s)
- d_3 = Pivot ball diameter (mm), see individual product pages
- β = Half swivelling angle (degree), for swivelling angle > 180°
 $\beta = 90^\circ$ to be used
- f = Frequency of oscillation (rpm)

Nominal service life

$$G = C_1 \cdot C_2 \cdot C_3 \cdot \frac{3}{d_3 \cdot \beta} \cdot \frac{C}{P} \cdot 10^8$$

$$G_h = C_1 \cdot C_2 \cdot C_3 \cdot \frac{5}{d_3 \cdot \beta \cdot f} \cdot \frac{C}{P} \cdot 10^6$$

- G = Nominal service life (number of oscillations or revolutions)
- G_h = Nominal service life (hours)
- C_2 = Temperature factor, see previous pages
- C_3 = Material factor, see alignment chart on next page
- C_1 = Load direction factor
- $C_1 = 1,0$ = Single load direction

Alternating load direction at $f < 30$ rpm: $C_1 = 0,250$

Alternating load direction at $f > 30$ rpm: $C_1 = 0,125$

Alignment

To find C_3 calculate $\frac{C_2 \cdot C}{P}$ and on the chart below, read across to C_3

- C_2 = Temperature factor
- C = Basic dynamic load rating (N) see individual product pages
- P = Specific bearing load (N/mm²)

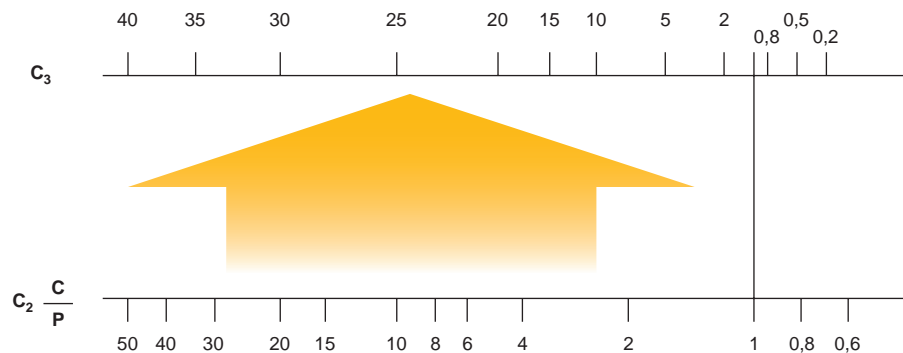



Calculation example

The rod end assembly of conveyor equipment calls for heavy-duty rod end with a service life of 7000 hours in conjunction with an alternating acting load of 5 kN. 25 swivelling moments with a swivelling angle of 20° take place per minute. The operating temperature amounts to approx. 60° C. The choice is a heavy-duty rod end **65880.W0115** with: $C = 13,4 \text{ kN}$, $d_3 = 22 \text{ mm}$.

Checking the permissible load of the rod end

$$P_{\max} = C_0 \cdot C_2 \cdot C_4$$

$$P_{\max} = 41 \cdot 0,2 \cdot 1,0 = 8,2 \text{ kN} > 5,0 \text{ kN}$$

$$C_0 = 41 \text{ kN}$$

$$C_2 = 1,0 \text{ (temperature } 60^\circ\text{C)}$$

$$C_4 = 0,2 \text{ (alternating load)}$$

Checking the permissible sliding velocity

$$V_m = 5,82 \cdot 10^{-7} \cdot d_3 \cdot \beta \cdot f = 5,82 \cdot 10^{-7} \cdot 22 \cdot 10 \cdot 25$$

$$= 0,0032 \text{ m/s} < 0,15 \text{ m/s} \quad \checkmark$$

Checking the p · V -value

$$pV = p \cdot V_m$$

$$pV = 18,66 \cdot 0,0032$$

$$= 0,06 \text{ N/mm}^2 \cdot \text{m/s} < 0,5 \text{ N/mm}^2 \cdot \text{m/s} \quad \checkmark$$

$$p = k \cdot \frac{P}{C} = 50 \cdot \frac{5000}{13400} \times 18,66 \text{ N/mm}^2$$

Nominal service life

$$G_h = C_1 \cdot C_2 \cdot C_3 \cdot \frac{5}{d_3 \cdot \beta \cdot f} \cdot \frac{C}{P} \cdot 10^6$$

$$G_h = 0,25 \cdot 1,0 \cdot 12 \cdot \frac{5}{22 \cdot 10 \cdot 25} \cdot \frac{13,4}{5,0} \cdot 10^6$$

$$= 7308 \text{ h} > 7000 \text{ h} \quad \checkmark$$

Known: $C_1 = 0,25$ (alternating load direction, $f = 25 \text{ rpm} < 30 \text{ rpm}$)

$$C_3 = C_2 \cdot \frac{C}{P} = 1,0 \cdot \frac{13,4}{5,0} = 2,68$$

See alignment chart $C_3 = 12$

$$d_3 = 22$$

$$f = 25 \text{ rpm}$$

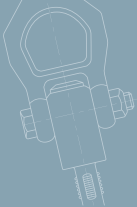

Radial static load

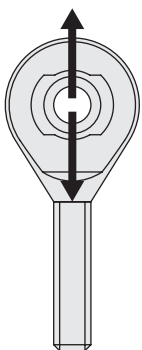

The ultimate radial static load rating is measured as the failure point when a load is increasingly applied to a pin through the rod end's bore and pulled straight up while the rod end is held in place. Note that the actual rating is determined by calculating the lowest of the following three values:

1. Raceway material comprehensive strength (R value)

$$R = E \times T \times X$$

2. Rod end head strength (H value, cartridge type construction)

$$H = \left[\left(\frac{T}{2} \sqrt{D^2 - T^2} \right) + \left(\frac{D}{2} \times \sin^{-1} \frac{T}{2} \right) - (\text{O.D. of Bearing} \times T) \right] \times X$$

Angle of $\frac{T}{2}$ expressed in radians

3. Shank strength (S value)

Male Threaded Rod End

$$S = [(\text{root diameter of thread}^2 \times .78) - (N^2 \times .78)] \times X$$

Female Threaded Rod End

$$S_2 = [(J^2 \times .78) + (\text{major diameter of thread} \times .78)] \times X$$

- E = Ball diameter
- T = Housing width
- X = Allowable stress
- D = Head diameter
- N = Diameter of drilled hole in shank of male rod end
- J = Shank diameter of female rod end

Axial static load

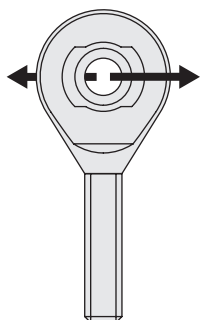

The axial static load capacity is measured as the force required to cause failure via a load parallel to the axis of the bore. Depending on the material types and construction methods, the ultimate axial load is generally 10-20% of the ultimate radial static load. The formula does not account for the bending of the shank due to a moment of force, nor the strength of the stake in cartridge-type construction.

Axial strength (A value)

$$A = .78 [(E + .176T)^2 - E^2] \times X$$

- X = Allowable Stress (see table)
- E = Ball diameter
- T = Housing width

Material	Allowable stress (PSI)
300 Series stainless steel	35,000
Low carbon steel	52,000



Heavy-Duty Rod Ends - Female

with integral spherical plain bearing

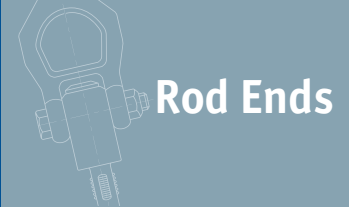

Rod Ends

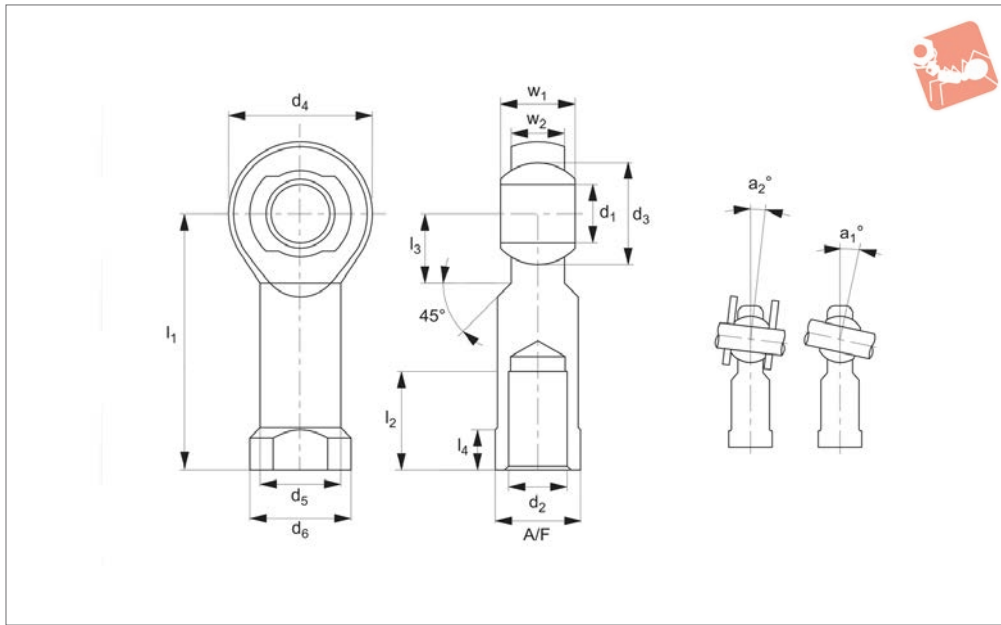

65720

ROD ENDS

Material

Rod end housing - forged steel, tempered, surface galvanized.

Joint ball - ball bearing steel, hardened and ground, polished and chromium plated.

Race - nylon/teflon/glass compound.

Technical Notes

Maintenance free, sizes according to DIN ISO 12240-4, series K, thread according to Cetop RP 103 P.

For tolerances see technical pages.

Tips

Standard thread is right hand thread.

Important Notes

* Denotes fine pitch thread.

Order No.	Thread hand	d ₁	l ₁	d ₂	d ₃	d ₄	d ₅	d ₆	l ₂	Weight g
65720.W0004	Right	5	27	M4	11.11	18	9.0	11	10	18
65720.W0005	Right	5	27	M5	11.11	18	9.0	11	10	18
65720.W0006	Right	6	30	M6	12.70	20	10.0	13	12	24
65720.W0008	Right	8	36	M8	15.87	24	12.5	16	16	45
65720.W0010	Right	10	43	M10	19.05	28	15.0	19	20	74
65720.W0011	Right	10	43	M10x1,25*	19.05	28	15.0	19	20	74
65720.W0012	Right	12	50	M12	22.22	32	17.5	22	22	109
65720.W0013	Right	12	50	M12x1,25*	22.22	32	17.5	22	22	109
65720.W0014	Right	14	57	M14	25.40	36	20.0	25	25	155
65720.W0016	Right	16	64	M16	28.57	42	22.0	27	28	233
65720.W0017	Right	16	64	M16x1,5*	28.57	42	22.0	27	28	233
65720.W0018	Right	18	71	M18x1,5*	31.75	46	25.0	31	32	310
65720.W0020	Right	20	77	M20x1,5*	34.92	50	27.5	34	33	386
65720.W0022	Right	22	84	M22x1,5*	38.10	54	30.0	38	37	520
65720.W0025	Right	25	94	M24x2*	42.85	60	33.5	42	42	705
65720.W0030	Right	30	110	M30x2*	50.80	70	40.0	50	51	1084
65720.W0031	Right	30	110	M27x2*	50.80	70	40.0	50	51	1084
65720.W0504	Left	5	27	M4	11.11	18	9.0	11	10	18
65720.W0505	Left	5	27	M5	11.11	18	9.0	11	10	18
65720.W0506	Left	6	30	M6	12.70	20	10.0	13	12	24
65720.W0508	Left	8	36	M8	15.87	24	12.5	16	16	45
65720.W0510	Left	10	43	M10	19.05	28	15.0	19	20	74
65720.W0511	Left	10	43	M10x1,25*	19.05	28	15.0	19	20	74
65720.W0512	Left	12	50	M12	22.22	32	17.5	22	22	109
65720.W0513	Left	12	50	M12x1,25*	22.22	32	17.5	22	22	109
65720.W0514	Left	14	57	M14	25.40	36	20.0	25	25	155
65720.W0516	Left	16	64	M16	28.57	42	22.0	27	28	233
65720.W0517	Left	16	64	M16x1,5*	28.57	42	22.0	27	28	233
65720.W0518	Left	18	71	M18x1,5*	31.75	46	25.0	31	32	310
65720.W0520	Left	20	77	M20x1,5*	34.92	50	27.5	34	33	386
65720.W0522	Left	22	84	M22x1,5*	38.10	54	30.0	38	37	520
65720.W0525	Left	25	94	M24x2*	42.85	60	33.5	42	42	705

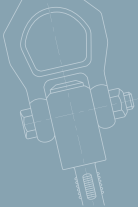

Heavy-Duty Rod Ends - Female with integral spherical plain bearing



Order No.	Thread hand	d ₁	l ₁	d ₂	d ₃	d ₄	d ₅	d ₆	l ₂	Weight g
65720.W0530	Left	30	110	M30x2*	50.80	70	40.0	50	51	1084
65720.W0531	Left	30	110	M27x2*	50.80	70	40.0	50	51	1084

ROD ENDS

Order No.	l ₃	l ₄	w ₁	w ₂	A/F	a ₁	a ₂	Dyn. load C kN max.	Static load C ₀ kN max.
65720.W0004	10	4.0	8	6.00	9	13.0	7.5	3.91	10.8
65720.W0005	10	4.0	8	6.00	9	13.0	7.5	3.91	10.8
65720.W0006	12	5.0	9	6.75	11	13.0	6.5	4.59	12.8
65720.W0008	12	5.0	12	9.00	14	14.5	7.5	6.965	19.2
65720.W0010	15	6.5	14	10.50	17	13.5	8.0	10.42	27.4
65720.W0011	15	6.5	14	10.50	17	13.5	8.0	10.42	27.4
65720.W0012	16	6.5	16	12.00	19	13.0	8.0	12.42	33.4
65720.W0013	16	6.5	16	12.00	19	13.0	8.0	12.42	33.4
65720.W0014	20	8.0	19	13.50	22	16.0	9.5	15.44	41.3
65720.W0016	22	8.0	21	15.00	22	15.5	8.5	22.41	59.6
65720.W0017	22	8.0	21	15.00	22	15.5	8.5	22.41	59.6
65720.W0018	24	10.0	23	16.50	27	15.0	9.5	26.32	69.7
65720.W0020	26	10.0	25	18.00	30	14.5	9.0	30.80	82.2
65720.W0022	26	12.0	28	20.00	32	15.5	10.0	38.23	95.60
65720.W0025	30	12.0	31	22.00	36	15.0	10.0	45.35	118.6
65720.W0030	35	15.0	37	25.00	41	17.0	10.5	55.01	145.6
65720.W0031	35	15.0	37	25.00	41	17.0	10.5	55.01	145.6
65720.W0504	10	4.0	8	6.00	9	13.0	7.5	3.91	10.8
65720.W0505	10	4.0	8	6.00	9	13.0	7.5	3.91	10.8
65720.W0506	12	5.0	9	6.75	11	13.0	6.5	4.59	12.8
65720.W0508	12	5.0	12	9.00	14	14.5	7.5	6.965	19.2
65720.W0510	15	6.5	14	10.50	17	13.5	8.0	10.42	27.4
65720.W0511	15	6.5	14	10.50	17	13.5	8.0	10.42	27.4
65720.W0512	16	6.5	16	12.00	19	13.0	8.0	12.42	33.4
65720.W0513	16	6.5	16	12.00	19	13.0	8.0	12.42	33.4
65720.W0514	20	8.0	19	13.50	22	16.0	9.5	15.44	41.3
65720.W0516	22	8.0	21	15.00	22	15.5	8.5	22.41	59.6
65720.W0517	22	8.0	21	15.00	22	15.5	8.5	22.41	59.6
65720.W0518	24	10.0	23	16.50	27	15.0	9.5	26.32	69.7
65720.W0520	26	10.0	25	18.00	30	14.5	9.0	30.80	82.2
65720.W0522	26	12.0	28	20.00	32	15.5	10.0	38.23	95.6
65720.W0525	30	12.0	31	22.00	36	15.0	10.0	45.35	118.6
65720.W0530	35	15.0	37	25.00	41	17.0	10.5	55.01	145.6
65720.W0531	35	15.0	37	25.00	41	17.0	10.5	55.01	145.6



Heavy-Duty Rod Ends - Female with integral ball bearing

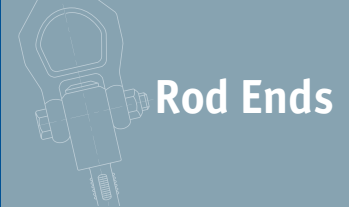

Rod Ends

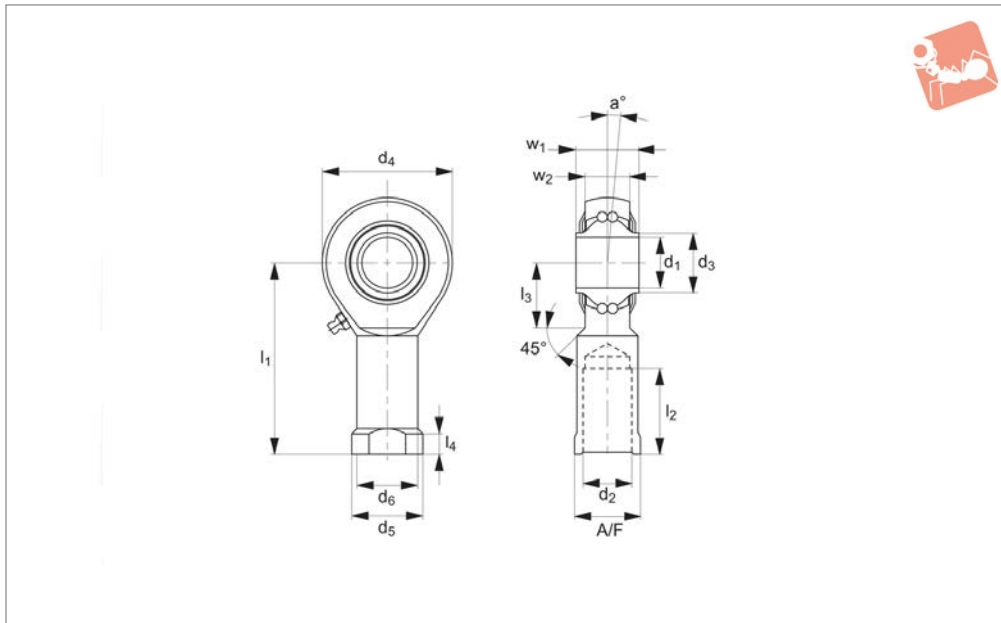

65760

ROD ENDS

Material

Rod end housing - forged steel, tempered, case hardened bearing race, ground and lapped, surface galvanized.
Inner ring - ball bearing steel, hardened, superfine ground.
Lubrication - calcium-complex-soap-

grease, temp range -20°C to +120°C.
Lubrication nipple - DIN 3405 D1/A (sizes 6 to 10) DIN 71412 H1 (sizes 12 to 30).

Technical Notes

Low maintenance. Sizes according to DIN ISO 12240-4 series K, for tolerances see

technical pages.

Tips

Standard thread is right hand thread.

Important Notes

*Denotes fine pitch thread.

Order No.	Thread hand	d ₁	l ₁	d ₂	d ₃	d ₄	d ₅	d ₆	l ₂	l ₃	l ₄	Weight g
65760.W0106	Right	6	30	M6	9.0	20	10.0	13	12	10	5.0	24
65760.W0108	Right	8	36	M8	10.5	24	12.5	16	16	12	5.0	44
65760.W0110	Right	10	43	M10	12.0	28	15.0	19	20	15	6.5	72
65760.W0112	Right	12	50	M12	14.5	32	17.5	22	22	16	6.5	107
65760.W0114	Right	14	57	M14	17.0	36	20.0	25	25	20	8.0	160
65760.W0116	Right	16	64	M16	19.0	42	22.0	27	28	22	8.0	224
65760.W0118	Right	18	71	M18X1,5*	21.5	46	25.0	31	32	24	10.0	293
65760.W0120	Right	20	77	M20X1,5*	24.5	50	27.5	34	33	26	10.0	367
65760.W0122	Right	22	84	M22X1,5*	26.0	54	30.0	38	37	26	12.0	480
65760.W0125	Right	25	94	M24X2*	29.5	64	30.0	35	42	32	10.0	572
65760.W0130	Right	30	110	M30X2*	34.5	70	40.0	50	51	35	15.0	978
65760.W0206	Left	6	30	M6	9.0	20	10.0	13	12	10	5.0	24
65760.W0208	Left	8	36	M8	10.5	24	12.5	16	16	12	5.0	44
65760.W0210	Left	10	43	M10	12.0	28	15.0	19	20	15	6.5	72
65760.W0212	Left	12	50	M12	14.5	32	17.5	22	22	16	6.5	107
65760.W0216	Left	16	64	M16	19.0	42	22.0	27	28	22	8.0	224
65760.W0214	Left	14	57	M14	17.0	36	20.0	25	25	20	8.0	160
65760.W0218	Left	18	71	M18X1,5*	21.5	46	25.0	31	32	24	10.0	293
65760.W0220	Left	20	77	M20X1,5*	24.5	50	27.5	34	33	26	10.0	367
65760.W0222	Left	22	84	M22X1,5*	26.0	54	30.0	38	37	26	12.0	480
65760.W0225	Left	25	94	M24X2*	29.5	64	30.0	35	42	32	10.0	572
65760.W0230	Left	30	110	M30X2*	34.5	70	40.0	50	51	35	15.0	978

Order No.	w ₁	w ₂	A/F	a°	Calc. factor Y	Dyn. load C kN max.	Calc. factor Y ₀	Speed rpm max.	Static load C ₀ kN max.
65760.W0106	9	6.75	11	8.0	2.09	2.8	2.19	1350	0.7
65760.W0108	12	9.00	14	8.5	1.80	4.0	1.89	1300	1.0
65760.W0110	14	10.50	17	8.0	1.90	4.5	1.81	1225	1.5
65760.W0112	16	12.00	19	7.5	1.74	5.6	1.82	1125	2.0

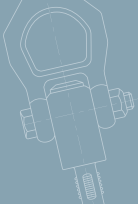

Heavy-Duty Rod Ends - Female with integral ball bearing



ROD ENDS

Order No.	w ₁	w ₂	A/F	α °	Calc. factor Y	Dyn. load C kN max.	Calc. factor Y ₀	Speed rpm max.	Static load C ₀ kN max.
65760.W0114	19	13.50	22	6.0	2.36	7.1	2.48	1025	2.9
65760.W0116	21	15.00	22	8.0	2.24	7.9	2.35	975	3.5
65760.W0118	23	16.50	27	8.5	2.21	11.0	2.31	900	5.7
65760.W0120	25	18.00	30	7.0	2.46	14.2	2.58	825	7.5
65760.W0122	28	20.00	32	8.0	2.35	14.2	2.24	725	7.5
65760.W0125	31	22.00	30	5.0	2.02	14.2	2.12	600	7.5
65760.W0130	37	25.00	41	7.5	2.24	14.2	2.35	450	7.5
65760.W0206	9	6.75	11	8.0	2.09	2.8	2.19	1350	0.7
65760.W0208	12	9.00	14	8.5	1.80	4.0	1.89	1300	1.0
65760.W0210	14	10.50	17	8.0	1.90	4.5	1.81	1225	1.5
65760.W0212	16	12.00	19	7.5	1.74	5.6	1.82	1125	2.0
65760.W0216	21	15.00	22	8.0	2.24	7.9	2.35	1025	3.5
65760.W0214	19	13.50	22	6.0	2.36	7.1	2.48	975	2.9
65760.W0218	23	16.50	27	8.5	2.21	11.0	2.31	900	5.7
65760.W0220	25	18.00	30	7.0	2.46	14.2	2.58	825	7.5
65760.W0222	28	20.00	32	8.0	2.35	14.2	2.24	725	7.5
65760.W0225	31	22.00	30	5.0	2.02	14.2	2.12	600	7.5
65760.W0230	37	25.00	41	7.5	2.24	14.2	2.35	425	7.5



Heavy-Duty Rod Ends - Female with integral roller bearing

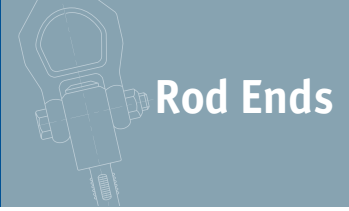

Rod Ends

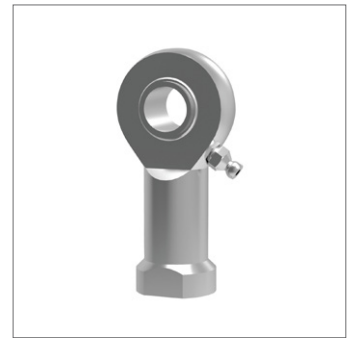
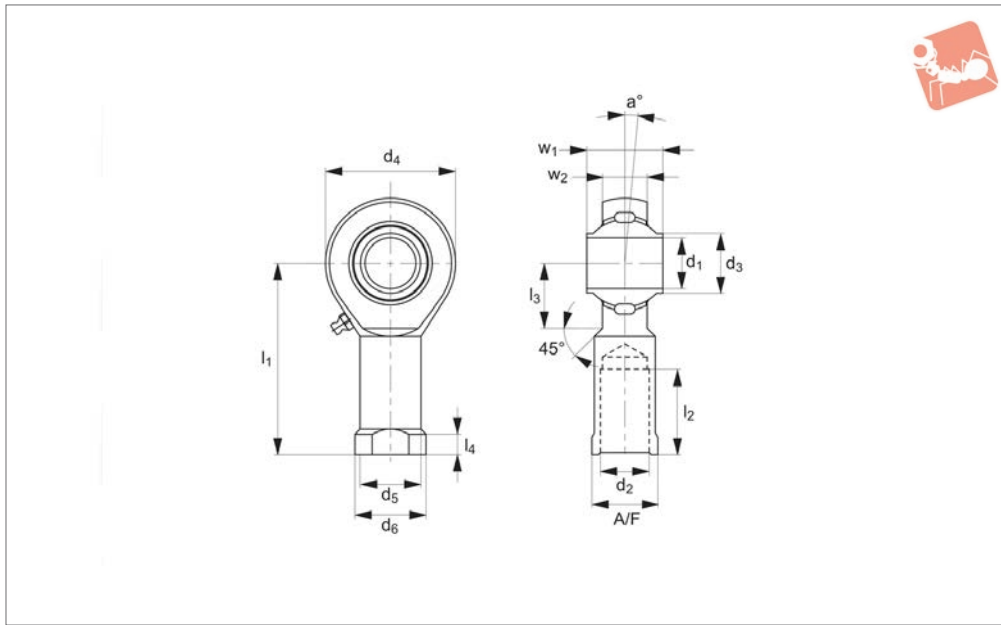

65800

ROD ENDS

Material

Rod end housing - forged steel, tempered, case hardened bearing race, ground and lapped, surface galvanized.
Inner ring - ball bearing steel, hardened, superfine ground.
Lubrication - calcium-complex-soap-

grease, temp. range -20°C to +120°C, lubrication nipple - DIN 71412 HZ.

Technical Notes

Low maintenance. Sizes according to DIN ISO 12240-4, series K, for tolerances see technical pages.

Tips

Standard thread is right hand thread.

Important Notes

*Denotes fine pitch thread.

Order No.	Thread hand	d ₁	l ₁	d ₂	d ₃	d ₄	d ₅	d ₆	l ₂	Weight g
65800.W0112	Right	12	50.0	M12	14.5	32	17.5	22	22.0	109
65800.W0116	Right	16	64.0	M16	19.0	42	22.0	27	28.0	220
65800.W0120	Right	20	77.0	M20x1,5*	24.5	50	27.5	34	33.0	361
65800.W0125	Right	25	94.0	M24x2*	29.5	64	30.0	35	42.0	565
65800.W0130	Right	30	110.0	M30x2*	34.5	70	40.0	50	51.0	1000
65800.W0212	Left	12	50.0	M12	14.5	32	17.5	22	22.0	109
65800.W0216	Left	16	64.0	M16	19.0	42	22.0	27	28.0	220
65800.W0220	Left	20	77.0	M20x1,5*	24.5	50	27.5	34	33.0	361
65800.W0225	Left	25	94.0	M24x2*	29.5	64	30.0	35	42.0	565
65800.W0230	Left	30	110.0	M30x2*	34.5	70	40.0	50	51.0	1000

Order No.	l ₃	l ₄	w ₁	w ₂	A/F	a°	Dyn. load C kN max.	Speed rpm max.	Static load C ₀ kN max.
65800.W0112	16	6.5	16	12	19	7.5	10.3	1125	6.6
65800.W0116	22	8.0	21	15	22	7.0	13.3	975	8.9
65800.W0120	26	10.0	25	18	30	7.0	17.0	825	11.7
65800.W0125	32	10.0	31	22	30	5.0	24.9	600	18.5
65800.W0130	35	15.0	37	25	41	7.5	32.5	450	24.9
65800.W0212	16	6.5	16	12	19	7.5	10.3	1125	6.6
65800.W0216	22	8.0	21	15	22	7.0	13.3	975	8.9
65800.W0220	26	10.0	25	18	30	7.0	17.0	825	11.7
65800.W0225	32	10.0	31	22	30	5.0	24.9	600	18.5
65800.W0230	35	15.0	37	25	41	7.5	32.5	450	24.9



65880

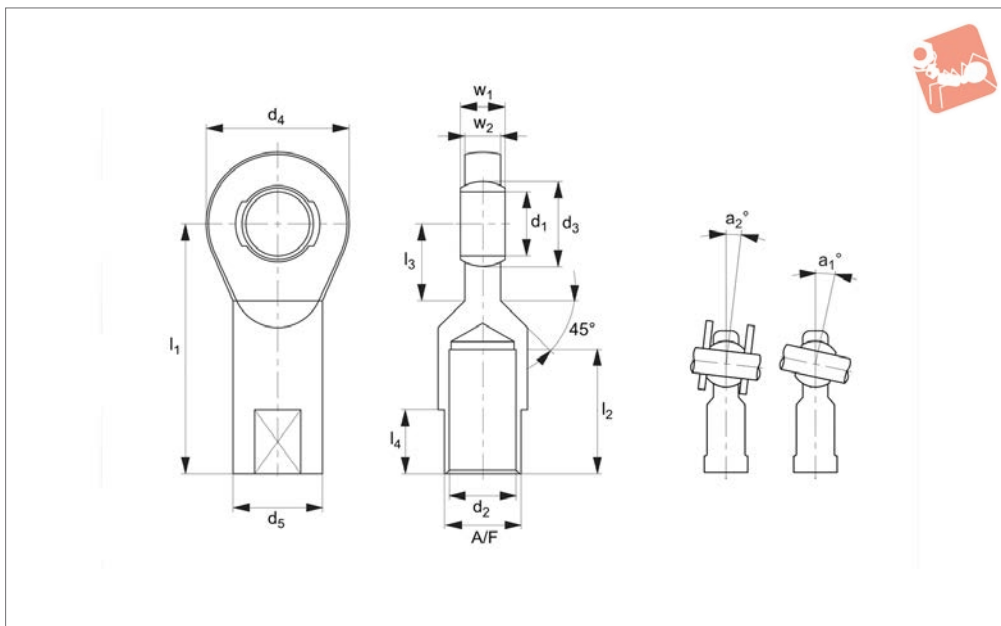

Material

Rod end housing - forged steel, tempered, surface galvanized.

Joint ball - ball bearing steel, hardened and ground, polished and chromium plated.

Race - nylon/teflon/glass compound.

Technical Notes

Female thread maintenance free adapter sizes according to DIN ISO 12240-4, series E.

For tolerances see technical pages.

Tips

Standard thread is right hand thread.

Important Notes

*Denotes fine pitch thread.

Order No.	Thread hand	d ₁	l ₁	d ₂	d ₃	d ₄	d ₅	l ₂	l ₃	Weight g
65880.W0106	Right	6	30	M6	10.0	20	10	12	11	17
65880.W0108	Right	8	36	M8	13.0	23	13	16	12	31
65880.W0110	Right	10	43	M10	16.0	28	16	20	13	54
65880.W0111	Right	10	43	M10x1,25*	16.0	28	16	20	13	54
65880.W0112	Right	12	50	M12	18.0	32	19	22	15	86
65880.W0113	Right	12	50	M12x1,25*	18.0	32	19	22	15	86
65880.W0115	Right	15	61	M14	22.0	38	22	25	18	142
65880.W0117	Right	17	67	M16	25.0	44	25	28	20	208
65880.W0120	Right	20	77	M20x1,5*	29.0	51	28	33	23	290
65880.W0125	Right	25	94	M24x2*	35.5	62	35	42	30	573
65880.W0130	Right	30	110	M30x2*	40.7	70	42	51	32	908
65880.W0135	Right	35	125	M36x3*	47.0	82	50	61	38	1230
65880.W0136	Right	35	130	M36x2*	47.0	82	50	66	38	1230
65880.W0140	Right	40	145	M42x3*	53.0	92	58	71	42	2075
65880.W0141	Right	40	142	M39x3*	53.0	92	52	66	42	1880
65880.W0145	Right	45	165	M45x3*	60.0	102	67	76	50	3085
65880.W0146	Right	45	145	M42x3*	60.0	102	58	66	50	2500
65880.W0150	Right	50	195	M52x3*	66.0	112	70	89	60	3975
65880.W0151	Right	50	160	M45x3*	66.0	112	62	69	60	3200
65880.W0160	Right	60	225	M60x4*	80.0	135	82	103	70	7300
65880.W0161	Right	60	175	M52x3*	80.0	135	71	71	70	5900
65880.W0206	Left	6	30	M6	10.0	20	10	12	11	17
65880.W0208	Left	8	36	M8	13.0	23	13	16	12	31
65880.W0210	Left	10	43	M10	16.0	28	16	20	13	54
65880.W0211	Left	10	43	M10x1,25*	16.0	28	16	20	13	54
65880.W0212	Left	12	50	M12	18.0	32	19	22	15	86
65880.W0213	Left	12	50	M12x1,25*	18.0	32	19	22	15	86
65880.W0215	Left	15	61	M14	22.0	38	22	25	18	142
65880.W0217	Left	17	67	M16	25.0	44	25	28	20	208
65880.W0220	Left	20	77	M20x1,5*	29.0	51	28	33	23	290
65880.W0225	Left	25	94	M24x2*	35.5	62	35	42	30	573
65880.W0230	Left	30	110	M30x2*	40.7	70	42	51	32	908



Heavy-Duty Rod Ends - Female

with integral spherical plain bearing



Rod Ends

Order No.	Thread hand	d ₁	l ₁	d ₂	d ₃	d ₄	d ₅	l ₂	l ₃	Weight g
65880.W0235	Left	35	125	M36x3*	47.0	82	50	61	38	1230
65880.W0236	Left	35	130	M36x2*	47.0	82	50	66	38	1230
65880.W0240	Left	40	145	M42x3*	53.0	92	58	71	42	2075
65880.W0241	Left	40	142	M39x3*	53.0	92	52	66	42	1880
65880.W0245	Left	45	165	M45x3*	60.0	102	67	76	50	3085
65880.W0246	Left	45	145	M42x3*	60.0	102	58	66	50	2500
65880.W0250	Left	50	195	M52x3*	66.0	112	70	89	60	3975
65880.W0251	Left	50	160	M45x3*	66.0	112	62	69	60	3200
65880.W0260	Left	60	225	M60x4*	80.0	135	82	103	70	7300
65880.W0261	Left	60	175	M52x3*	80.0	135	71	71	70	5900

Order No.	l ₄	w ₁	w ₂	A/F	a ₁	a ₂	Dyn. load C kN max.	Static load C ₀ kN max.
65880.W0106	-	6	4	9	13.0	6.5	2.5	10.6
65880.W0108	-	8	5	11	15.0	8.0	4.2	13.1
65880.W0110	-	9	6	14	12.0	6.0	6.4	18.8
65880.W0111	-	9	6	14	12.0	6.0	6.4	18.8
65880.W0112	-	10	7	17	10.5	5.0	9.2	28.0
65880.W0113	-	10	7	17	10.5	5.0	9.2	28.0
65880.W0115	-	12	9	19	8.5	4.5	13.4	41.0
65880.W0117	-	14	10	22	10.0	5.5	19.2	57.9
65880.W0120	-	16	12	24	9.0	4.5	25.2	76.7
65880.W0125	-	20	16	30	7.5	3.5	42.4	119.1
65880.W0130	-	22	18	36	6.0	3.0	54.0	141.8
65880.W0135	36	25	20	41	6.5	3.5	70.4	180.8
65880.W0136	41	25	20	41	6.5	3.5	70.4	180.8
65880.W0140	42	28	22	50	7.0	3.5	86.0	222.6
65880.W0141	39	28	22	46	7.0	3.5	86.0	222.6
65880.W0145	45	32	25	55	7.5	4.0	107.0	276.2
65880.W0146	42	32	25	50	7.5	4.0	107.0	276.2
65880.W0150	52	35	28	60	6.5	3.0	132.0	339.2
65880.W0151	45	35	28	55	6.5	3.0	132.0	339.2
65880.W0160	60	44	36	70	6.5	3.5	208.0	532.1
65880.W0161	52	44	36	60	6.5	3.5	208.0	532.1
65880.W0206	-	6	4	9	13.0	6.5	2.5	10.6
65880.W0208	-	8	5	11	15.0	8.0	4.2	13.1
65880.W0210	-	9	6	14	12.0	6.0	6.4	18.8
65880.W0211	-	9	6	14	12.0	6.0	6.4	18.8
65880.W0212	-	10	7	17	10.5	5.0	9.2	28.0
65880.W0213	-	10	7	17	10.5	5.0	9.2	28.0
65880.W0215	-	12	9	19	8.5	4.5	13.4	41.0
65880.W0217	-	14	10	22	10.0	5.5	19.2	57.9
65880.W0220	-	16	12	24	9.0	4.5	25.2	76.7
65880.W0225	-	20	16	30	7.5	3.5	42.4	119.1
65880.W0230	-	22	18	36	6.0	3.0	54.0	141.8
65880.W0235	36	25	20	41	6.5	3.5	70.4	180.8
65880.W0236	41	25	20	41	6.5	3.5	70.4	180.8
65880.W0240	42	28	22	50	7.0	3.5	86.0	222.6
65880.W0241	39	28	22	46	7.0	3.5	86.0	222.6
65880.W0245	45	32	25	55	7.5	4.0	107.0	276.2
65880.W0246	42	32	25	50	7.5	4.0	107.0	276.2
65880.W0250	52	35	28	60	6.5	3.0	132.0	339.2
65880.W0251	45	35	28	55	6.5	3.0	132.0	339.2
65880.W0260	60	44	36	70	6.5	3.5	208.0	532.1
65880.W0261	52	44	36	60	6.5	3.5	208.0	532.1

ROD ENDS



65742

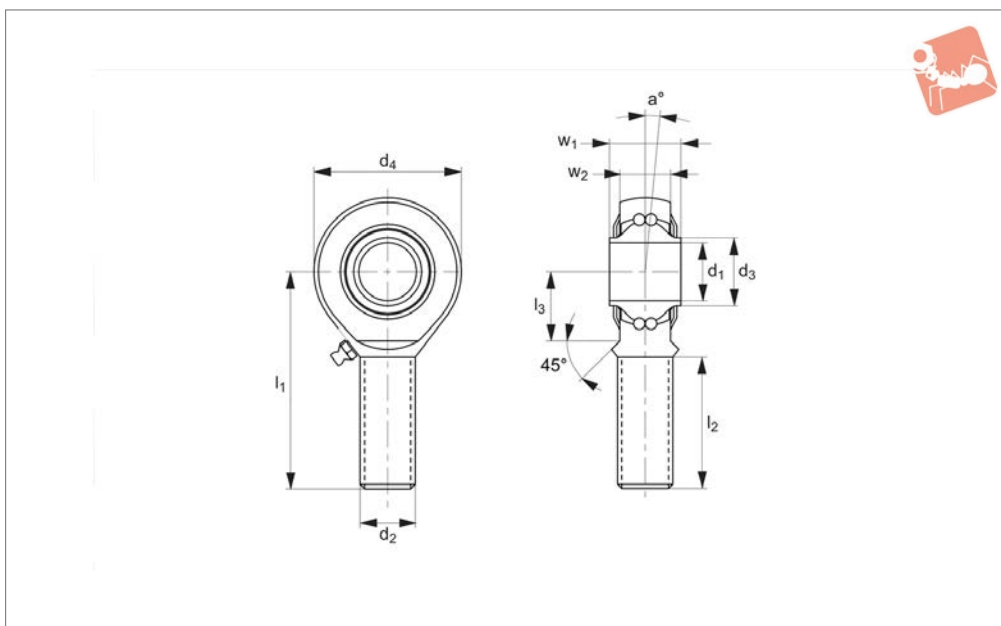

Material

Housing - stainless steel (AISI 304), forged, hardened bearing race, super-finished, rolled thread.

Inner ring - stainless steel (AISI 304), hardened, superfine finish.

Lubrication - aluminium-complex-soap-grease, temp range -45°C to +120°C.

Lubrication nipple - DIN 3405 D1/A (until size 10) DIN 71412 H1 (from size 12).

Technical Notes

Low maintenance, sizes according to DIN ISO 12240-4 series K, for tolerances see

technical pages.

Tips

Standard thread is right hand thread.

Important Notes

*Denotes fine pitch thread.

Order No.	Thread hand	d ₁	l ₁	d ₂	d ₃	l ₂	d ₄	a _°	l ₃	w ₁	Weight g
65742.W0008	Right	8	42	M8	10.5	25	24	8.5	15	12	36
65742.W0010	Right	10	48	M10	12.0	29	28	8.0	15	14	60
65742.W0012	Right	12	54	M12	14.5	33	32	7.5	19	16	87
65742.W0016	Right	16	66	M16	19.0	40	42	8.0	22	21	190
65742.W0020	Right	20	78	M20x1,5*	24.5	47	50	7.0	28	25	338
65742.W0508	Left	8	42	M8	10.5	25	24	8.5	15	12	36
65742.W0510	Left	10	48	M10	12.0	29	28	8.0	15	14	60
65742.W0512	Left	12	54	M12	14.5	33	32	7.5	19	16	87
65742.W0516	Left	16	66	M16	19.0	40	42	8.0	22	21	190
65742.W0520	Left	20	78	M20x1,5*	24.5	47	50	7.0	28	25	338

Order No.	w ₂	Calc. factor Y	Calc. factor Y ₀	Dyn. load C kN max.	Speed rpm max.	Static load C ₀ kN max.
65742.W0008	9.00	1.89	1.80	0.7	1300	2.8
65742.W0010	10.50	1.81	1.90	1.0	1225	3.1
65742.W0012	12.00	1.82	1.74	1.3	1125	3.5
65742.W0016	15.00	2.35	2.24	1.6	975	4.3
65742.W0020	18.00	2.58	2.46	2.3	825	5.4
65742.W0508	9.00	1.89	1.80	0.7	1300	2.8
65742.W0510	10.50	1.81	1.90	1.0	1225	3.1
65742.W0512	12.00	1.82	1.74	1.3	1125	3.5
65742.W0516	15.00	2.35	2.24	1.6	975	4.3
65742.W0520	18.00	2.58	2.46	2.3	825	5.4



Heavy-Duty Rod Ends - Male with integral roller bearing

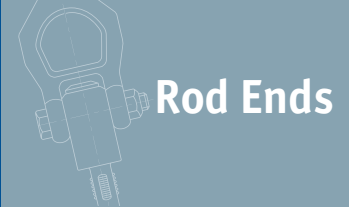

Rod Ends

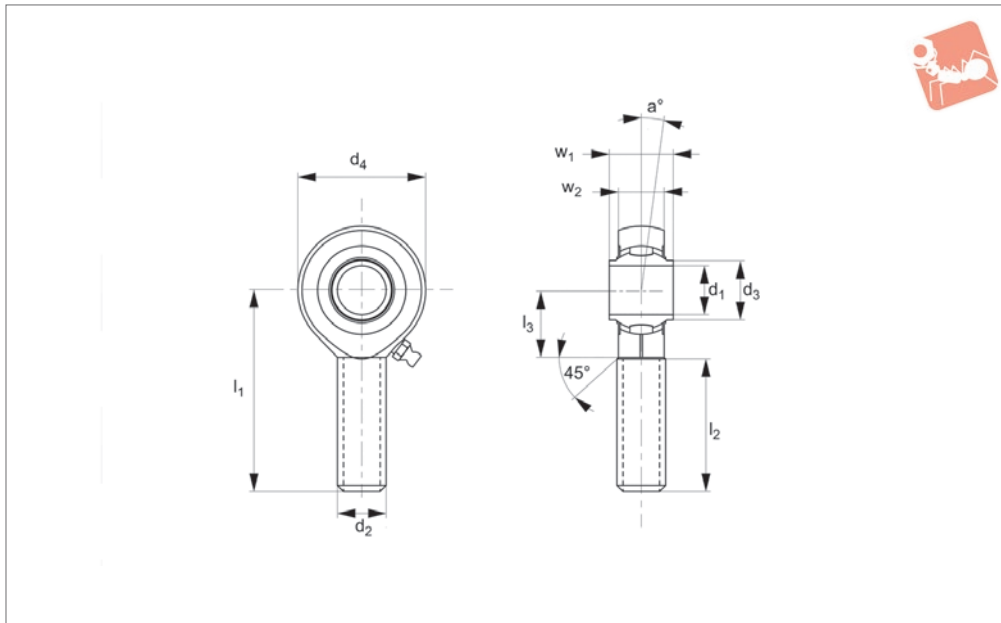

65780

ROD ENDS

Material

Rod end housing - forged steel, tempered, case hardened bearing race, ground and lapped, surface galvanized.
Inner ring - ball bearing steel, hardened, superfine ground.
Lubrication - calcium-complex-soap-

grease, temp. range -20°C to +120°C, lubrication nipple - DIN 71412 HZ.

Technical Notes

Low maintenance. Sizes according to DIN ISO 12240-4, series K, for tolerances see technical pages.

Tips

Standard thread is right hand thread.

Important Notes

*Denotes fine pitch thread.

Order No.	Thread hand	d ₁	l ₁	d ₂	d ₃	l ₂	d ₄	a	Weight g
65780.W0112	Right	12	54	M12	14.5	33	32	7.5	88
65780.W0116	Right	16	66	M16	19.0	40	42	7.0	185
65780.W0120	Right	20	78	M20x1,5*	24.5	47	50	7.0	340
65780.W0125	Right	25	94	M24x2*	29.5	57	64	5.0	596
65780.W0130	Right	30	110	M30x2*	34.5	66	70	7.5	912
65780.W0512	Left	12	54	M12	14.5	33	32	7.5	88
65780.W0516	Left	16	66	M16	19.0	40	42	7.0	185
65780.W0520	Left	20	78	M20x1,5*	24.5	47	50	7.0	340
65780.W0525	Left	25	94	M24x2*	29.5	57	64	5.0	596
65780.W0530	Left	30	110	M30x2*	34.5	66	70	7.5	912

Order No.	l ₃	w ₁	w ₂	Dyn. load C kN max.	Speed rpm max.	Static load C ₀ kN max.
65780.W0112	19	16	12	10.25	1125	6.6
65780.W0116	22	21	15	13.3	975	8.9
65780.W0120	28	25	18	17.0	825	11.7
65780.W0125	30	31	22	24.90	600	18.5
65780.W0130	35	37	25	32.5	450	24.8
65780.W0512	19	16	12	10.25	1125	6.6
65780.W0516	22	21	15	13.3	975	8.9
65780.W0520	28	25	18	17.0	825	11.7
65780.W0525	30	31	22	24.9	600	18.5
65780.W0530	35	37	25	32.5	450	24.8



65722

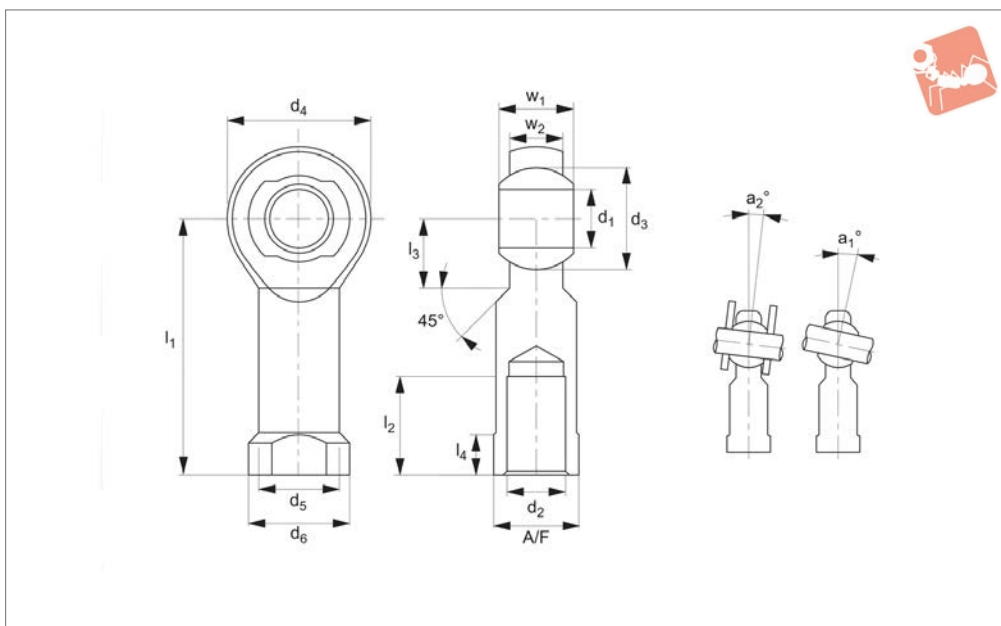

Material

Rod end housing: Stainless steel DIN 12240-4 (AISI 304).

Joint Ball: Stainless steel 1.4412, hardened and ground, surface polished.

Race: nylon/teflon/glass compound.

Technical Notes

Maintenance free, for tolerances see technical page 123, standard thread is right hand thread.

Technical page 123, standard thread is right hand thread.

Tips

A2 stainless steel provides good corrosion resistance to a wide range of atmospheric conditions and corrosive media.

It is considered resistant to potable water.

Important Notes

*Denotes fine pitch thread.

Order No.	Thread hand	d ₁	l ₁	d ₂	d ₃	d ₄	d ₅	d ₆	l ₂	Weight g
65722.W0104	Right	5	36	M4	11.11	18	9.0	11	10	18
65722.W0105	Right	5	36	M5	11.11	18	9.0	11	10	18
65722.W0106	Right	6	40	M6	12.70	20	10.0	13	12	24
65722.W0108	Right	8	48	M8	15.87	24	12.5	16	16	45
65722.W0110	Right	10	57	M10	19.05	28	15.0	19	20	74
65722.W0111	Right	10	57	M10x1,25*	19.05	28	15.0	19	20	74
65722.W0112	Right	12	66	M12	22.22	32	17.5	22	22	109
65722.W0113	Right	12	66	M12x1,25*	22.22	32	17.5	22	22	109
65722.W0114	Right	14	75	M14	25.40	36	20.0	25	25	155
65722.W0116	Right	16	85	M16	28.57	42	22.0	27	28	233
65722.W0117	Right	16	85	M16x1,5*	28.57	42	22.0	27	28	233
65722.W0118	Right	18	94	M18x1,5*	31.75	46	25.0	31	32	310
65722.W0120	Right	20	102	M20x1,5*	34.92	50	27.5	34	33	386
65722.W0122	Right	22	111	M22x1,5*	38.10	54	30.0	38	37	520
65722.W0125	Right	25	124	M24x2*	42.85	60	33.5	42	42	705
65722.W0130	Right	30	145	M30x2*	50.80	70	40.0	50	51	1084
65722.W0131	Right	30	145	M27x2*	50.80	70	40.0	50	51	1084
65722.W0504	Left	5	36	M4	11.11	18	9.0	11	10	18
65722.W0505	Left	5	36	M5	11.11	18	9.0	11	10	18
65722.W0506	Left	6	40	M6	12.70	20	10.0	13	12	24
65722.W0508	Left	8	48	M8	15.87	24	12.5	16	16	45
65722.W0510	Left	10	57	M10	19.05	28	15.0	19	20	74
65722.W0511	Left	10	57	M10x1,25*	19.05	28	15.0	19	20	74
65722.W0512	Left	12	66	M12	22.22	32	17.5	22	22	109
65722.W0513	Left	12	66	M12x1,25*	22.22	32	17.5	22	22	109
65722.W0514	Left	14	75	M14	25.40	36	20.0	25	25	155
65722.W0516	Left	16	85	M16	28.57	42	22.0	27	28	233
65722.W0517	Left	16	85	M16x1,5*	28.57	42	22.0	27	28	233
65722.W0518	Left	18	94	M18x1,5*	31.75	46	25.0	31	32	310



Stainless Heavy-Duty Rod Ends - with integral spherical plain bearing



Rod Ends

Order No.	Thread hand	d ₁	l ₁	d ₂	d ₃	d ₄	d ₅	d ₆	l ₂	Weight g
65722.W0520	Left	20	102	M20x1,5*	34.92	50	27.5	34	33	386
65722.W0522	Left	22	111	M22x1,5*	38.10	54	30.0	38	37	520
65722.W0525	Left	25	124	M24x2*	42.85	60	33.5	42	42	705
65722.W0530	Left	30	145	M30x2*	50.80	70	40.0	50	51	1084
65722.W0531	Left	30	145	M27x2*	50.80	70	40.0	50	51	1084

Order No.	l ₃	l ₄	w ₁	w ₂	A/F	a ₁	a ₂	Dyn. load C kN max.	Static load C ₀ kN max.
65722.W0104	10	4.0	8	6.00	9	13.0	7.5	3.9	7.9
65722.W0105	10	4.0	8	6.00	9	13.0	7.5	3.9	7.9
65722.W0106	12	5.0	9	6.75	11	13.0	6.5	4.6	9.4
65722.W0108	12	5.0	12	9.00	14	14.5	7.5	7.0	14.1
65722.W0110	15	6.5	14	10.50	17	13.5	8.0	10.4	20.1
65722.W0111	15	6.5	14	10.50	17	13.5	8.0	10.4	20.1
65722.W0112	16	6.5	16	12.00	19	13.0	8.0	12.4	24.5
65722.W0113	16	6.5	16	12.00	19	13.0	8.0	12.4	24.5
65722.W0114	20	8.0	19	13.50	22	16.0	9.5	15.4	30.4
65722.W0116	22	8.0	21	15.00	22	15.5	8.5	22.4	43.7
65722.W0117	22	8.0	21	15.00	22	15.5	8.5	22.4	43.7
65722.W0118	24	10.0	23	16.50	27	15.0	9.5	26.3	51.2
65722.W0120	26	10.0	25	18.00	30	14.5	9.0	30.8	60.3
65722.W0122	26	12.0	28	20.00	32	15.5	10.0	38.2	70.0
65722.W0125	30	12.0	31	22.00	36	15.0	10.0	45.4	87.0
65722.W0130	35	15.0	37	25.00	41	17.0	10.5	55.0	106.8
65722.W0131	35	15.0	37	25.00	41	17.0	10.5	55.0	106.8
65722.W0504	10	4.0	8	6.00	9	13.0	7.5	3.9	7.9
65722.W0505	10	4.0	8	6.00	9	13.0	7.5	3.9	7.9
65722.W0506	12	5.0	9	6.75	11	13.0	6.5	4.6	9.4
65722.W0508	12	5.0	12	9.00	14	14.5	7.5	7.0	14.1
65722.W0510	15	6.5	14	10.50	17	13.5	8.0	10.4	20.1
65722.W0511	15	6.5	14	10.50	17	13.5	8.0	10.4	20.1
65722.W0512	16	6.5	16	12.00	19	13.0	8.0	12.4	24.5
65722.W0513	16	6.5	16	12.00	19	13.0	8.0	12.4	24.5
65722.W0514	20	8.0	19	13.50	22	16.0	9.5	15.4	30.4
65722.W0516	22	8.0	21	15.00	22	15.5	8.5	22.4	43.7
65722.W0517	22	8.0	21	15.00	22	15.5	8.5	22.4	43.7
65722.W0518	24	10.0	23	16.50	27	15.0	9.5	26.3	51.2
65722.W0520	26	10.0	25	18.00	30	14.5	9.0	30.8	60.3
65722.W0522	26	12.0	28	20.00	32	15.5	10.0	38.2	70.0
65722.W0525	30	12.0	31	22.00	36	15.0	10.0	45.4	87.0
65722.W0530	35	15.0	37	25.00	41	17.0	10.5	55.0	106.8
65722.W0531	35	15.0	37	25.00	41	17.0	10.5	55.0	106.8

ROD ENDS



65840

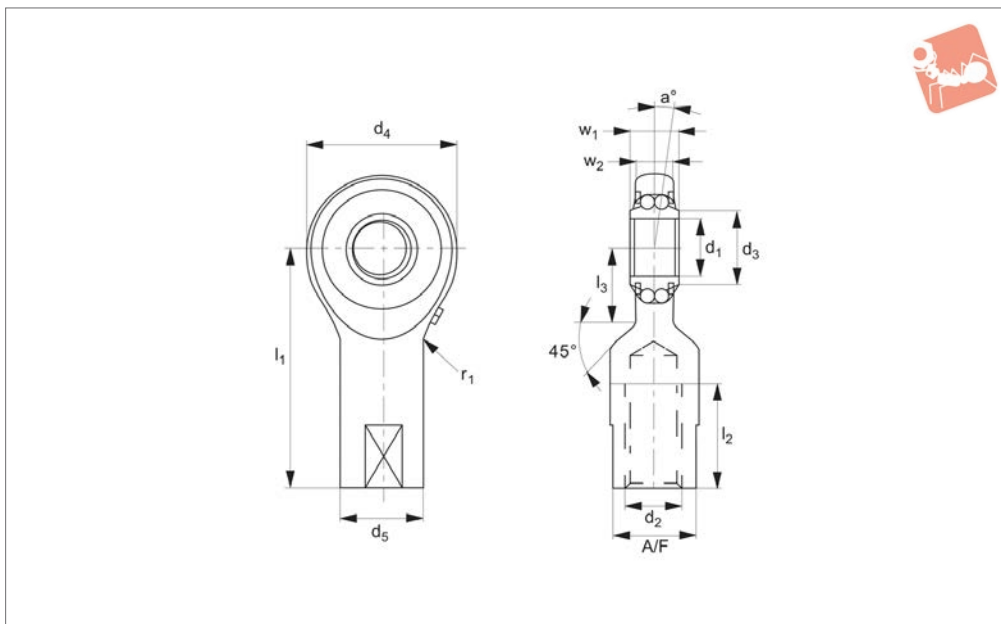

Material

Rod end housing - forged steel, tempered, case hardened bearing race, ground and lapped, surface galvanized.

Inner ring - ball bearing steel, hardened, superfine ground.

Lubrication - calcium-complex-soap-grease, temp range -20°C to +120°C, lubrication nipple - DIN 3405 D1/A.

Technical Notes

Low maintenance, for tolerances see technical pages.

Technical pages.

Tips

Standard thread is right hand thread.

Order No.	Thread hand	d ₁	l ₁	d ₂	d ₃	d ₄	d ₅	l ₂	l ₃	w ₁	w ₂	R	Weight g
65840.W0010	Right	10	38	M8	13.0	30	15	17	14.5	13.0	9	10	63
65840.W0015	Right	15	51	M12	17.5	40	19	24	20.0	16.5	12	15	140
65840.W0020	Right	20	65	M16	24.0	48	22	32	22.0	20.5	15	20	223
65840.W0510	Left	10	38	M8	13.0	30	15	17	14.5	13.0	9	10	63
65840.W0515	Left	15	51	M12	17.5	40	19	24	20.0	16.5	12	15	140
65840.W0520	Left	20	65	M16	24.0	48	22	32	22.0	20.5	15	20	223

Order No.	A/F	a°	Calc. factor Y	Dyn. load C kN max.	Calc. factor Y ₀	Speed rpm max.	Static load C ₀ kN max.
65840.W0010	13	7.0	1.90	2.6	1.81	1225	1.0
65840.W0015	17	7.0	2.30	5.0	2.41	1025	1.9
65840.W0020	19	6.5	2.34	6.1	2.45	850	3.0
65840.W0510	13	7.0	1.90	2.6	1.81	1225	1.0
65840.W0515	17	7.0	2.30	5.0	2.41	1025	1.9
65840.W0520	19	6.5	2.34	6.1	2.45	850	3.0

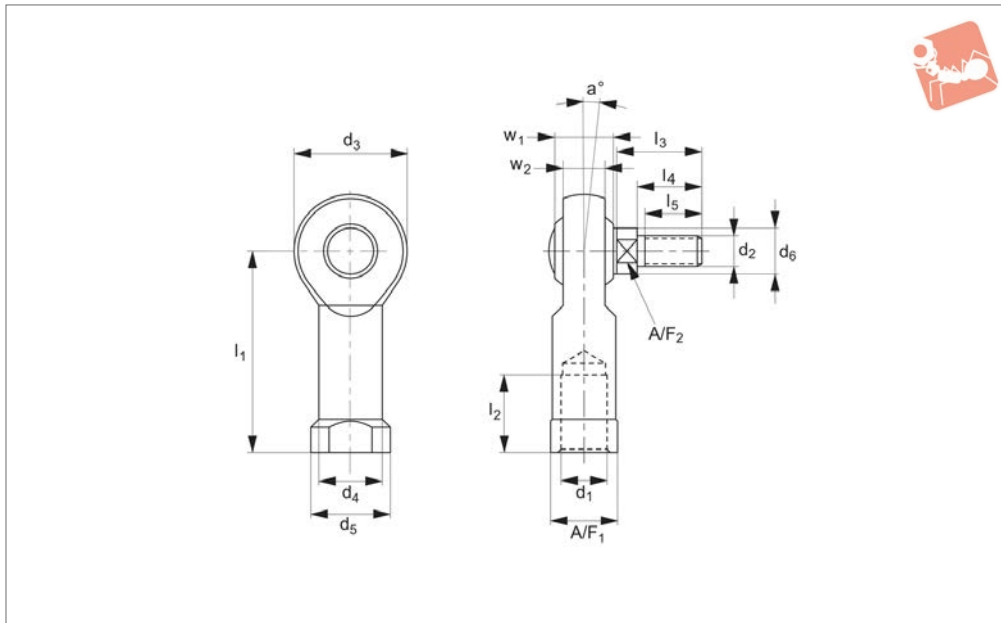
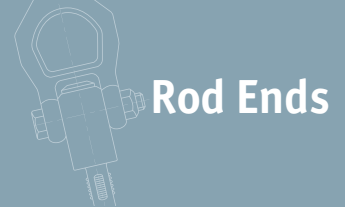

65990

ROD ENDS

Material

Body: surface zinc plated
 Race: steel/ bronze - PTFE composite.
 Inner ring: bearing steel, hardened ground and spherical surface chromium plates.
 Outer ring: brass body pressed around,

outer race lined with bronze - PTFE composite.

Technical Notes

Maintenance free. Sizes according to DIN ISO 12240-4 series K.

Tips

Standard thread is right hand thread.
 Rod end studs are all right hand threads.

Important Notes

*Denotes fine pitch threads.

Order No.	Thread hand	d ₁	d ₂	l ₁	w ₁	d ₃	d ₄	d ₅	d ₆	l ₂	Weight g
65990.W0106	Right	M6	M6	30	9	20	10.0	13	9.0	12	22
65990.W0108	Right	M8	M8	36	12	24	12.5	16	10.5	16	47
65990.W0110	Right	M10	M10	43	14	28	15.0	19	13.0	20	77
65990.W0111	Right	M10 x 1,25*	M10	43	14	28	15.0	19	13.0	20	77
65990.W0112	Right	M12	M12	50	16	32	17.5	22	15.0	22	100
65990.W0113	Right	M12 x 1,25*	M12	50	16	32	17.5	22	15.0	22	100
65990.W0114	Right	M14	M14	57	19	36	20.0	25	17.0	25	160
65990.W0115	Right	M14 x 1,5*	M14	57	19	36	20.0	25	17.0	25	160
65990.W0116	Right	M16	M16	64	21	42	22.0	27	19.0	28	220
65990.W0117	Right	M16 x 1,5*	M16	64	21	42	22.0	27	19.0	28	220
65990.W0506	Left	M6	M6	30	9	20	10.0	13	9.0	12	22
65990.W0508	Left	M8	M8	36	12	24	12.5	16	10.5	16	47
65990.W0510	Left	M10	M10	43	14	28	15.0	19	13.0	20	77
65990.W0511	Left	M10 x 1,25*	M10	43	14	28	15.0	19	13.0	20	77
65990.W0512	Left	M12	M12	50	16	32	17.5	22	15.0	22	100
65990.W0513	Left	M12 x 1,25*	M12	50	16	32	17.5	22	15.0	22	100
65990.W0514	Left	M14	M14	57	19	36	20.0	25	17.0	25	160
65990.W0515	Left	M14 x 1,50*	M14	57	19	36	20.0	25	17.0	25	160
65990.W0516	Left	M16	M16	64	21	42	22.0	27	19.0	28	220
65990.W0517	Left	M16 x 1,50*	M16	64	21	42	22.0	27	19.0	28	220

Order No.	l ₃	l ₄	l ₅	w ₂	A/F ₁	A/F ₂	a°	Static load C ₀ kN max.
65990.W0106	18.5	13	10	6.75	11	8	13	7.7
65990.W0108	23.5	17	13	9.00	14	8	14	12.9
65990.W0110	28.0	21	17	10.50	17	12	13	18.0
65990.W0111	28.0	21	17	10.50	17	12	13	18.0
65990.W0112	32.5	25	20	12.00	19	14	13	24.0
65990.W0113	32.5	25	20	12.00	19	14	13	24.0
65990.W0114	37.5	29	22	13.50	22	14	16	31.0
65990.W0115	37.5	29	22	13.50	22	14	16	31.0

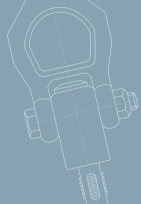

Order No.	l_3	l_4	l_5	w_2	A/F_1	A/F_2	α °	Static load C_0 kN max.
65990.W0116	42.5	33	24	15.00	22	17	15	39.0
65990.W0117	42.5	33	24	15.00	22	17	15	39.0
65990.W0506	18.5	13	10	6.75	11	8	13	7.7
65990.W0508	23.5	17	13	9.00	14	8	14	12.9
65990.W0510	28.0	21	17	10.50	17	12	13	18.0
65990.W0511	28.0	21	17	10.50	17	12	13	18.0
65990.W0512	32.5	25	20	12.00	19	14	13	24.0
65990.W0513	32.5	25	20	12.00	19	14	13	24.0
65990.W0514	37.5	29	22	13.50	22	14	16	31.0
65990.W0515	37.5	29	22	13.50	22	14	16	31.0
65990.W0516	42.5	33	24	15.00	22	17	15	39.0
65990.W0517	42.5	33	24	15.00	22	17	15	39.0

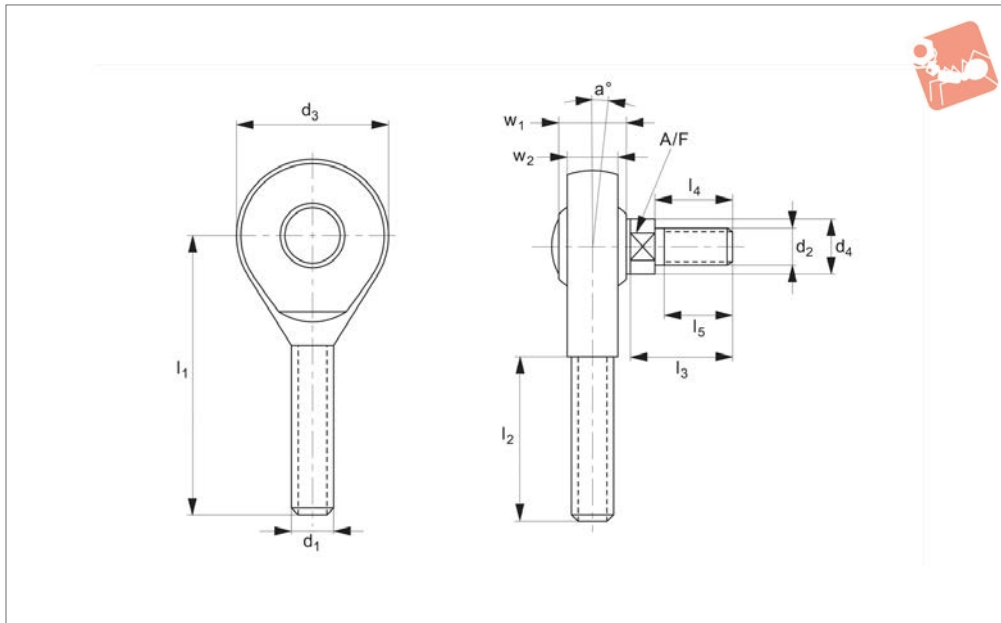
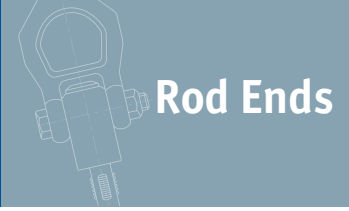

65992

ROD ENDS

Material

Body: surface zinc plated.
 Race: steel/ bronze - PTFE composite.
 Inner ring: bearing steel, hardened ground and spherical surface chromium plates.
 Outer ring: brass body pressed around,

outer race lined with bronze - PTFE composite.

Technical Notes

Maintenance free, sizes according to DIN ISO 12230-4 series K.

Tips

Standard thread is right hand thread.
 Rod end studs are all right hand threads.

Order No.	Thread hand	d ₁	d ₂	l ₁	w ₁	d ₃	d ₄	l ₂	l ₃	Weight g
65992.W0106	Right	M6	M6	36	9	20	9.0	21	18.5	20
65992.W0108	Right	M8	M8	42	12	24	10.5	25	23.5	38
65992.W0110	Right	M10	M10	48	14	28	13.0	28	28.5	55
65992.W0112	Right	M12	M12	54	16	32	15.0	32	32.5	85
65992.W0114	Right	M14	M14	60	19	36	17.0	36	37.5	140
65992.W0116	Right	M16	M16	66	21	42	19.0	37	42.5	210
65992.W0506	Left	M6	M6	36	9	20	9.0	21	18.5	20
65992.W0508	Left	M8	M8	42	12	24	10.5	25	23.5	38
65992.W0510	Left	M10	M10	48	14	28	13.0	28	28.5	55
65992.W0512	Left	M12	M12	54	16	32	15.0	32	32.5	85
65992.W0514	Left	M14	M14	60	19	36	17.0	36	37.5	140
65992.W0516	Left	M16	M16	66	21	42	19.0	37	42.5	210

Order No.	l ₄	l ₅	w ₂	A/F	a°	Static load C ₀ kN max.
65992.W0106	13	10	6.75	8	13	7.7
65992.W0108	17	13	9.00	8	14	12.9
65992.W0110	21	17	10.50	12	13	18.0
65992.W0112	25	20	12.00	14	13	24.0
65992.W0114	29	22	13.50	14	16	31.0
65992.W0116	33	24	15.00	17	15	39.0
65992.W0506	13	10	6.75	8	13	7.7
65992.W0508	17	13	9.00	8	14	12.9
65992.W0510	21	17	10.50	12	13	18.0
65992.W0512	25	20	12.00	14	13	24.0
65992.W0514	29	22	13.50	14	16	31.0
65992.W0516	33	24	15.00	17	15	39.0



65994

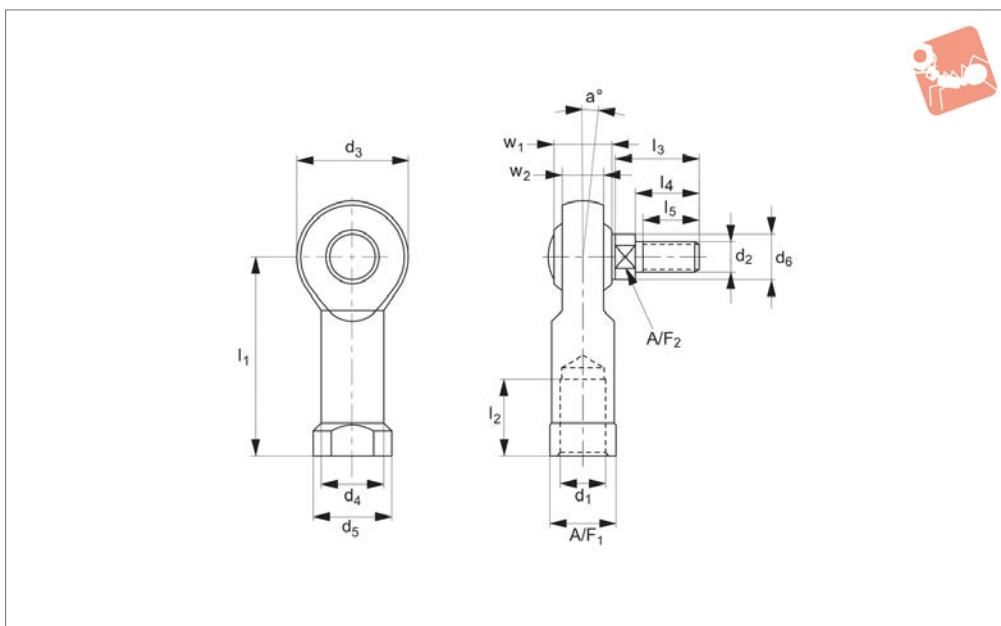

Material

Body: stainless steel (AISI 304)
 Race: steel/ bronze - PTFE composite.
 Inner ring: stainless steel, hardened and ground (AISI 304).
 Outer ring: brass body pressed around, outer race lined with bronze - PTFE compo-

site.
 Joint ball: stainless steel (AISI 440C)

Technical Notes

Maintenance free. Sizes according to DIN ISO 12740-4, series K

Tips

Standard thread is right hand thread.
 Rod end studs are all right hand threads.

Important Notes

*denotes fine pitch threads.

Order No.	Thread hand	d ₁	d ₂	l ₁	w ₁	d ₃	d ₄	d ₅	d ₆	l ₂	Weight g
65994.W0106	Right	M6	M6	30	9	20	10.0	13	9.0	12	22
65994.W0108	Right	M8	M8	36	12	24	12.5	16	10.5	16	47
65994.W0110	Right	M10	M10	43	14	28	15.0	19	13.0	20	77
65994.W0111	Right	M10 x 1,25*	M10	43	14	28	15.0	19	13.0	20	100
65994.W0112	Right	M12	M12	50	16	32	17.5	22	15.0	22	100
65994.W0113	Right	M12 x 1,25*	M12	50	16	32	17.5	22	15.0	22	100
65994.W0114	Right	M14	M14	57	19	36	20.0	25	17.0	25	160
65994.W0115	Right	M14 x 1,5*	M14	57	19	36	20.0	25	17.0	25	160
65994.W0116	Right	M16	M16	64	21	42	22.0	27	19.0	28	220
65994.W0117	Right	M16 x 1,5*	M16	64	21	42	22.0	27	19.0	28	220
65994.W0506	Left	M6	M6	30	9	20	10.0	13	9.0	12	22
65994.W0508	Left	M8	M8	36	12	24	12.5	16	10.5	16	47
65994.W0510	Left	M10	M10	43	14	28	15.0	19	13.0	20	77
65994.W0511	Left	M10 x 1,25*	M10	43	14	28	15.0	19	13.0	20	100
65994.W0512	Left	M12	M12	50	16	32	17.5	22	15.0	22	100
65994.W0513	Left	M12 x 1,25*	M12	50	16	32	17.5	22	15.0	22	100
65994.W0514	Left	M14	M14	57	19	36	20.0	25	17.0	25	160
65994.W0515	Left	M14 x 1,50*	M14	57	19	36	20.0	25	17.0	25	160
65994.W0516	Left	M16	M16	64	21	42	22.0	27	19.0	28	220
65994.W0517	Left	M16 x 1,50*	M16	64	21	42	22.0	27	19.0	28	220

Order No.	l ₃	l ₄	l ₅	w ₂	A/F ₁	A/F ₂	a°	Static load C ₀ kN max.
65994.W0106	18.5	13	10	6.75	11	8	13	7.7
65994.W0108	23.5	17	13	9.00	14	8	14	12.9
65994.W0110	28.0	21	17	10.50	17	12	13	18.0
65994.W0111	28.0	21	17	10.50	17	12	13	18.0
65994.W0112	32.5	25	20	12.00	19	14	13	24.0
65994.W0113	32.5	25	20	12.00	19	14	13	24.0



Stainless Rod End with Stud Female



Rod Ends

Order No.	l_3	l_4	l_5	w_2	A/F_1	A/F_2	α	Static load C_0 kN max.
65994.W0114	37.5	29	22	13.50	22	14	16	31.0
65994.W0115	37.5	29	22	13.50	22	14	16	31.0
65994.W0116	42.5	33	24	15.00	22	17	15	39.0
65994.W0117	42.5	33	24	15.00	22	17	15	39.0
65994.W0506	18.5	13	10	6.75	11	8	13	7.7
65994.W0508	23.5	17	13	9.00	14	8	14	12.9
65994.W0510	28.0	21	17	10.50	17	12	13	18.0
65994.W0511	28.0	21	17	10.50	17	12	13	18.0
65994.W0512	32.5	25	20	12.00	19	14	13	24.0
65994.W0513	32.5	25	20	12.00	19	14	13	24.0
65994.W0514	37.5	29	22	13.50	22	14	16	31.0
65994.W0515	37.5	29	22	13.50	22	14	16	31.0
65994.W0516	42.5	33	24	15.00	22	17	15	39.0
65994.W0517	42.5	33	24	15.00	22	17	15	39.0

ROD ENDS



65996

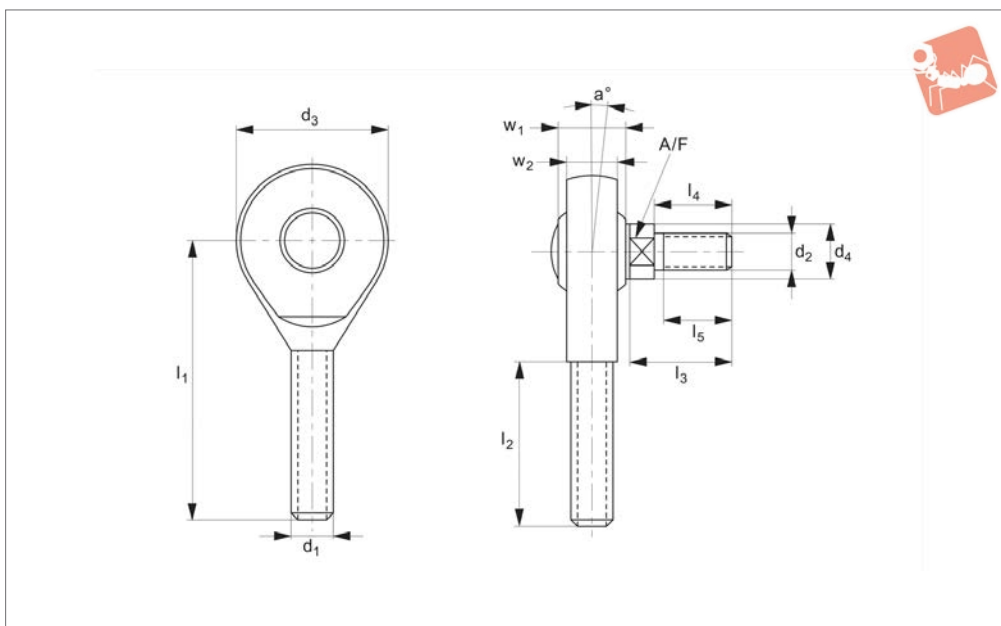

Material

Body: stainless steel (AISI 304)
 Race: steel/ bronze - PTFE composite.
 Inner ring: stainless steel, hardened and ground (AISI 304)
 Outer ring: brass body pressed around,

outer race lined with bronze - PTFE composite.

Joint ball: stainless steel (AISI 440C)

Technical Notes

Maintenance free, sizes according to DIN

ISO 12240-4 series K.

Tips

Standard thread is right hand thread.
 Rod end studs are all right hand threads.

Order No.	Thread hand	d ₁	d ₂	l ₁	w ₁	d ₃	d ₄	Weight g
65996.W0106	Right	M6	M6	36	9	20	9.0	20
65996.W0108	Right	M8	M8	42	12	24	10.5	38
65996.W0110	Right	M10	M10	48	14	28	13.0	55
65996.W0112	Right	M12	M12	54	16	32	15.0	85
65996.W0116	Right	M16	M16	66	21	42	19.0	210
65996.W0506	Left	M6	M6	36	9	20	9.0	20
65996.W0508	Left	M8	M8	42	12	24	10.5	38
65996.W0510	Left	M10	M10	48	14	28	13.0	55
65996.W0512	Left	M12	M12	54	16	32	15.0	85
65996.W0516	Left	M16	M16	66	21	42	19.0	210

Order No.	l ₂	l ₃	l ₄	l ₅	w ₂	A/F	a°	Static load C ₀ kN max.
65996.W0106	21	18.5	13	10	6.75	8	13	7.7
65996.W0108	25	23.5	17	13	9.00	8	14	12.9
65996.W0110	28	28.5	21	17	10.50	12	13	18.0
65996.W0112	32	32.5	25	20	12.00	14	13	24.0
65996.W0116	37	42.5	33	24	15.00	17	15	39.0
65996.W0506	21	18.5	13	10	6.75	8	13	7.7
65996.W0508	25	23.5	17	13	9.00	8	14	12.9
65996.W0510	28	28.5	21	17	10.50	12	13	18.0
65996.W0512	32	32.5	25	20	12.00	14	13	24.0
65996.W0516	37	42.5	33	24	15.00	17	15	39.0

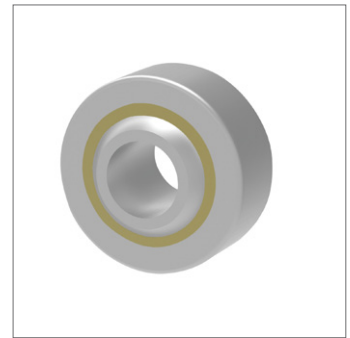
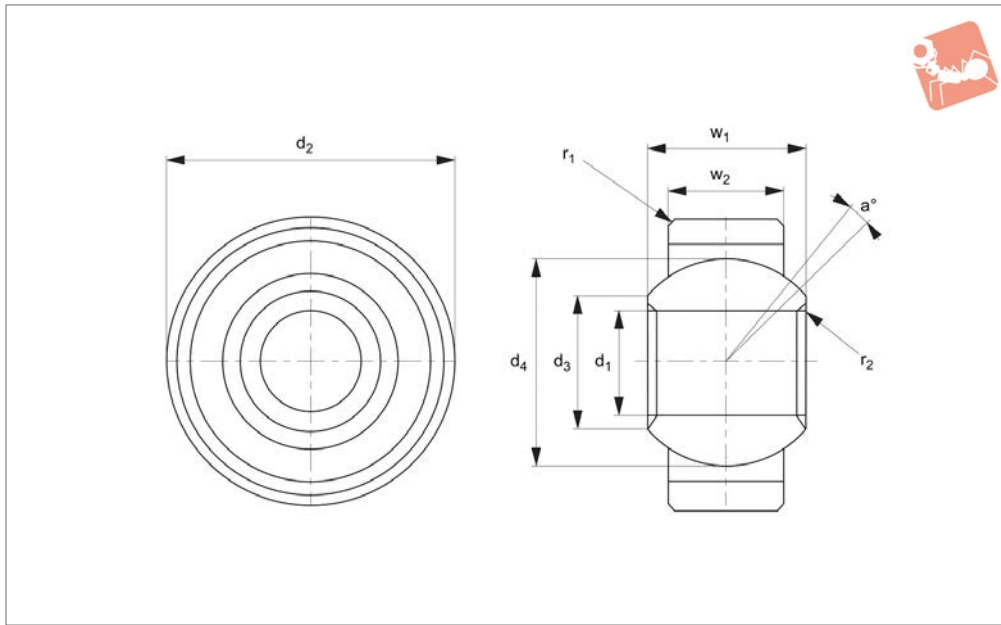

65974

ROD ENDS

Material

Housing: undercut steel 11SMnPb30K (1.0718) turned silver zinc plated.
Ball: ball bearing steel 100Cr6 hardened, surface condition polished.

Race: teflon.

Technical Notes
To DIN 12240-1

Tips

For stainless steel version see R3641

Order No.	a °	d ₁ tol. H7	d ₂	d ₃	d ₄	r ₁	r ₂	w ₁	w ₂	Static load C ₀ kN max.	Weight g
65974.W0005	13	5	16	7.7	11.10	0.3	1.2	8	6	17	9
65974.W0006	13	6	18	8.9	12.70	0.3	1.2	9	6.75	22	13
65974.W0008	13	8	22	10.3	15.88	0.3	1.2	12	9	36	24
65974.W0010	13	10	26	12.9	19.05	0.3	1.2	14	10.5	50	40
65974.W0012	13	12	30	15.4	22.23	0.4	1.2	16	12	67	80
65974.W0016	15	16	38	19.3	28.58	0.4	1.5	21	15	107	130

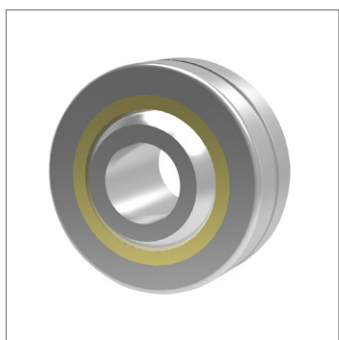

65976

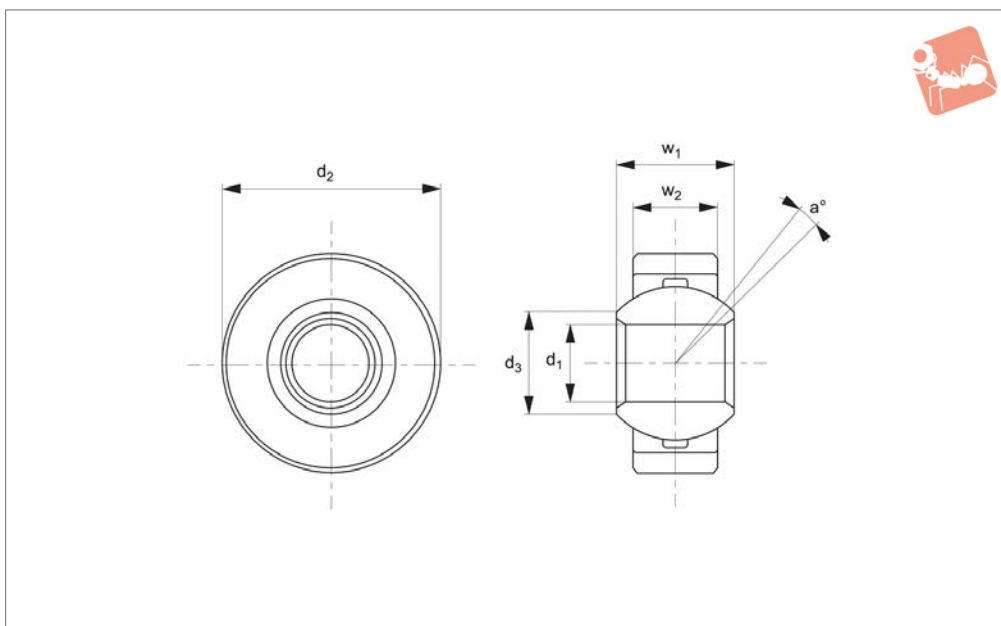

Material

Housing: stainless steel (1.4305) turned.
 Bearing shell: special brass CuSn8 surface coated with a PTFE foil.
 Ball: ball bearing steel 100Cr6 hardened, surface condition polished, hard chrome plated.
 Upon request: stainless steel (1.4034) hardened, surface condition polished.

Stainless steel (1.4401) not hardened, surface condition polished.

Technical Notes

Suitable for low speeds and high dynamic loads.

Maintenance free, series K similar to DIN 12240-1 (DIN 648)

Important Notes

Working range -50°C to +200°C
 Recommended shaft tolerance: g6

External diameter of pivoting bearing: h6

Recommended housing tolerance: J7

Order No.	a°	d ₁ tol. H7	d ₂	d ₃	w ₁	w ₂	Admissible rpm min.	Static load C ₀ kN max.	Weight g
65976.W0005	13	5	16	7.7	8	6	600	12.5	8
65976.W0006	13	6	18	8.9	9	6.75	530	15.5	12
65976.W0008	14	8	22	10.4	12	9	420	27.8	23
65976.W0010	13	10	26	12.9	14	10.5	350	39	38
65976.W0012	13	12	30	15.4	16	12	300	53.5	58
65976.W0016	15	16	38	19.3	21	15	230	88	115



Lock Nuts Coarse Thread

A2 stainless

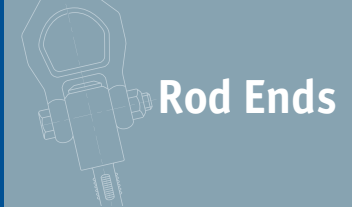

Rod Ends

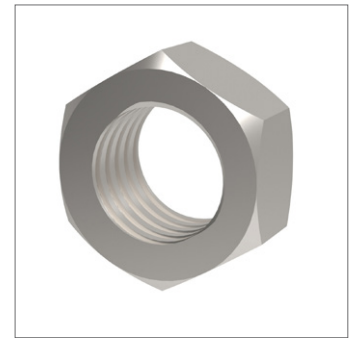
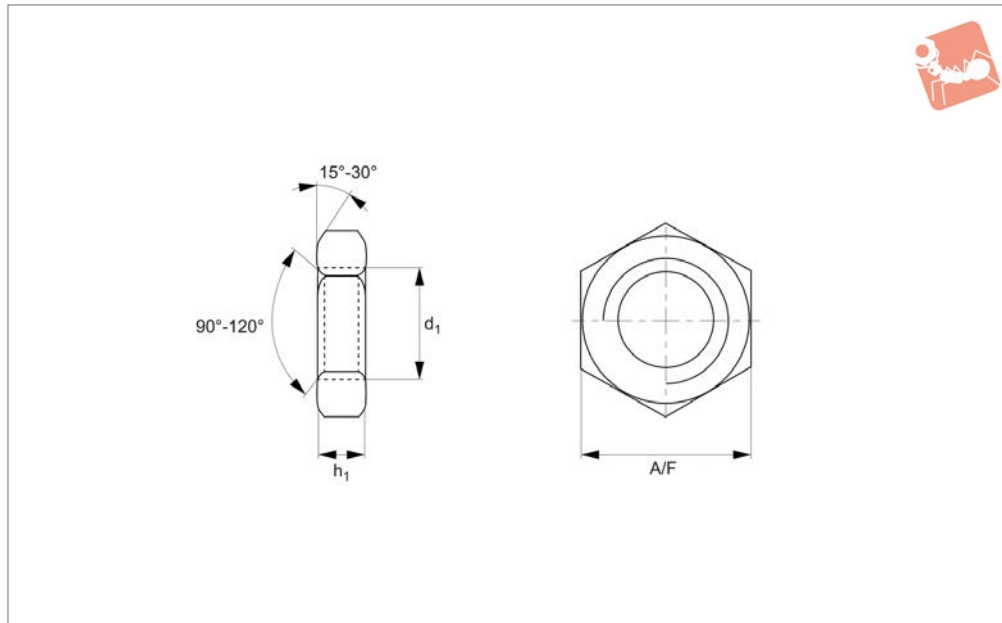

65690.A2

ROD ENDS

Material

Stainless steel (A2).

Technical Notes

To DIN 439. Standard metric coarse pitch threads.

Order No.	d ₁	h ₁	A/F	Material
65690.016-A2	M1,6	0.75	3.2	A2 s/s
65690.017-A2	M1,7	0.75	3.5	A2 s/s
65690.020-A2	M 2	0.95	4	A2 s/s
65690.023-A2	M2,3	0.95	4.5	A2 s/s
65690.025-A2	M2,5	1.35	5	A2 s/s
65690.026-A2	M2,6	1.35	5	A2 s/s
65690.030-A2	M 3	1.55	5.5	A2 s/s
65690.040-A2	M 4	1.95	7	A2 s/s
65690.050-A2	M 5	2.45	8	A2 s/s
65690.060-A2	M 6	2.9	10	A2 s/s
65690.080-A2	M 8	3.7	13	A2 s/s
65690.100-A2	M10	4.7	17	A2 s/s
65690.120-A2	M12	5.7	19	A2 s/s
65690.140-A2	M14	6.42	22	A2 s/s
65690.160-A2	M16	7.42	24	A2 s/s
65690.180-A2	M18	8.42	27	A2 s/s
65690.200-A2	M20	9.1	30	A2 s/s
65690.220-A2	M22	9.9	34	A2 s/s
65690.240-A2	M24	10.9	36	A2 s/s
65690.270-A2	M27	12.4	41	A2 s/s
65690.300-A2	M30	13.9	46	A2 s/s
65690.330-A2	M33	15.4	50	A2 s/s
65690.360-A2	M36	16.9	55	A2 s/s
65690.420-A2	M42	19.7	65	A2 s/s
65690.480-A2	M48	22.7	75	A2 s/s

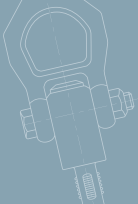

65690.A4

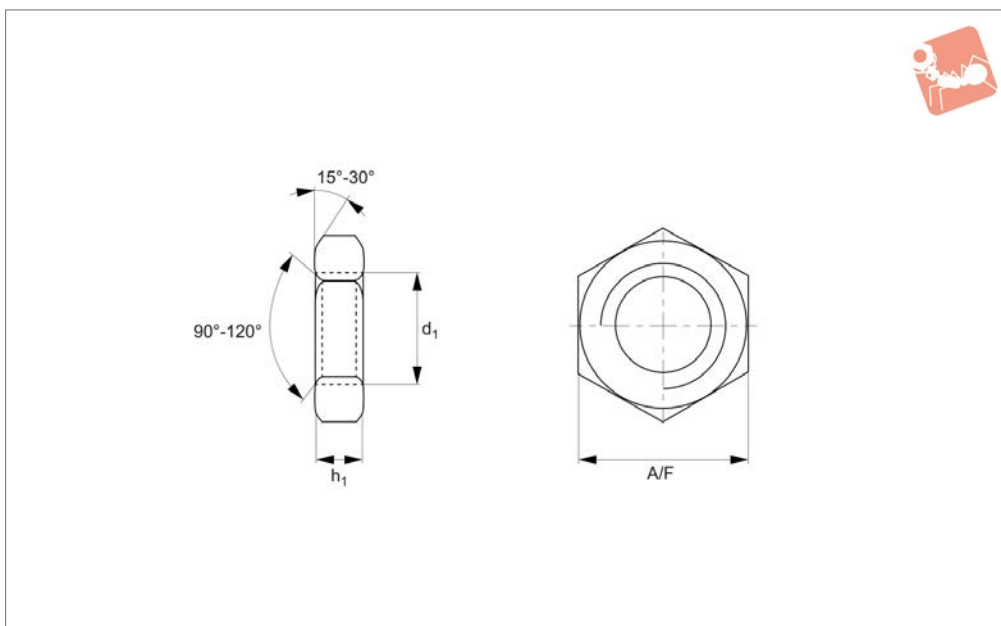

Material

Stainless steel (A4).

threads.

For fine thread lock nuts see P0306.

Technical Notes

To DIN 439. Standard metric coarse pitch

Order No.	d ₁	h ₁	A/F	Material
65690.016-A4	M1,6	0.75	3.2	A4 s/s
65690.017-A4	M1,7	0.75	3.5	A4 s/s
65690.020-A4	M 2	0.95	4	A4 s/s
65690.023-A4	M2,3	0.95	4.5	A4 s/s
65690.025-A4	M2,5	1.35	5	A4 s/s
65690.026-A4	M2,6	1.35	5	A4 s/s
65690.030-A4	M 3	1.55	5.5	A4 s/s
65690.040-A4	M 4	1.95	7	A4 s/s
65690.050-A4	M 5	2.45	8	A4 s/s
65690.060-A4	M 6	2.9	10	A4 s/s
65690.080-A4	M 8	3.7	13	A4 s/s
65690.100-A4	M10	4.7	17	A4 s/s
65690.120-A4	M12	5.7	19	A4 s/s
65690.140-A4	M14	6.42	22	A4 s/s
65690.160-A4	M16	7.42	24	A4 s/s
65690.180-A4	M18	8.42	27	A4 s/s
65690.200-A4	M20	9.1	30	A4 s/s
65690.220-A4	M22	9.9	34	A4 s/s
65690.240-A4	M24	10.9	36	A4 s/s
65690.270-A4	M27	12.4	41	A4 s/s
65690.300-A4	M30	13.9	46	A4 s/s
65690.330-A4	M33	15.4	50	A4 s/s
65690.360-A4	M36	16.9	55	A4 s/s
65690.420-A4	M42	19.7	65	A4 s/s
65690.480-A4	M48	22.7	75	A4 s/s



Lock Nuts Coarse Thread

Steel, self-colour

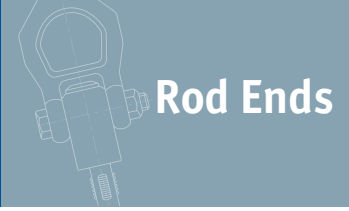

Rod Ends

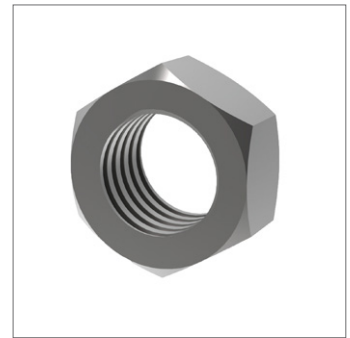
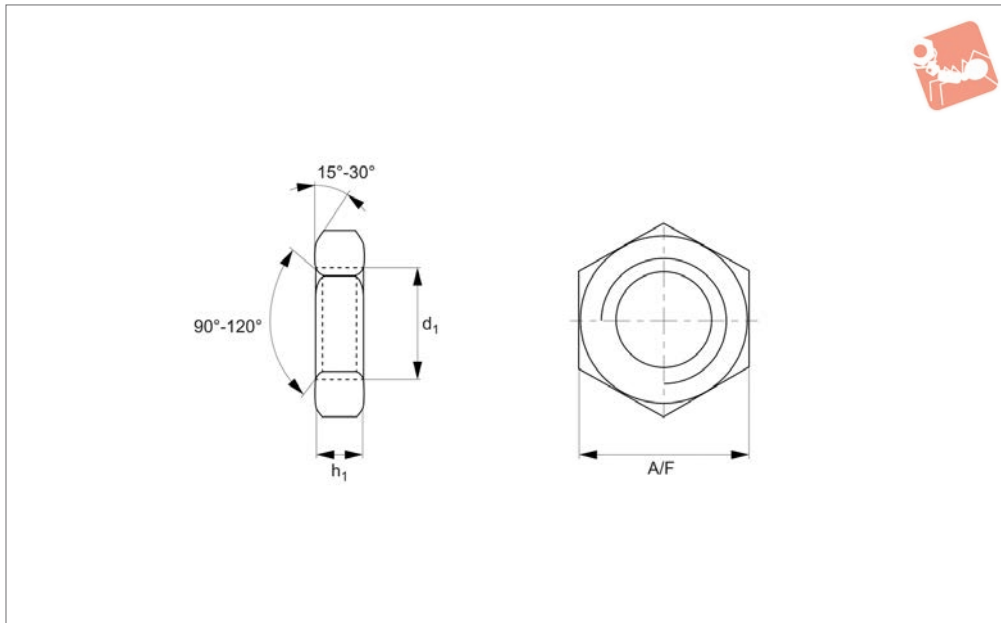

65690.SC

ROD ENDS

Material

Steel (class 4), self-colour.

threads.

For fine thread lock nuts see P0306.

Technical Notes

To DIN 439. Standard metric coarse pitch

Order No.	d_1	h_1	A/F	Material
65690.020-SC	M 2	0.95	4	Steel SC
65690.025-SC	M2,6	1.35	5	Steel SC
65690.030-SC	M 3	1.55	5.5	Steel SC
65690.040-SC	M 4	1.95	7	Steel SC
65690.050-SC	M 5	2.45	8	Steel SC
65690.060-SC	M 6	2.9	10	Steel SC
65690.080-SC	M 8	3.7	13	Steel SC
65690.100-SC	M10	4.7	17	Steel SC
65690.120-SC	M12	5.7	19	Steel SC
65690.140-SC	M14	6.42	22	Steel SC
65690.160-SC	M16	7.42	24	Steel SC
65690.180-SC	M18	8.42	27	Steel SC
65690.200-SC	M20	9.1	30	Steel SC
65690.220-SC	M22	9.9	34	Steel SC
65690.240-SC	M24	10.9	36	Steel SC
65690.270-SC	M27	12.4	41	Steel SC
65690.300-SC	M30	13.9	46	Steel SC
65690.330-SC	M33	15.4	50	Steel SC
65690.360-SC	M36	16.9	55	Steel SC

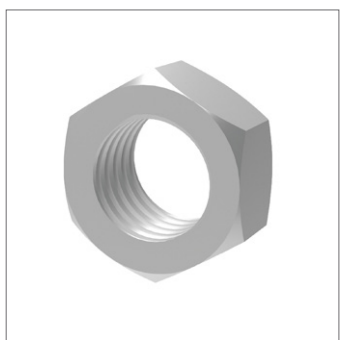
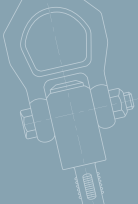

65690.ZP

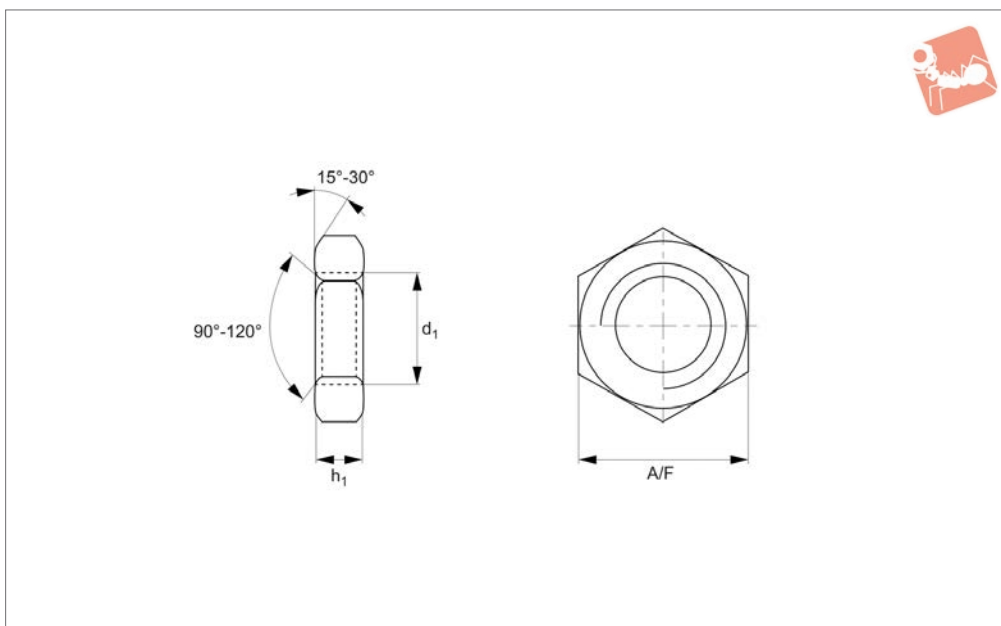

Material

Steel (class 4), zinc-plated.

threads.

For fine thread lock nuts see P0306.

Technical Notes

To DIN 439. Standard metric coarse pitch

Order No.	d ₁	h ₁ min.	A/F	Material
65690.020-ZP	M 2	0.95	4	Steel ZP
65690.025-ZP	M2,5	1.35	5	Steel ZP
65690.030-ZP	M 3	1.55	5.5	Steel ZP
65690.040-ZP	M 4	1.95	7	Steel ZP
65690.050-ZP	M 5	2.45	8	Steel ZP
65690.060-ZP	M 6	2.9	10	Steel ZP
65690.080-ZP	M 8	3.7	13	Steel ZP
65690.100-ZP	M10	4.7	17	Steel ZP
65690.120-ZP	M12	5.7	19	Steel ZP
65690.140-ZP	M14	6.42	22	Steel ZP
65690.160-ZP	M16	7.42	24	Steel ZP
65690.180-ZP	M18	8.42	27	Steel ZP
65690.200-ZP	M20	9.1	30	Steel ZP
65690.220-ZP	M22	9.9	34	Steel ZP
65690.240-ZP	M24	10.9	36	Steel ZP
65690.270-ZP	M27	12.4	41	Steel ZP
65690.300-ZP	M30	13.9	46	Steel ZP
65690.330-ZP	M33	15.4	50	Steel ZP
65690.360-ZP	M36	16.9	55	Steel ZP



Lock Nuts Left Hand Thread

303 series stainless

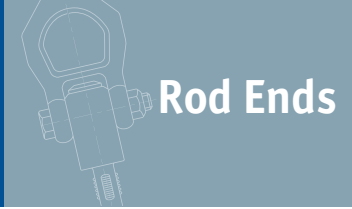

Rod Ends

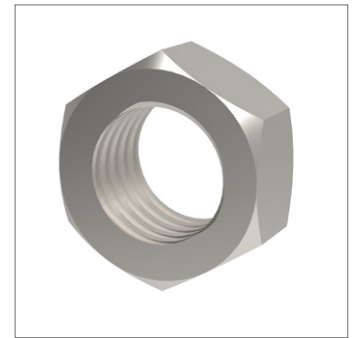
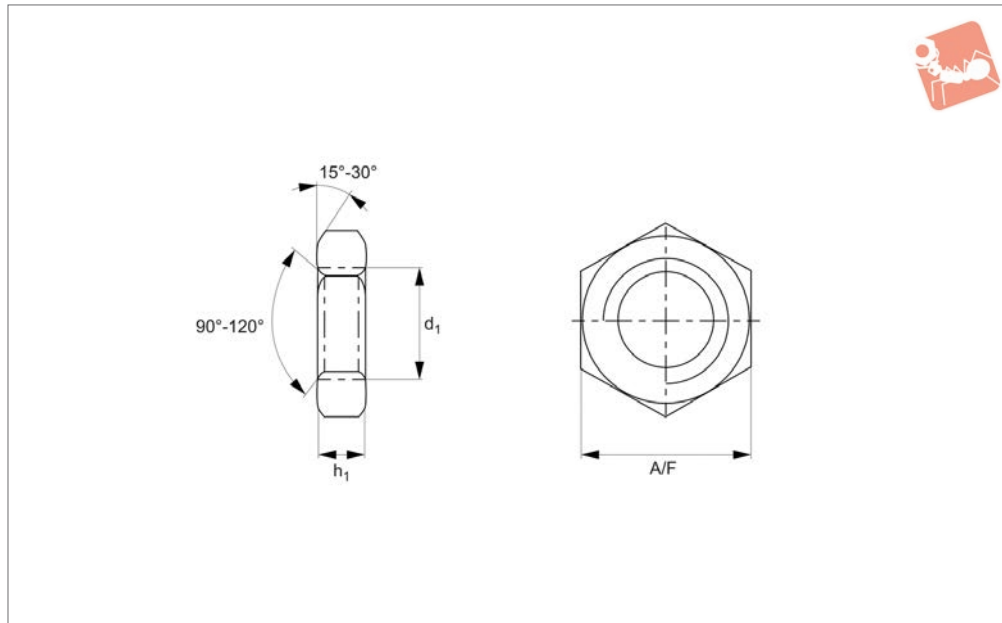

65691.A2

ROD ENDS

Material

Stainless steel (AISI 303, 1.4305).

Standard threads are coarse pitch.

Fine threads are indicated by an A & B suffix.

Technical Notes

To DIN 439. Left hand threads.

Order No.	d ₁	h ₁ min.	A/F	Material
65691.060-A2	M 6	2.9	10	A2 s/s
65691.080-A2	M 8	3.7	13	A2 s/s
65691.100-A2	M10	4.7	17	A2 s/s
65691.100-100-A2	M10x1,0	4.7	17	A2 s/s
65691.100-125-A2	M10x1,25	4.7	17	A2 s/s
65691.120-A2	M12	5.7	19	A2 s/s
65691.120-100-A2	M12x1,0	5.7	19	A2 s/s
65691.120-125-A2	M12x1,25	5.7	19	A2 s/s
65691.120-150-A2	M12x1,5	5.7	19	A2 s/s
65691.140-A2	M14	7	22	A2 s/s
65691.160-A2	M16	7.42	24	A2 s/s
65691.160-150-A2	M16x1,5	7.42	24	A2 s/s
65691.180-A2	M18	9	27	A2 s/s
65691.200-A2	M20	9.1	30	A2 s/s
65691.200-150-A2	M20x1,5	9.1	30	A2 s/s
65691.220-150-A2	M22x1,5	9.1	32	A2 s/s
65691.240-A2	M24	10.9	36	A2 s/s
65691.240-150-A2	M24x1,5	10.9	36	A2 s/s
65691.240-200-A2	M24x2,0	10.9	36	A2 s/s
65691.270-A2	M27	13.5	41	A2 s/s
65691.270-150-A2	M27x1,5	13.5	41	A2 s/s
65691.300-A2	M30	13.9	46	A2 s/s
65691.300-150-A2	M30x1,5	13.9	46	A2 s/s
65691.360-A2	M36	16.9	55	A2 s/s

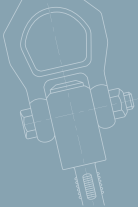

65691.A4

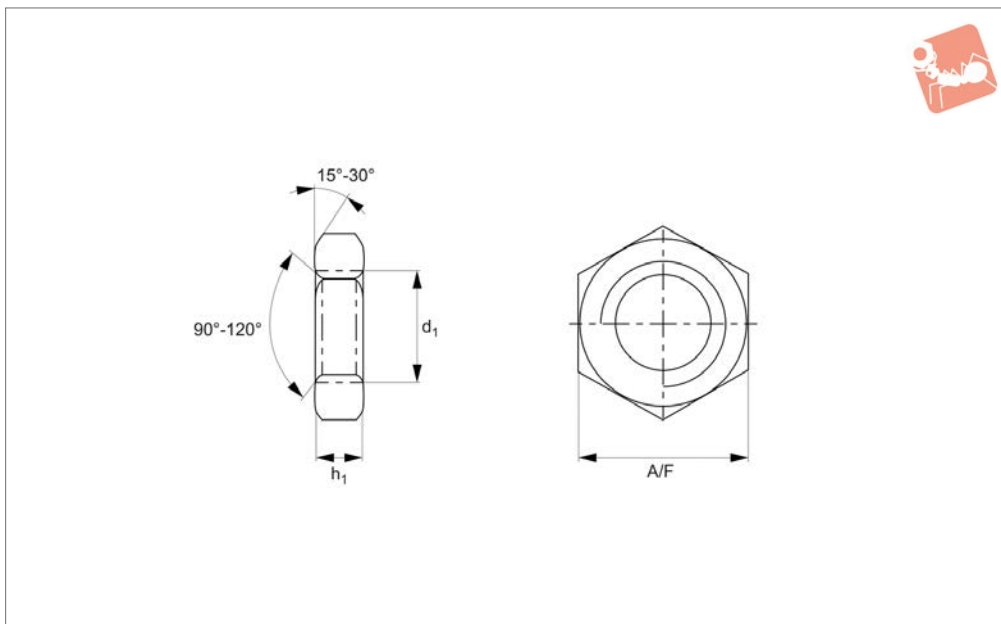

Material

Stainless steel (A4).

Standard threads are coarse pitch.
Fine threads are indicated by an A & B suffix.

Technical Notes

To DIN 439. Left hand threads.

Order No.	d ₁	h ₁	A/F	Material
65691.060-A4	M 6	2.9	10	A4 s/s
65691.080-A4	M 8	3.7	13	A4 s/s
65691.100-A4	M10	4.7	17	A4 s/s
65691.120-A4	M12	5.7	19	A4 s/s
65691.160-A4	M16	7.42	24	A4 s/s
65691.200-A4	M20	9.1	30	A4 s/s
65691.240-A4	M24	10.9	36	A4 s/s
65691.300-A4	M30	13.9	46	A4 s/s
65691.360-A4	M36	16.9	55	A4 s/s

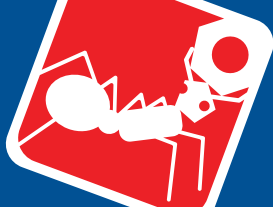

Lock Nuts Left Hand Thread

Steel, zinc-plated

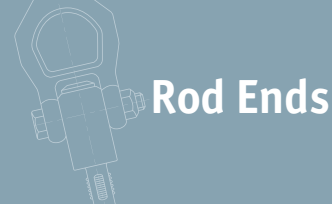

Rod Ends

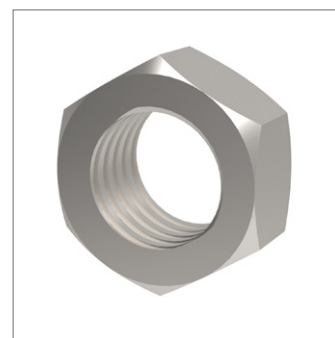
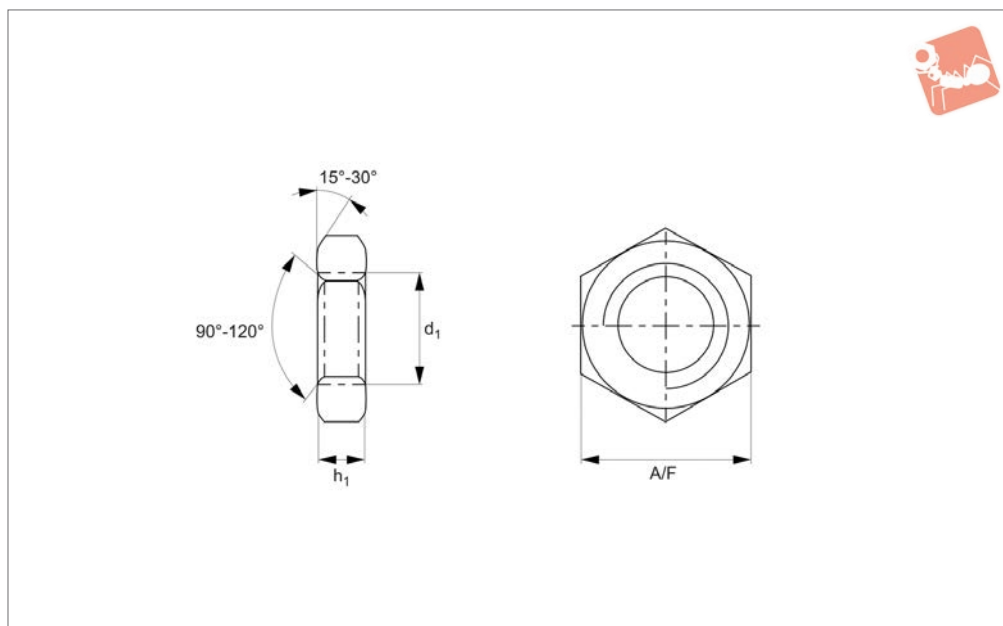

65691.ZP

ROD ENDS

Material

Steel (class 4), zinc-plated.

Standard threads are coarse pitch.

Fine threads are indicated by an A & B suffix.

Technical Notes

To DIN 439. Left hand threads.

Order No.	d ₁	h ₁	A/F	Material
65691.050-ZP	M 5	2.7	8	Steel ZP
65691.060-ZP	M 6	2.9	10	Steel ZP
65691.080-ZP	M 8	3.7	13	Steel ZP
65691.100-ZP	M10	4.7	17	Steel ZP
65691.100-100-ZP	M10x1,0	4.7	17	Steel ZP
65691.100-125-ZP	M10x1,25	4.7	17	Steel ZP
65691.120-ZP	M12	5.7	19	Steel ZP
65691.120-125-ZP	M12x1,25	5.7	19	Steel ZP
65691.120-150-ZP	M12x1,5	5.7	19	Steel ZP
65691.160-ZP	M16	7.42	24	Steel ZP
65691.160-150-ZP	M16x1,5	7.42	24	Steel ZP
65691.200-ZP	M20	9.1	30	Steel ZP
65691.200-150-ZP	M20x1,5	9.1	30	Steel ZP
65691.220-150-ZP	M22x1,5	9.1	32	Steel ZP
65691.240-ZP	M24	10.9	36	Steel ZP
65691.240-200-ZP	M24x2,0	10.9	36	Steel ZP
65691.300-ZP	M30	13.9	46	Steel ZP
65691.300-200-ZP	M30x2,0	13.9	46	Steel ZP

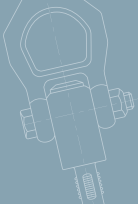

65692.A2

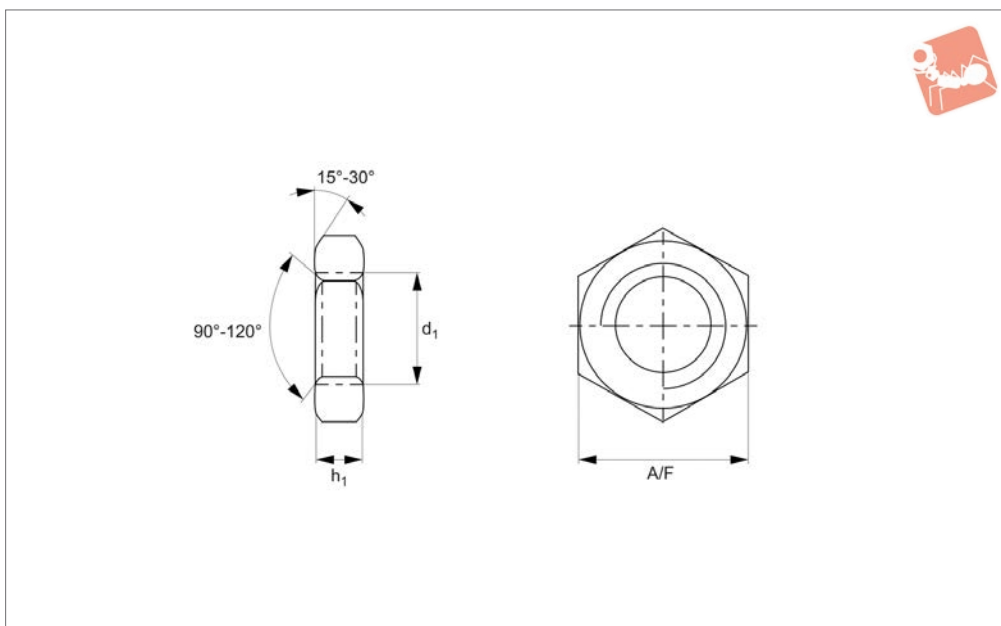

Material

Stainless steel (AISI 303, 1.4305).

Technical Notes

To DIN 439. Fine pitch threads.
For coarse thread lock nuts see P0305.

Order No.	d ₁	h ₁ min.	A/F	Material
65692.080-100-A2	M 8x1,0	3.7	13	A2 s/s
32700.W0515	M10x1,0	4.7	17	A2 s/s
65692.100-125-A2	M10x1,25	4.7	17	A2 s/s
65692.120-125-A2	M12x1,25	5.7	19	A2 s/s
65692.120-150-A2	M12x1,5	5.7	19	A2 s/s
65692.140-150-A2	M14x1,5	6.42	22	A2 s/s
65692.160-150-A2	M16x1,5	7.42	24	A2 s/s
65692.180-150-A2	M18x1,5	8.42	27	A2 s/s
65692.200-150-A2	M20x1,5	9.1	30	A2 s/s
65692.220-150-A2	M22x1,5	9.9	34	A2 s/s
65692.240-150-A2	M24x1,5	10.9	36	A2 s/s
65692.240-200-A2	M24x2,0	10.9	36	A2 s/s
65692.270-150-A2	M27x1,5	12.4	41	A2 s/s
65692.270-200-A2	M27x2,0	12.4	41	A2 s/s
65692.300-150-A2	M30x1,5	13.9	46	A2 s/s
65692.300-200-A2	M30x2,0	13.9	46	A2 s/s
65692.330-200-A2	M33x2,0	15.4	49	A2 s/s
65692.360-150-A2	M36x1,5	16.9	55	A2 s/s

Lock Nuts Fine Thread

A4 stainless

Rod Ends

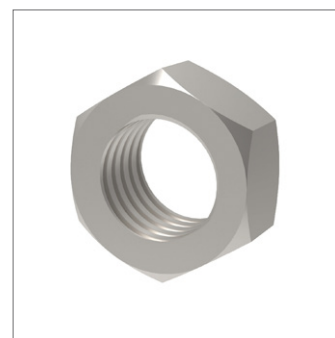
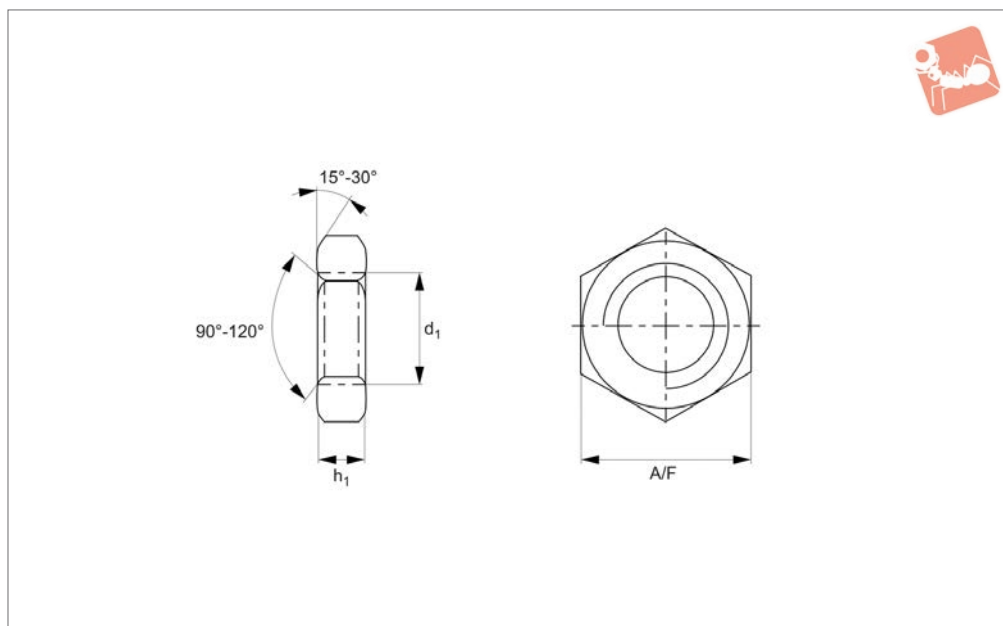
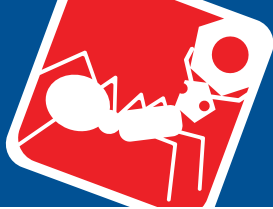

65692.A4

ROD ENDS

Material

Stainless steel (A4).

Technical Notes

To DIN 439. Fine pitch threads.
For coarse thread lock nuts see P0305.

Order No.	d ₁	h ₁	A/F	Material
65692.080-100-A4	M 8x1,0	3.7	13	A4 s/s
65692.100-100-A4	M10x1,0	4.7	17	A4 s/s
65692.100-125-A4	M10x1,25	4.7	17	A4 s/s
65692.120-125-A4	M12x1,25	5.7	19	A4 s/s
65692.120-150-A4	M12x1,5	5.7	19	A4 s/s
65692.140-150-A4	M14x1,5	6.42	22	A4 s/s
65692.160-150-A4	M16x1,5	7.42	24	A4 s/s
65692.180-150-A4	M18x1,5	8.42	27	A4 s/s
65692.200-150-A4	M20x1,5	9.1	30	A4 s/s
65692.220-150-A4	M22x1,5	9.9	34	A4 s/s
65692.240-150-A4	M24x1,5	10.9	36	A4 s/s
65692.240-200-A4	M24x2,0	10.9	36	A4 s/s
65692.270-150-A4	M27x1,5	12.4	41	A4 s/s
65692.270-200-A4	M27x2,0	12.4	41	A4 s/s
65692.300-150-A4	M30x1,5	13.9	46	A4 s/s
65692.300-200-A4	M30x2,0	13.9	46	A4 s/s
65692.330-200-A4	M33x2,0	15.4	49	A4 s/s
65692.360-150-A4	M36x1,5	16.9	55	A4 s/s

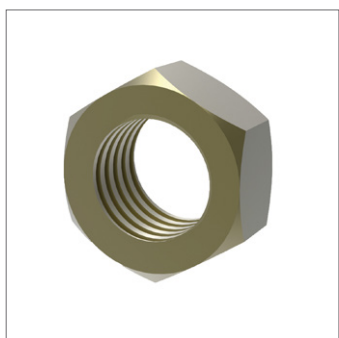
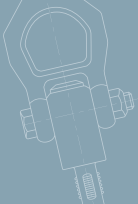

65692.BR

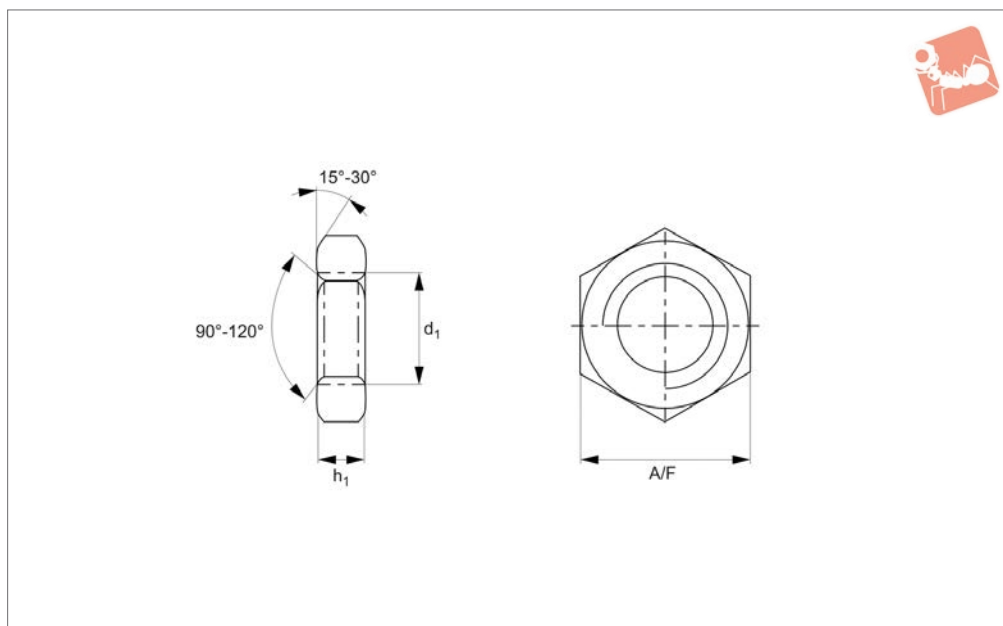

Material
Brass.

Technical Notes
To DIN 439. Fine pitch threads.
For coarse thread lock nuts see P0305.

Order No.	d	h	A/F	Material
65692.300-150-BR	M30x1,5	13.9	46	Brass

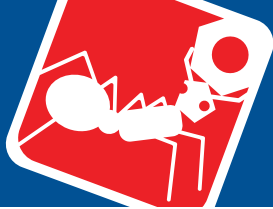

Lock Nuts Fine Thread

Steel, self-colour

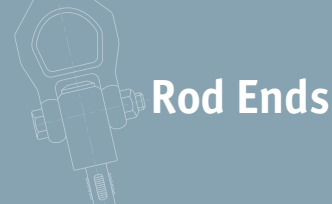

Rod Ends

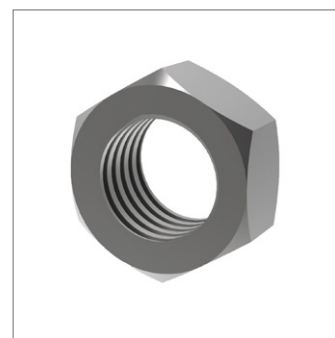
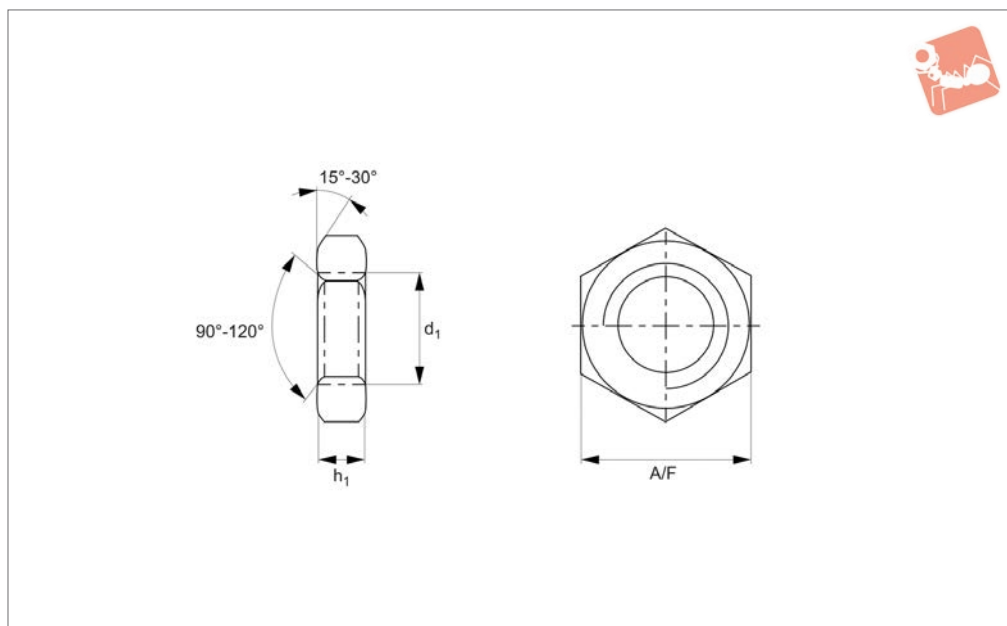

65692.SC

ROD ENDS

Material

Steel (class 4), self-colour.

Technical Notes

To DIN 439. Fine pitch threads.
For coarse thread lock nuts see P0305.

Order No.	d ₁	h ₁	A/F	Material
65692.100-100-SC	M10x1,0	4.7	17	Steel SC
65692.100-125-SC	M10x1,25	4.7	17	Steel SC
65692.120-125-SC	M12x1,25	5.7	19	Steel SC
65692.140-150-SC	M14x1,5	6.42	22	Steel SC
65692.160-150-SC	M16x1,5	7.42	24	Steel SC
65692.180-150-SC	M18x1,5	8.42	27	Steel SC
65692.200-150-SC	M20x1,5	9.1	30	Steel SC
65692.220-150-SC	M22x1,5	9.9	34	Steel SC
65692.240-150-SC	M24x1,5	10.9	36	Steel SC
65692.240-200-SC	M24x2,0	10.9	36	Steel SC
65692.270-150-SC	M27x1,5	12.4	41	Steel SC
65692.270-200-SC	M27x2,0	12.4	41	Steel SC
65692.300-150-SC	M30x1,5	13.9	46	Steel SC
65692.300-200-SC	M30x2,0	13.9	46	Steel SC
65692.330-200-SC	M33x2,0	15.4	49	Steel SC
65692.360-300-SC	M36x1,5	16.9	55	Steel SC
65692.420-150-SC	M42x1,5	21	65	Steel SC
65692.450-300-SC	M45x3,0	22.5	70	Steel SC
65692.560-200-SC	M56x2,0	28	85	Steel SC

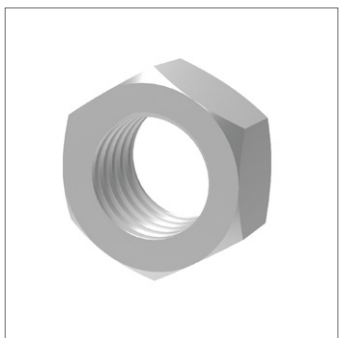
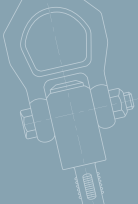

65692.ZP

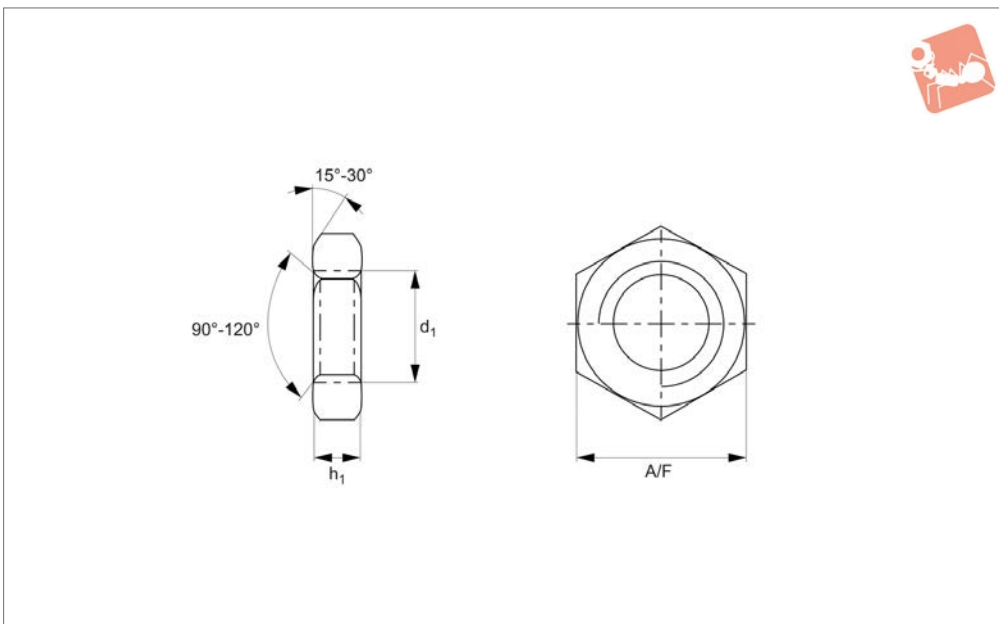

Material

Steel (class 4), zinc-plated.

Technical Notes

To DIN 439. Fine pitch threads.
For coarse thread lock nuts see P0305.

Order No.	d ₁	h ₁	A/F	Material
65692.080-100-ZP	M 8x1,0	3.7	13	Steel ZP
65692.100-100-ZP	M10x1,0	4.7	17	Steel ZP
65692.100-125-ZP	M10x1,25	4.7	17	Steel ZP
65692.120-125-ZP	M12x1,25	5.7	19	Steel ZP
65692.120-150-ZP	M12x1,5	5.7	19	Steel ZP
65692.140-150-ZP	M14x1,5	6.42	22	Steel ZP
65692.160-150-ZP	M16x1,5	7.42	24	Steel ZP
65692.180-150-ZP	M18x1,5	8.42	27	Steel ZP
65692.200-150-ZP	M20x1,5	9.1	30	Steel ZP
65692.220-150-ZP	M22x1,5	9.9	34	Steel ZP
65692.240-150-ZP	M24x1,5	10.9	36	Steel ZP
65692.240-200-ZP	M24x2,0	10.9	36	Steel ZP
65692.270-150-ZP	M27x1,5	12.4	41	Steel ZP
65692.270-200-ZP	M27x2,0	12.4	41	Steel ZP
65692.300-150-ZP	M30x1,5	13.9	46	Steel ZP
65692.300-200-ZP	M30x2,0	13.9	46	Steel ZP
65692.330-200-ZP	M33x2,0	15.4	49	Steel ZP
65692.360-200-ZP	M36x2,0	16.9	55	Steel ZP
65692.360-300-ZP	M36x3,0	16.9	55	Steel ZP

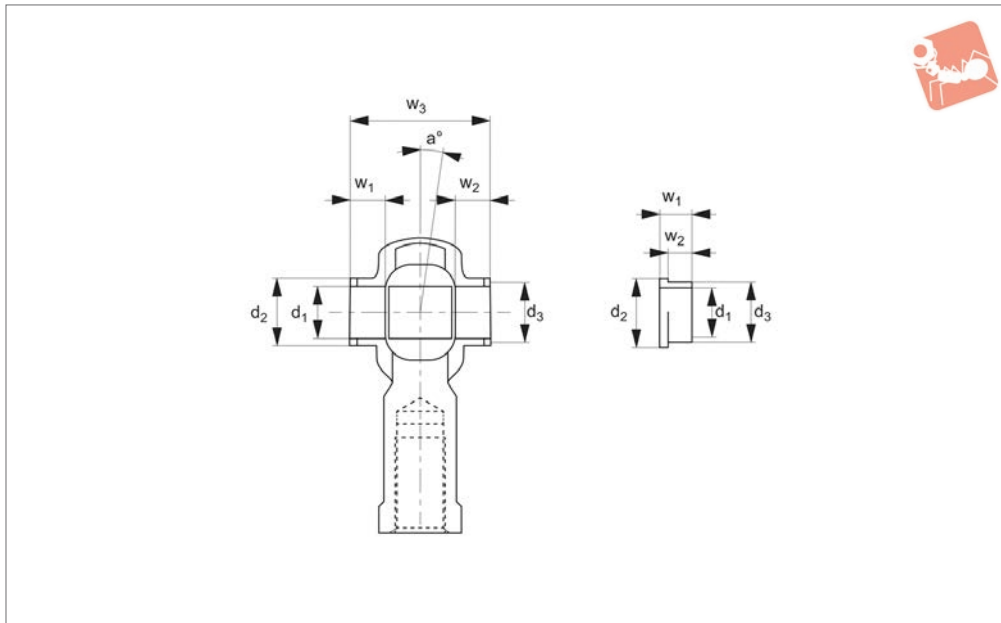
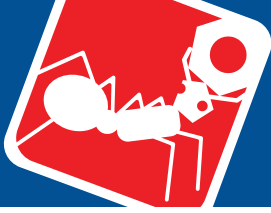

65970

ROD ENDS

Material

Rubber

protection of rod ends. For use with maintenance free series K rod ends.

Tips

Mounted easily with retaining pliers.

Technical Notes

Rubber protector caps for additional

Brass spacer bush available on request.
Temperature range: -20°C to + 110°C.

Order No.	Suitable for steel rod ends	Suitable for stainless steel rod ends	d ₁	d ₂	d ₃	w ₁	w ₂	w ₃	a°	Weight g
65970.W0006	R3550/R3551.006	R3565/R3566.006	6	11	8.7	6	4	21	13	3
65970.W0008	R3550/R3551.008	R3565/R3566.008	8	12	10.3	6	4	24	14	3
65970.W0010	R3550/R3551.010	R3565/R3566.010	10	14	12.5	6	4	26	14	5
65970.W0012	R3550/R3551.012	R3565/R3566.012	12	17	15.0	8	6	32	13	5
65970.W0014	R3550/R3551.014	R3565/R3566.014	14	19	16.8	8	6	35	16	7
65970.W0016	R3550/R3551.016	R3565/R3566.016	16	21	19.0	8	6	37	15	7
65970.W0018	R3550/R3551.018	R3565/R3566.018	18	25	21.8	8	6	39	15	7
65970.W0020	R3550/R3551.020	R3565/R3566.020	20	28	24.3	10	8	45	15	40
65970.W0022	R3550/R3551.022	R3565/R3566.022	22	29	25.7	10	8	48	15	40
65970.W0025	R3550/R3551.025	R3565/R3566.025	25	33	29.7	10	8	51	15	40

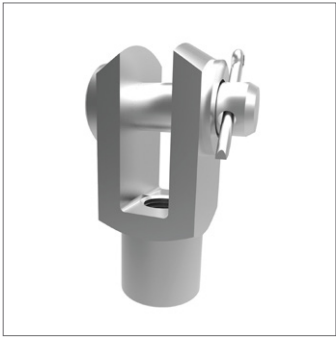

65600

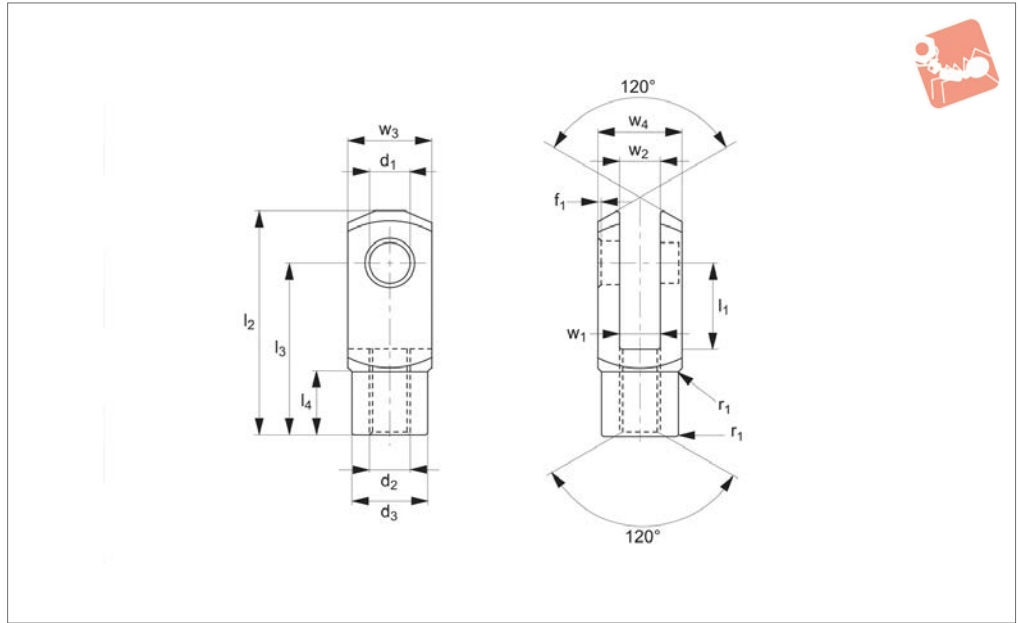

Material

Steel 1.0718 (11SMnPb30k), silver zinc plated.

Technical Notes

M5-M16: DIN 71 752/DIN ISO 8140.

M18-M48: Similar to DIN 71 752/DIN ISO 8140 and according to CETOP standard.

Tips

Standard thread is right hand, (for left hand, see 65602).

Assembly is made up using 65630 clevis

joint, 65660 clevis pin, P0330 washer, and 65674 split cotter pin.

Important Notes

For sizes M4-M12, f_1 and $r_1=0,5$, for sizes M14-M16, f_1 and $r_1=1$

For sizes M18-M20, $f_1=1$, $r_1=1,5$, for M24 f_1 and $r_1=1,5$, for sizes M27-M30, $f_1=1,5$, $r_1=2$

For M36 $f_1=2$, $r_1=3$, for sizes M42-M48, $f_1=3$, $r_1=5$, for r_1 , radius or 45° bevelling.

Other Tolerances:-

w_4 : M4-M16 = +0,3 -0,16

M18-M48 = +0,5 -0,2

w_2 : size 4x8-10x20 = B13

All others +0,7 +0,15

d_3 : M4-M16 = ±0,3

l_2 : size 4x8-6x12 = ±0,3

All others ±0,4

l_3 : M4-M16 = ±0,2

M18-M48 = ±0,3

r_1 : M18-M48 = ±0,5

Order No.	Size	Thread hand	Thread type	d_1 tol. H9	l_1 ±0.5	d_2	d_3	l_2 ±0.5	l_3	l_4	w_1 tol. B13	w_2	w_3 tol. h11	w_4	Weight g
65600.W0051	5x10	Right	Coarse	5	10	M5	9	26	20	7.5	5	5	10	10	9
65600.W0052	5x20	Right	Coarse	5	20	M5	9	36	30	7.5	5	5	10	10	13
65600.W0061	6x12	Right	Coarse	6	12	M6	10	31	24	9.0	6	6	12	12	15
65600.W0062	6x24	Right	Coarse	6	24	M6	10	43	36	9.0	6	6	12	12	21
65600.W0081	8x16	Right	Coarse	8	16	M8	14	42	32	12.0	8	8	16	16	37
65600.W0082	8x16	Right	Fine	8	16	M8x1	14	42	32	12.0	8	8	16	16	37
65600.W0083	8x32	Right	Coarse	8	32	M8	14	58	48	12.0	8	8	16	16	54
65600.W0084	8x32	Right	Fine	8	32	M8x1	14	58	48	12.0	8	8	16	16	54
65600.W0102	10x20	Right	Coarse	10	20	M10	18	52	40	15.0	10	10	20	20	74
65600.W0103	10x20	Right	Fine	10	20	M10x1,25	18	52	40	15.0	10	10	20	20	74
65600.W0104	10x40	Right	Coarse	10	40	M10	18	72	60	15.0	10	10	20	20	116
65600.W0105	10x40	Right	Fine	10	40	M10x1,25	18	72	60	15.0	10	10	20	20	116
65600.W0122	12x24	Right	Coarse	12	24	M12	20	62	48	18.0	12	12	24	24	121
65600.W0123	12x24	Right	Fine	12	24	M12x1,25	20	62	48	18.0	12	12	24	24	121
65600.W0124	12x48	Right	Coarse	12	48	M12	20	86	72	18.0	12	12	24	24	175
65600.W0125	12x48	Right	Fine	12	48	M12x1,25	20	86	72	18.0	12	12	24	24	175
65600.W0142	14x28	Right	Coarse	14	28	M14	24	72	56	22.5	14	14	27	27	178
65600.W0143	14x28	Right	Fine	14	28	M14x1,5	24	72	56	22.5	14	14	27	27	178
65600.W0145	14x56	Right	Coarse	14	56	M14	24	101	85	22.5	14	14	27	27	258
65600.W0146	14x56	Right	Fine	14	56	M14x1,5	24	101	85	22.5	14	14	27	27	258
65600.W0163	16x32	Right	Coarse	16	32	M16	26	83	64	24.0	16	16	32	32	282
65600.W0164	16x32	Right	Fine	16	32	M16x1,5	26	83	64	24.0	16	16	32	32	282
65600.W0166	16x64	Right	Coarse	16	64	M16	26	115	96	24.0	16	16	32	32	411
65600.W0167	16x64	Right	Fine	16	64	M16x1,5	26	115	96	24.0	16	16	32	32	411
65600.W0183	18x36	Right	Coarse	18	36	M18	30	94	72	27.0	18	18	36	36	390



Steel Clevis Joint with Pin

silver zinc plated

Clevis Joints



Order No.	Size	Thread hand	Thread type	d ₁ tol. H9	l ₁ ±0.5	d ₂	d ₃	l ₂ ±0.5	l ₃	l ₄	w ₁ tol. B13	w ₂	w ₃ tol. h11	w ₄	Weight g
65600.W0184	18x36	Right	Fine	18	36	M18x1,5	30	94	72	27.0	18	18	36	36	390
65600.W0204	20x40	Right	Coarse	20	40	M20	34	105	80	30.0	20	20	40	40	550
65600.W0205	20x40	Right	Fine	20	40	M20x1,5	34	105	80	30.0	20	20	40	40	550
65600.W0208	20x80	Right	Coarse	20	80	M20	34	145	120	30.0	20	20	40	40	800
65600.W0209	20x80	Right	Fine	20	80	M20x1,5	34	145	120	30.0	20	20	40	40	800
65600.W0255	25x50	Right	Coarse	25	50	M24	42	132	100	36.0	25	25	50	50	1100
65600.W0256	25x50	Right	Fine	25	50	M24x2	42	132	100	36.0	25	25	50	50	1100
65600.W0285	28x56	Right	Coarse	28	56	M27	48	148	112	40.0	28	28	55	55	1500
65600.W0286	28x56	Right	Fine	28	56	M27x2	48	148	112	40.0	28	28	55	55	1500
65600.W0305	30x54	Right	Fine	30	54	M27x2	48	148	110	40.0	30	30	55	55	1440
65600.W0306	30x60	Right	Coarse	30	60	M30	52	160	120	42.0	30	30	60	60	1970
65600.W0307	30x60	Right	Fine	30	60	M30x2	52	160	120	42.0	30	30	60	60	1970
65600.W0355	35x54	Right	Fine	35	54	M36x2	60	188	144	54.0	35	35	70	70	2930
65600.W0357	35x72	Right	Coarse	35	72	M36	60	188	144	54.0	35	35	70	70	2930
65600.W0358	35x72	Right	Fine	35	72	M36x2	60	188	144	54.0	35	35	70	70	2930
65600.W0367	36x72	Right	Coarse	35	72	M36	60	188	144	54.0	36	36	70	70	2930
65600.W0368	36x72	Right	Fine	35	72	M36x2	60	188	144	54.0	36	36	70	70	2930
65600.W0408	40x84	Right	Fine	40	84	M42x2	70	232	168	63.5	40	40	85	85	5640
65600.W0428	42x84	Right	Coarse	42	84	M42	70	232	168	63.5	42	42	85	85	5340
65600.W0429	42x84	Right	Fine	42	84	M42x2	70	232	168	63.5	42	42	85	85	5340
65600.W0509	50x96	Right	Coarse	50	96	M48	82	265	192	73.0	50	50	96	96	7860
65600.W0510	50x96	Right	Fine	50	96	M48x2	82	265	192	73.0	50	50	96	96	7860

CLEVIS JOINTS

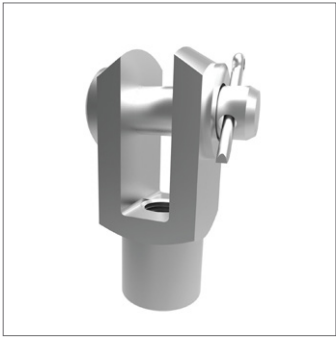

65602

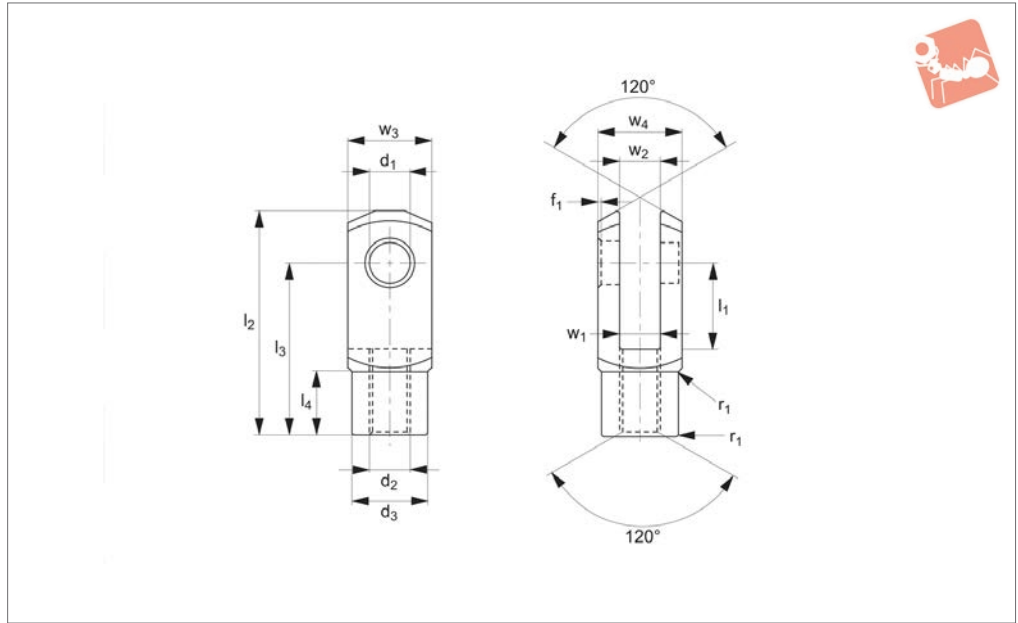

Material

Steel 1.0718 (11SMnPb30k), silver zinc plated.

Technical Notes

M5-M16: DIN 71 752/DIN ISO 8140.

M18-M48: Similar to DIN 71 752/DIN ISO 8140 and according to CETOP standard.

Tips

Assembly is made up using the 65631 clevis joint, 65660 clevis pin, P0330

washer, and 65674 split cotter pin.

Important Notes

For sizes M4-M12, f_1 and $r_1=0,5$, for sizes M14-M16, f_1 and $r_1=1$

For sizes M18-M20, $f_1=1$, $r_1=1,5$, for M24 f_1 and $r_1=1,5$, for sizes M27-M30, $f_1=1,5$, $r_1=2$

For M36 $f_1=2$, $r_1=3$, for sizes M42-M48, $f_1=3$, $r_1=5$, for r_1 , radius or 45° bevelling.

Other Tolerances:-

w_4 : M4-M16 = $+0,3 -0,16$

M18-M48 = $+0,5 -0,2$

w_2 : size 4x8-10x20 = B13

All others $+0,7 +0,15$

d_3 : M4-M16 = $\pm 0,3$

l_2 : size 4x8-6x12 = $\pm 0,3$

All others $\pm 0,4$

l_3 : M4-M16 = $\pm 0,2$

M18-M48 = $\pm 0,3$

r_1 : M18-M48 = $\pm 0,5$

Order No.	Size	Thread hand	Thread type	d_1 tol. H9	l_1 $\pm 0,5$	d_2	d_3	l_2 $\pm 0,5$	l_3	l_4	w_1 tol. B13	w_2	w_3 tol. h11	w_4	Weight g
65602.W0051	5x10	Left	Coarse	5	10	M5	9	26	20	7.5	5	5	10	10	9
65602.W0052	5x20	Left	Coarse	5	20	M5	9	36	30	7.5	5	5	10	10	13
65602.W0061	6x12	Left	Coarse	6	12	M6	10	31	24	9.0	6	6	12	12	15
65602.W0062	6x24	Left	Coarse	6	24	M6	10	43	36	9.0	6	6	12	12	21
65602.W0081	8x16	Left	Coarse	8	16	M8	14	42	32	12.0	8	8	16	16	37
65602.W0082	8x16	Left	Fine	8	16	M8x1	14	42	32	12.0	8	8	16	16	37
65602.W0083	8x32	Left	Coarse	8	32	M8	14	58	48	12.0	8	8	16	16	54
65602.W0084	8x32	Left	Fine	8	32	M8x1	14	58	48	12.0	8	8	16	16	54
65602.W0102	10x20	Left	Coarse	10	20	M10	18	52	40	15.0	10	10	20	20	74
65602.W0103	10x20	Left	Fine	10	20	M10x1,25	18	52	40	15.0	10	10	20	20	74
65602.W0104	10x40	Left	Coarse	10	40	M10	18	72	60	15.0	10	10	20	20	116
65602.W0105	10x40	Left	Fine	10	40	M10x1,25	18	72	60	15.0	10	10	20	20	116
65602.W0122	12x24	Left	Coarse	12	24	M12	20	62	48	18.0	12	12	24	24	121
65602.W0123	12x24	Left	Fine	12	24	M12x1,25	20	62	48	18.0	12	12	24	24	121
65602.W0124	12x48	Left	Coarse	12	48	M12	20	86	72	18.0	12	12	24	24	175
65602.W0125	12x48	Left	Fine	12	48	M12x1,25	20	86	72	18.0	12	12	24	24	175
65602.W0142	14x28	Left	Coarse	14	28	M14	24	72	56	22.5	14	14	27	27	178
65602.W0143	14x28	Left	Fine	14	28	M14x1,5	24	72	56	22.5	14	14	27	27	178
65602.W0145	14x56	Left	Coarse	14	56	M14	24	101	85	22.5	14	14	27	27	258
65602.W0146	14x56	Left	Fine	14	56	M14x1,5	24	101	85	22.5	14	4	27	27	258
65602.W0163	16x32	Left	Coarse	16	32	M16	26	83	64	24.0	16	16	32	32	282
65602.W0164	16x32	Left	Fine	16	32	M16x1,5	26	83	64	24.0	16	16	32	32	282
65602.W0166	16x64	Left	Coarse	16	64	M16	26	115	96	24.0	16	16	32	32	411
65602.W0167	16x64	Left	Fine	16	64	M16x1,5	26	115	96	24.0	16	16	32	32	411
65602.W0183	18x36	Left	Coarse	18	36	M18	30	94	72	27.0	18	18	36	36	390
65602.W0184	18x36	Left	Fine	18	36	M18x1,5	30	94	72	27.0	18	18	36	36	390



Steel Clevis Joints with Pin

left hand thread - silver zinc plated

Clevis Joints



Order No.	Size	Thread hand	Thread type	d ₁ tol. H9	l ₁ ±0.5	d ₂	d ₃	l ₂ ±0.5	l ₃	l ₄	w ₁ tol. B13	w ₂	w ₃ tol. h11	w ₄	Weight g
65602.W0204	20x40	Left	Coarse	20	40	M20	34	105	80	30.0	20	20	40	40	550
65602.W0205	20x40	Left	Fine	20	40	M20x1,5	34	105	80	30.0	20	20	40	40	550
65602.W0208	20x80	Left	Coarse	20	80	M20	34	145	120	30.0	20	20	40	40	800
65602.W0209	20x80	Left	Fine	20	80	M20x1,5	34	145	120	30.0	20	20	40	40	800
65602.W0255	25x50	Left	Coarse	25	50	M24	42	132	100	36.0	25	25	50	50	1100
65602.W0256	25x50	Left	Fine	25	50	M24x2	42	132	100	36.0	25	25	50	50	1100
65602.W0285	28x56	Left	Coarse	28	56	M27	48	148	112	40.0	28	28	55	55	1500
65602.W0286	28x56	Left	Fine	28	56	M27x2	48	148	112	40.0	28	28	55	55	1500
65602.W0305	30x54	Left	Fine	30	54	M27x2	48	148	110	40.0	30	30	55	55	1440
65602.W0306	30x60	Left	Coarse	30	60	M30	52	160	120	42.0	30	30	60	60	1970
65602.W0307	30x60	Left	Fine	30	60	M30x2	52	160	120	42.0	30	30	60	60	1970
65602.W0355	35x54	Left	Fine	35	54	M36x2	60	188	144	54.0	35	35	70	70	2930
65602.W0357	35x72	Left	Course	35	72	M36	60	188	144	54.0	35	35	70	70	2930
65602.W0358	35x72	Left	Fine	35	72	M36x2	60	188	144	54.0	35	35	70	70	2930
65602.W0367	36x72	Left	Course	35	72	M36	60	188	144	54.0	36	36	70	70	2930
65602.W0368	36x72	Left	Fine	35	72	M36x2	60	188	144	54.0	36	36	70	70	2930
65602.W0408	40x84	Left	Fine	40	84	M42x2	70	232	168	63.5	40	40	85	85	5640
65602.W0428	42x84	Left	Coarse	42	84	M42	70	232	168	63.5	42	42	85	85	5340
65602.W0429	42x84	Left	Fine	42	84	M42x2	70	232	168	63.5	42	42	85	85	5340
65602.W0509	50x96	Left	Coarse	50	96	M48	82	265	192	73.0	50	50	96	96	7860
65602.W0510	50x96	Left	Fine	50	96	M48x2	82	265	192	73.0	50	50	96	96	7860

CLEVIS JOINTS



65618

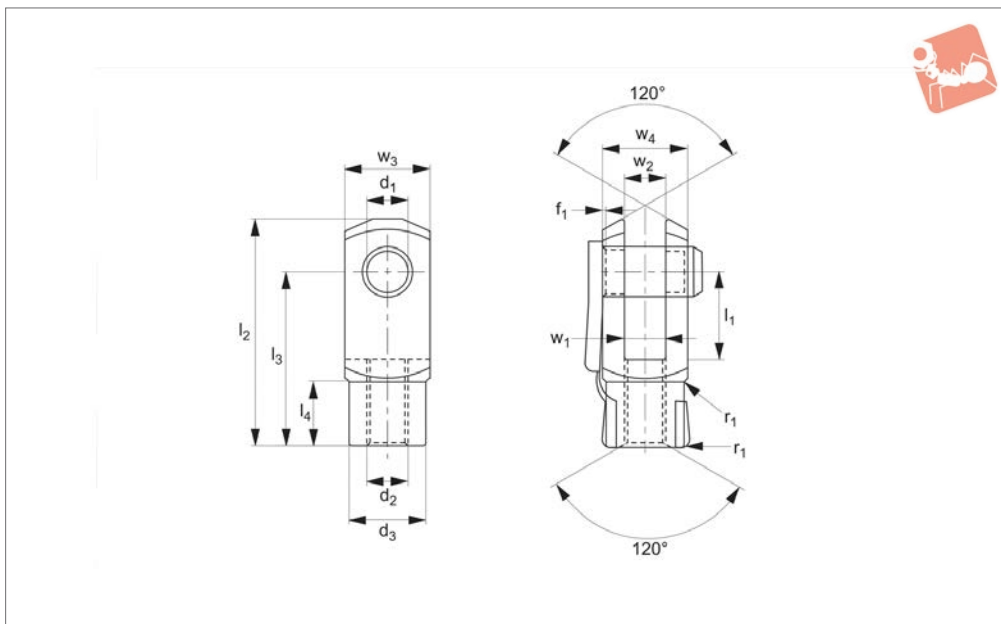

Material

Steel 1.0718 (11SMnPb30k), silver zinc plated.

Technical Notes

M4-M16: DIN 71 752/DIN ISO 8140.

M20: Similar to DIN 71 752/DIN ISO 8140 and according to CETOP standard.

Tips

For yellow zinc plated version see R3398, standard thread is right hand, (for left hand, see 65620).

Assembly made up using 65630 clevis joint and 65684 clevis retention clip.

Important Notes

For sizes M4-M12, f_1 and $r_1=0,5$, for sizes M14-M16, f_1 and $r_1=1$

For sizes M18-M20, $f_1=1$, $r_1=1,5$, for M24 f_1 and $r_1=1,5$, for sizes M27-M30, $f_1=1,5$, $r_1=2$

For M36 $f_1=2$, $r_1=3$, for sizes M42-M48, $f_1=3$, $r_1=5$, for r_1 , radius or 45° bevelling.

Other Tolerances:-

w_4 : M4-M16 = +0,3 -0,16

M18-M48 = +0,5 -0,2

w_2 : size 4x8-10x20 = B13

All others +0,7 +0,15

d_3 : M4-M16 = ±0,3

l_2 : size 4x8-6x12 = ±0,3

All others ±0,4

l_3 : M4-M16 = ±0,2

M18-M48 = ±0,3

r_1 : M18-M48 = ±0,5

Order No.	Size	Thread hand	Thread type	d_1 tol. H9	l_1 ±0.5	d_2	d_3	l_2 ±0.5	l_3	l_4	w_1 tol. B13	w_2	w_3 tol. h11	w_4	Weight g
65618.W0040	4x8	Right	Coarse	4	8	M4	8	21	16	6.0	4	4	8	8	5
65618.W0051	5x10	Right	Coarse	5	10	M5	9	26	20	7.5	5	5	10	10	9
65618.W0052	5x20	Right	Coarse	5	20	M5	9	36	30	7.5	5	5	10	10	13
65618.W0061	6x12	Right	Coarse	6	12	M6	10	31	24	9.0	6	6	12	12	15
65618.W0062	6x24	Right	Coarse	6	24	M6	10	43	36	9.0	6	6	12	12	21
65618.W0081	8x16	Right	Coarse	8	16	M8	14	42	32	12.0	8	8	16	16	37
65618.W0082	8x16	Right	Fine	8	16	M8x1	14	42	32	12.0	8	8	16	16	37
65618.W0083	8x32	Right	Coarse	8	32	M8	14	58	48	12.0	8	8	16	16	54
65618.W0084	8x32	Right	Fine	8	32	M8x1	14	58	48	12.0	8	8	16	16	54
65618.W0102	10x20	Right	Coarse	10	20	M10	18	52	40	15.0	10	10	20	20	74
65618.W0103	10x20	Right	Fine	10	20	M10x1,25	18	52	40	15.0	10	10	20	20	74
65618.W0104	10x40	Right	Coarse	10	40	M10	18	72	60	15.0	10	10	20	20	116
65618.W0105	10x40	Right	Fine	10	40	M10x1,25	18	72	60	15.0	10	10	20	20	116
65618.W0122	12x24	Right	Coarse	12	24	M12	20	62	48	18.0	12	12	24	24	121
65618.W0123	12x24	Right	Fine	12	24	M12x1,25	20	62	48	18.0	12	12	24	24	121
65618.W0124	12x48	Right	Coarse	12	48	M12	20	86	72	18.0	12	12	24	24	175
65618.W0125	12x48	Right	Fine	12	48	M12x1,25	20	86	72	18.0	12	12	24	24	175
65618.W0142	14x28	Right	Coarse	14	28	M14	24	72	56	22.5	14	14	27	27	178
65618.W0143	14x28	Right	Fine	14	28	M14x1,5	24	72	56	22.5	14	14	27	27	178
65618.W0145	14x56	Right	Coarse	14	56	M14	24	101	85	22.5	14	14	27	27	258
65618.W0146	14x56	Right	Fine	14	56	M14x1,5	24	101	85	22.5	14	14	27	27	258
65618.W0163	16x32	Right	Coarse	16	32	M16	26	83	64	24.0	16	16	32	32	282
65618.W0164	16x32	Right	Fine	16	32	M16x1,5	26	83	64	24.0	16	16	32	32	282
65618.W0166	16x64	Right	Coarse	16	64	M16	26	115	96	24.0	16	16	32	32	411
65618.W0167	16x64	Right	Fine	16	64	M16x1,5	26	115	96	24.0	16	16	32	32	411



Steel Clevis Joints with Retention

silver zinc plated

Clevis Joints



Order No.	Size	Thread hand	Thread type	d ₁ tol. H9	l ₁ ±0.5	d ₂	d ₃	l ₂ ±0.5	l ₃	l ₄	w ₁ tol. B13	w ₂	w ₃ tol. h11	w ₄	Weight g
65618.W0204	20x40	Right	Coarse	20	40	M20	34	105	80	30.0	20	20	40	40	550
65618.W0205	20x40	Right	Fine	20	40	M20x1,5	34	105	80	30.0	20	20	40	40	550

CLEVIS JOINTS



65620

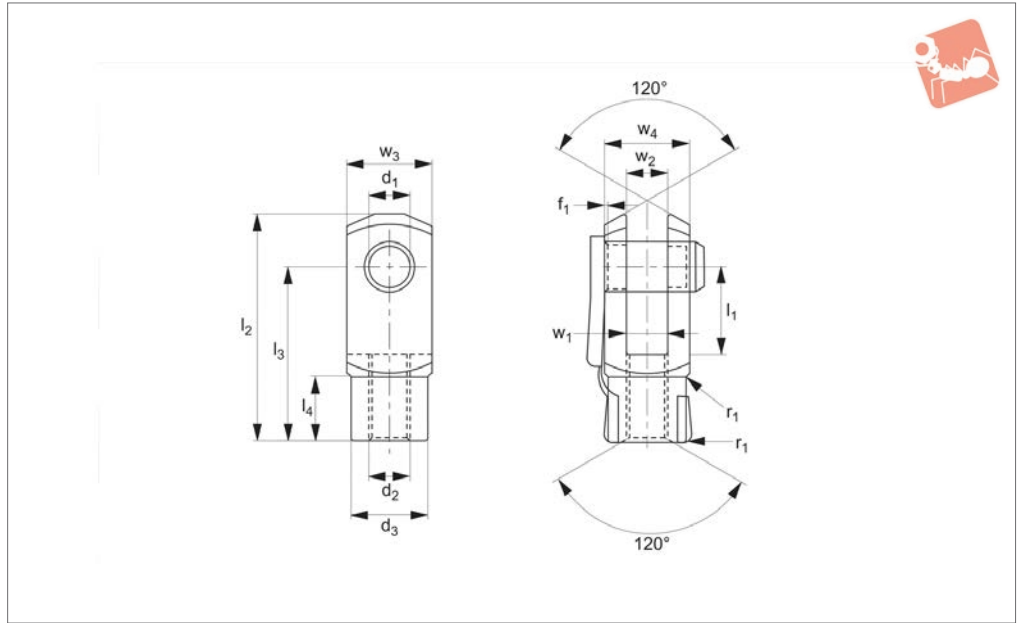

Material

Steel 1.0718 (11SMnPb30k), silver zinc plated.

Technical Notes

M4-M16: DIN 71 752/DIN ISO 8140.

M20: Similar to DIN 71 752/DIN ISO 8140 and according to CETOP standard.

Tips

For yellow zinc plated version see R3399, assembly made up using 65631 clevis joint

and 65684 clevis retention clip.

Important Notes

For sizes M4-M12, f_1 and $r_1=0,5$

For sizes M4-M16, f_1 and $r_1=1$

For sizes M20, $f_1=1$, $r_1=1,5$

For r_1 , radius or 45° bevelling.

Other Tolerances:-

w_4 : M4-M16 = +0,3 -0,16

M20 = +0,5 -0,2

w_2 : size 4x8-10x20 = B13

All others +0,7 +0,15

d_3 : M4-M16 = ±0,3

l_2 : size 4x8-6x12 = ±0,3

All others ±0,4

l_3 : M4-M16 = ±0,2

M20 = ±0,3

r_1 : M20 = ±0,5

Order No.	Size	Thread hand	Thread type	d_1 tol. H9	l_1 ±0.5	d_2	d_3	l_2 ±0.5	l_3	l_4	w_1 tol. B13	w_2	w_3 tol. h11	w_4	Weight g
65620.W0040	4x8	Left	Coarse	4	8	M4	8	21	16	6.0	4	4	8	8	5
65620.W0051	5x10	Left	Coarse	5	10	M5	9	26	20	7.5	5	5	10	10	9
65620.W0052	5x20	Left	Coarse	5	20	M5	9	36	30	7.5	5	5	10	10	13
65620.W0061	6x12	Left	Coarse	6	12	M6	10	31	24	9.0	6	6	12	12	15
65620.W0062	6x24	Left	Coarse	6	24	M6	10	43	36	9.0	6	6	12	12	21
65620.W0081	8x16	Left	Coarse	8	16	M8	14	42	32	12.0	8	8	16	16	37
65620.W0082	8x16	Left	Fine	8	16	M8x1	14	42	32	12.0	8	8	16	16	37
65620.W0083	8x32	Left	Coarse	8	32	M8	14	58	48	12.0	8	8	16	16	54
65620.W0084	8x32	Left	Fine	8	32	M8x1	14	58	48	12.0	8	8	16	16	54
65620.W0102	10x20	Left	Coarse	10	20	M10	18	52	40	15.0	10	10	20	20	74
65620.W0103	10x20	Left	Fine	10	20	M10x1,25	18	52	40	15.0	10	10	20	20	74
65620.W0104	10x40	Left	Coarse	10	40	M10	18	72	60	15.0	10	10	20	20	116
65620.W0105	10x40	Left	Fine	10	40	M10x1,25	18	72	60	15.0	10	10	20	20	116
65620.W0122	12x24	Left	Coarse	12	24	M12	20	62	48	18.0	12	12	24	24	121
65620.W0123	12x24	Left	Fine	12	24	M12x1,25	20	62	48	18.0	12	12	24	24	121
65620.W0124	12x48	Left	Coarse	12	48	M12	20	86	72	18.0	12	12	24	24	175
65620.W0125	12x48	Left	Fine	12	48	M12x1,25	20	86	72	18.0	12	12	24	24	175
65620.W0142	14x28	Left	Coarse	14	28	M14	24	72	56	22.5	14	14	27	27	178
65620.W0143	14x28	Left	Fine	14	28	M14x1,5	24	72	56	22.5	14	14	27	27	178
65620.W0145	14x56	Left	Coarse	14	56	M14	24	101	85	22.5	14	14	27	27	258
65620.W0146	14x56	Left	Fine	14	56	M14x1,5	24	101	85	22.5	14	14	27	27	258
65620.W0163	16x32	Left	Coarse	16	32	M16	26	83	64	24.0	16	16	32	32	282
65620.W0164	16x32	Left	Fine	16	32	M16x1,5	26	83	64	24.0	16	16	32	32	282
65620.W0166	16x64	Left	Coarse	16	64	M16	26	115	96	24.0	16	16	32	32	411
65620.W0167	16x64	Left	Fine	16	64	M16x1,5	26	115	96	24.0	16	16	32	32	411
65620.W0204	20x40	Left	Coarse	20	40	M20	34	105	80	30.0	20	20	40	40	550



Steel Clevis Joints with Retention

left hand thread - silver zinc plated

Clevis Joints



Order No.	Size	Thread hand	Thread type	d ₁ tol. H9	l ₁ ±0.5	d ₂	d ₃	l ₂ ±0.5	l ₃	l ₄	w ₁ tol. B13	w ₂	w ₃ tol. h11	w ₄	Weight g
65620.W0205	20x40	Left	Fine	20	40	M20x1,5	34	105	80	30.0	20	20	40	40	550

CLEVIS JOINTS



65630

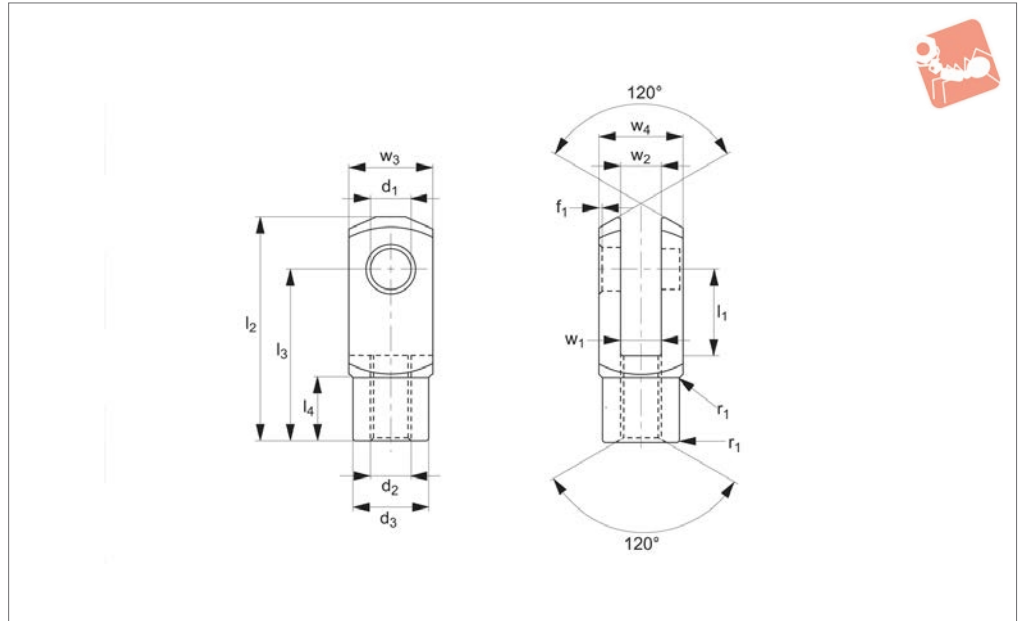

Material

Steel 1.0718 (11SMnPb30k), silver zinc plated.

Technical Notes

M4-M16: DIN 71 752/DIN ISO 8140.

M18-M48: Similar to DIN 71 752/DIN ISO 8140 and according to CETOP standard.

Tips

For yellow zinc plated version see R3393, standard thread is right hand, (for left

hand, see 65631).

Important Notes

For sizes M4-M12, f_1 and $r_1=0,5$, for sizes M14-M16, f_1 and $r_1=1$

For sizes M18-M20, $f_1=1$, $r_1=1,5$, for M24 f_1 and $r_1=1,5$, for sizes M27-M30, $f_1=1,5$, $r_1=2$

For M36 $f_1=2$, $r_1=3$, for sizes M42-M48, $f_1=3$, $r_1=5$, for r_1 , radius or 45° bevelling. Other Tolerances:-

w_4 : M4-M16 = +0,3 -0,16

M18-M48 = +0,5 -0,2

w_2 : size 4x8-10x20 = B13

All others +0,7 +0,15

d_3 : M4-M16 = ±0,3

l_2 : size 4x8-6x12 = ±0,3

All others ±0,4

l_3 : M4-M16 = ±0,2

M18-M48 = ±0,3

r_1 : M18-M48 = ±0,5

Order No.	Size	Thread hand	Thread type	d_1 tol. H9	l_1 ±0.5	d_2	d_3	l_2 ±0.5	l_3	l_4	w_1 tol. B13	w_2	w_3 tol. h11	w_4	Weight g
65630.W0040	4x8	Right	Coarse	4	8	M4	8	21	16	6.0	4	4	8	8	5
65630.W0041	4x16	Right	Coarse	4	16	M4	8	29	24	6.0	4	4	8	8	7
65630.W0051	5x10	Right	Coarse	5	10	M5	9	26	20	7.5	5	5	10	10	9
65630.W0052	5x20	Right	Coarse	5	20	M5	9	36	30	7.5	5	5	10	10	13
65630.W0061	6x12	Right	Coarse	6	12	M6	10	31	24	9.0	6	6	12	12	15
65630.W0062	6x24	Right	Coarse	6	24	M6	10	43	36	9.0	6	6	12	12	21
65630.W0081	8x16	Right	Coarse	8	16	M8	14	42	32	12.0	8	8	16	16	37
65630.W0082	8x16	Right	Fine	8	16	M8x1	14	42	32	12.0	8	8	16	16	37
65630.W0083	8x32	Right	Coarse	8	32	M8	14	58	48	12.0	8	8	16	16	54
65630.W0084	8x32	Right	Fine	8	32	M8x1	14	58	48	12.0	8	8	16	16	54
65630.W0102	10x20	Right	Coarse	10	20	M10	18	52	40	15.0	10	10	20	20	74
65630.W0103	10x20	Right	Fine	10	20	M10x1,25	18	52	40	15.0	10	10	20	20	74
65630.W0104	10x40	Right	Coarse	10	40	M10	18	72	60	15.0	10	10	20	20	116
65630.W0105	10x40	Right	Fine	10	40	M10x1,25	18	72	60	15.0	10	10	20	20	116
65630.W0122	12x24	Right	Coarse	12	24	M12	20	62	48	18.0	12	12	24	24	121
65630.W0123	12x24	Right	Fine	12	24	M12x1,25	20	62	48	18.0	12	12	24	24	121
65630.W0124	12x48	Right	Coarse	12	48	M12	20	86	72	18.0	12	12	24	24	175
65630.W0125	12x48	Right	Fine	12	48	M12x1,25	20	86	72	18.0	12	12	24	24	175
65630.W0142	14x28	Right	Coarse	14	28	M14	24	72	56	22.5	14	14	27	27	178
65630.W0143	14x28	Right	Fine	14	28	M14x1,5	24	72	56	22.5	14	14	27	27	178
65630.W0145	14x56	Right	Coarse	14	56	M14	24	101	85	22.5	14	14	27	27	258
65630.W0146	14x56	Right	Fine	14	56	M14x1,5	24	101	85	22.5	14	14	27	27	258
65630.W0163	16x32	Right	Coarse	16	32	M16	26	83	64	24.0	16	16	32	32	282
65630.W0164	16x32	Right	Fine	16	32	M16x1,5	26	83	64	24.0	16	16	32	32	282
65630.W0166	16x64	Right	Coarse	16	64	M16	26	115	96	24.0	16	16	32	32	411
65630.W0167	16x64	Right	Fine	16	64	M16x1,5	26	115	96	24.0	16	16	32	32	411



Steel Clevis Joints

silver zinc plated

Clevis Joints



Order No.	Size	Thread hand	Thread type	d ₁ tol. H9	l ₁ ±0.5	d ₂	d ₃	l ₂ ±0.5	l ₃	l ₄	w ₁ tol. B13	w ₂	w ₃ tol. h11	w ₄	Weight g
65630.W0183	18x36	Right	Coarse	18	36	M18	30	94	72	27.0	18	18	36	36	390
65630.W0184	18x36	Right	Fine	18	36	M18x1,5	30	94	72	27.0	18	18	36	36	390
65630.W0204	20x40	Right	Coarse	20	40	M20	34	105	80	30.0	20	20	40	40	550
65630.W0205	20x40	Right	Fine	20	40	M20x1,5	34	105	80	30.0	20	20	40	40	550
65630.W0208	20x80	Right	Coarse	20	80	M20	34	145	120	30.0	20	20	40	40	800
65630.W0209	20x80	Right	Fine	20	80	M20x1,5	34	145	120	30.0	20	20	40	40	800
65630.W0255	25x50	Right	Coarse	25	50	M24	42	132	100	36.0	25	25	50	50	1100
65630.W0256	25x50	Right	Fine	25	50	M24x2	42	132	100	36.0	25	25	50	50	1100
65630.W0285	28x56	Right	Coarse	28	56	M27	48	148	112	40.0	28	28	55	55	1500
65630.W0286	28x56	Right	Fine	28	56	M27x2	48	148	112	40.0	28	28	55	55	1500
65630.W0305	30x54	Right	Fine	30	54	M27x2	48	148	110	40.0	30	30	55	55	1440
65630.W0306	30x60	Right	Coarse	30	60	M30	52	160	120	42.0	30	30	60	60	1970
65630.W0307	30x60	Right	Fine	30	60	M30x2	52	160	120	42.0	30	30	60	60	1970
65630.W0355	35x54	Right	Fine	35	54	M36x2	60	188	144	54.0	35	35	70	70	2930
65630.W0357	35x72	Right	Coarse	35	72	M36	60	188	144	54.0	35	35	70	70	2930
65630.W0358	35x72	Right	Fine	35	72	M36x2	60	188	144	54.0	35	35	70	70	2930
65630.W0367	36x72	Right	Coarse	35	72	M36	60	188	144	54.0	36	36	70	70	2930
65630.W0368	36x72	Right	Fine	35	72	M36x2	60	188	144	54.0	36	36	70	70	2930
65630.W0408	40x84	Right	Fine	40	84	M42x2	70	232	168	63.5	40	40	85	85	5640
65630.W0428	42x84	Right	Coarse	42	84	M42	70	232	168	63.5	42	42	85	85	5340
65630.W0429	42x84	Right	Fine	42	84	M42x2	70	232	168	63.5	42	42	85	85	5340
65630.W0509	50x96	Right	Coarse	50	96	M48	82	265	192	73.0	50	50	96	96	7860
65630.W0510	50x96	Right	Fine	50	96	M48x2	82	265	192	73.0	50	50	96	96	7860

CLEVIS JOINTS



65631

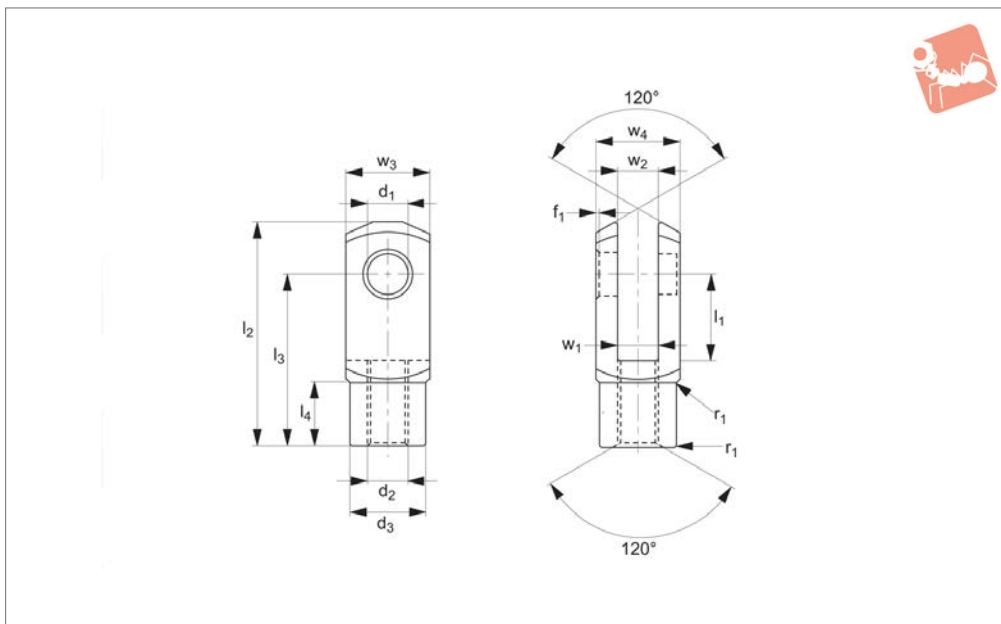

Material

Steel 1.0718 (11SMnPb30k), silver zinc plated.

Technical Notes

M4-M16: DIN 71 752/DIN ISO 8140.

M18-M48: Similar to DIN 71 752/DIN ISO 8140 and according to CETOP standard.

Tips

For yellow zinc plated version see R3394.

Important Notes

For sizes M4-M12, f_1 and $r_1=0,5$, for sizes M14-M16, f_1 and $r_1=1$

For sizes M18-M20, $f_1=1$, $r_1=1,5$, for M24 f_1 and $r_1=1,5$, for sizes M27-M30, $f_1=1,5$, $r_1=2$

For M36 $f_1=2$, $r_1=3$, for sizes M42-M48, $f_1=3$, $r_1=5$, for r_1 , radius or 45° bevelling.

Other Tolerances:-

w_4 : M4-M16 = +0,3 -0,16

M18-M48 = +0,5 -0,2

w_2 : size 4x8-10x20 = B13

All others +0,7 +0,15

d_3 : M4-M16 = ±0,3

l_2 : size 4x8-6x12 = ±0,3

All others ±0,4

l_3 : M4-M16 = ±0,2

M18-M48 = ±0,3

r_1 : M18-M48 = ±0,5

Order No.	Size	Thread hand	Thread type	d_1 tol. H9	l_1 ±0.5	d_2	d_3	l_2 ±0.5	l_3	l_4	w_1 tol. B13	w_2	w_3 tol. h11	w_4	Weight g
65631.W0040	4x8	Left	Coarse	4	8	M4	8	21	16	6.0	4	4	8	8	5
65631.W0041	4x16	Left	Coarse	4	16	M4	8	29	24	6.0	4	4	8	8	7
65631.W0051	5x10	Left	Coarse	5	10	M5	9	26	20	7.5	5	5	10	10	9
65631.W0052	5x20	Left	Coarse	5	20	M5	9	36	30	7.5	5	5	10	10	13
65631.W0061	6x12	Left	Coarse	6	12	M6	10	31	24	9.0	6	6	12	12	15
65631.W0062	6x24	Left	Coarse	6	24	M6	10	43	36	9.0	6	6	12	12	21
65631.W0081	8x16	Left	Coarse	8	16	M8	14	42	32	12.0	8	8	16	16	37
65631.W0082	8x16	Left	Fine	8	16	M8x1	14	42	32	12.0	8	8	16	16	37
65631.W0083	8x32	Left	Coarse	8	32	M8	14	58	48	12.0	8	8	16	16	54
65631.W0084	8x32	Left	Fine	8	32	M8x1	14	58	48	12.0	8	8	16	16	54
65631.W0102	10x20	Left	Coarse	10	20	M10	18	52	40	15.0	10	10	20	20	74
65631.W0103	10x20	Left	Fine	10	20	M10x1,25	18	52	40	15.0	10	10	20	20	74
65631.W0104	10x40	Left	Coarse	10	40	M10	18	72	60	15.0	10	10	20	20	116
65631.W0105	10x40	Left	Fine	10	40	M10x1,25	18	72	60	15.0	10	10	20	20	116
65631.W0122	12x24	Left	Coarse	12	24	M12	20	62	48	18.0	12	12	24	24	121
65631.W0123	12x24	Left	Fine	12	24	M12x1,25	20	62	48	18.0	12	12	24	24	121
65631.W0124	12x48	Left	Coarse	12	48	M12	20	86	72	18.0	12	12	24	24	175
65631.W0125	12x48	Left	Fine	12	48	M12x1,25	20	86	72	18.0	12	12	24	24	175
65631.W0142	14x28	Left	Coarse	14	28	M14	24	72	56	22.5	14	14	27	27	178
65631.W0143	14x28	Left	Fine	14	28	M14x1,5	24	72	56	22.5	14	14	27	27	178
65631.W0145	14x56	Left	Coarse	14	56	M14	24	101	85	22.5	14	14	27	27	258
65631.W0146	14x56	Left	Fine	14	56	M14x1,5	24	101	85	22.5	14	14	27	27	258
65631.W0163	16x32	Left	Coarse	16	32	M16	26	83	64	24.0	16	16	32	32	282
65631.W0164	16x32	Left	Fine	16	32	M16x1,5	26	83	64	24.0	16	16	32	32	282
65631.W0166	16x64	Left	Coarse	16	64	M16	26	115	96	24.0	16	16	32	32	411
65631.W0167	16x64	Left	Fine	16	64	M16x1,5	26	115	96	24.0	16	16	32	32	411



Steel Clevis Joints

left hand - silver zinc plated



Clevis Joints

Order No.	Size	Thread hand	Thread type	d ₁ tol. H9	l ₁ ±0.5	d ₂	d ₃	l ₂ ±0.5	l ₃	l ₄	w ₁ tol. B13	w ₂	w ₃ tol. h11	w ₄	Weight g
65631.W0183	18x36	Left	Coarse	18	36	M18	30	94	72	27.0	18	18	36	36	390
65631.W0184	18x36	Left	Fine	18	36	M18x1,5	30	94	72	27.0	18	18	36	36	390
65631.W0204	20x40	Left	Coarse	20	40	M20	34	105	80	30.0	20	20	40	40	550
65631.W0205	20x40	Left	Fine	20	40	M20x1,5	34	105	80	30.0	20	20	40	40	550
65631.W0208	20x80	Left	Coarse	20	80	M20	34	145	120	30.0	20	20	40	40	800
65631.W0209	20x80	Left	Fine	20	80	M20x1,5	34	145	120	30.0	20	20	40	40	800
65631.W0255	25x50	Left	Coarse	25	50	M24	42	132	100	36.0	25	25	50	50	1100
65631.W0256	25x50	Left	Fine	25	50	M24x2	42	132	100	36.0	25	25	50	50	1100
65631.W0285	28x56	Left	Coarse	28	56	M27	48	148	112	40.0	28	28	55	55	1500
65631.W0286	28x56	Left	Fine	28	56	M27x2	48	148	112	40.0	28	28	55	55	1500
65631.W0305	30x54	Left	Fine	30	54	M27x2	48	148	110	40.0	30	30	55	55	1440
65631.W0306	30x60	Left	Coarse	30	60	M30	52	160	120	42.0	30	30	60	60	1970
65631.W0307	30x60	Left	Fine	30	60	M30x2	52	160	120	42.0	30	30	60	60	1970
65631.W0355	35x54	Left	Fine	35	54	M36x2	60	188	144	54.0	35	35	70	70	2930
65631.W0357	35x72	Left	Coarse	35	72	M36	60	188	144	54.0	35	35	70	70	2930
65631.W0358	35x72	Left	Fine	35	72	M36x2	60	188	144	54.0	35	35	70	70	2930
65631.W0367	36x72	Left	Coarse	35	72	M36	60	188	144	54.0	36	36	70	70	2930
65631.W0368	36x72	Left	Fine	35	72	M36x2	60	188	144	54.0	36	36	70	70	2930
65631.W0408	40x84	Left	Fine	40	84	M42x2	70	232	168	63.5	40	40	85	85	5640
65631.W0428	42x84	Left	Coarse	42	84	M42	70	232	168	63.5	42	42	85	85	5340
65631.W0429	42x84	Left	Fine	42	84	M42x2	70	232	168	63.5	42	42	85	85	5340
65631.W0509	50x96	Left	Coarse	50	96	M48	82	265	192	73.0	50	50	96	96	7860
65631.W0510	50x96	Left	Fine	50	96	M48x2	82	265	192	73.0	50	50	96	96	7860

CLEVIS JOINTS

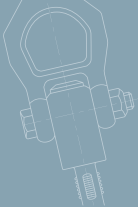

Parts overview

CLEVIS JOINTS

Clevis Joints

Stocked to DIN 71752 in steel and stainless steel. Plain clevis joints available in right and left hand threads zinc plated steel and stainless steel. Steel sizes from M4 up to M48. Stainless sizes from M4 up to M27.



Clevis Mating Pieces

These are designed to fit in between our clevis joints to create a linkage where an angular offset is required. Available in zinc plated steel and stainless steel. Sizes M4 up to M20.



Clevis Pins and Clips

Various styles of pins and clips to suit clevis joints in zinc plated steel and stainless steel. Sizes available to suit all sizes of clevis joints that we offer.



Clevis Retention Clips

These are the most popular type of clip used with our clevis joints. They create a neat compact assembly, only available in zinc plated steel. Size available for clevis joints from 4mm up to 20mm.



Male Clevis Joints

Stocked in zinc plated steel and stainless steel, right and left hand threads. Sizes M6 up to M20.





Clevis with retention clip
65630 and 65684



Clevis with clevis pin, washer and cotter pin
65660 and 65674



Zinc plated steel

Clevis with clevis pin 65664
Safety fastener 65680

Clevis with clevis pin and circlips 65666 and 65678



Clevis with clevis pin, washer and cotter pin 65661 and 65675



Stainless steel

Clevis with 65652 mating piece and 65684 clevis retention clip



Clevis with 65880 rod end and 65684 clevis retention clip



Assembly options

Tensile tests, statistically to failure (break)

Clevis joints axially loaded.

Leaded low carbon steel (AISI 12L14, 1.0718).

Clevises M6 - M42

Material

Clevis size	F min (kN)	F max (kN)	F average value (kN)	Avg. force when clevis starts to deform (kN)
6 x 24 M 6	16,0	19,5	17,6	15,3
8 x 32 M 8	33,2	35,6	34,6	29,3
10 x 40 M10	42,0	52,0	47,5	41,3
12 x 48 M12	53,0	68,5	61,1	50,2
14 x 56 M14	60,5	64,5	63,0	48,8
16 x 64 M16	133,5	146,0	140,2	115
20 x 40 M20	194,5	234,0	213,5	176
25 x 50 M25	311,0	336,0	328,0	260
30 x 60 M30	428,0	450,0	440,6	343
36 x 72 M36	566,0	573,0	569,5	300
35 x 72 M36	561,2	567,9	564,6	370
42 x 84 M42	904,6	904,6	904,6	420

Important note: values in this table are indicative only and should only be used as a rough guide. The Company cannot foresee the intended applications of their products and we accept no liability for any actions taken by third parties. Customers are advised to use their own safety factors and/or perform their own testing on the clevis joint to ensure it meets requirements for their application.



65610

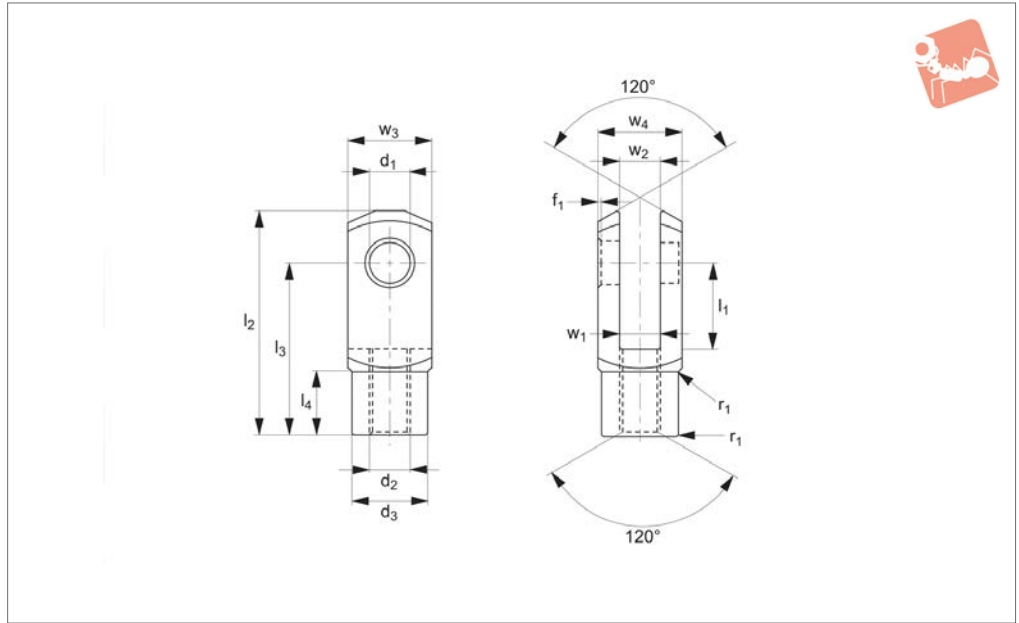

Material

Stainless steel (1.4305 AISI 303 X8CrNiS18-9)

Technical Notes

M5-M16: DIN 71 752/DIN ISO 8140.

M20-M24: Similar to DIN 71 752 and according to CETOP standard.

Tips

Standard thread is right hand (for left

hand, see 65612).

Assembly is made up using 65635 clevis joint, 65661 pin, P0330 washer, and 65675 split cotter pin.

Important Notes

For sizes M5-M12, f_1 and $r_1 = 0,5$, for sizes M14-M16, f_1 and $r_1 = 1$

For size M20, $f_1=1, r_1 = 1,5$, for M24, f_1 and

$r_1 = 1,5$, for r_1 , radius or 45° bevelling.

Other Tolerances:-

w_4 : M4-M16 = +0,3 -0,16

M20-M24 = +0,5 - 0,2

w_2 : Size 4x8-10x20 = B13

Size 10x40-25x50 = +0,7 +0,15

l_3 : up to size 6x12 = ±0,3

From size 6x24 = ±0,4

Order No.	Size	Thread hand	Thread type	d_1 tol. H9	l_1 ±0.5	d_2	d_3	l_2 ±0.5	l_3	l_4	w_1 ±0.5	w_2	w_3 tol. h11	w_4	Weight g
65610.W0051	5x10	Right	Coarse	5	10	M5	9	26	20	7.5	5	5	10	10	9
65610.W0052	5x20	Right	Coarse	5	20	M5	9	36	30	7.5	5	5	10	10	13
65610.W0061	6x12	Right	Coarse	6	12	M6	10	31	24	9.0	6	6	12	12	15
65610.W0062	6x24	Right	Coarse	6	24	M6	10	43	36	9.0	6	6	12	12	21
65610.W0081	8x16	Right	Coarse	8	16	M8	14	42	32	12.0	8	8	16	16	37
65610.W0082	8x16	Right	Fine	8	16	M8x1	14	42	32	12.0	8	8	16	16	37
65610.W0083	8x32	Right	Coarse	8	32	M8	14	58	48	12.0	8	8	16	16	54
65610.W0084	8x32	Right	Fine	8	32	M8x1	14	58	48	12.0	8	8	16	16	54
65610.W0102	10x20	Right	Coarse	10	20	M10	18	52	40	15.0	10	10	20	20	74
65610.W0103	10x20	Right	Fine	10	20	M10x1,25	18	52	40	15.0	10	10	20	20	74
65610.W0104	10x40	Right	Coarse	10	40	M10	18	72	60	15.0	10	10	20	20	116
65610.W0105	10x40	Right	Fine	10	40	M10x1,25	18	72	60	15.0	10	10	20	20	116
65610.W0122	12x24	Right	Coarse	12	24	M12	20	62	48	18.0	12	12	24	24	121
65610.W0123	12x24	Right	Fine	12	24	M12x1,25	20	62	48	18.0	12	12	24	24	121
65610.W0124	12x48	Right	Coarse	12	48	M12	20	86	72	18.0	12	12	24	24	175
65610.W0125	12x48	Right	Fine	12	48	M12x1,25	20	86	72	18.0	12	12	24	24	175
65610.W0142	14x28	Right	Coarse	14	28	M14	24	72	56	22.5	14	14	27	27	178
65610.W0143	14x28	Right	Fine	14	28	M14x1,5	24	72	56	22.5	14	14	27	27	178
65610.W0145	14x56	Right	Coarse	14	56	M14	24	101	85	22.5	14	14	27	27	258
65610.W0146	14x56	Right	Fine	14	56	M14x1,5	24	101	85	22.5	14	14	27	27	258
65610.W0163	16x32	Right	Coarse	16	32	M16	26	83	64	24.0	16	16	32	32	282
65610.W0164	16x32	Right	Fine	16	32	M16x1,5	26	83	64	24.0	16	16	32	32	282
65610.W0166	16x64	Right	Coarse	16	64	M16	26	115	96	24.0	16	16	32	32	411
65610.W0167	16x64	Right	Fine	16	64	M16x1,5	26	115	96	24.0	16	16	32	32	411
65610.W0204	20x40	Right	Coarse	20	40	M20	34	105	80	30.0	20	20	40	40	550
65610.W0205	20x40	Right	Fine	20	40	M20x1,5	34	105	80	30.0	20	20	40	40	550
65610.W0255	25x50	Right	Coarse	25	50	M24	42	132	100	36.0	25	25	50	50	1100



Stainless Clevis Joint with Pin

Clevis Joints



Order No.	Size	Thread hand	Thread type	d_1 tol. H9	l_1 ± 0.5	d_2	d_3	l_2 ± 0.5	l_3	l_4	w_1 ± 0.5	w_2	w_3 tol. h11	w_4	Weight g
65610.W0256	25x50	Right	Fine	25	50	M24x2	42	132	100	36.0	25	25	50	50	1100

CLEVIS JOINTS



65612

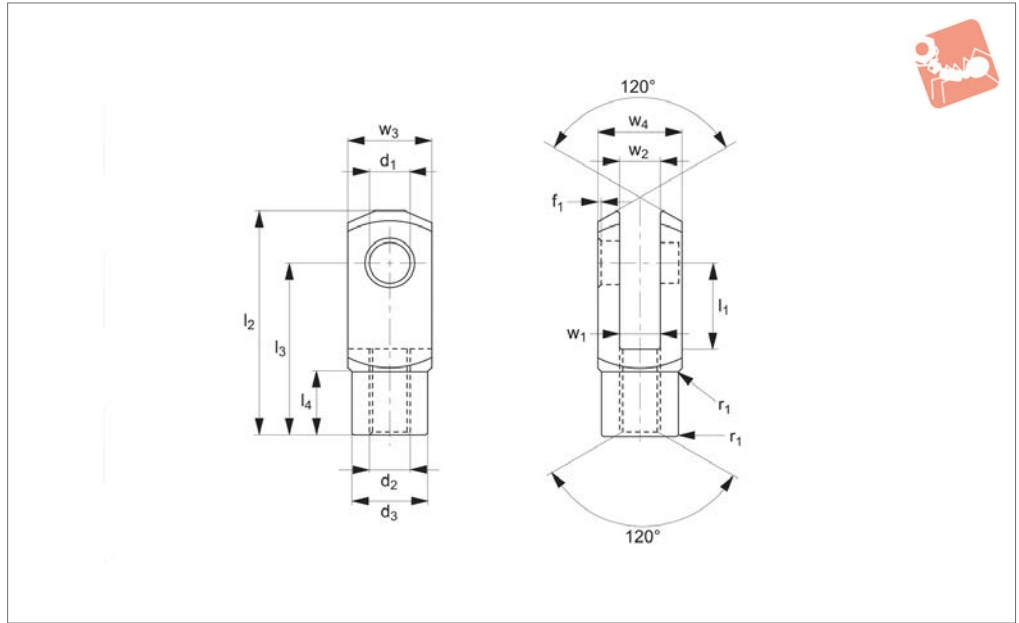

Material

Stainless steel (1.4305 AISI 303 X8CrNiS18-9)

Technical Notes

M5-M16: DIN 71 752/DIN ISO 8140.

M20-M24: Similar to DIN 71 752 and according to CETOP standard.

Tips

Assembly is made up using 65636 clevis

joint, 65661 pin, P0330 washer, and 65675 split cotter pin.

Important Notes

For sizes M5-M12, f_1 and $r_1 = 0,5$, for sizes M14-M16, f_1 and $r_1 = 1$

For size M20, $f_1=1$, $r_1 = 1,5$, for M24, f_1 and $r_1 = 1,5$, for r_1 , radius or 45° bevelling.

Other Tolerances:-

w_4 : M4-M16 = +0,3 -0,16

M20-M27 = +0,5 - 0,2

w_2 : Size 4x8-10x20 = B13

Size 10x40-30x54 = +0,7 +0,15

l_3 : up to size 6x12 = ±0,3

From size 6x24 = ±0,4

Order No.	Size	Thread hand	Thread type	d_1 tol. H9	l_1 ±0.5	d_2	d_3	l_2 ±0.5	l_3	l_4	w_1 tol. B13	w_2	w_3 tol. h11	w_4	Weight g
65612.W0051	5x10	Left	Coarse	5	10	M5	9	26	20	7.5	5	5	10	10	9
65612.W0052	5x20	Left	Coarse	5	20	M5	9	36	30	7.5	5	5	10	10	13
65612.W0061	6x12	Left	Coarse	6	12	M6	10	31	24	9.0	6	6	12	12	15
65612.W0062	6x24	Left	Coarse	6	24	M6	10	43	36	9.0	6	6	12	12	21
65612.W0081	8x16	Left	Coarse	8	16	M8	14	42	32	12.0	8	8	16	16	37
65612.W0082	8x16	Left	Fine	8	16	M8x1	14	42	32	12.0	8	8	16	16	37
65612.W0083	8x32	Left	Coarse	8	32	M8	14	58	48	12.0	8	8	16	16	54
65612.W0084	8x32	Left	Fine	8	32	M8x1	14	58	48	12.0	8	8	16	16	54
65612.W0102	10x20	Left	Coarse	10	20	M10	18	52	40	15.0	10	10	20	20	74
65612.W0103	10x20	Left	Fine	10	20	M10x1,25	18	52	40	15.0	10	10	20	20	74
65612.W0104	10x40	Left	Coarse	10	40	M10	18	72	60	15.0	10	10	20	20	116
65612.W0105	10x40	Left	Fine	10	40	M10x1,25	18	72	60	15.0	10	10	20	20	116
65612.W0122	12x24	Left	Coarse	12	24	M12	20	62	48	18.0	12	12	24	24	121
65612.W0123	12x24	Left	Fine	12	24	M12x1,25	20	62	48	18.0	12	12	24	24	121
65612.W0124	12x48	Left	Coarse	12	48	M12	20	86	72	18.0	12	12	24	24	175
65612.W0125	12x48	Left	Fine	12	48	M12x1,25	20	86	72	18.0	12	12	24	24	175
65612.W0142	14x28	Left	Coarse	14	28	M14	24	72	56	22.5	14	14	27	27	178
65612.W0143	14x28	Left	Fine	14	28	M14x1,5	24	72	56	22.5	14	14	27	27	178
65612.W0145	14x56	Left	Coarse	14	56	M14	24	101	85	22.5	14	14	27	27	258
65612.W0146	14x56	Left	Fine	14	56	M14x1,5	24	101	85	22.5	14	14	27	27	258
65612.W0163	16x32	Left	Coarse	16	32	M16	26	83	64	24.0	16	16	32	32	282
65612.W0164	16x32	Left	Fine	16	32	M16x1,5	26	83	64	24.0	16	16	32	32	282
65612.W0166	16x64	Left	Coarse	16	64	M16	26	115	96	24.0	16	16	32	32	411
65612.W0167	16x64	Left	Fine	16	64	M16x1,5	26	115	96	24.0	16	16	32	32	411
65612.W0204	20x40	Left	Coarse	20	40	M20	34	105	80	30.0	20	20	40	40	550
65612.W0205	20x40	Left	Fine	20	40	M20x1,5	34	105	80	30.0	20	20	40	40	550
65612.W0255	25x50	Left	Coarse	25	50	M24	42	132	100	36.0	25	25	50	50	1100



Stainless Clevis Joints with Pin

left hand thread

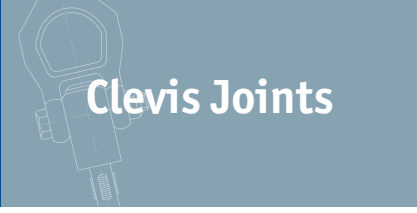

Clevis Joints

Order No.	Size	Thread hand	Thread type	d_1 tol. H9	l_1 ± 0.5	d_2	d_3	l_2 ± 0.5	l_3	l_4	w_1 tol. B13	w_2	w_3 tol. h11	w_4	Weight g
65612.W0256	25x50	Left	Fine	25	50	M24x2	42	132	100	36.0	25	25	50	50	1100

CLEVIS JOINTS



65614

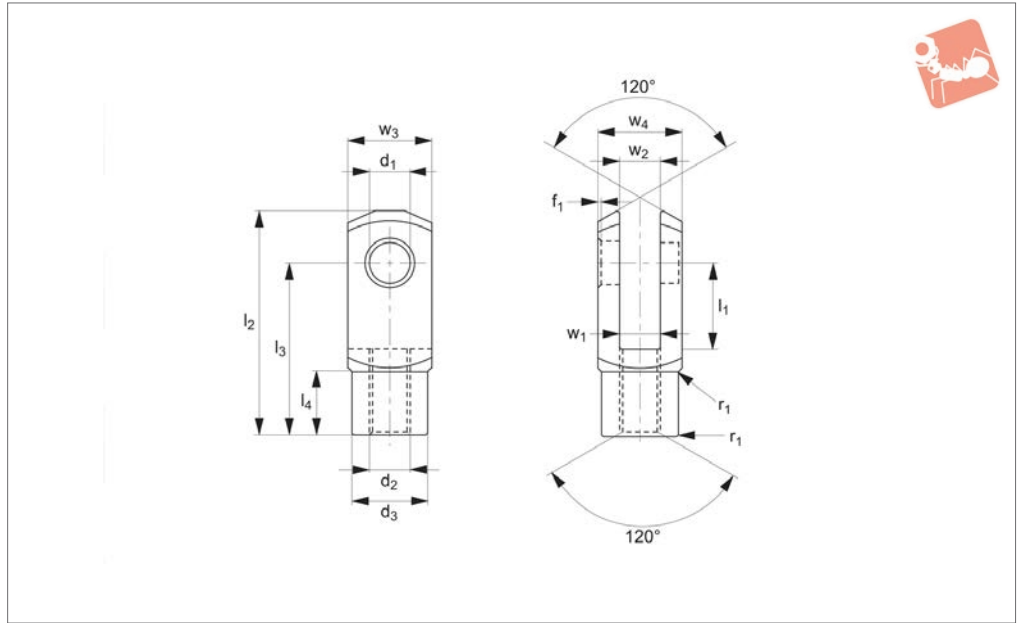

Material

Stainless steel (1.4305 AISI 303 X8CrNiS18-9)

Technical Notes

M5-M16: DIN 71 752/DIN ISO 8140.

M20: Similar to DIN 71 752 and according to CETOP standard.

Tips

Standard thread is right hand, (for left

hand, see 65616).

Assembly is made up using 65635 clevis joint, 65666 pin, and 2 off 65678 circlips.

Important Notes

For sizes M5-M12, f_1 and $r_1 = 0,5$, for sizes M16, f_1 and $r_1 = 1$

For size M20, $f_1=1$, $r_1 = 1,5$, for r_1 , radius or 45° bevelling.

Other Tolerances:-

w_4 : M4-M16 = +0,3 -0,16

M20 = +0,5 - 0,2

w_2 : Size 4x8-10x20 = B13

Size 10x40-20x40 = +0,7 +0,15

l_3 : up to size 6x12 = ±0,3

From size 6x24 = ±0,4

Order No.	Size	Thread hand	Thread type	d_1 tol. H9	l_1 ±0.5	d_2	d_3	l_2 ±0.5	l_3	l_4	w_1 ±0.5	w_2	w_3 tol. h11	w_4	Weight g
65614.W0051	5x10	Right	Coarse	5	10	M5	9	26	20	7.5	5	5	10	10	9
65614.W0052	5x20	Right	Coarse	5	20	M5	9	36	30	7.5	5	5	10	10	13
65614.W0061	6x12	Right	Coarse	6	12	M6	10	31	24	9.0	6	6	12	12	15
65614.W0062	6x24	Right	Coarse	6	24	M6	10	43	36	9.0	6	6	12	12	21
65614.W0081	8x16	Right	Coarse	8	16	M8	14	42	32	12.0	8	8	16	16	37
65614.W0082	8x16	Right	Fine	8	16	M8x1	14	42	32	12.0	8	8	16	16	37
65614.W0083	8x32	Right	Coarse	8	32	M8	14	58	48	12.0	8	8	16	16	54
65614.W0084	8x32	Right	Fine	8	32	M8x1	14	58	48	12.0	8	8	16	16	54
65614.W0102	10x20	Right	Coarse	10	20	M10	18	52	40	15.0	10	10	20	20	74
65614.W0103	10x20	Right	Fine	10	20	M10x1,25	18	52	40	15.0	10	10	20	20	74
65614.W0104	10x40	Right	Coarse	10	40	M10	18	72	60	15.0	10	10	20	20	116
65614.W0105	10x40	Right	Fine	10	40	M10x1,25	18	72	60	15.0	10	10	20	20	116
65614.W0122	12x24	Right	Coarse	12	24	M12	20	62	48	18.0	12	12	24	24	121
65614.W0123	12x24	Right	Fine	12	24	M12x1,25	20	62	48	18.0	12	12	24	24	121
65614.W0124	12x48	Right	Coarse	12	48	M12	20	86	72	18.0	12	12	24	24	175
65614.W0125	12x48	Right	Fine	12	48	M12x1,25	20	86	72	18.0	12	12	24	24	175
65614.W0163	16x32	Right	Coarse	16	32	M16	26	83	64	24.0	16	16	32	32	282
65614.W0164	16x32	Right	Fine	16	32	M16x1,5	26	83	64	24.0	16	16	32	32	282
65614.W0166	16x64	Right	Coarse	16	64	M16	26	115	96	24.0	16	16	32	32	411
65614.W0167	16x64	Right	Fine	16	64	M16x1,5	26	115	96	24.0	16	16	32	32	411
65614.W0204	20x40	Right	Coarse	20	40	M20	34	105	80	30.0	20	20	40	40	550
65614.W0205	20x40	Right	Fine	20	40	M20x1,5	34	105	80	30.0	20	20	40	40	550



Stainless Clevis Joints with Pin

left hand thread

Clevis Joints

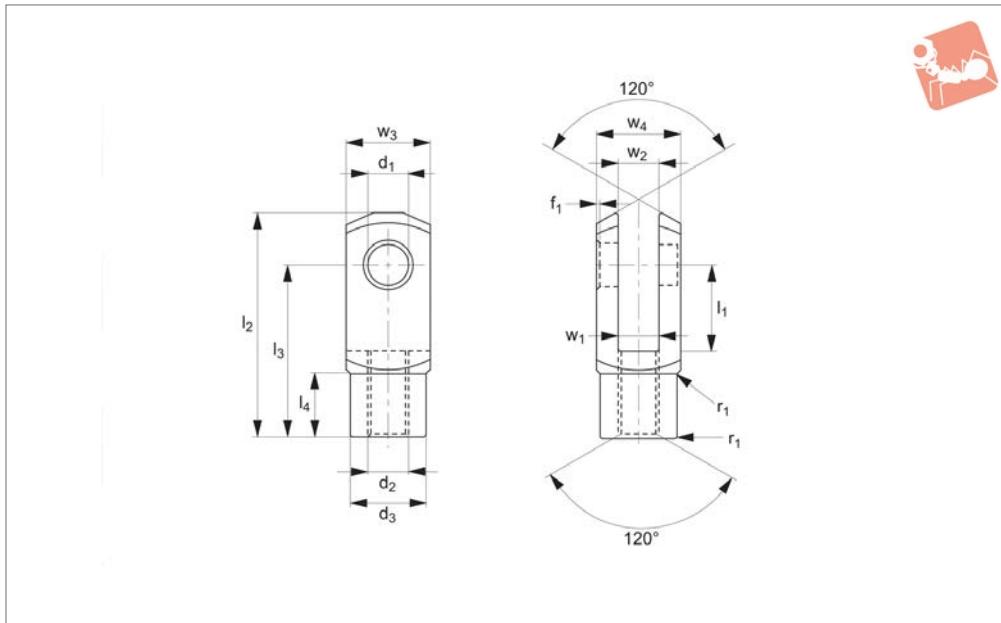

65616

CLEVIS JOINTS

Material

Stainless steel (1.4305 AISI 303 X8CrNiS18-9)

Technical Notes

M5-M16: DIN 71 752/DIN ISO 8140.
M20: Similar to DIN 71 752 and according to CETOP standard.

Tips

Assembly is made up using 65636 clevis

joint, 65666 pin, and 2 off 65678 circlips.

Important Notes

For sizes M5-M12, f_1 and $r_1 = 0,5$, for sizes M16, f_1 and $r_1 = 1$
For size M20, $f_1=1$, $r_1 = 1,5$, for r_1 , radius or 45° bevelling.
Other Tolerances:-
 w_4 : M4-M16 = +0,3 -0,16
M20 = +0,5 - 0,2

w_2 : Size 4x8-10x20 = B13
Size 10x40-20x40 = +0,7 +0,15
 l_3 : up to size 6x12 = ±0,3
From size 6x24 = ±0,4

Order No.	Size	Thread hand	Thread type	d_1 tol. H9	l_1 ±0.5	d_2	d_3	l_2 ±0.5	l_3	l_4	w_1 tol. B13	w_2	w_3 tol. h11	w_4	Weight g
65616.W0051	5x10	Left	Coarse	5	10	M5	9	26	20	7.5	5	5	10	10	9
65616.W0052	5x20	Left	Coarse	5	20	M5	9	36	30	7.5	5	5	10	10	13
65616.W0061	6x12	Left	Coarse	6	12	M6	10	31	24	9.0	6	6	12	12	15
65616.W0062	6x24	Left	Coarse	6	24	M6	10	43	36	9.0	6	6	12	12	21
65616.W0081	8x16	Left	Coarse	8	16	M8	14	42	32	12.0	8	8	16	16	37
65616.W0082	8x16	Left	Fine	8	16	M8x1	14	42	32	12.0	8	8	16	16	37
65616.W0083	8x32	Left	Coarse	8	32	M8	14	58	48	12.0	8	8	16	16	54
65616.W0084	8x32	Left	Fine	8	32	M8x1	14	58	48	12.0	8	8	16	16	54
65616.W0102	10x20	Left	Coarse	10	20	M10	18	52	40	15.0	10	10	20	20	74
65616.W0103	10x20	Left	Fine	10	20	M10x1,25	18	52	40	15.0	10	10	20	20	74
65616.W0104	10x40	Left	Coarse	10	40	M10	18	72	60	15.0	10	10	20	20	116
65616.W0105	10x40	Left	Fine	10	40	M10x1,25	18	72	60	15.0	10	10	20	20	116
65616.W0122	12x24	Left	Coarse	12	24	M12	20	62	48	18.0	12	12	24	24	121
65616.W0123	12x24	Left	Fine	12	24	M12x1,25	20	62	48	18.0	12	12	24	24	121
65616.W0124	12x48	Left	Coarse	12	48	M12	20	86	72	18.0	12	12	24	24	175
65616.W0125	12x48	Left	Fine	12	48	M12x1,25	20	86	72	18.0	12	12	24	24	175
65616.W0163	16x32	Left	Coarse	16	32	M16	26	83	64	24.0	16	16	32	32	282
65616.W0164	16x32	Left	Fine	16	32	M16x1,5	26	83	64	24.0	16	16	32	32	282
65616.W0166	16x64	Left	Coarse	16	64	M16	26	115	96	24.0	16	16	32	32	411
65616.W0167	16x64	Left	Fine	16	64	M16x1,5	26	115	96	24.0	16	16	32	32	411
65616.W0204	20x40	Left	Coarse	20	40	M20	34	105	80	30.0	20	20	40	40	550
65616.W0205	20x40	Left	Fine	20	40	M20x1,5	34	105	80	30.0	20	20	40	40	550



65635

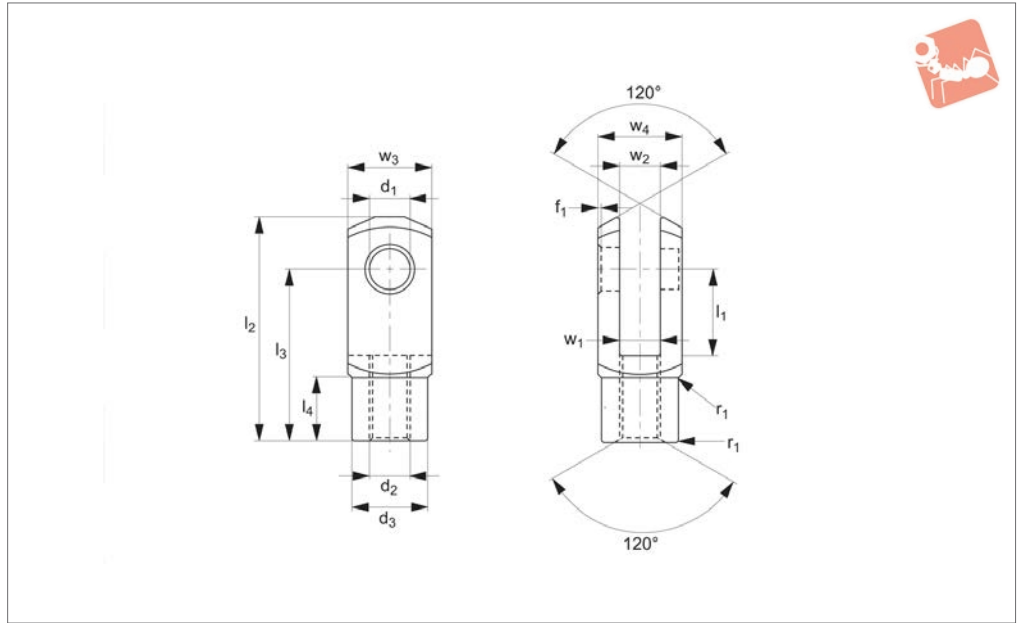

Material

Stainless steel (1.4305 AISI 303 X8CrNiS18-9).

Technical Notes

M4-M16: DIN 71 752/DIN ISO 8140.

M20-M27: Similar to DIN 71 752 and according to CETOP standard.

Tips

Standard thread is right hand, (for left

hand, see 65636).

Important Notes

For sizes M4-M12, f_1 and $r_1 = 0,5$, for sizes M14-M16, f_1 and $r_1 = 1$, for size M20, $f_1 = 1, r_1 = 1,5$

For M24, f_1 and $r_1 = 1,5$, for M27, $f_1 = 1,5, r_1 = 2$, for r_1 , radius or 45° bevelling.

Other Tolerances:-

w_4 : M4-M16 = $+0,3 -0,16$

M20-M27 = $+0,5 - 0,2$

w_2 : Size 4x8-10x20 = B13

Size 10x40-30x54 = $+0,7 +0,15$

l_3 : up to size 6x12 = $\pm 0,3$

From size 6x24 = $\pm 0,4$

Order No.	Size	Thread hand	Thread type	d_1 tol. h9	l_1 ± 0.5	d_2	d_3	l_2 ± 0.5	l_3	l_4	w_1 ± 0.5	w_2	w_3 tol. h11	w_4	Weight g
65635.W0040	4x8	Right	Coarse	4	8	M 4	8	21	16	6.0	4	4	8	8	5
65635.W0041	4x16	Right	Coarse	4	16	M 4	8	29	24	6.0	4	4	8	8	7
65635.W0051	5x10	Right	Coarse	5	10	M 5	9	26	20	7.5	5	5	10	10	9
65635.W0052	5x20	Right	Coarse	5	20	M 5	9	36	30	7.5	5	5	10	10	13
65635.W0061	6x12	Right	Coarse	6	12	M 6	10	31	24	9.0	6	6	12	12	15
65635.W0062	6x24	Right	Coarse	6	24	M 6	10	43	36	9.0	6	6	12	12	21
65635.W0081	8x16	Right	Coarse	8	16	M 8	14	42	32	12.0	8	8	16	16	37
65635.W0082	8x16	Right	Fine	8	16	M 8x1	14	42	32	12.0	8	8	16	16	37
65635.W0083	8x32	Right	Coarse	8	32	M 8	14	58	48	12.0	8	8	16	16	54
65635.W0084	8x32	Right	Fine	8	32	M 8x1	14	58	48	12.0	8	8	16	16	54
65635.W0102	10x20	Right	Coarse	10	20	M10	18	52	40	15.0	10	10	20	20	74
65635.W0103	10x20	Right	Fine	10	20	M10x1,25	18	52	40	15.0	10	10	20	20	74
65635.W0104	10x40	Right	Coarse	10	40	M10	18	72	60	15.0	10	10	20	20	116
65635.W0105	10x40	Right	Fine	10	40	M10x1,25	18	72	60	15.0	10	10	20	20	116
65635.W0122	12x24	Right	Coarse	12	24	M12	20	62	48	18.0	12	12	24	24	121
65635.W0123	12x24	Right	Fine	12	24	M12x1,25	20	62	48	18.0	12	12	24	24	121
65635.W0124	12x48	Right	Coarse	12	48	M12	20	86	72	18.0	12	12	24	24	175
65635.W0125	12x48	Right	Fine	12	48	M12x1,25	20	86	72	18.0	12	12	24	24	175
65635.W0142	14x28	Right	Coarse	14	28	M14	24	72	56	22.5	14	14	27	27	178
65635.W0143	14x28	Right	Fine	14	28	M14x1,5	24	72	56	22.5	14	14	27	27	178
65635.W0145	14x56	Right	Coarse	14	56	M14	24	101	85	22.5	14	14	27	27	258
65635.W0146	14x56	Right	Fine	14	56	M14x1,5	24	101	85	22.5	14	14	27	27	258
65635.W0163	16x32	Right	Coarse	16	32	M16	26	83	64	24.0	16	16	32	32	282
65635.W0164	16x32	Right	Fine	16	32	M16x1,5	26	83	64	24.0	16	16	32	32	282
65635.W0166	16x64	Right	Coarse	16	64	M16	26	115	96	24.0	16	16	32	32	411
65635.W0167	16x64	Right	Fine	16	64	M16x1,5	26	115	96	24.0	16	16	32	32	411
65635.W0204	20x40	Right	Coarse	20	40	M20	34	105	80	30.0	20	20	40	40	550



Stainless Clevis Joint

Clevis Joints



Order No.	Size	Thread hand	Thread type	d ₁ tol. h9	l ₁ ±0.5	d ₂	d ₃	l ₂ ±0.5	l ₃	l ₄	w ₁ ±0.5	w ₂	w ₃ tol. h11	w ₄	Weight g
65635.W0205	20x40	Right	Fine	20	40	M20x1,5	34	105	80	30.0	20	20	40	40	550
65635.W0255	25x50	Right	Coarse	25	50	M24	42	132	100	36.0	25	25	50	50	1100
65635.W0256	25x50	Right	Fine	25	50	M24x2	42	132	100	36.0	25	25	50	50	1100
65635.W0305	30x54	Right	Fine	30	54	M27x2	48	148	110	40.0	30	30	55	55	1440



65636

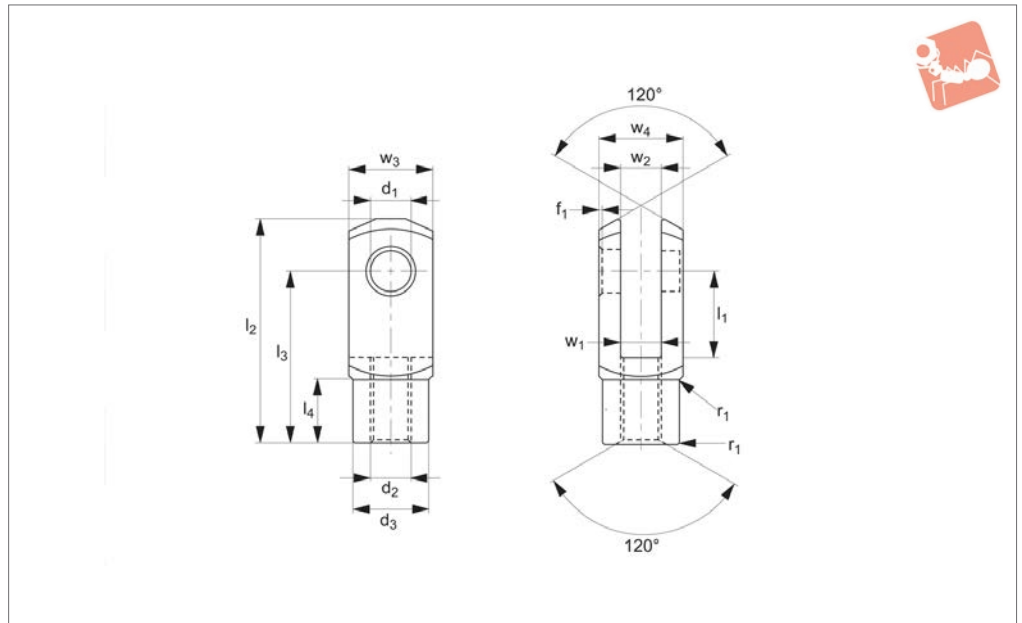

Material

Stainless steel (1.4305 AISI 303
X8CrNiS18-9)

Technical Notes

M4-M16: DIN 71 752/DIN ISO 8140.

M20-M27: Similar to DIN 71 752 and according to CETOP standard.

Important Notes

For sizes M4-M12, f_1 and $r_1 = 0,5$, for sizes M14-M16, f_1 and $r_1 = 1$, for size M20, $f_1 = 1$, $r_1 = 1,5$

For M24, f_1 and $r_1 = 1,5$, for M27, $f_1 = 1,5$, $r_1 = 2$, for r_1 , radius or 45° bevelling.

Other Tolerances:-

w_4 : M4-M16 = +0,3 -0,16

M20-M27 = +0,5 - 0,2

w_2 : Size 4x8-10x20 = B13

Size 10x40-30x54 = +0,7 +0,15

l_3 : up to size 6x12 = ±0,3

From size 6x24 = ±0,4

Order No.	Size	Thread hand	Thread type	d_1 tol. H9	l_1 ±0.5	d_2	d_3	l_2 ±0.5	l_3	l_4	w_1 tol. B13	w_2	w_3 tol. h11	w_4	Weight g
65636.W0040	4x8	Left	Coarse	4	8	M4	8	21	16	6.0	4	4	8	8	5
65636.W0041	4x16	Left	Coarse	4	16	M4	8	29	24	6.0	4	4	8	8	7
65636.W0051	5x10	Left	Coarse	5	10	M5	9	26	20	7.5	5	5	10	10	9
65636.W0052	5x20	Left	Coarse	5	20	M5	9	36	30	7.5	5	5	10	10	13
65636.W0061	6x12	Left	Coarse	6	12	M6	10	31	24	9.0	6	6	12	12	15
65636.W0062	6x24	Left	Coarse	6	24	M6	10	43	36	9.0	6	6	12	12	21
65636.W0081	8x16	Left	Coarse	8	16	M8	14	42	32	12.0	8	8	16	16	37
65636.W0082	8x16	Left	Fine	8	16	M8x1	14	42	32	12.0	8	8	16	16	37
65636.W0083	8x32	Left	Coarse	8	32	M8	14	58	48	12.0	8	8	16	16	54
65636.W0102	10x20	Left	Coarse	10	20	M10	18	52	40	15.0	10	10	20	20	74
65636.W0103	10x20	Left	Fine	10	20	M10x1,25	18	52	40	15.0	10	10	20	20	74
65636.W0104	10x40	Left	Coarse	10	40	M10	18	72	60	15.0	10	10	20	20	116
65636.W0105	10x40	Left	Fine	10	40	M10x1,25	18	72	60	15.0	10	10	20	20	116
65636.W0122	12x24	Left	Coarse	12	24	M12	20	62	48	18.0	12	12	24	24	121
65636.W0123	12x24	Left	Fine	12	24	M12x1,25	20	62	48	18.0	12	12	24	24	121
65636.W0124	12x48	Left	Coarse	12	48	M12	20	86	72	18.0	12	12	24	24	175
65636.W0125	12x48	Left	Fine	12	48	M12x1,25	20	86	72	18.0	12	12	24	24	175
65636.W0142	14x28	Left	Coarse	14	28	M14	24	72	56	22.5	14	14	27	27	178
65636.W0143	14x28	Left	Fine	14	28	M14x1,5	24	72	56	22.5	14	14	27	27	178
65636.W0145	14x56	Left	Coarse	14	56	M14	24	101	85	22.5	14	14	27	27	258
65636.W0146	14x56	Left	Fine	14	56	M14x1,5	24	101	85	22.5	14	4	27	27	258
65636.W0163	16x32	Left	Coarse	16	32	M16	26	83	64	24.0	16	16	32	32	282
65636.W0164	16x32	Left	Fine	16	32	M16x1,5	26	83	64	24.0	16	16	32	32	282
65636.W0166	16x64	Left	Coarse	16	64	M16	26	115	96	24.0	16	16	32	32	411
65636.W0167	16x64	Left	Fine	16	64	M16x1,5	26	115	96	24.0	16	16	32	32	411
65636.W0204	20x40	Left	Coarse	20	40	M20	34	105	80	30.0	20	20	40	40	550
65636.W0205	20x40	Left	Fine	20	40	M20x1,5	34	105	80	30.0	20	20	40	40	550
65636.W0255	25x50	Left	Coarse	25	50	M24	42	132	100	36.0	25	25	50	50	1100
65636.W0256	25x50	Left	Fine	25	50	M24x2	42	132	100	36.0	25	25	50	50	1100
65636.W0305	30x54	Left	Fine	30	54	M27x2	48	148	110	40.0	30	30	55	55	1440

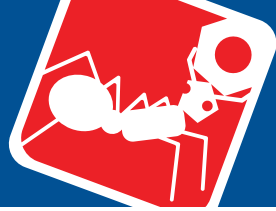

Male Clevis Joints

silver zinc plated

Clevis Joints

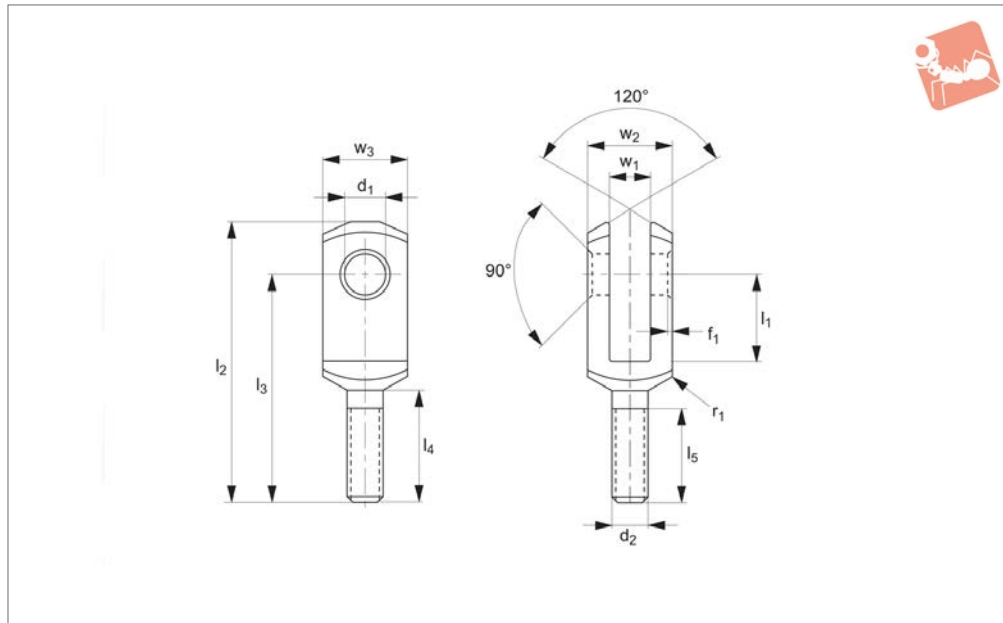

65640

CLEVIS JOINTS

Material

Steel (1.0718) silver zinc plated.

standard.

Other Tolerances: for r_1 , radius or 45° beveling.

Technical Notes

Similar to DIN 71 752/DIN ISO 8140/CETOP

Tips

Standard thread is right hand, (for left hand, see 65641).

Order No.	Size	Thread hand	d_1 tol. H9	l_1 ± 0.5	d_2	l_2 ± 0.2	l_3 ± 0.4	l_4 ± 0.2	l_5	w_1 $+0.7 +0.15$	w_2 $+0.5 +0.2$	w_3 tol. h11	f_1 ± 0.2	r_1	Weight g
65640.W0006	6x12	Right	6	12	M6	44	37	20	15	6	12	12	0.5	0.8	15
65640.W0008	8x16	Right	8	16	M8	57	47	25	20	8	16	16	0.5	0.8	36
65640.W0010	10x20	Right	10	20	M10	69	57	30	25	10	20	20	0.5	0.8	68
65640.W0012	12x24	Right	12	24	M12	82	68	35	30	12	24	24	0.5	0.8	112
65640.W0014	14x28	Right	14	28	M14	94	78	40	35	14	27	27	1.0	1.2	171
65640.W0016	16x32	Right	16	32	M16	108	89	45	40	16	32	32	1.0	1.2	288
65640.W0020	20x40	Right	20	40	M20	134	109	55	50	20	40	40	1.0	1.5	550



CLEVIS JOINTS



65641

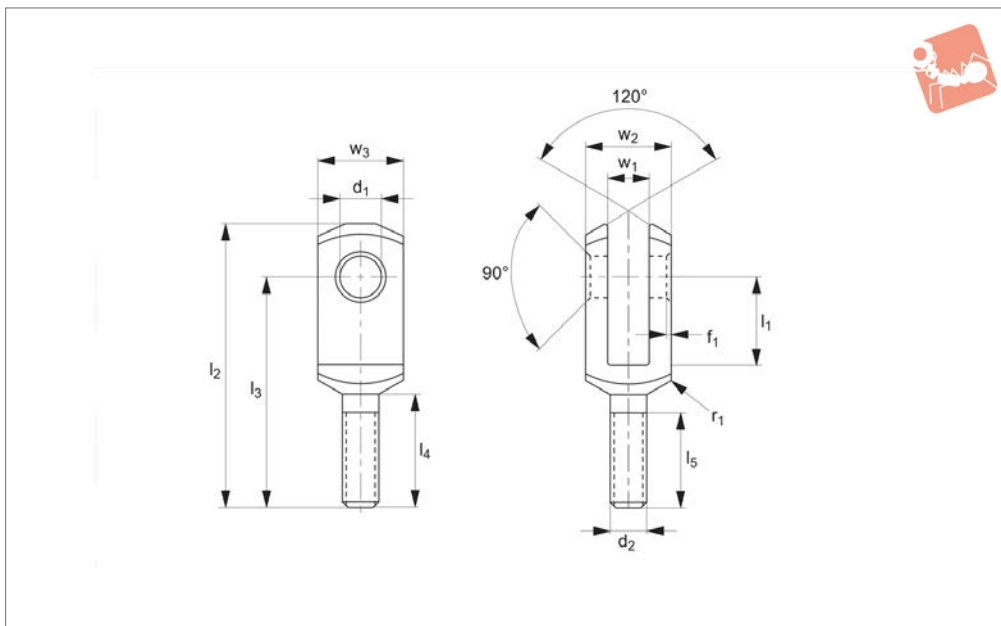

Material

Steel (1.0718) silver zinc plated.

standard.

Other Tolerances: for r_1 , radius or 45° bevelling.

Technical Notes

Similar to DIN 71 752/DIN ISO 8140/CETOP

Tips

Standard thread is right hand, (for left hand, see 65641).

Order No.	Size	Thread hand	d_1 tol. H9	l_1 ± 0.5	d_2	l_2 ± 0.2	l_3 ± 0.4	l_4 ± 0.2	l_5	w_1 $+0.7 -0.15$	w_2 $+0.5 +0.2$	w_3 tol. h11	f_1 ± 0.2	r_1	Weight g
65641.W0006	6x12	Left	6	12	M6	44	37	20	15	6	12	12	0.5	0.8	15
65641.W0008	8x16	Left	8	16	M8	57	47	25	20	8	16	16	0.5	0.8	36
65641.W0010	10x20	Left	10	20	M10	69	57	30	25	10	20	20	0.5	0.8	68
65641.W0012	12x24	Left	12	24	M12	82	68	35	30	12	24	24	0.5	0.8	112
65641.W0014	14x28	Left	14	28	M14	94	78	40	35	14	27	27	1.0	1.2	171
65641.W0016	16x32	Left	16	32	M16	108	89	45	40	16	32	32	1.0	1.2	288
65641.W0020	20x40	Left	20	40	M20	134	109	55	50	20	40	40	1.0	1.5	550

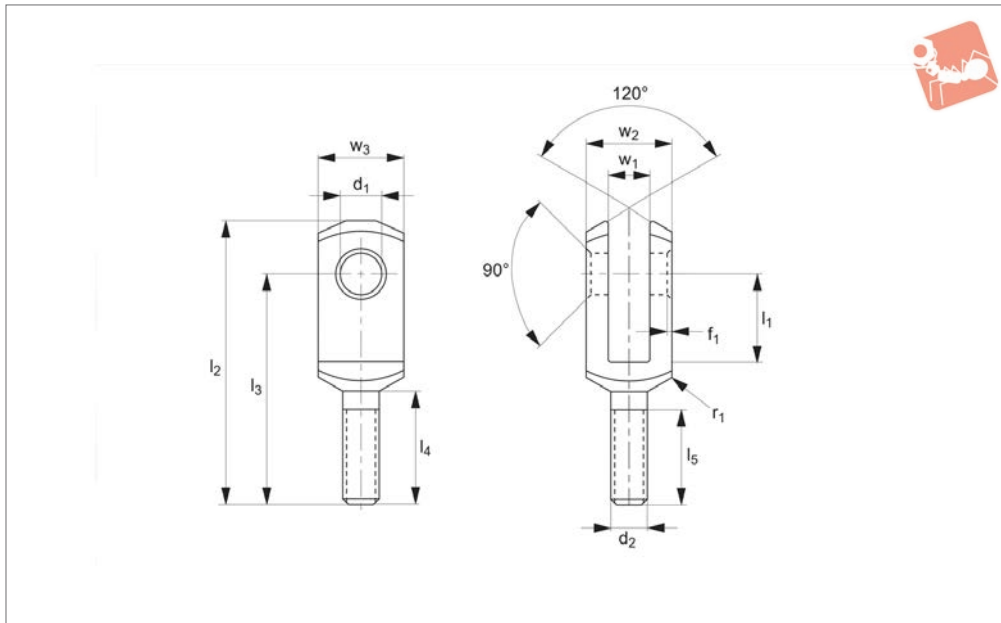

65645

CLEVIS JOINTS

Material

Stainless steel (1,4305 AISI 303).

standard.

Other Tolerances: For r_1 , radius or 45° bevelling.

Technical Notes

Similar to DIN 71 752/DIN ISO 8140/CETOP

Tips

Standard is right hand thread, (For left hand see 65646).

Order No.	Size	Thread hand	d_1 tol. H9	l_1 ± 0.5	d_2	l_2 ± 0.2	l_3 ± 0.4	l_4 ± 0.2	l_5	w_1 $+0.7 -0.15$	w_2 $+0.5 +0.2$	w_3 tol. h11	f_1 ± 0.2	r_1	Weight g
65645.W0006	6x12	Right	6	12	M 6	44	37	20	15	6	12	12	0.5	0.8	15
65645.W0008	8x16	Right	8	16	M 8	57	47	25	20	8	16	16	0.5	0.8	36
65645.W0010	10x20	Right	10	20	M10	69	57	30	25	10	20	20	0.5	0.8	68
65645.W0012	12x24	Right	12	24	M12	82	68	35	30	12	24	24	0.5	0.8	112
65645.W0014	14x28	Right	14	28	M14	94	78	40	35	14	27	27	1.0	1.2	171
65645.W0016	16x32	Right	16	32	M16	108	89	45	40	16	32	32	1.0	1.2	288
65645.W0020	20x40	Right	20	40	M20	134	109	55	50	20	40	40	1.0	1.5	550



CLEVIS JOINTS



65646

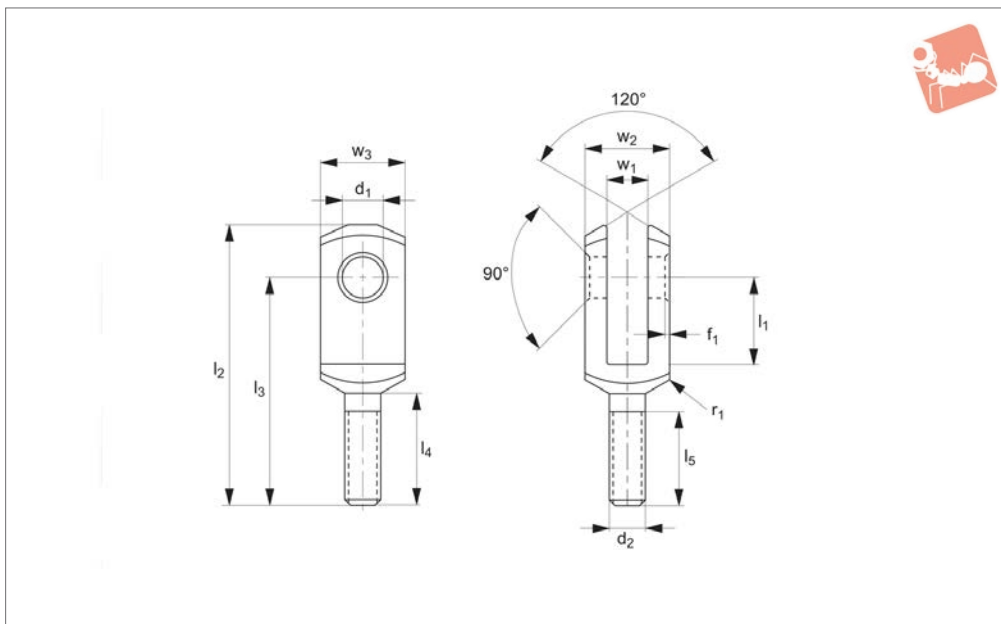

Material

Stainless steel (1,4305 AISI 303).

standard.

Technical Notes

Similar to DIN 71 752/DIN ISO 8140/CETOP

Tips

Other Tolerances: For r_1 , radius or 45° bevelling.

Order No.	Size	Thread hand	d_1 tol. H9	l_1 ± 0.5	d_2	l_2 ± 0.2	l_3 ± 0.4	l_4 ± 0.2	l_5	w_1 $+0.7 -0.15$	w_2 $+0.5 +0.2$	w_3 tol. h11	f_1 ± 0.2	r_1	Weight g
65646.W0006	6x12	Left	6	12	M6	44	37	20	15	6	12	12	0.5	0.8	15
65646.W0008	8x16	Left	8	16	M8	57	47	25	20	8	16	16	0.5	0.8	36
65646.W0010	10x20	Left	10	20	M10	69	57	30	25	10	20	20	0.5	0.8	68
65646.W0012	12x24	Left	12	24	M12	82	68	35	30	12	24	24	0.5	0.8	112
65646.W0014	14x28	Left	14	28	M14	94	78	40	35	14	27	27	1.0	1.2	171
65646.W0016	16x32	Left	16	32	M16	108	89	45	40	16	32	32	1.0	1.2	288
65646.W0020	20x40	Left	20	40	M20	134	109	55	50	20	40	40	1.0	1.5	550



Mating Piece for Clevis Joints

silver zinc plated

Clevis Joints

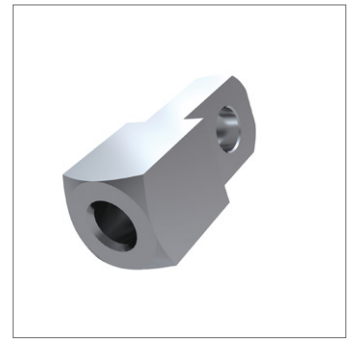
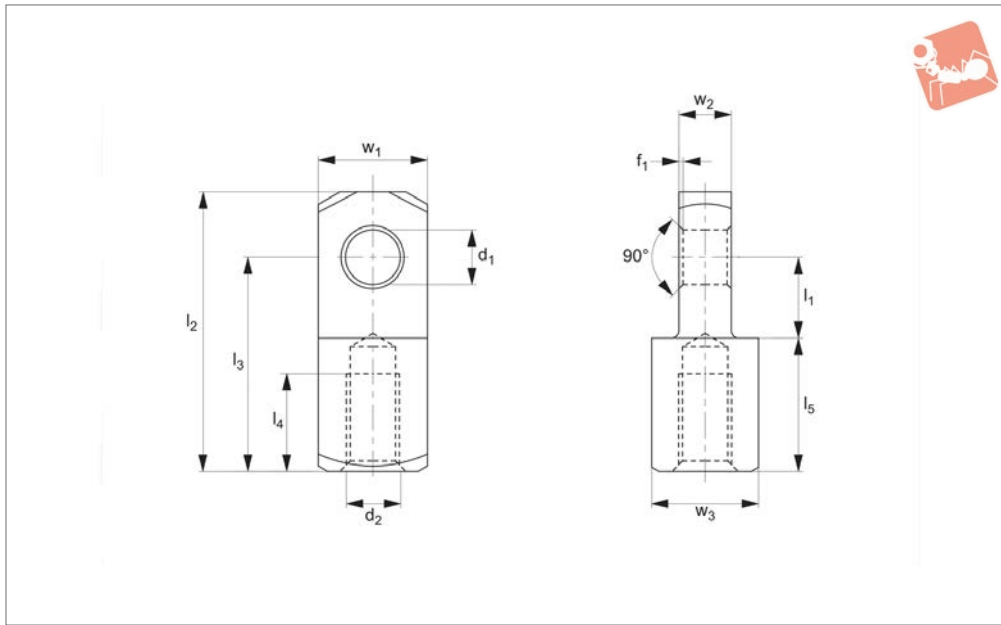

65652

CLEVIS JOINTS

Material

Steel (1.0718), silver zinc plated.

hand thread, see 65653).

Thin end of mating piece is designed to fit in between forks of clevis joint.

joint, (e.g. M5 mating piece will fit on M5 clevis joint).

Tips

Standard thread is right hand, (for left

Designed so thread size matches clevis

Order No.	Thread hand	Thread type	d ₁ tol. H9	l ₁ ±0.5	d ₂	l ₂ ±0.5	l ₃ ±0.5	l ₄	l ₅ ±0.2	w ₁ tol. h11	w ₂ -0,2	w ₃ tol. h11	f ₁ ±0.2	Weight g
65652.W0004	Right	Coarse	4	6.0	M4	21	16	6	10	8	4	8	0.5	6
65652.W0005	Right	Coarse	5	7.5	M5	26	20	8	12.5	10	5	10	0.5	12
65652.W0006	Right	Coarse	6	9.0	M6	31	24	11	15	12	6	12	0.5	21
65652.W0008	Right	Coarse	8	12.0	M8	42	32	14	20	16	8	16	0.5	51
65652.W0009	Right	Fine	8	12.0	M8x1	42	32	14	20	16	8	16	0.5	51
65652.W0010	Right	Coarse	10	15.0	M10	52	40	18	25	20	10	20	0.5	98
65652.W0011	Right	Fine	10	15.0	M10x1,25	52	40	18	25	20	10	20	0.5	98
65652.W0012	Right	Coarse	12	18.0	M12	62	48	22	30	24	12	24	0.5	168
65652.W0013	Right	Fine	12	18.0	M12x1,25	62	48	22	30	24	12	24	0.5	167
65652.W0014	Right	Coarse	14	21.0	M14	72	56	25	35	27	14	27	1.0	247
65652.W0015	Right	Fine	14	21.0	M14x1,5	72	56	25	35	27	14	27	1.0	245
65652.W0016	Right	Coarse	16	24.0	M16	83	64	30	40	32	16	32	1.0	397
65652.W0017	Right	Fine	16	24.0	M16x1,5	83	64	30	40	32	16	32	1.0	395
65652.W0020	Right	Coarse	20	30.0	M20	105	80	38	50	40	20	40	1.0	783
65652.W0021	Right	Fine	20	30.0	M20x1,5	105	80	38	50	40	20	40	1.0	776

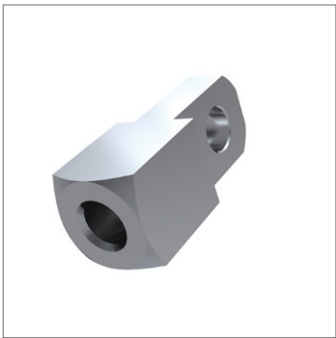

65653

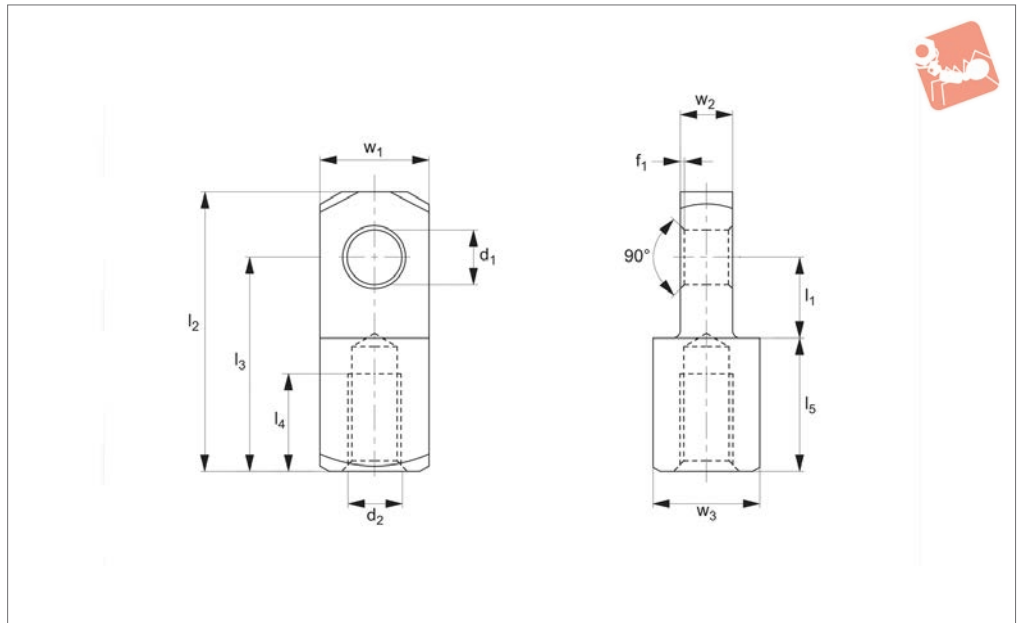

Material

Steel (1.0718), silver zinc plated.

Tips

Thin end of mating piece is designed to fit

in between forks of clevis joint.

Designed so thread size matches clevis joint, (e.g. M5 mating piece will fit on M5 clevis joint).

Order No.	Thread hand	Thread type	d ₁ tol. H9	l ₁ ±0.5	d ₂	l ₂ ±0.5	l ₃ ±0.5	l ₄	l ₅ ±0.2	w ₁ tol. h11	w ₂ -0,2	w ₃ tol. h11	f ₁ ±0.2	Weight g
65653.W1004	Left	Coarse	4	6	M4	21	16	6	10.0	8	4	8	0.5	6
65653.W1005	Left	Coarse	5	7.5	M5	26	20	8	12.5	10	5	10	0.5	12
65653.W1006	Left	Coarse	6	9	M6	31	24	11	15.0	12	6	12	0.5	21
65653.W1008	Left	Coarse	8	12	M8	42	32	14	20.0	16	8	16	0.5	51
65653.W1009	Left	Fine	8	12	M8x1	42	32	14	20.0	16	8	16	0.5	51
65653.W1010	Left	Coarse	10	15	M10	52	40	18	25.0	20	10	20	0.5	98
65653.W1011	Left	Fine	10	15	M10x1,25	52	40	18	25.0	20	10	20	0.5	98
65653.W1012	Left	Coarse	12	18	M12	62	48	22	30.0	24	12	24	0.5	168
65653.W1013	Left	Fine	12	18	M12x1,25	62	48	22	30.0	24	12	24	0.5	167
65653.W1014	Left	Coarse	14	21	M14	72	56	25	35.0	27	14	27	1.0	247
65653.W1015	Left	Fine	14	21	M14x1,5	72	56	25	35.0	27	14	27	1.0	245
65653.W1016	Left	Coarse	16	24	M16	83	64	30	40.0	32	16	32	1.0	397
65653.W1017	Left	Fine	16	24	M16x1,5	83	64	30	40.0	32	16	32	1.0	395
65653.W1020	Left	Coarse	20	30	M20	105	80	38	50.0	40	20	40	1.0	783
65653.W1021	Left	Fine	20	30	M20x1,5	105	80	38	50.0	40	20	40	1.0	776

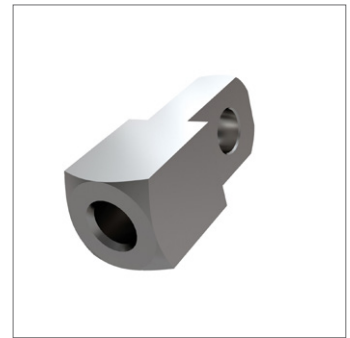
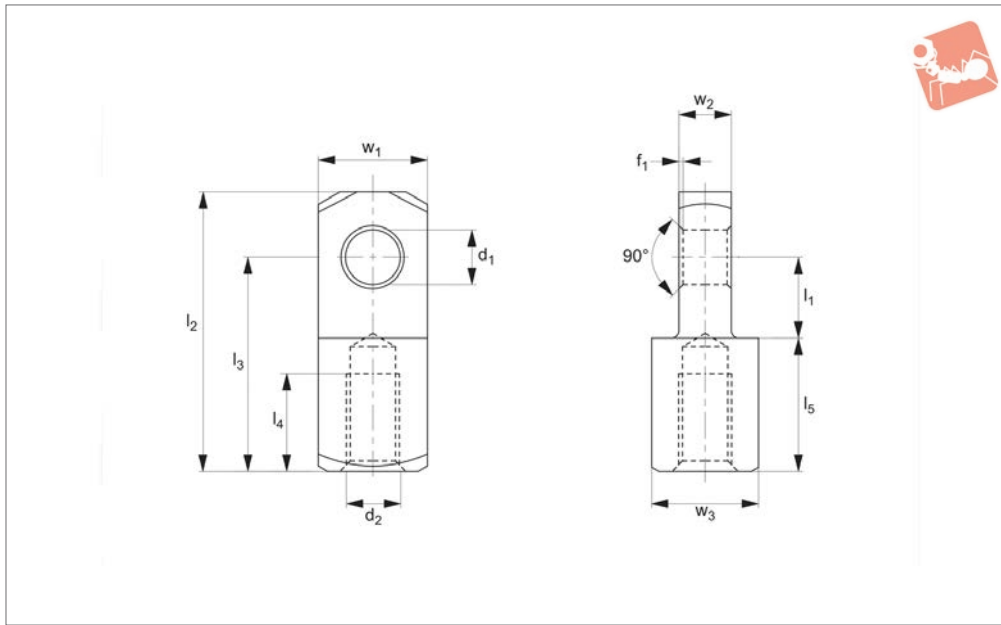

65656

CLEVIS JOINTS

Material

Stainless steel (AISI 303 1.4305).

hand thread see 65657).

clevis joint).

Thin end of mating piece is designed to fit in between forks of clevis joint.

Tips

Standard thread is right hand, (for left

Designed so thread size matches clevis joint, (e.g. M5 mating piece will fit on M5

Order No.	Thread hand	Thread type	d ₁ tol. H9	l ₁ ±0.5	d ₂	l ₂ ±0.5	l ₃ ±0.5	l ₄	l ₅ ±0.2	w ₁ tol. h11	w ₂ -0,2	w ₃ tol. h11	f ₁ ±0.2	Weight g
65656.W0004	Right	Coarse	4	6	M4	21	16	6	10.0	8	4	8	0.5	6
65656.W0005	Right	Coarse	5	7.5	M5	26	20	8	12.5	10	5	10	0.5	12
65656.W0006	Right	Coarse	6	9	M6	31	24	11	15.0	12	6	12	0.5	21
65656.W0008	Right	Coarse	8	12	M8	42	32	14	20.0	16	8	16	0.5	51
65656.W0009	Right	Fine	8	12	M8x1	42	32	14	20.0	16	8	16	0.5	51
65656.W0010	Right	Coarse	10	15	M10	52	40	18	25.0	20	10	20	0.5	98
65656.W0011	Right	Fine	10	15	M10x1,25	52	40	18	25.0	20	10	20	0.5	98
65656.W0012	Right	Coarse	12	18	M12	62	48	22	30.0	24	12	24	0.5	168
65656.W0013	Right	Fine	12	18	M12x1,25	62	48	22	30.0	24	12	24	0.5	167
65656.W0014	Right	Coarse	14	21	M14	72	56	25	35.0	27	14	27	1.0	247
65656.W0015	Right	Fine	14	21	M14x1,5	72	56	25	35.0	27	14	27	1.0	245
65656.W0016	Right	Coarse	16	24	M16	83	64	30	40.0	32	16	32	1.0	397
65656.W0017	Right	Fine	16	24	M16x1,5	83	64	30	40.0	32	16	32	1.0	395
65656.W0020	Right	Coarse	20	30	M20	105	80	38	50.0	40	20	40	1.0	783
65656.W0021	Right	Fine	20	30	M20x1,5	105	80	38	50.0	40	20	40	1.0	776



CLEVIS JOINTS

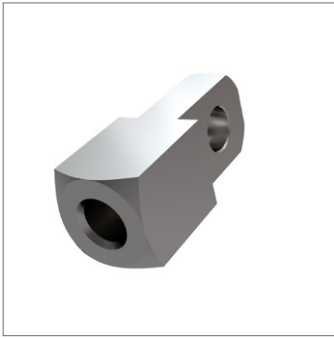

65657

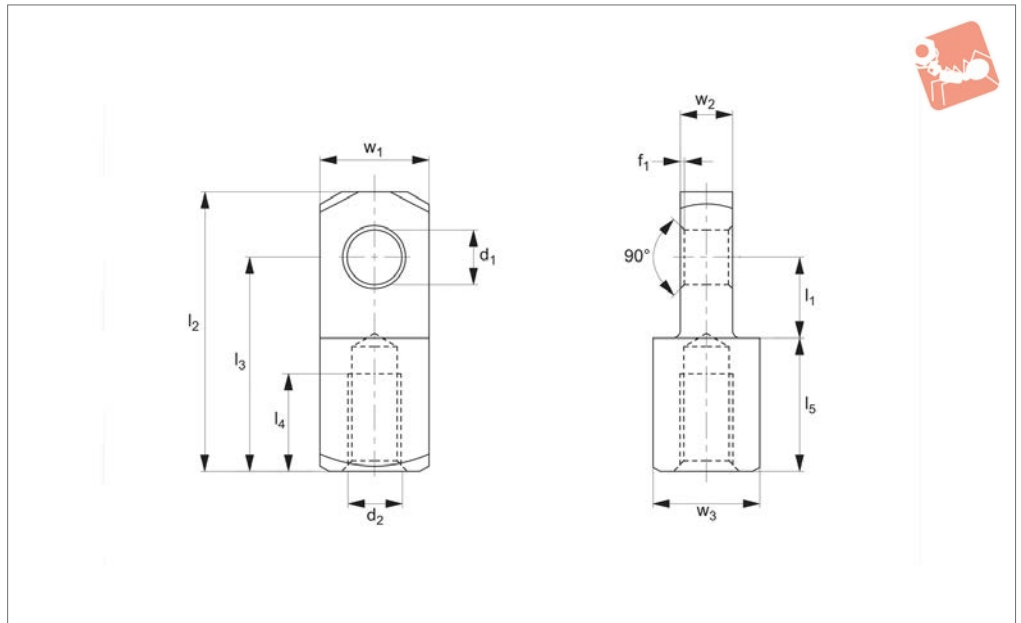

Material

Stainless steel (AISI 303 1.4305).

Tips

Thin end of mating piece is designed to fit

in between forks of clevis joint.

Designed so thread size matches clevis joint, (e.g. M5 mating piece will fit on M5 clevis joint).

Order No.	Thread hand	Thread type	d ₁ tol. H9	l ₁ ±0.5	d ₂	l ₂ ±0.5	l ₃ ±0.5	l ₄	l ₅ ±0.2	w ₁ tol. h11	w ₂ -0,2	w ₃ tol. h11	f ₁ ±0.2	Weight g
65657.W0004	Left	Coarse	4	6	M4	21	16	6	10.0	8	4	8	0.5	6
65657.W0005	Left	Coarse	5	7.5	M5	26	20	8	12.5	10	5	10	0.5	12
65657.W0006	Left	Coarse	6	9	M6	31	24	11	15.0	12	6	12	0.5	21
65657.W0008	Left	Coarse	8	12	M8	42	32	14	20.0	16	8	16	0.5	51
65657.W0009	Left	Fine	8	12	M8x1	42	32	14	20.0	16	8	16	0.5	51
65657.W0010	Left	Coarse	10	15	M10	52	40	18	25.0	20	10	20	0.5	98
65657.W0011	Left	Fine	10	15	M10x1,25	52	40	18	25.0	20	10	20	0.5	98
65657.W0012	Left	Coarse	12	18	M12	62	48	22	30.0	24	12	24	0.5	168
65657.W0013	Left	Fine	12	18	M12x1,25	62	48	22	30.0	24	12	24	0.5	167
65657.W0014	Left	Coarse	14	21	M14	72	56	25	35.0	27	14	27	1.0	247
65657.W0015	Left	Fine	14	21	M14x1,5	72	56	25	35.0	27	14	27	1.0	245
65657.W0016	Left	Coarse	16	24	M16	83	64	30	40.0	32	16	32	1.0	397
65657.W0017	Left	Fine	16	24	M16x1,5	83	64	30	40.0	32	16	32	1.0	395
65657.W0020	Left	Coarse	20	30	M20	105	80	38	50.0	40	20	40	1.0	783
65657.W0021	Left	Fine	20	30	M20x1,5	105	80	38	50.0	40	20	40	1.0	776



Clevis Retention Clips

silver zinc plated

Clevis Joints

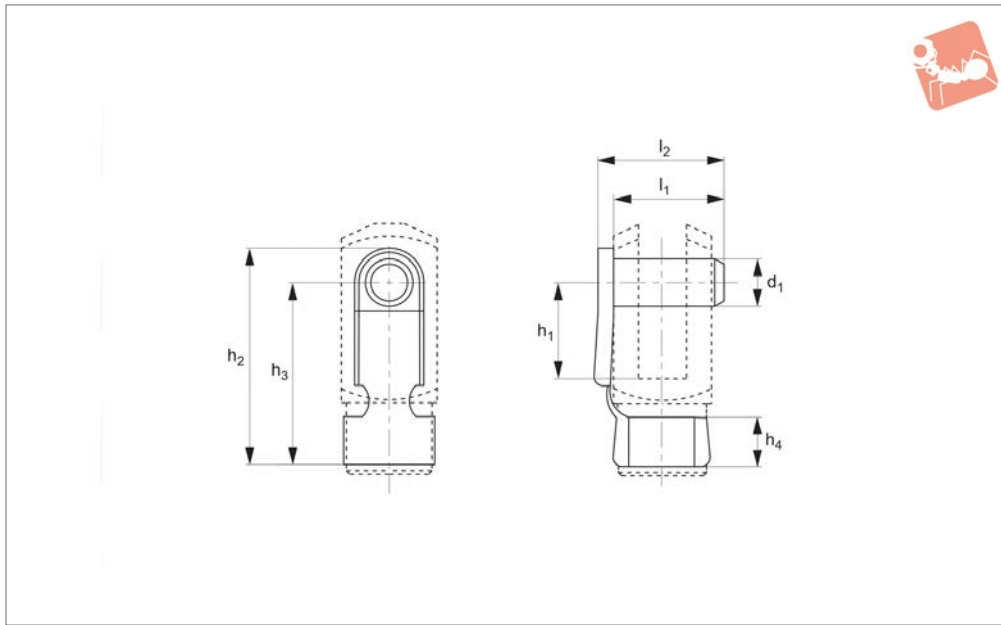

65684

CLEVIS JOINTS

Material

Pin - steel (9SMnPb28), spring - carbon steel C70, silver zinc plated.

Tips

Clips on to base of clevis joint, for clevis joint see part numbers 65630 and 65631.

Order No.	Size	d ₁ tol. H11	h ₁	h ₂	h ₃	h ₄	l ₁	l ₂	Weight g
65684.W0048	4x8	4	8	19	15	4	9	11	2
65684.W0051	5x10	5	10	23	19	4.5	12	14	3
65684.W0052	5x20	5	20	33	29	4.5	12	14	3
65684.W0061	6x12	6	12	28	23	6	14	16	5
65684.W0062	6x24	6	24	40	35	6	14	16	5
65684.W0081	8x16	8	16	37	31	8	19	23	11
65684.W0083	8x32	8	32	53	47	8	19	23	12
65684.W0102	10x20	10	20	46	39	10	23	27	19
65684.W0104	10x40	10	40	66	59	10	23	27	20
65684.W0122	12x24	12	24	55	46	12	28	32	32
65684.W0124	12x48	12	48	79	71	12	28	32	34
65684.W0142	14x28	14	28	62	52	14	31	34	47
65684.W0145	14x56	14	56	92	82	14	31	34	50
65684.W0163	16x32	16	32	72	62	16	36	41	67
65684.W0166	16x64	16	64	103	92	16	36	39	74
65684.W0204	20x40	20	40	88	72	16	44	49	130



CLEVIS JOINTS



65660

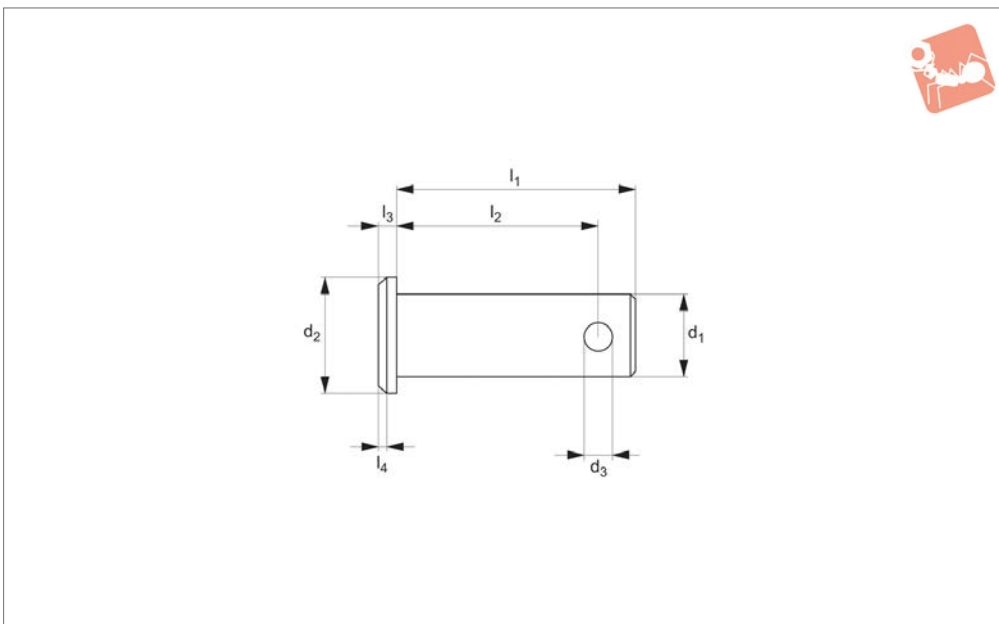

Material

Sizes 5-14 steel 1,0214 (QST 36-3).
 Sizes 16-50 steel (1,0718 11SMnPb30+C).
 Zinc-plated.

Tips

For use with clevis joints 65630 and 65631,
 for split cotter pins to suit see part number
 65674.
 For washers see part number P0330-ZP.

Technical Notes

Designed for use with clevis joints.

Order No.	d ₁ tol. h11	d ₂ tol. h14	d ₃ tol. h14	l ₁ tol. js15	l ₂ +0.5	l ₃ tol. js14	l ₄	Weight g
65660.W0105	5	8	1.0	15	12.3	1.5	0.5	2.6
65660.W0106	6	9	1.6	18	15.3	1.5	0.5	4.6
65660.W0108	8	12	2.0	23	19.5	2.0	1.0	10.0
65660.W0110	10	14	3.2	29	24.5	2.0	1.0	19.0
65660.W0112	12	17	4.0	35	29.5	3.0	1.5	34.0
65660.W0114	14	19	4.0	40	32.5	3.0	1.5	53.0
65660.W0116	16	20	4.0	45	38.2	3.5	1.5	72.0
65660.W0118	18	25	5.0	50	43.5	3.5	1.5	104.0
65660.W0120	20	28	5.0	53	47.0	4.0	1.5	139.0
65660.W0125	25	34	6.3	67	59.0	5.5	1.5	266.0
65660.W0128	28	34	6.3	72	63.2	5.5	2.0	361.0
65660.W0130	30	36	6.3	77	68.2	5.5	2.0	428.0
65660.W0135	35	45	8.0	87	76.5	7.0	2.0	677.0
65660.W0140	40	48	8.0	100	90.0	6.0	5.0	1035.0
65660.W0142	42	48	8.0	100	90.0	7.0	5.0	1151.0
65660.W0150	50	58	10.0	115	103.0	7.0	6.0	1846.0

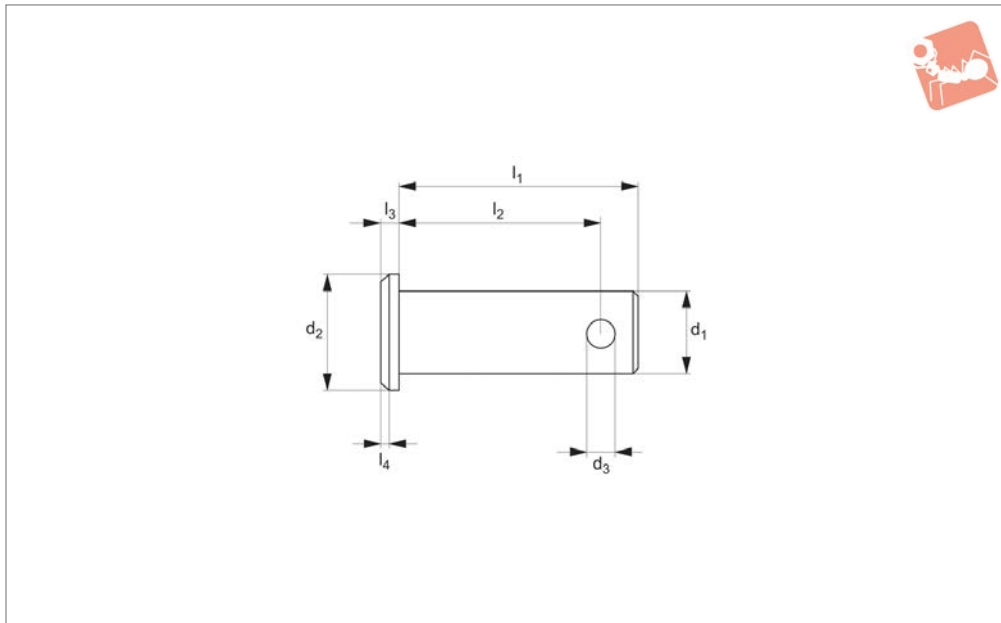

65661

CLEVIS JOINTS

Material

Stainless steel (1.4305, X8CrNiS18-9), for sizes 6-8: stainless steel (1.4567, X3CrNiCu18-9-4).

Tips

For use with clevis joints 65635 and 65636, for split cotter pins to suit see part number 65675.

For washers see part number 65671.

Technical Notes

Designed for use with clevis joints.

Order No.	d_1 tol. h11	d_2 tol. h14	d_3 tol. h14	l_1 tol. js15	l_2 +0.5	l_3 tol. js14	l_4	Weight g
65661.W0005	5	8	1.2	15	12.3	1.5	0.5	2.6
65661.W0006	6	9	1.6	18	15.3	1.5	0.5	4.6
65661.W0008	8	12	2.0	23	19.5	2.0	1.0	10.0
65661.W0010	10	14	3.2	29	24.5	2.0	1.0	19.0
65661.W0012	12	17	4.0	35	29.5	3.0	1.5	34.0
65661.W0014	14	19	4.0	40	32.5	3.0	1.5	53.0
65661.W0016	16	21	4.0	45	38.2	3.0	-	73.0
65661.W0020	20	28	5.0	53	47.0	4.0	-	139.0
65661.W0025	25	34	6.3	67	59.0	5.5	-	266.0



65664

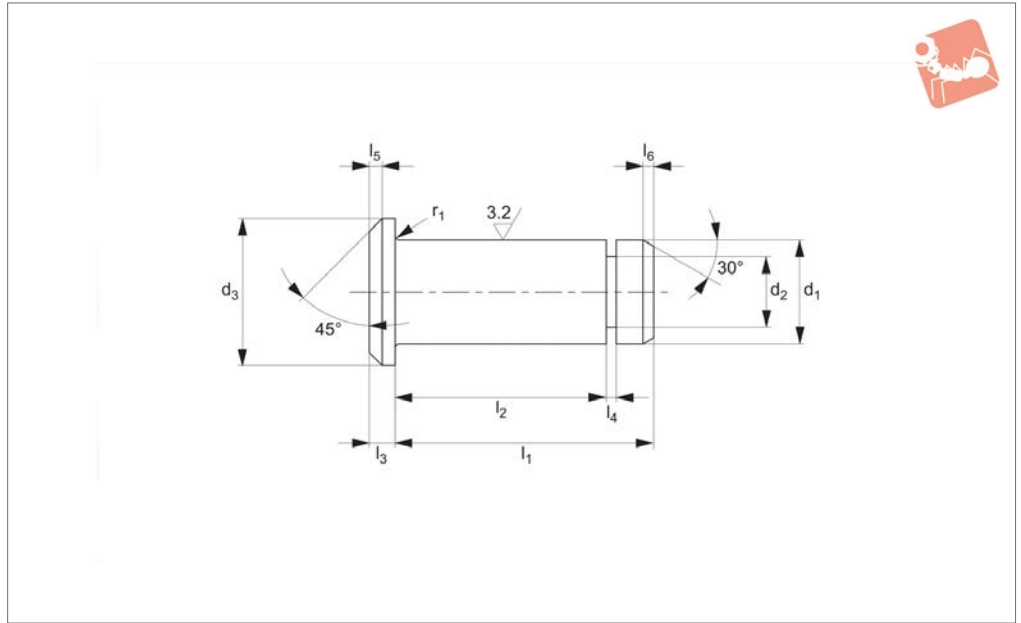

Material

Steel (9SMnPb28), silver zinc plated.

Tips

For safety fasteners, see 65680-.

Technical Notes

Designed for use with clevis joints.

Order No.	d ₁ tol. h11	d ₂ tol. h11	d ₃ tol. h12	l ₁	l ₂ +0.30	l ₃ tol. js14	l ₄ +0.10	l ₅	l ₆	R	Weight g
65664.W0104	4	3.2	6	10.5	8.5	1.0	0.64	0.5	0.5	0.3	2
65664.W0105	5	4.0	8	13.0	10.5	1.5	0.74	0.5	0.5	0.5	3
65664.W0106	6	5.0	9	15.5	12.5	1.5	0.74	0.5	0.75	0.5	4
65664.W0108	8	6.0	12	20.0	16.5	2.0	0.94	1.0	1.0	0.5	9
65664.W0110	10	8.0	14	25.0	20.5	2.0	1.05	1.0	1.0	0.5	17
65664.W0112	12	9.0	17	30.0	24.5	3.0	1.15	1.25	1.25	0.5	30
65664.W0114	14	10.0	19	33.0	27.5	3.0	1.25	1.5	1.5	1.0	48
65664.W0116	16	12.0	20	38.5	32.5	3.0	1.35	1.5	1.5	1.0	67
65664.W0120	20	17.5	26	46.0	40.5	4.0	1.8	2.0	1.5	1.0	125
65664.W0125	25	18.0	32	57.0	50.5	5.0	1.8	2.0	1.5	1.0	260

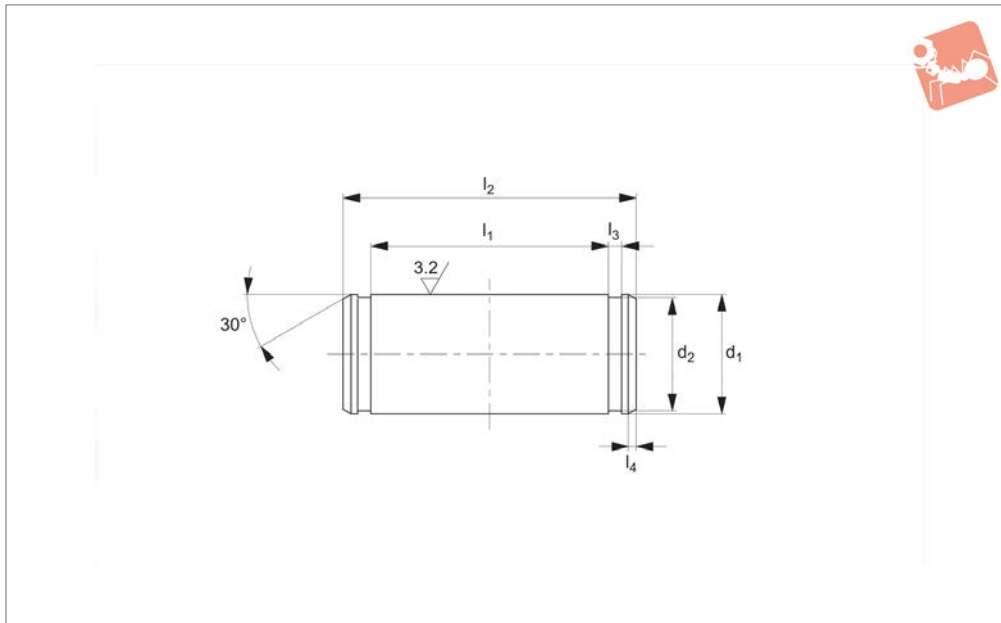

65666

CLEVIS JOINTS

Material

Stainless steel (AISI 303).

Technical Notes

For use with 65635-65636 clevis joints and 65678 circlips.

Order No.	d ₁ tol. h11	d ₂ tol. h11	l ₁ +0.30	l ₂ +0.40	l ₃ tol. h13	l ₄	Weight g
65666.W0005	5	4.8	10.5	15	0.7	1	3
65666.W0006	6	5.7	12.2	17	0.8	1	5
65666.W0008	8	7.6	16.5	20	0.9	1	8
65666.W0010	10	9.6	20.5	25	1.1	1	15
65666.W0012	12	11.5	24.5	30	1.1	1	26
65666.W0016	16	15.2	32.5	39	1.1	1	61
65666.W0020	20	19.0	40.5	48	1.3	1	118

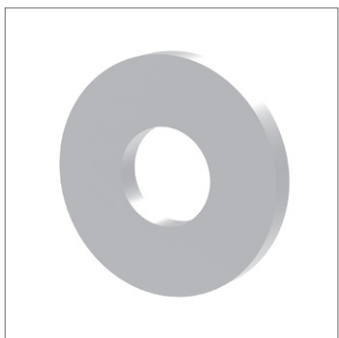

65670

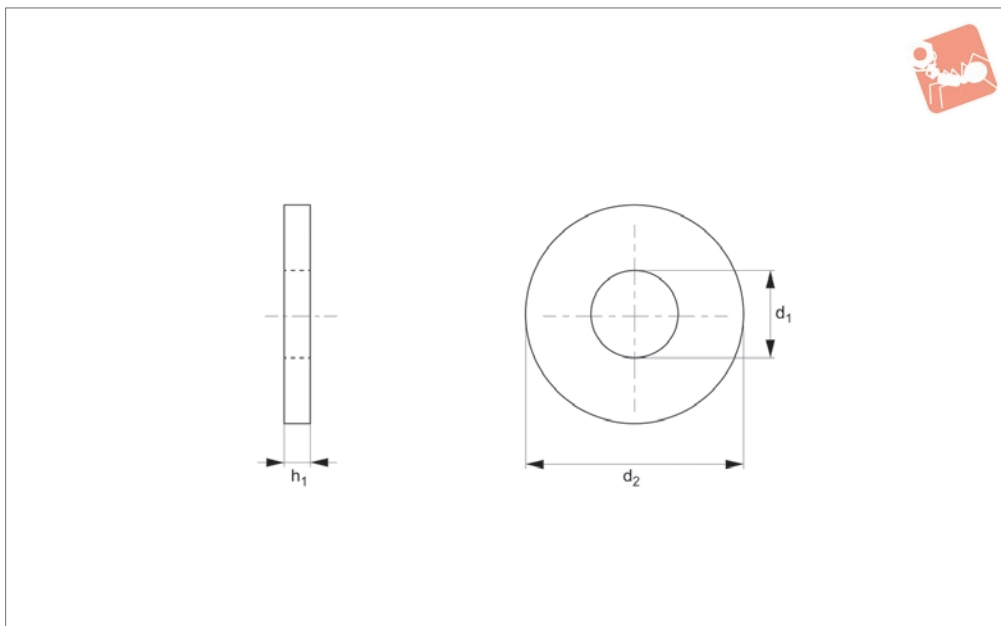

Material

Steel, zinc-plated.

Technical Notes

To DIN 125 A.

Order No.	For thread	d_1	d_2	h_1	Material
65670.W0004	M 4	4.3	9	0.8	Steel ZP
65670.W0005	M 5	5.3	10	1.0	Steel ZP
65670.W0006	M 6	6.4	12	1.6	Steel ZP
65670.W0007	M 7	7.4	14	1.6	Steel ZP
65670.W0008	M 8	8.4	16	1.6	Steel ZP
65670.W0010	M10	10.5	20	2.0	Steel ZP
65670.W0012	M12	13.0	24	2.5	Steel ZP
65670.W0014	M14	15.0	28	2.5	Steel ZP
65670.W0016	M16	17.0	30	3.0	Steel ZP
65670.W0018	M18	19.0	34	3.0	Steel ZP
65670.W0020	M20	21.0	37	3.0	Steel ZP
65670.W0022	M22	23.0	39	3.0	Steel ZP
65670.W0025	M24	25.0	44	4.0	Steel ZP
65670.W0028	M27	28.0	50	4.0	Steel ZP
65670.W0030	M30	31.0	56	4.0	Steel ZP



Flat Washers Form A

A2 stainless

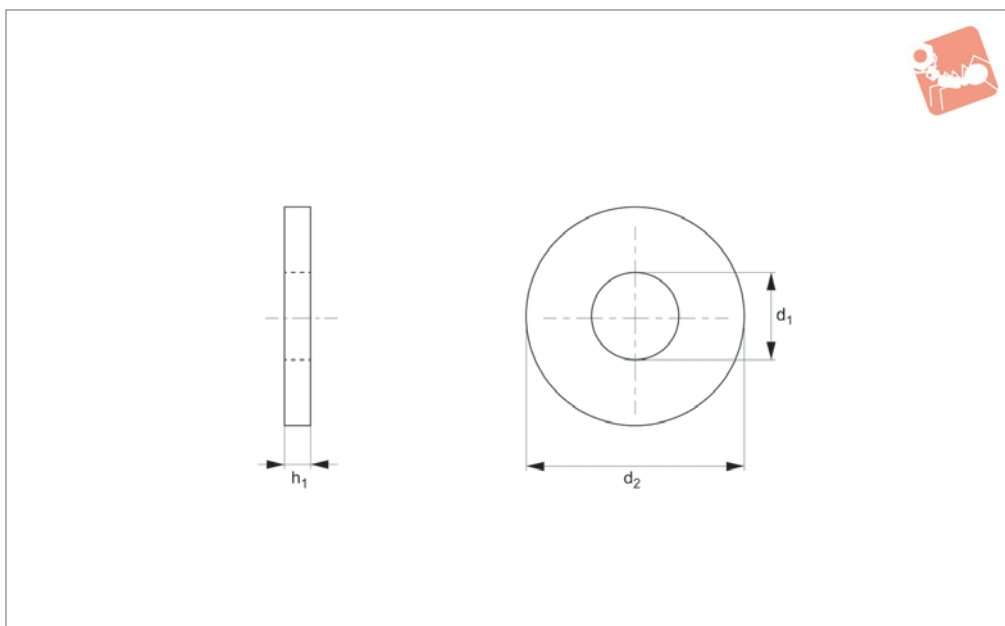

65671

CLEVIS JOINTS

Material

Stainless steel (A2).

Technical Notes

To DIN 125 A.

Order No.	For thread	d_1	d_2	h_1	Material
65671.W0004	M 4	4.3	9	0.8	A2 s/s
65671.W0005	M 5	5.3	10	1.0	A2 s/s
65671.W0006	M 6	6.4	12	1.6	A2 s/s
65671.W0007	M 7	7.4	14	1.6	A2 s/s
65671.W0008	M 8	8.4	16	1.6	A2 s/s
65671.W0010	M10	10.5	20	2.0	A2 s/s
65671.W0012	M12	13.0	24	2.5	A2 s/s
65671.W0014	M14	15.0	28	2.5	A2 s/s
65671.W0016	M16	17.0	30	3.0	A2 s/s
65671.W0020	M20	21.0	37	3.0	A2 s/s
65671.W0025	M24	25.0	44	4.0	A2 s/s



65674

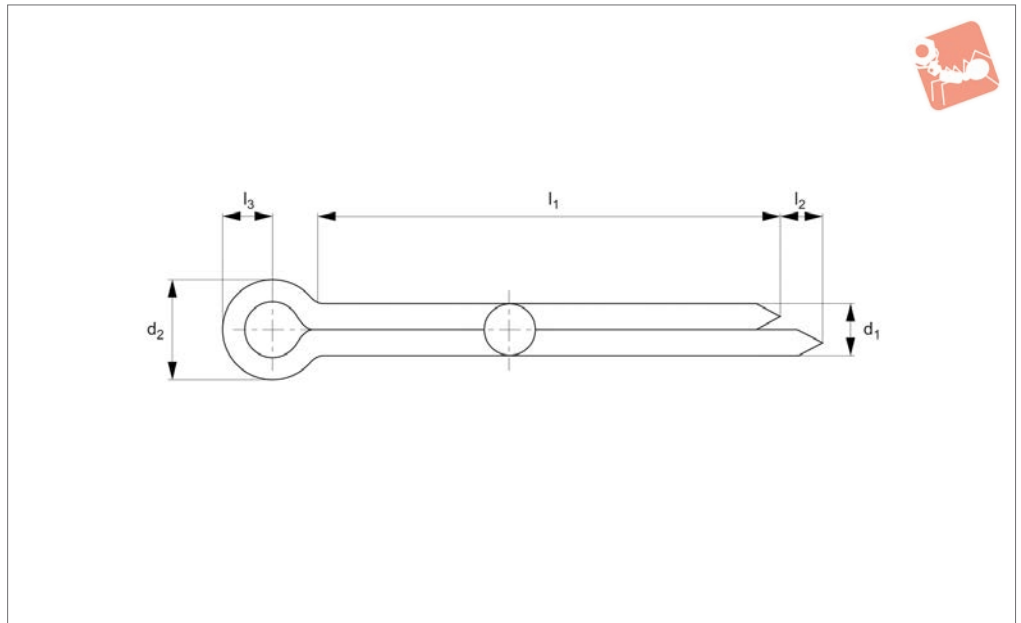

Material

Mild steel (zinc-plated).

pins require a loose fit, and as a result the metric versions can also be for inch sizes.

H14 (under this diameter recommended tolerance is H13).

Technical Notes

To DIN 94 (equivalent to ISO 1234). Cotter

Recommended hole tolerance for d_1 1,6 is

Order No.	d_1 nom.	d_1 min.	d_1 max.	d_2 max.	l_1	l_2 max.	l_3 ≈
65674.W0010	1	0.8	0.9	1.8	10	1.6	3
65674.W0016	1.6	1.3	1.4	2.8	18	2.5	3.2
65674.W0020	2	1.7	1.8	3.6	18	2.5	4.0
65674.W0032	3.2	2.7	2.9	5.8	22	3.2	6.4
65674.W0040	4	3.5	3.7	7.4	28	4.0	8.0
65674.W0050	5	4.4	4.6	9.2	50	4.0	10.0
65674.W0060	6	5.7	5.9	11.8	71	4.0	12.6
65674.W0080	8	7.3	7.5	15	112	4.0	16.0
65674.W0100	10	9.3	9.5	19	112	6.3	20.0

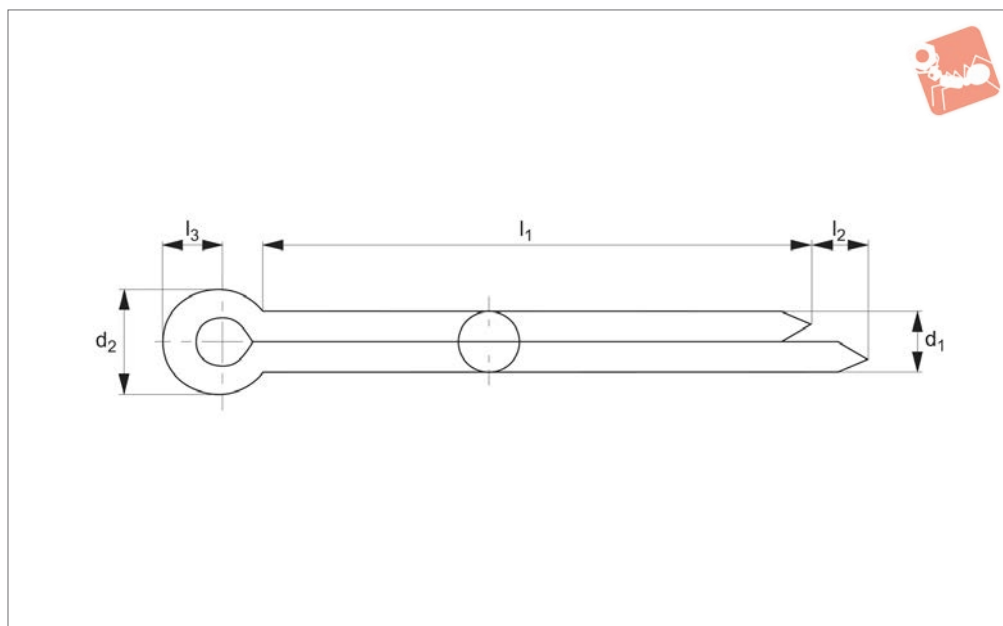
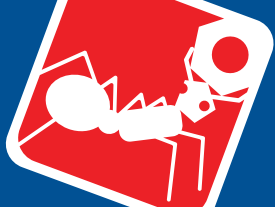

65675

CLEVIS JOINTS

Material

Stainless steel (A2, AISI 303).

pins require a loose fit, and as a result the metric versions can also be for inch sizes.

Technical Notes

To DIN 94 (equivalent to ISO 1234). Cotter

Order No.	d ₁ nom.	d ₂ max.	l ₁	l ₂ max.	l ₃ ≈
65675.W1010	1	1.8	10	1.6	3.0
65675.W1018	1.6	2.8	18	2.5	3.2
65675.W2018	2	3.6	18	2.5	4.0
65675.W3022	3.2	5.8	22	3.2	6.4
65675.W4028	4	7.4	28	4.0	8.0
65675.W5050	5	9.2	50	4.0	10
65675.W6071	6.3	11.8	71	4.0	12.6



65680

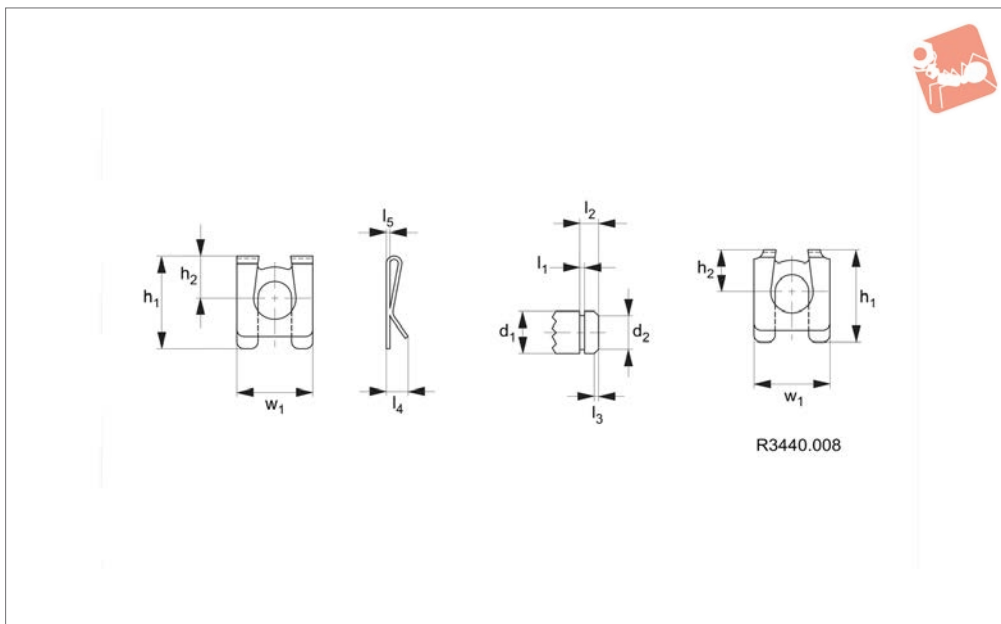

Material

Spring steel, silver zinc plated, hardened and annealed 1450 to 1600°C N/mm².

Tips

Easily assembled and removed by hand

without special tools, compatible with clevis pins.

Safety lip prevents accidental removal.

Assembly ,rattle' is eliminated by the fasteners concave back holding the clevis

pin under tension.

Order No.	d ₁ tol. h11	d ₂ tol. h11	h ₁	h ₂	l ₁ +0.1	l ₂	l ₃	l ₄	l ₅	w ₁	Axial thrust kN max.	Weight g
65680.W0004	4	3.2	8.5	4.0	0.64	2.0	0.5	2.3	0.3	7	1.00	0.19
65680.W0005	5	4.0	10.7	5.0	0.74	2.5	0.5	3.3	0.4	9	1.30	0.34
65680.W0006	6	5.0	14.1	6.0	0.74	3.0	0.75	3.8	0.4	11	1.50	0.63
65680.W0008	8	6.0	17.5	8.0	0.94	3.5	1.0	4.0	0.5	14	3.60	1.10
65680.W0010	10	8.0	22.1	10.0	1.05	4.5	1.0	5.0	0.5	18	6.40	2.11
65680.W0012	12	9.0	26.0	12.0	1.15	5.0	1.25	5.0	0.5	22	9.60	2.80
65680.W0014	14	10.0	30.0	13.5	1.25	5.5	1.5	6.0	0.6	25	11.32	4.74
65680.W0016	16	12.0	34.0	16.0	1.35	6.0	1.5	6.0	0.6	28	13.50	5.63



Safety Fastener (KLM)

silver zinc plated

Clevis Joints

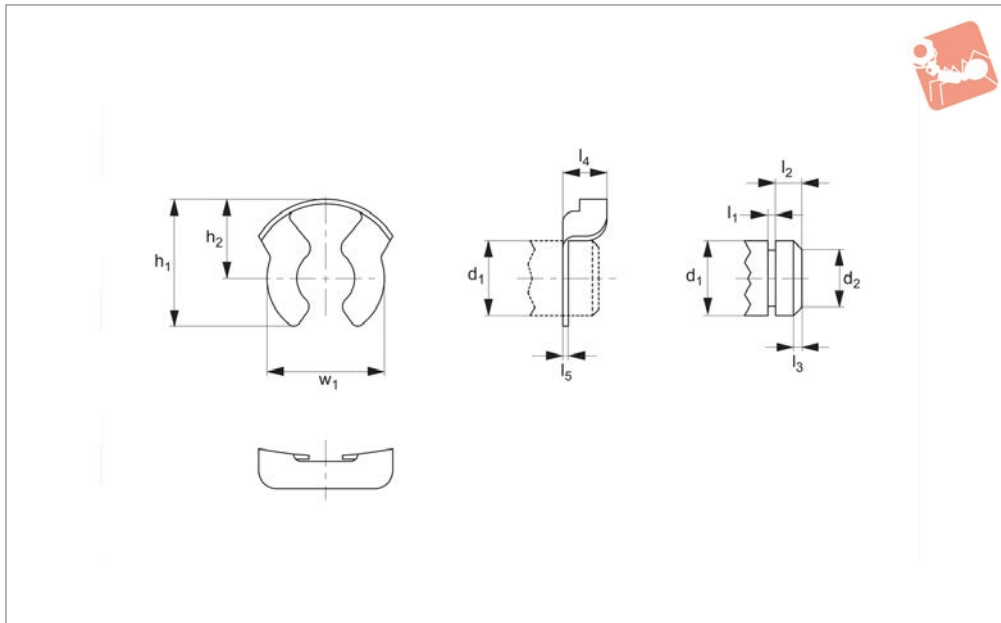

65682

CLEVIS JOINTS

Material

Steel, silver zinc plated.

Tips

Easily assembled and removed by hand without special tools.

Order No.	d ₁ tol. h11	d ₂ tol. h11	h ₁	h ₂	l ₁ +0.10	l ₂	l ₃	l ₄	l ₅	w	Axial force kN max.
65682.W0004	4	3.2	7.2	4.3	0.64	2.0	0.5	2.8	0.4	6.6	1.50
65682.W0005	5	4.0	8.4	5.2	0.74	2.5	0.5	2.8	0.5	7.5	3.00
65682.W0006	6	5.0	11.25	6.8	0.74	3.0	0.75	3.5	0.5	10.6	4.85
65682.W0008	8	6.0	11.9	7.4	0.94	3.5	1.0	4.5	0.5	11.5	5.50
65682.W0010	10	8.0	16.3	9.5	1.05	4.5	1.0	5.9	0.6	15.5	9.50
65682.W0012	12	9.0	18.0	10.5	1.15	5.5	1.25	6.2	0.6	16.8	10.70
65682.W0014	14	10.0	20.0	12.2	1.25	5.5	1.5	6.8	0.7	19.2	12.70
65682.W0016	16-18	12.0	24.0	14.3	1.35	5.5-6.0	1.5	7.6	0.8	22.7	14.00



65678

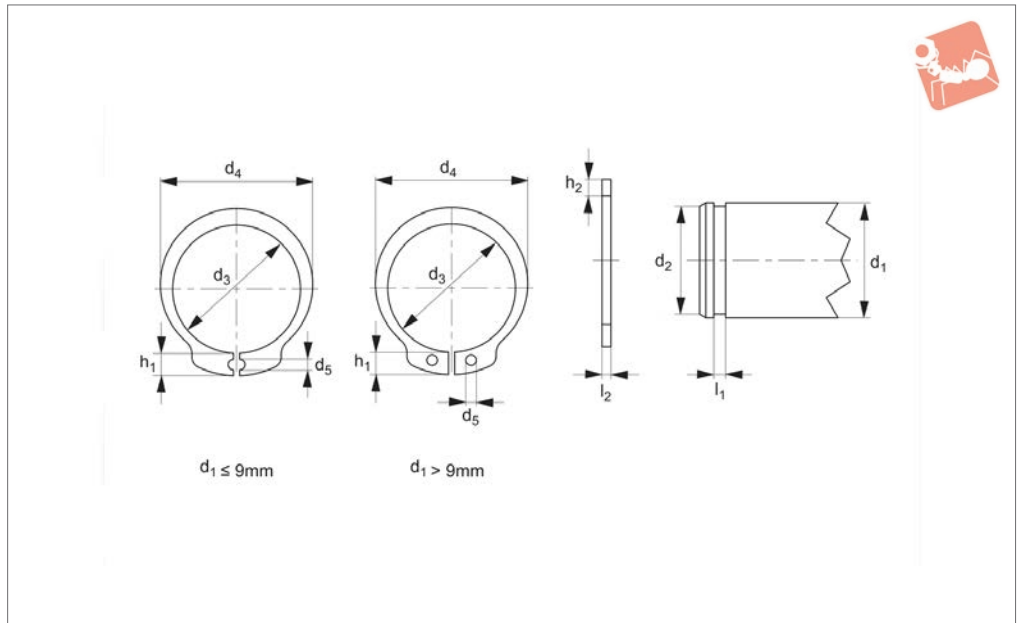

Material

Stainless steel (AISI 303).

Technical Notes

To DIN 471, for use with 65666 clevis pins and 65635-65636 clevis joints.

Order No.	d ₁	d ₂	d ₃	d ₄	d ₅ min.	h ₁	h ₂	l ₁	l ₂
65678.W0005	5	4.8	3.7	6.2	1.0	2.5	1.1	0.7	0.6
65678.W0006	6	5.7	5.6	7.5	1.15	2.7	1.3	0.8	0.7
65678.W0010	10	9.6	9.3	12.7	1.7	3.3	1.8	1.1	1.0
65678.W0012	12	11.5	11.0	7.7	1.7	3.3	1.8	1.1	1.0
65678.W0016	16	15.2	14.7	12.2	1.7	3.7	2.2	1.1	1.0
65678.W0020	20	19.0	18.5	16.2	2.0	4.0	2.6	1.3	1.2



Single Universal Joint

Steel

Universal Joints

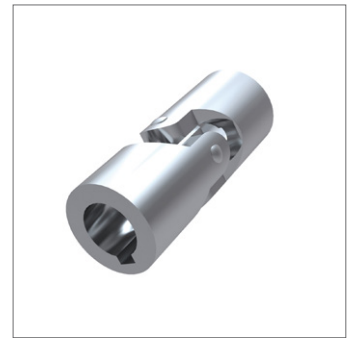
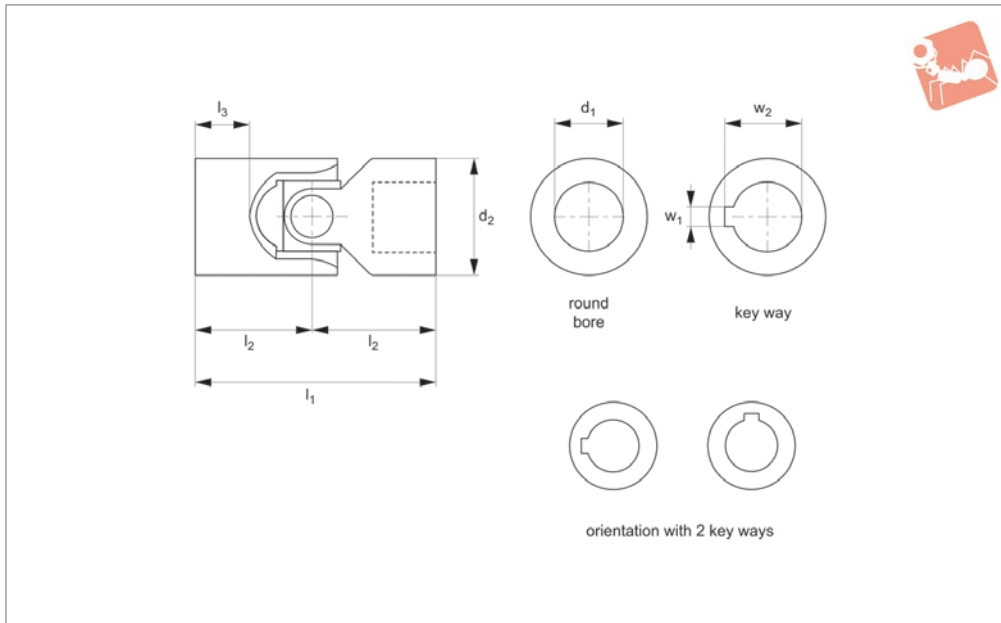

65170

UNIVERSAL JOINTS

Material

Steel (9SMnPb28k, no. 10718).
Bearing type: plain bearing.

Technical Notes

To DIN 808/7551.
Maximum bending angle 45° per joint,

Max. drive speed of 1000 rpm.

Tips

Single universal joints are used where shafts are off-set towards each other.
Product variations available on request, for square bores change the suffix to SQ for

square bores or HX for hex bores.
For stainless steel see 65186

For needle roller bearings see part number

Order No.	Bore dia.	d ₁ tol. H7	d ₂	l ₁	l ₂	l ₃	w ₁ tol. JS9	w ₂	Weight g
65170.W0010	Round bore	10	16	52	26	15	-	-	50
65170.W0012	Round Bore	12	22	62	31	18	-	-	120
65170.W0016	Round Bore	16	25	74	37	21	-	-	200
65170.W0020	Round Bore	20	32	86	43	24	-	-	350
65170.W0025	Round Bore	25	42	108	54	31	-	-	800
65170.W0030	Round Bore	30	50	132	66	38	-	-	1200
65170.W0040	Round Bore	40	70	166	83	47	-	-	2900
65170.W0210	With keyway	10	16	52	26	15	3	11.4	50
65170.W0212	With keyway	12	22	62	31	18	4	13.8	120
65170.W0216	With keyway	16	25	74	37	21	5	18.3	200
65170.W0220	With keyway	20	32	86	43	24	6	22.8	350
65170.W0225	With keyway	25	42	108	54	31	8	28.3	800
65170.W0230	With keyway	30	50	132	66	38	8	33.3	1200
65170.W0240	With keyway	40	70	166	83	47	12	43.3	2900

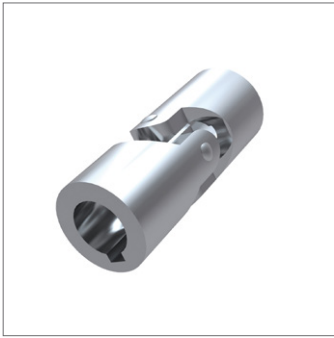

65172

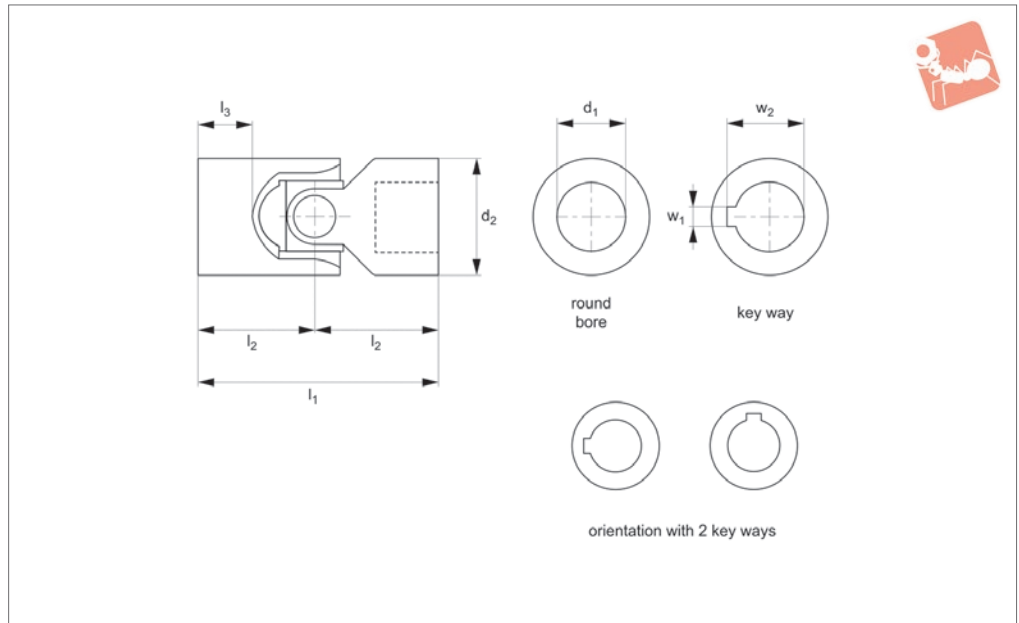

Material

Steel (9SMnPb28k, no. 10718).
Bearing type: plain bearing.

Technical Notes

To DIN 808.

Maximum bending angle 45° per joint.
Max. drive speed of 1000 rpm.

Tips

Single universal joints are used where shafts are off-set towards each other.

Product variations available on request, for square bores change the suffix to SQ for square bores or HX for hex bores.
For stainless steel see 65186.

Order No.	Bore dia.	d_1 tol. H7	d_2	l_1	l_2	l_3	w_1 tol. JS9	w_2	Weight g
65172.W0006	Round bore	6	16	34	17	8	-	-	50
65172.W0008	Round bore	8	16	40	20	11	-	-	50
65172.W0010	Round bore	10	22	48	24	12	-	-	100
65172.W0012	Round bore	12	25	56	28	13	-	-	160
65172.W0014	Round bore	14	28	60	30	14	-	-	200
65172.W0016	Round bore	16	32	68	34	16	-	-	300
65172.W0018	Round bore	18	36	74	37	17	-	-	450
65172.W0020	Round bore	20	42	82	41	18	-	-	600
65172.W0022	Round bore	22	45	95	47.5	22	-	-	950
65172.W0025	Round bore	25	50	108	54	26	-	-	1200
65172.W0030	Round bore	30	58	122	61	29	-	-	1850
65172.W0032	Round bore	32	58	130	65	33	-	-	2000
65172.W0035	Round bore	35	70	140	70	35	-	-	3150
65172.W0040	Round bore	40	80	160	80	39	-	-	4600
65172.W0050	Round bore	50	95	190	95	46	-	-	7600
65172.W0206	With Keyway	6	16	34	17	8	2	7.0	50
65172.W0208	With Keyway	8	16	40	20	11	2	9.0	50
65172.W0210	With Keyway	10	22	48	24	12	3	11.4	100
65172.W0212	With Keyway	12	25	56	28	13	4	13.8	160
65172.W0214	With Keyway	14	28	60	30	14	5	16.3	200
65172.W0216	With Keyway	16	32	68	34	16	5	18.3	300
65172.W0218	With Keyway	18	36	74	37	17	6	20.8	450
65172.W0220	With Keyway	20	42	82	41	18	6	22.8	600
65172.W0222	With Keyway	22	45	95	47.5	22	6	24.8	950
65172.W0225	With Keyway	25	50	108	54	26	8	28.3	1200
65172.W0230	With Keyway	30	58	122	61	29	8	33.3	1850
65172.W0232	With Keyway	32	58	130	65	33	10	35.3	2000
65172.W0235	With Keyway	35	70	140	70	35	10	38.3	3150
65172.W0240	With Keyway	40	80	160	80	39	12	43.3	4600
65172.W0250	With Keyway	50	95	190	95	46	14	53.8	7600



Stainless Single Universal Joint

Stainless

Universal Joints

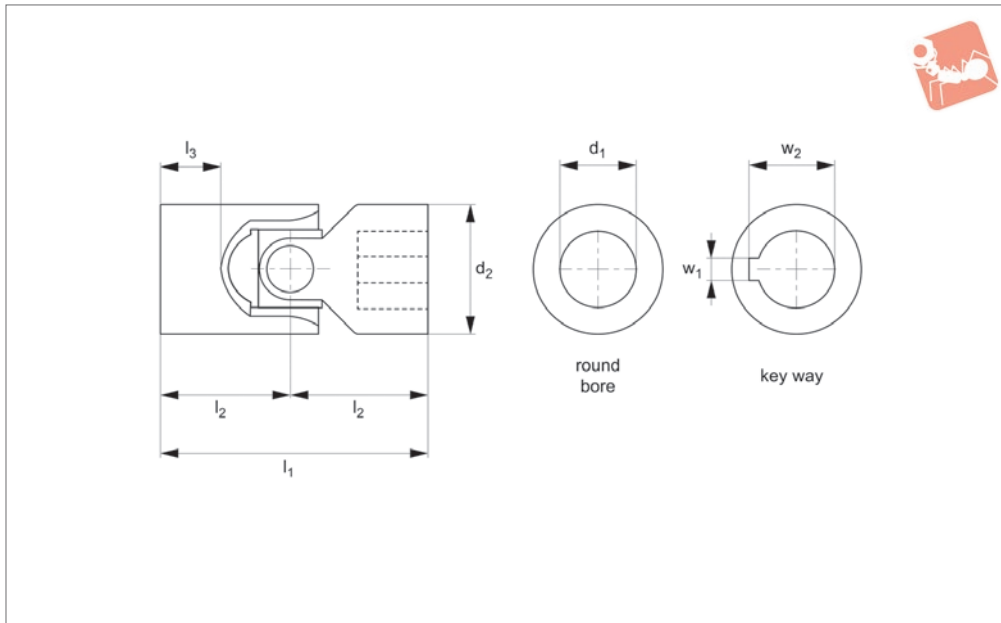

65186

UNIVERSAL JOINTS

Material

Stainless steel (AISI 304)

Technical Notes

To DIN 808, maximum bending angle 45° per joint.

Tips

Single universal joints are used where shafts are off-set towards each other.

Product variations available on request, for square bores change the suffix to SQ for square bores or HX for hex bores.

Order No.	Bore dia.	d_1 tol. H7	d_2	l_1	l_2	l_3	w_1 tol. JS9	w_2	Weight g
65186.W0006	Round bore	6	16	34	17	8	-	-	50
65186.W0008	Round Bore	8	16	40	20	11	-	-	50
65186.W0010	Round Bore	10	22	48	24	12	-	-	100
65186.W0012	Round Bore	12	25	56	28	13	-	-	160
65186.W0016	Round Bore	16	32	68	34	16	-	-	300
65186.W0020	Round Bore	20	42	82	41	18	-	-	600
65186.W0025	Round Bore	25	50	108	54	26	-	-	1200
65186.W0030	Round Bore	30	58	122	61	29	-	-	1850



UNIVERSAL JOINTS



65280

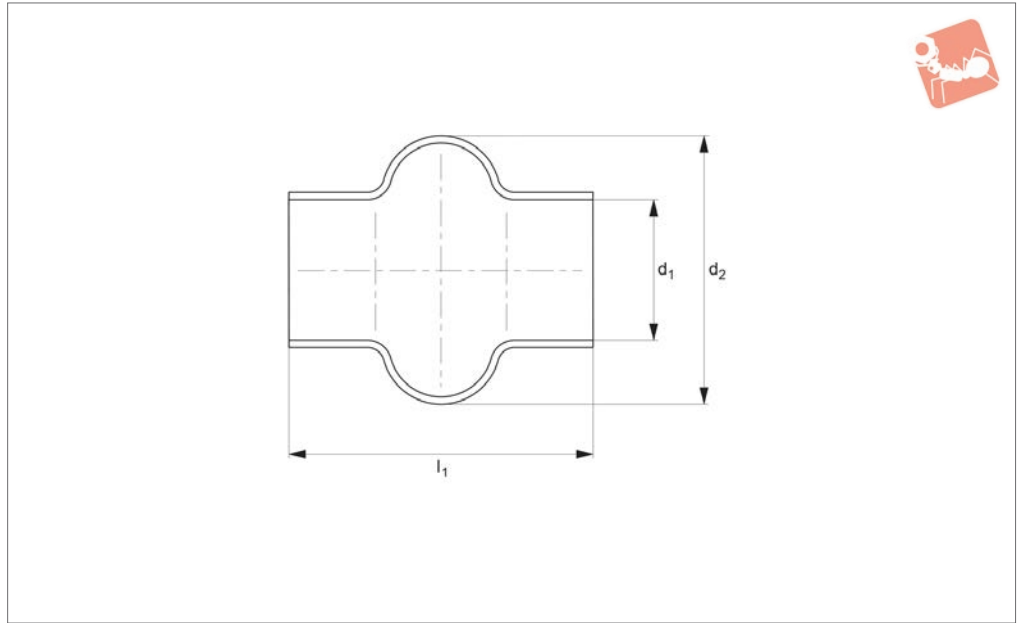

Material

Rubber.

Tips

Bellows give universal joints full protec-

tion against ingress of dirt.

They can be filled with grease which gives long term lubrication for friction bearings. Bellows should be secured at each end with

two cable ties (not supplied).

Order No.	To suit joint of o.d	d ₁	d ₂	l ₁
65280.W0016	16	15.0	28	34
65280.W0018	18	16.5	32	40
65280.W0022	22	20.5	40	45
65280.W0025	25/26	24.5	48	50
65280.W0028	28/29	27.5	52	56
65280.W0032	32	30.5	56	65
65280.W0036	36/37	35.5	66	72
65280.W0042	42	40.0	75	82
65280.W0045	45/47	45.0	84	95
65280.W0050	50/52	50.0	92	108
65280.W0058	58	56.0	100	122



Bellows for double universal joints

Universal Joints

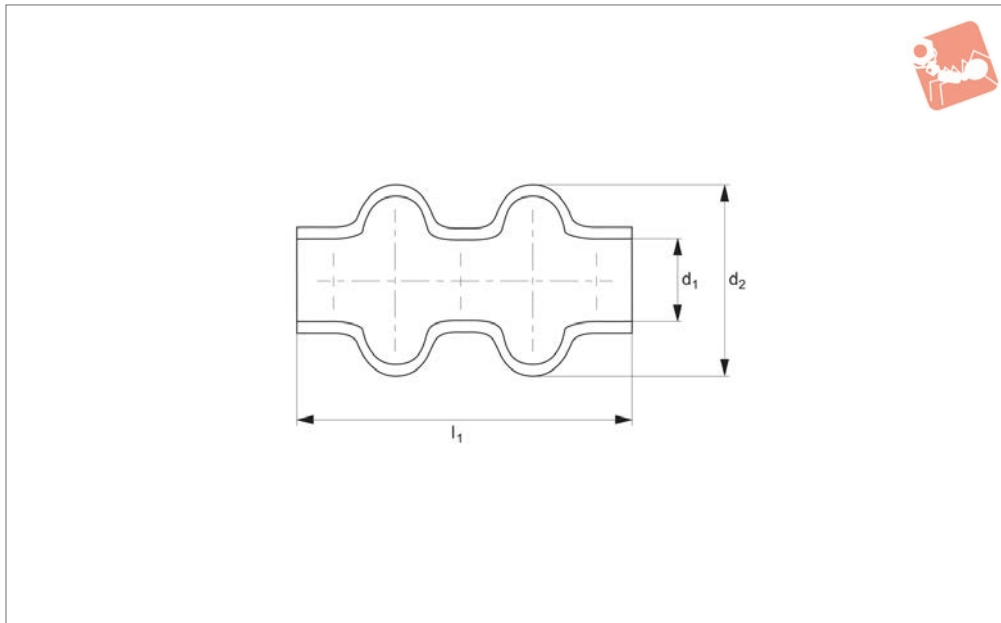

65282

UNIVERSAL JOINTS

Material

Black elastomer plastic (smooth PVC)

Tips

Bellows give universal joints full protec-

tion against ingress of dirt.

They can be filled with grease which gives long term lubrication for friction bearings. Bellows should be secured at each end with two cable ties (not supplied).

Order No.	To suit joint of o.d	d_1	d_2	l_1
65282.W0016	16	16	35	55
65282.W0022	22	20	36	65
65282.W0025	25	24	44	70
65282.W0028	28	28	51	80
65282.W0032	32	32	62	90
65282.W0050	50	50	90	155

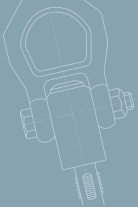

Parts overview

UNIVERSAL JOINTS

Single Universal Joints

Available with plain bearings or needle roller bearings. Plain bore and keyed bores stocked as standard, hex or square shaped bores on request. Bore diameters 6mm up to 50mm.



Double Universal Joints

Available with plain bearings or needle roller bearings. Plain bore and keyed bores stocked as standard, hex or square shaped bores on request. Bore diameters 6mm up to 50mm.



Stainless Steel Universal Joints

Single and double universal joints with plain bearings and plain bores. Keyed, hex or square shaped bores available on request. Bore diameters 6mm up to 30mm.



Quick Release Universal Joints

Quick change mechanism one end of the joint to allow rapid connection and release of the shaft, ideal when time is critical. Bore diameters 8mm up to 30mm.



Universal Joint Bellows

Available for both single and double universal joints, bellows are used to cover and protect the joints. Available to protect joints up to 58mm outside diameter.



Telescopic Universal Joints

Two universal joints connected by a sliding splined shaft with the ability to extend, allowing adjustments in length during installation. Bore diameters 10mm up to 30mm.



When one single joint is coupled with two shafts (of which the driving one is rotating at a constant speed) forming an angle, a periodic variation of the driven shaft is caused with exactly four fluctuations per revolution.

The difference between the maximum and the minimum speed of the driven shaft depends on the angle formed by the two shafts. The difference grows with the an increase of the angle a° . To have a homokinetic transmission, either two opposite single joints (ensuing that that the two central yokes lie on the same plane and the angles are equal) or a double joint need to be fitted. The irregularity caused by the former articulation is cancelled by the latter. The overall length resulting from the coupling of the two single joints can be reduced by using a double joint. In other words, the double joint is to be considered as the shortest homokinetic transmission.

For low speed applications (Max. 1000 rpm), joints with plain bearings (rubbing bearings) are suggested. They are able to support shock loads, motion reversals, irregular runnings and relatively high torques. The working angles must be restricted when using at speeds between 500 - 1000 rpm. Please consult our technical department if you have such an application.

For high rotation speeds, relatively low torques or wide angles, joints with needle roller bearings are preferred. They can reach 4000 RPM dependent on the angle.

Dynamic basic load ratings of plain bearing rod ends

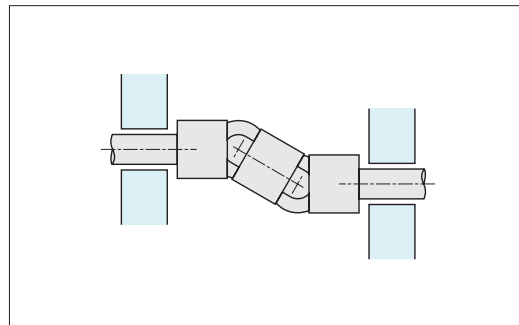
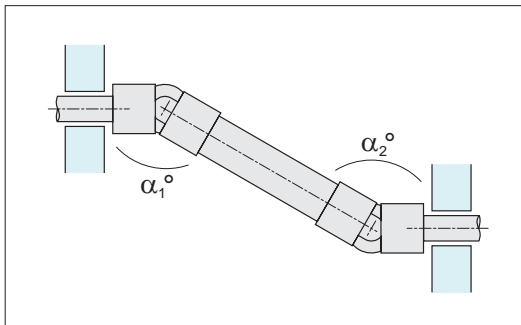

To obtain a uniform rotary motion always use either two opposite single joints or one double joints.
 $\alpha_1 = \alpha_2$.

The pillow block supports should be positioned as close as possible to the joints.

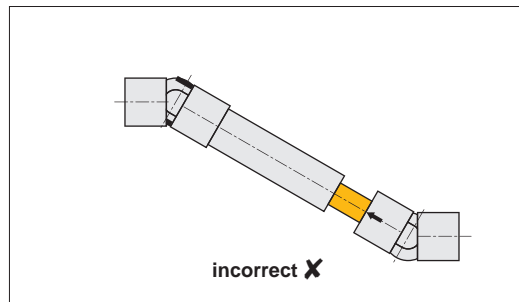
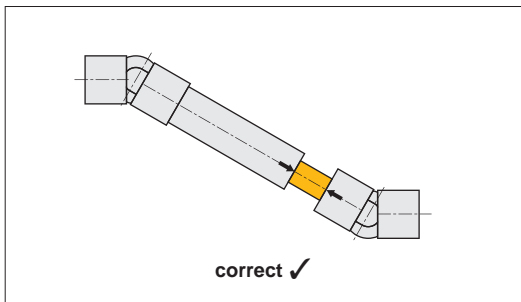

When using two opposite single joints ensure the alignment of the inside yokes.

In extensible transmissions make sure that the arrows are perfectly aligned.

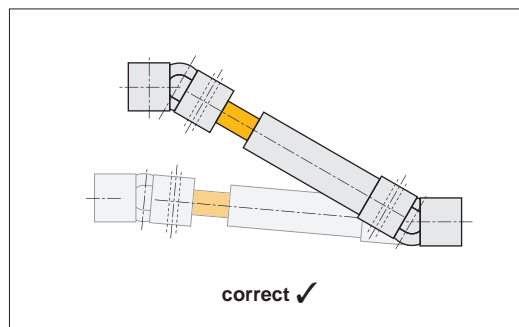
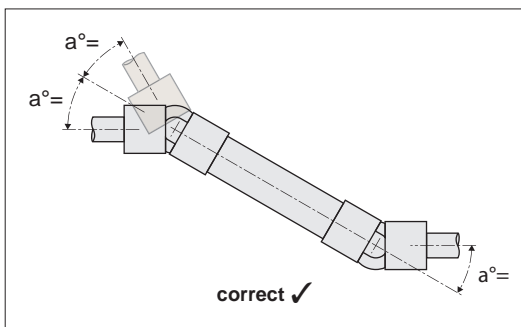

It is essential that the two bending angles a° are equal.

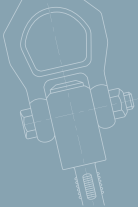

How to read diagrams

The joint capacity to transmit a regular torque at a constant load with no shocks, for a long period, mainly depends on the number of revolutions per minute and the inclination angle a° of the two axes. The diagrams on the following pages are based on this. Each curve corresponds to the joint size (outside diameter "D") and represents the torque that the joint can transmit depending on speed and working angle a° .

The diagrams can be directly read if angle (a°) is 10° . For wider angles, torques are reduced, therefore these are to be corrected using the correction vales (F) relating to the angle shown in the table.

Important Note: Diagrams' values are merely indicative and refer to the single joints only. When choosing a double joint, you have to consider that they can transmit a torque about 10% lower than the same sized single joints. Each application has its own particular motion characteristics, such as: shock loads, motion reversals, connected masses, kind of starting, presence of elastic joints, stops and starts, etc., that have to be considered when choosing the joint.

Working angle a°	Correction value F
5°	1,25
10°	1,00
15°	0,80
20°	0,65
25°	0,55
30°	0,45
35°	0,38
40°	0,30
45°	0,25

Example

Known: Power = 0,65 kW
RPM = 230

With working angle a 10° , F = 1, we get point **P**. Torque = 27 Nm corresponding to joint size "D" = 25/26mm = Types **65170.W0016** and **65172.W0012**

With working angle a 30° , F = 0,45 (kW 0,65: 0,45 = 1,44 kW) we get point **P1** Torque = 60 Nm corresponding to joint size "D" = 32mm = Types **65170.W0020** and **65172.W0016**

Consider that:

$$\text{Torque in Nm} = 9550 \times \frac{\text{Power (kW)}}{\text{RPM}}$$

$$\text{Torque in Nm} = 7020 \times \frac{\text{Power (HP)}}{\text{RPM}}$$

- 1 kW = 1,35 HP
- 1 HP = 0,736 kW
- 1 Kgm = 9,81 Nm
- 1 Nm = 0,102 Kgm



Torque Ratings for Plain Bearing Universal Joints



Materials Handling

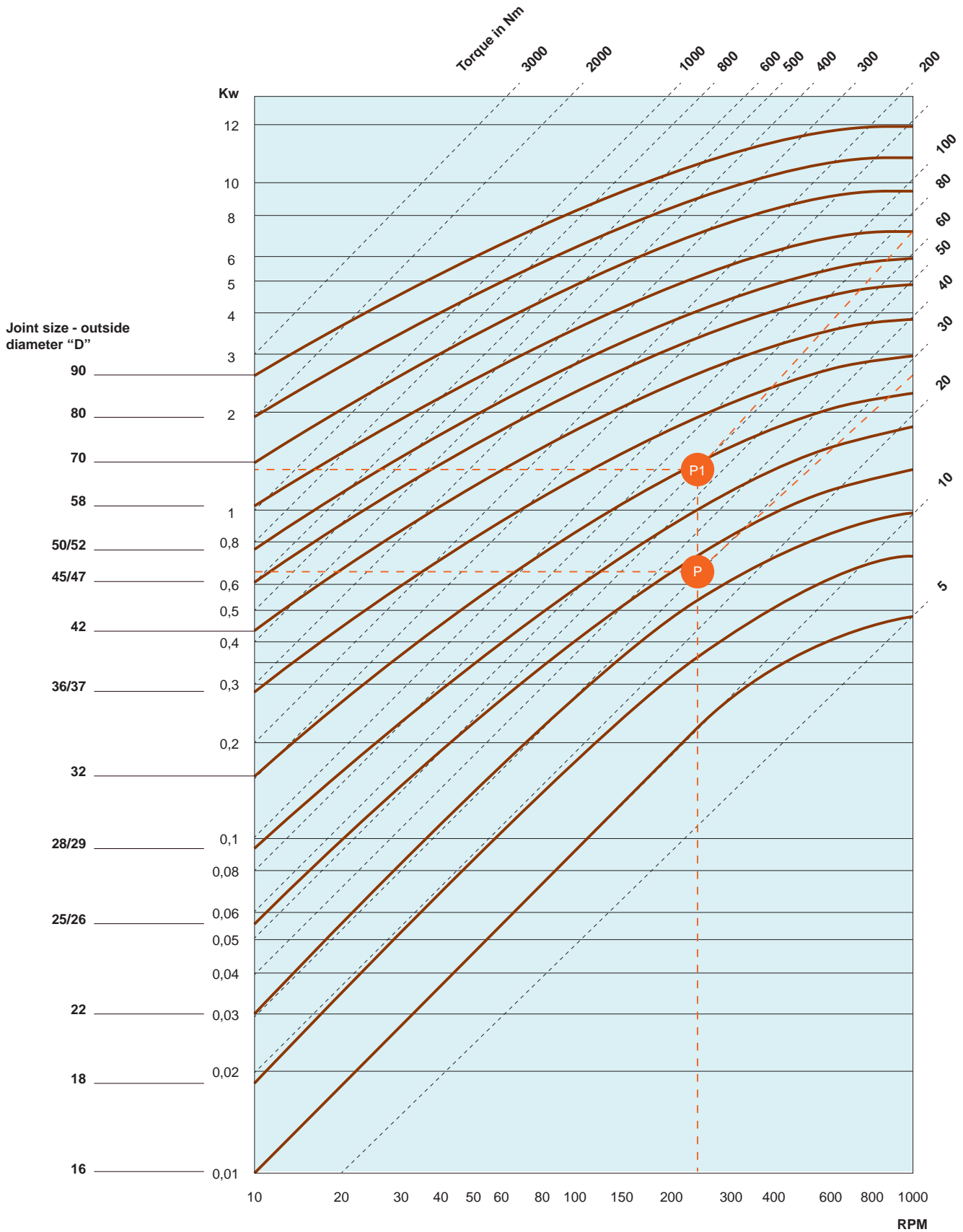

UNIVERSAL JOINTS

ov-W65142-AR3680-T-W65282-A-T-d-rmh-Updated -31-10-2022

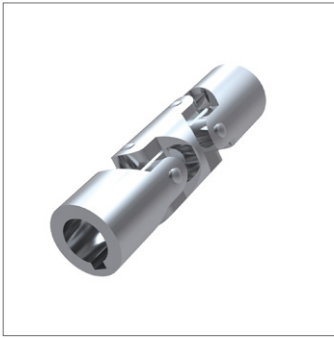

65160

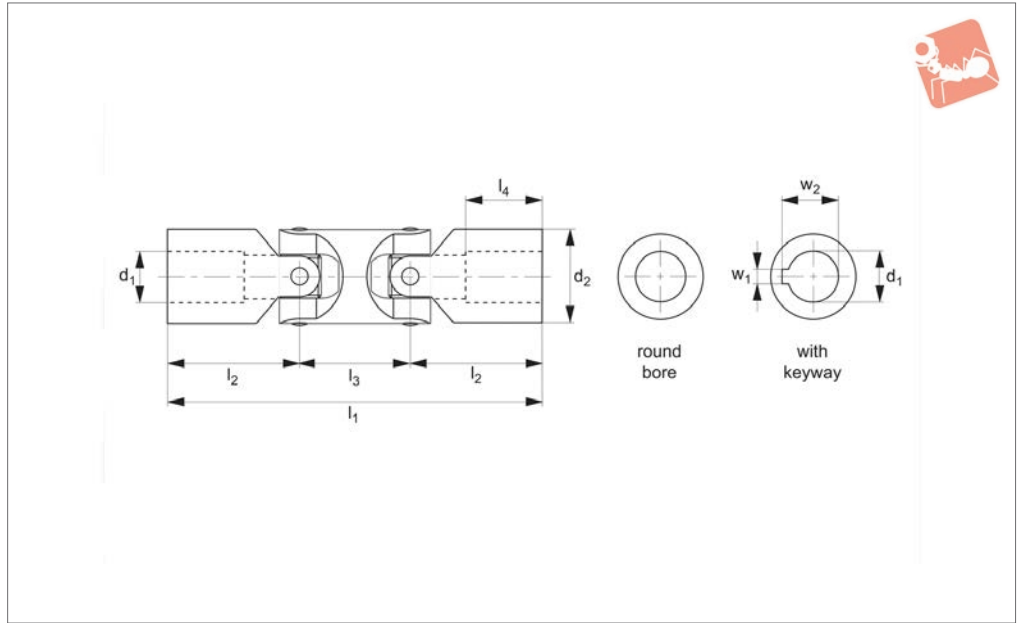

Material

Steel (9 SMnPb28k, no. 10718).

Bearing type: Plain bearing.

Technical Notes

To DIN 808/7551, keyways aligned.

Maximum bending angle 45° per joint.

Max. drive speed of 1000 rpm.

Tips

Double universal joints are used where large bending angles are required or where

two shafts offset in relation to each other.

Product variations available on request, for square bores change the suffix to SQ for square bores or HX for hex bores.

For stainless steel see 65166.

Order No.	Bore dia.	d ₁ tol. H7	d ₂	l ₁	l ₂	l ₃	l ₄	w ₁ tol. JS9	w ₂	Weight g
65160.W0010	Round bore	10	16	74	26	22	15	-	-	80
65160.W0012	Round Bore	12	22	88	31	26	18	-	-	200
65160.W0016	Round Bore	16	25	104	37	30	21	-	-	300
65160.W0020	Round Bore	20	32	124	43	38	24	-	-	500
65160.W0025	Round Bore	25	42	156	54	48	31	-	-	1200
65160.W0030	Round Bore	30	50	188	66	56	38	-	-	1700
65160.W0040	Round Bore	40	70	238	83	72	47	-	-	4300
65160.W0210	with keyway	10	16	74	26	22	15	3	11.4	80
65160.W0212	with keyway	12	22	88	31	26	18	4	13.8	200
65160.W0216	with keyway	16	25	104	37	30	21	5	18.3	300
65160.W0220	with keyway	20	32	124	43	38	24	6	22.8	500
65160.W0225	with keyway	25	42	156	54	48	31	8	28.3	1200
65160.W0230	with keyway	30	50	188	66	56	38	8	33.3	1700
65160.W0240	with keyway	40	70	238	83	72	47	12	43.3	4300



Double Universal Joint

Steel

Universal Joints

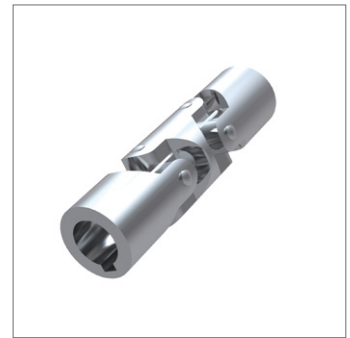
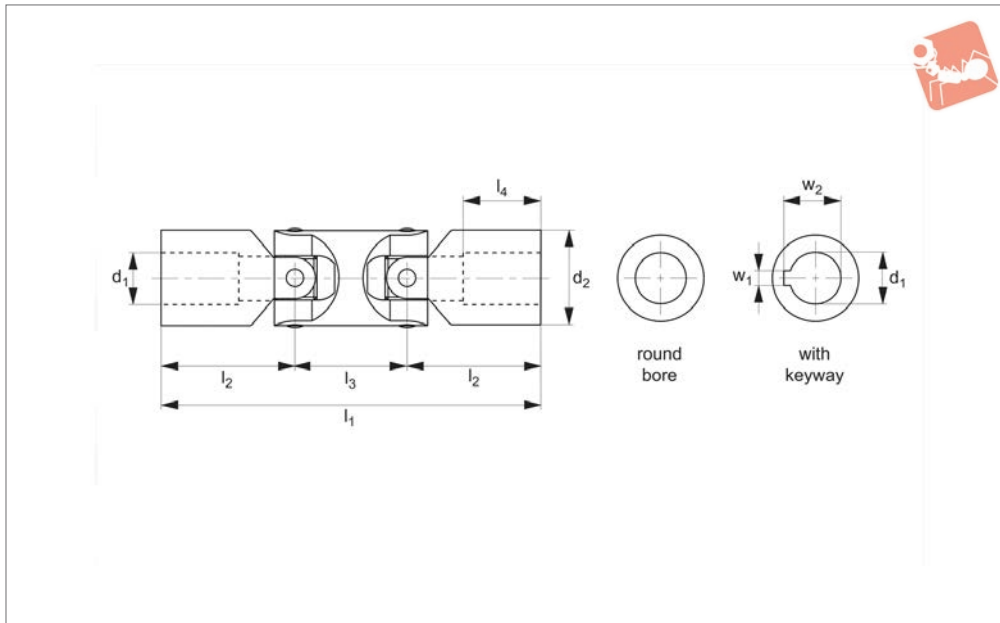

65162

UNIVERSAL JOINTS

Material

Steel (9SMnPb28k, no. 10718).
Bearing type: Plain bearing.

Technical Notes

To DIN 808, keyways aligned.
Maximum bending angle 45° per joint.

Max. drive speed of 1000 rpm.

Tips

Double universal joints are used where large bending angles are required or where two shafts offset in relation to each other.
Product variations available on request, for

square bores change the suffix to SQ for square bores or HX for hex bores.

For stainless steel see part number 65166, for needle roller bearings see part number

Order No.	Bore dia.	d ₁ tol. H7	d ₂	l ₁	l ₂	l ₃	l ₄	w ₁ tol. JS9	w ₂	Weight g
65162.W0006	Round bore	6	16	56	17.0	22	8	-	-	80
65162.W0008	Round Bore	8	16	62	20.0	22	11	-	-	80
65162.W0010	Round Bore	10	22	74	24.0	26	12	-	-	150
65162.W0012	Round Bore	12	25	86	28.0	30	13	-	-	250
65162.W0014	Round Bore	14	28	96	30.0	36	14	-	-	400
65162.W0016	Round Bore	16	32	104	34.0	36	16	-	-	450
65162.W0018	Round Bore	18	36	114	37.0	40	17	-	-	700
65162.W0020	Round Bore	20	42	128	41.0	46	18	-	-	1000
65162.W0022	Round Bore	22	45	145	47.5	50	22	-	-	1550
65162.W0025	Round Bore	25	50	163	54.0	55	26	-	-	2000
65162.W0030	Round Bore	30	58	190	61.0	68	29	-	-	2900
65162.W0032	Round Bore	32	58	198	65.0	68	33	-	-	3000
65162.W0035	Round Bore	35	70	212	70.0	72	35	-	-	4750
65162.W0040	Round Bore	40	80	245	80.0	85	39	-	-	7200
65162.W0050	Round Bore	50	95	290	95.0	100	46	-	-	12.000
65162.W0206	With keyway	6	16	56	17.0	22	8	2	7	80
65162.W0208	With Keyway	8	16	62	20.0	22	11	2	9	80
65162.W0210	With Keyway	10	22	74	24.0	26	12	3	11.4	150
65162.W0212	With Keyway	12	25	86	28.0	30	13	4	13.8	250
65162.W0214	With Keyway	14	28	96	30.0	36	14	5	16.3	400
65162.W0216	With Keyway	16	32	104	34.0	36	16	5	18.3	450
65162.W0218	With Keyway	18	36	114	37.0	40	17	6	20.8	700
65162.W0220	With Keyway	20	42	128	41.0	46	18	6	22.8	1000
65162.W0222	With Keyway	22	45	145	47.5	50	22	6	24.8	1550
65162.W0225	With Keyway	25	50	163	54.0	55	26	8	28.3	2000
65162.W0230	With Keyway	30	58	190	61.0	68	29	8	33.3	2900
65162.W0232	With Keyway	32	58	198	65.0	68	33	10	35.3	3000
65162.W0235	With Keyway	35	70	212	70.0	72	35	10	38.3	4750
65162.W0240	With Keyway	40	80	245	80.0	85	39	12	43.3	7200
65162.W0250	With Keyway	50	95	290	95.0	100	46	14	53.8	12.000



UNIVERSAL JOINTS



65166

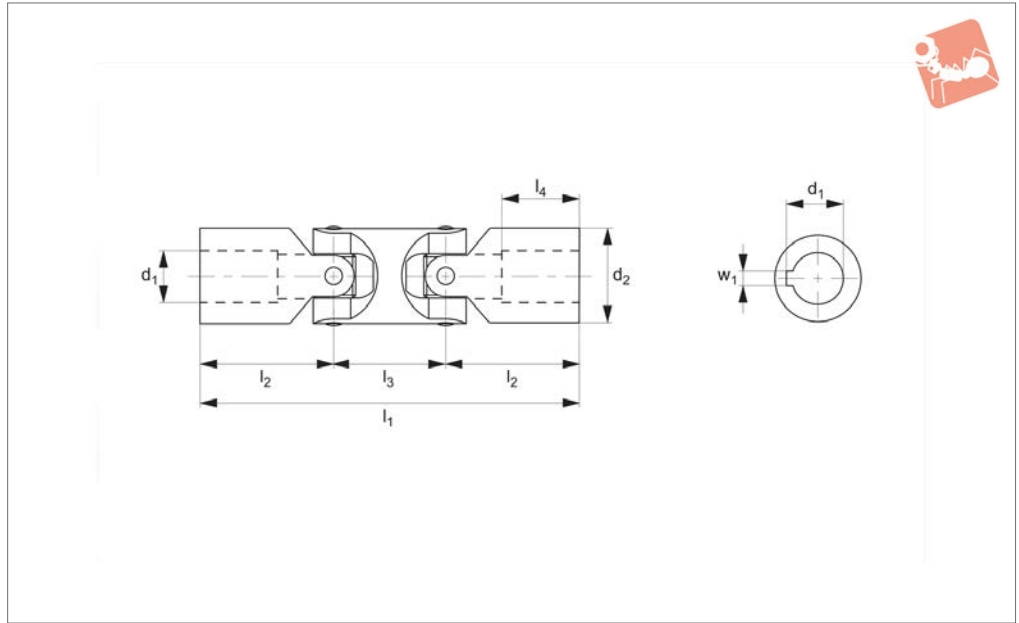

Material

Stainless steel (AISI 304).

per joint.

square bores or HX for hex bores.

Technical Notes

To DIN 808, maximum bending angle 45°

Tips

Product variations available on request, for square bores change the suffix to SQ for

Order No.	Bore dia.	d ₁ tol. H7	d ₂	l ₁	l ₂	l ₃	l ₄	w ₁	w ₂	Weight g
65166.W0020	Round Bore	20	42	128	41	46	18	-	-	1000
65166.W0025	Round Bore	25	50	163	54	55	26	-	-	2000
65166.W0220	Keyway	20	42	128	41	46	18	6	22.8	1000

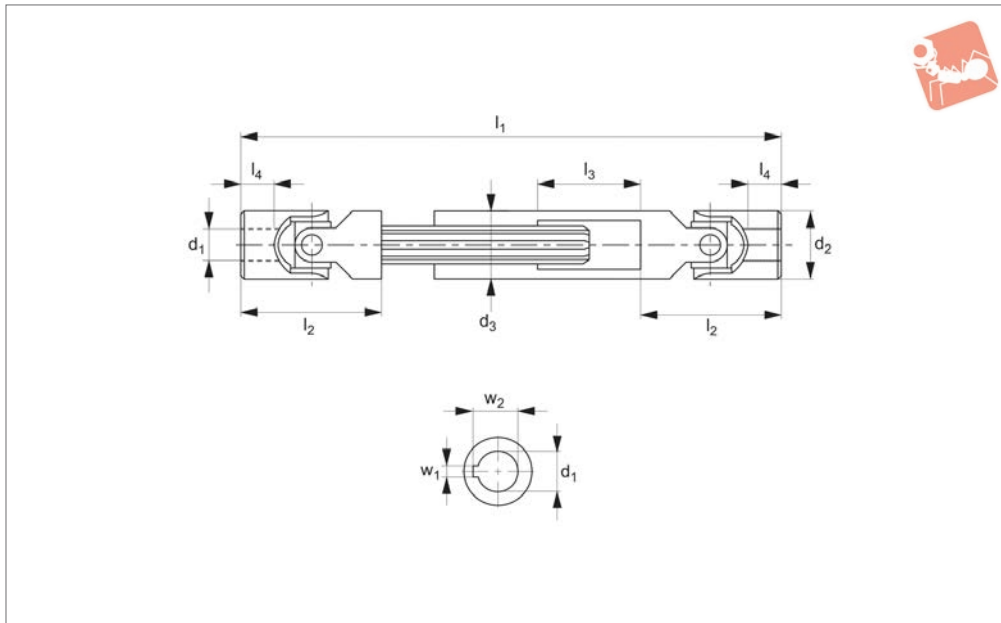

65142

UNIVERSAL JOINTS

Material

Steel (9SMnPb28k, no. 10718, greased).
Bearing type: plain bearing.

Maximum bending angle 45° per joint. The drive speed of universal joints with journal bearings must not exceed 1000 rpm.

Tips

Double universal joints are used where large bending angles are required or where two shafts offset in relation to each other. Zinc plated available on request.

Technical Notes

To DIN 808.

Order No.	d ₁ tol. H7	d ₂	d ₃	l ₁ min.	l ₁ max.	l ₂	l ₃ stroke	l ₄	w ₁ tol. JS9	w ₂	Shaft	Weight g
65142.W2100	10	22	22	140	170	48	30	12	3	11.4	11x14x6	310
65142.W2101	10	22	22	160	200	48	40	12	3	11.4	11x14x6	360
65142.W2102	10	22	22	180	240	48	60	12	3	11.4	11x14x6	380
65142.W2103	10	22	22	230	330	48	100	12	3	11.4	11x14x6	500
65142.W2120	12	25	26	160	190	56	30	13	4	13.8	13x16x6	500
65142.W2121	12	25	26	180	225	56	45	13	4	13.8	13x16x6	560
65142.W2122	12	25	26	200	270	56	70	13	4	13.8	13x16x6	620
65142.W2123	12	25	26	220	300	56	80	13	4	13.8	13x16x6	670
65142.W2124	12	25	26	250	355	56	105	13	4	13.8	13x16x6	760
65142.W2125	12	25	26	280	420	56	140	13	4	13.8	13x16x6	840
65142.W2126	12	25	26	300	450	56	150	13	4	13.8	13x16x6	900
65142.W2140	14	28	29	170	200	60	30	14	5	16.3	13x16x6	620
65142.W2141	14	28	29	180	220	60	40	14	5	16.3	13x16x6	640
65142.W2142	14	28	29	200	260	60	60	14	5	16.3	13x16x6	720
65142.W2143	14	28	29	220	300	60	80	14	5	16.3	13x16x6	780
65142.W2144	14	28	29	250	350	60	100	14	5	16.3	13x16x6	870
65142.W2145	14	28	29	280	420	60	140	14	5	16.3	13x16x6	960
65142.W2146	14	28	29	300	450	60	150	14	5	16.3	13x16x6	1030
65142.W2147	14	28	29	350	550	60	200	14	5	16.3	13x16x6	1170
65142.W2148	14	28	29	400	650	60	250	14	5	16.3	13x16x6	1330
65142.W2160	16	32	32	190	220	68	30	16	5	18.3	16x20x6	900
65142.W2161	16	32	32	210	250	68	40	16	5	18.3	16x20x6	980
65142.W2162	16	32	32	240	320	68	80	16	5	18.3	16x20x6	1100
65142.W2163	16	32	32	250	350	68	100	16	5	18.3	16x20x6	1140
65142.W2164	16	32	32	275	390	68	115	16	5	18.3	16x20x6	1240
65142.W2165	16	32	32	300	430	68	130	16	5	18.3	16x20x6	1330
65142.W2166	16	32	32	380	590	68	210	16	5	18.3	16x20x6	1600
65142.W2167	16	32	32	400	630	68	230	16	5	18.3	16x20x6	1730
65142.W2180	18	36	37	230	280	74	50	17	6	20.8	18x22x6	1350
65142.W2181	18	36	37	250	320	74	70	17	6	20.8	18x22x6	1460
65142.W2182	18	36	37	270	370	74	100	17	6	20.8	18x22x6	1550
65142.W2183	18	36	37	290	400	74	110	17	6	20.8	18x22x6	1660



UNIVERSAL JOINTS

Order No.	d ₁ tol. H7	d ₂	d ₃	l ₁ min.	l ₁ max.	l ₂	l ₃ stroke	l ₄	w ₁ tol. JS9	w ₂	Shaft	Weight g
65142.W2184	18	36	37	300	415	74	115	17	6	20.8	18x22x6	1710
65142.W2185	18	36	37	400	620	74	220	17	6	20.8	18x22x6	2230
65142.W2186	18	36	37	500	820	74	320	17	6	20.8	18x22x6	2750
65142.W2303	30	58	58	400	510	122	110	29	8	33.3	32x38x8	5850
65142.W2304	30	58	58	450	620	122	170	29	8	33.3	32x38x8	6480
65142.W2305	30	58	58	500	720	122	220	29	8	33.3	32x38x8	7140
65142.W2306	30	58	58	540	795	122	255	29	8	33.3	32x38x8	7690
65142.W2202	20	42	42	290	380	82	90	18	6	22.8	21x25x6	2250
65142.W2206	20	42	42	500	800	82	300	18	6	22.8	21x25x6	3660
65142.W2253	25	50	52	380	500	108	120	26	8	28.3	26x32x6	4200
65142.W2222	22	45	47	290	350	95	60	22	6	24.8	23x28x6	2670
65142.W2300	30	58	58	330	380	122	50	29	8	33.3	32x38x8	4900
65142.W2254	25	50	52	420	590	108	170	26	8	28.3	26x32x6	4590
65142.W2250	25	50	52	295	345	108	50	26	8	28.3	26x32x6	3390
65142.W2223	22	45	47	330	430	95	100	22	6	24.8	23x28x6	3000
65142.W2203	20	42	42	320	440	82	120	18	6	22.8	21x25x6	2460
65142.W2200	20	42	42	250	300	82	50	18	6	22.8	21x25x6	1990
65142.W2301	30	58	58	350	420	122	70	29	8	33.3	32x38x8	5170
65142.W2204	20	42	42	380	560	82	180	18	6	22.8	21x25x6	2860
65142.W2255	25	50	52	460	660	108	200	26	8	28.3	26x32x6	4980
65142.W2220	22	45	47	250	280	95	30	22	6	24.8	23x28x6	2350
65142.W2251	25	50	52	310	375	108	65	26	8	28.3	26x32x6	3520
65142.W2224	22	45	47	350	470	95	120	22	6	24.8	23x28x6	3160
65142.W2256	25	50	52	500	745	108	245	26	8	28.3	26x32x6	5370
65142.W2205	20	42	42	420	640	82	220	18	6	22.8	21x25x6	3130
65142.W2252	25	50	52	350	450	108	100	26	8	28.3	26x32x6	3920
65142.W2302	30	58	58	370	455	122	85	29	8	33.3	32x38x8	5420
65142.W2221	22	45	47	270	320	95	50	22	6	24.8	23x28x6	2510
65142.W2201	20	42	42	270	340	82	70	18	6	22.8	21x25x6	2120
65142.W2225	22	45	47	470	710	95	240	22	6	24.8	23x28x6	4130

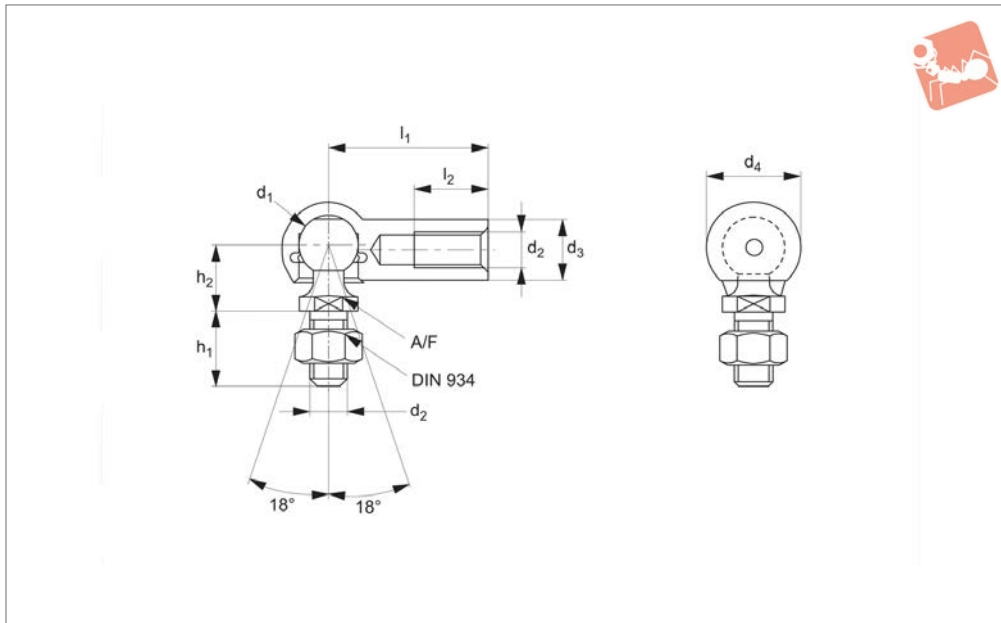

65500

BALL AND SOCKET JOINTS

Material

Steel, silver zinc plated, ball stud: minimum tensile strength $R_m=600N/mm^2$.
Housing: minimum tensile strength $R_m=500N/mm^2$.

hexagon nut.

Safety ring aids the retention of the ball stud in the housing.

*M14x1,5 is a fine pitch thread.

Important Notes

Thread is not full length. There is a min 1.5mm unthreaded shank. If using part without the supplied nut, then please consider a counterbore to accommodate the unthreaded shank.

Technical Notes

To DIN 71802 form CS, supplied with

Tips

For sealing cap version, see .

Standard thread is right hand, (for left hand thread see 65502).

Order No.	Thread hand	d ₁	l ₁ ±0.3	d ₂	d ₃	d ₄	h ₁ ±0.3	Weight g
65500.W0105	Right	8	22	M 5	8	12.8	10.2	15.2
65500.W0106	Right	10	25	M 6	10	14.8	12.5	25.2
65500.W0108	Right	13	30	M 8	13	19.3	16.5	53.1
65500.W0110	Right	16	35	M10	16	24.0	20.0	103.8
65500.W0112	Right	16	35	M12	16	24.0	20.0	103.8
65500.W0114	Right	19	45	M14x1,5*	22	30.0	28.0	220.9
65500.W0115	Right	19	45	M14	22	30.0	28.0	220.9
65500.W0116	Right	19	45	M16	22	30.0	28.0	220.9

Order No.	h ₂ ±0.3	l ₂ min.	A/F tol. h14	Extraction force kg min.	Static load kg max.	Dyn. load C kg max.	Force required for movement kg max.
65500.W0105	9	10.2	7	3	50	20	3
65500.W0106	11	11.5	8	4	100	40	4
65500.W0108	13	14.0	11	6	200	80	6
65500.W0110	16	15.5	13	8	400	160	8
65500.W0112	16	15.5	13	8	400	160	8
65500.W0114	22	21.5	16	10	800	320	10
65500.W0115	22	21.5	16	10	800	320	10
65500.W0116	22	21.5	16	10	800	320	10



65502

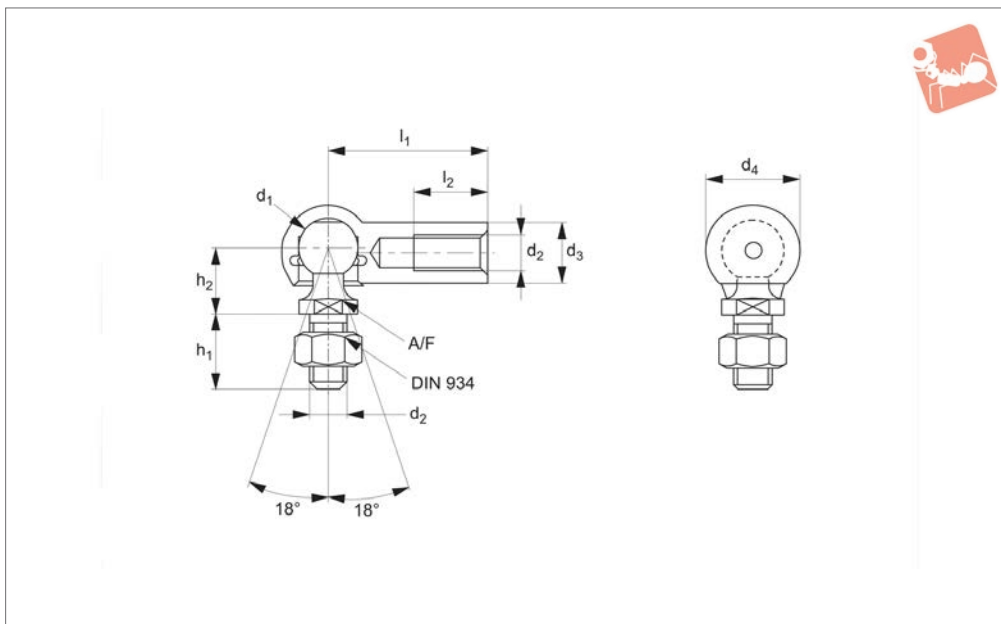

Material

Steel, silver zinc plated, ball stud: minimum tensile strength $R_m=600N/mm^2$.
Housing: minimum tensile strength $R_m=500N/mm^2$.

hexagon nut.

Safety ring aids the retention of the ball stud in the housing.

*M14x1,5 is a fine pitch thread.

Important Notes

Thread is not full length. There is a min 1.5mm unthreaded shank. If using part without the supplied nut, then please consider a counterbore to accommodate the unthreaded shank.

Technical Notes

To DIN 71802 form CS, supplied with

Tips

Stud: right hand thread.

Housing: left hand thread.

For sealing cap version, see .

Order No.	Thread hand	d_1	l_1 ± 0.3	d_2	d_3	d_4	h_1 ± 0.3	Weight g
65502.W0005	Left	8	22	M 5	8	12.8	10.2	15.2
65502.W0006	Left	10	25	M 6	10	14.8	12.5	25.2
65502.W0008	Left	13	30	M 8	13	19.3	16.5	53.1
65502.W0010	Left	16	35	M10	16	24.0	20.0	103.8
65502.W0012	Left	16	35	M12	16	24.0	20.0	103.8
65502.W0014	Left	19	45	M14x1,5*	22	30.0	28.0	220.9
65502.W0015	Left	19	45	M14	22	30.0	28.0	220.9
65502.W0016	Left	19	45	M16	22	30.0	28.0	220.9

Order No.	h_2 ± 0.3	l_2 min.	A/F tol. h14	Extraction force kg min.	Static load kg max.	Dyn. load C kg max.	Force required for movement kg max.
65502.W0005	9	10.2	7	3	50	20	3
65502.W0006	11	11.5	8	4	100	40	4
65502.W0008	13	14.0	11	6	200	80	6
65502.W0010	16	15.5	13	8	400	160	8
65502.W0012	16	15.5	13	8	400	160	8
65502.W0014	22	21.5	16	10	800	320	10
65502.W0015	22	21.5	16	10	800	320	10
65502.W0016	22	21.5	16	10	800	320	10



Ball and Socket Joint with flats on housing

Ball and Socket Joints

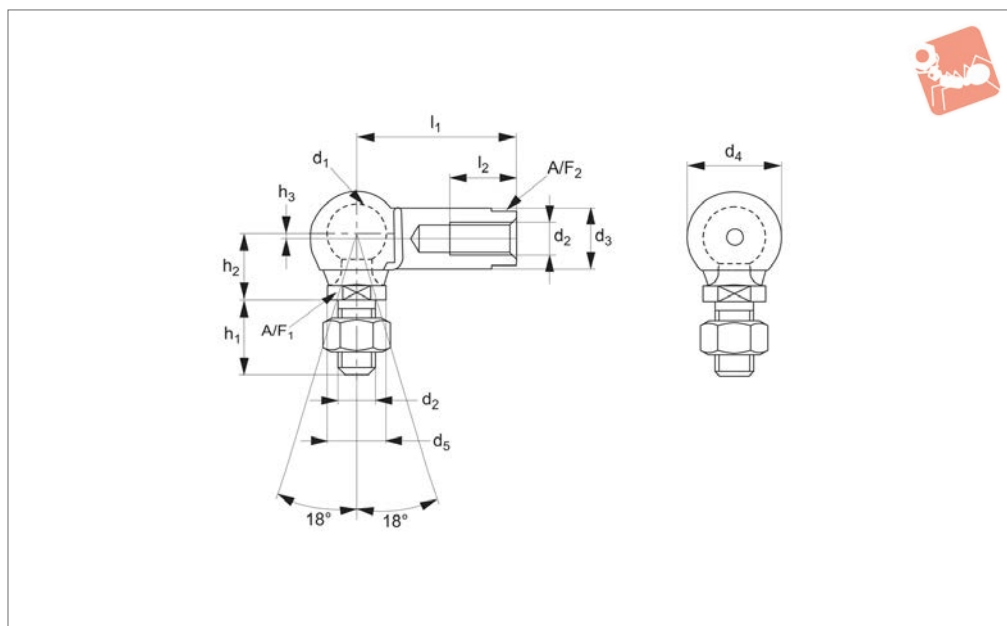

65508

BALL AND SOCKET JOINTS

Material

Stud: carbon steel, sealing cap: neoprene.
Housing: steel (9sMnPb28), silver zinc plated.

Technical Notes

To DIN 71802 form CS, supplied without hexagon nut.

Safety ring aids the retention of the ball stud in the housing.

*M14x1,5 is a fine pitch thread.

Tips

Standard thread is right hand, (for left hand thread see 65510).

Important Notes

Thread is not full length. There is a min 1.5mm unthreaded shank. If using part without a nut, then please consider a counterbore to accommodate the unthreaded shank.

Order No.	Thread hand	d ₁	l ₁ ±0.3	d ₂	d ₃ ±0.5	d ₄ ±0.5	d ₅ ±0.5	Weight g
65508.W0105	Right	8	22	M 5	8	12.8	8	15.2
65508.W0106	Right	10	25	M 6	10	14.8	10	25.2
65508.W0108	Right	13	30	M 8	13	19.3	13	53.1
65508.W0110	Right	16	35	M10	16	24.0	16	103.8
65508.W0112	Right	16	35	M12	16	24.0	16	103.8
65508.W0114	Right	19	45	M14x1,5*	22	30.0	22	220.9
65508.W0115	Right	19	45	M14	22	30.0	22	220.9
65508.W0116	Right	19	45	M16	22	30.0	22	220.9

Order No.	h ₁ ±0.3	h ₂ ±0.3	h ₃	l ₂ min.	A/F ₁	A/F ₂	Extraction force kg min.	Static load kg max.	Dyn. load C kg max.	Force required for movement kg max.
65508.W0105	10.0	9	0.65	10.2	7	-	3	50	20	3
65508.W0106	12.5	11	0.70	11.5	8	-	4	100	40	4
65508.W0108	16.5	13	1.15	14.0	11	-	6	200	80	6
65508.W0110	20.0	16	1.15	15.5	13	-	8	400	160	8
65508.W0112	20.0	16	1.15	15.5	13	-	8	400	160	8
65508.W0114	28.0	20	0.50	21.5	16	19	10	800	320	10
65508.W0115	28.0	20	0.50	21.5	16	19	10	800	320	10
65508.W0116	28.0	20	0.50	21.5	16	19	10	800	320	10



65510

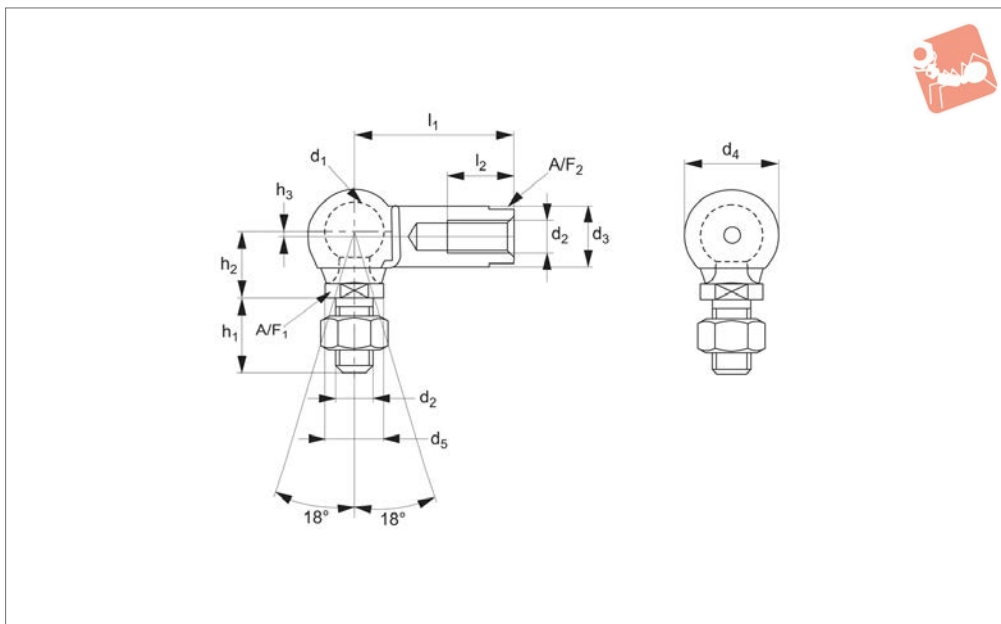

Material

Stud: carbon steel, sealing cap: neoprene.
Housing: steel (9sMnPb28), silver zinc plated.

Technical Notes

To DIN 71802 form CS, supplied with hexagon nut.

Safety ring aids the retention of the ball stud in the housing.

*M14x1,5 is a fine pitch thread.

Tips

Stud: right hand thread.

Housing: left hand thread

Important Notes

Thread is not full length. There is a min 1.5mm unthreaded shank. If using part without the supplied nut, then please consider a counterbore to accommodate the unthreaded shank.

Order No.	Thread hand	d ₁	l ₁ ±0.3	d ₂	d ₃ ±0.5	d ₄ ±0.5	d ₅ ±0.5	Weight g
65510.W0005	Left	8	22	M5	8	12.8	8	15.2
65510.W0006	Left	10	25	M6	10	14.8	10	25.2
65510.W0008	Left	13	30	M8	13	19.3	13	53.1
65510.W0010	Left	16	35	M10	16	24.0	16	103.8
65510.W0012	Left	16	35	M12	16	24.0	16	103.8
65510.W0014	Left	19	45	M14x1,5	22	30.0	22	220.9
65510.W0015	Left	19	45	M14	22	30.0	22	220.9
65510.W0016	Left	19	45	M16	22	30.0	22	220.9

Order No.	h ₁ ±0.3	h ₂ ±0.3	h ₃	l ₂ min.	A/F ₁	A/F ₂	Extraction force kg min.	Static load kg max.	Dyn. load C kg max.	Force required for movement kg max.
65510.W0005	10.0	9	0.65	10.2	7	-	3	50	20	3
65510.W0006	12.5	11	0.70	11.5	8	-	4	100	40	4
65510.W0008	16.5	13	1.15	14.0	11	-	6	200	80	6
65510.W0010	20.0	16	1.15	15.5	13	-	8	400	160	8
65510.W0012	20.0	16	1.15	15.5	13	-	8	400	160	8
65510.W0014	28.0	20	0.50	21.5	16	19	10	800	320	10
65510.W0015	28.0	20	0.50	21.5	16	19	10	800	320	10
65510.W0016	28.0	20	0.50	21.5	16	19	10	800	320	10



Parts overview

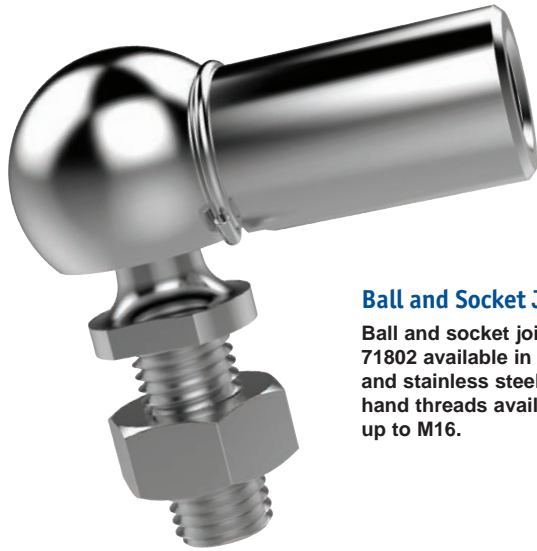

Ball and Socket Joints

Ball and socket joints to DIN 71802 available in zinc plated steel and stainless steel. Right and left hand threads available. Sizes M5 up to M16.



Axial Ball and Socket Joints

In-line ball and socket joints to DIN 71802 available in zinc plated steel and stainless steel. Sizes M5 up to M14 x 1,5.



Ball and Socket Joints with sealing caps and spanner flats

Ball and socket joints to DIN 71802 available in zinc plated steel and stainless steel. Right and left hand threads available. Spanner flats on housing to aid installation. Sizes M5 up to M16.

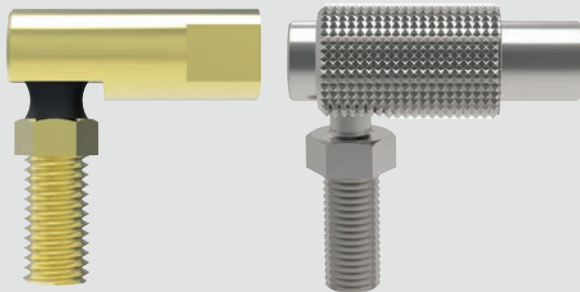

Quick Release plus other ball and socket joints

Quick release ball joints allow rapid release and reconnection of ball stud for easy installation. DMG6 and male:male ball joints and lockable also available. Sizes M5 up to M10.

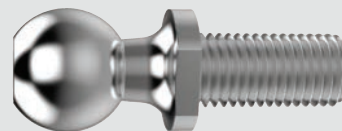

Threaded Ball Studs

Threaded ball studs to DIN71803 form C available in zinc plated steel. Sizes M5 up to M14.

see our website for our full range:
wixroyd.com



65504

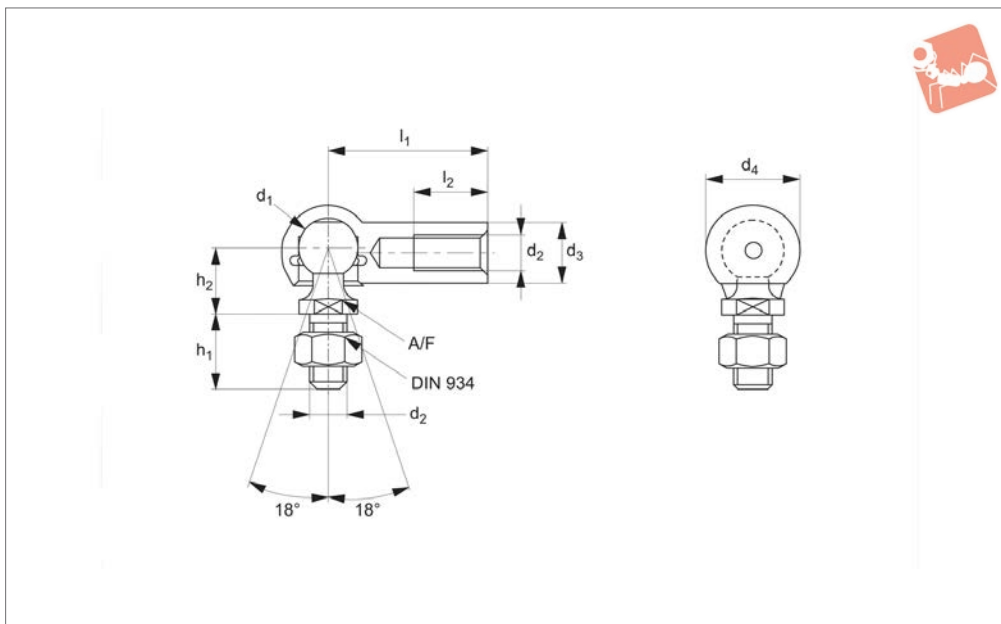

Material

Stainless steel (A2, AISI 303).

Technical Notes

To DIN 71802 form CS, supplied with hexagon nut.

Safety ring aids the retention of the ball

stud in the housing.

*M14x1,5 is a fine pitch thread.

Tips

For sealing cap version, see , standard thread is right hand, (for left hand thread see 65506).

Important Notes

Thread is not full length. There is a min 1.5mm unthreaded shank. If using part without the supplied nut, then please consider a counterbore to accommodate the unthreaded shank.

Order No.	Thread hand	d ₁	l ₁ ±0.3	d ₂	d ₃	d ₄	h ₁ ±0.3	Weight g
65504.W0005	Right	8	22	M 5	8	12.8	10.2	15.2
65504.W0006	Right	10	25	M 6	10	14.8	12.5	25.2
65504.W0008	Right	13	30	M 8	13	19.3	16.5	53.1
65504.W0010	Right	16	35	M10	16	24.0	20.0	103.8
65504.W0012	Right	16	35	M12	16	24.0	20.0	103.8
65504.W0014	Right	19	45	M14x1,5*	22	30.0	28.0	220.9
65504.W0015	Right	19	45	M14	22	30.0	28.0	220.9
65504.W0016	Right	19	45	M16	22	30.0	28.0	220.9

Order No.	h ₂ ±0.3	l ₂ min.	A/F tol. h14	Extraction force kg min.	Static load kg max.	Dyn. load C kg max.	Force required for movement kg max.
65504.W0005	9	10.2	7	3	50	20	3
65504.W0006	11	11.5	8	4	100	40	4
65504.W0008	13	14.0	11	6	200	80	6
65504.W0010	16	15.5	13	8	400	160	8
65504.W0012	16	15.5	13	8	400	160	8
65504.W0014	22	21.5	16	10	800	320	10
65504.W0015	22	21.5	16	10	800	320	10
65504.W0016	22	21.5	16	10	800	320	10



Stainless Ball and Socket Joints

left hand thread

Ball and Socket Joints

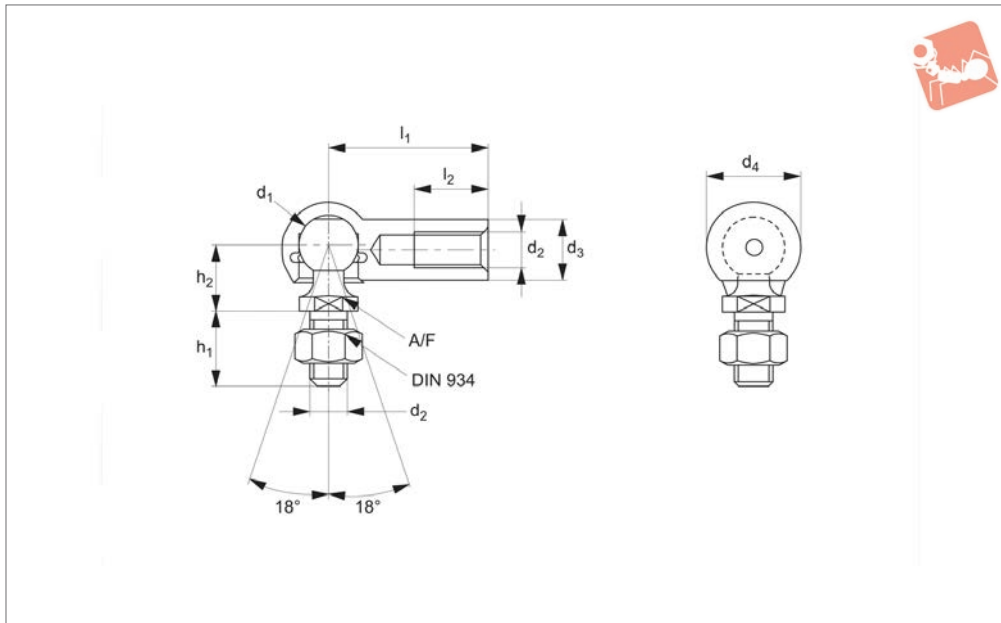

65506

BALL AND SOCKET JOINTS

Material

Stainless steel (A2, AISI 303).

Technical Notes

To DIN 71802 form CS, supplied with hexagon nut.

Safety ring aids the retention of the ball

stud in the housing.

*M14x1,5 is a fine pitch thread.

Tips

Stud: right hand thread.

Housing: left hand thread

For sealing cap version, see .

Important Notes

Thread is not full length. There is a min 1.5mm unthreaded shank. If using part without the supplied nut, then please consider a counterbore to accommodate the unthreaded shank.

Order No.	Thread hand	d ₁	l ₁ ±0.3	d ₂	d ₃	d ₄	h ₁ ±0.3	Weight g
65506.W0005	Left	8	22	M 5	8	12.8	10.2	15.2
65506.W0006	Left	10	25	M 6	10	14.8	12.5	25.2
65506.W0008	Left	13	30	M 8	13	19.3	16.5	53.1
65506.W0010	Left	16	35	M10	16	24.0	20.0	103.8
65506.W0012	Left	16	35	M12	16	24.0	20.0	103.8
65506.W0014	Left	19	45	M14x1,5*	22	30.0	28.0	220.9
65506.W0015	Left	19	45	M14	22	30.0	28.0	220.9
65506.W0016	Left	19	45	M16	22	30.0	28.0	220.9

Order No.	h ₂ ±0.3	l ₂ min.	A/F tol. h14	Extraction force kg min.	Static load kg max.	Dyn. load C kg max.	Force required for movement kg max.
65506.W0005	9	10.2	7	3	50	20	3
65506.W0006	11	11.5	8	4	100	40	4
65506.W0008	13	14.0	11	6	200	80	6
65506.W0010	16	15.5	13	8	400	160	8
65506.W0012	16	15.5	13	8	400	160	8
65506.W0014	22	21.5	16	10	800	320	10
65506.W0015	22	21.5	16	10	800	320	10
65506.W0016	22	21.5	16	10	800	320	10



65512

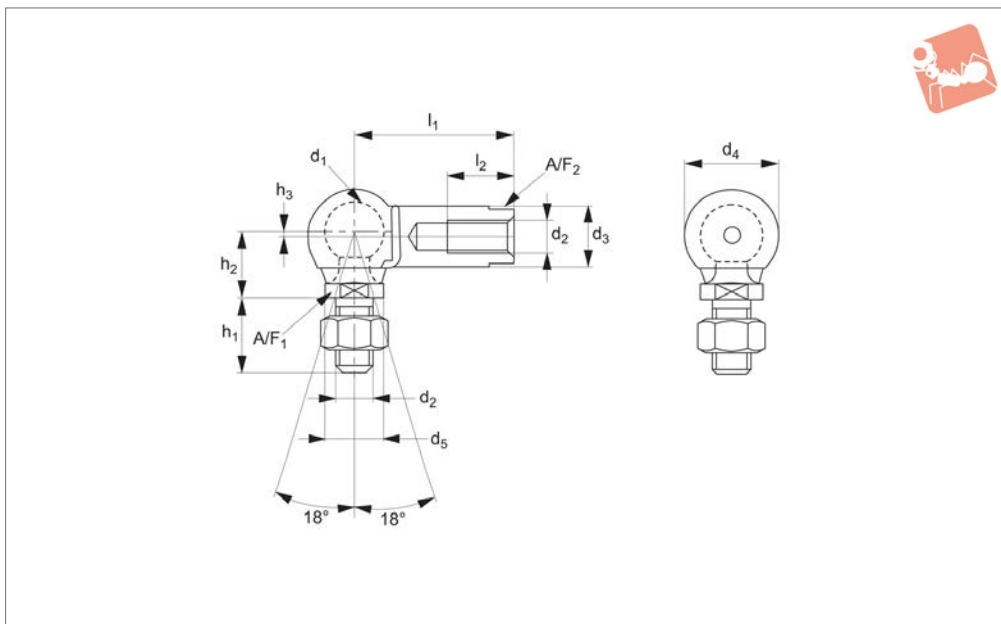

Material

Stainless steel (A2, AISI 303), sealing cap: neoprene.

Technical Notes

To DIN 71802 form CS, supplied with hexagon nut.

Safety ring aids the retention of the ball

stud in the housing.

*M14x1,5 is a fine pitch thread.

Tips

Standard thread is right hand, (for left hand thread see 65514).

Important Notes

Thread is not full length. There is a min 1.5mm unthreaded shank. If using part without the supplied nut, then please consider a counterbore to accommodate the unthreaded shank.

Order No.	Thread hand	d ₁	l ₁ ±0.3	d ₂	d ₃ ±0.5	d ₄ ±0.5	d ₅ ±0.5	h ₁ ±0.3	h ₂ ±0.3	h ₃	Weight g
65512.W0105	Right	8	22	M5	8	12.8	8	10.0	9	0.65	15.2
65512.W0106	Right	10	25	M6	10	14.8	10	12.5	11	0.70	25.2
65512.W0108	Right	13	30	M8	13	19.3	13	16.5	13	1.15	53.1
65512.W0110	Right	16	35	M10	16	24.0	16	20.0	16	1.15	103.8
65512.W0112	Right	16	35	M12	16	24.0	16	20.0	16	1.15	103.8
65512.W0114	Right	19	45	M14x1,5*	22	30.0	22	28.0	20	0.50	220.9
65512.W0115	Right	19	45	M14	22	30.0	22	28.0	20	0.50	220.9
65512.W0116	Right	19	45	M16	22	30.0	22	28.0	20	0.50	220.9

Order No.	l ₂ min.	A/F ₁	A/F ₂	Extraction force kg min.	Static load kg max.	Dyn. load C kg max.	Force required for movement kg max.
65512.W0105	10.2	7	-	3	50	20	3
65512.W0106	11.5	8	-	4	100	40	4
65512.W0108	14.0	11	-	6	200	80	6
65512.W0110	15.5	13	-	8	400	160	8
65512.W0112	15.5	13	-	8	400	160	8
65512.W0114	21.5	16	19	10	800	320	10
65512.W0115	21.5	16	19	10	800	320	10
65512.W0116	21.5	16	19	10	800	320	10



Stainless Ball and Socket Joint

left hand thread - with flats on housing

Ball and Socket Joints

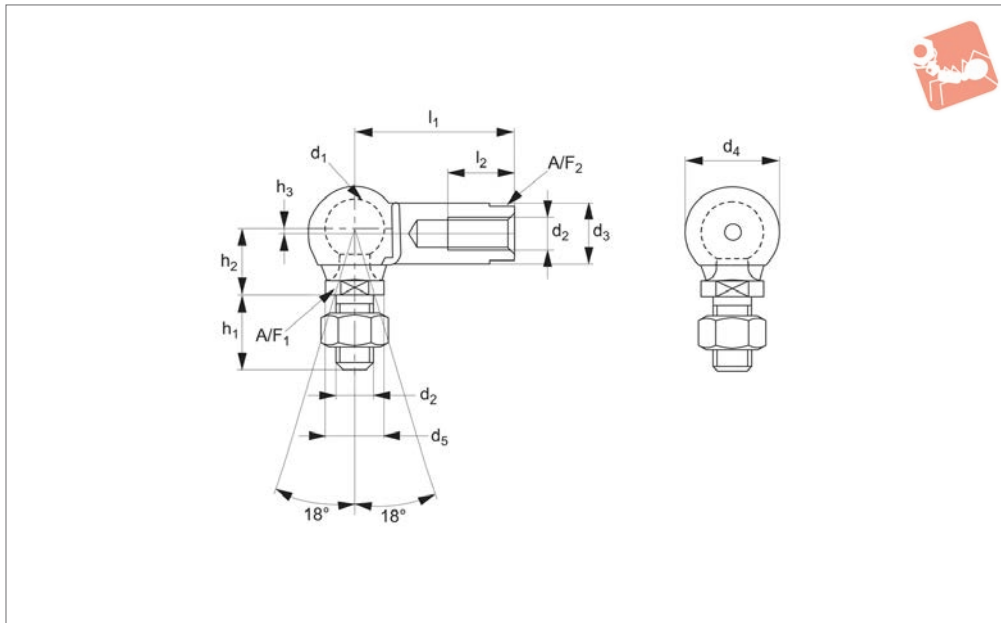

65514

BALL AND SOCKET JOINTS

Material

Stainless steel (A2, AISI 303), sealing cap: neoprene.

Technical Notes

To DIN 71802 form CS, supplied with hexagon nut.

Safety ring aids the retention of the ball stud in the housing.

*M14x1,5 is a fine pitch thread.

Tips

Stud: right hand thread.

Housing: left hand thread

Important Notes

Thread is not full length. There is a min 1.5mm unthreaded shank. If using part without the supplied nut, then please consider a counterbore to accommodate the unthreaded shank.

Order No.	Thread hand	d ₁	l ₁ ±0.3	d ₂	d ₃ ±0.5	d ₄ ±0.5	d ₅ ±0.5	h ₁ ±0.3	h ₂ ±0.3	h ₃	Weight g
65514.W0005	Left	8	22	M5	8	12.8	8	10.0	9	0.65	15.2
65514.W0006	Left	10	25	M6	10	14.8	10	12.5	11	0.70	25.2
65514.W0008	Left	13	30	M8	13	19.3	13	16.5	13	1.15	53.1
65514.W0010	Left	16	35	M10	16	24.0	16	20.0	16	1.15	103.8
65514.W0012	Left	16	35	M12	16	24.0	16	20.0	16	1.15	103.8
65514.W0014	Left	19	45	M14x1,5*	22	30.0	22	28.0	20	0.50	220.9
65514.W0015	Left	19	45	M14	22	30.0	22	28.0	20	0.50	220.9
65514.W0016	Left	19	45	M16	22	30.0	22	28.0	20	0.50	220.9

Order No.	l ₂ min.	A/F ₁	A/F ₂	Extraction force kg min.	Static load kg max.	Dyn. load C kg max.	Force required for movement kg max.
65514.W0005	10.2	7	-	3	50	20	3
65514.W0006	11.5	8	-	4	100	40	4
65514.W0008	14.0	11	-	6	200	80	6
65514.W0010	15.5	13	-	8	400	160	8
65514.W0012	15.5	13	-	8	400	160	8
65514.W0014	21.5	16	19	10	800	320	10
65514.W0015	21.5	16	19	10	800	320	10
65514.W0016	21.5	16	19	10	800	320	10



65550

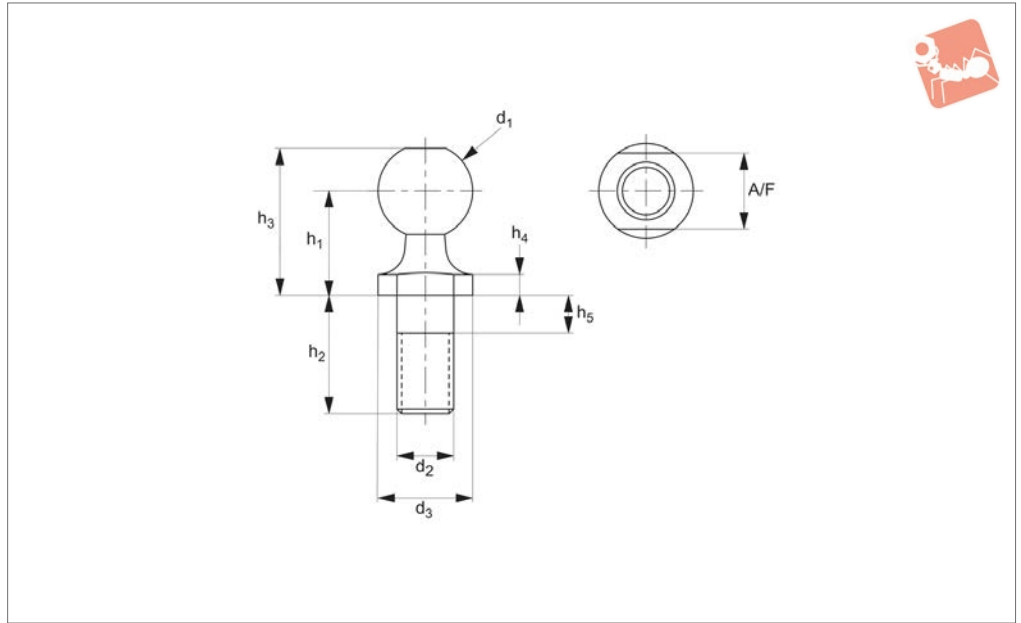

Material

Low carbon steel (1018), silver zinc plated.

Technical Notes

To DIN 71803 Form C, *M14x1.5 is a fine pitch thread.

Order No.	d_1 tol. h9	d_2	d_3 +0.0 -0.2	h_1 ± 0.3	h_2 ± 0.3	h_3 ± 0.3	h_4 +0.4 -0.0	h_5 max.	A/F	Weight g
65550.W0005	8.0	M5	8.0	9.0	10.2	12.5	2.0	4.0	7.0	4.5
65550.W0006	10.0	M6	10.0	11.0	12.5	15.5	2.2	4.0	8.0	8.5
65550.W0008	13.0	M8	13.0	13.0	16.5	18.5	2.4	5.3	11.0	17.7
65550.W0010	16.0	M10	16.0	16.0	20.0	23.0	2.7	7.3	13.0	35.0
65550.W0012	16.0	M12	16.0	16.0	20.0	23.0	2.7	7.3	13.0	35.0
65550.W0014	19.0	M14 x 1.5*	19.0	20.0	28.0	28.5	3.0	10.8	16.0	71.2
65550.W0015	19.0	M14	19.0	20.0	28.0	28.5	3.0	10.8	16.0	71.2
65550.W0016	19.0	M16	19.0	20.0	28.0	28.5	3.0	10.8	16.0	71.2

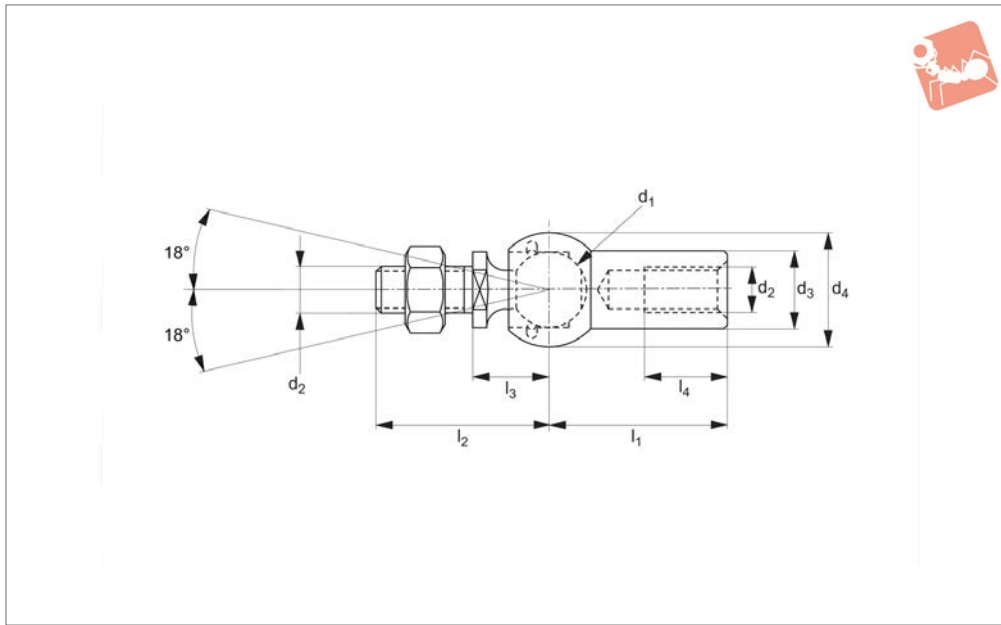

65520

BALL AND SOCKET JOINTS

Material

Steel, silver zinc plated, ball stud:
minimum tensile strength $R_m=600N/mm^2$.
Housing: minimum tensile strength
 $R_m=500N/mm^2$.

Technical Notes

Similar to DIN 71802, *M14x1,5 is a fine pitch thread.

Tips

Standard thread is right hand, (for left hand thread see 65522).
For stainless steel version see 65524.

Order No.	Thread hand	d_1 tol. h9	d_2	l_1	d_3 ± 0.5	d_4 ± 0.5	l_2	l_3	l_4	Extraction force N	Weight g
65520.W0005	Right	8	M 5	22	8	12.8	19.2	9	10.2	30	15.2
65520.W0006	Right	10	M 6	25	10	14.8	23.5	11	11.5	40	25.2
65520.W0008	Right	13	M 8	30	13	19.3	29.5	13	14.0	60	53.1
65520.W0010	Right	16	M10	35	16	24.0	36.0	16	15.5	80	103.8
65520.W0014	Right	19	M14x1,5*	45	22	30.0	48.0	20	21.5	100	220.9



65522

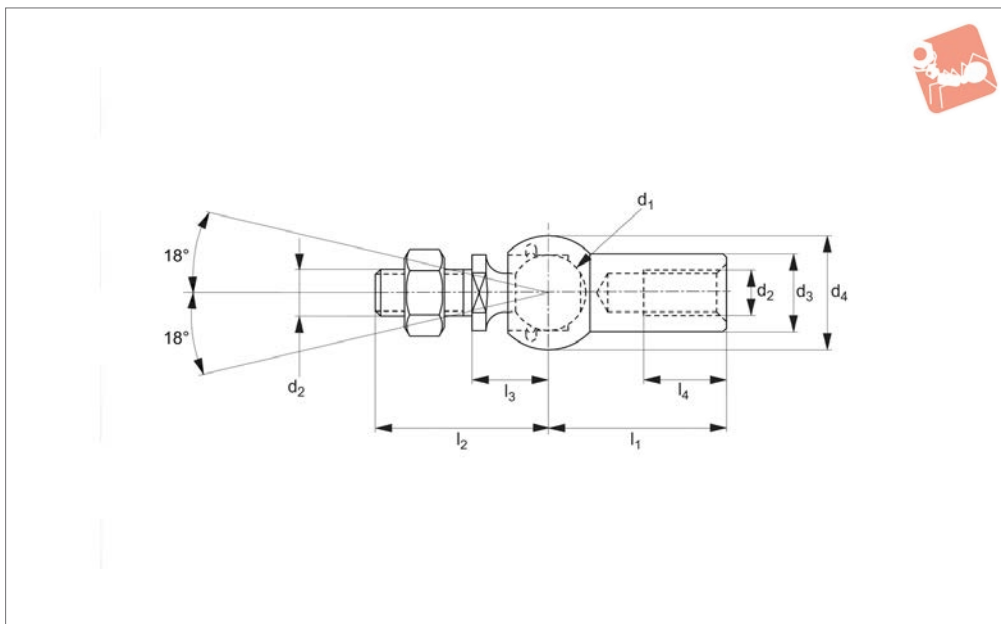

Material

Steel, silver zinc plated, ball stud:
minimum tensile strength $R_m=600N/mm^2$.
Housing: minimum tensile strength

$R_m=500N/mm^2$.

Technical Notes

Similar to DIN 71802, *M14x1,5 is a fine

pitch thread.

Tips

For stainless steel version see 65526.

Order No.	Thread hand	d_1 tol. h9	d_2	l_1	d_3 ± 0.5	d_4 ± 0.5	l_2	l_3	l_4	Extraction force N	Weight g
65522.W0005	Left	8	M5	22	8	12.8	19.2	9	10.2	30	15.2
65522.W0006	Left	10	M6	25	10	14.8	23.5	11	11.5	40	25.2
65522.W0008	Left	13	M8	30	13	19.3	29.5	13	14.0	60	53.1
65522.W0010	Left	16	M10	35	16	24.0	36.0	16	15.5	80	103.8
65522.W0014	Left	19	M14x1,5*	45	22	30.0	48.0	20	21.5	100	220.9

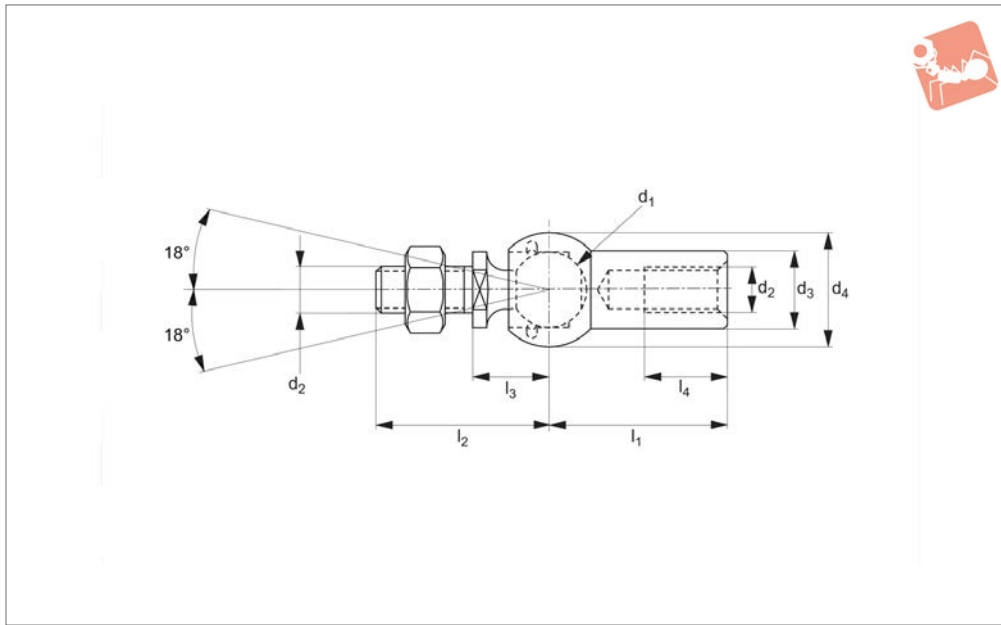

65524

BALL AND SOCKET JOINTS

Material

Stainless steel (AISI 303).

pitch thread.

Technical Notes

Similar to DIN 71802, *M14x1,5 is a fine

Tips

Standard thread is right hand, (for left hand thread see 65526).

Order No.	Thread hand	d ₁ tol. h9	d ₂	l ₁	d ₃ ±0.5	d ₄ ±0.5	l ₂	l ₃	l ₄	Extraction force N	Weight g
65524.W0005	Right	8	M5	22	8	12.8	19.2	9	10.2	30	15.2
65524.W0006	Right	10	M6	25	10	14.8	23.5	11	11.5	40	25.2
65524.W0008	Right	13	M8	30	13	19.3	29.5	13	14.0	60	53.1
65524.W0010	Right	16	M10	35	16	24.0	36.0	16	15.5	80	103.8
65524.W0014	Right	19	M14x1,5*	45	22	30.0	48.0	20	21.5	100	220.9



65526

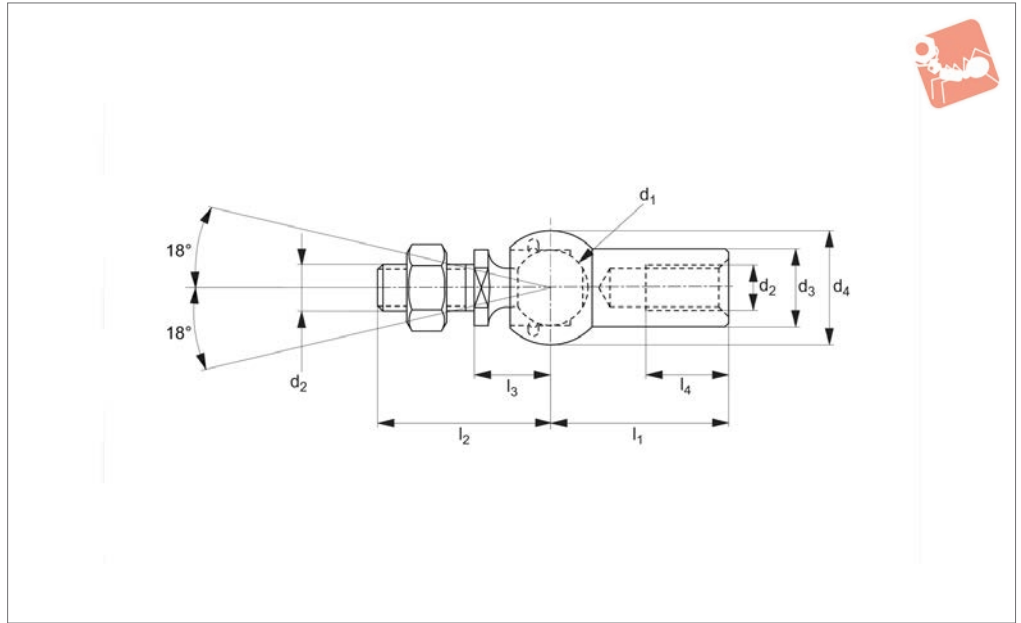

Material

Stainless steel (AISI 303).

Technical Notes

Similar to DIN 71802, *M14x1,5 is a fine pitch thread.

Order No.	Thread hand	d_1 tol. h9	d_2	l_1	d_3 ± 0.5	d_4 ± 0.5	l_2	l_3	l_4	Extraction force N	Weight g
65526.W0005	Left	8	M5	22	8	12.8	19.2	9	10.2	30	15.2
65526.W0006	Left	10	M6	25	10	14.8	23.5	11	11.5	40	25.2
65526.W0008	Left	13	M8	30	13	19.3	29.5	13	14.0	60	53.1
65526.W0010	Left	16	M10	35	16	24.0	36.0	16	15.5	80	103.8
65526.W0014	Left	19	M14x1,5*	45	22	30.0	48.0	20	21.5	100	220.9



Quick Release Ball Joints

A2 stainless and steel, zinc-plated

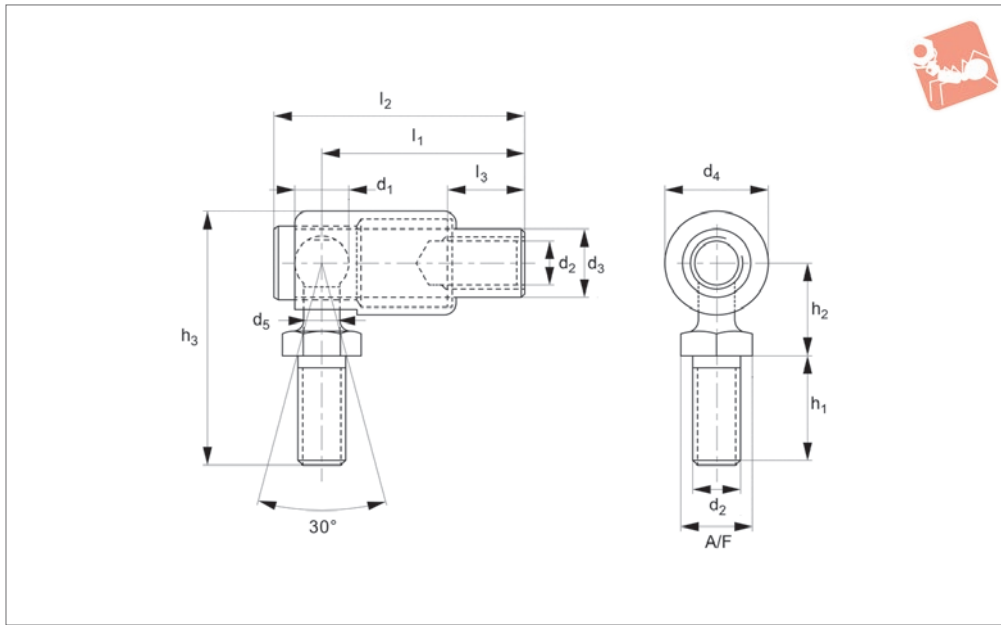
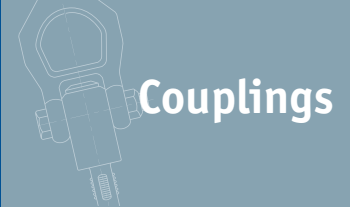

65542

COUPLINGS

Material

Body: stainless steel (A2, AISI 303) or steel zinc-plated.

Shield and ball stud: carbon steel.

Body and ball stud: case hardened.

Spring: (302 S26) stainless steel or equivalent, zinc plated.

Technical Notes

The spring loaded outer shield allows both rapid release and reconnection of the ball stud.

Linkage assemblies can be installed or removed without disturbing pre-set centres.

These are metric equivalents to SAE J 490 Style 1 quick release detachable ball joints.

Tips

Standard thread is a right hand thread.

Order No.	Thread hand	d ₁	d ₂	l ₁	l ₂	d ₃	d ₄	d ₅	h ₁	h ₂	h ₃	l ₃	A/F	Weight g
65542.W0105	Right	6.35	M 5	23.0	28	7.9	11.1	4.35	11.1	11.9	28.6	11.1	8	17
65542.W0106	Right	7.9	M 6	24.6	30	9.4	13.0	4.95	12.6	12.6	33.4	13.0	10	25
65542.W0108	Right	8.6	M 8	31.7	40	11.1	16.0	5.8	15.2	15.2	40.6	14.3	11	48
65542.W0110	Right	10.7	M10	39.7	49	14.1	19.0	6.85	19.8	19.8	51.4	27.0	13	78

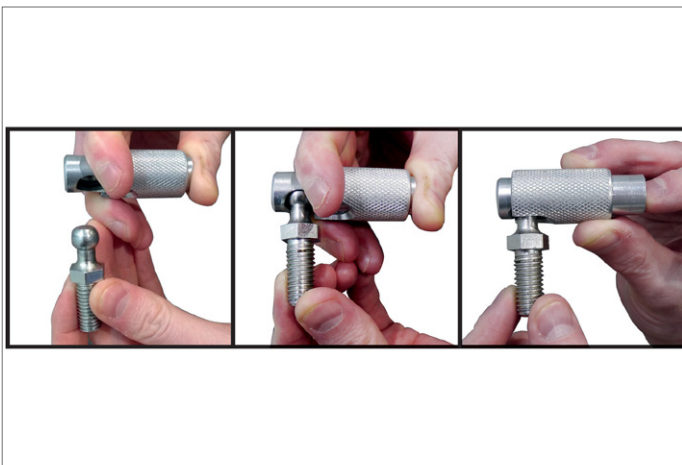



64500

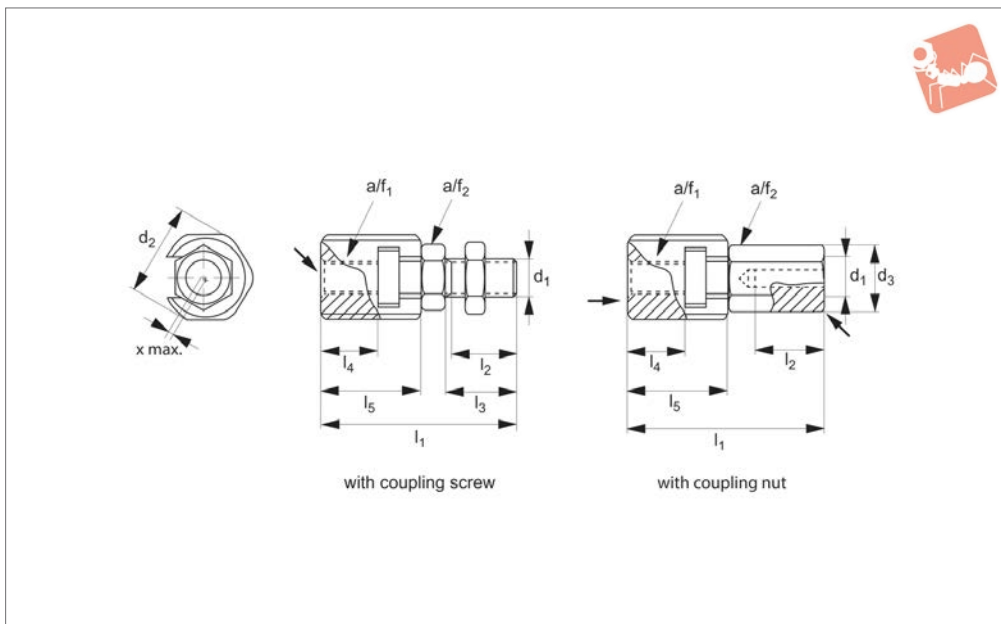

Material

Body: steel, heat-treated, phosphated.
Lock nut: steel, blackened (ISO 4035/8675).

Technical Notes

For quick coupling/uncoupling of components within a linear movement application, with the additional advantage

of compensating for radial off-set between the components. In built adjustment feature of the quick plug coupling means manual adjustment of the coupled units is unnecessary. Coupling via means of a t-slot channel within the coupling nut.

Tips

Can be linked to pneumatic and hydraulic

lifting cylinders in many different applications.

Important note: suitable for linear movement applications, does not transmit any torque.

Order No.	Coupling Type	d ₁	d ₂	d ₃	l ₁ ≈	l ₂ min.	l ₃	l ₄ min.	l ₅	Tensile & compression load kN max.	A/F ₁	A/F ₂	Axial offset x max.	Weight g
64500.W0006	Screw	M_6	21,0		37,5	11,0	14	9,0	18,0	2,5	19	10	0,6	44
64500.W0008	Screw	M_8	26,0		45,0	13,5	17	11,5	22,5	4,5	24	13	0,7	86
64500.W0010	Screw	M10	30,0		56,2	16,0	20	16,0	29,0	6,5	27	17	0,7	147
64500.W0012	Screw	M12	32,5		66,7	21,0	25	17,0	34,0	10,0	30	19	0,8	208
64500.W0016	Screw	M16	39,0		83,0	25,0	30	23,0	42,0	18,0	36	24	1,0	383
64500.W0020	Screw	M20	44,0		93,5	29,0	35	23,5	45,5	30,0	41	30	1,0	571
64500.W0030	Screw	M10 x 1,25	30,0		56,2	16,0	20	16,0	29,0	6,5	27	17	0,7	147
64500.W0032	Screw	M12 x 1,25	32,5		66,7	21,0	25	17,0	34,0	10,0	30	19	0,8	207
64500.W0036	Screw	M16 x 1,50	39,0		83,0	25,0	30	23,0	42,0	18,0	36	24	1,0	384
64500.W0040	Screw	M20 x 1,50	44,0		93,5	29,0	35	23,5	45,5	30,0	41	30	1,0	576
64500.W0056	Nut	M_6	21,0	11,0	37,5	11,0		9,0	18,0	2,5	19	10	0,6	47
64500.W0058	Nut	M_8	26,0	14,4	45,0	13,5		11,5	22,5	4,0	24	13	0,7	91
64500.W0060	Nut	M10	30,0	19,0	56,2	15,0		16,0	29,0	6,5	27	17	0,7	160
64500.W0062	Nut	M12	32,5	21,2	66,7	17,5		17,0	34,0	10,0	30	19	0,8	223
64500.W0066	Nut	M16	39,0	27,0	83,0	22,0		23,0	42,0	18,0	36	24	1,0	401
64500.W0070	Nut	M20	44,0	34,0	93,5	25,0		23,5	45,5	30,0	41	30	1,0	606
64500.W0080	Nut	M10 x 1,25	30,0	19,0	56,2	15,0		16,0	29,0	6,5	27	17	0,7	159
64500.W0082	Nut	M12 x 1,25	32,5	21,2	66,7	17,5		17,0	34,0	10,0	30	19	0,8	221
64500.W0086	Nut	M16 x 1,50	39,0	27,0	83,0	22,0		23,0	42,0	18,0	36	24	1,0	400
64500.W0090	Nut	M20 x 1,50	44,0	34,0	93,5	25,0		23,5	45,5	30,0	41	30	1,0	601



Quick Plug Couplings with radial offset compensation

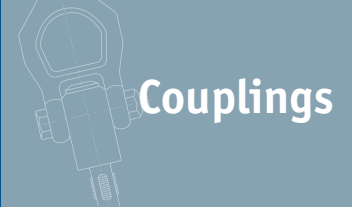

Couplings

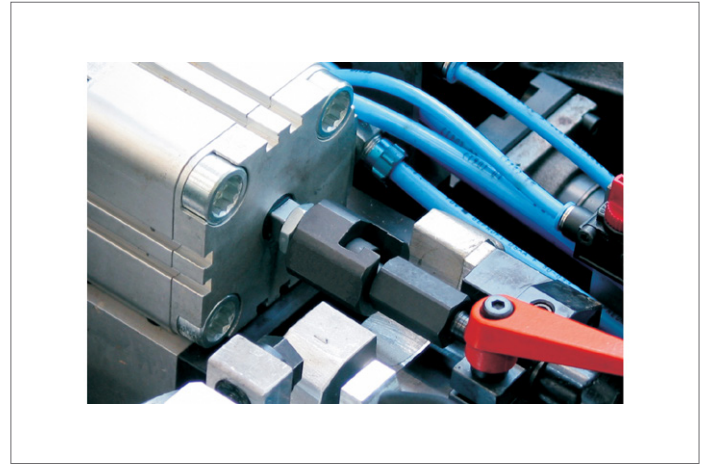
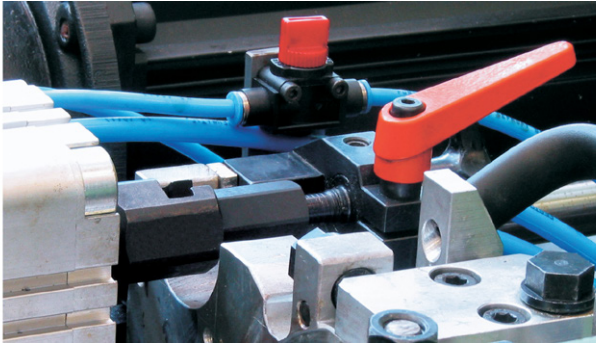

COUPLINGS



64600

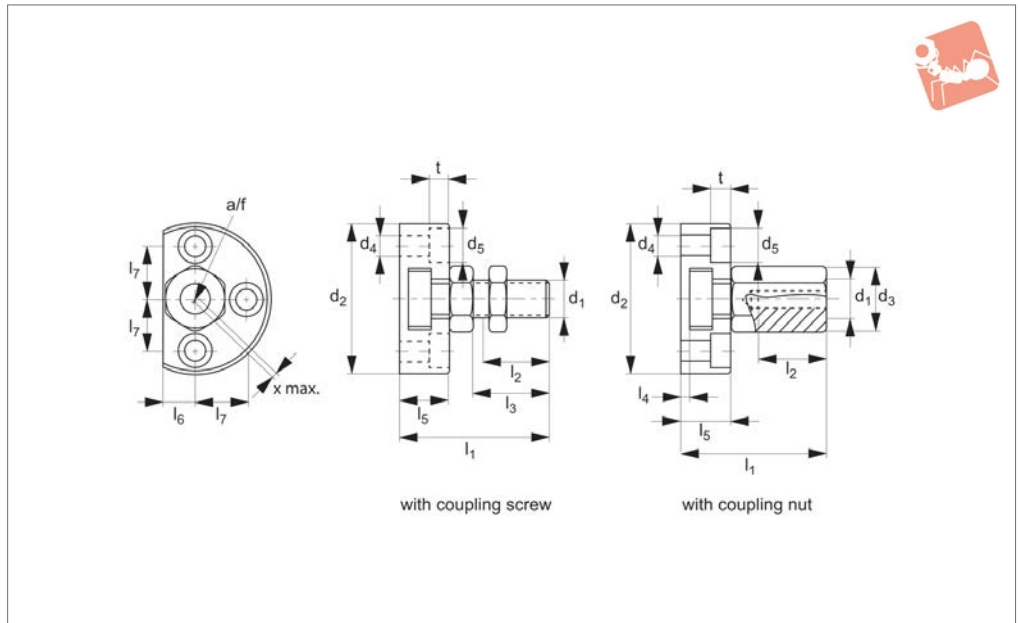

Material

Body: steel, heat-treated, tempered, phosphated.

Lock nut: steel, blackened (ISO 4035/8675).

Technical Notes

For quick coupling/uncoupling of components within a linear movement application, with the additional advantage

of compensating for radial off-set between the components. In built adjustment feature of the quick plug coupling means manual adjustment of the coupled units is unnecessary. Coupling via means of a t-slot channel within the coupling nut.

*kN max is the maximum tensile and compression load.

Tips

Ideal quick coupler where space is limited. Can be linked to pneumatic and hydraulic lifting cylinders in many different applications.

Important note: suitable for linear movement applications, does not transmit any torque.

Order No.	Coupling Type	d ₁	d ₂	d ₃	d ₄	d ₅	Weight g
64600.W0206	Screw	M_6	42	-	5.5	10	75
64600.W0208	Screw	M_8	48	-	6.6	11	116
64600.W0210	Screw	M10	50	-	6.6	11	175
64600.W0212	Screw	M12	55	-	6.6	11	281
64600.W0216	Screw	M16	65	-	9.0	15	458
64600.W0220	Screw	M20	80	-	11.0	18	817
64600.W0230	Screw	M10x1,25	50	-	6.6	11	176
64600.W0232	Screw	M12x1,25	55	-	6.6	11	280
64600.W0236	Screw	M16x1,50	65	-	9.0	15	454
64600.W0240	Screw	M20x1,50	80	-	11.0	18	850
64600.W0256	Nut	M_6	42	11.0	5.5	10	77
64600.W0258	Nut	M_8	48	14.4	6.6	11	123
64600.W0260	Nut	M10	50	19.0	6.6	11	187
64600.W0262	Nut	M12	55	21.2	6.6	11	295
64600.W0266	Nut	M16	65	27.0	9.0	15	472
64600.W0270	Nut	M20	80	34.0	11.0	18	849
64600.W0280	Nut	M10x1,25	50	19.0	6.6	11	187
64600.W0282	Nut	M12x1,25	55	21.2	6.6	11	298
64600.W0286	Nut	M16x1,50	65	27.0	9.0	15	477
64600.W0290	Nut	M20x1,50	80	34.0	11.0	18	852

Order No.	l ₁ ≈	l ₂ min.	l ₃	l ₄	l ₅	l ₆	l ₇	A/F	t	Axial offset x max.	kN kN max.
64600.W0206	30.5	11.0	14	3.0	11.0	7.0	14.0	10	5.4	0.6	2.5
64600.W0208	35.5	13.5	17	3.0	13.0	8.0	16.0	13	6.4	0.7	4.5
64600.W0210	43.2	16.0	20	4.2	16.0	9.0	17.0	17	6.4	0.7	6.5



Quick Plug Couplings

with radial offset compensation and screwed flange

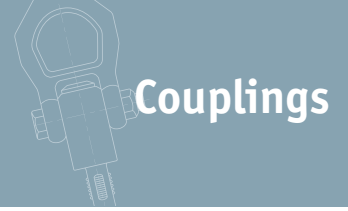

Order No.	l_1 ≈	l_2 min.	l_3	l_4	l_5	l_6	l_7	A/F	t	Axial offset x max.	kN kN max.
64600.W0212	53.2	21.0	25	4.2	20.5	10.0	19.0	19	6.4	0.8	10.0
64600.W0216	64.0	25.0	30	5.0	23.0	12.5	22.5	24	8.5	1.0	18.0
64600.W0220	74.0	29.0	35	5.0	26.0	17.0	28.0	30	10.4	1.0	30.0
64600.W0230	43.2	16.0	20	4.2	16.0	9.0	17.0	17	6.4	0.7	6.5
64600.W0232	53.2	21.0	25	4.2	20.5	10.0	19.0	19	6.4	0.8	10.0
64600.W0236	64.0	25.0	30	5.0	23.0	12.5	22.5	24	8.5	1.0	18.0
64600.W0240	74.0	29.0	35	5.0	26.0	17.0	28.0	30	10.0	1.0	30.0
64600.W0256	30.5	11.0	-	3.0	11.0	7.0	14.0	10	5.4	0.6	2.5
64600.W0258	35.5	13.5	-	3.0	13.0	8.0	16.0	13	6.4	0.7	4.5
64600.W0260	43.2	15.0	-	4.2	16.0	9.0	17.0	17	6.4	0.7	6.5
64600.W0262	53.2	17.5	-	4.2	20.5	10.0	19.0	19	6.4	0.8	10.0
64600.W0266	64.0	22.0	-	5.0	23.0	12.5	22.5	24	8.5	1.0	18.0
64600.W0270	74.0	25.0	-	5.0	26.0	17.0	28.0	30	10.0	1.0	30.0
64600.W0280	43.2	15.0	-	4.2	16.0	9.0	17.0	17	6.4	0.7	6.5
64600.W0282	53.2	17.5	-	4.2	20.5	10.0	19.0	19	6.4	0.8	10.0
64600.W0286	64.0	22.0	-	5.0	23.0	12.5	22.5	24	8.5	1.0	18.0
64600.W0290	74.0	25.0	-	5.0	26.0	17.0	28.0	30	10.0	1.0	30.0

COUPLINGS

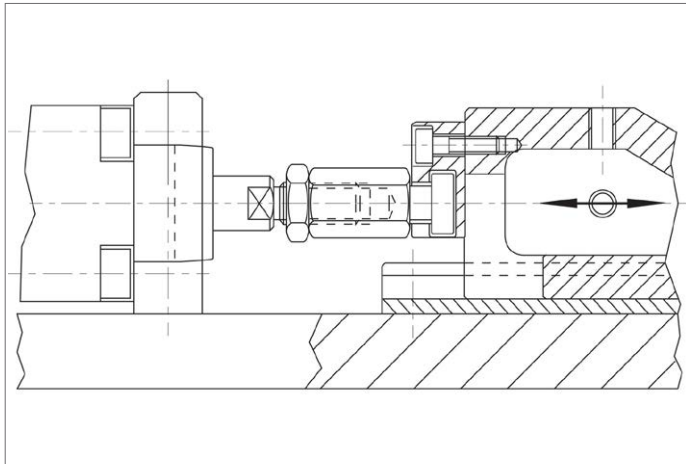



64700

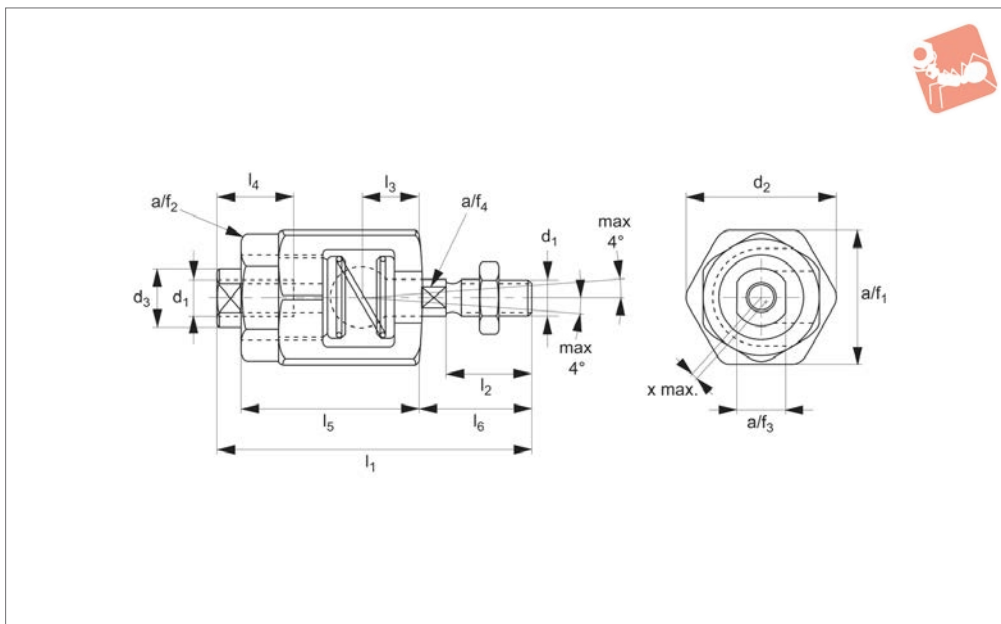

Material

Body: steel, heat-treated, tempered, phosphated.

Nut: steel, heat-treated, phosphated.

Spring: stainless steel.

Coupling part: steel, heat-treated, nitrided, blackened.

Lock nut: steel, blackened (ISO 4035/8675).

Technical Notes

Compensates for both radial off-set and

angular off-set between the components, making it ideal for applications with non-aligned linear components. Inbuilt adjustment feature of the quick plug coupling means manual adjustment of the coupled units is unnecessary. Coupling via means of a t-slot channel within the coupling nut.

Tips

Solid and compact design, no loose elements. Can be linked to pneumatic and hydraulic lifting cylinders in many different

applications.

Important note: suitable for linear movement applications, does not transmit any torque.

Order No.	d ₁	d ₂	d ₃	l ₁ ≈	l ₂	l ₃	Weight g
64700.W0406	M 6	24.5	9.6	52	14	9.5	75
64700.W0408	M 8	30.0	15.0	63	18	11.5	137
64700.W0410	M10	44.0	21.0	81	22	16.0	401
64700.W0412	M12	44.0	21.0	85	26	16.0	405
64700.W0416	M16	60.0	32.0	121	34	26.0	1127
64700.W0420	M20	60.0	32.0	129	42	26.0	1152
64700.W0430	M10x1,25	44.0	21.0	81	22	16.0	403
64700.W0432	M12x1,25	44.0	21.0	85	26	16.0	406
64700.W0436	M16x1,50	60.0	32.0	121	34	26.0	1128
64700.W0440	M20x1,50	60.0	32.0	129	42	26.0	1155

Order No.	l ₄ min.	l ₅	l ₆	Radial offset compensation max.	Tensile load kN max.	A/F ₁	A/F ₂	A/F ₃	A/F ₄
64700.W0406	13	29	18.5	0.6	2.5	22	19	8	5
64700.W0408	16	33	23.5	0.6	4.5	27	24	13	7
64700.W0410	24	43	30.5	0.7	6.5	41	36	18	12
64700.W0412	24	43	34.5	0.7	10.0	41	36	18	12
64700.W0416	34	62	45.0	1.0	18.0	55	46	27	18
64700.W0420	34	62	53.0	1.0	30.0	55	46	27	18
64700.W0430	24	43	30.5	0.7	6.5	41	36	18	12
64700.W0432	24	43	34.5	0.7	10.0	41	36	18	12
64700.W0436	34	62	45.0	1.0	18.0	55	46	27	18
64700.W0440	34	62	53.0	1.0	30.0	55	46	27	18



Quick Plug Couplings with angular radial offset compensation

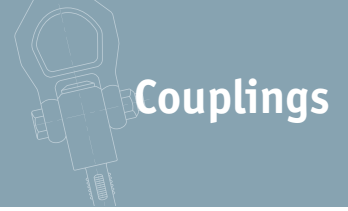

Couplings

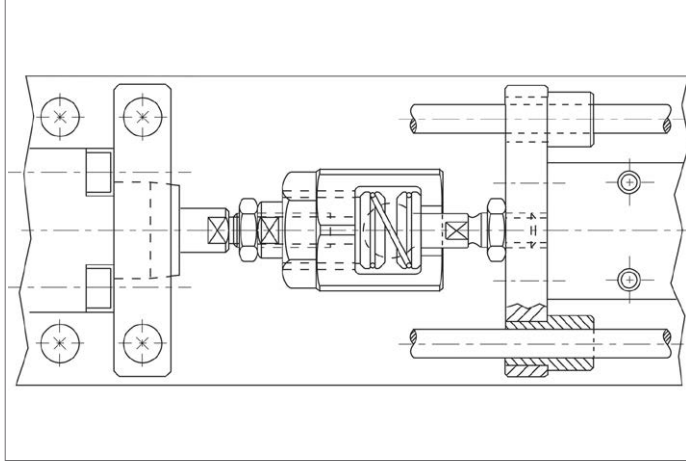

COUPLINGS



64775

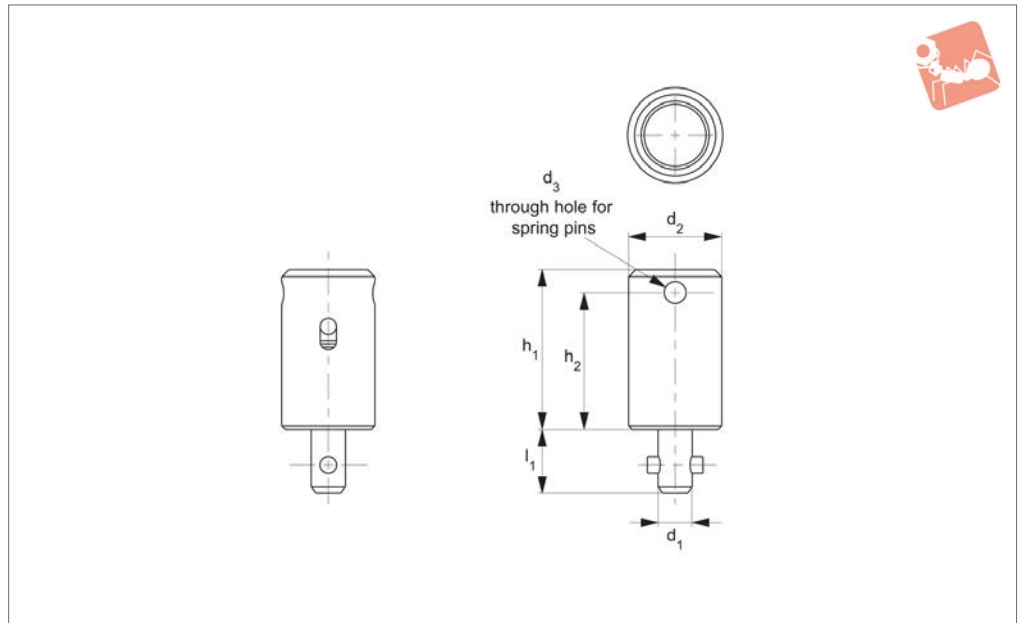

Material

Body: steel S45C, nickel plated.

Pin and Spring: stainless steel, SUS304

Technical Notes

For quick coupling/uncoupling of components within a linear movement application. Coupling via means of a 90° turn of coupling into the cam locking receiver. Please order receivers separately, see part nos. 64780 and 64782. Temperature resistant to 200 °C

Tips

Can be linked to pneumatic and hydraulic

lifting cylinders in many different applications.

Important Notes

Suitable only for linear movement applications, does not transmit any torque.

Actuation:

- Following installation dimensions for both coupling and receiver in introductory pages.

- Once coupling and receiver are correctly installed, align male coupling to female receiver, paying attention to correctly

align pins on the coupling's shaft to holes in receiver.

- Engage coupling and receiver, to lock turn shaft or block 90 degrees to clamp.

- When properly locked an audible „click“ is heard.

- When properly installed, repeatability of upto +/- 0.08mm is achievable.

- To release, reverse steps described above.

Order No.	d_1 -0.04 -0.08	d_2 -0.04 -0.08	d_3	h_1	h_2	l_1	Shear strength N	Tensile strength N	Clamping force N max.	Weight g
64775.W0514	5	14	3	23.5	20	9.5	1800	1200	30	25



Receiver - Shaft Mount - Cam Locking

for Quick Plug Coupling no. 64775

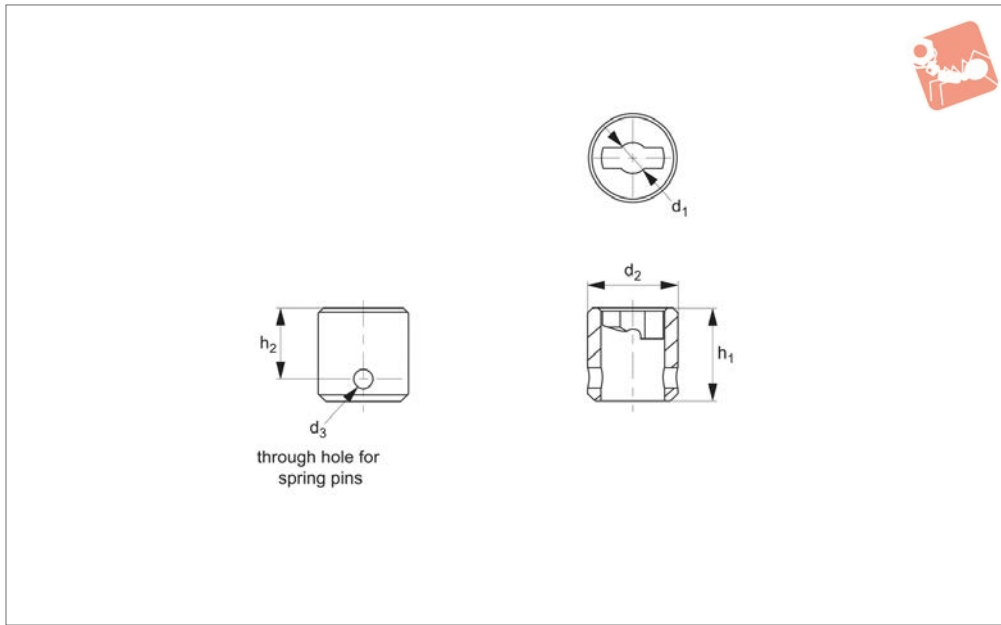
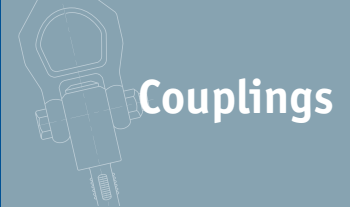

64780

COUPLINGS

Material

Body: tempered steel SCM440, nickel plated.

Technical Notes

Receiver for use with quick plug coupling,

cam locking no. 64775. Shaft mount version suited to installation on shafts; such as the end of pneumatic or hydraulic cylinders.
Temperature resistant to 200° C

Important Notes

Suitable only for linear movement applications, does not transmit any torque.

Order No.	d_1 +0.08 +0.04	d_2 tol. h9	d_3	h_1	h_2	Weight g
64780.W0514	5	14	3	14.5	11	10



Operating Principle

When the male quick plug coupling is fully inserted into the receiver and actuated, the internal spring is compressed to clamp the shaft.

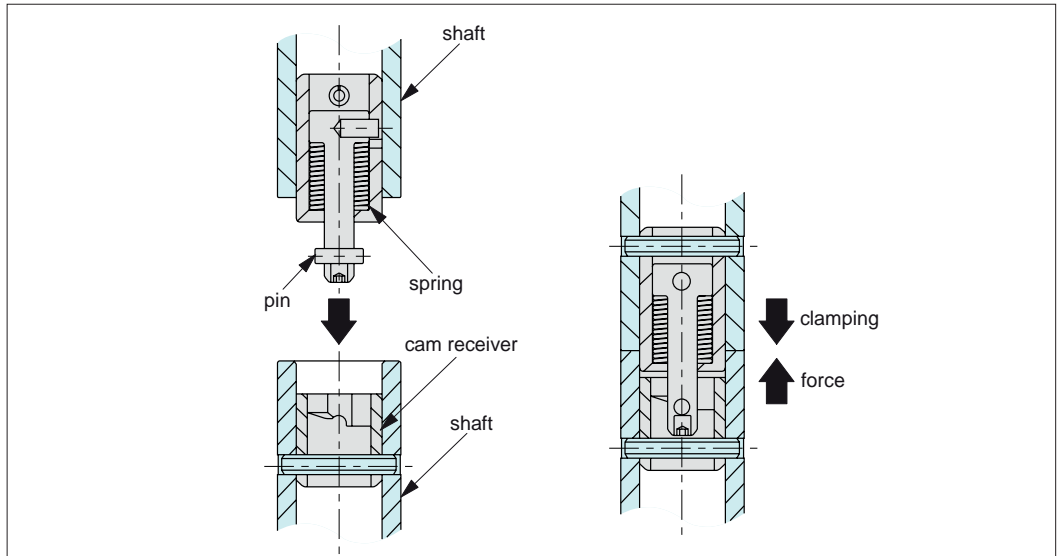

Operating Instructions

- 1 Insert the shaft into the keyway of cam receiver.
- 2 Rotate the shaft block 90° to clamp the element. An audible click can be heard when clamped. For unclamping, reverse these steps.

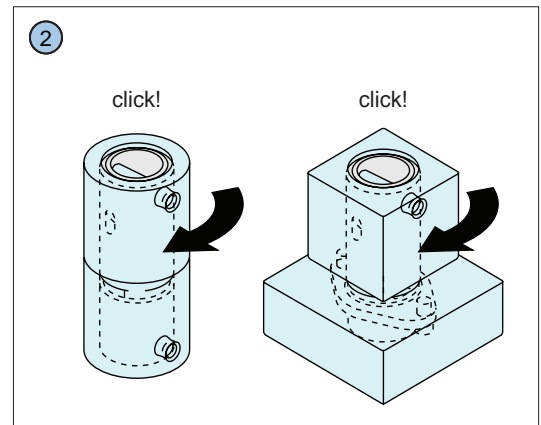
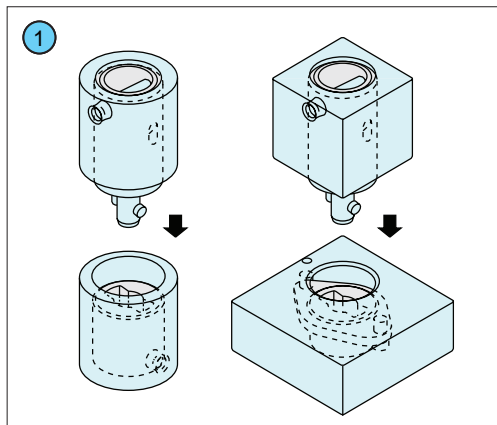

Operating Dimensions

How to mount shaft coupling clamp

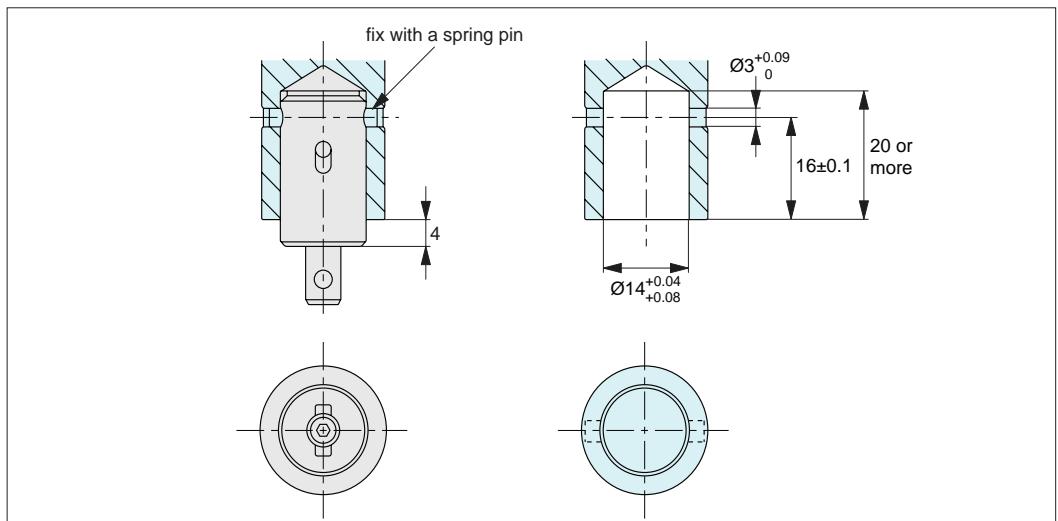

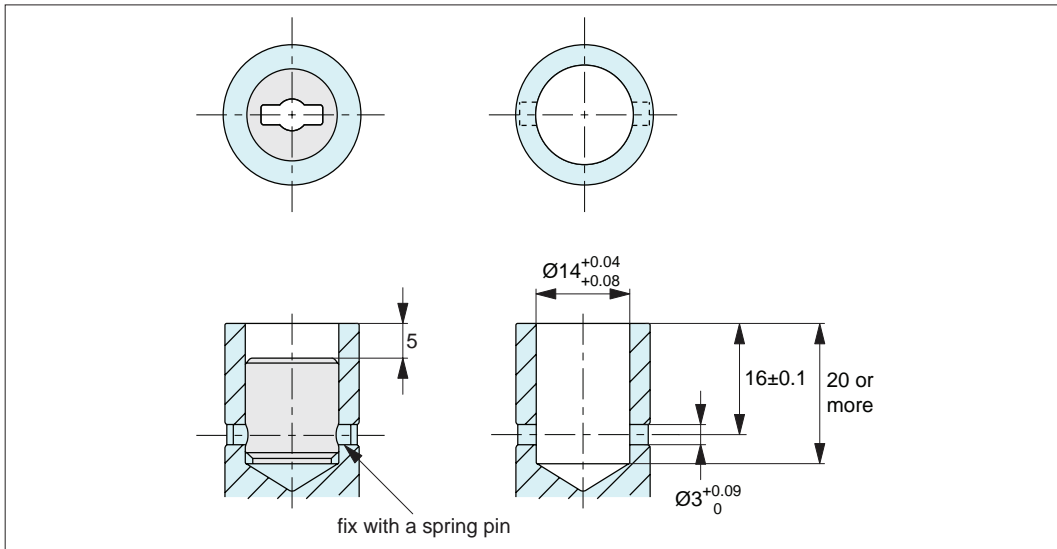

How to mount receiver (shaft mount)

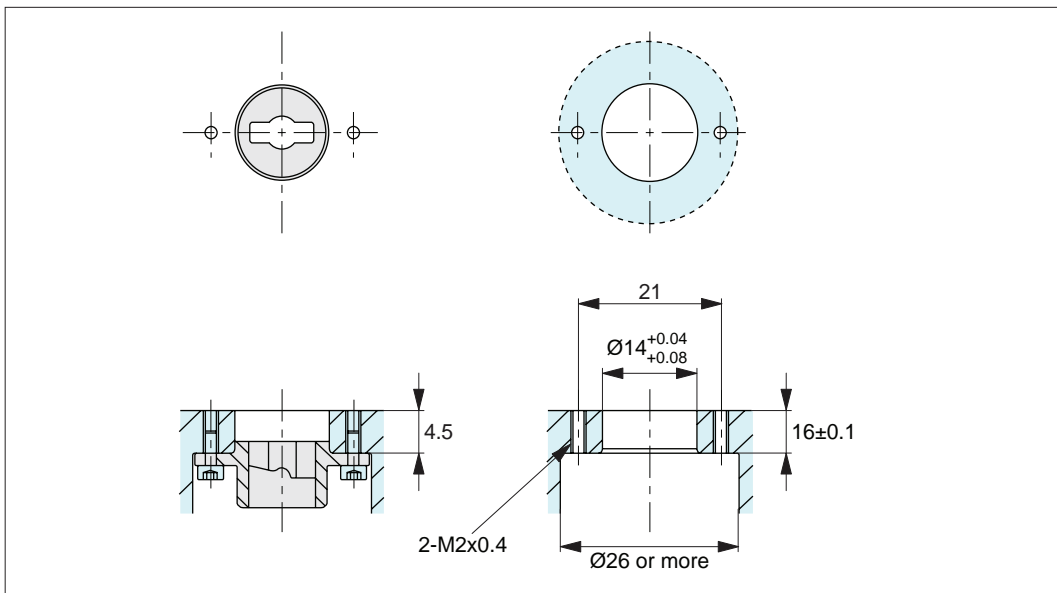

How to mount receiver (plate mount)

Repeatability

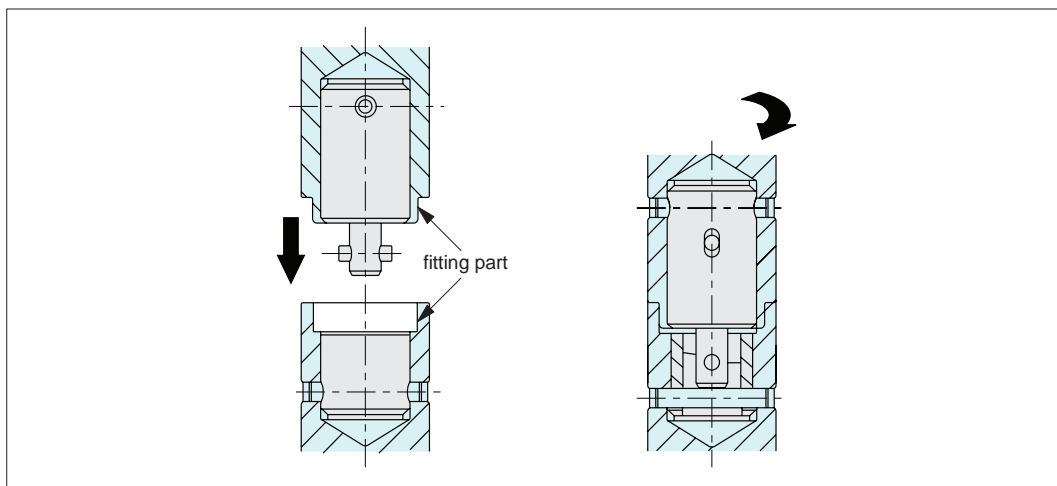

Prepare male and female fittings for highly accurate locating. Repeatability of ± 0.08 is achievable.

ov-W64775-A-T-W64780-A-T-b-rmh- Updated -31-10-2022



Applications

Changes of thrust pads

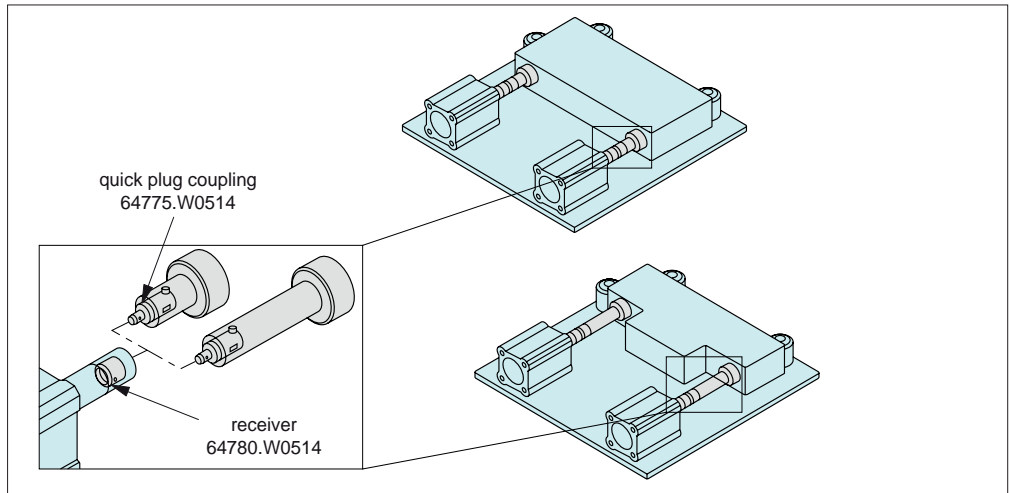

Changes of riser

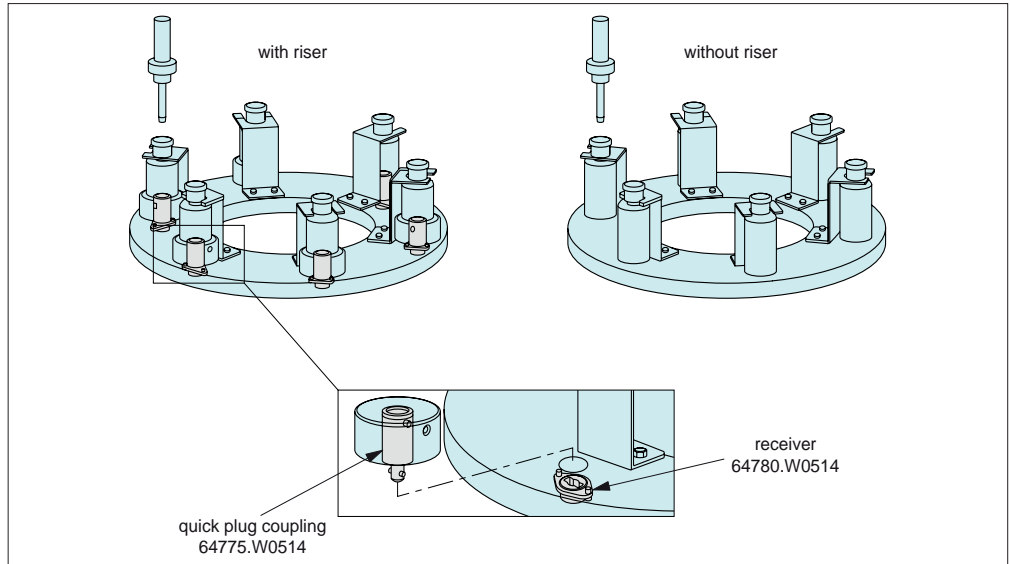

Notes

Pay attention to the direction of holes for spring pins.

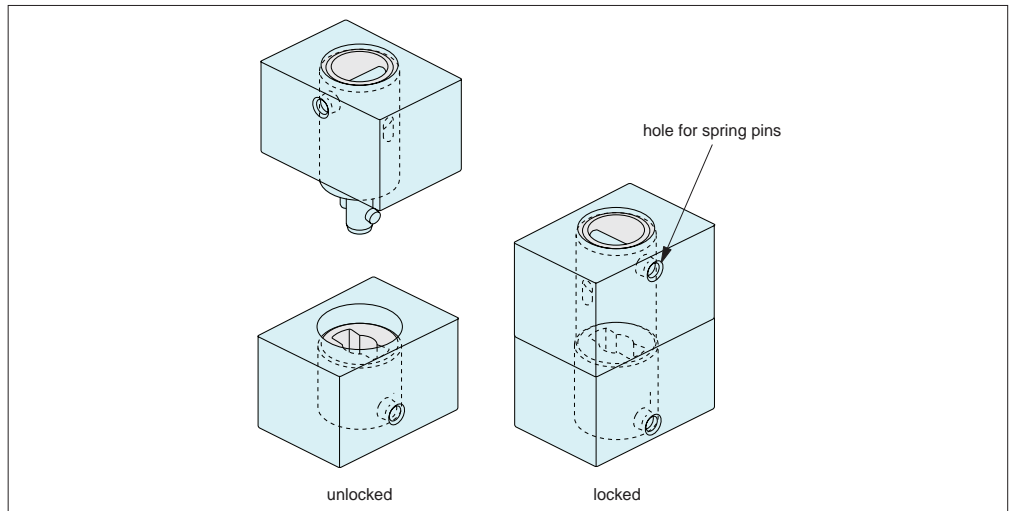



Receiver - Plate Mount - Cam Locking for Quick Plug Coupling no. 64775

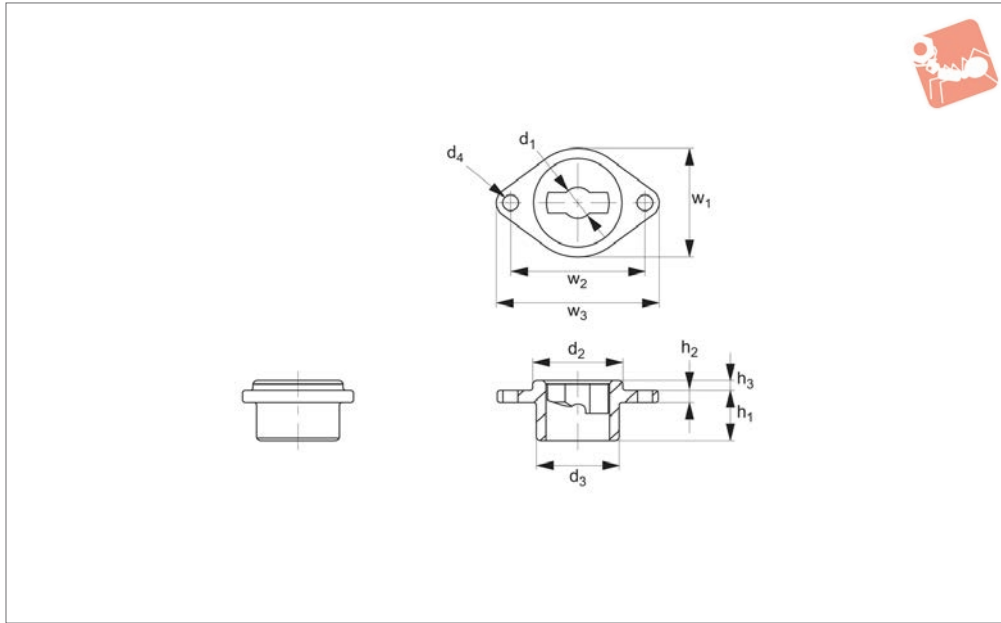
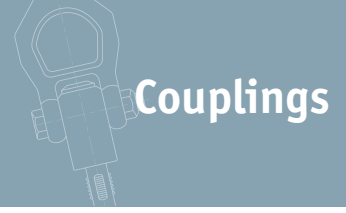

64782

COUPLINGS

Material

Body: tempered steel SCM440, nickel plated.

Technical Notes

Receiver for use with quick plug coupling,

cam locking no. 64775. Plate mount version suited to installation in thin walled parts, and sub-flush to the mounting surface.

Temperature resistant to 200° C

Suitable only for linear movement applications, does not transmit any torque.

Order No.	d_1 +0.08 +0.04	d_2 tol. h9	d_3	d_4	h_1	h_2	h_3	w_1	w_2	w_3	Weight g
64782.W0514	5	14	13	2.4	8	2	1.5	17	21	25	8

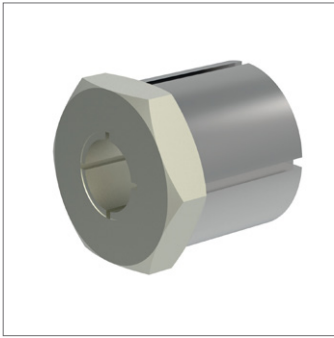

38400

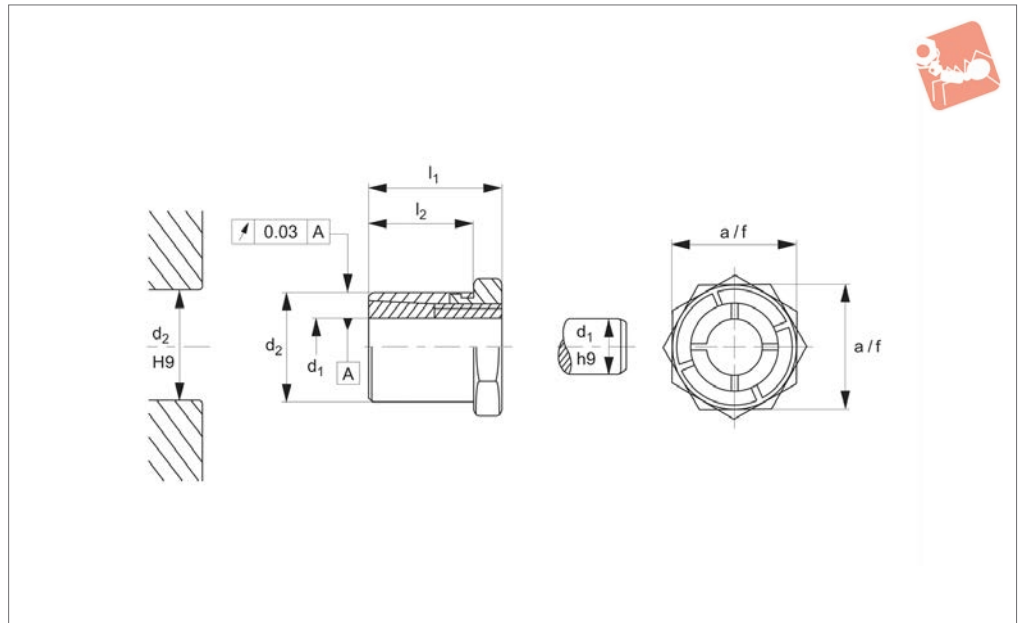

Material

Inner part: steel, blackened. Outer part: steel, galvanised. Nut: steel, nickel-plated.

Technical Notes

Ta = tightening torque of nut.
M = transferable torque.
Fa = transferable thrust load.

pw = surface pressure of shaft.

pn = surface pressure of hub.

The rotational accuracy is 0,03mm.

Please refer to technical pages for mounting instructions.

Tips

These self-centering and non-floating

tapered shaft hubs are used to easily and effectively achieve shaft/hub joints of machine elements such as sprocket wheels, gear wheels, belt pulleys, cams, levers etc. For special fork wrench see part 38420. W0814- .W0865.

Order No.	Finish	d ₁	d ₂	l ₁	l ₂	A/F	M Nm max.	pn N/mm ² max.	pw N/mm ² max.	Ta Nm max.	F _a kN max.	Weight g
38400.W0005	Without Lock Nut	5	14	19	15	14	10.1	96	264	9.9	4.0	20
38400.W0006	Without Lock Nut	6	14	19	15	14	12.1	96	220	9.9	4.0	19
38400.W0008	Without Lock Nut	8	16	22	17	16	23.4	91	179	16.9	5.8	26
38400.W0009	Without Lock Nut	9	20	24	19	22	43.7	115	245	34.9	9.7	47
38400.W0010	Without Lock Nut	10	20	24	19	22	48.6	115	221	34.9	9.7	46
38400.W0011	Without Lock Nut	11	22	24	19	22	59.9	117	225	43.8	10.9	51
38400.W0012	Without Lock Nut	12	22	24	19	22	65.3	117	206	43.8	10.9	49
38400.W0014	Without Lock Nut	14	26	28	22	27	93.0	99	178	65.0	13.3	83
38400.W0015	Without Lock Nut	15	26	28	22	27	99.0	99	166	65.0	13.3	78
38400.W0016	Without Lock Nut	16	26	28	22	27	106.0	99	156	65.0	13.3	73
38400.W0018	Without Lock Nut	18	35	36	27	36	223.0	125	224	161.0	24.8	201
38400.W0019	Without Lock Nut	19	35	36	27	36	235.0	125	212	161.0	24.8	189
38400.W0020	Without Lock Nut	20	35	36	27	36	248.0	125	201	161.0	24.8	186
38400.W0022	Without Lock Nut	22	42	41	30	46	349.0	110	197	250.0	31.8	346
38400.W0024	Without Lock Nut	24	42	41	30	46	381.0	110	180	250.0	31.8	326
38400.W0025	Without Lock Nut	25	42	41	30	46	397.0	110	173	250.0	31.8	315
38400.W0028	Without Lock Nut	28	47	44	33	50	565.0	110	174	355.0	40.4	403
38400.W0030	Without Lock Nut	30	47	44	33	50	605.0	110	162	355.0	40.4	378
38400.W0032	Without Lock Nut	32	55	51	38	55	764.0	102	166	490.0	47.8	632
38400.W0035	Without Lock Nut	35	55	51	38	55	836.0	102	151	490.0	47.8	571
38400.W0038	Without Lock Nut	38	62	58	43	65	1179.0	111	159	720.0	62.1	897
38400.W0040	Without Lock Nut	40	62	58	43	65	1241.0	111	151	720.0	62.1	842

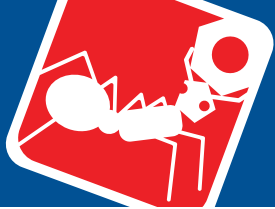

Tapered Shaft Hubs non-locking



Shaft Hubs

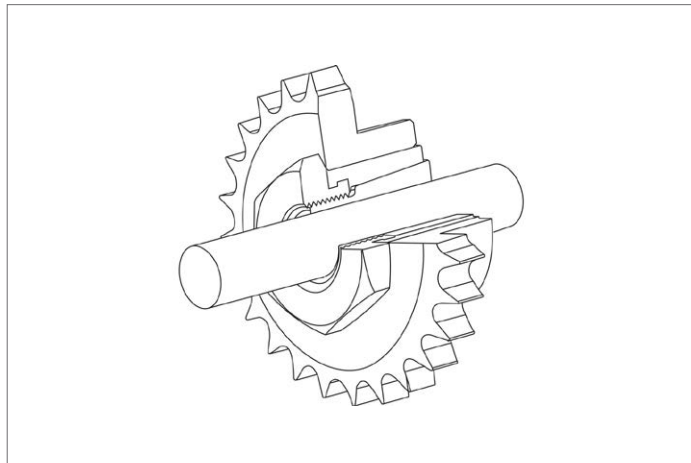

SHAFT HUBS

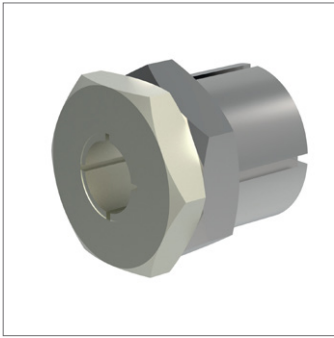

38420

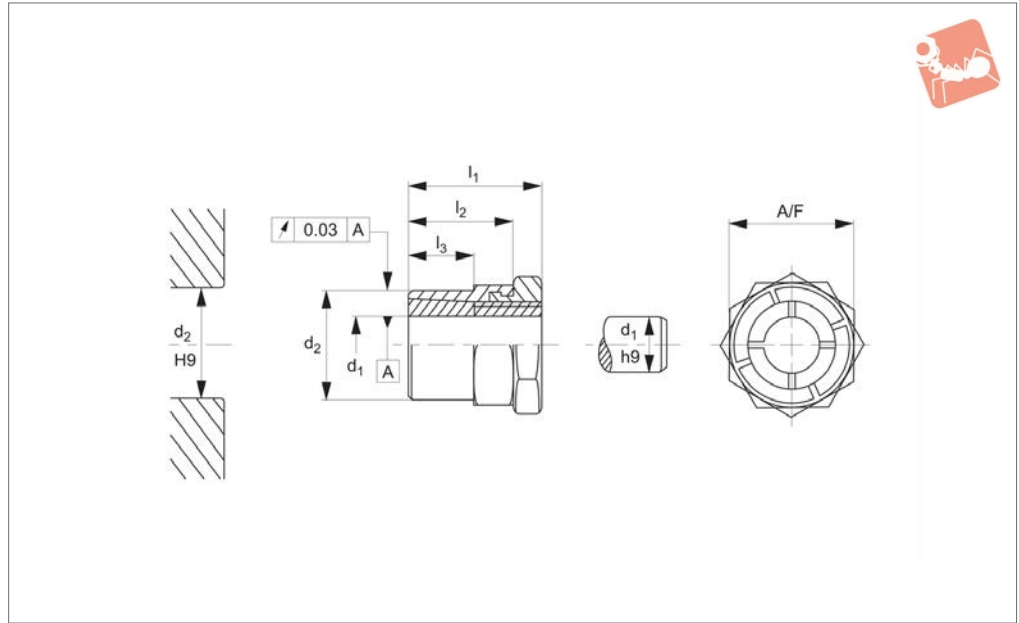

Material

Inner part: steel, nickel plated.
Outer part: steel, galvanised.
Nut: steel, nickel-plated.

Technical Notes

Ta = tightening torque of nut.
M = transferable torque.
Fa = transferable thrust load.

pw = surface pressure of shaft.
pn = surface pressure of hub.
Rotational accuracy is 0,3mm.
Please note special fork wrench is required for mounting, wrench thickness is equal to l2 - l3.

Tips

These self-centering and non-floating

tapered shaft hubs are used to easily and effectively achieve shaft/hub joints of machine elements such as sprocket wheels, gear wheels, belt pulleys, cams, levers etc. The lock nut enables locking of the shaft-hub joint, where free rotating shafts are used.

Order No.	Finish	d ₁	d ₂	l ₁	l ₂	l ₃	A/F	M Nm max.	pn N/mm ² max.	pw N/mm ² max.	Ta Nm max.	F _a kN max.	Weight g
38420.W0105	With Lock Nut	5	12	19	15	9	14	10.1	119	264	9.9	4.0	18
38420.W0106	With Lock Nut	6	12	19	15	9	14	12.1	119	220	9.9	4.0	17
38420.W0108	With Lock Nut	8	14	22	17	11	16	23.4	121	179	16.9	5.8	23
38420.W0109	With Lock Nut	9	18	24	19	12	22	43.7	127	245	34.9	9.7	47
38420.W0110	With Lock Nut	10	18	24	19	12	22	48.6	127	221	34.9	9.7	46
38420.W0111	With Lock Nut	11	20	24	19	12	22	59.9	128	225	43.8	10.9	47
38420.W0112	With Lock Nut	12	20	24	19	12	22	65.3	128	206	43.8	10.9	45
38420.W0114	With Lock Nut	14	24	28	22	15	27	93.0	107	178	65.0	13.3	78
38420.W0115	With Lock Nut	15	24	28	22	15	27	99.0	107	166	65.0	13.3	75
38420.W0116	With Lock Nut	16	24	28	22	15	27	106.0	107	156	65.0	13.3	70
38420.W0118	With Lock Nut	18	30	36	27	17	36	223.0	145	224	161.0	24.8	179
38420.W0119	With Lock Nut	19	30	36	27	17	36	235.0	145	212	161.0	24.8	169
38420.W0120	With Lock Nut	20	30	36	27	17	36	248.0	145	201	161.0	24.8	213
38420.W0122	With Lock Nut	22	38	41	30	20	46	349.0	122	197	250.0	31.8	341
38420.W0124	With Lock Nut	24	38	41	30	20	46	381.0	122	180	250.0	31.8	320
38420.W0125	With Lock Nut	25	38	41	30	20	46	397.0	122	173	250.0	31.8	310
38420.W0128	With Lock Nut	28	42	44	33	23	50	565.0	123	174	355.0	40.4	370
38420.W0130	With Lock Nut	30	42	44	33	23	50	605.0	123	162	355.0	40.4	348
38420.W0132	With Lock Nut	32	50	51	38	28	55	764.0	112	166	490.0	47.8	555
38420.W0135	With Lock Nut	35	50	51	38	28	55	836.0	112	151	490.0	47.8	501
38420.W0814	Special Fork Wrench	-	-	-	-	-	14	-	-	-	-	-	45
38420.W0816	Special Fork Wrench	-	-	-	-	-	16	-	-	-	-	-	72
38420.W0822	Special Fork Wrench	-	-	-	-	-	22	-	-	-	-	-	195
38420.W0827	Special Fork Wrench	-	-	-	-	-	27	-	-	-	-	-	195
38420.W0836	Special Fork Wrench	-	-	-	-	-	36	-	-	-	-	-	428
38420.W0846	Special Fork Wrench	-	-	-	-	-	46	-	-	-	-	-	610
38420.W0850	Special Fork Wrench	-	-	-	-	-	50	-	-	-	-	-	870
38420.W0855	Special Fork Wrench	-	-	-	-	-	55	-	-	-	-	-	1125



Tapered Shaft Hubs with lock nut



Shaft Hubs

Order No.	Finish	d_1	d_2	l_1	l_2	l_3	A/F	M Nm max.	pn N/mm ² max.	pw N/mm ² max.	Ta Nm max.	F _a kN max.	Weight g
38420.W0865	Special Fork Wrench	-	-	-	-	-	65	-	-	-	-	-	1295

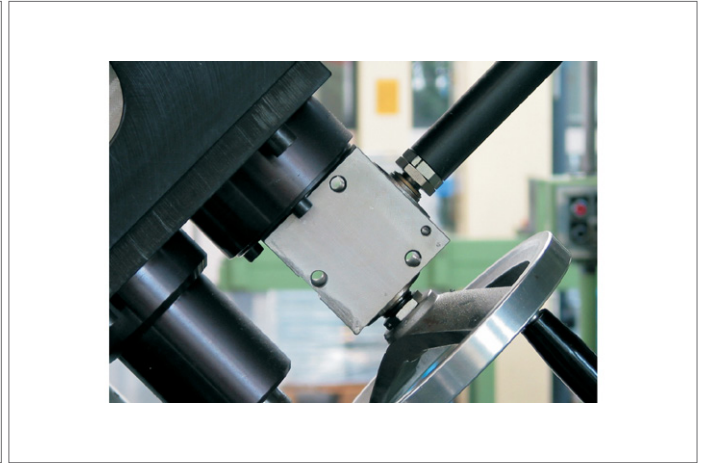
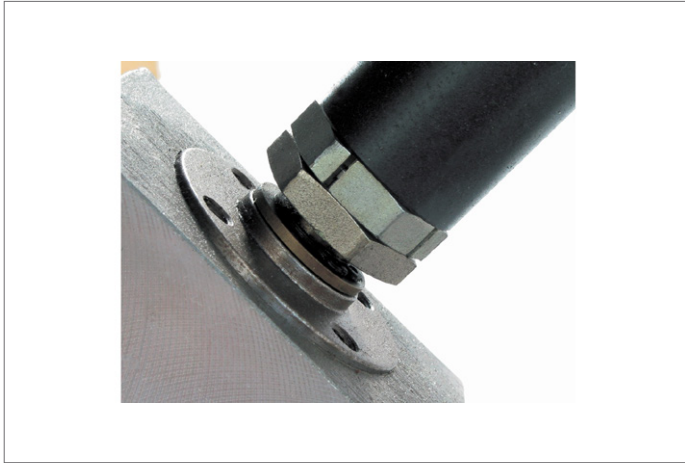

SHAFT HUBS

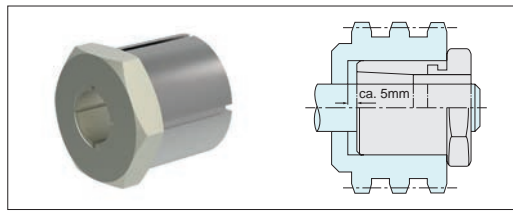

Tapered shaft hub with hexagon nut

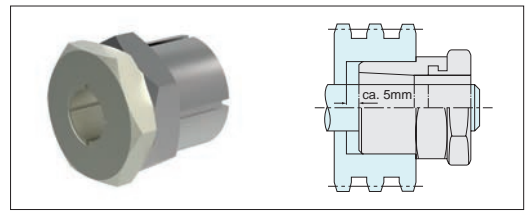

Tapered shaft hub with hexagon nut and lock nut

SHAFT HUBS

Applications

By using tapered shaft hubs, sprocket wheels, gear wheels, belt pulleys, cams, levers etc. can be easily and efficiently installed.

Tapered shaft hubs are available with or without lock nuts.

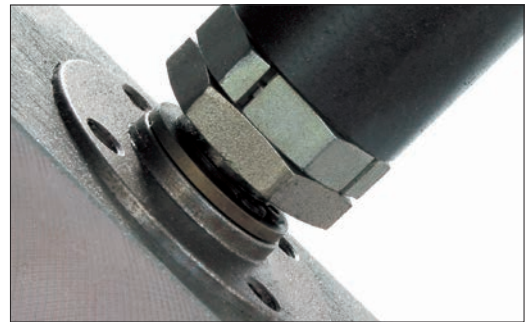
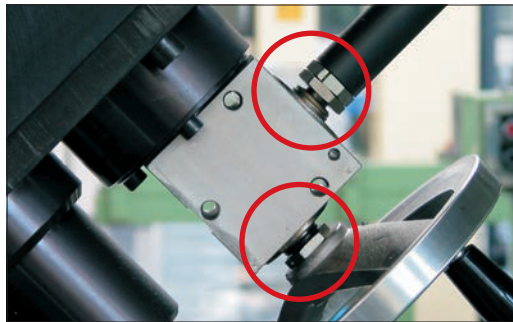

No Axial Shift

If, on mounting, the hub sits close to a collar, an axial offset is not possible. In this case, only 60% of the forces mentioned in the charts can be transmitted.

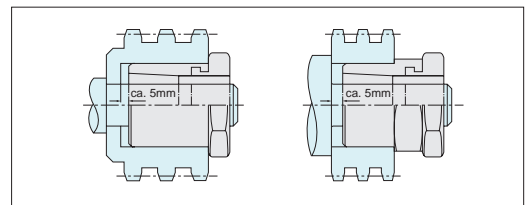

Two Tapered Shaft Hubs in One Hub

When using this method, the tapered shaft hub which is tightened first transmits 100% of the forces mentioned in the charts. When tightening the second tapered shaft hub, an axial offset of the hub is not possible. Therefore, this tapered shaft hub is able to transmit only 60% of the forces.

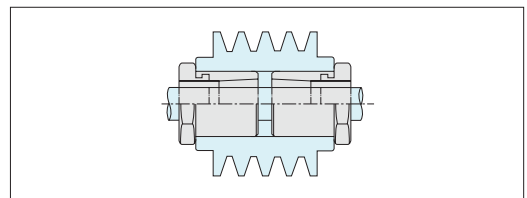

Assembly and Disassembly

Assembly

The contact surface of the shaft and the hub must be free from oil and dirt.

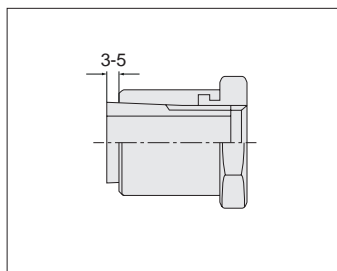

1. Rotate nut to the left until the inner part protrudes approx. 3-5mm over the outer.

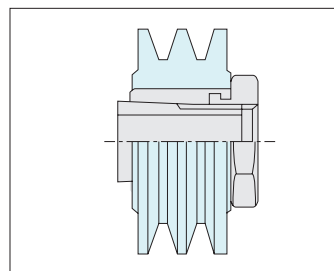

2. Install tapered shaft hub in the hub hole.

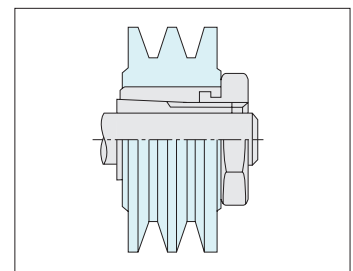

3. Slightly tighten the nut when located in the desired position. Compensate the axial offset thus produced with a soft-face mallet. Tighten the tapered shaft hub.

Disassembly

1. Release tapered shaft hub by turning the nut to the left until the inner part protrudes approx. 3-5mm over the outer part.

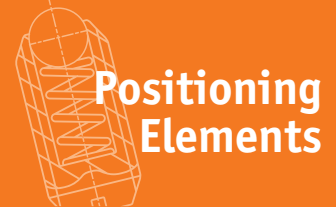

Simultaneous Exposure to Different Forces

If torque (M_t) and axial forces (F_a) are transmitted simultaneously, a resultant total torque (M_r) is obtained which must be less than or equal to the maximum torque (M_{max}) indicated in the charts. ($M_r \leq M_{max}$).

$$M_r = \sqrt{M_t^2 + \frac{F_a \times 2 \times 1000}{d_1} \times v}$$

M_r = Resultant total torque d_1 = Shaft diameter
 M_t = Torque v = Safety factor
 F_a = Axial force

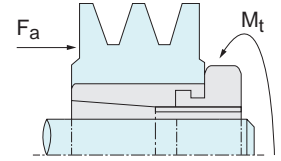

Example:

Shaft hub 38420.W0125

- M_t = 150Nm
- F_a = 5kN
- d_1 = 25mm
- v = 2

$$M_r = \sqrt{150^2 \text{Nm}^2 + \frac{5000 \text{N} \times 2 \times 1000 \text{mm/m}}{25 \text{mm}} \times 2} = 325 \text{Nm}$$

A maximum torque (M_{max}) of 520 Nm is transmitted by the tapered shaft hub 38420.W0125. The forces can be transmitted because M_r (325 Nm) is less than M_{max} .

Outside Diameter of Hub and Inside Diameter to Hollow Shaft

When fitting tapered shaft hubs, the outside diameter of the hub and the inside diameter of the hollow shaft have to be considered.

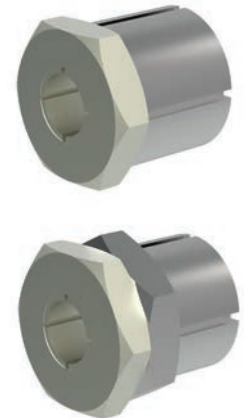
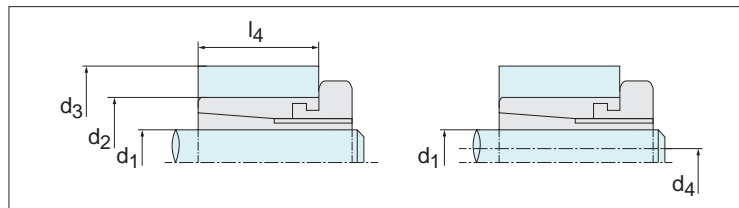

Smallest possible outside diameter of hub

$$d_3 \geq d_2 \times \sqrt{\frac{R_e + P_N \times C_N}{R_e - P_N \times C_N}} \quad [\text{mm}]$$

- d_1 = Shaft diameter
- d_2 = Hub hole
- d_3 = Outside diameter of hub
- d_4 = Inside diameter of hollow shaft
- R_e = Apparent yielding point
- $R_{p0,2}$ $R_{p0,1}$ = Permanent elongation limit

Largest possible inside diameter of hollow shaft

$$d_4 \leq d_1 \times \sqrt{\frac{R_e - 2P_W}{R_e (R_p)}} \quad [\text{mm}]$$

- P_N = Surface pressure hub
- P_W = Surface pressure shaft
- C_N = Factor [is "1", if the hub length is \geq the fitting length of the tapered shaft hub ($L_N \geq L_2$)]

Example:

Tapered shaft hub 38400.W0025, hub material GG25;

- $R_{p0,1}$ = 165Nmm²
- C_N = 1

Tapered shaft hub 38400.W0025, hub material CK45;

- R_e = 380Nmm²
- C_N = 1

$$d_3 \geq 42 \text{mm} \times \sqrt{\frac{165 \text{Nmm}^2 + 103 \text{Nmm}^2 \times 1}{165 \text{Nmm}^2 - 103 \text{Nmm}^2 \times 1}} \geq 87,4 \text{mm} \quad d_4 \leq 25 \text{mm} \times \sqrt{\frac{380 \text{Nmm}^2 - 2 \times 174 \text{Nmm}^2}{380 \text{Nmm}^2}} \leq 7,2 \text{mm}$$

Material Chart

Material										
	St 37-2	St 50-2	Ck 35	Ck 45	11 SMn 30	GG 15	GG 20	GG 25	GGG-40	AlMg 3 F 25
	Ust 37-2				11SMn Pb 30					
Minimum strength values in N/mm ²										
Diameter	Re	Re	Re	Re	Re	Rp 0,1	Rp 0,1	Rp 0,1	Rp 0,2	Re
16 < d_1 ≤ 40	225	285	320	380	375	90	130	165	250	180
40 < d_1 ≤ 100	205	265	260	300	245	90	130	165	250	180



61040

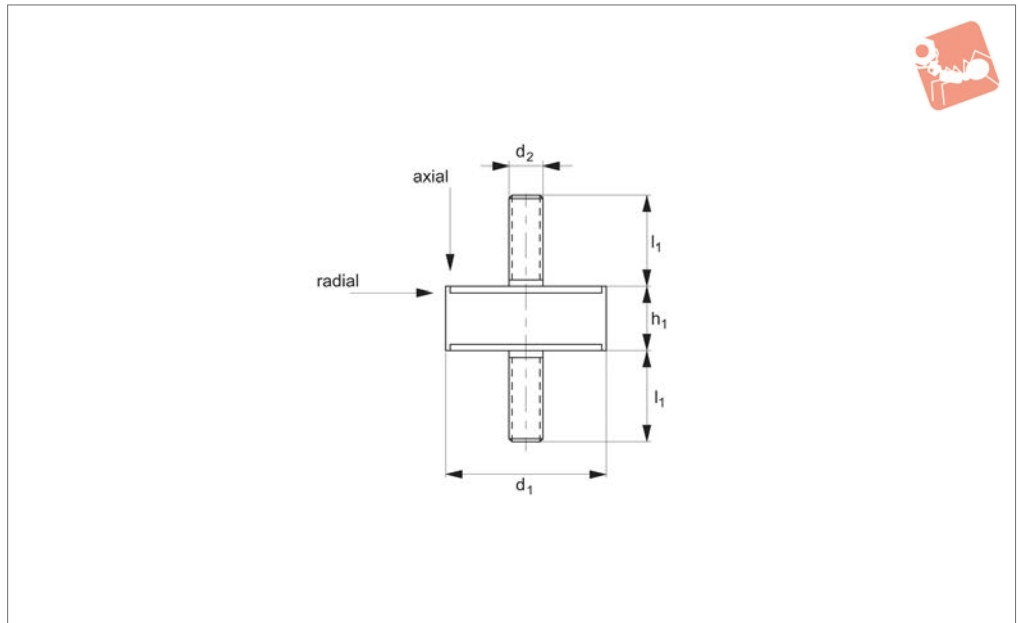

ANTI-VIBRATION

Material

Rubber on silver zinc plated steel (rubber hardness - 55 Shore A).

Technical Notes

Parts with small diameters (d_1) and relatively long length (h) cannot accept radial loads (as shown in table).

Different thread sizes on request.

For rubber mounted on stainless steel - see part no. 61042.

Tips

These cylinders are used to reduce vibration by allowing some movement (in axial

and radial as shown).

Typically used in machinery, compressors, air conditioning units, light engineering equipment etc.

Order No.	d_1	h_1	d_2	l_1	Axial load kgf max.	Radial load kgf max.
61040.W0061	6	7	M 3	10	3	-
61040.W0081	8	8	M 3	10	3	-
61040.W0091	9	12	M 4	10	6	1.5
61040.W0101	10	8	M 4	10	8	1.5
61040.W0102	10	10	M 4	10	10	1.5
61040.W0151	15	8	M 4	10-14	15	2.4
61040.W0152	15	10	M 4	10-14	13	2.4
61040.W0153	15	15	M 4	10-14	13	3.0
61040.W0154	15	20	M 4	10-14	10	-
61040.W0155	15	22	M 4	10-14	10	-
61040.W0156	15	25	M 4	10-14	9	-
61040.W0157	15	28	M 4	10-14	9	-
61040.W0161	16	15	M 4	14	13	2.4
61040.W0181	18	7.5	M 6	16	20	3.0
61040.W0182	18	8.5	M 6	16	20	3.0
61040.W0183	18	12	M 6	16	18	3.0
61040.W0202	20	9	M 6	13-16	27	5.0
61040.W0203	20	10	M 6	16	30	5.0
61040.W0204	20	15	M 6	16	25	5.0
61040.W0205	20	20	M 6	18	21	4.5
61040.W0206	20	25	M 6	16	20	4.0
61040.W0207	20	30	M 6	16	18	3.5
61040.W0251	20	35	M 6	13-16	18	3.5
61040.W0252	25	10	M 6	10-18	46	9.0
61040.W0253	25	15	M 6	18	44	8.5
61040.W0254	25	20	M 6	18	41	8.0
61040.W0255	25	25	M 6	18	40	7.5
61040.W0256	25	30	M 6	18	40	7.0
61040.W0258	25	40	M 6	18	36	4.0



Anti-vibration Cylinders

male:male



Anti-Vibration

Order No.	d ₁	h ₁	d ₂	l ₁	Axial load kgf max.	Radial load kgf max.
61040.W0303	30	15	M 8	20	90	12.0
61040.W0304	30	20	M 8	20	90	10.5
61040.W0305	30	25	M 8	20	85	10.5
61040.W0306	30	30	M 8	20	80	10.5
61040.W0351	35	40	M 8	23	54	13.0
61040.W0401	40	12	M 8	23	120	20.0
61040.W0402	40	20	M 8	20	160	20.0
61040.W0403	40	25	M 8	20	155	18.0
61040.W0404	40	28	M 8	20	155	16.0
61040.W0405	40	30	M 8	23	150	21.0
61040.W0406	40	40	M 8	23	120	22.0
61040.W0407	40	50	M 8	23	80	19.0
61040.W0451	45	30	M 8	23	112	24.0
61040.W0501	50	20	M10	25	250	30.0
61040.W0503	50	30	M10	25	250	29.0
61040.W0504	50	40	M10	25	220	29.0
61040.W0505	50	50	M10	25	200	29.0
61040.W0601	60	20	M10	28	285	35.0
61040.W0602	60	30	M10	28	200	37.0
61040.W0603	60	35	M10	30	350	39.0
61040.W0604	60	45	M10	30	300	42.0
61040.W0605	60	50	M10	37	185	42.0
61040.W0701	70	45	M10	35	270	55.0
61040.W0702	70	50	M10	30	350	52.0
61040.W0751	75	25	M12	35	650	75.0
61040.W0752	75	30	M12	37	350	75.0
61040.W0753	75	40	M12	35	500	75.0
61040.W0754	75	50	M12	37	330	65.0
61040.W0755	75	55	M12	35	450	60.0
61040.W0801	80	30	M14	35	900	75.0
61040.W0802	80	40	M14	35	600	50.0
61040.W0803	80	50	M14	35	750	65.0
61040.W0804	80	80	M14	51	280	60.0
61040.W0951	95	40	M16	45	1200	70
61040.W0952	95	55	M16	45	1000	70
61040.W0953	95	60	M16	45	800	70
61040.W0954	95	75	M16	45	800	70
61040.W1001	100	40	M16	45	1200	95
61040.W1002	100	60	M16	45	1100	90
61040.W1003	100	75	M16	45	1000	90
61040.W1201	120	50	M16	45	1500	100
61040.W1202	120	75	M16	45	1200	100
61040.W1203	120	100	M16	45	1000	100
61040.W1301	130	40	M16	45	1900	110
61040.W1302	130	50	M16	45	1600	110
61040.W1303	130	75	M16	45	1450	100
61040.W1304	130	100	M16	45	1200	120
61040.W1501	150	50	M20	50	1800	150
61040.W1502	150	60	M16	50	2200	150
61040.W1503	150	75	M16	50	2000	150
61040.W1504	150	100	M16	50	1400	150
61040.W1505	150	120	M16	50	1300	150
61040.W1506	150	140	M16	50	1200	150

ANTI-VIBRATION

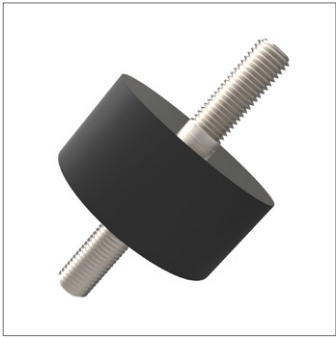

61042

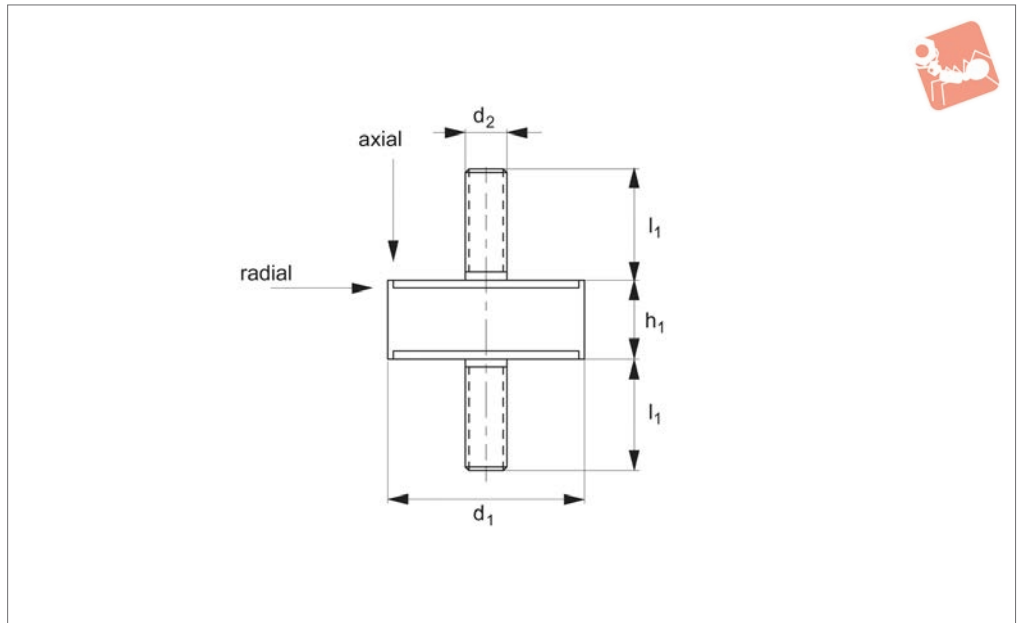

ANTI-VIBRATION

Material

Rubber on stainless steel, A2 (rubber hardness - 55 Shore A).

steel - see part no. 61040.

Tips

These cylinders are used to reduce vibration by allowing some movement (in axial and radial as shown).

Typically used in machinery, compressors, air conditioning units, light engineering equipment etc.

Technical Notes

For rubber mounted on silver zinc plated

Order No.	d ₁	h ₁	d ₂	l ₁	Compression max.	Axial load kgf max.	Radial load kgf max.
61042.W0200	20	20	M 6	18	4	25	4.5
61042.W0201	20	25	M 6	18	5	25	4.0
61042.W0250	25	25	M 8	18	5	40	7.5
61042.W0251	25	30	M 8	18	6	35	7.0
61042.W0300	30	30	M 8	18	6	80	10.5
61042.W0301	30	40	M 8	18	8	60	13.0
61042.W0302	35	35	M 8	18	8	90	13.0
61042.W0400	40	30	M10	27	8	150	21.0
61042.W0401	40	40	M10	27	10	120	22.0
61042.W0500	50	30	M10	27	8	250	29.0
61042.W0501	50	40	M10	27	10	220	29.0
61042.W0502	50	50	M10	27	12	200	29.0
61042.W0600	60	45	M10	27	10	300	42.0
61042.W0601	60	60	M10	27	12	250	44.0



Anti-vibration Cylinders Waisted male

Anti-Vibration

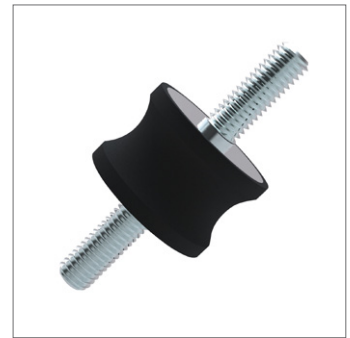
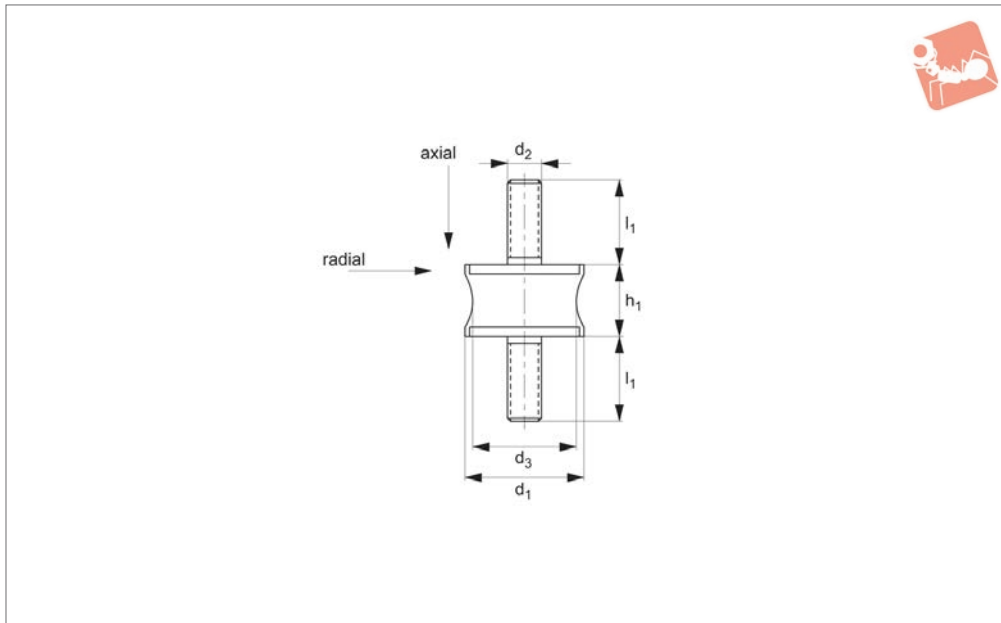

61100

ANTI-VIBRATION

Material

Rubber on silver zinc plated steel (rubber hardness - 55 Shore A).

Available in stainless steel on request.

Technical Notes

For rubber mounted on silver zinc plated

steel see part no. 61102 (female:female) or 61110 (male:female).

Tips

These cylinders are used to reduce vibration by allowing some movement (in axial and radial as shown in drawing).

Typically used in machinery, compressors, air conditioning units, light engineering equipment etc.

Order No.	d ₁	h ₁	d ₂	d ₃	l ₁	Axial load kgf max.	Radial load N max.
61100.W0012	12	14	M 4	7	10	2.5	1.0
61100.W0020	20	15	M 6	14	13-16	10	2.5
61100.W0021	20	20	M 6	12	18	15	2.5
61100.W0025	25	20	M 6	18	18	25	6.0
61100.W0030	30	20	M 8	25	23	35	6.0
61100.W0031	30	25	M 8	24	20	40	6.0
61100.W0040	40	28	M10	22	25	60	12
61100.W0045	45	50	M 8	25	23	60	-
61100.W0050	50	30	M10	42	28	120	25
61100.W0057	57	44	M 8	25	20	40	-
61100.W0060	60	36	M10	37	30	90	-
61100.W0061	60	43	M10	35	30	70	12
61100.W0062	60	60	M10	51	30	150	30
61100.W0070	70	56	M12	50	35	220	-
61100.W0080	80	70	M14	70	50	170	55
61100.W0090	90	77	M16	79	45	500	-
61100.W0095	95	76	M16	80	46	250	-
61100.W0108	108	85	M16	95	45	800	-
61100.W0130	130	96	M16	115	45	1400	-



61115

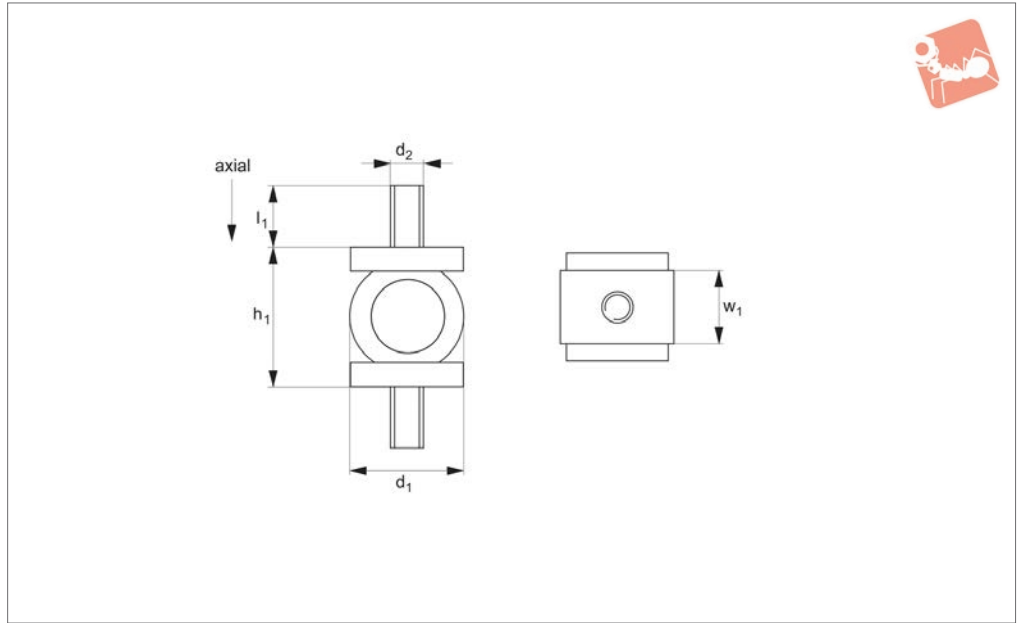

ANTI-VIBRATION

Material

Rubber on silver zinc-plated steel (rubber hardness - 55 Shore A).

frequencies with low loads as little as 0.5 kg.

Technical Notes

The spherical mounts are designed for low

Tips

These mounts are not to be used for radial loads.

Order No.	d ₁	h ₁	d ₂	w ₁	l ₁	Compression max.	Axial load kgf max.
61115.W0150	15	18	M4	14	8	5	1.25
61115.W0151	15	18	M4	14	8	5	2.50
61115.W0300	30	30	M8	30	20	11	3.50



Acceptable loads

Cylindrical mounts are never to be used in tension, they should only be used in axial or radial. Radial loads are however considerably less than axial loads. Parts with small diameters (d_1) and relatively long lengths (h) cannot accept radial loads.

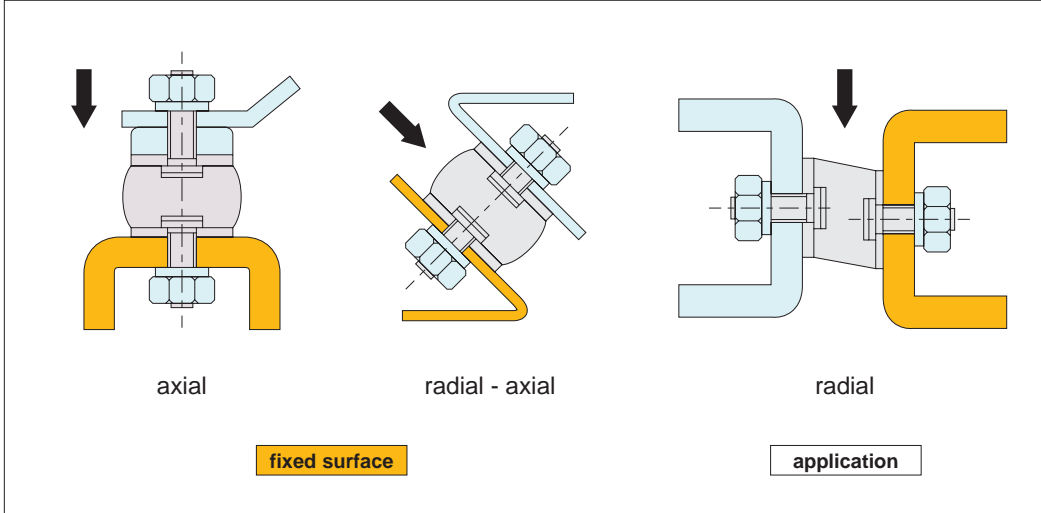

Installation

Incorrect installation

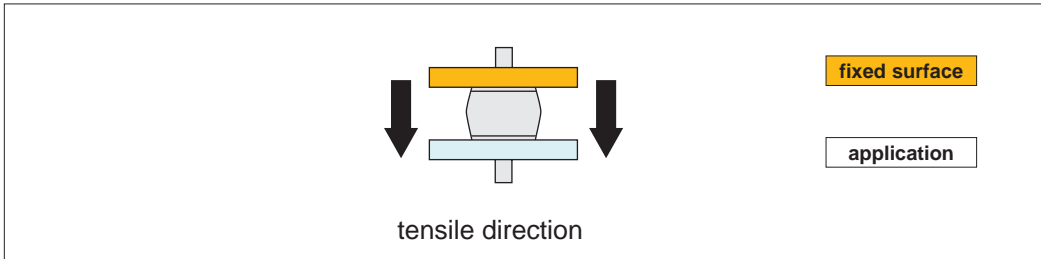

Correct installation

The height of the insulator may vary as the rubber is compressed under load.

Do not remove the rubber burr around the edge of the metal, this could cause detachment of rubber from the metal studs.

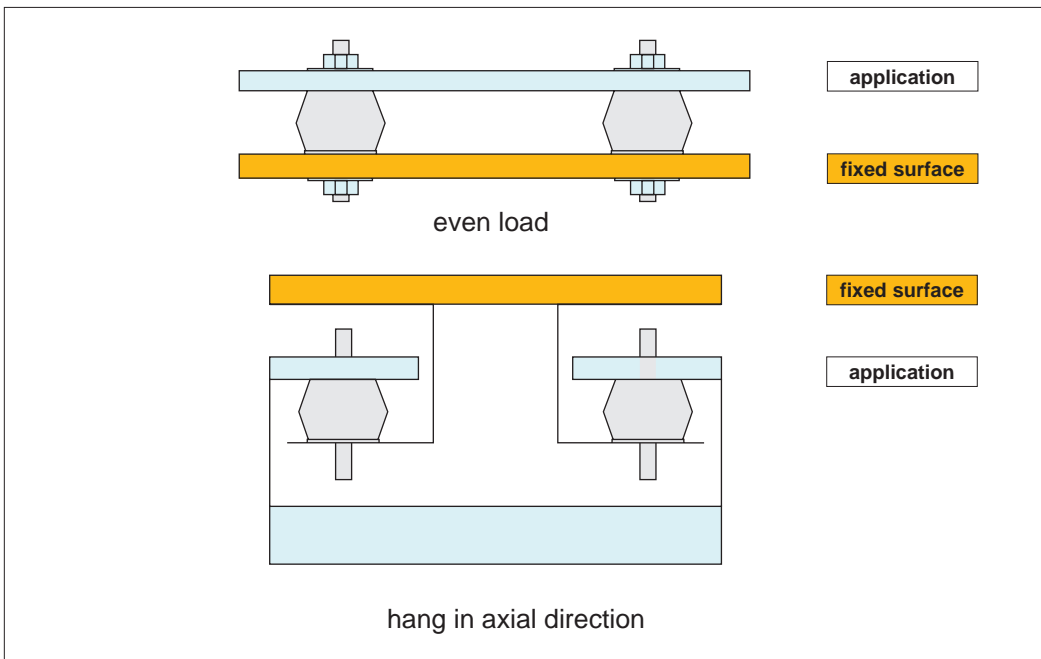

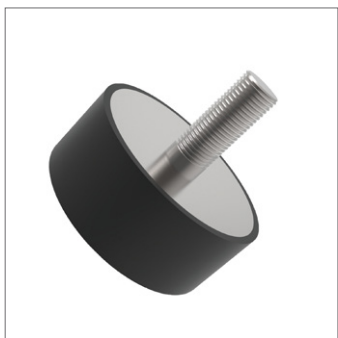

61060

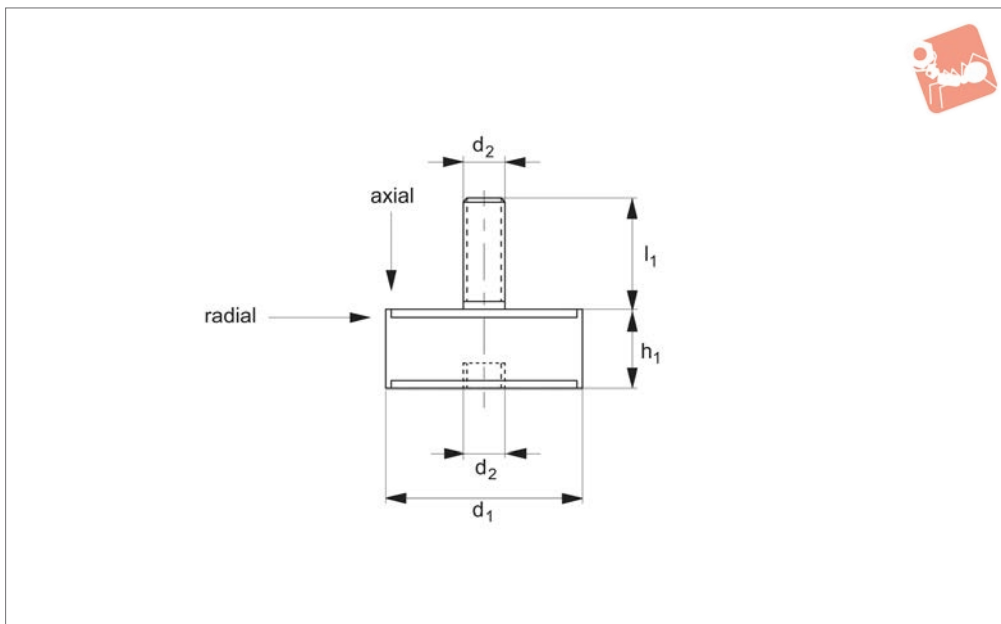

Material

Rubber on silver zinc plated steel (rubber hardness - 55 Shore A).

(d_1) and relatively long length (h) cannot accept radial loads (as shown in table).

tion by allowing some movement (in axial and radial as shown).

Technical Notes

Load tolerance parts with small diameters

Tips

These cylinders are used to reduce vibra-

Typically used in machinery, compressors, air conditioning units, light engineering equipment etc.

Order No.	d_1	h_1	d_2	l_1	Compression max.	Axial load kgf max.	Radial load kgf max.
61060.W0153	15	22	M 4	14	4.5	10	2.5
61060.W0081	8	8	M 3	10	1.5	3.5	-
61060.W0101	10	10	M 4	10	2.0	10	1.2
61060.W0121	12	31	M 5	20	3.5	6	1.3
61060.W0152	15	20	M 4	10	4.0	10	2.0
61060.W0154	15	25	M 4	10	5.0	9.5	2.0
61060.W0201	20	15	M 6	13	3.0	25	5.0
61060.W0202	20	20	M 6	18	4.0	25	4.0
61060.W0203	20	25	M 6	18	5.0	25	4.0
61060.W0204	20	30	M 6	18	7.0	25	3.0
61060.W0205	20	35	M 6	16	8.0	18	2.0
61060.W0251	25	15	M 6	16	3.0	50	8.0
61060.W0252	25	20	M 6	16	4.0	50	8.0
61060.W0253	25	25	M 6	18	5.0	40	7.0
61060.W0254	25	30	M 6	16	6.0	40	7.0
61060.W0255	25	35	M 6	18	8.0	36	6.0
61060.W0301	30	15	M 8	20	3.0	90	12.0
61060.W0302	30	20	M 8	20	4.0	90	11.0
61060.W0303	30	25	M 8	20	5.0	85	10.0
61060.W0304	30	30	M 8	20	6.0	80	10.0
61060.W0351	35	40	M 8	20	8.5	60	13.0
61060.W0401	40	30	M 8	20	8.0	150	21.0
61060.W0402	40	40	M 8	20	10.0	120	22.0
61060.W0403	40	50	M 8	23	13.0	80	18.0
61060.W0451	45	30	M 8	23	9.0	112	24.0
61060.W0500	50	30	M10	25	8.0	250	29.0
61060.W0501	50	40	M10	25	10.0	220	29.0
61060.W0502	50	45	M10	25	11.0	210	28.0
61060.W0503	50	50	M10	25	12.0	200	28.0
61060.W0504	50	60	M10	28	13.5	110	28.0
61060.W0601	60	30	M10	28	6.0	200	37.0

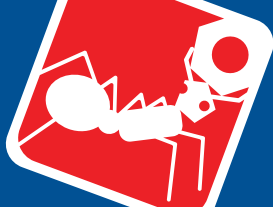

Anti-vibration Cylinders

male:female



Order No.	d ₁	h ₁	d ₂	l ₁	Compression max.	Axial load kgf max.	Radial load kgf max.
61060.W0602	60	35	M10	30	7.0	350	39.0
61060.W0603	60	45	M10	30	10.0	300	42.0
61060.W0604	60	50	M10	37	11.0	185	42.0
61060.W0701	70	45	M10	35	8.5	270	55.0
61060.W0702	70	50	M10	30	10.0	350	52.0
61060.W0703	70	55	M10	35	10.5	240	49.0
61060.W0751	75	25	M12	35	5.0	350	75.0
61060.W0752	75	30	M12	37	7.0	345	72.0
61060.W0753	75	40	M12	35	9.0	500	65.0
61060.W0755	75	55	M12	35	13.0	450	65.0
61060.W0801	80	30	M14	35	5.5	900	75.0
61060.W0802	80	40	M14	35	9.0	600	72.0
61060.W0803	80	50	M14	35	10.0	750	65.0
61060.W0804	80	70	M14	35	15.0	550	65.0
61060.W0951	95	40	M14	45	8.0	1200	70.0
61060.W0952	95	55	M14	45	11.0	1000	70.0
61060.W0953	95	60	M16	45	12.0	800	70.0
61060.W0954	95	75	M16	45	13.0	700	70.0
61060.W1001	100	40	M16	45	8.0	1200	95.0
61060.W1002	100	60	M16	45	15.0	1100	90.0
61060.W1003	100	75	M16	45	17.0	1000	80.0
61060.W1201	120	50	M16	45	9.0	1500	100.0
61060.W1202	120	75	M16	45	13.0	1500	100.0
61060.W1203	120	100	M16	45	16.0	1000	100.0
61060.W1301	130	40	M16	45	16.0	1900	120.0
61060.W1302	130	50	M16	45	9.0	1600	120.0
61060.W1303	130	75	M16	45	13.0	1450	120.0
61060.W1304	130	100	M16	45	16.0	1200	120.0
61060.W1501	150	50	M20	20	9.0	1800	150.0
61060.W1502	150	60	M20	20	14.0	1800	150.0
61060.W1503	150	75	M20	20	16.0	2000	150.0
61060.W1504	150	100	M20	20	16.0	1400	150.0
61060.W1505	150	120	M20	20	16.0	1300	150.0
61060.W1506	150	140	M20	20	16.0	1200	150.0

ANTI-VIBRATION



61110

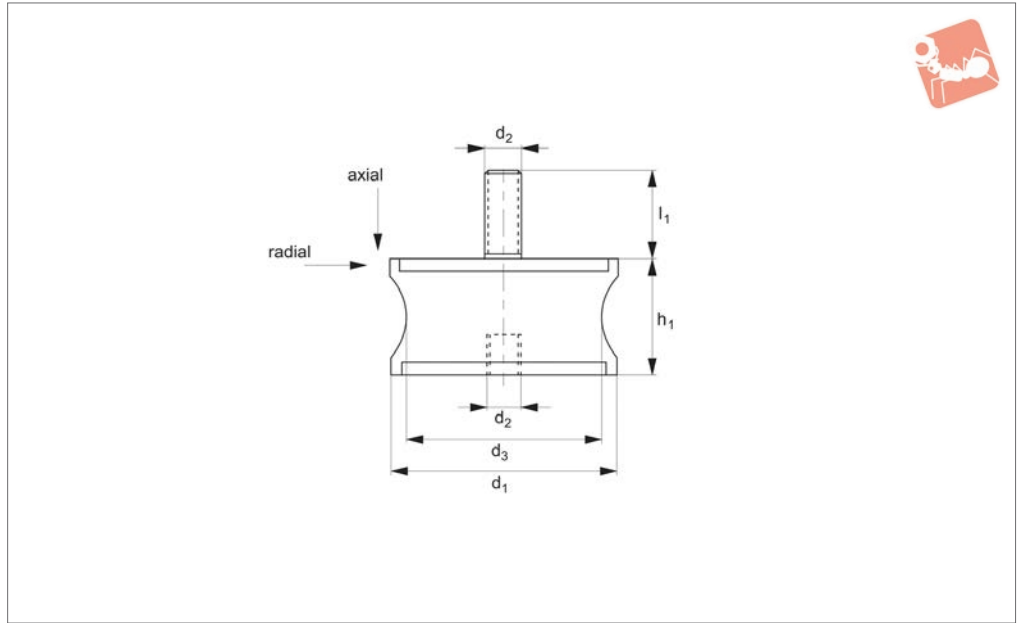

ANTI-VIBRATION

Material

Rubber on silver zinc plated steel (rubber hardness - 55 Shore A).

Tips

These cylinders are used to reduce vibra-

tion by allowing some movement (in axial and radial as shown).

Typically used in machinery, compressors, air conditioning units, light engineering equipment etc.

Order No.	d ₁	h ₁	d ₂	l ₁	d ₃	Compression max.	Axial load kgf max.	Radial load kgf max.
61110.W0200	20	20	M 6	18	12	2.5	15	3.0
61110.W0250	30	25	M 8	20	24	4	40	4.0
61110.W0400	40	28	M10	25	22	5	60	2.5
61110.W0600	60	36	M10	30	37	5	90	7.0
61110.W0601	60	43	M10	30	35	4	70	12.0
61110.W0602	60	60	M10	30	51	6	150	30.0
61110.W0700	70	56	M12	35	50	6	220	45.0
61110.W0800	80	65	M12	35	70	8	400	55.0
61110.W0900	90	50	M12	45	80	4	800	65.0
61110.W1300	130	96	M16	45	115	13	1400	70.0



Anti-vibration Cylinders

female:female

Anti-Vibration



61080

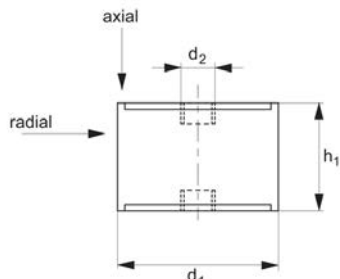

ANTI-VIBRATION

Material

Rubber on silver zinc plated steel (rubber hardness - 55 Shore A).

Tips

These cylinders are used to reduce vibra-

tion by allowing some movement (in axial and radial as shown).

Typically used in machinery, compressors, air conditioning units, light engineering equipment etc.

Order No.	Compression max.	d ₁	h ₁	d ₂	Axial load kgf max.	Radial load N max.
61080.W0151	3.0	15	15	M 4	13	3
61080.W0152	4.0	15	20	M 4	10	3
61080.W0153	4.5	15	22	M 4	10	2.5
61080.W0154	5.0	15	25	M 4	9	2
61080.W0155	5.5	15	28	M 4	9	2
61080.W0201	4.0	20	20	M 6	25	4
61080.W0202	5.0	20	25	M 6	25	5
61080.W0203	7.0	20	30	M 6	25	3
61080.W0204	8.0	20	35	M 6	16	2
61080.W0251	4.0	25	20	M 6	50	8
61080.W0252	5.0	25	25	M 6	40	8
61080.W0253	6.0	25	30	M 6	30	8
61080.W0254	8.0	25	35	M 6	35	9
61080.W0301	4.0	30	20	M 8	90	11
61080.W0302	5.0	30	25	M 8	85	10
61080.W0303	6.0	30	30	M 8	80	10
61080.W0351	8.5	35	40	M 8	60	13
61080.W0401	8.0	40	30	M 8	150	18
61080.W0402	10.0	40	40	M 8	120	18
61080.W0403	12.5	40	50	M 8	80	18
61080.W0501	8.0	50	30	M10	250	29
61080.W0502	10.0	50	40	M10	220	29
61080.W0503	12.0	50	50	M10	200	28
61080.W0601	7.0	60	35	M10	350	39
61080.W0602	10.0	60	45	M10	300	42
61080.W0603	11.0	60	50	M10	285	42
61080.W0751	9.0	75	40	M12	500	72
61080.W0702	10.0	70	50	M10	350	52
61080.W0703	10.5	70	55	M10	230	52
61080.W0752	11.5	75	50	M12	330	65
61080.W0753	13.0	75	55	M12	450	65



Order No.	Compression max.	d ₁	h ₁	d ₂	Axial load kgf max.	Radial load N max.
61080.W0801	15.0	80	70	M14	550	65
61080.W0901	8.0	100	40	M16	1200	95
61080.W0902	16.0	100	55	M16	775	97
61080.W0903	15.0	100	60	M16	1100	97
61080.W0904	16.0	100	100	M16	500	80
61080.W0931	6.0	130	40	M16	1900	120
61080.W0932	11.0	130	60	M16	680	100

ANTI-VIBRATION



Anti-vibration Cylinders Waisted female:female

Anti-Vibration

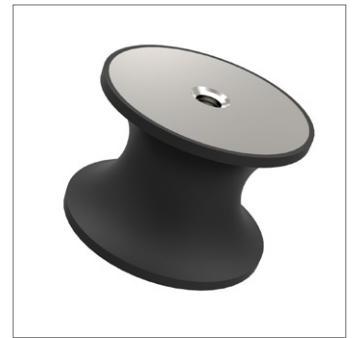
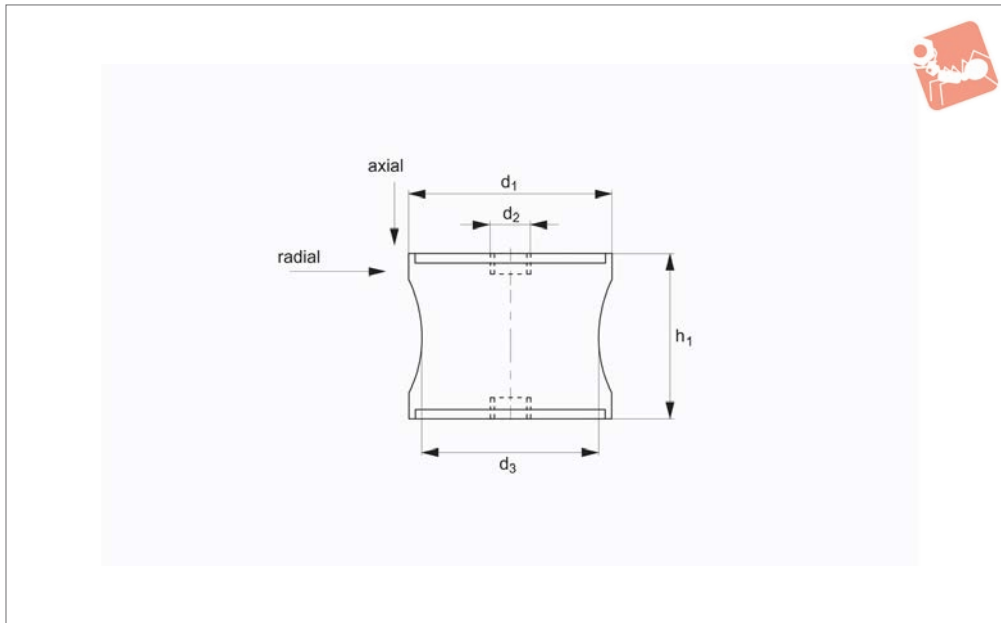

61102

ANTI-VIBRATION

Material

Rubber on silver zinc plated steel (rubber hardness - 55 Shore A).

Technical Notes

For rubber mounted on stainless steel see

part no. 61104

Tips

These cylinders are used to reduce vibration by allowing some movement (in axial and radial as shown in drawing).

Typically used in machinery, compressors, air conditioning units, light engineering equipment etc.

Order No.	Compression max.	d ₁	h ₁	d ₂	d ₃	Axial load kgf max.	Radial load kgf max.
61102.W0200	2.5	20	20	M 6	12	12	3.0
61102.W0300	4	30	25	M 8	24	40	4.0
61102.W0400	5	40	28	M10	22	30	2.5
61102.W0600	5	60	36	M10	37	40	7.0
61102.W0601	4	60	43	M10	35	75	12
61102.W0602	6	60	60	M10	51	150	30
61102.W0700	6	70	56	M12	50	220	45
61102.W0900	4	90	50	M12	80	800	65
61102.W0950	9.5	95	76	M12	80	400	70
61102.W1080	10	108	85	M16	95	800	75



61104

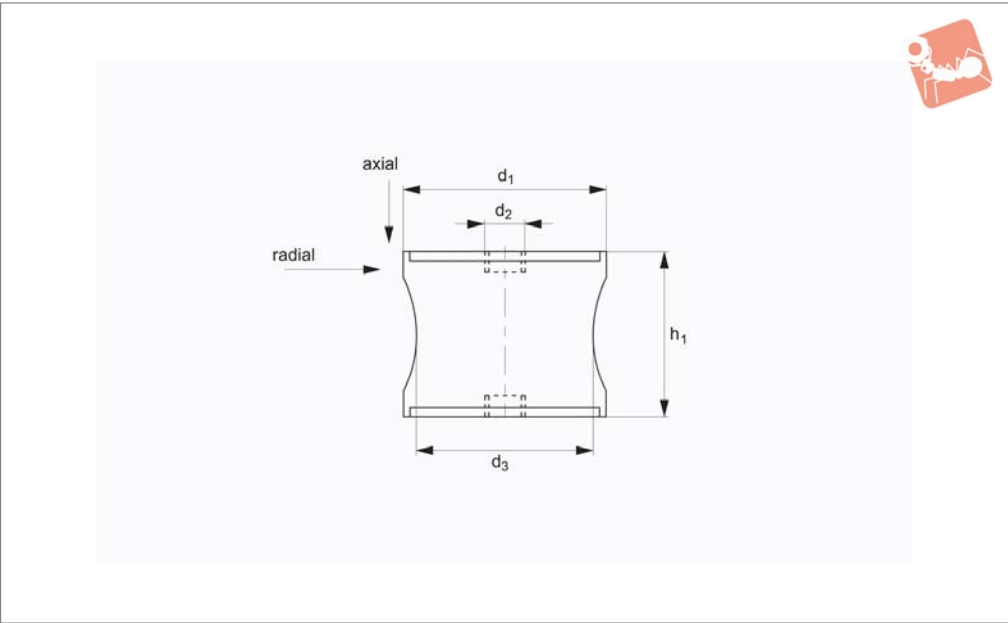

ANTI-VIBRATION

Material

Rubber on A2 stainless steel (rubber hardness - 55 Shore A).

Tips

These cylinders are used to reduce vibration by allowing some movement (in axial and shear as shown in drawing).

Typically used in machinery, compressors, air conditioning units, light engineering equipment etc.

Order No.	Compression max.	d ₁	h ₁	d ₂	d ₃	Axial load kgf max.	Radial load N max.
61104.W0600	5	60	36	M10	37	90	7
61104.W0601	6	60	60	M10	51	150	30
61104.W0700	6	70	56	M12	50	220	45
61104.W0900	7	90	77	M12	79	500	70
61104.W1080	10	108	85	M16	95	800	75



61200

ANTI-VIBRATION

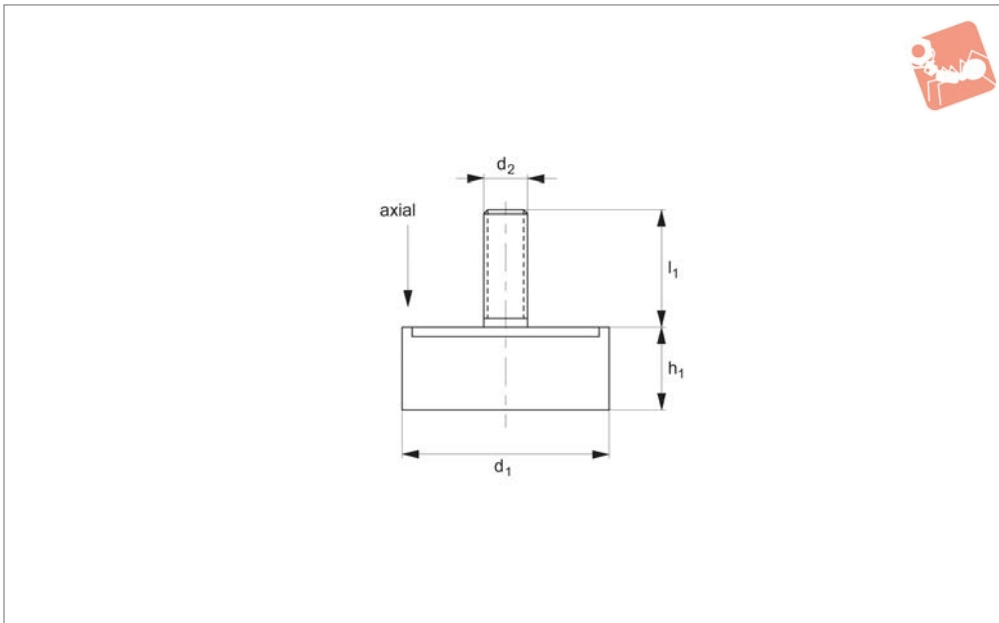

Material

Rubber on silver zinc plated steel (rubber hardness - 55 Shore A).

Tips

These feet or bumpers reduce shock and vibration.

Used widely as shock absorbers and feet for machine elements.

Order No.	d ₁	h ₁	d ₂	l ₁	Compression max.	Axial load kgf max.
61200.W0091	9	12	M 4	14	2.0	6
61200.W0151	15	10	M 4	14	1.5	13
61200.W0152	15	15	M 4	14	3.0	13
61200.W0153	15	20	M 4	14	4.0	10
61200.W0154	15	25	M 4	14	5.0	9
61200.W0201	20	10	M 6	13	2.0	30
61200.W0202	20	20	M 6	13	4.0	25
61200.W0251	25	10	M 6	18	1.5	50
61200.W0252	25	13	M 6	18	3.0	46
61200.W0253	25	15	M 6	18	3.0	44
61200.W0254	25	17	M 6	18	3.0	42
61200.W0255	25	20	M 6	18	4.0	41
61200.W0256	25	25	M 6	18	5.0	40
61200.W0257	25	30	M 6	18	6.0	35
61200.W0302	30	12	M 8	23	2.0	58
61200.W0303	30	15	M 8	20	3.0	58
61200.W0304	30	20	M 8	20	4.0	55
61200.W0305	30	25	M 8	20	5.0	50
61200.W0306	30	30	M 8	20	6.0	47
61200.W0351	35	11.5	M10	48	3.0	80
61200.W0352	35	40	M 8	23	8.0	68
61200.W0401	40	12	M 8	23	3.0	120
61200.W0402	40	20	M 8	23	4.0	117
61200.W0403	40	25	M 8	20	6.0	117
61200.W0404	40	30	M 8	20	8.0	100
61200.W0405	40	40	M 8	20	10.0	85
61200.W0406	40	45	M 8	20	12.0	85
61200.W0451	45	30	M 8	23	8.0	110
61200.W0452	45	50	M 8	35	12.0	85
61200.W0501	50	10	M10	28	2.0	230
61200.W0502	50	20	M10	25	4.0	250
61200.W0503	50	25	M10	25	5.5	250
61200.W0504	50	30	M10	25	8.0	150
61200.W0505	50	35	M10	25	9.0	230

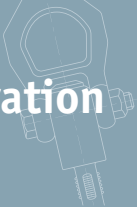

ANTI-VIBRATION

Order No.	d ₁	h ₁	d ₂	l ₁	Compression max.	Axial load kgf max.
61200.W0506	50	45	M10	25	11.0	130
61200.W0507	50	50	M10	25	12.0	125
61200.W0508	50	60	M10	28	14.0	110
61200.W0601	60	20	M10	28	4.0	280
61200.W0602	60	30	M10	28	8.0	280
61200.W0603	60	45	M10	30	10.0	190
61200.W0604	60	50	M12	37	11.0	185
61200.W0605	60	60	M10	30	12.0	185
61200.W0702	70	50	M12	35	10.0	250
61200.W0703	70	55	M12	35	12.0	240
61200.W0704	70	70	M10	30	13.0	300
61200.W0751	75	25	M12	35	5.0	295
61200.W0752	75	30	M12	37	8.0	320
61200.W0753	75	40	M12	35	9.0	320
61200.W0754	75	45	M12	35	10.0	500
61200.W0755	75	55	M12	35	13.0	450
61200.W0801	80	30	M14	35	5.5	900
61200.W0802	80	40	M14	35	9.0	600
61200.W0803	80	50	M14	35	10.0	750
61200.W0804	80	70	M14	35	15.0	550
61200.W1005	100	100	M16	56	19.0	500
61200.W1101	110	124	M12	37	19.0	550
61200.W1301	130	40	M16	45	6.0	550
61200.W1305	130	50	M16	45	9.0	550
61200.W1302	130	60	M16	56	14.0	680
61200.W1303	130	75	M16	45	13.0	1450
61200.W1304	130	100	M16	45	16.0	1200
61200.W1501	150	50	M20	20	9.0	1800
61200.W1502	150	60	M20	20	14.0	2200
61200.W1503	150	75	M20	20	16.0	2000
61200.W1504	150	100	M20	20	16.0	1400
61200.W1505	150	120	M20	20	16.0	1300
61200.W1506	150	140	M20	20	16.0	1200
61200.W0951	95	40	M16	45	8.0	1200
61200.W0952	95	55	M16	45	11.0	1000
61200.W0953	95	60	M16	45	12.0	800
61200.W0954	95	75	M16	45	13.0	700
61200.W1001	100	40	M16	45	8.0	660
61200.W1002	100	50	M16	56	10.0	550
61200.W1003	100	55	M16	56	11.0	520
61200.W0805	80	80	M14	50	18.0	370
61200.W1004	100	60	M16	45	15.0	515



Anti-vibration Feet female

Anti-Vibration

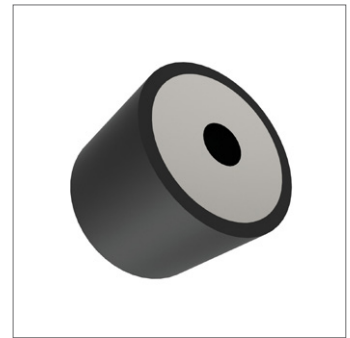

61202

ANTI-VIBRATION

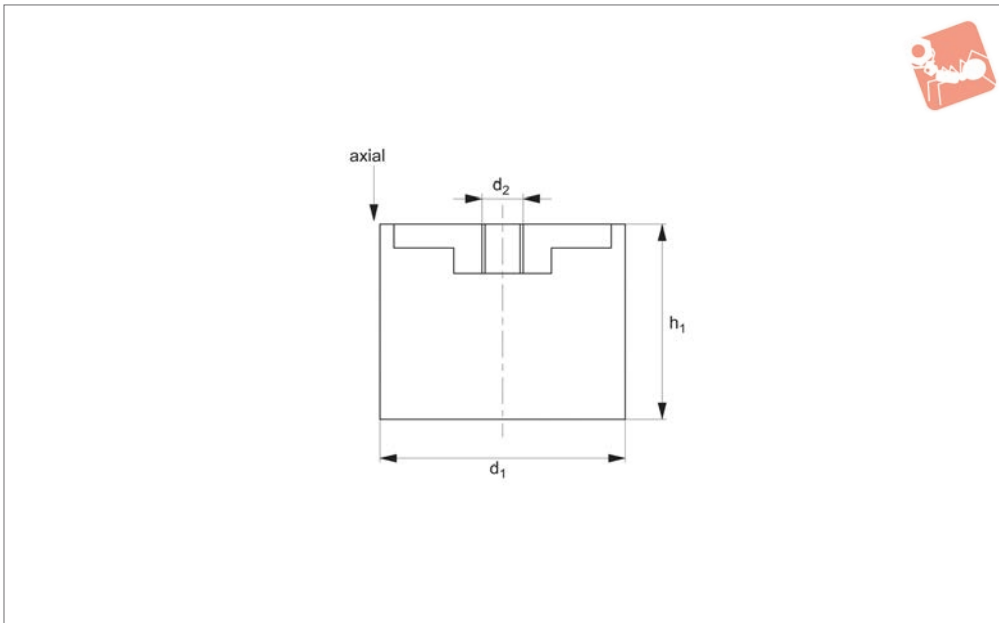

Material

Rubber on silver zinc plated steel (rubber hardness - 55 Shore A).

Tips

These feet or bumpers reduce shock and vibration.

Used widely as shock absorbers and feet for machine elements.

Order No.	d ₁	h ₁	d ₂	Compression max.	Axial load kgf max.
61202.W0100	10	10	M 4	2	10
61202.W0101	10	15	M 4	3	8
61202.W0130	13	10	M 5	1.5	12
61202.W0131	13	15	M 5	3	10
61202.W0132	13	20	M 5	3.5	20
61202.W0160	16	8	M 5	1.5	15
61202.W0161	16	10	M 5	1.5	20
61202.W0162	16	15	M 5	3	20
61202.W0163	16	20	M 5	4	20
61202.W0164	16	25	M 5	5	15
61202.W0200	20	10	M 6	2	30
61202.W0201	20	15	M 6	3	25
61202.W0202	20	20	M 6	4	25
61202.W0203	20	25	M 6	5	25
61202.W0204	20	30	M 6	7	25
61202.W0250	25	10	M 6	1.5	50
61202.W0251	25	15	M 6	3	50
61202.W0252	25	20	M 6	4	50
61202.W0253	25	22	M 6	4	45
61202.W0254	25	25	M 6	5	40
61202.W0256	25	30	M 6	6	35
61202.W0300	30	10	M 8	2	90
61202.W0301	30	15	M 8	3	90
61202.W0302	30	20	M 8	4	90
61202.W0303	30	22	M 8	4	90
61202.W0304	30	25	M 8	5	85
61202.W0305	30	30	M 8	6	80
61202.W0306	30	40	M 8	8	60
61202.W0350	35	35	M 8	8	90
61202.W0400	40	20	M 8	4	160
61202.W0401	40	25	M 8	6	155
61202.W0402	40	28	M 8	6	150
61202.W0403	40	30	M 8	8	150
61202.W0404	40	35	M 8	8	120



ANTI-VIBRATION

Order No.	d ₁	h ₁	d ₂	Compression max.	Axial load kgf max.
61202.W0405	40	40	M 8	10	120
61202.W0406	40	45	M 8	12	110
61202.W0504	50	40	M10	10	220
61202.W0505	50	45	M10	11	210
61202.W0506	50	50	M10	12	200
61202.W0507	50	55	M10	13	200
61202.W1001	100	60	M16	15	1100
61202.W1002	100	75	M16	17	1000
61202.W1200	120	50	M16	9	1500
61202.W1201	120	75	M16	13	1200
61202.W1202	120	100	M16	16	1000
61202.W1300	130	40	M16	6	1900
61202.W1301	130	50	M16	9	1600
61202.W1302	130	75	M16	13	1450
61202.W1303	130	100	M16	16	1200
61202.W1500	150	40	M20	9	1800
61202.W1501	150	60	M20	14	2200
61202.W1502	150	75	M20	16	2000
61202.W1503	150	100	M20	16	1400
61202.W1504	150	120	M20	16	1300
61202.W1505	150	140	M20	16	1200
61202.W0500	50	20	M10	4	250
61202.W0501	50	25	M10	5.5	250
61202.W0502	50	30	M10	8	250
61202.W0503	50	35	M10	9	230
61202.W0752	75	45	M12	10	500
61202.W0602	60	45	M10	10	300
61202.W0802	80	50	M14	10	750
61202.W0702	70	70	M10	13	300
61202.W0753	75	55	M12	13	450
61202.W0803	80	70	M14	15	550
61202.W0950	95	40	M16	8	1200
61202.W0951	95	55	M16	11	1000
61202.W0952	95	60	M16	12	800
61202.W0953	95	75	M16	13	700
61202.W0603	60	60	M10	12	250
61202.W0700	70	35	M10	7	450
61202.W0750	75	25	M12	5	650
61202.W0600	60	25	M10	5	400
61202.W0601	60	35	M10	7	350
61202.W0800	80	30	M14	5.5	900
61202.W0801	80	40	M14	9	600
61202.W0751	75	40	M12	9	500
61202.W1000	100	40	M16	8	1200
61202.W0701	70	50	M10	10	350



Anti-vibration Cylinders Waisted male feet

Anti-Vibration

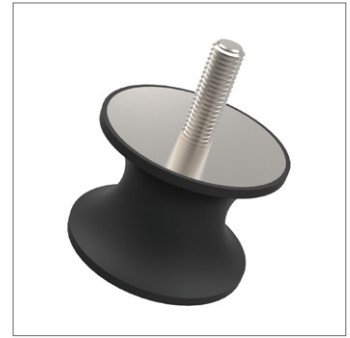

61206

ANTI-VIBRATION

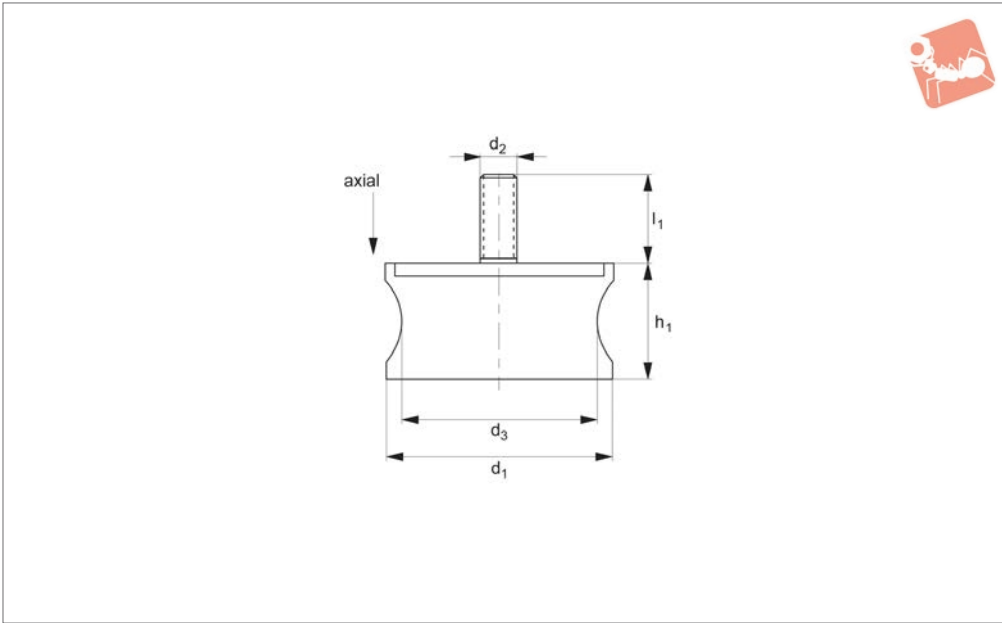

Material

Rubber on silver zinc plated steel (rubber hardness - 55 Shore A).

Tips

These cylinders are used to reduce vibra-

tion by allowing some movement (in axial and radial as shown in drawing).

Typically used in machinery, compressors, air conditioning units, light engineering equipment etc.

Order No.	d ₁	h ₁	d ₂	d ₃	l ₁	Compression max.	Axial load kgf max.
61206.W0200	20	20	M 6	12	18	2.5	15
61206.W0300	30	25	M 8	24	20	4	40
61206.W0400	40	28	M10	22	25	5	60
61206.W0600	60	36	M10	37	30	5	90
61206.W0601	60	43	M10	35	30	4	70
61206.W0602	60	60	M10	51	30	6	150
61206.W0700	70	56	M12	50	35	6	220
61206.W0800	80	65	M12	70	35	8	400
61206.W0900	90	50	M12	80	45	4	800
61206.W0950	95	76	M16	80	45	9.5	400
61206.W1080	108	85	M16	95	45	10	800



61210

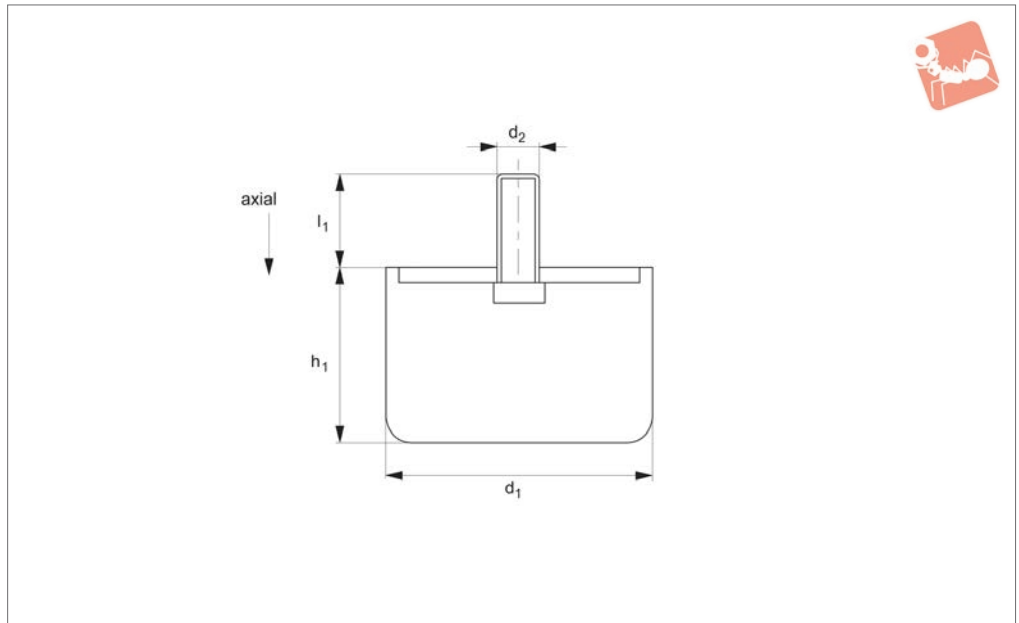

Material

Rubber on silver zinc plated steel (rubber hardness - 55 Shore A).

Tips

These anti-vibration bumpers are used to reduce vibration and shock. Their cylindrical shape ensures that when used in a

row, the buffers spread the loads over a number of buffers - reducing the chances of possible overloading.

Order No.	d ₁	h ₁	d ₂	l ₁	Compression max.	Axial load kgf max.
61210.W0040	40	32	M 8	30	14	850
61210.W0050	50	40	M10	25	17	1270
61210.W0063	63	50	M10	25	20	1950
61210.W0080	80	63	M12	24	25	3250
61210.W1000	100	80	M12	27	30	4900
61210.W1250	125	100	M16	45	40	7800
61210.W1600	160	125	M16	45	52	12300
61210.W2000	200	160	M20	49	65	19100
61210.W2500	250	200	M20	49	80	30500



Anti-vibration Bumpers flanged

Anti-Vibration

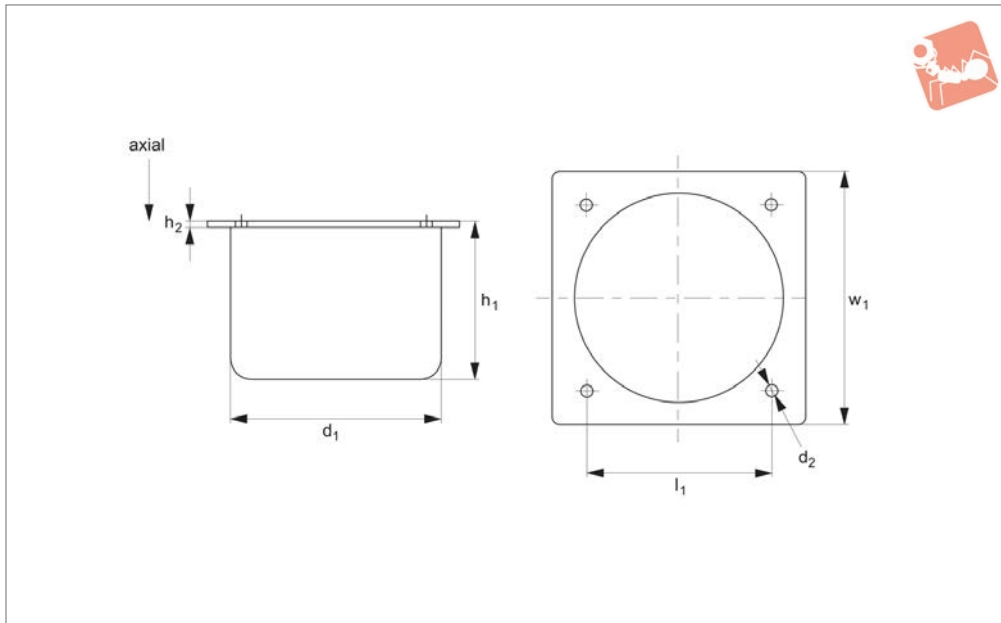

61250

ANTI-VIBRATION

Material

Rubber on silver zinc plated steel (rubber hardness - 55 Shore A).

Tips

These anti-vibration bumpers are used to reduce vibration and shock. Their cylindrical shape ensures that, when used in a

row, the buffers spread loads over a number of buffers - reducing the chances of possible overloading.

Order No.	d ₁	h ₁	d ₂	l ₁	w ₁	h ₂	Axial load kgf max.	Momentum kg·m/s	Deflection m/m max.
61250.W0400	40	32	5.5	40	50	3	850	5	14
61250.W0500	50	40	6.5	50	63	4	1270	10	17
61250.W0630	63	50	6.5	63	80	6	1950	20	20
61250.W0800	80	63	9.0	80	100	6	3250	40	25
61250.W1000	100	80	9.0	100	125	8	4900	80	30
61250.W1250	125	100	11.0	125	160	8	7800	160	40
61250.W1600	160	125	11.0	160	200	10	15000	320	50
61250.W2000	200	160	13.0	200	250	10	19100	630	65
61250.W2500	250	200	13.0	250	315	12	30500	1250	80



61240

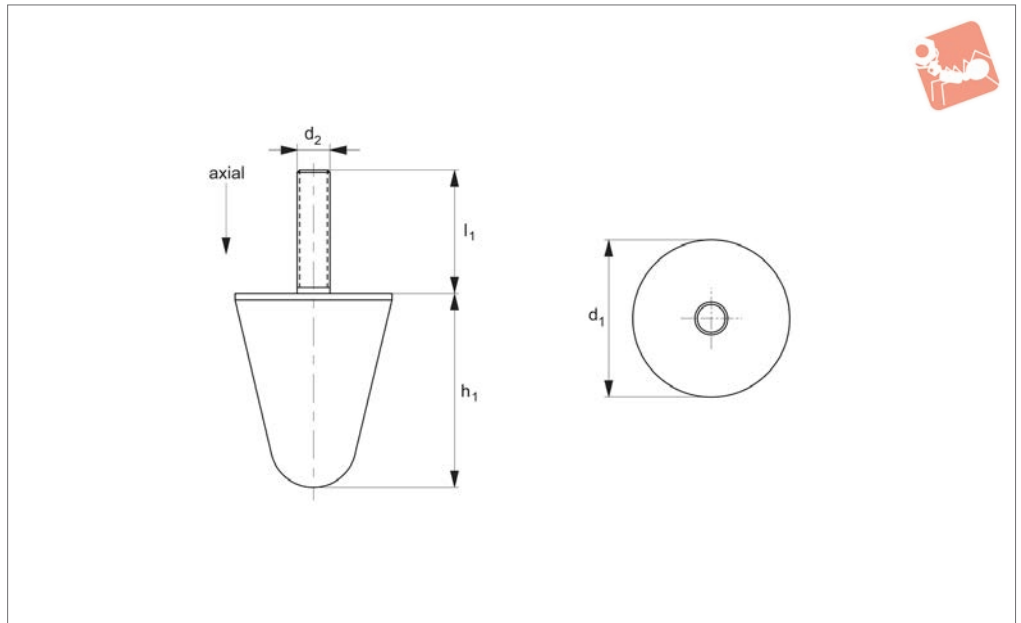

Material

Rubber on silver zinc plated steel (rubber hardness - 65 Shore A).

Tips

These anti-vibration cones or bumpers are

used to reduce vibration and shock. Their conical shape ensures that, when used in a row, the buffers spread loads over a number of cones - reducing the chances of possible overloading.

Important Notes

The working load should not exceed 65% of the maximum load.

Order No.	d ₁	h ₁	d ₂	l ₁	Axial load kgf max.
61240.W0200	20	20	M 6	18	70
61240.W0250	25	20	M 8	20	100
61240.W0300	30	30	M 6	17	150
61240.W0301	30	30	M 8	20	150
61240.W0400	40	30	M 8	23	240
61240.W0401	40	50	M 8	23	200
61240.W0500	50	48	M10	25	380
61240.W0501	50	58	M 8	20	400
61240.W0502	50	64	M 8	35	370
61240.W0630	63	60	M12	37	440
61240.W0750	75	90	M12	37	520
61240.W0900	90	74	M16	45	1100
61240.W0950	95	82	M16	45	1100

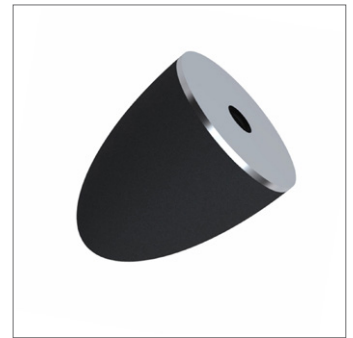
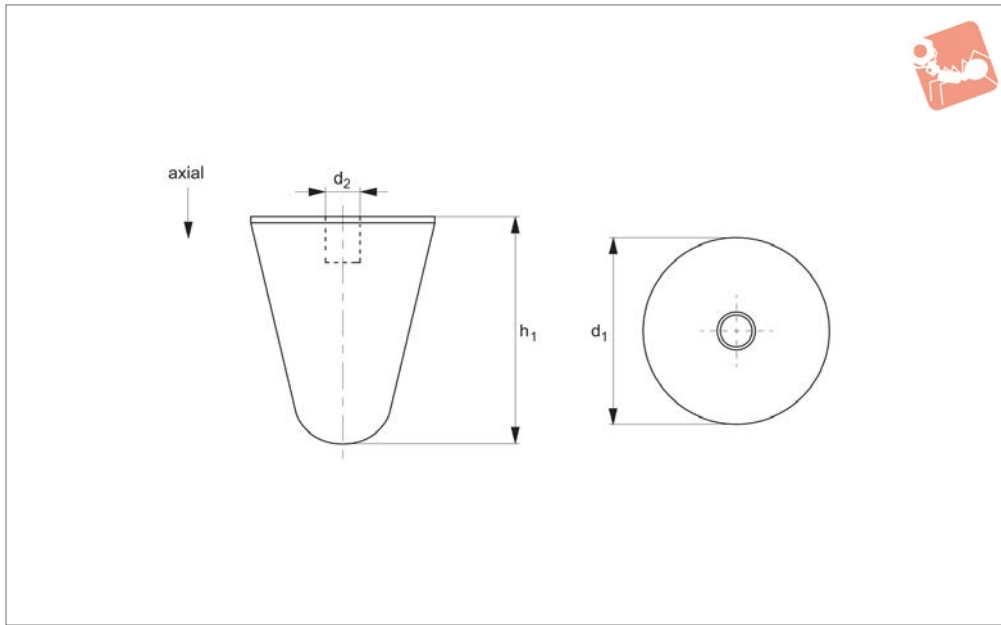

61242

ANTI-VIBRATION

Material

Rubber on silver zinc plated steel (rubber hardness - 65 Shore A).

Tips

These anti-vibration cones or bumpers are

used to reduce vibration and shock. Their conical shape ensures that when used in a row, the buffers spread loads over a number of cones - reducing the chances of possible overloading.

Important Notes

The working load should not exceed 65% of the maximum load.

Order No.	d ₁	h ₁	d ₂	Axial load kgf max.
61242.W0200	20	20	M 6	70
61242.W0250	25	20	M 8	100
61242.W0300	30	30	M 6	150
61242.W0500	50	48	M10	380
61242.W0700	70	60	M12	550
61242.W0900	90	74	M16	1100
61242.W0950	95	82	M16	1100

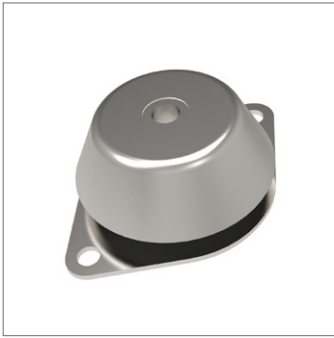

61280

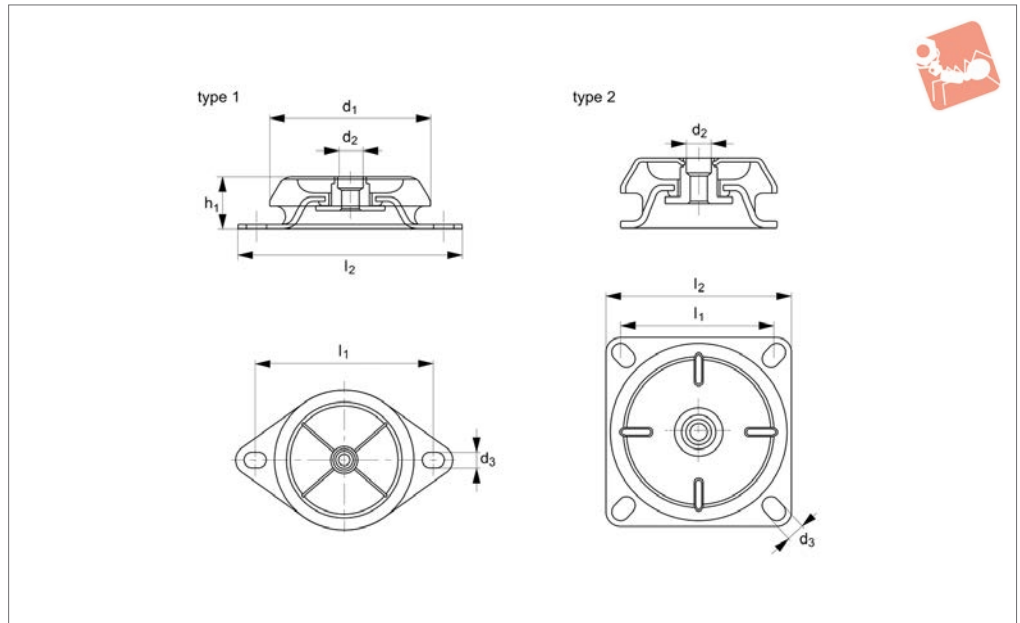

Material

Rubber on silver zinc plated steel (rubber hardness - 60 Shore A).

Technical Notes

Provides an elastic support mechanism for equipment isolation. Used in generator sets, motors, pumps and most other

machine parts.

Please note for marine applications or very demanding use we recommend the mounts with ,fail-safe' features part numbers P2100, 61292 and 61294.

Tips

These are a very popular anti-vibration

mount for light to heavy duty applications.

Take the total weight of the load to be supported, divide it by the number of mounts to be used and select an appropriate mount from the above table. Type 2 is ,fail-safe'.

Order No.	Type	d ₁	d ₂	d ₃	h ₁	l ₁	l ₂	Axial load kgf max.	Shore
61280.W0504	Type 1	50	M 8	6.5	25	61-70	85	20	40
61280.W0505	Type 1	50	M 8	6.5	25	61-70	85	40	50
61280.W0506	Type 1	50	M 8	6.5	25	61-70	85	60	60
61280.W0604	Type 1	64	M10	9.0	35	76-91	110	30	40
61280.W0605	Type 1	64	M10	9.0	35	76-91	110	45	50
61280.W0606	Type 1	64	M10	9.0	35	76-91	110	65	60

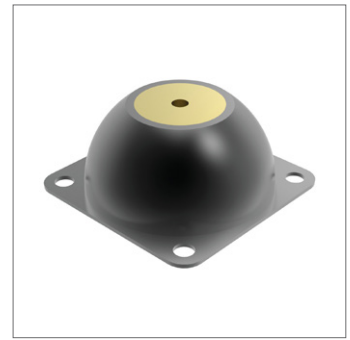
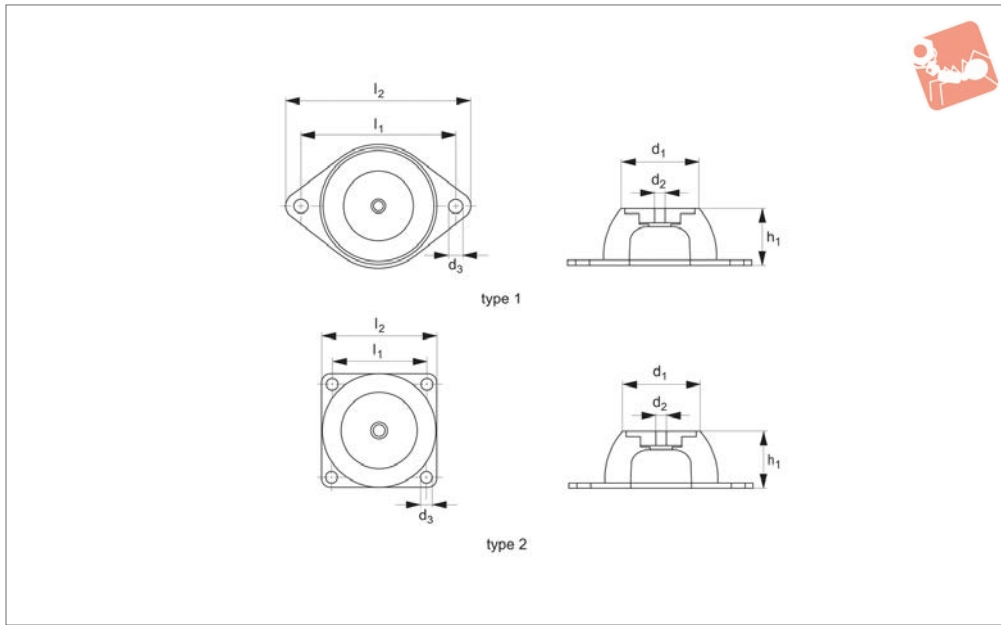

61345

ANTI-VIBRATION

Material

Rubber on yellow zinc plated steel (rubber hardness 45-65 Shore A).

for machines that move in three directions. Oil anti-drip hoods can be supplied on request.

air conditioners, ventilators and vibrating tables.

Technical Notes

The design of the mount makes them ideal

Tips

These mounts are found on compressors,

Order No.	Type	d ₁	d ₂	d ₃	h ₁	h ₂	l ₁	l ₂	Load kgf max.	Weight g
61345.W0450	Type 1	33.0	M 8	8.0	25	2.0	66	85	20	70
61345.W0451	Type 1	33.0	M 8	8.0	25	2.0	66	85	50	70
61345.W0650	Type 1	52.0	M10	10.5	35	2.5	92	114	40	170
61345.W0651	Type 1	66	M10	10.5	35	2.5	92	114	75	170
61345.W0850	Type 1	52.0	M10	11.5	40	3.0	110	136	75	303
61345.W0851	Type 1	52.0	M10	11.5	40	3.0	110	136	120	303
61345.W0900	Type 1	57.5	M10	12.5	45	3.0	125	150	130	430
61345.W0901	Type 1	57.5	M10	12.5	45	3.0	125	150	220	430
61345.W1300	Type 2	78.0	M12	14.5	63	5.0	120	150	280	1080
61345.W1301	Type 2	78.0	M12	14.5	63	5.0	120	150	500	1080
61345.W1700	Type 2	100	M16	14.5	84	4.0	160	200	380	2390
61345.W1701	Type 2	100	M16	14.5	84	4.0	160	200	750	2390
61345.W2500	Type 2	187	M24	18.5	158	6.0	250	310	1400	10400
61345.W2501	Type 2	187	M24	18.5	158	6.0	250	310	2500	10400

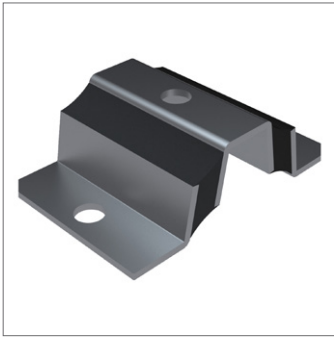

61510

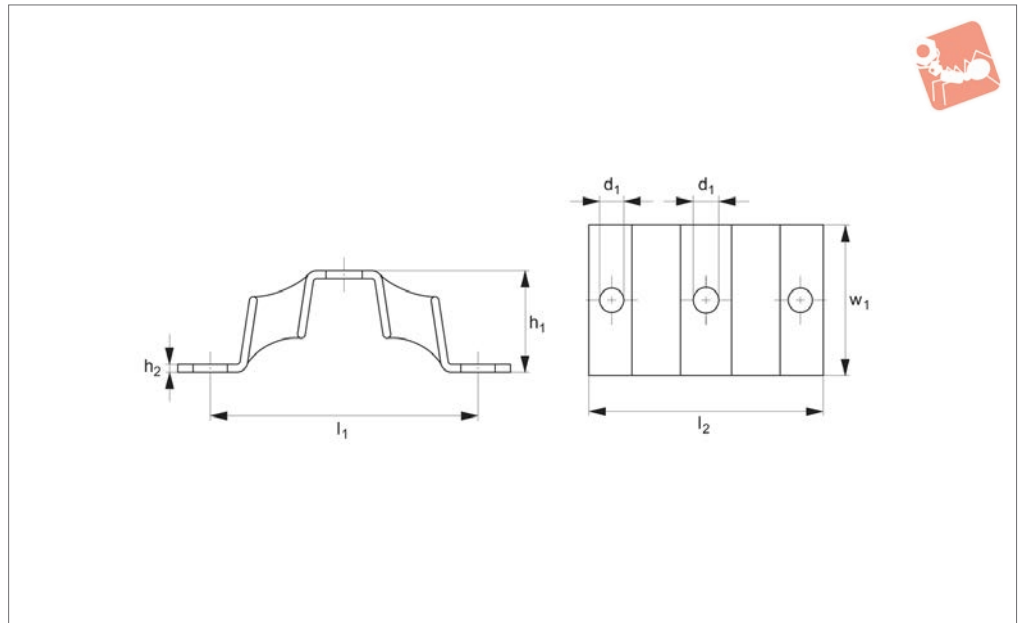

Material

Rubber on silver zinc plated steel (rubber hardness 45-65 Shore A).

Technical Notes

Has a three point anchorage, two to a base

and one to the piece of equipment. Very good as a shock/isolating mount for oscillations higher than 15Hz.

Tips

Can be used to hang compressors, speakers

and air conditioning units from the wall.

Order No.	Shore hardness	d ₁	Compression max.	h ₁	h ₂	l ₁	w ₁	l ₂	Axial load kgf max.	Radial load kgf max.
61510.W0045	45	12	2.5	35	3	90	73	112	60	60
61510.W0055	55	12	3.5	35	3	90	73	112	65	65
61510.W0065	65	12	6.0	35	3	90	73	112	70	70



Recommendations for machine mounts

Machine mounts should be installed between two parallel and perfectly flat surfaces. Mounts operating tilted or twisted do not work properly. This may be due to incorrect alignment, tolerances in the building of the structure or over-tightened torque during the installation of the anti-vibration mounts.

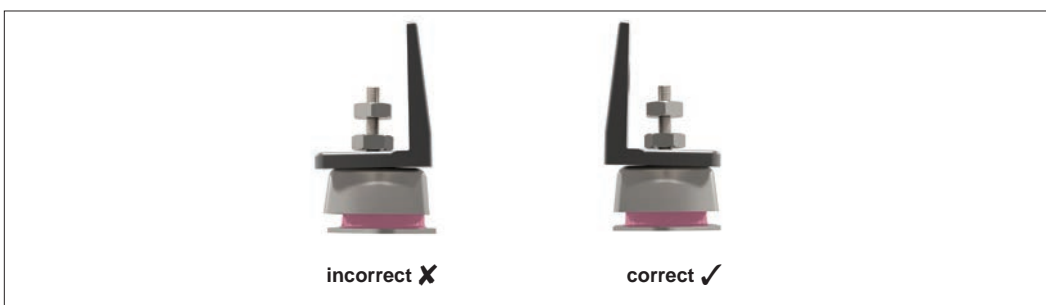
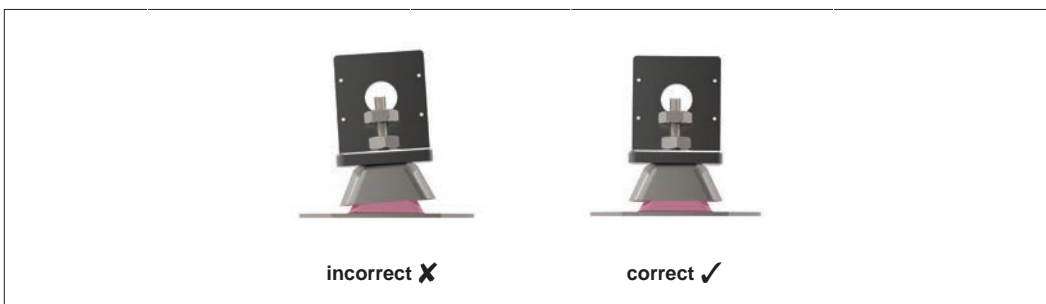
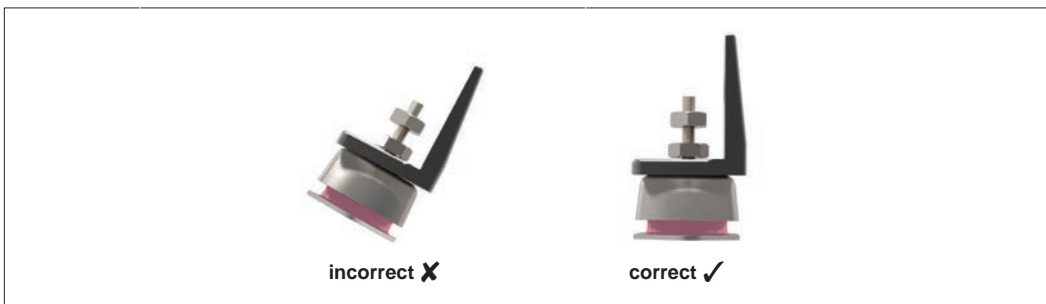
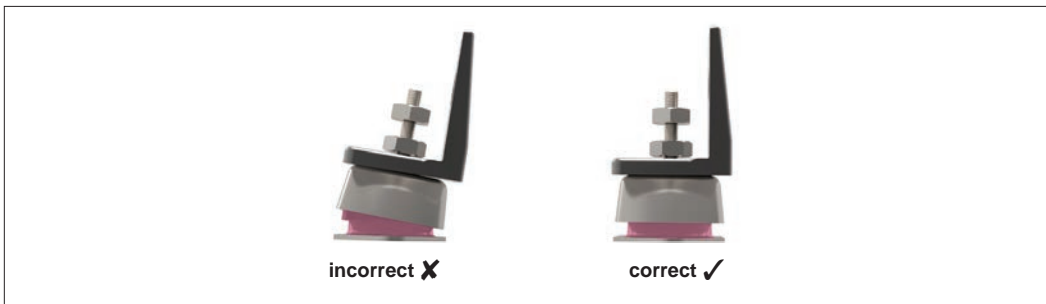
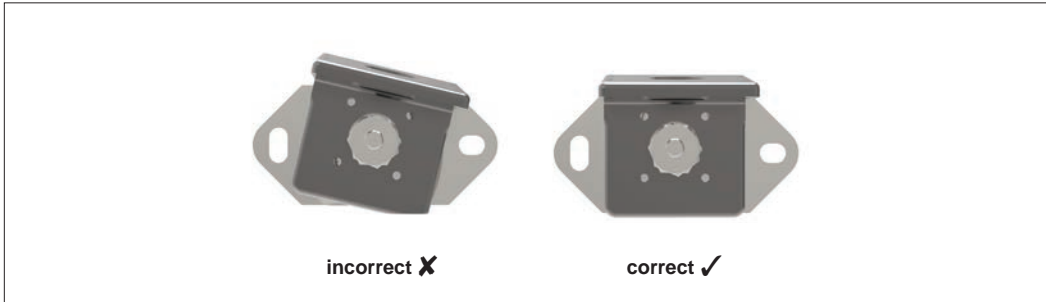

ov-W61280-AP2103-T-W61510-AP2107-T-a-mh- Updated -28-10-2022



ANTI-VIBRATION



61290

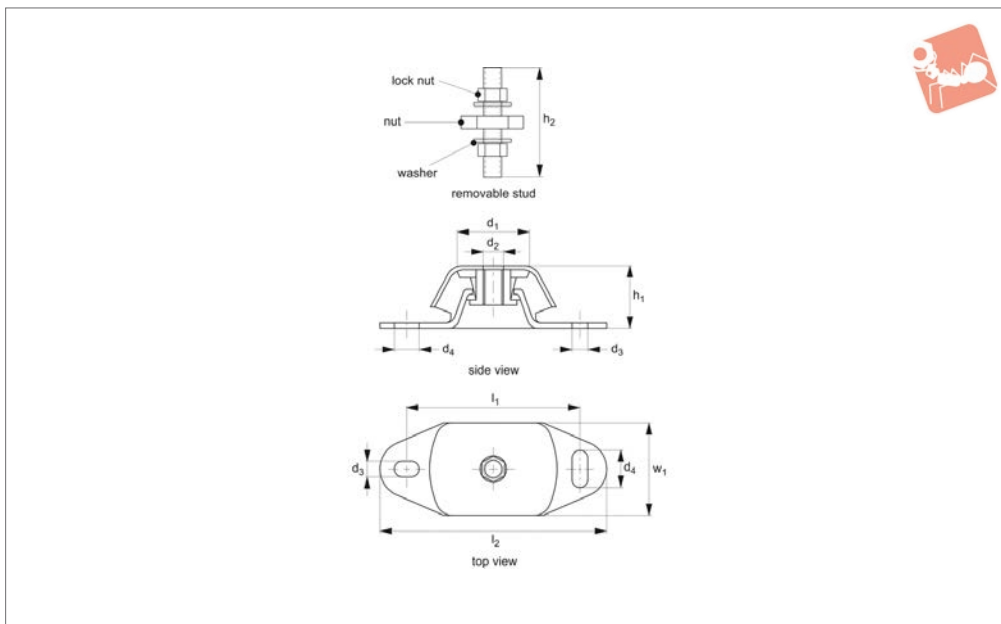

Material

Rubber on silver zinc plated steel (rubber hardness - 45-75 Shore A).

Technical Notes

These mounts control vibration in three axes.

Primarily used for marine applications, engines, compressors, pumps, generators

etc.

Fitted with a mechanical fail-safe stop. They are very robust to cope with high start/stop forces and vibrations from marine and other engines.

For stainless steel versions please see part nos. 61292 and 61294. Stud and nuts on

request.

Tips

These are a very popular anti-vibration mount for light to heavy duty applications. Take the total weight of the load to be supported, divide it by the number of mounts to be used and select an appropriate mount from the table.

Order No.	d ₁	d ₂	l ₁	l ₂	w ₁	d ₃	d ₄	h ₁	h ₂	Load N max.
61290.W0010	60	M12	100	120	60	11	14	40	95	50
61290.W0011	60	M12	100	120	60	11	14	40	95	65
61290.W0012	60	M12	100	120	60	11	14	40	95	100
61290.W0014	75	M16	140	183	75	13	20	50	110	150
61290.W0015	75	M16	140	183	75	13	20	50	110	200
61290.W0016	75	M16	140	183	75	13	20	50	110	300
61290.W0017	75	M16	140	183	75	13	20	50	110	550
61290.W0020	80	M20	182	230	112	18	25	70	110	750



Anti-vibration Fail-Safe Mounts

A2 stainless

Anti-Vibration

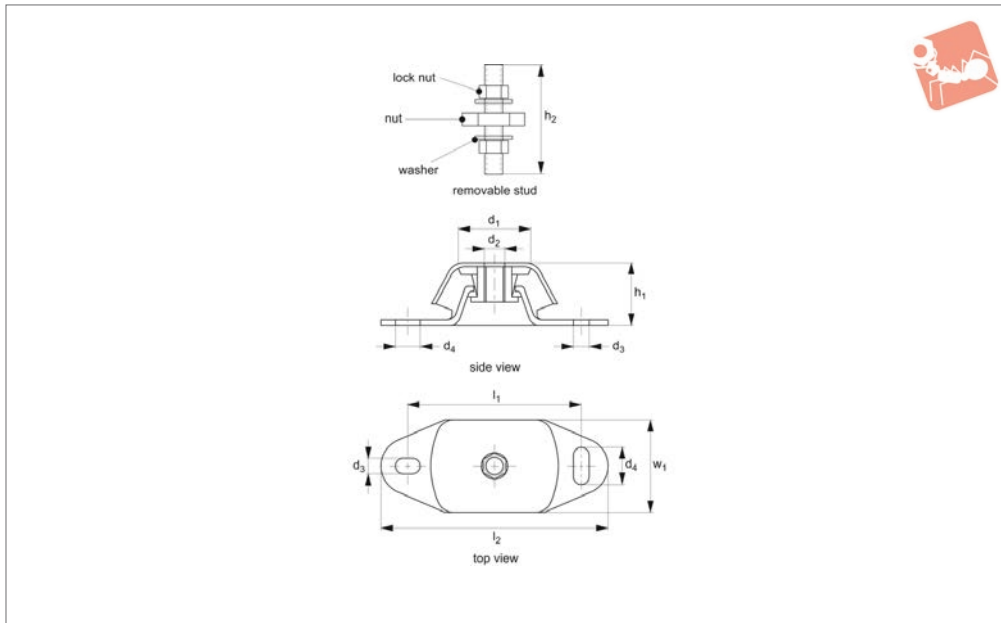

61292

ANTI-VIBRATION

Material

Stainless steel (AISI 304), (rubber hardness 45-65 Shore A).

Technical Notes

These mounts control vibration in three axes.

Primarily used for marine applications, engines, compressors, pumps, generators etc.

Fitted with a mechanical fail-safe stop. They are very robust to cope with high start/stop forces and vibrations from marine and other engines.

The stainless steel versions are widely used for marine engine mounts or outdoor applications. For offshore or highly corrosive environments use part no. 61294.

Stud and nuts on request.

Tips

These are a very popular anti-vibration mount for light to heavy duty applications. Take the total weight of the load to be supported, divide it by the number of mounts to be used and select an appropriate mount from the table.

Order No.	d ₁	d ₂	l ₁	l ₂	w ₁	d ₃	d ₄	h ₁	h ₂	Load N max.
61292.W0602	60	M12	100	120	60	11	14	40	95	100
61292.W0752	75	M16	140	183	75	13	20	50	110	300
61292.W0600	60	M12	100	120	60	11	14	40	95	50
61292.W0601	60	M12	100	120	60	11	14	40	95	65
61292.W0750	75	M16	140	183	75	13	20	50	110	150
61292.W0751	75	M16	140	183	75	13	20	50	110	200



ANTI-VIBRATION



61294

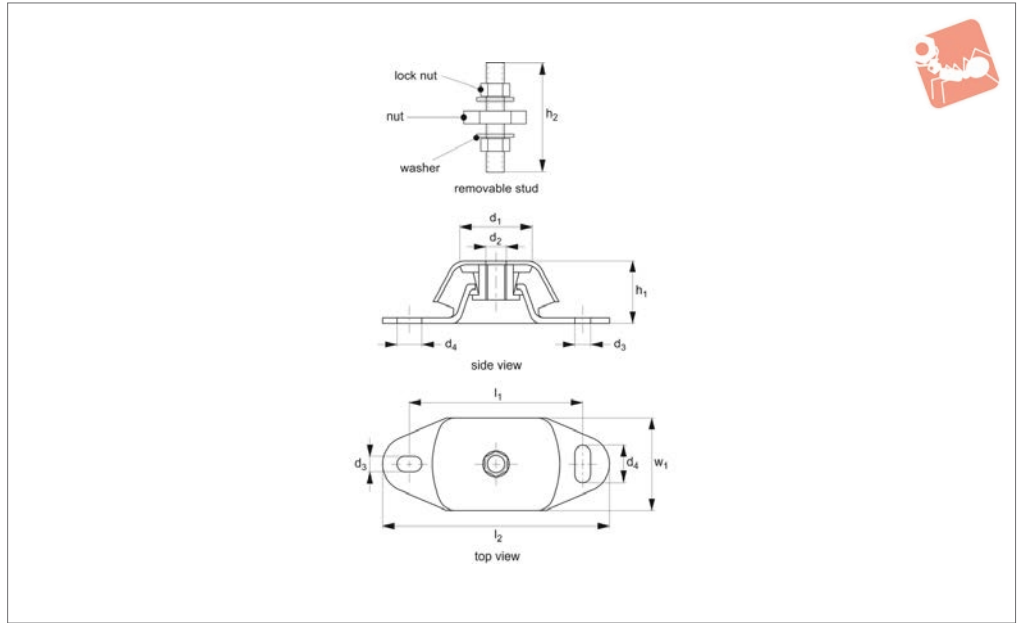

Material

Stainless steel (A4, 316). Rubber hardness 65-75 Shore A.

Technical Notes

These mounts control vibration in three axes.

Primarily used for marine applications, engines, compressors, pumps, generators etc.

Fitted with a mechanical fail-safe stop.

They are very robust to cope with high start/stop forces and vibrations from marine and other engines.

These stainless steel versions are widely used for marine engine mounts or applications that are either offshore or have a very high corrosion level. Stud and nuts on

request.

Tips

These are a very popular anti-vibration mount for light to heavy duty applications. Take the total weight of the load to be supported, divide it by the number of mounts to be used and select an appropriate mount from the table.

Order No.	d ₁	d ₂	l ₁	l ₂	w ₁	d ₃	d ₄	h ₁	h ₂	Load N max.
61294.W0600	60	M12	100	120	60	11	14	40	95	100
61294.W0750	75	M16	140	183	75	13	20	50	110	550

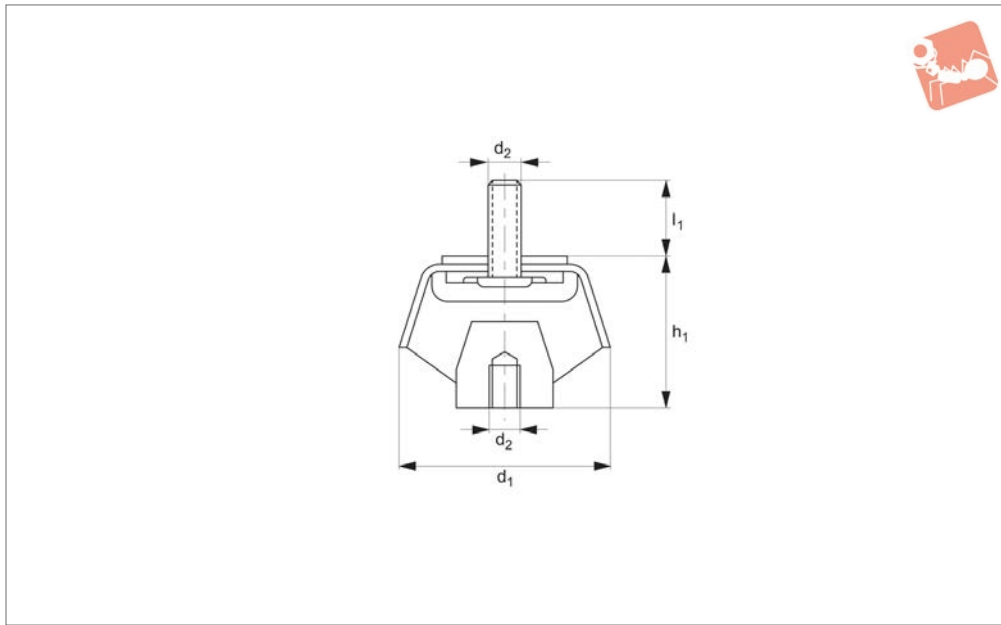

61340

ANTI-VIBRATION

Material

Rubber on silver zinc plated steel.

for supporting most applications, such as engine loads.

Technical Notes

With a bell-like base this unit is suitable

suspensions. It can also be used to carry horizontal

Order No.	Shore hardness	d ₁	l ₁	d ₂	h ₁	Load kgf max.
61340.W0050	50 A	55	23	M10	40	30
61340.W0060	60 A	55	23	M10	40	60
61340.W0070	70 A	55	23	M10	40	120



61350

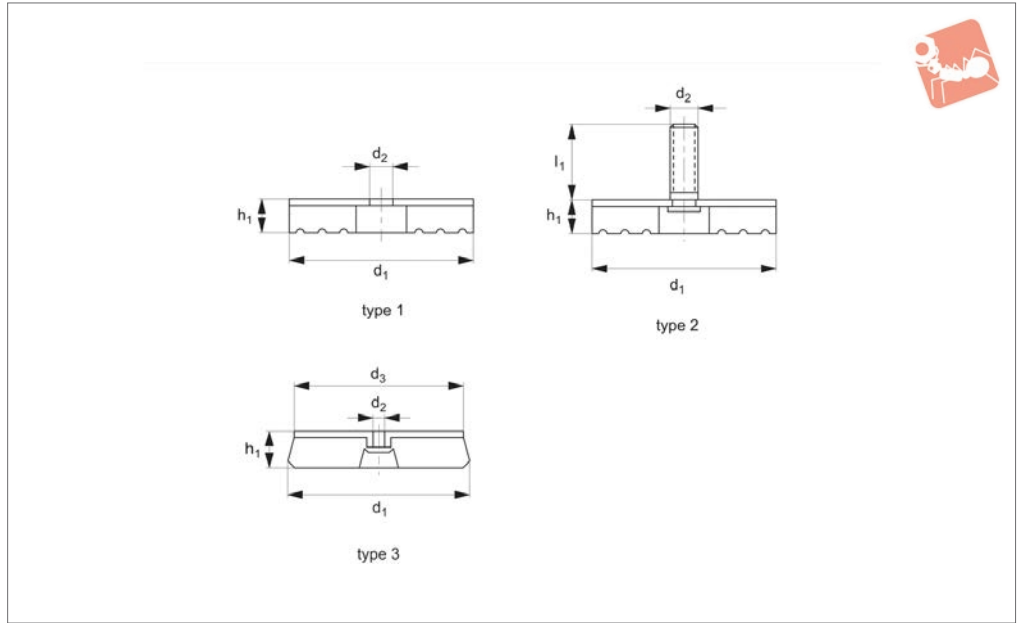

Material

Rubber on zinc plated steel.

Order No.	Type	d ₁	l ₁	d ₂	d ₃	h ₁	Compression max.	Static load kgf max.
61350.W0105	Type 1	50	-	10.5	-	15	2.2	180
61350.W0108	Type 1	85	-	10.5	-	15	1.6	450
61350.W0205	Type 2	55	25	M12	-	16	2.2	180
61350.W0208	Type 2	85	25	M12	-	16	1.6	450
61350.W0212	Type 2	125	25	M12	-	16	2.2	800
61350.W0305	Type 3	50	-	6.0	45	18	2	50
61350.W0309	Type 3	91	-	6.5	86	18	2	350
61350.W0313	Type 3	138	-	10.5	130	25	2.6	900

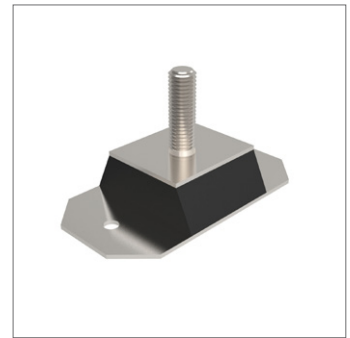
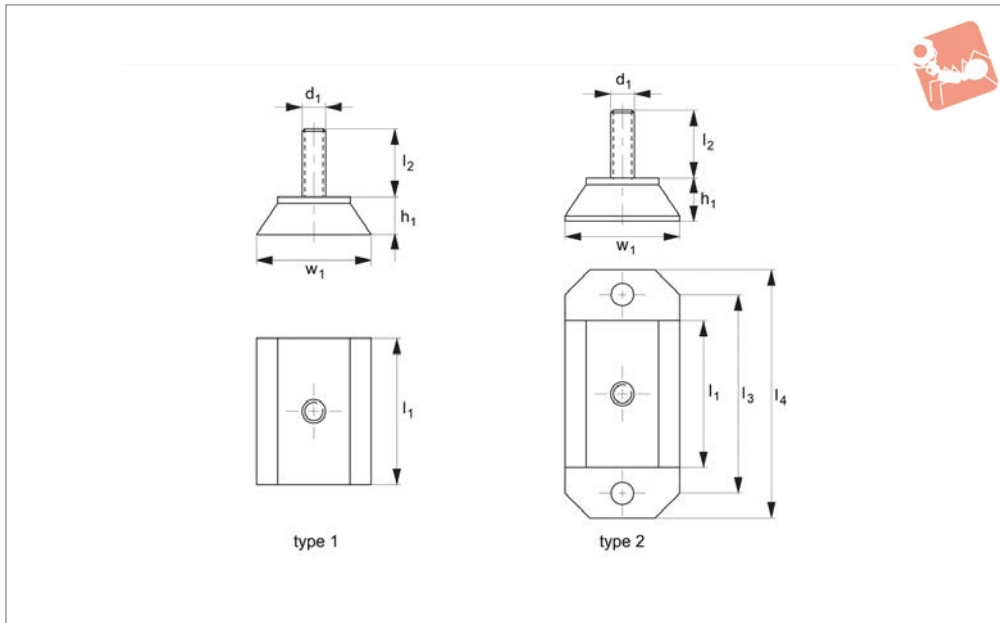

61460

ANTI-VIBRATION

Material

Rubber on silver zinc plated steel (rubber hardness - 55 Shore A).

Technical Notes

Used to support machine tools and packing machinery.

Provides vibration isolation for frequencies higher than 20Hz.

Order No.	Type	d ₁	l ₁	h ₁	l ₂	l ₃	l ₄	w ₁	Axial load kgf max.	Compression max.
61460.W0105	Type 1	M12	50	20	37	-	-	60	250	2
61460.W0110	Type 1	M12	100	20	37	-	-	60	500	2
61460.W0115	Type 1	M12	150	20	37	-	-	60	750	2
61460.W0120	Type 1	M12	200	20	37	-	-	60	1000	2
61460.W0205	Type 2	M12	50	23	37	85	115	60	250	2
61460.W0210	Type 2	M12	100	23	37	135	165	60	500	2
61460.W0215	Type 2	M12	150	23	37	185	215	60	750	2
61460.W0220	Type 2	M12	200	23	37	235	265	60	1000	2



61470

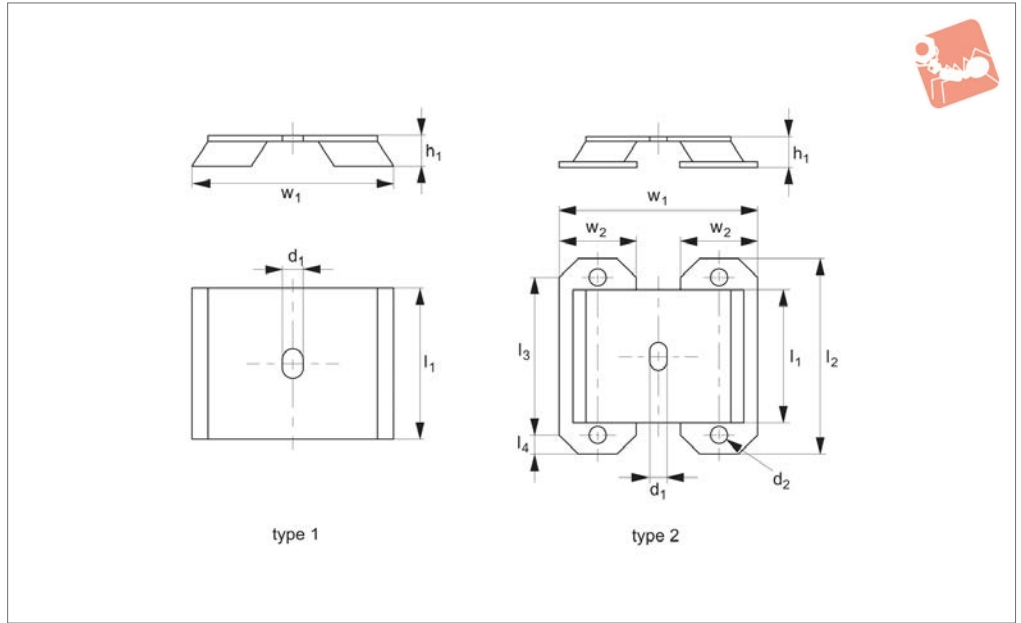

ANTI-VIBRATION

Material

Rubber on silver zinc plated steel (rubber hardness - 55 Shore A).

Technical Notes

Used where transverse loads are present.

Order No.	Type	d ₁	l ₁	h ₁	l ₂	l ₃	l ₄	w ₁	w ₂	Compression max.	Static load kgf max.
61470.W0100	Type 1	13	100	20	-	-	-	130	-	2	850
61470.W0150	Type 2	13	150	23	215	185	15	145	60	2	1300
61470.W0200	Type 2	13	200	23	265	235	15	145	60	2	1700

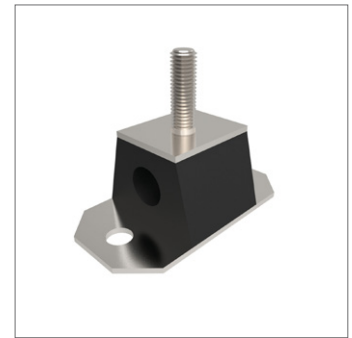
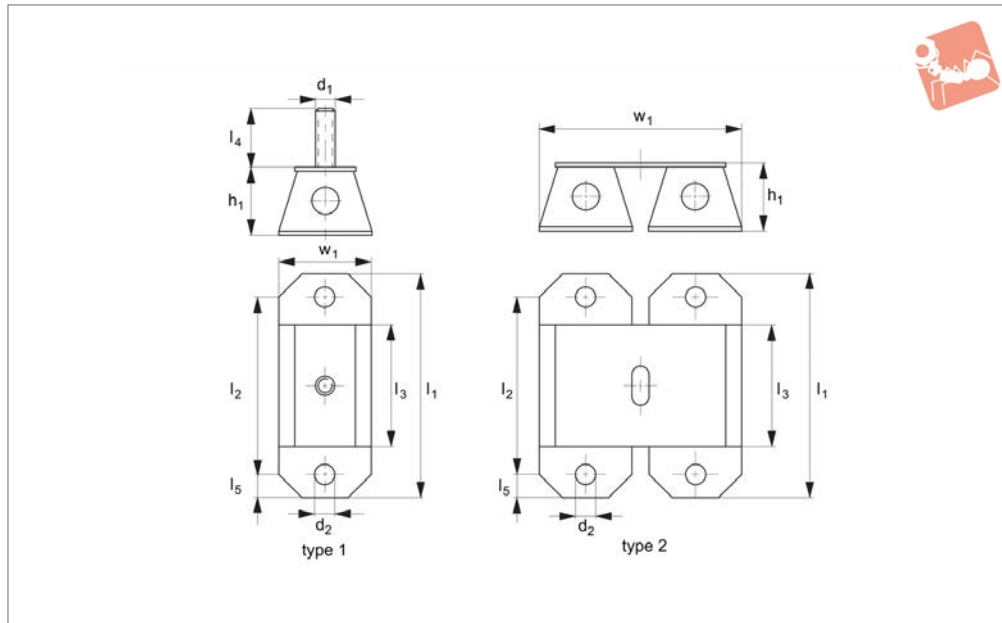
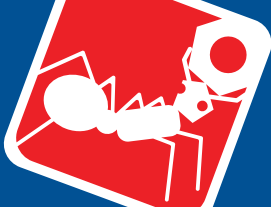

61480

ANTI-VIBRATION

Material

Rubber on silver zinc plated steel (rubber hardness - 55 Shore A).

Technical Notes

Type 1: M12 thread supplied as separate

item to be screwed in if required.

Type 2: A twin version of type 1 and so therefore take heavier loads.

The central hole in the rubber pad increases the flexibility of the unit - improving

anti-vibration properties.

Used where good deflection properties are needed and for isolating of frequencies higher than 10Hz.

Order No.	Type	d ₁	l ₁	d ₂	h ₁	l ₂	l ₃	l ₄	l ₅	w ₁	Axial load kgf max.	Compression max.
61480.W0001	Type 1	M12	115	13	45	85	50	37	15	60	120	8
61480.W0002	Type 1	M12	165	13	45	135	100	37	15	60	250	8
61480.W0003	Type 1	M12	215	13	45	185	150	37	15	60	350	8
61480.W0004	Type 1	M12	265	13	45	235	200	37	15	60	500	8
61480.W0005	Type 2	-	165	13	45	135	100	-	15	130	500	8
61480.W0006	Type 2	-	215	13	45	185	150	-	15	130	700	8
61480.W0007	Type 2	-	265	13	45	235	200	-	15	130	1000	8



61500

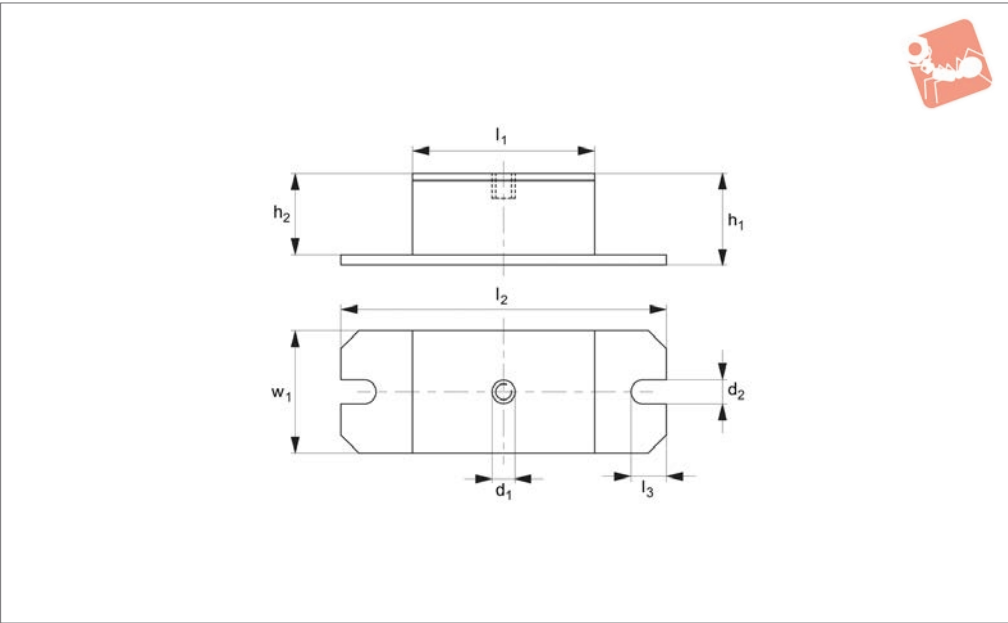

ANTI-VIBRATION

Material

Rubber on silver zincplated steel.

Tips

Particularly useful for fans, generators, motors etc.

Order No.	Shore hardness	d ₁	l ₁	d ₂	h ₁	h ₂	l ₂	l ₃	w ₁	Load kgf max.
61500.W0070	70 A	M12	100	13	50	45	180	25	70	1000
61500.W0055	55 A	M12	100	13	50	45	180	25	70	500
61500.W0080	80 A	M12	100	13	50	45	180	25	70	1200



Anti-vibration Bushes

metal-rubber

Anti-Vibration

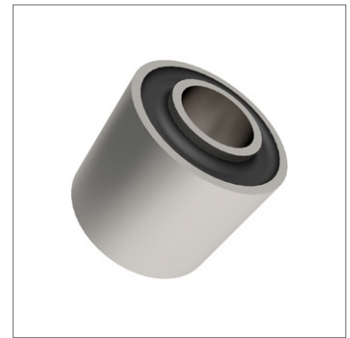

61700

ANTI-VIBRATION

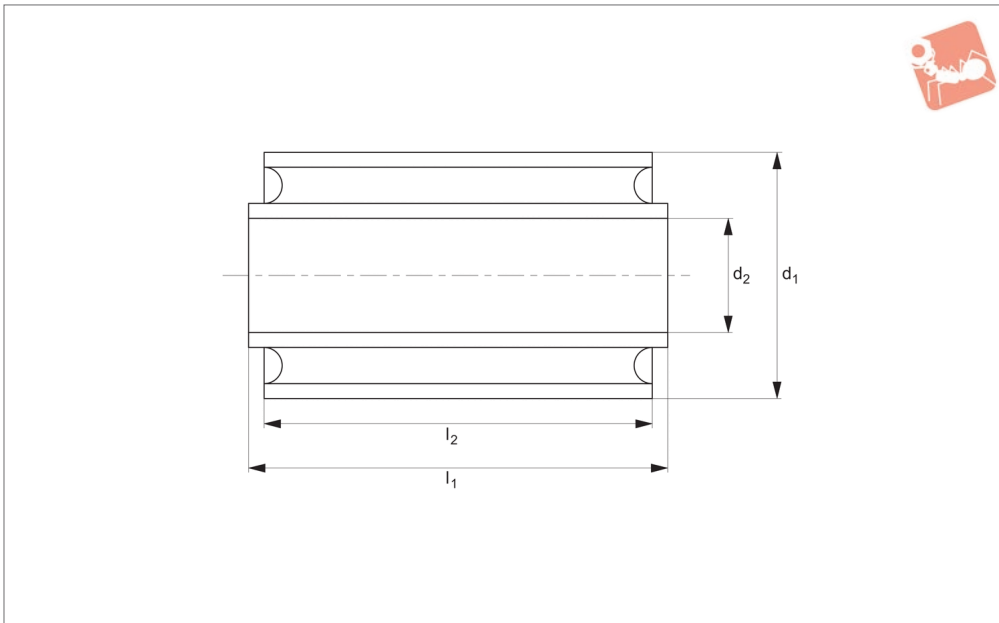

Material

Rubber on steel.

noise. The internal bush can move axially, radially, torsionally and pendular.

when putting into place.

Technical Notes

Useful to isolate vibration and reduce

Tips

Install by only pushing on external ring

Order No.	d ₁	d ₂	l ₁	l ₂	Radial compression mm	Axial load kgf max.	Radial load kgf max.	Axial compression mm
61700.W0081	16	8	15	15	0.2	15	30	0.8
61700.W0091	20.5	9.5	15	13	0.2	15	35	1.0
61700.W0101	21	10	26	24	0.4	25	70	1.5
61700.W0102	27	10	20	20	0.2	25	80	1.0
61700.W0111	24	11	18	16	0.3	24	90	0.8
61700.W0121	26	12	24	20	0.5	27	70	1.7
61700.W0123	50	12	50	45	1.1	60	200	2.1
61700.W0124	54	12.8	44.5	40	1.0	50	180	2.0
61700.W0141	27	14	54	48	0.4	95	330	1.5
61700.W0142	30	14	28	25	0.3	40	120	2.0
61700.W0144	31	14	35	33	0.3	70	170	2.0
61700.W0145	30	14.5	42	38	0.2	48	150	1.8
61700.W0146	50	14.5	24	20	0.9	45	70	2.0
61700.W0161	44	16	32	28	0.7	47	88	1.6
61700.W0163	54	16	28	22	1.5	40	80	3.4
61700.W0181	35	18	40	40	0.3	80	190	2.0
61700.W0182	43.5	18	42	35	0.8	85	200	3.8
61700.W0201	40	20	46	40	0.4	80	250	1.2
61700.W0202	41	20	20.5	20.5	0.4	40	100	1.0
61700.W0221	40	22	45	40	0.5	115	850	2.2
61700.W0222	63	22	72	65	0.6	265	670	4.0
61700.W0241	42	24	55	50	0.5	150	550	1.8
61700.W0242	50	24	71	65	0.7	220	750	2.4
61700.W0251	45	25	50	50	0.5	150	550	1.8
61700.W0253	65	25	55	45	0.6	180	450	3.8
61700.W0254	83	25	100	90	2.0	130	400	5.0
61700.W0281	48	28	36	34	0.7	100	210	2.5
61700.W0283	65	28	70	65	1.7	280	600	4.8
61700.W0284	75	28	135	125	0.5	480	1600	2.3
61700.W0381	64	38	76	70	0.4	380	860	2.6
61700.W0401	75	40	70	57	0.6	350	600	2.8
61700.W0421	78	42	86	80	0.5	350	1100	2.4
61700.W0481	93	48	80	76	0.6	800	1500	5.3



Order No.	d ₁	d ₂	l ₁	l ₂	Radial compression mm	Axial load kgf max.	Radial load kgf max.	Axial compression mm
61700.W0501	90	50	100	86	0.5	800	1500	5.1
61700.W0581	85	58	142	90	0.5	350	1800	1.6
61700.W0601	110	60	182	170	0.6	800	3000	1.8
61700.W0701	120	70	115	110	1.0	800	3500	3.5
61700.W0801	140	80	180	170	0.5	1500	7500	2.5
61700.W0901	145	100	120	110	0.4	850	2700	2.2

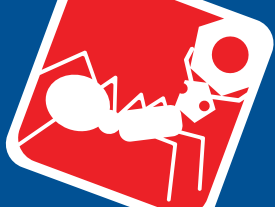

Anti-vibration Bushes

metal-rubber

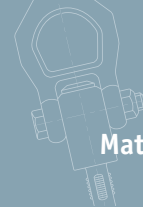

61700
Materials Handling

Range of movement

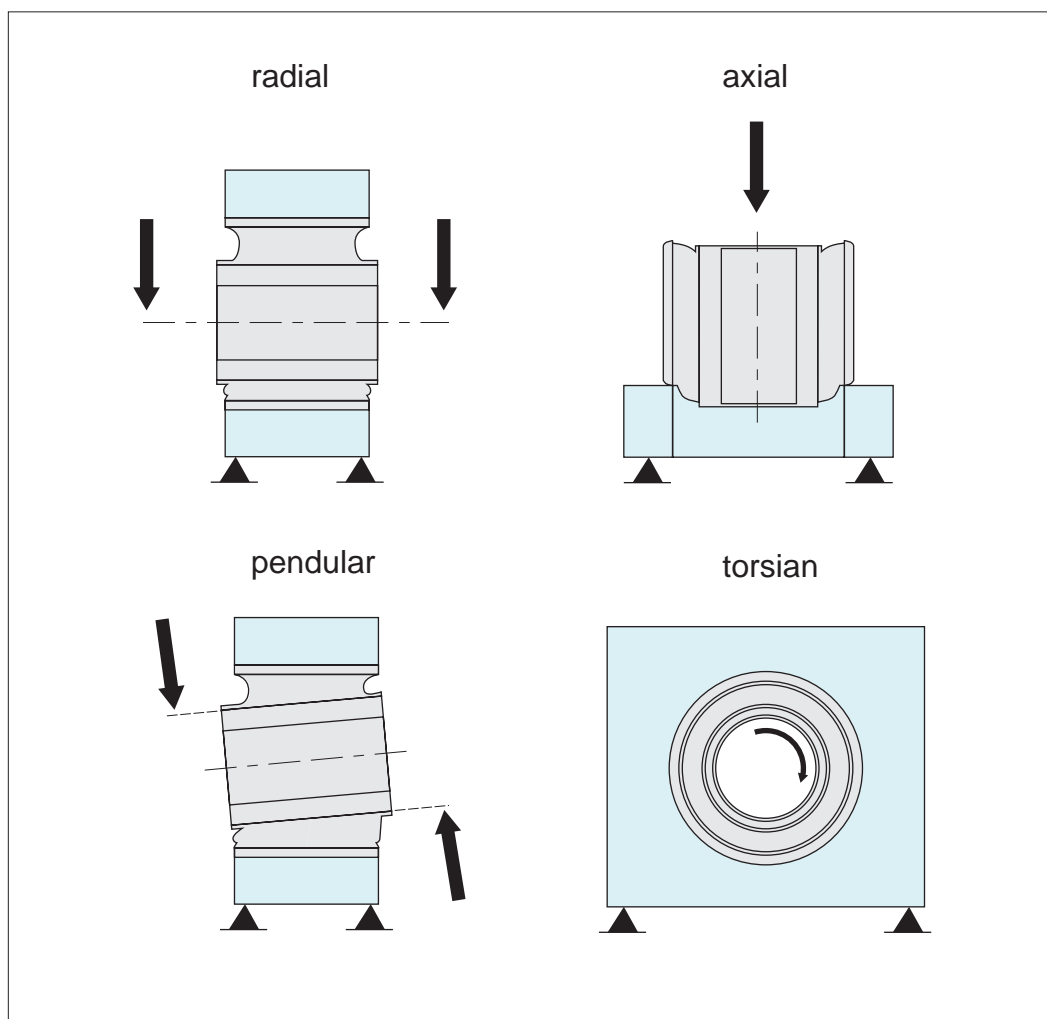

ANTI-VIBRATION

Inside diameter (d ₂)	Tolerances	Inside diameter (d ₁)	Tolerances
From 8mm to 15mm	-0 / + 0,15	From 16mm to 30mm	-0 / + 0,10
From 16mm to 25mm	-0 / + 0,30	From 31mm to 70mm	-0 / + 0,15
From 26mm to 50mm	-0 / + 0,30	From 71mm to 100mm	-0 / + 0,10

ov-W61700-A-T-anti-vibration-bushes-metal-rubber-rmh-Updated-28-10-2022



61820

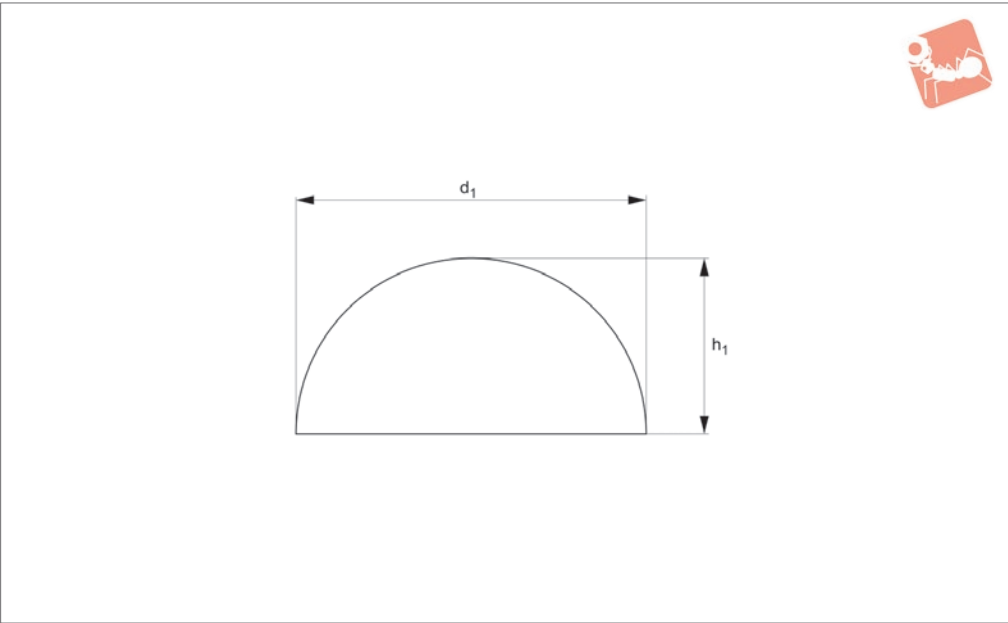

ANTI-VIBRATION

Material
Sorbothane.

Technical Notes
Sorbothane hemisphere mounts provide a

quick, cost effective method of isolating bench equipment and small machinery. Simply place the hemisphere under the unit to be isolated with the curved surface

up. Expect a 25-30% deflection when statically loaded.

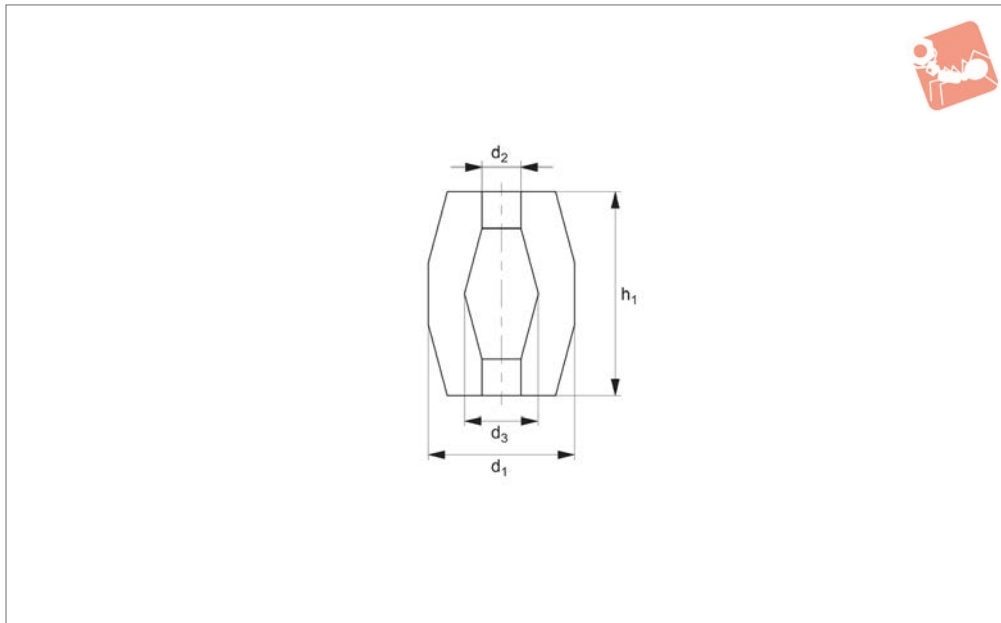

61830

ANTI-VIBRATION

Material

Rubber (hardness - 55 Shore A).

Technical Notes

Used in a wide range of vibrating

machines.

Allows high deformation with excellent spring back characteristics.

Supports axial and radial loads but not

designed for traction or tension loads. For radial loads please contact our Technical Department.

Order No.	d_1	h_1	d_2	d_3	Compression max.	Axial load kgf max.
61830.W0001	95	88	23	30	28	200
61830.W0002	100	110	20	30	36	500
61830.W0004	150	90	35	35	24	2000
61830.W0006	188	180	41	41	80	3500
61830.W0005	155	150	30	25	64	2500
61830.W0003	144	122	40	23	48	1000

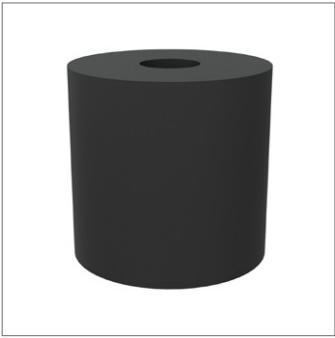

61850

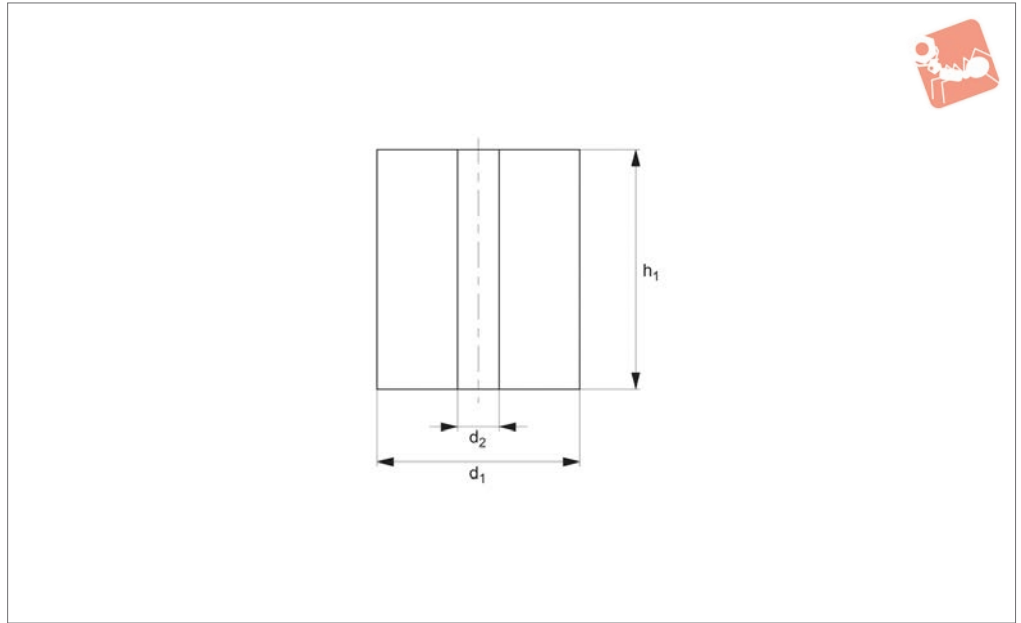

Material

Rubber (hardness - Shore 55 A).

Technical Notes

Used in a wide range of vibrating

machines.

Allows high deformation with excellent spring back characteristics.

Supports axial and radial loads but not

designed for traction or tension loads. For radial loads please contact our technical team.

Order No.	d ₁	h ₁	d ₂
61850.W0020	20	15	6
61850.W0030	30	20	8
61850.W0031	30	22	8
61850.W0035	35	30	12
61850.W0036	35	40	12
61850.W0040	40	30	10
61850.W0045	45	35	10
61850.W0046	45	45	10
61850.W0050	50	45	10
61850.W0060	60	40	12
61850.W0070	70	45	14
61850.W0080	80	50	16
61850.W0081	80	80	20
61850.W0093	93	120	20
61850.W0100	100	60	20
61850.W0102	100	147	20
61850.W0110	110	70	22
61850.W0130	130	60	25
61850.W0148	148	190	50
61850.W0160	160	100	30
61850.W0170	170	110	31
61850.W0200	200	125	70
61850.W0250	250	300	60



Anti-vibration Bushes

rubber, two-piece

Anti-Vibration

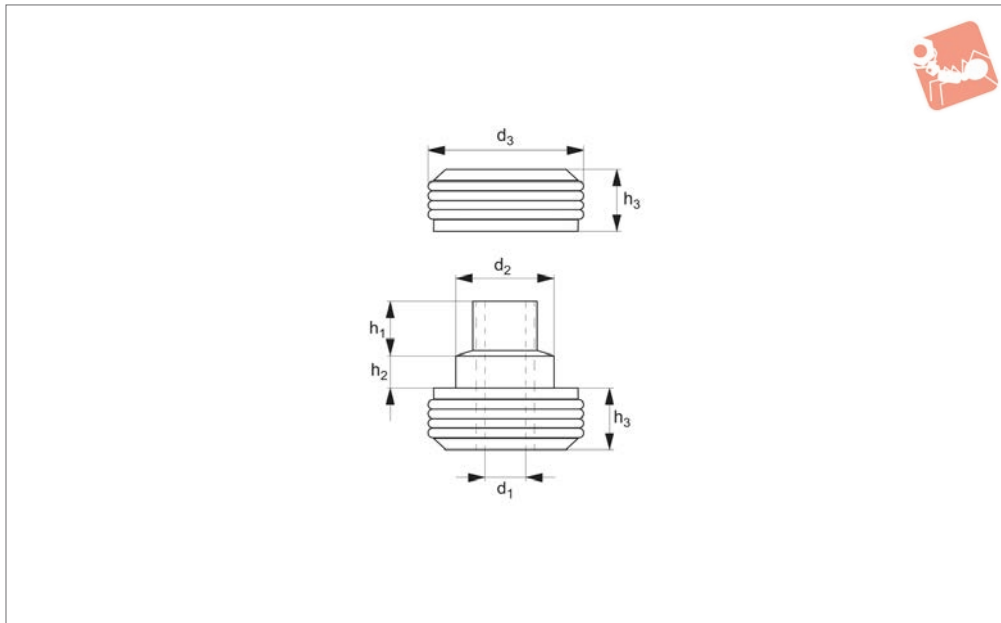

61855

ANTI-VIBRATION

Material

Rubber on silver zinc plated steel

Technical Notes

This anti-vibration mount is ideal for applications of major dynamic loads where

movement control is necessary, such as in the cabin of all types of mobile vehicles. It also offers optimal stability, as well as good attenuation of impacts and vibrations.

Important Notes

The double washer mounts are made of two parts of rubber, one of which bears an inside metal bushing which acts as a guide through the machine anchoring screw.

Order No.	d ₁	h ₁	d ₂	d ₃	h ₂	h ₃	Load kgf	Plate min.	Plate max.	Weight g
61855.W0500	13.5	18.5	31.5	49	11	20	80	12.5	14	153
61855.W0501	13.5	18.5	31.5	49	11	20	130	12.5	14	153
61855.W0650	17.0	24.0	39.5	64	15	23	120	19.0	22	350
61855.W0651	17.0	24	39.5	64	15	23	260	19.0	22	350
61855.W0900	23.0	31.0	58.0	88	17	25	260	25.0	29	675
61855.W0901	23.0	31.0	58.0	88	17	25	450	25.0	29	675

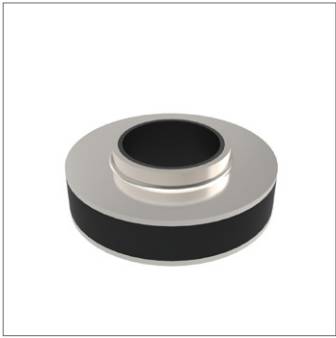

61640

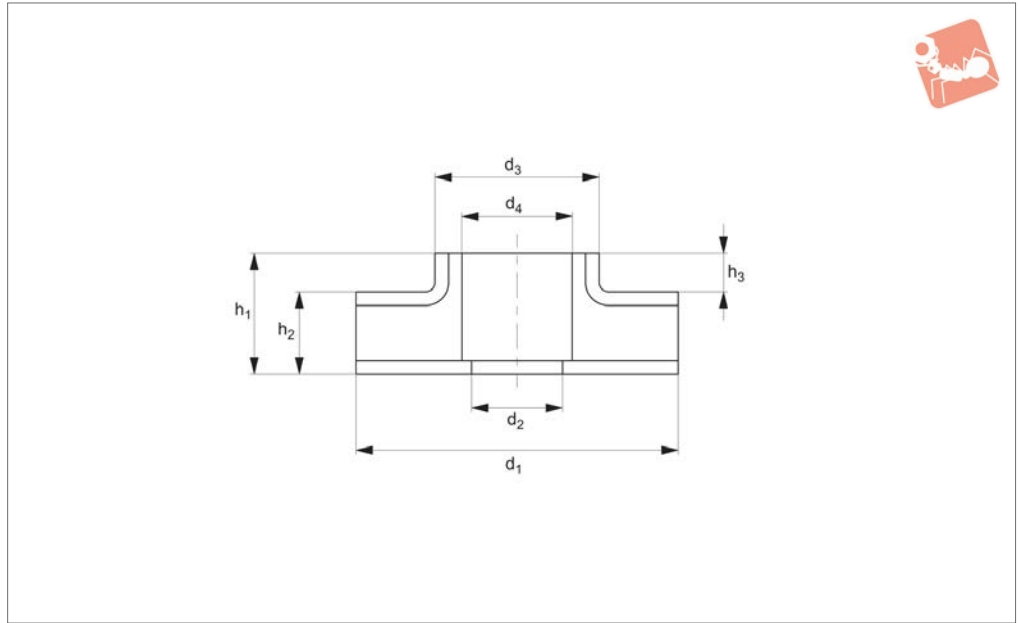

ANTI-VIBRATION

Material

Rubber on silver zinc plated steel.

withstand under compression.

Used where axial and radial loads are present. For frequencies higher than 20Hz.

Technical Notes

Static load relates to the load the unit can

Order No.	d ₁	d ₂	d ₃	d ₄	h ₁	h ₂	h ₃	Static load N max.
61640.W0036	36	8.5	18	12	14	10	4	100
61640.W0032	36	16.5	20	16.5	11.5	8.5	3	120
61640.W0050	50	16.5	23	20	22	13.5	8.5	150
61640.W0051	50	28	34	28	18	10.5	7.5	100
61640.W0055	55	24	31	28	15	11.5	3.5	175
61640.W0060	60	20.5	27	24	22	13	9	240
61640.W0075	75	24.5	33	29.5	27	20	8	300

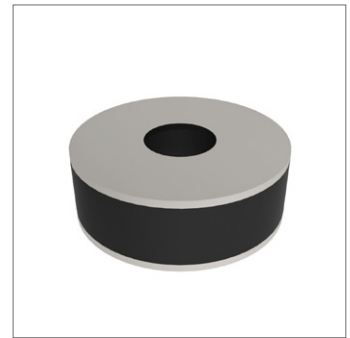
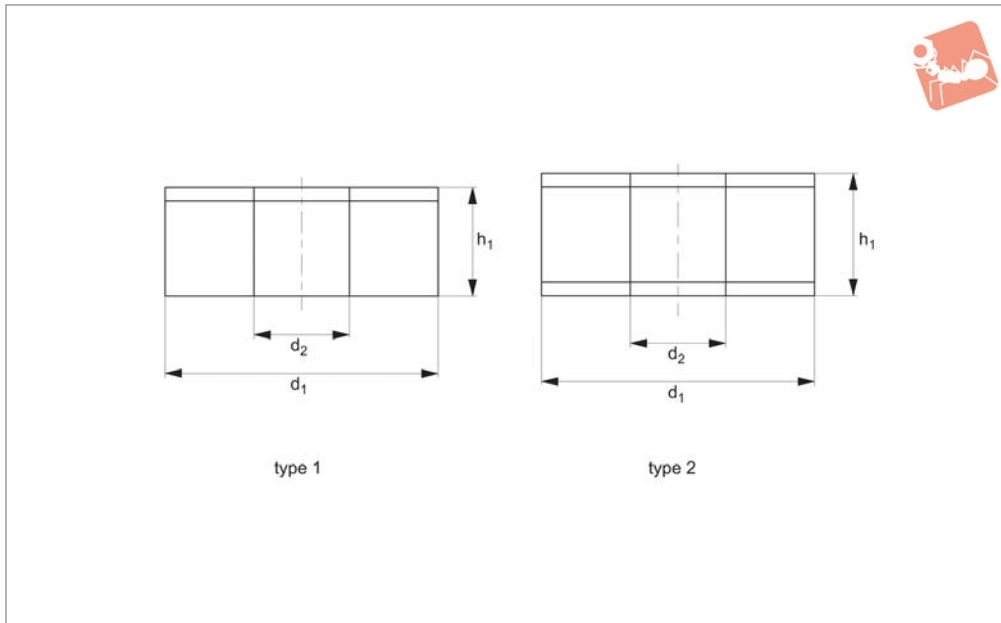

61650

ANTI-VIBRATION

Material

Rubber on silver zinc plated steel.

withstand under compression. Used where axial and radial loads are present.

Technical Notes

Static load relates to the load the unit can

For frequencies higher than 20Hz.

Order No.	Type	d ₁	d ₂	h ₁
61650.W0140	Type 1	40	12	20
61650.W0141	Type 1	40	14	15
61650.W0150	Type 1	50	16	20
61650.W0160	Type 1	60	22	30
61650.W0175	Type 1	75	25	25
61650.W0199	Type 1	100	32	60
61650.W0250	Type 2	50	15	30
61650.W0260	Type 2	60	20	30
61650.W0270	Type 2	70	20	30
61650.W0299	Type 2	100	41	35



61730

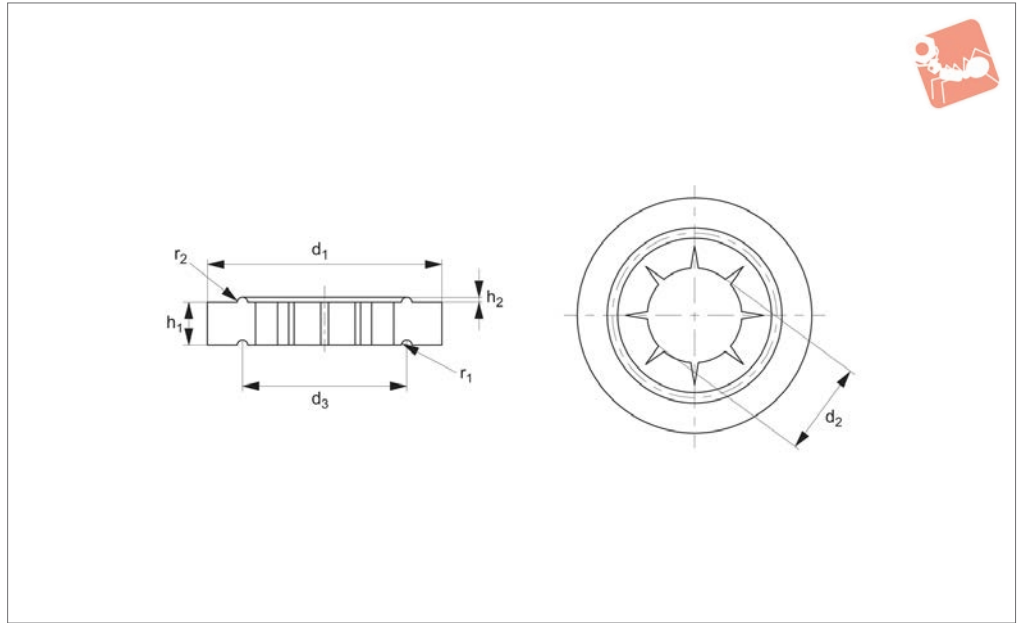

ANTI-VIBRATION

Material

Rubber on silver zinc plated steel (rubber hardness - 65 Shore A).

Order No.	d ₁	d ₂	d ₃	h ₁	h ₂	r ₁	r ₂	Compression max.	Axial load kgf max.
61730.W0001	162	66	114	30	2.5	4.5	2.5	5	2000
61730.W0002	170	95	125	23	2.5	5	2.5	4	2000
61730.W0003	210	88	164	24	2	4	2	4.5	6000

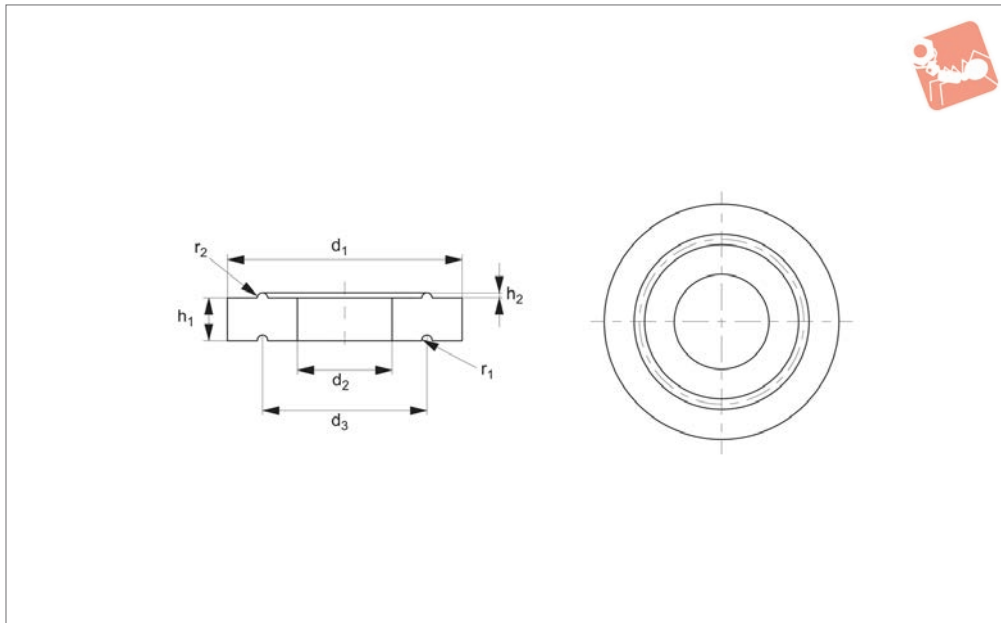

61760

ANTI-VIBRATION

Material

Rubber (hardness 70 Shore A).

Order No.	d ₁	d ₂	d ₃	h ₁	h ₂	r ₁	r ₂	Compression max.	Axial load kgf max.
61760.W0010	70	30	50	14	2	7	4	2	200
61760.W0020	72	32	52	23	2	2	2	7	400
61760.W0021	72	32	52	23	2	2	2	8.5	900
61760.W0022	76	37	58	12.5	3.5	2.5	2.5	2	550
61760.W0023	114	66	90	15	3	3	3	3.2	500
61760.W0024	114	66	90	15	3	3	3	5	1500
61760.W0030	116	52	84	23.5	2.5	3.5	2.5	3.5	800
61760.W0031	116	52	84	23.5	2.5	3.5	2.5	3.5	1000
61760.W0040	120	50	85	27.5	2.5	2.5	2.5	3.5	1000
61760.W0050	174	126	150	15	3	3	3	2	2000
61760.W0065	192	55	122	31	3	4	3	3.1	4340
61760.W0070	207	108	160	28	2	4	4	2.5	3000



61930

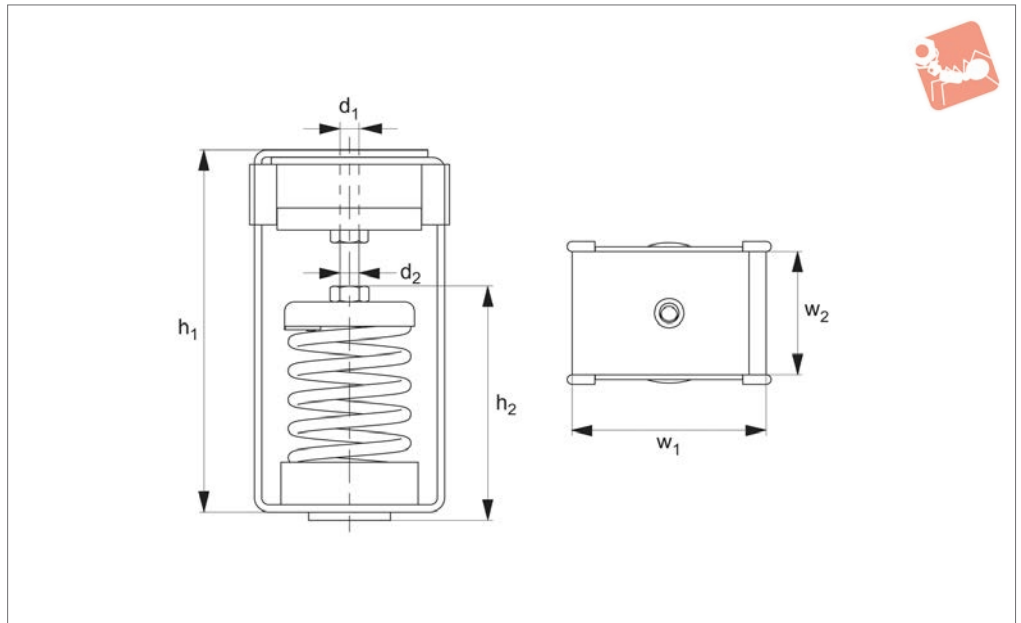

Material

Zinc plated steel (anti-corrosive treatment) with Sylomer® pad and steel spring.

Technical Notes

These hangers come in six different steel

spring strengths for increasing loads.

The metal housing has an anti-corrosive treatment, which can with stand very harsh conditions and also resist high tensile stresses up to 1000kg.

Order No.	d ₁	w ₁	h ₁	d ₂	h ₂	w ₂	Compression max.	Load kgf max.
61930.W0025	12	79	150	M8	94	50	18	25
61930.W0050	12	79	150	M8	94	50	18	50
61930.W0075	12	79	150	M8	94	50	18	75
61930.W0100	12	79	150	M8	94	50	18	100
61930.W0125	12	79	150	M8	94	50	20	125
61930.W0150	12	79	150	M8	94	50	20	150



Acoustic Suspension Hanger spring spring

Anti-Vibration

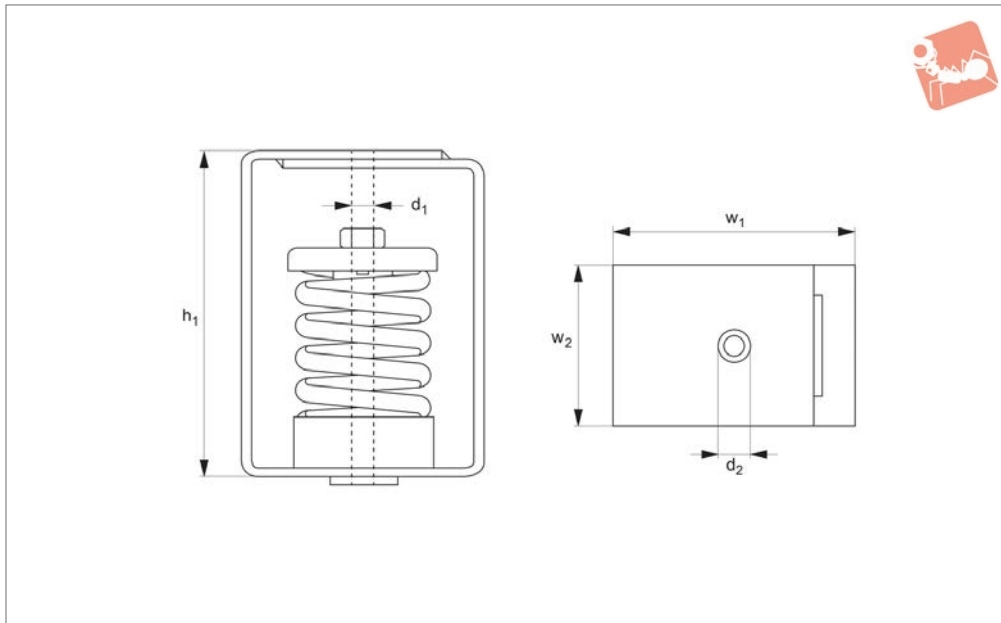

61931

ANTI-VIBRATION

Material

Zinc plated steel (anti-corrosive treatment).

where objects are suspended from ceilings. The spring in the body provides good anti-vibration properties.

load to be carried per unit.

These hanger can be used for fans, distribution pipes, ducts and acoustic ceilings.

Technical Notes

These units are designed for installations

Tips

Select the damper corresponding to the

Order No.	d ₁	w ₁	h ₁	d ₂	w ₂	h ₁	Load kgf max.
61931.W0025	M 8	75	120	12	50	25	25
61931.W0050	M 8	75	120	12	50	50	50
61931.W0075	M 8	75	120	12	50	75	75
61931.W0100	M 8	75	120	12	50	100	100
61931.W0125	M 8	75	120	12	50	125	125
61931.W0150	M12	120	160	16	80	150	150
61931.W0200	M12	120	160	16	80	200	200
61931.W0250	M12	120	160	16	80	250	250
61931.W0350	M12	120	160	16	80	350	350
61931.W0500	M14	140	180	18	100	500	500
61931.W0750	M14	140	180	18	100	750	750



61932

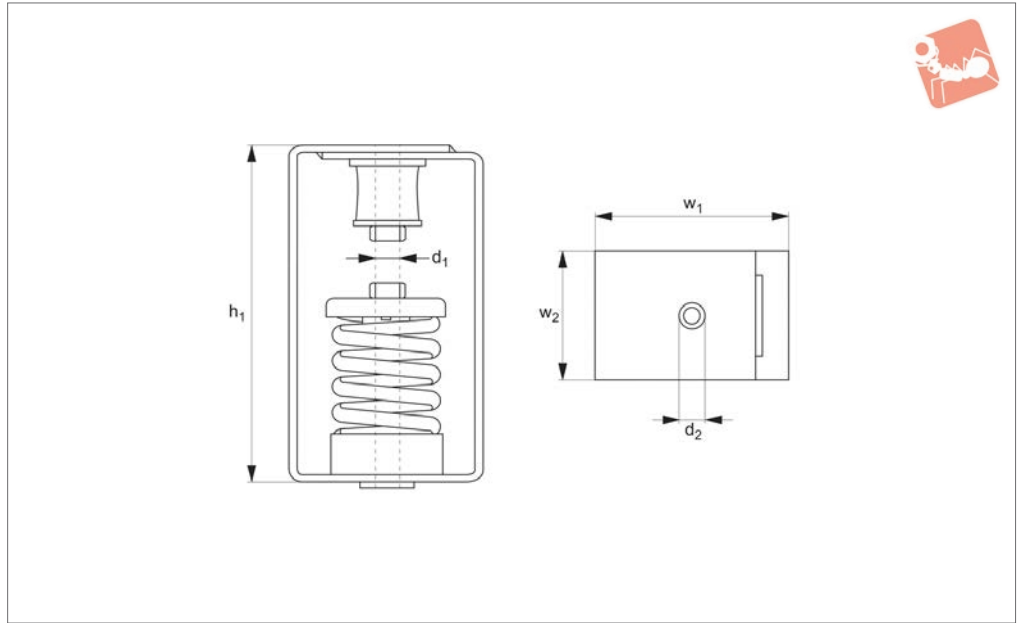

ANTI-VIBRATION

Material

Zinc plated steel and rubber.

The spring in the body provides good anti-vibration properties.

These hanger can be used for fans, distribution pipes, ducts and acoustic ceilings.

Technical Notes

These units are designed for installations where objects are suspended from ceilings.

Tips

Select the damper corresponding to the load to be carried per unit.

Order No.	d ₁	w ₁	h ₁	d ₂	w ₂	h ₁	Load kgf max.
61932.W0025	M8	75	150	12	50	150	25
61932.W0050	M8	75	150	12	50	150	50
61932.W0075	M8	75	150	12	50	150	75
61932.W0100	M8	75	150	12	50	150	100



Acoustic Suspension Hanger without nut

Anti-Vibration

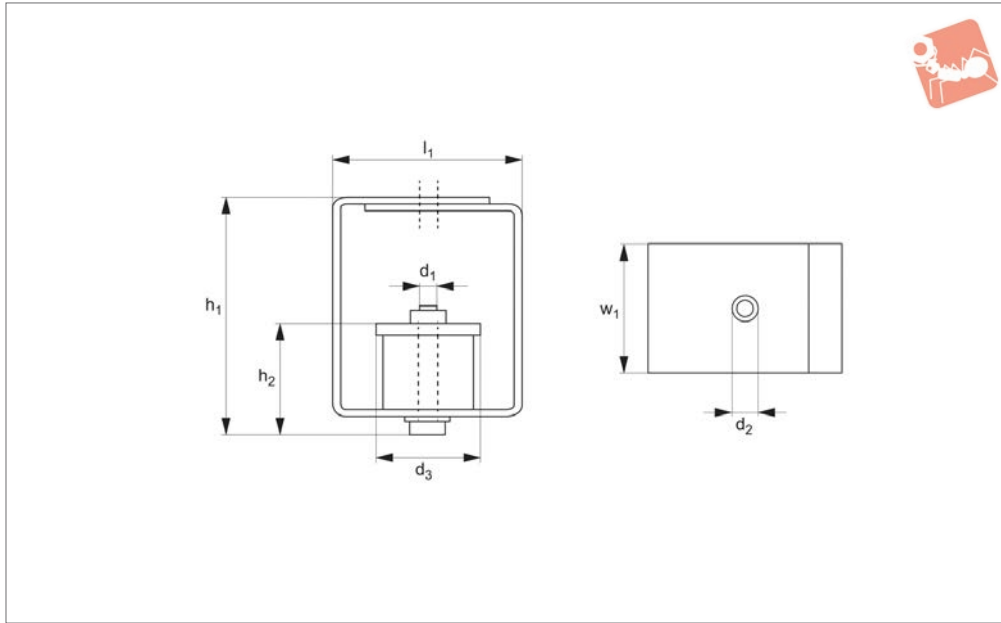

61933

ANTI-VIBRATION

Material

Steel anti-corrosive zinc plated, with rubber (50 shore A) cylinder.

where objects are suspended from ceilings. The spring in the body provides good anti-vibration properties.

load to be carried per unit. These hanger can be used for fans, distribution pipes, ducts and acoustic ceilings.

Technical Notes

These units are designed for installations

Tips

Select the damper corresponding to the

Order No.	d ₁	w ₁	h ₁	d ₂	d ₃	h ₂	l ₁	Load kgf max.
61933.W0030	M6	40	47	8	30	30	40	30
61933.W0060	M6	40	47	8	30	30	40	60



61934

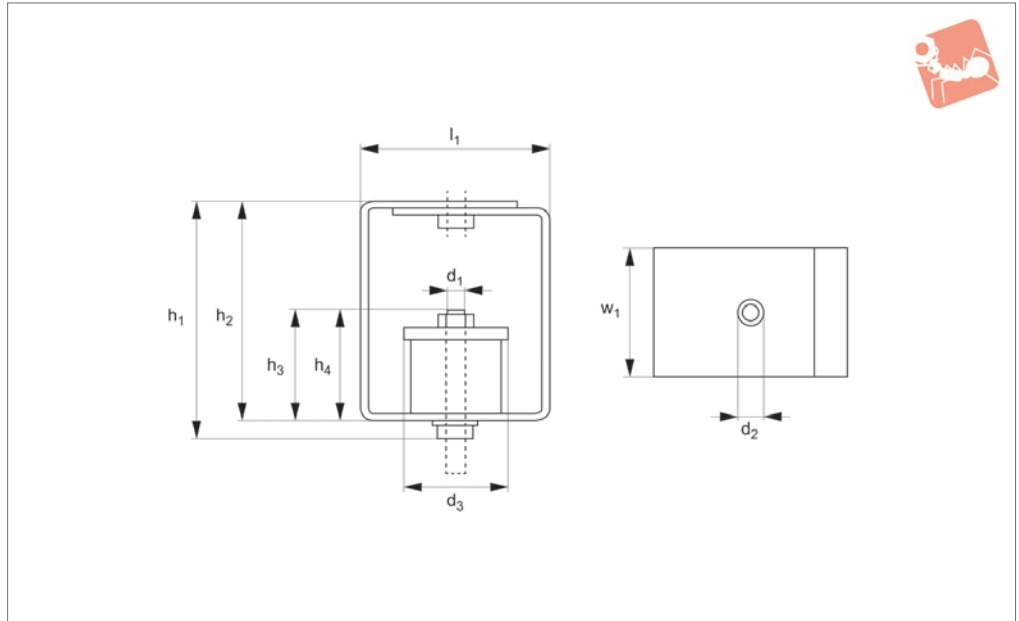

Material

Steel anti-corrosive zinc plated, with rubber (50 shore A) cylinder.

Technical Notes

These units are designed for installations

where objects are suspended from ceilings. The spring in the body provides good anti-vibration properties. The metal hanger is designed to cope with loads up to 1000kg.

Tips

Select the damper corresponding to the load to be carried per unit. These hanger can be used for fans, distribution pipes, ducts and acoustic ceilings.

Order No.	d ₁	w ₁	h ₁	d ₂	d ₃	d ₄	h ₂	h ₃	h ₄	l ₁	Load range kgf
61934.W0030	M 6	40	55.03	M 6	30	18	46.3	38	30	40	8-30
61934.W0060	M 6	40	55.03	M 6	30	18	46.3	38	30	40	25-60
61934.W0100	M 8	55	76.40	M 8	40	16	68.0	43	34	55	40-100
61934.W0150	M 8	55	76.40	M 8	40	16	68.0	43	34	55	80-150

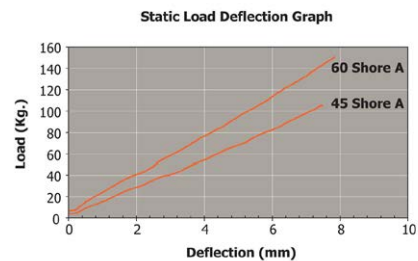



Acoustic Wall Damper right angle right angle fixing

Anti-Vibration

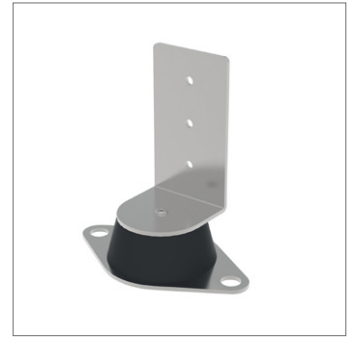

61936

ANTI-VIBRATION

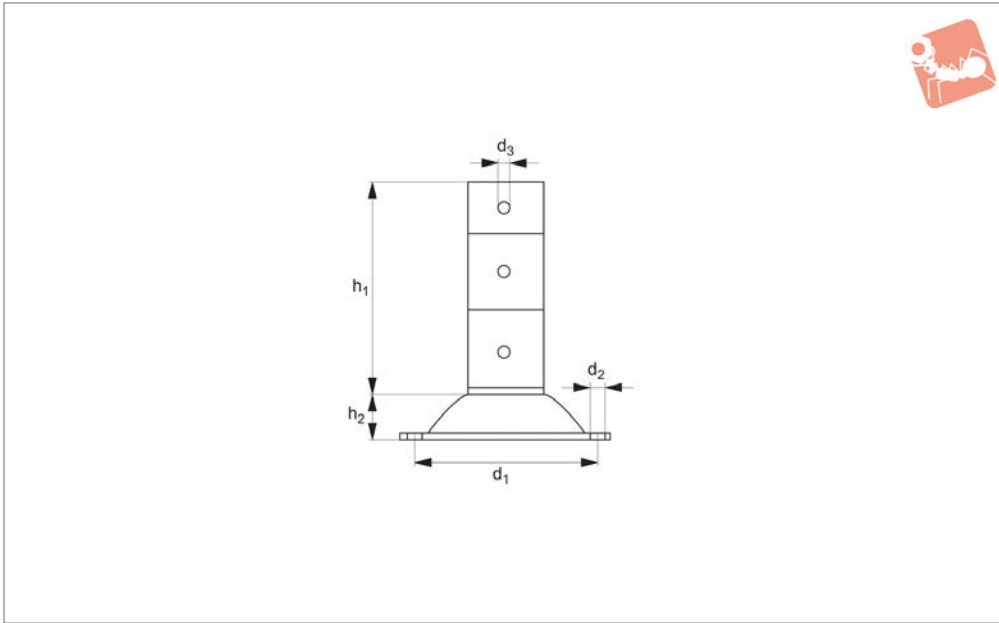

Material

Rubber on steel (zinc plated).

Technical Notes

These units are designed for installations where objects are suspended from the

ceiling or the wall. The spring in the body provides good anti-vibration properties.

Tips

Select the damper corresponding to the load to be carried per unit.

These hanger can be used for fans, distribution pipes, ducts and acoustic ceilings/walls.

Order No.	d ₁	h ₁	d ₂	d ₃	h ₂	Load kgf max.
61936.W0076	76	72	6.5	4	24	10

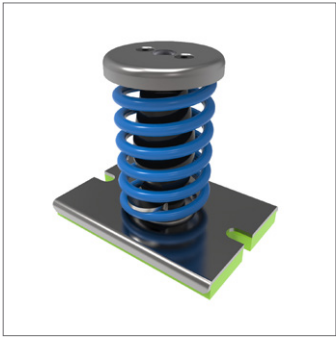

61922

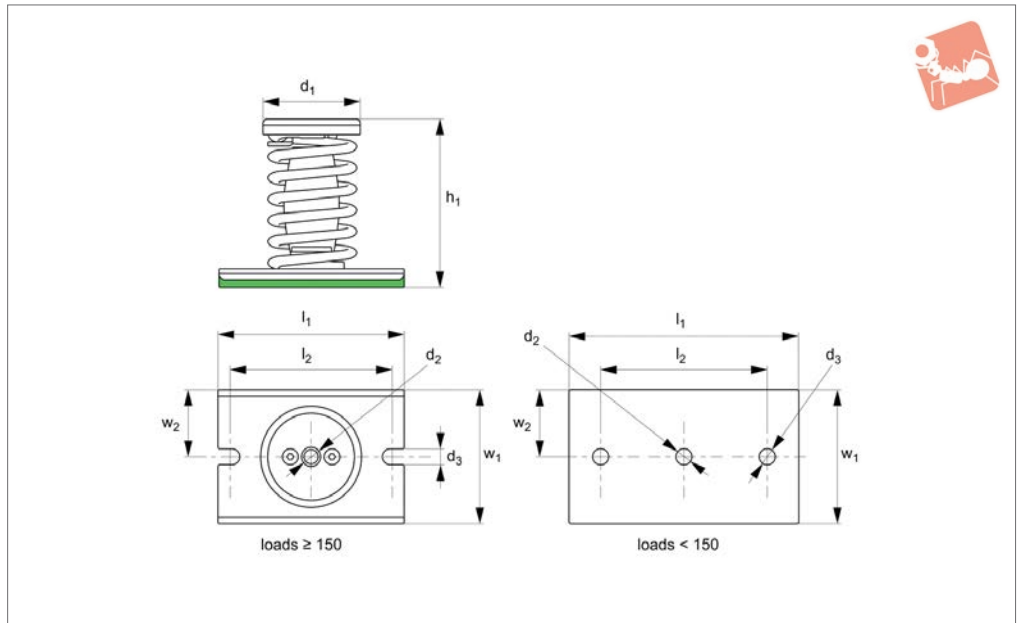

ANTI-VIBRATION

Material

High tensile steel with sylomer anti-slide base.

Technical Notes

The sylomer mat that these dampers incor-

porate, isolates the mid-high frequency vibrations which are transmitted through the coils of the metal springs.

Tips

These are used in sectors such as air

compressors, pump and pumping equipment and acoustic isolation of premises.

Order No.	Spring colour	l_1	h_1	d_1	w_1	d_2	d_3	l_2	w_2	Compression max.	Load kgf max.	Weight kg
61922.W0080	Black	100	78	54	69.5	M 8	8.5	80	34.75	20	25	0.29
61922.W0081	Blue	100	78	54	69.5	M 8	8.5	80	34.75	20	50	0.27
61922.W0082	Grey	100	78	54	69.5	M 8	8.5	80	34.75	20	75	0.30
61922.W0083	Beige	100	78	54	69.5	M 8	8.5	80	34.75	20	100	0.35
61922.W0084	White	100	78	54	69.5	M 8	8.5	80	34.75	20	125	0.395
61922.W0120	Blue	140	127	75	98.5	M12	12	120	49.25	30	150	1.10
61922.W0121	White	140	127	75	98.5	M12	12	120	49.25	30	200	1.14
61922.W0122	Black	140	127	75	98.5	M12	12	120	49.25	30	250	1.23
61922.W0123	Cream	140	127	75	98.5	M12	12	120	49.25	30	350	1.39
61922.W0140	Light Grey	140	127	93	98.5	M14	12	120	49.25	18	500	2.56
61922.W0141	Green	140	127	93	98.5	M14	12	120	49.25	18	750	3.04



Spring Vibration Damper two spring two spring

Anti-Vibration



61923

ANTI-VIBRATION

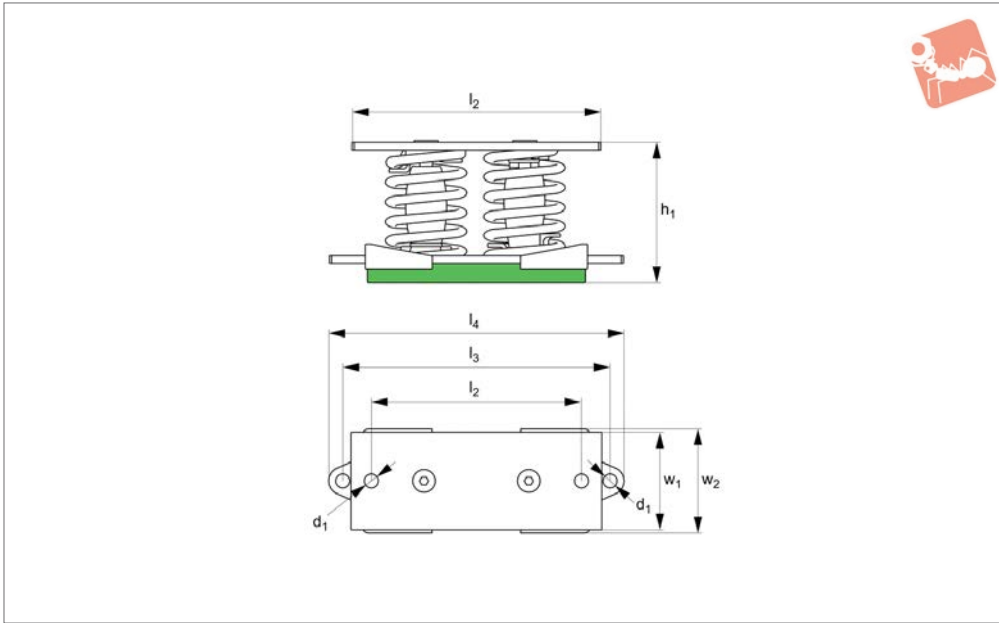

Material

High tensile steel with sylomer anti-slide base

porate, isolates the mid-high frequency vibrations which are transmitted through the coils of the metal springs.

compressors, pump and pumping equipment and acoustic isolation of premises.

Technical Notes

The sylomer mat that these dampers incor-

Tips

These are used in sectors such as air

Order No.	Spring colour	l_1	h	d	w_1	l_2	l_3	l_4	w_2	Compression max.	Load kgf max.	Weight kg
61923.W0120	Blue	200	136	12	75	170	220	244	81	30	300	3.10
61923.W0121	White	200	136	12	75	170	220	244	81	30	400	3.17
61923.W0122	Black	200	136	12	75	170	220	244	81	30	500	3.35
61923.W0123	Cream	200	136	12	75	170	220	244	81	30	700	3.70
61923.W0140	Light Grey	250	136	14	100	210	270	298	106	17	1000	5.90
61923.W0141	Green	250	136	14	100	210	270	298	106	17	1500	6.84



61924

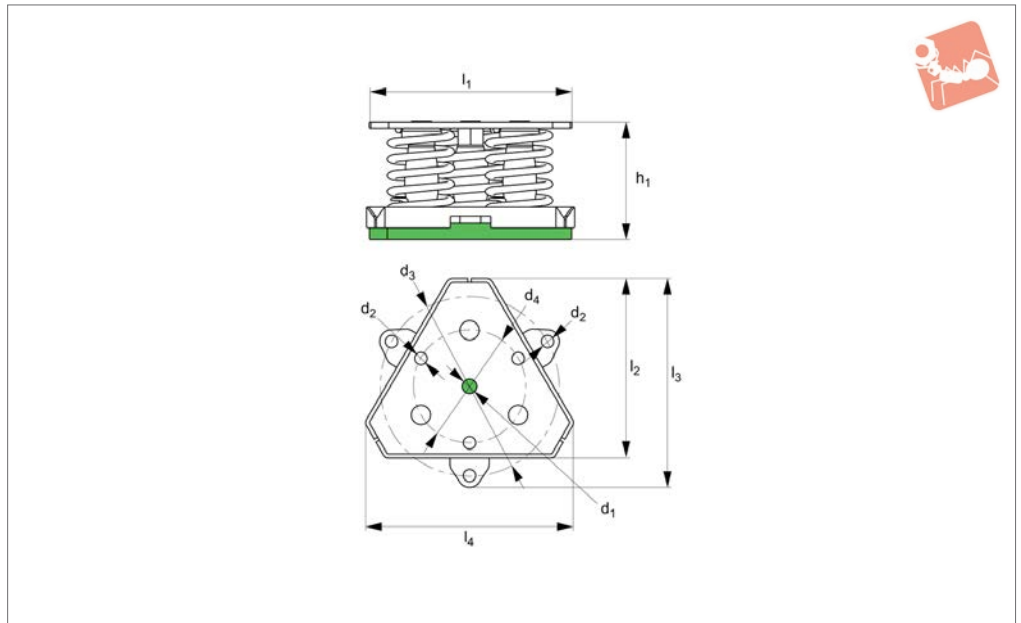

Material

High tensile steel with sylomer anti-slide base

porate, isolates the mid-high frequency vibrations which are transmitted through the coils of the metal springs.

compressors, pump and pumping equipment and acoustic isolation of premises.

Technical Notes

The sylomer mat that these dampers incor-

Tips

These are used in sectors such as air

Order No.	Spring colour	l_1	h	d_1	d_2	d_3	l_2	l_3	l_4	Compression max.	Load kgf max.	Weight kg
61924.W0160	Blue	196.3	136	M16	12	180	175	207.7	201.4	30	450	4.60
61924.W0161	White	196.3	136	M16	12	180	176	207.7	201.4	30	600	4.71
61924.W0162	Black	196.3	136	M16	12	180	176	207.7	201.4	30	750	4.98
61924.W0163	Cream	196.3	136	M16	12	180	176	207.7	201.4	30	1050	5.52
61924.W0200	Light Grey	246.0	136	M20	14	220	219	255.7	251.0	17	1500	8.56
61924.W0201	Green	246.0	136	M20	14	220	219	255.7	251.0	17	2250	9.96



Spring Vibration Damper four spring four spring

Anti-Vibration



61925

ANTI-VIBRATION

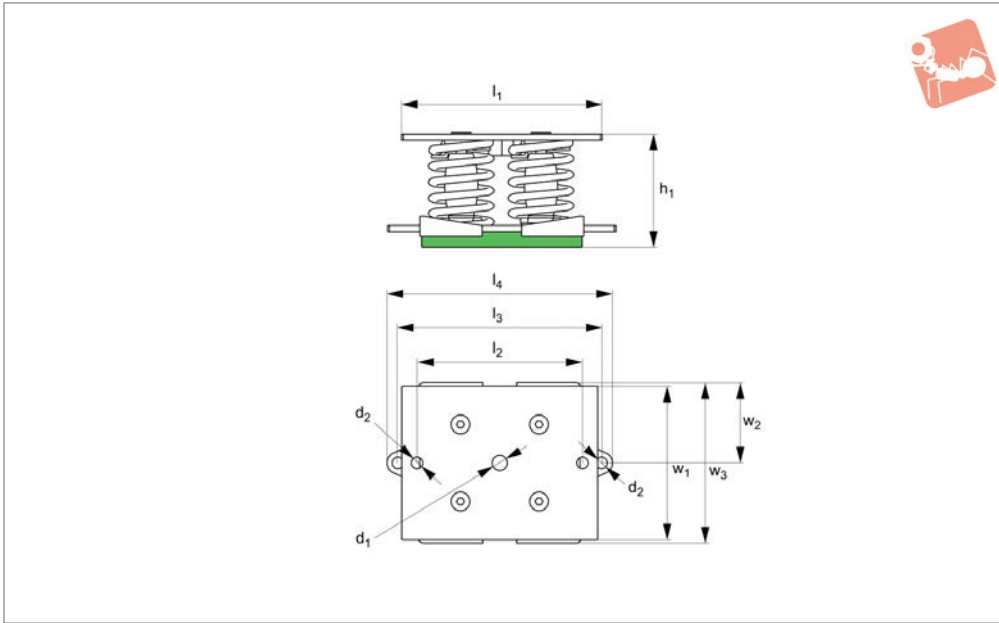

Material

High tensile steel with sylomer anti-slide base.

porate, isolates the mid-high frequency vibrations which are transmitted through the coils of the metal springs.

compressors, pump and pumping equipment and acoustic isolation of premises.

Technical Notes

The sylomer mat that these dampers incor-

Tips

These are used in sectors such as air

Order No.	Spring colour	l_1	h	d_1	w_1	d_2	l_2	l_3	l_4	w_2	w_3	Compression max.	Load kgf max.	Weight kg
61925.W0160	Blue	200	136	M16	150	12	170	190	214	75	156	30	600	6.41
61925.W0161	White	200	136	M16	150	12	170	190	214	75	156	30	800	6.57
61925.W0162	Black	200	136	M16	150	12	170	190	214	75	156	30	1000	6.70
61925.W0163	Cream	200	136	M16	150	12	170	190	214	75	156	30	1400	7.64
61925.W0200	Light Grey	250	136	M20	200	14	210	260	288	100	206	18	2000	12.10
61925.W0201	Green	250	136	M20	200	14	210	260	288	100	206	18	3000	13.96



61926

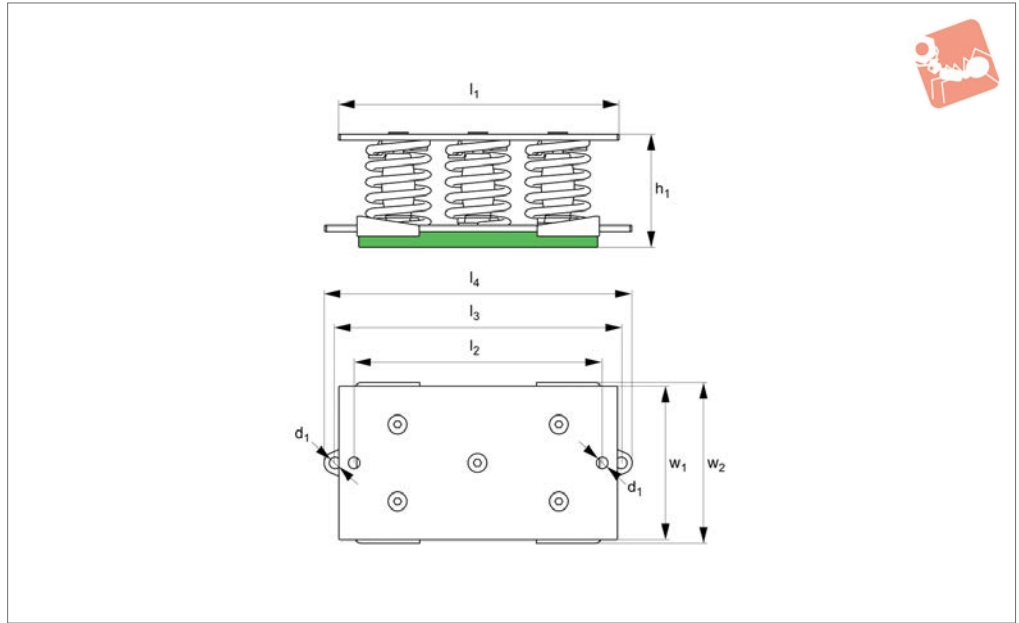

Material

High tensile steel with sylomer anti-slide base.

Technical Notes

The sylomer mat that these dampers incor-

porate, isolates the mid-high frequency vibrations which are transmitted through the coils of the metal springs.

Tips

These are used in sectors such as air

compressors, pump and pumping equipment and acoustic isolation of premises.

Order No.	Spring colour	l_1	h	d	w_1	l_2	l_3	l_4	w_2	Compression max.	Load kgf max.	Weight kg
61926.W0160	Blue	280	136	16	150	251	290	322	156	30	750	8.50
61926.W0161	White	280	136	16	150	251	290	322	156	30	1000	8.69
61926.W0162	Black	280	136	16	150	251	290	322	156	30	1250	9.16
61926.W0163	Cream	280	136	16	150	251	290	322	156	30	1750	10.03
61926.W0180	Light Grey	350	136	18	200	315	360	396	206	18	2500	15.71
61926.W0181	Green	350	136	18	200	315	360	396	206	18	3750	18.05



Spring Vibration Damper six spring six spring

Anti-Vibration

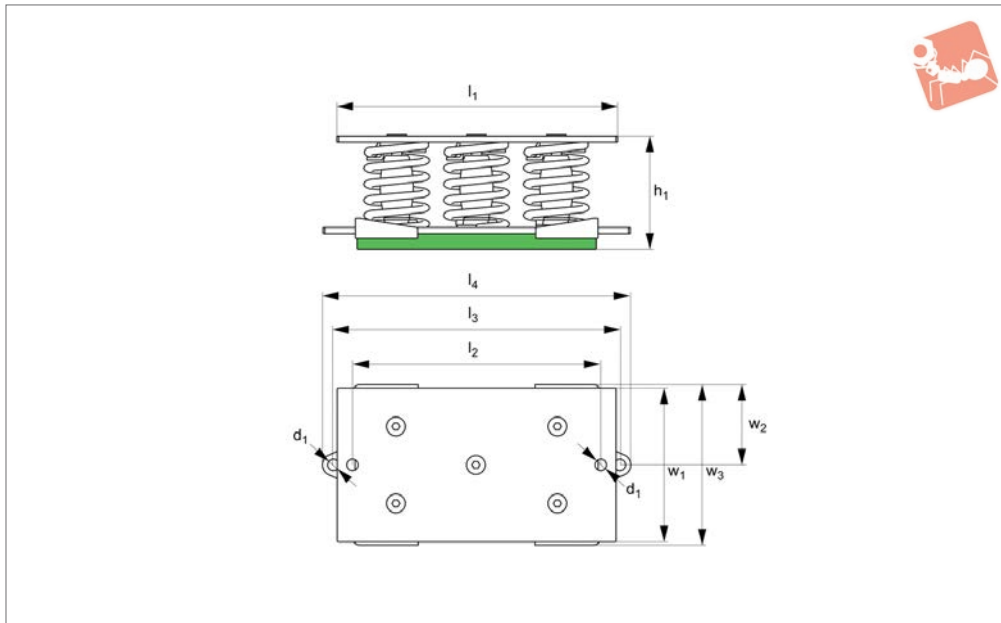

61927

ANTI-VIBRATION

Material

High tensile steel with sylomer anti-slide base.

porate, isolates the mid-high frequency vibrations which are transmitted through the coils of the metal springs.

compressors, pump and pumping equipment and acoustic isolation of premises.

Technical Notes

The sylomer mat that these dampers incor-

Tips

These are used in sectors such as air

Order No.	Spring colour	l_1	h	d	w_1	l_2	l_3	l_4	w_2	w_3	Compression max.	Load kgf max.	Weight kg
61927.W0160	Blue	280	136	16	150	248	290	322	75	156	30	900	8.93
61927.W0161	White	280	136	16	150	248	290	322	75	156	30	1200	9.16
61927.W0162	Black	280	136	16	150	248	290	322	75	156	30	1500	9.68
61927.W0163	Cream	280	136	16	150	248	290	322	75	156	30	2100	10.77
61927.W0180	Light Grey	350	136	18	200	300	360	396	100	206	18	3000	16.84
61927.W0181	Green	350	136	18	200	300	360	396	100	206	18	4500	19.65

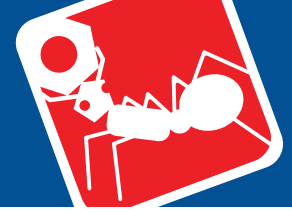

61928

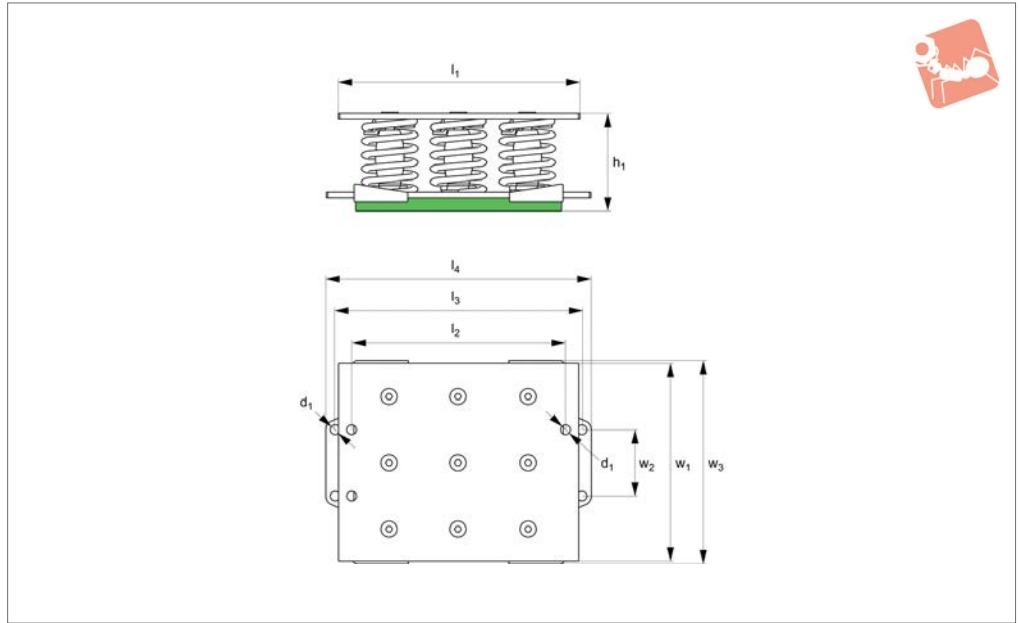

ANTI-VIBRATION

Material

High tensile steel with sylomer anti-slide base.

Technical Notes

The sylomer mat that these dampers incor-

porate, isolates the mid-high frequency vibrations which are transmitted through the coils of the metal springs.

Tips

These are used in sectors such as air

compressors, pump and pumping equipment and acoustic isolation of premises.

Order No.	Spring colour	l_1	h	d	w_1	l_2	l_3	l_4	w_2	w_3	Compression max.	Load kgf max.	Weight kg
61928.W0160	Blue	280	136	16	226	248	290	322	75	232	30	1350	13.70
61928.W0161	White	280	136	16	226	248	290	322	75	232	30	1800	14.04
61928.W0162	Black	280	136	16	226	248	290	322	75	232	30	2250	14.83
61928.W0163	Cream	280	136	16	226	248	290	322	75	232	30	3150	16.46
61928.W0180	Light Grey	350	136	18	300	310	360	396	150	306	18	4500	21.54
61928.W0181	Green	350	136	18	300	310	360	396	150	306	18	6750	31.75

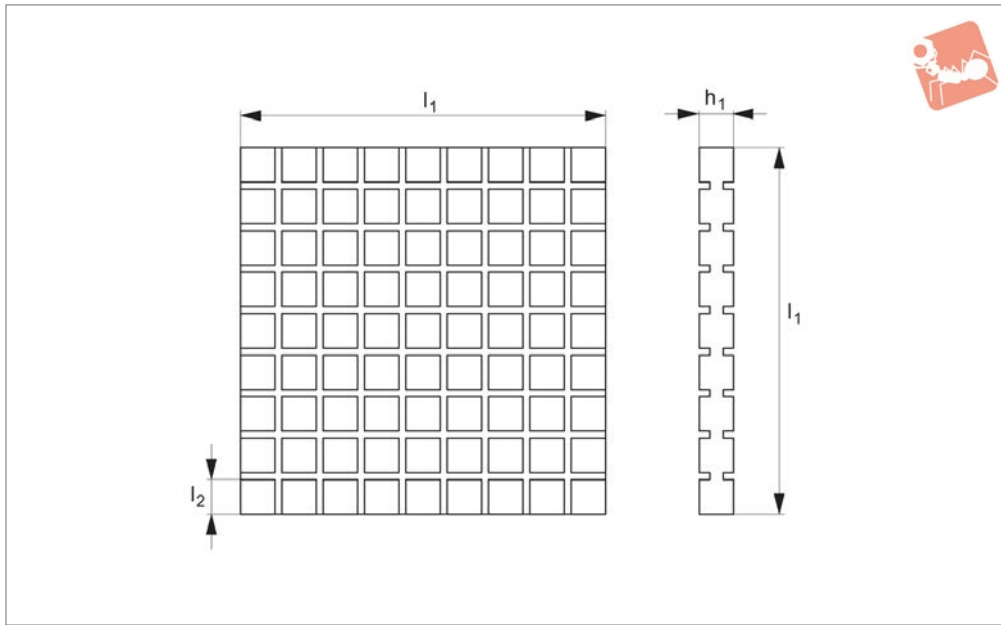

61780

ANTI-VIBRATION

Material

Rubber (hardness - 55 Shore A).

Technical Notes

The pad can be cut to suit the application

as required.

Differs from a plain rubber mat as the squared units can deform - improving its anti-vibration features.

Tips

High frequency isolation (30-40Hz).
Own frequency 18Hz.

Order No.	l_1	l_2	h_1	Compression max.	Load kgf/cm ² max.
61780.W0210	210	10	14	2	8
61780.W0302	300	10	5	1	8
61780.W0301	300	10	7	1.6	8
61780.W0500	500	10	7	1	8



61800

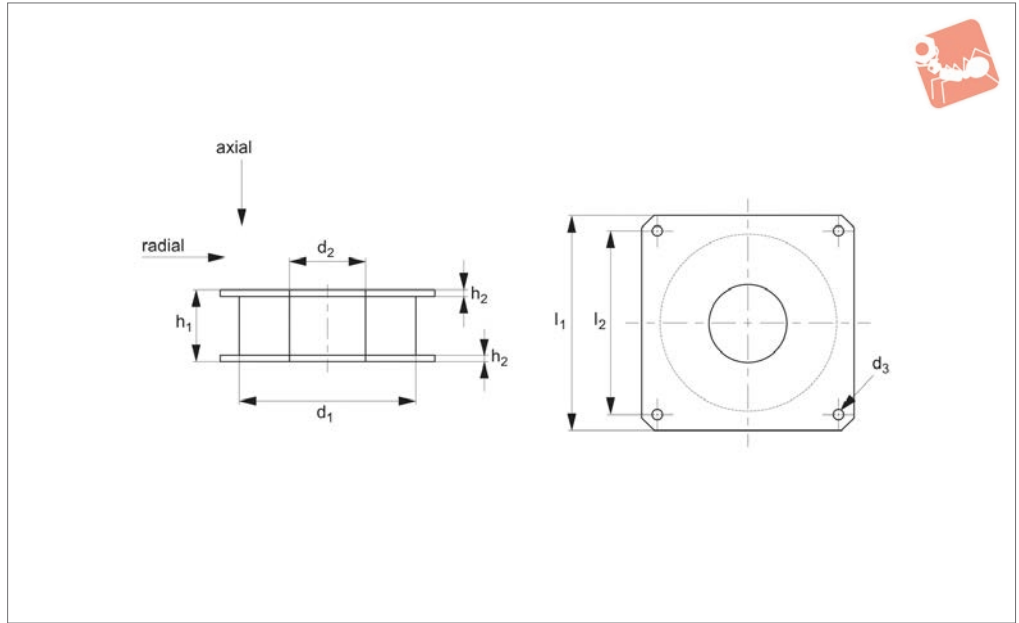

Material

Rubber on silver zinc plated steel (rubber hardness - 65 Shore A).

Order No.	l_1	d_1	d_2	d_3	l_2	h_1	h_2	Axial compression max.	Radial compression max.	Axial load kgf max.	Radial load kgf max.
61800.W0135	135	120	50	9	105	42	3	15	10	2500	300
61800.W0170	170	140	65	15	145	100	4	15	10	2500	300
61800.W0180	180	160	60	9	140	46	4	15	10	2500	300
61800.W0210	210	185	70	11	165	55	5	15	10	2500	300
61800.W0250	250	230	100	16	215	48	4	15	10	2500	300



Anti-vibration Impact Plates

metal-rubber

Anti-Vibration

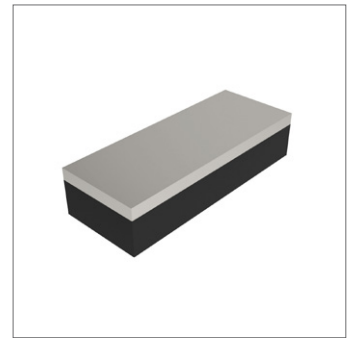
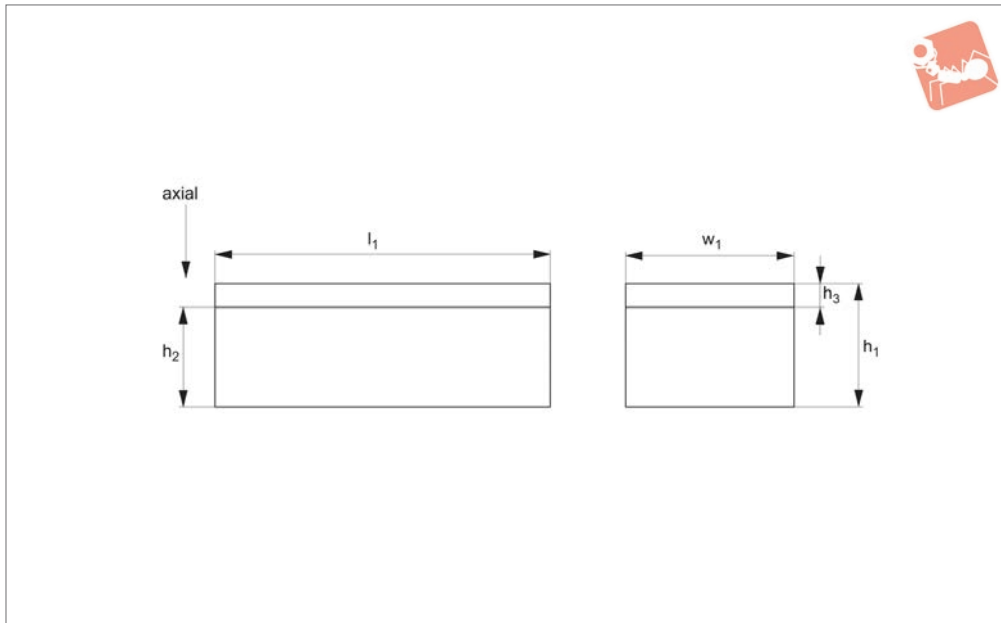

61600

ANTI-VIBRATION

Material

Rubber on silver zinc plated steel (rubber hardness - 60 Shore A).

be drilled to suit the number of threads, thread sizes and the pitch you require.

request.

Technical Notes

The metal plate is provided blank so it can

Part no. 61600.0500-125 has a ribbed base. Other sizes can be supplied on

Order No.	l_1	w_1	h_1	h_2	h_3	Axial load kgf max.	Compression max.
61600.W0035	1250	35	40	30	10	2500	2.0
61600.W0070	180	70	40	30	10	1000	2.8
61600.W0071	245	70	40	30	10	1300	3.7
61600.W0072	285	70	40	30	10	2000	3.6
61600.W0073	320	70	40	30	10	2700	3.5
61600.W0120	250	120	40	28	12	5000	3.3
61600.W0125	500	125	30	15	15	10000	4.0

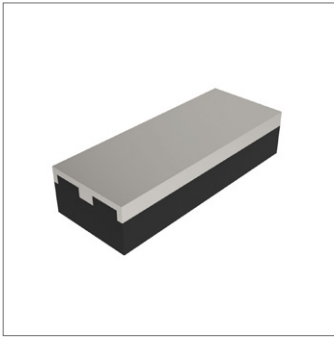

61610

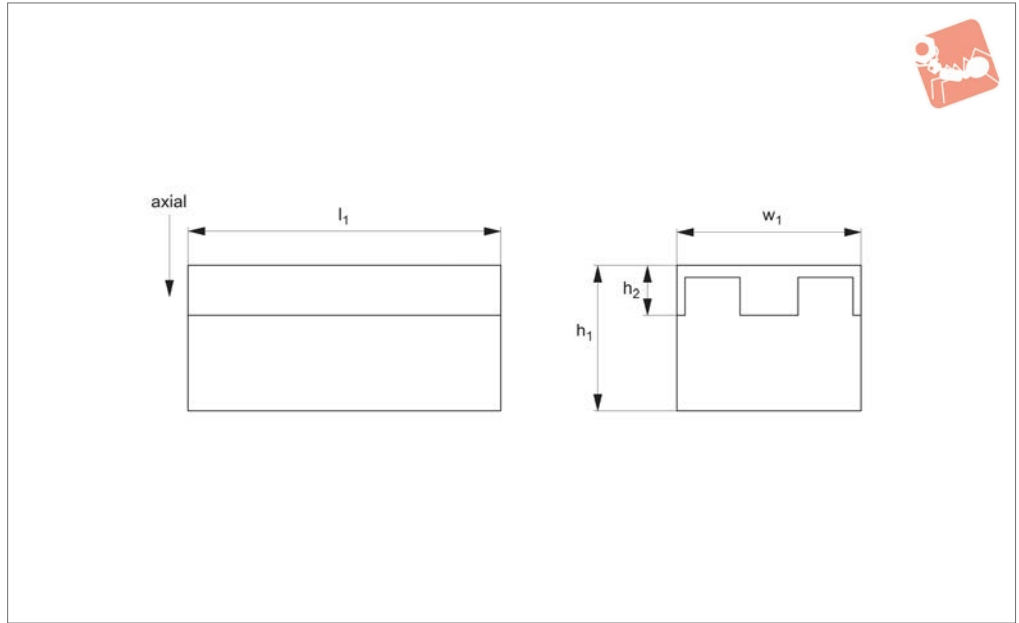

Material

Rubber on silver zinc plated steel (rubber hardness - 60 Shore A).

Technical Notes

The metal plate is provided blank so it can be drilled to suit the number of threads,

thread sizes and the pitch you require. Other sizes can be supplied on request.

Order No.	l_1	w_1	h_1	h_2	Axial load kgf max.
61610.W0060	350	60	40	13	1000
61610.W0061	450	60	40	13	1500
61610.W0062	550	60	40	13	2000

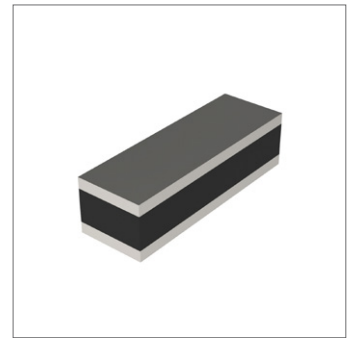
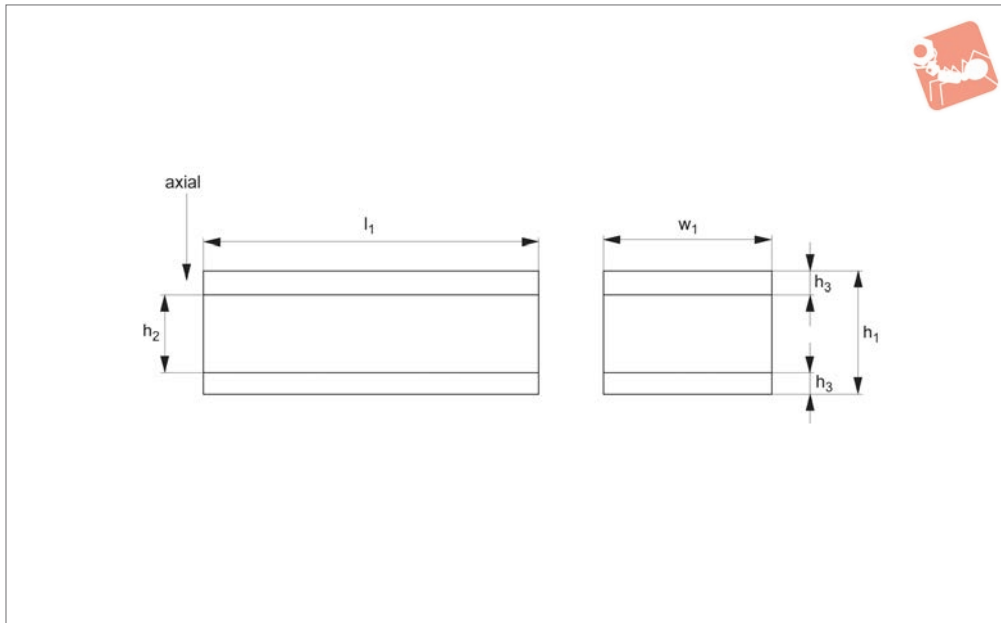

61620

ANTI-VIBRATION

Material

Rubber on silver zinc plated steel (rubber hardness - 60Shore A).

can be drilled to suit the number of threads, thread sizes and the pitch you require. Other sizes can be supplied on request. Suitable for very heavy loads.

Technical Notes

The metal plates are provided blank so they

Order No.	l_1	w_1	h_1	h_2	h_3	Axial load kgf max.
61620.W0040	550	40	40	24	8	2200
61620.W0050	515	50	40	20	10	2800
61620.W0051	515	50	50	30	10	2570
61620.W0060	650	60	50	30	10	3900
61620.W0061	650	60	60	40	10	3500
61620.W0070	600	70	50	30	10	4200
61620.W0171	600	70	55	35	10	4000
61620.W0180	600	80	80	50	15	4320
61620.W0100	415	100	60	30	15	4150
61620.W0101	415	100	80	50	15	3740
61620.W0150	500	150	80	50	15	6750

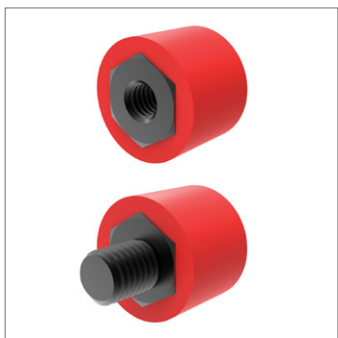

60880

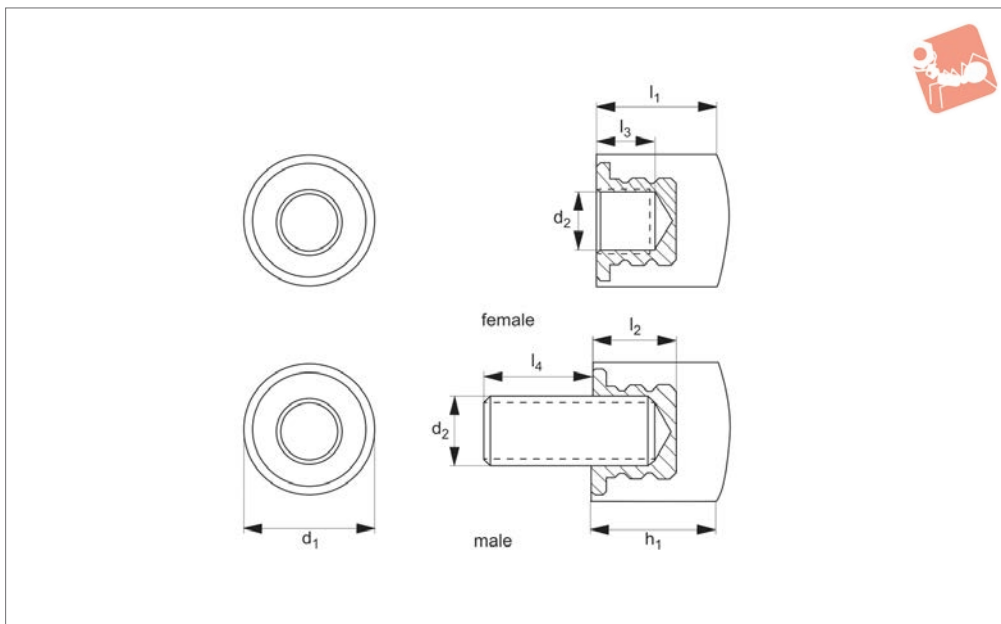

Material

Black Neoprene: flame and weather resistant. Resists: oil, ozone and gasoline. Temperature resistance: -5°C to +93°C (shortly +120°C).

Urethane: highly abrasion resistant, high strength and load bearing. High elonga-

tion and hardness. Resists ozone and oxygen. Temperature resistance: -18°C to +93°C (shortly +120°C).

Technical Notes

Bumpers are moulded to solid steel cores. They are used to guard, stop, align, posi-

tion, or protect parts through stages of manufacturing.

Tips

All dimensions metric.

Order No.	Material	Type	l_1	d_1	d_2	l_2	l_3	l_4	Durometer	Duro. urethane
60880.W0411	Neoprene	Female	16	19	M 6 x 1,00	9.0	6	-	70	80
60880.W0412	Neoprene	Female	16	19	M 8 x 1,25	9.0	6	-	70	80
60880.W0413	Neoprene	Female	32	32	M10 x 1,50	19.0	13	-	40	80
60880.W0414	Neoprene	Female	32	32	M10 x 1,25	19.0	13	-	40	80
60880.W0415	Neoprene	Female	32	32	M12 x 1,75	19.0	13	-	40	80
60880.W0416	Neoprene	Female	32	32	M12 x 1,25	19.0	13	-	40	80
60880.W0417	Neoprene	Female	32	32	M16 x 2,00	19.0	13	-	40	80
60880.W0418	Neoprene	Female	42	45	M16 x 2,00	22.5	16	-	40	80
60880.W0419	Neoprene	Female	57	57	M20 x 2,50	35.0	26	-	40	80
60880.W0420	Neoprene	Female	57	57	M24 x 3,00	35.0	25	-	40	80
60880.W0615	Neoprene	Male	32	32	M10 x 1,50	19.0	-	15	40	80
60880.W0616	Neoprene	Male	32	32	M10 x 1,50	19.0	-	30	40	80
60880.W0617	Neoprene	Male	32	32	M12 x 1,75	19.0	-	15	40	80
60880.W0618	Neoprene	Male	19	32	M12 x 1,75	19.0	-	30	40	80
60880.W0619	Neoprene	Male	32	32	M16 x 2,00	19.0	-	15	40	80
60880.W0620	Neoprene	Male	32	32	M16 x 2,00	19.0	-	30	40	80
60880.W0621	Neoprene	Male	42	45	M16 x 2,00	22.5	-	15	40	80
60880.W0622	Neoprene	Male	42	45	M16 x 2,00	22.5	-	30	40	80
60880.W0451	Urethane	Female	16	19	M 6 x 1,00	9.0	6	-	70	80
60880.W0452	Urethane	Female	16	19	M 8 x 1,25	9.0	6	-	70	80
60880.W0453	Urethane	Female	32	32	M10 x 1,50	19.0	13	-	40	80
60880.W0454	Urethane	Female	32	32	M10 x 1,25	19.0	13	-	40	80
60880.W0455	Urethane	Female	32	32	M12 x 1,75	19.0	13	-	40	80
60880.W0456	Urethane	Female	32	32	M12 x 1,25	19.0	13	-	40	80
60880.W0457	Urethane	Female	32	32	M16 x 2,00	19.0	13	-	40	80
60880.W0458	Urethane	Female	42	45	M16 x 2,00	22.5	16	-	40	80
60880.W0459	Urethane	Female	57	57	M20 x 2,50	35.0	25	-	40	80
60880.W0460	Urethane	Female	57	57	M24 x 3,00	35.0	25	-	40	80
60880.W0635	Urethane	Male	32	32	M10 x 1,50	19.0	-	15	40	80
60880.W0636	Urethane	Male	32	32	M10 x 1,50	19.0	-	30	40	80
60880.W0637	Urethane	Male	32	32	M12 x 1,75	19.0	-	15	40	80



Metric Bumpers - Round male and female

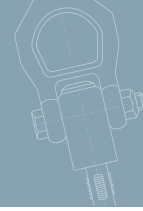

Rollers & Bumpers

Order No.	Material	Type	l_1	d_1	d_2	l_2	l_3	l_4	Durometer	Duro. urethane
60880.W0638	Urethane	Male	19	32	M12 x 1,75	19.0	-	30	40	80
60880.W0639	Urethane	Male	32	32	M16 x 2,00	19.0	-	15	40	80
60880.W0640	Urethane	Male	32	32	M16 x 2,00	19.0	-	30	40	80
60880.W0641	Urethane	Male	42	45	M16 x 2,00	22.5	-	15	40	80
60880.W0642	Urethane	Male	42	45	M16 x 2,00	22.5	-	30	40	80



60890

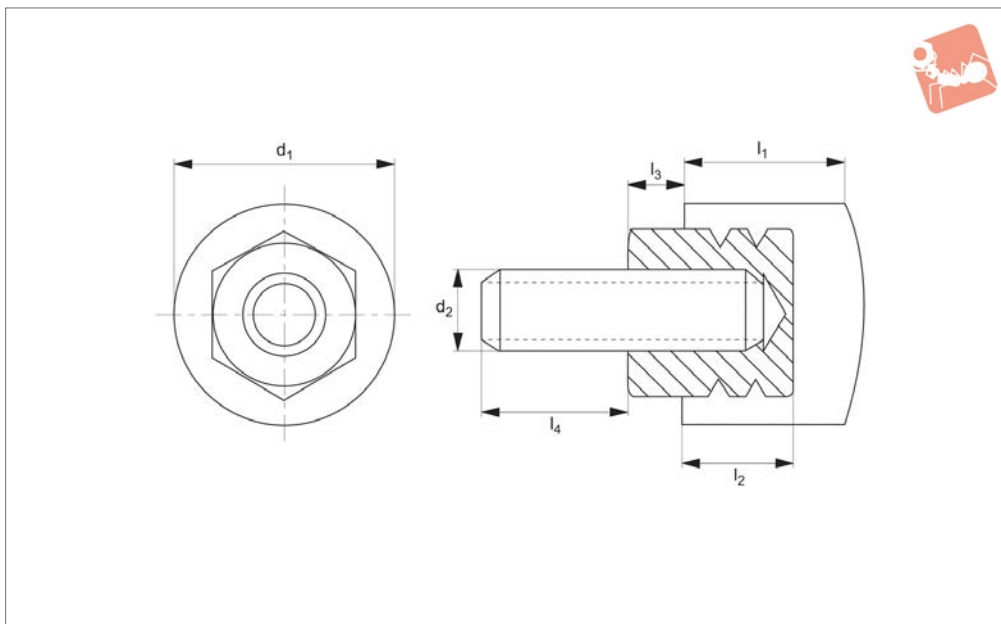

Material

Black Neoprene: flame and weather resistant. Resists: oil, ozone and gasoline. Temperature resistance: -5°C to +93°C (shortly +120°C).

Urethane: highly abrasion resistant, high strength and load bearing. High elonga-

tion and hardness. Resists ozone and oxygen. Temperature resistance: -18°C to +93°C (shortly +120°C).

Technical Notes

Bumpers are moulded to solid steel cores. They are used to guard, stop, align, posi-

tion, or protect parts through stages of manufacturing.

Tips

All dimensions metric.

Order No.	Material	l_1	d_1	d_2	l_2	l_3	l_4
60890.W0501	Neoprene	16	19	M 6 x 1,00	9	3.2	15
60890.W0502	Neoprene	16	19	M 6 x 1,00	9	3.2	30
60890.W0503	Neoprene	16	19	M 8 x 1,25	9	4.0	15
60890.W0504	Neoprene	16	19	M 8 x 1,25	9	4.0	30
60890.W0701	Urethane	16	19	M 6 x 1,00	9	3.2	15
60890.W0702	Urethane	16	19	M 6 x 1,00	9	3.2	30
60890.W0703	Urethane	16	19	M 8 x 1,25	9	4.0	15
60890.W0704	Urethane	16	19	M 8 x 1,25	9	4.0	30

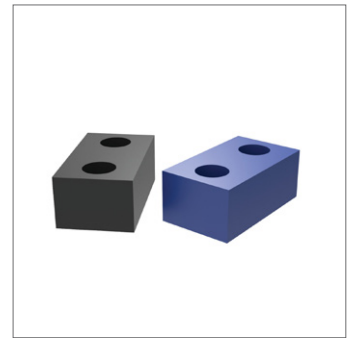
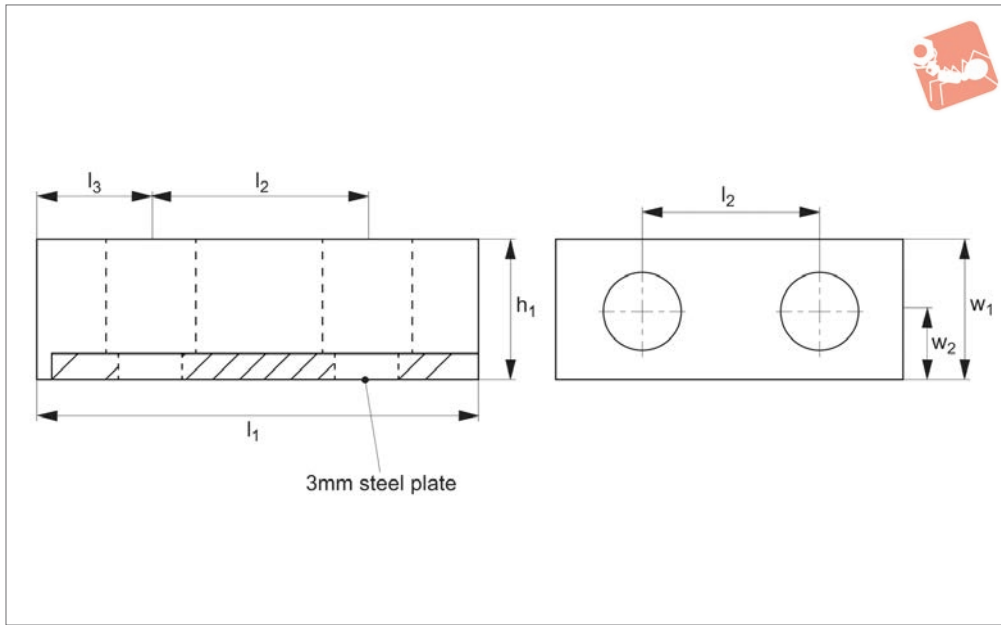
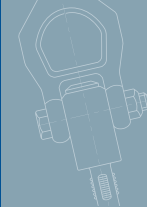

60900

ROLLERS & BUMPERS

Material

Black Neoprene: flame and weather resistant. Resists: oil, ozone and gasoline. Temperature resistance: -5°C to +93°C (shortly +120°C).

Urethane: highly abrasion resistant, high strength and load bearing. High elonga-

tion and hardness. Resists ozone and oxygen. Temperature resistance: -18°C to +93°C (shortly +120°C).

Technical Notes

Bumpers bonded to steel plate. They are used to guard, stop, align, position, or

protect parts through stages of manufacturing.

Tips

All dimensions metric. Special cut bumpers available on request.

Order No.	Material	l_1	d_1	h_1	w_1	l_2	l_3	w_2	Duro.	No. of holes
60900.W0510	Neoprene	44.45	6	19.0	25.4	25.4	9.5	12.7	35	2
60900.W0511	Neoprene	19.0	6	16.0	19.0	-	9.5	9.5	80	1
60900.W0512	Neoprene	63.5	6	16.0	16.0	38.1	12.7	7.9	80	2
60900.W0515	Neoprene	44.45	6	19.0	25.4	25.4	9.5	12.7	80	2
60900.W0516	Neoprene	50.8	-	50.8	50.8	-	-	-	80	-
60900.W0701	Urethane	19.0	6	16.0	19.0	-	9.5	9.5	60	1
60900.W0702	Urethane	63.5	6	16.0	16.0	38.1	12.7	7.9	60	2
60900.W0703	Urethane	44.45	6	9.5	25.4	25.4	9.5	12.7	60	2
60900.W0704	Urethane	44.45	6	12.7	25.4	25.4	9.5	12.7	60	2
60900.W0705	Urethane	44.45	6	19.0	25.4	25.4	9.5	12.7	60	2
60900.W0711	Urethane	19.0	6	16.0	19.0	-	9.5	9.5	80	1
60900.W0712	Urethane	63.5	6	16.0	16.0	38.1	12.7	7.9	80	2
60900.W0713	Urethane	44.45	6	9.5	25.4	25.4	9.5	12.7	80	2
60900.W0714	Urethane	44.45	6	12.7	25.4	25.4	9.5	12.7	80	2
60900.W0715	Urethane	44.45	6	19.0	25.4	25.4	9.5	12.7	80	2
60900.W0716	Urethane	50.8	-	50.8	50.8	-	-	-	80	-

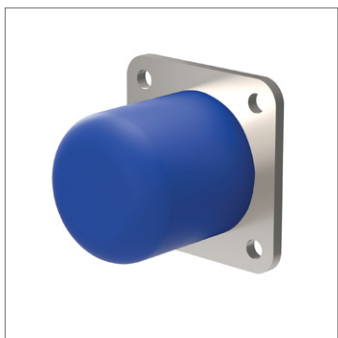

60910

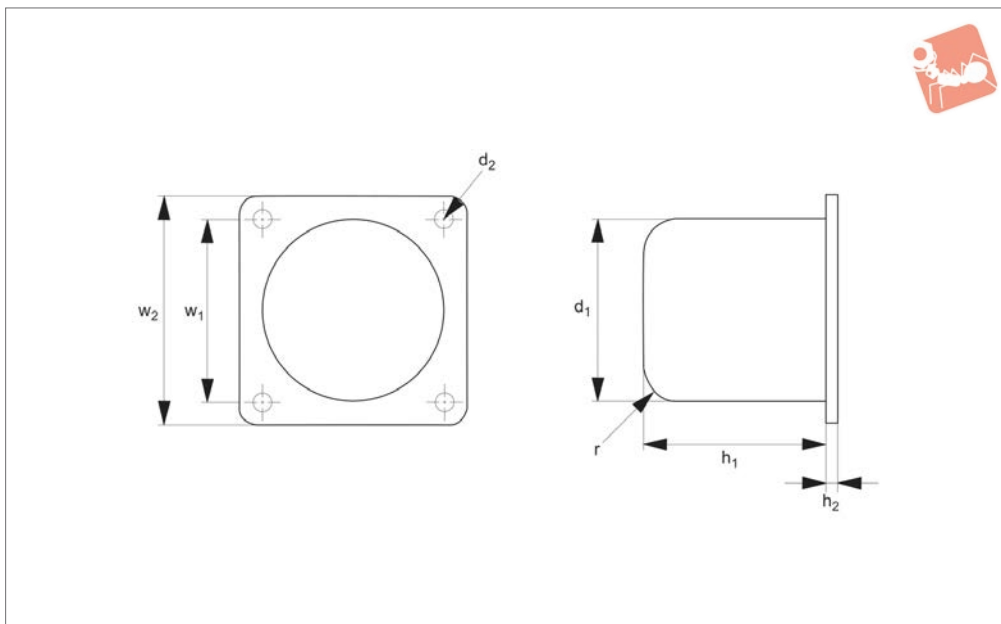

Material

Urethane: highly abrasion resistant, high strength and load bearing. High elongation and hardness. Resists ozone and oxygen. Temperature resistance: -18°C to

+93°C (shortly +120°C).

Technical Notes

Used for stops, guides, bumpers and protection. Moulded urethane bonded to

steel plate.

Tips

All dimensions metric.

Order No.	d ₁	h ₁	w ₁	d ₂	l ₂	w ₂	R	Durometer
60910.W0701	50.8	50.8	50.8	7.13	4.76	63.50	9.53	60
60910.W0702	63.5	63.5	63.5	7.13	4.76	82.55	12.70	60
60910.W0703	76.2	76.2	76.2	10.31	6.35	101.60	15.88	60
60910.W0704	101.6	101.6	101.6	10.31	6.35	127.00	19.05	60
60910.W0711	50.8	50.8	50.8	7.13	4.76	63.50	9.53	80
60910.W0712	63.5	63.5	63.5	7.13	4.76	82.55	12.70	80
60910.W0713	76.2	76.2	76.2	10.31	6.35	101.60	15.88	80
60910.W0714	101.6	101.6	101.6	10.31	6.35	127.00	19.05	80



Wixroyd Rollers

Product overview



Solid rollers - have a smooth surface and a solid body

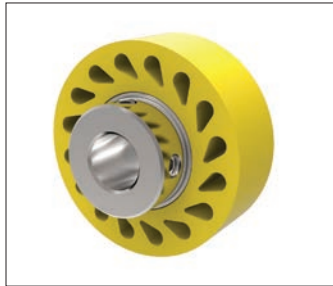

Durossoft rollers - have a smooth contact surface with teardrop holes to allow greater roller compression under load.



Finned rollers - are grooved and provide self-cleaning as dirt, debris and liquid pass under the contact surface of the roller.

Durability levels



20 durometer:
Stiff foam rubber



35 durometer:
Pencil rubber top



60 durometer:
Car tyre



80 durometer:
Skateboard wheel



90 durometer:
Hockey puck

Applications

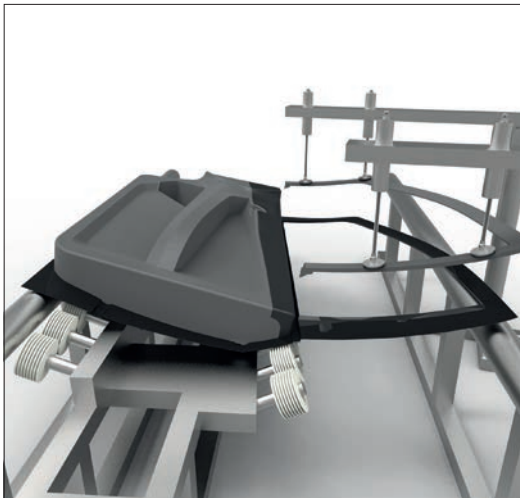

Rollers are used in car manufacturing to guide and align doors during bonding and curing applications



Bumpers have found their way into commercial exercise equipment to provide protection and stability during use.



Materials colour guide and properties

Nitrile and neoprene



Nitrile - one colour



Neoprene - one colour

Urethane



35 Durometer (Yellow)



60 Durometer (Blue)



80 Durometer (Red)



95 Durometer (Orange)

Material properties

Base Elastomer	Chemical Name	Advantages	Disadvantages	Max. Temp	Min. Temp
Nitrile	Nitrile Butadiene	Resistant to petroleum, oil, alcohol & abrasion.	Affected by degreaser solvents.	Continuous 79°C Intermittent 107°C	-51°C
Neoprene	Chloroprene	Flame and weather resistant. Resistant to Petroleum, oil, ozone & high temp.	Affected by phosphate hydraulic fluids, aromatic hydrocarbons.	Continuous 93°C Intermittent 121°C	-40°C
Urethane	Di-Isocyanate Polyurethane	Highest abrasion resistance, strength & load bearing. High elongation, hardness. Resistance to Ozone & Oxygen.	Affected by ether, esters, acid, aromatics, alkalis.	Continuous 93°C Intermittent 121°C	-54°C

Property:	Nitrile	Neoprene	Urethane	
Tensile Strength	✓ ✓	✓ ✓ ✓	✓ ✓ ✓ ✓	
Ozone Resistance	✓	✓ ✓	✓ ✓ ✓ ✓	
Cut Resistance	✓ ✓	✓ ✓ ✓	✓ ✓ ✓ ✓	
Abrasion Resistance	✓ ✓	✓ ✓ ✓	✓ ✓ ✓ ✓	
Resistance To:	Nitrile	Neoprene	Urethane	
Compression Set	✓ ✓	✓ ✓ ✓	✓ ✓ ✓	
ASTM #1 Oil	✓ ✓ ✓ ✓	✓ ✓	✓ ✓ ✓ ✓	
ASTM #2 Oil	✓ ✓ ✓ ✓	✓ ✓	✓ ✓ ✓ ✓	
Reference Fuel B	✓ ✓ ✓	✓ ✓	✓ ✓ ✓ ✓	
Ketones: MEK	✓	✓ ✓	✓	
Aromatics: Toluene	✓ ✓ ✓	✓	✓ ✓ ✓ ✓	
Aliphatics: Hexane	✓ ✓ ✓ ✓	✓ ✓ ✓	✓ ✓ ✓ ✓	
Ethyl Acetate	✓	✓ ✓ ✓	✓	
Cellosolve	✓ ✓	✓ ✓ ✓ ✓	✓	
Methylene Chloride	✓	✓	✓ ✓ ✓ ✓	
Trichloroethylene	✓	✓	✓ ✓ ✓ ✓	
Diethylene Glycol	✓ ✓ ✓ ✓	✓ ✓ ✓ ✓	✓ ✓ ✓	
Isopropyl Alcohol	✓ ✓ ✓	✓ ✓ ✓	✓ ✓ ✓	
Caustics: 10% NaOH	✓ ✓ ✓	✓ ✓ ✓	✓	
Acids: H2SO4	✓ ✓	✓ ✓ ✓	✓	
Excellent	✓ ✓ ✓ ✓	Good ✓ ✓ ✓	Fair ✓ ✓	Poor ✓



The tables below show the maximum theoretical radius loads that can be applied to the respective bearings. Refer to individual product tables to identify bearing type supplied with roller.

Bearing Type	Inside diameter (inches)	Outside diameter (inches)	Width (inches)	Load (Kg)	Speed (rpm)
A - Standard Double	.313/.317	.870/.875	.498/.502	55	50
				36	100
				24	250
				20	500
B - Standard Single	.500/.505	1.245/1.250	.370/.380	119	50
				79	100
				51	250
				47	500
C - Standard Double	.500/.505	1.245/1.250	.745/.755	192	50
				128	100
				83	250
				70	500

Standard bearings

With the calculations above, typical life is approximately 2500 hours.

Bearing Type	Inside diameter (inches)	Outside diameter (inches)	Width (inches)	Load (Kg)	Speed (rpm)
H	.3745/.3750	.6245/.6255	.865/.875	167	33
				146	50
				116	100
				85	250
I	.6245/.6250	.8745/.8755	.990/1.000	277	33
				242	50
				192	100
				142	250

Clutch bearings

With the calculations above, typical life is approximately 1,000,000 revolutions or 500 hours. The bearings are shielded and pre-lubricated for life with grease.

A clutch roller can only be used in one direction, as shown. See data table for clutch direction of particular part.

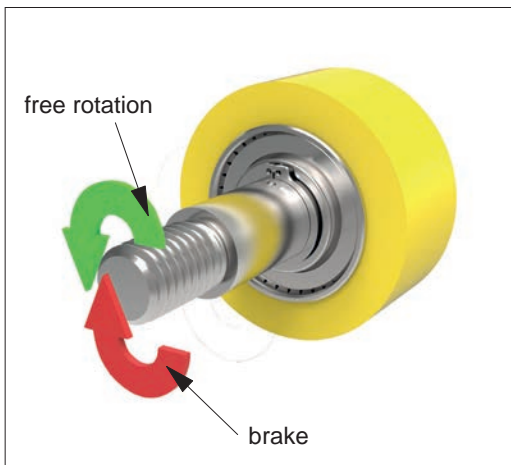

Left clutch bearing

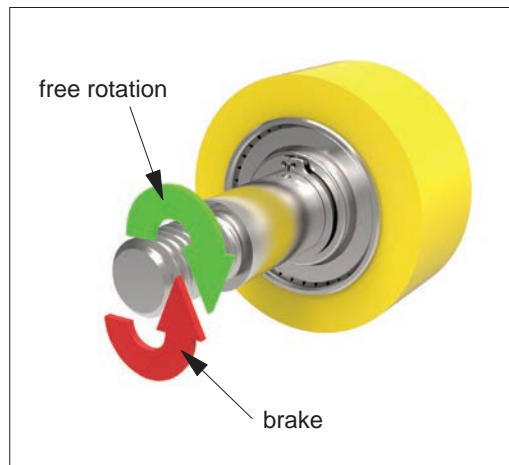

Right clutch bearing

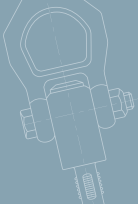

60640

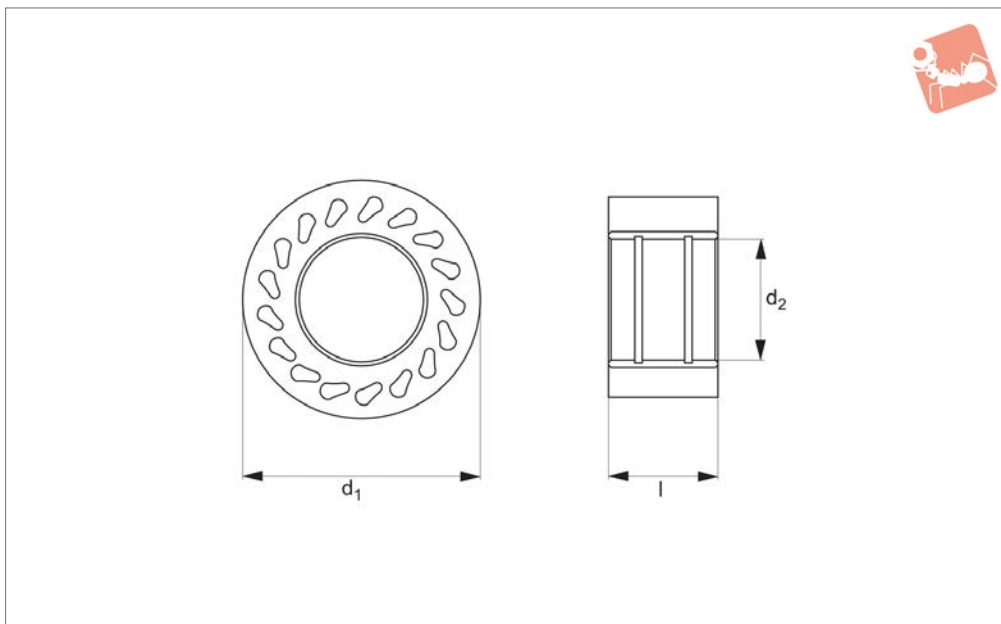

Material

Urethane bonded to a steel insert. Hardness from 35-95 durometer (Shore A).

Technical Notes

Roller only - allows for custom mounting.

Tips

Durasoft rollers have „teardrop“ holes to allow the roller to flex for firm but non-damaging contact.

Order No.	Durometer	d ₁	l	d ₂ min. max.
60640.W1003	35	63,5 (2,5")	23.37	28,58/28,65
60640.W1006	60	63,5 (2,5")	23.37	28,58/28,65
60640.W1008	80	63,5 (2,5")	23.37	28,58/28,65
60640.W1009	95	63,5 (2,5")	23.37	28,58/28,68
60640.W1013	35	63,5 (2,5")	49.28	31,80/31,90
60640.W1016	60	63,5 (2,5")	49.28	31,80/31,90
60640.W1018	80	63,5 (2,5")	49.28	31,80/31,90
60640.W1019	95	63,5 (2,5")	49.28	31,80/31,90
60640.W1023	35	101,6 (4")	23.37	31,80/31,90
60640.W1026	60	101,6 (4")	23.37	31,80/31,90
60640.W1028	80	101,6 (4")	23.37	31,80/31,90
60640.W1029	95	101,6 (4")	23.37	31,80/31,90
60640.W1033	35	101,6 (4")	49.28	31,80/31,90
60640.W1036	60	101,6 (4")	49.28	31,80/31,90
60640.W1038	80	101,6 (4")	49.28	31,80/31,90
60640.W1039	95	101,6 (4")	49.28	31,80/31,90

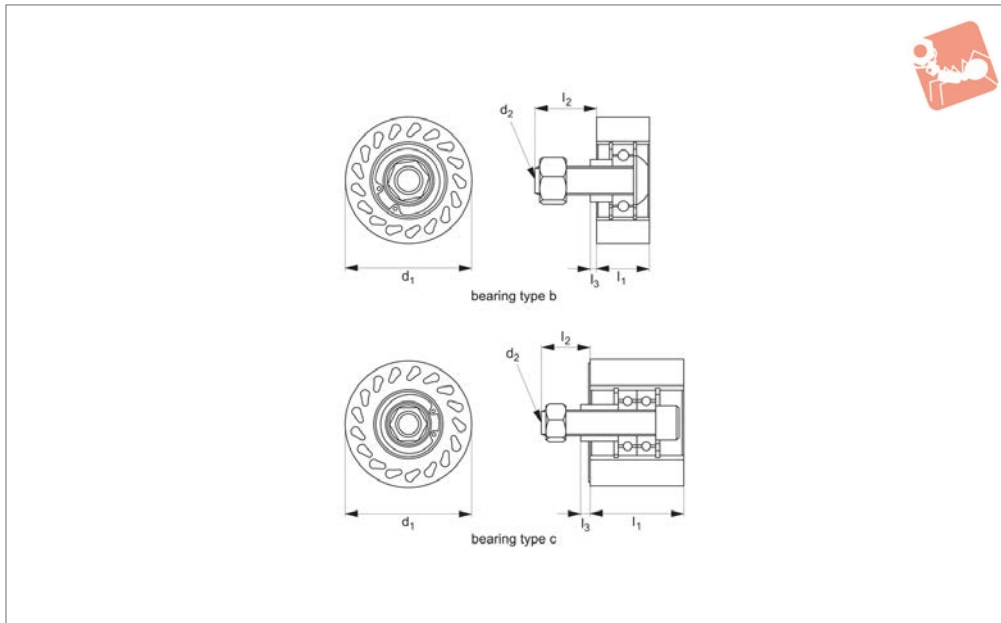

60644

ROLLERS & BUMPERS

Material

Urethane bonded to a steel insert. Hardness from 35-80 durometer (Shore A).

Assembled with socket head cap screw, spacer and lock nut.

allow the roller to flex for firm but non-damaging contact.

Technical Notes

Bearings included (held in place with snap

Tips

Durasoft rollers have „teardrop“ holes to

Order No.	Durometer	d ₁	l ₁	d ₂	l ₂	l ₃	Bearing type
60644.W1003	35	62,5 (2,5")	23.37	1/2-13	27.94	3.05	B
60644.W1006	60	62,5 (2,5")	23.37	1/2-13	27.94	3.05	B
60644.W1008	80	62,5 (2,5")	23.37	1/2-13	27.94	3.05	B
60644.W1013	35	62,5 (2,5")	49.28	1/2-13	35.81	6.35	C
60644.W1016	60	62,5 (2,5")	49.28	1/2-13	35.81	6.35	C
60644.W1018	80	62,5 (2,5")	49.28	1/2-13	35.81	6.35	C
60644.W1023	35	101,6 (4")	23.37	1/2-13	27.94	3.05	B
60644.W1026	60	101,6 (4")	23.37	1/2-13	27.94	3.05	B
60644.W1028	80	101,6 (4")	23.37	1/2-13	27.94	3.05	B
60644.W1033	35	101,6 (4")	49.28	1/2-13	35.81	6.35	C
60644.W1036	60	101,6 (4")	49.28	1/2-13	35.81	6.35	C
60644.W1038	80	101,6 (4")	49.28	1/2-13	35.81	6.35	C

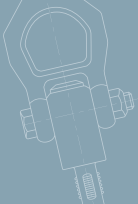

60646

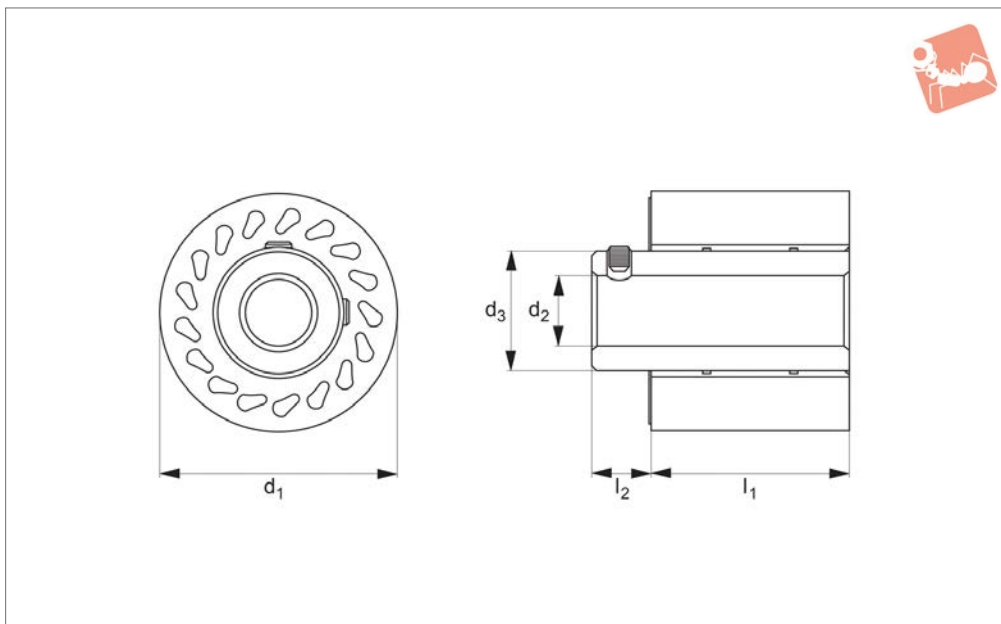

Material

Urethane bonded to a steel insert. Hardness from 35-80 durometer (Shore A).

Technical Notes

Designed to be mounted onto a shaft. A

hub extends past the roller and is supplied with two set screws at 90°.

damaging contact.

Tips

Durasoft rollers have „teardrop” holes to allow the roller to flex for firm but non-

Order No.	Durometer	d ₁	l ₁	d ₂ min. max.	l ₂	d ₃
60646.W1003	35	63,5 (2,5")	23.37	12,73/12,83	12.7	31.75
60646.W1006	60	63,5 (2,5")	23.37	12,73/12,83	12.7	31.75
60646.W1008	80	63,5 (2,5")	23.37	12,73/12,83	12.7	31.75
60646.W1009	95	63,5 (2,5")	23.37	12,73/12,83	12.7	31.75
60646.W1013	35	63,5 (2,5")	23.37	15,90/16,03	12.7	31.75
60646.W1016	60	63,5 (2,5")	23.37	15,90/16,03	12.7	31.75
60646.W1018	80	63,5 (2,5")	23.37	15,90/16,03	12.7	31.75
60646.W1019	95	63,5 (2,5")	23.37	15,90/16,03	12.7	31.75
60646.W1023	35	63,5 (2,5")	23.27	19,08/19,20	12.7	31.75
60646.W1026	60	63,5 (2,5")	23.27	19,08/19,20	12.7	31.75
60646.W1028	80	63,5 (2,5")	23.27	19,08/19,20	12.7	31.75
60646.W1029	95	63,5 (2,5")	23.27	19,08/19,20	12.7	31.75

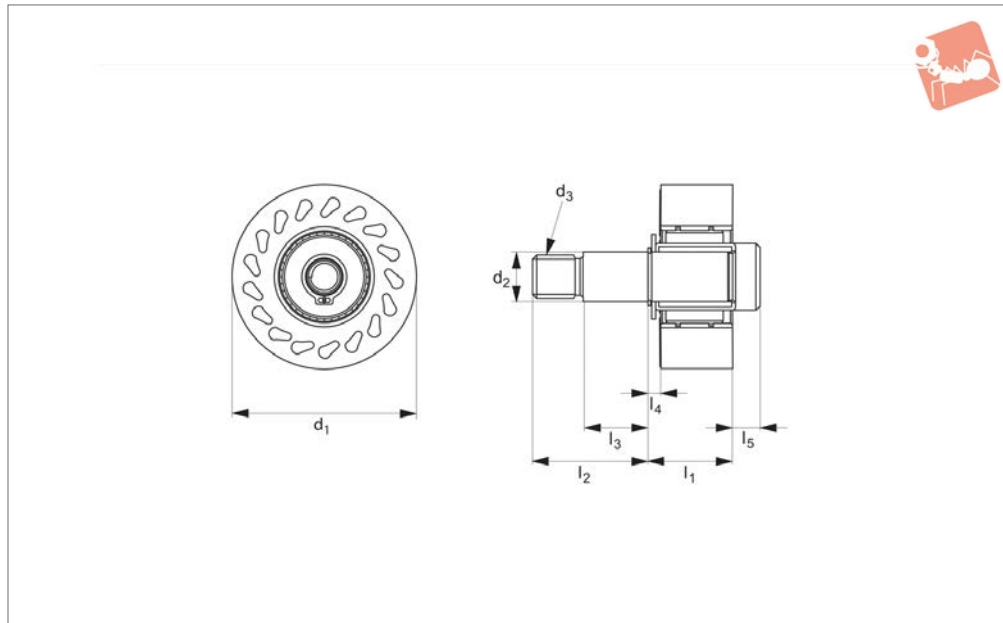
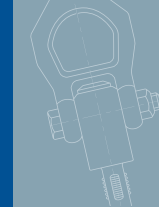
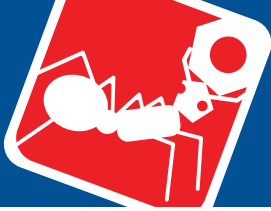

60648

ROLLERS & BUMPERS

Material

Urethane bonded to a steel insert. Hardness from 35-80 durometer (Shore A).

Technical Notes

A clutch bearing allows the roller to turn in only one direction. Available in left or right

hand rotation (with the stud pointed upwards, a right hand rotation turns clockwise).

Type R= right hand clutch bearing.

Type L= left hand clutch bearing.

Tips

Durasoft rollers have „teardrop“ holes to allow the roller to flex for firm but non-damaging contact. All clutch bearing are type I. Please see technical page for more information on the bearing.

Order No.	Type	Durometer	d ₁	l ₁	d ₂ min. max.	l ₂	d ₃	l ₃	l ₄	l ₅
60648.W1003	R	35	63,50 (2,5")	23.37	15,77/15,82	45.47	1/2-13"	26.42	3.05	10.41
60648.W1006	R	60	63,50 (2,5")	23.37	15,77/15,82	45.47	1/2-13"	26.42	3.05	10.41
60648.W1008	R	80	63,50 (2,5")	23.37	15,77/15,82	45.47	1/2-13"	26.42	3.05	10.41
60648.W1013	L	35	63,50 (2,5")	23.37	15,77/15,82	45.47	1/2-13"	26.42	3.05	10.41
60648.W1016	L	60	63,50 (2,5")	23.37	15,77/15,82	45.47	1/2-13"	26.42	3.05	10.41
60648.W1018	L	80	63,50 (2,5")	23.37	15,77/15,82	45.47	1/2-13"	26.42	3.05	10.41
60648.W1023	R	35	63,50 (2,5")	49.28	15,77/15,82	31.75	1/2-13"	12.70	10.92	-
60648.W1026	R	60	63,50 (2,5")	49.28	15,77/15,82	31.75	1/2-13"	12.70	10.92	-
60648.W1028	R	80	63,50 (2,5")	49.28	15,77/15,82	31.75	1/2-13"	12.70	10.92	-
60648.W1033	L	35	63,50 (2,5")	49.28	15,77/15,82	31.75	1/2-13"	12.70	10.92	-
60648.W1036	L	60	63,50 (2,5")	49.28	15,77/15,82	31.75	1/2-13"	12.70	10.92	-
60648.W1038	L	80	63,50 (2,5")	49.28	15,77/15,82	31.75	1/2-13"	12.70	10.92	-
60648.W1043	R	35	101,60 (4")	23.37	15,77/15,82	45.47	1/2-13"	26.42	3.05	10.41
60648.W1046	R	60	101,60 (4")	23.37	15,77/15,82	45.47	1/2-13"	26.42	3.05	10.41
60648.W1048	R	80	101,60 (4")	23.37	15,77/15,82	45.47	1/2-13"	26.42	3.05	10.41
60648.W1053	L	35	101,60 (4")	23.37	15,77/15,82	45.47	1/2-13"	26.42	3.05	10.41
60648.W1056	L	60	101,60 (4")	23.37	15,77/15,82	45.47	1/2-13"	26.42	3.05	10.41
60648.W1058	L	80	101,60 (4")	23.37	15,77/15,82	45.47	1/2-13"	26.42	3.05	10.41
60648.W1063	R	35	101,60 (4")	49.28	15,77/15,82	31.75	1/2-13"	12.70	10.92	-
60648.W1066	R	60	101,60 (4")	49.28	15,77/15,82	31.75	1/2-13"	12.70	10.92	-
60648.W1068	R	80	101,60 (4")	49.28	15,77/15,82	31.75	1/2-13"	12.70	10.92	-
60648.W1073	L	35	101,60 (4")	49.28	15,77/15,82	31.75	1/2-13"	12.70	10.92	-
60648.W1076	L	60	101,60 (4")	49.28	15,77/15,82	31.75	1/2-13"	12.70	10.92	-
60648.W1078	L	80	101,60 (4")	49.28	15,77/15,82	31.75	1/2-13"	12.70	10.92	-

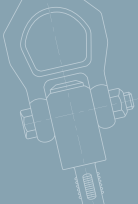

60680

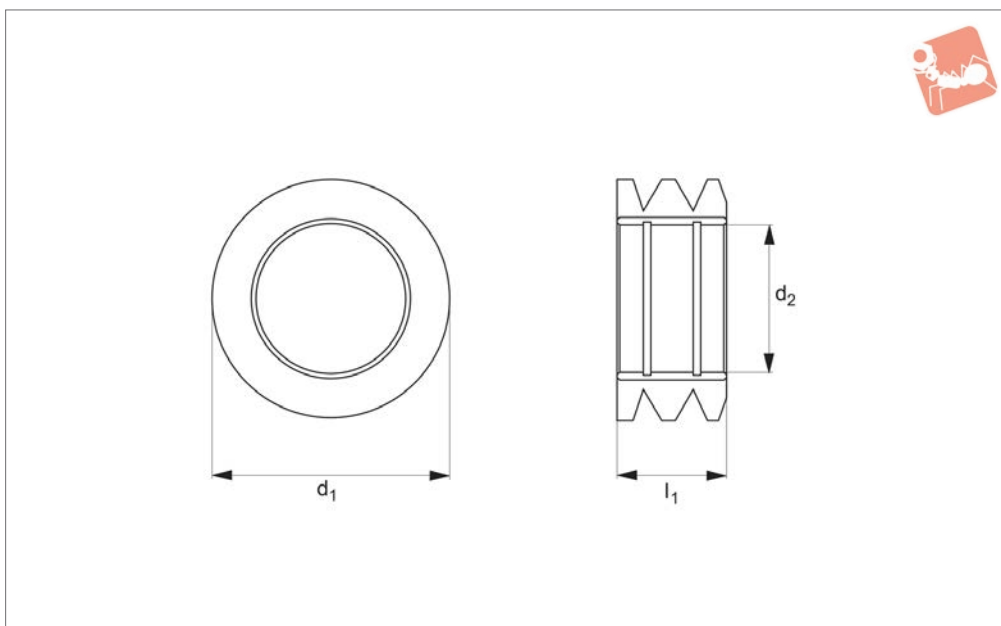

Material

Nitrile, urethane or neoprene bonded to a steel insert. Hardness from 20-60 durometer (Shore A).

Tips

Finned rollers have grooves on the surface, creating less surface contact with the workpiece, and allowing dirt, debris and liquid to pass.

Technical Notes

Roller only - allows for custom mounting.

Order No.	Material	Durometer	d ₁	l ₁	d ₂ min. max.	No. of fins
60680.W1002	Nitrile	20	50,8 (2")	23.37	28,58/28,65	3
60680.W1003	Nitrile	35	50,8 (2")	23.37	28,58/28,65	3
60680.W1006	Nitrile	60	50,8 (2")	23.37	28,58/28,65	3
60680.W1012	Nitrile	20	50,8 (2")	23.37	28,58/28,65	3
60680.W1013	Nitrile	35	50,8 (2")	23.37	28,58/28,65	3
60680.W1016	Nitrile	60	50,8 (2")	23.37	28,58/28,65	3
60680.W1022	Nitrile	20	50,8 (2")	23.37	28,58/28,65	3
60680.W1023	Nitrile	35	50,8 (2")	23.37	28,58/28,65	3
60680.W1026	Nitrile	60	50,8 (2")	23.37	31,80/31,90	3
60680.W1032	Nitrile	20	50,8 (2")	23.37	31,80/31,90	3
60680.W1033	Nitrile	35	50,8 (2")	23.37	31,80/31,90	3
60680.W1036	Nitrile	60	50,8 (2")	23.37	31,80/31,90	3
60680.W1042	Nitrile	20	50,8 (2")	23.37	31,80/31,90	3
60680.W1043	Nitrile	35	50,8 (2")	23.37	31,80/31,90	3
60680.W1046	Nitrile	60	50,8 (2")	23.37	31,80/31,90	3
60680.W1052	Nitrile	20	50,8 (2")	23.37	31,80/31,90	3
60680.W1053	Nitrile	35	50,8 (2")	49.28	28,58/28,65	6
60680.W1056	Nitrile	60	50,8 (2")	49.28	28,58/28,65	6
60680.W1062	Nitrile	20	50,8 (2")	49.28	28,58/28,65	6
60680.W1063	Nitrile	35	50,8 (2")	49.28	28,58/28,65	6
60680.W1066	Nitrile	60	50,8 (2")	49.28	28,58/28,65	6
60680.W1072	Nitrile	20	50,8 (2")	49.28	28,58/28,65	6
60680.W1073	Nitrile	35	50,8 (2")	49.28	28,58/28,65	6
60680.W1076	Nitrile	60	50,8 (2")	49.28	28,58/28,65	6
60680.W1083	Nitrile	35	50,8 (2")	49.28	31,80/31,90	6
60680.W1086	Nitrile	60	50,8 (2")	49.28	31,80/31,90	6
60680.W1093	Nitrile	35	50,8 (2")	49.28	31,80/31,90	6
60680.W1096	Nitrile	60	50,8 (2")	49.28	31,80/31,90	6
60680.W2003	Urethane	35	50,8 (2")	49.28	31,80/31,90	6
60680.W2006	Urethane	60	50,8 (2")	49.28	31,80/31,90	6
60680.W2013	Urethane	35	50,8 (2")	49.28	31,80/31,90	6



Finned Roller roller only



Rollers & Bumpers

Order No.	Material	Durometer	d ₁	l ₁	d ₂ min./max.	No. of fins
60680.W2016	Urethane	60	50,8 (2")	49.28	31,80/31,90	6
60680.W2023	Urethane	35	50,8 (2")	23.37	28,58/28,65	3
60680.W2026	Urethane	60	50,8 (2")	23.37	28,58/28,65	3
60680.W2033	Urethane	35	50,8 (2")	23.37	28,58/28,65	3
60680.W2036	Urethane	60	50,8 (2")	23.37	28,58/28,65	3
60680.W2043	Urethane	35	50,8 (2")	23.37	28,58/28,65	3
60680.W2046	Urethane	60	50,8 (2")	23.37	28,58/28,65	3
60680.W2053	Urethane	35	50,8 (2")	23.37	28,58/28,65	3
60680.W2056	Urethane	60	50,8 (2")	23.37	28,58/28,65	3
60680.W2063	Urethane	35	63,5 (2,5")	23.37	31,80/31,90	3
60680.W2066	Urethane	60	63,5 (2,5")	23.37	31,80/31,90	3
60680.W2073	Urethane	35	63,5 (2,5")	23.37	31,80/31,90	3
60680.W2076	Urethane	60	63,5 (2,5")	23.37	31,80/31,90	3
60680.W2083	Urethane	35	63,5 (2,5")	23.37	31,80/31,90	3
60680.W2086	Urethane	60	63,5 (2,5")	23.37	31,80/31,90	3
60680.W2093	Urethane	35	63,5 (2,5")	23.37	31,80/31,90	3
60680.W2096	Urethane	60	63,5 (2,5")	23.37	31,80/31,90	3
60680.W3002	Neoprene	20	63,5 (2,5")	49.28	28,58/28,65	6
60680.W3003	Neoprene	35	63,5 (2,5")	49.28	28,58/28,65	6
60680.W3006	Neoprene	60	63,5 (2,5")	49.28	28,58/28,65	6
60680.W3012	Neoprene	20	63,5 (2,5")	49.28	28,58/28,65	6
60680.W3013	Neoprene	35	63,5 (2,5")	49.28	28,58/28,65	6
60680.W3016	Neoprene	60	63,5 (2,5")	49.28	28,58/28,65	6
60680.W3022	Neoprene	20	63,5 (2,5")	49.28	28,58/28,65	6
60680.W3023	Neoprene	35	63,5 (2,5")	49.28	28,58/28,65	6
60680.W3026	Neoprene	60	63,5 (2,5")	49.28	31,80/31,90	6
60680.W3032	Neoprene	20	63,5 (2,5")	49.28	31,80/31,90	6
60680.W3033	Neoprene	35	63,5 (2,5")	49.28	31,80/31,90	6
60680.W3036	Neoprene	60	63,5 (2,5")	49.28	31,80/31,90	6
60680.W3042	Neoprene	20	63,5 (2,5")	49.28	31,80/31,90	6
60680.W3043	Neoprene	35	63,5 (2,5")	49.28	31,80/31,90	6
60680.W3046	Neoprene	60	63,5 (2,5")	49.28	31,80/31,90	6
60680.W3052	Neoprene	20	63,5 (2,5")	49.28	31,80/31,90	6
60680.W3053	Neoprene	35	101,6 (4")	49.28	28,58/28,65	8
60680.W3056	Neoprene	60	101,6 (4")	49.28	28,58/28,65	8
60680.W3062	Neoprene	20	101,6 (4")	49.28	28,58/28,65	8
60680.W3063	Neoprene	35	101,6 (4")	49.28	28,58/28,65	8
60680.W3066	Neoprene	60	101,6 (4")	49.28	28,58/28,65	8
60680.W3072	Neoprene	20	101,6 (4")	49.28	28,58/28,65	8
60680.W3073	Neoprene	35	101,6 (4")	49.28	31,80/31,90	8
60680.W3076	Neoprene	60	101,6 (4")	49.28	31,80/31,90	8
60680.W3083	Neoprene	35	101,6 (4")	49.28	31,80/31,90	8
60680.W3086	Neoprene	60	101,6 (4")	49.28	31,80/31,90	8
60680.W3093	Neoprene	35	101,6 (4")	49.28	31,80/31,90	8
60680.W3096	Neoprene	60	101,6 (4")	49.28	31,80/31,90	8

ROLLERS & BUMPERS

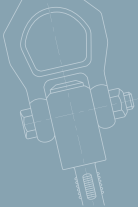

60682

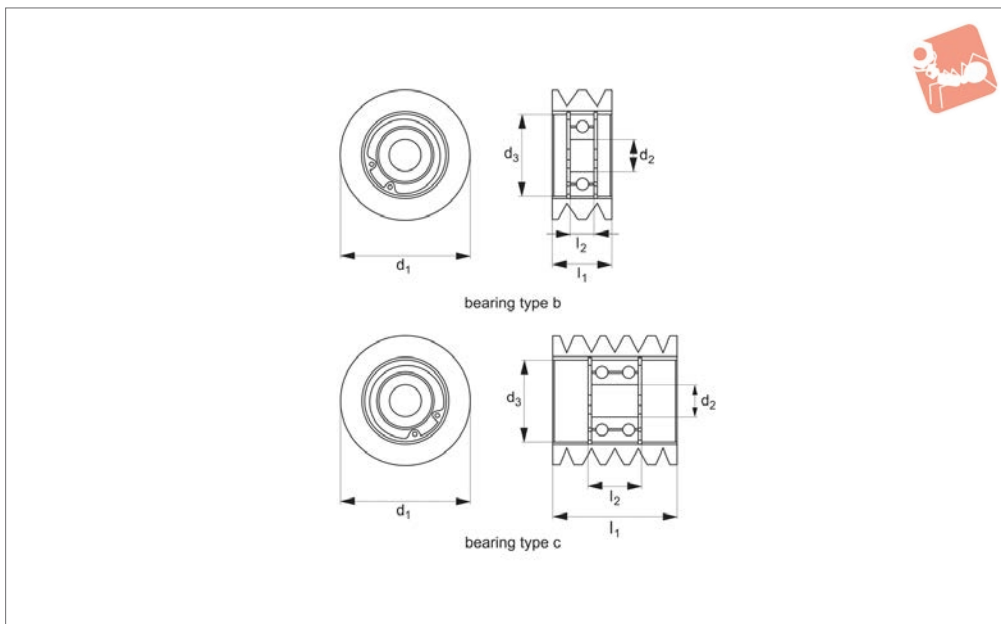

Material

Nitrile, urethane or neoprene bonded to a steel insert. Hardness from 20-60 durometer (Shore A).

Technical Notes

Bearings included (held in place with snap

rings). For more details on bearings please see technical pages.

Tips

Finned rollers have grooves on the surface, creating less surface contact with the workpiece, and allowing dirt, debris and

liquid to pass.

Order No.	Material	Durometer	Bearing type	d ₁	l ₁	d ₂ -0 +0.13	d ₃ -0 +0.13	l ₂ -0 +0.13	No. of fins
60682.W1002	Nitrile	20	B	50,8 (2")	23.37	12.7	31.62	9.40	3
60682.W1003	Nitrile	35	B	50,8 (2")	23.37	12.7	31.62	9.40	3
60682.W1006	Nitrile	60	B	50,8 (2")	23.37	12.7	31.62	9.40	3
60682.W1012	Nitrile	20	C	50,8 (2")	49.28	12.7	31.62	18.92	6
60682.W1013	Nitrile	35	C	50,8 (2")	49.28	12.7	31.62	18.92	6
60682.W1016	Nitrile	60	C	50,8 (2")	49.28	12.7	31.62	18.92	6
60682.W1022	Nitrile	20	B	63,5 (2,5")	23.37	12.7	31.62	9.40	3
60682.W1023	Nitrile	35	B	63,5 (2,5")	23.37	12.7	31.62	9.40	3
60682.W1026	Nitrile	60	B	63,5 (2,5")	23.37	12.7	31.62	9.40	3
60682.W2003	Urethane	35	B	50,8 (2")	23.37	12.7	31.62	9.40	3
60682.W2006	Urethane	60	B	50,8 (2")	23.37	12.7	31.62	9.40	3
60682.W2013	Urethane	35	C	50,8 (2")	49.28	12.7	31.62	18.92	6
60682.W2016	Urethane	60	C	50,8 (2")	49.28	12.7	31.62	18.92	6
60682.W2023	Urethane	35	B	63,5 (2,5")	23.37	12.7	31.62	9.40	3
60682.W2026	Urethane	60	B	63,5 (2,5")	23.37	12.7	31.62	9.40	3
60682.W3002	Neoprene	20	B	50,8 (2")	23.37	12.7	31.62	9.40	3
60682.W3003	Neoprene	35	B	50,8 (2")	23.37	12.7	31.62	9.40	3
60682.W3006	Neoprene	60	B	50,8 (2")	23.37	12.7	31.62	9.40	3
60682.W3012	Neoprene	20	C	50,8 (2")	49.28	12.7	31.62	18.92	6
60682.W3013	Neoprene	35	C	50,8 (2")	49.28	12.7	31.62	18.92	6
60682.W3016	Neoprene	60	C	50,8 (2")	49.28	12.7	31.62	18.92	6
60682.W3022	Neoprene	20	B	63,5 (2,5")	23.37	12.7	31.62	9.40	3
60682.W3023	Neoprene	35	B	63,5 (2,5")	23.37	12.7	31.62	9.40	3
60682.W3026	Neoprene	60	B	63,5 (2,5")	23.37	12.7	31.62	9.40	3

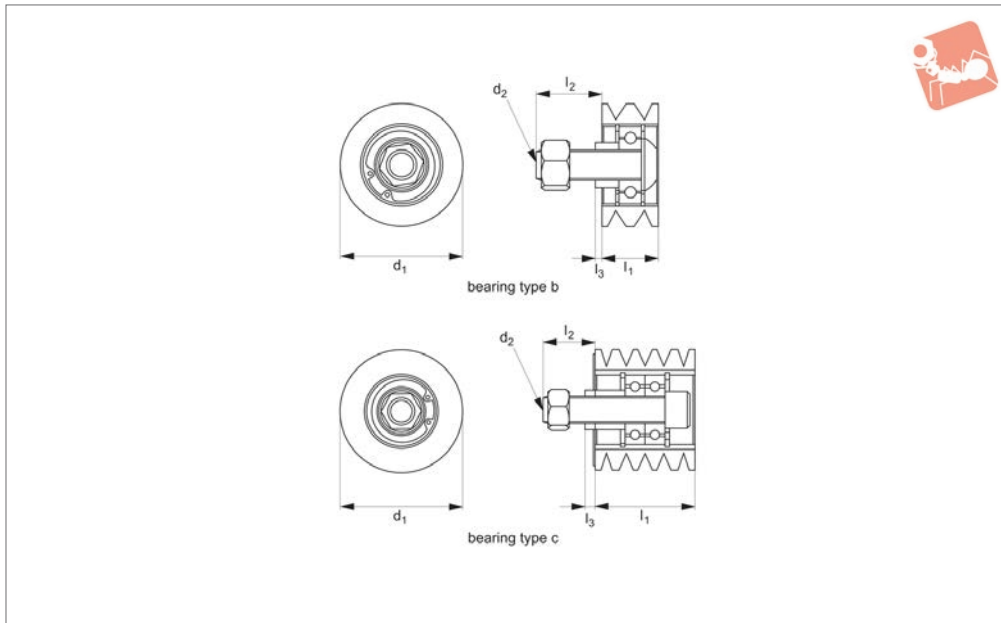

60684

ROLLERS & BUMPERS

Material

Nitrile, urethane or neoprene bonded to a steel insert. Hardness from 20-60 durometer (Shore A).

workpiece, and allowing dirt, debris and liquid to pass.
rings). For more details on bearings please see technical pages. Assembled with socket head cap screw, spacer and lock nut.

workpiece, and allowing dirt, debris and liquid to pass.

Technical Notes

Bearings included (held in place with snap

Tips

Finned rollers have grooves on the surface, creating less surface contact with the

Order No.	Material	Duro.	Bearing type	d ₁	l ₁	d ₂	l ₂	l ₃	No. of bearings	No. of fins
60684.W1002	Nitrile	20	B	50,8 (2")	23.37	41306	27.94	3.05	1	3
60684.W1003	Nitrile	35	B	50,8 (2")	23.37	41306	27.94	3.05	1	3
60684.W1006	Nitrile	60	B	50,8 (2")	23.37	41306	27.94	3.05	1	3
60684.W1012	Nitrile	20	C	50,8 (2")	49.27	41306	35.81	6.35	1	6
60684.W1013	Nitrile	35	C	50,8 (2")	49.27	41306	35.81	6.35	1	6
60684.W1016	Nitrile	60	C	50,8 (2")	49.27	41306	35.81	6.35	1	6
60684.W1022	Nitrile	20	B	63,5 (2")	49.27	41306	27.94	3.05	1	3
60684.W1023	Nitrile	35	B	50,8 (2")	49.27	41306	27.94	3.05	1	3
60684.W1026	Nitrile	60	B	50,8 (2")	49.27	41306	27.94	3.05	1	3
60684.W2003	Urethane	35	B	50,8 (2")	23.37	41306	27.94	3.05	1	3
60684.W2006	Urethane	60	B	50,8 (2")	23.37	41306	27.94	3.05	1	3
60684.W2013	Urethane	35	C	50,8 (2")	49.27	41306	35.81	6.35	1	6
60684.W2016	Urethane	60	C	50,8 (2")	49.27	41306	35.81	6.35	1	6
60684.W2023	Urethane	35	B	50,8 (2")	49.27	41306	27.94	3.05	1	3
60684.W2026	Urethane	60	B	50,8 (2")	49.27	41306	27.94	3.05	1	3
60684.W3002	Neoprene	20	B	50,8 (2")	23.37	41306	27.94	3.05	1	3
60684.W3003	Neoprene	35	B	50,8 (2")	23.37	41306	27.94	3.05	1	3
60684.W3006	Neoprene	60	B	50,8 (2")	23.37	41306	27.94	3.05	1	3
60684.W3012	Neoprene	20	C	50,8 (2")	49.27	41306	35.81	6.35	1	6
60684.W3013	Neoprene	35	C	50,8 (2")	49.27	41306	35.81	6.35	1	6
60684.W3016	Neoprene	60	C	50,8 (2")	49.27	41306	35.81	6.35	1	6
60684.W3022	Neoprene	20	B	63,5 (2")	49.27	41306	27.94	3.05	1	3
60684.W3023	Neoprene	35	B	50,8 (2")	49.27	41306	27.94	3.05	1	3
60684.W3026	Neoprene	60	B	50,8 (2")	49.27	41306	27.94	3.05	1	3

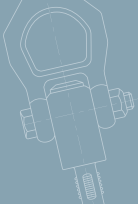

60686

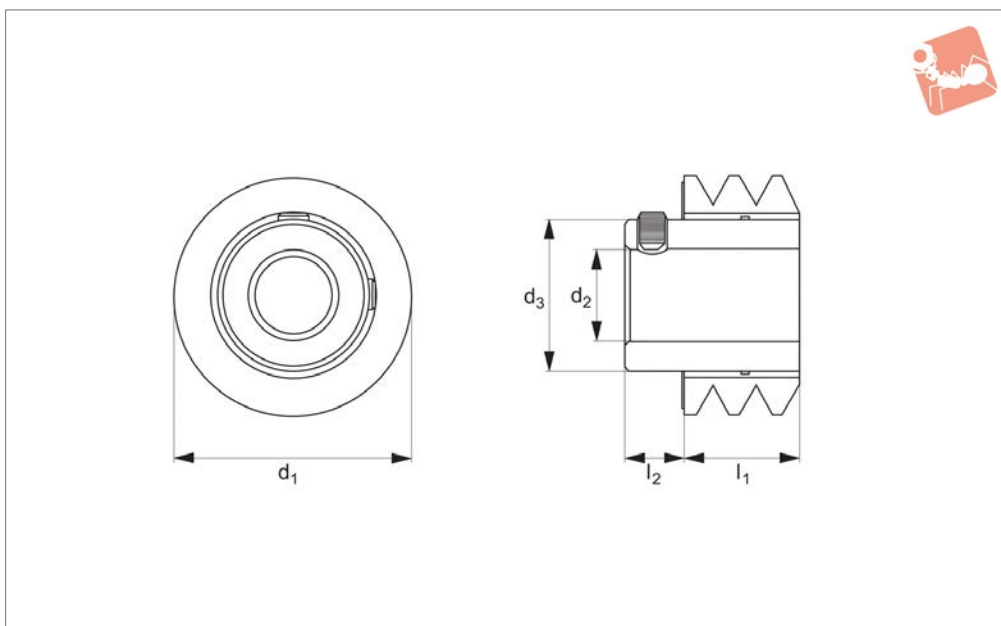

Material

Nitrile, urethane or neoprene bonded to a steel insert. Hardness from 20-60 durometer (Shore A).

Technical Notes

Designed to be mounted onto a shaft. A

hub extends past the roller and is supplied with two set screws at 90°.

liquid to pass.

Tips

Finned rollers have grooves on the surface, creating less surface contact with the workpiece, and allowing dirt, debris and

Order No.	Material	Duro.	d ₁	l ₁	d ₂ min./max.	d ₃	l ₂	No. of fins
60686.W1002	Nitrile	20	50,80 (2")	23.37	12,73/12,83	31.75	12.70	3
60686.W1003	Nitrile	35	50,80 (2")	23.37	12,73/12,83	31.75	12.70	3
60686.W1006	Nitrile	60	50,80 (2")	23.37	12,73/12,83	31.75	12.70	3
60686.W1012	Nitrile	20	50,80 (2")	23.37	15,90/16,03	31.75	12.70	3
60686.W1013	Nitrile	35	50,80 (2")	23.37	15,90/16,03	31.75	12.70	3
60686.W1016	Nitrile	60	50,80 (2")	23.37	15,90/16,03	31.75	12.70	3
60686.W1022	Nitrile	20	50,80 (2")	23.37	19,08/19,20	31.75	12.70	3
60686.W1023	Nitrile	35	50,80 (2")	23.37	19,08/19,20	31.75	12.70	3
60686.W1026	Nitrile	60	50,80 (2")	23.37	19,08/19,20	31.75	12.70	3
60686.W1032	Nitrile	20	50,80 (2")	23.27	25,43/25,55	34.80	12.70	3
60686.W1033	Nitrile	35	50,80 (2")	23.27	25,43/25,55	34.80	12.70	3
60686.W1036	Nitrile	60	50,80 (2")	23.27	25,43/25,55	34.80	12.70	3
60686.W1042	Nitrile	20	50,80 (2")	49.28	12,73/12,83	31.75	12.70	6
60686.W1043	Nitrile	35	50,80 (2")	49.28	12,73/12,83	31.75	12.70	6
60686.W1046	Nitrile	60	50,80 (2")	49.28	12,73/12,83	31.75	12.70	6
60686.W2003	Urethane	35	50,80 (2")	23.37	12,73/12,83	31.75	12.70	3
60686.W2006	Urethane	60	50,80 (2")	23.37	12,73/12,83	31.75	12.70	3
60686.W2013	Urethane	35	50,80 (2")	23.37	15,90/16,03	31.75	12.70	3
60686.W2016	Urethane	60	50,80 (2")	23.37	15,90/16,03	31.75	12.70	3
60686.W2023	Urethane	35	50,80 (2")	23.37	19,08/19,20	31.75	12.70	3
60686.W2026	Urethane	60	50,80 (2")	23.37	19,08/19,20	31.75	12.70	3
60686.W2033	Urethane	35	50,80 (2")	23.27	25,43/25,55	34.80	12.70	3
60686.W2036	Urethane	60	50,80 (2")	23.27	25,43/25,55	34.80	12.70	3
60686.W2043	Urethane	35	50,80 (2")	49.28	12,73/12,83	31.75	12.70	6
60686.W2046	Urethane	60	50,80 (2")	49.28	12,73/12,83	31.75	12.70	6
60686.W3002	Neoprene	20	50,80 (2")	23.37	12,73/12,83	31.75	12.70	3
60686.W3003	Neoprene	35	50,80 (2")	23.37	12,73/12,83	31.75	12.70	3
60686.W3006	Neoprene	60	50,80 (2")	23.37	12,73/12,83	31.75	12.70	3
60686.W3012	Neoprene	20	50,80 (2")	23.37	15,90/16,03	31.75	12.70	3
60686.W3013	Neoprene	35	50,80 (2")	23.37	15,90/16,03	31.75	12.70	3
60686.W3016	Neoprene	60	50,80 (2")	23.37	15,90/16,03	31.75	12.70	3



Finned Roller shaft drive

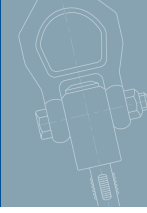

Rollers & Bumpers

Order No.	Material	Duro.	d ₁	l ₁	d ₂ min. max.	d ₃	l ₂	No. of fins
60686.W3022	Neoprene	20	50,80 (2")	23.37	19,08/19,20	31.75	12.70	3
60686.W3023	Neoprene	35	50,80 (2")	23.37	19,08/19,20	31.75	12.70	3
60686.W3026	Neoprene	60	50,80 (2")	23.37	19,08/19,20	31.75	12.70	3
60686.W3032	Neoprene	20	50,80 (2")	23.27	25,43/25,55	34.80	12.70	3
60686.W3033	Neoprene	35	50,80 (2")	23.27	25,43/25,55	34.80	12.70	3
60686.W3036	Neoprene	60	50,80 (2")	23.27	25,43/25,55	34.80	12.70	3
60686.W3042	Neoprene	20	50,80 (2")	49.28	12,73/12,83	31.75	12.70	6
60686.W3043	Neoprene	35	50,80 (2")	49.28	12,73/12,83	31.75	12.70	6
60686.W3046	Neoprene	60	50,80 (2")	49.28	12,73/12,83	31.75	12.70	6



60688

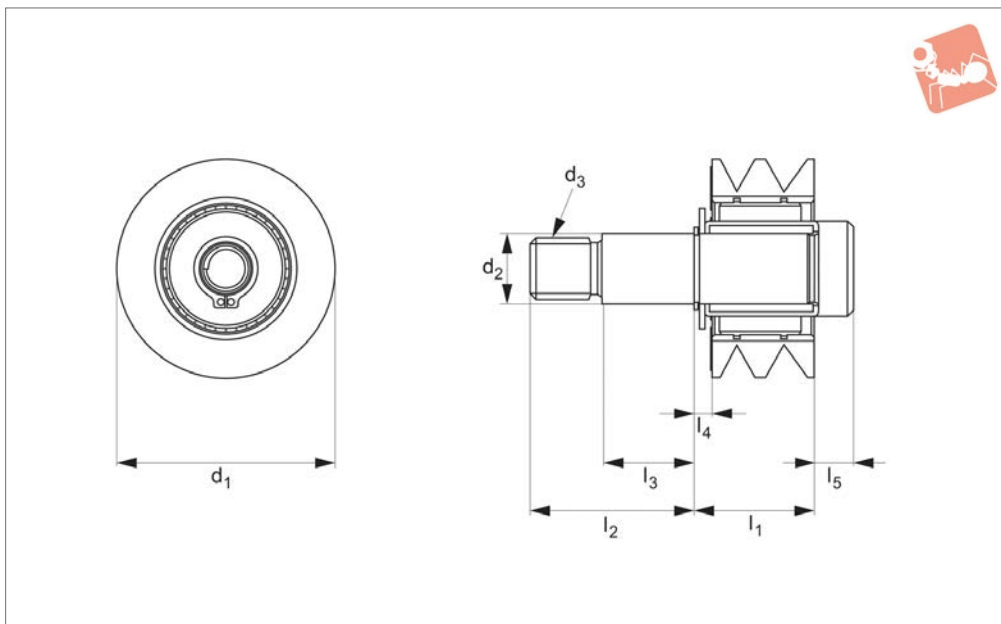

Material

Nitrile, urethane or neoprene bonded to a steel insert. Hardness from 20-60 durometer (Shore A).

Technical Notes

A clutch bearing allows the roller to turn in only one direction. Available in left or right hand rotation (with the stud pointed

upwards, a right hand rotation turns clockwise.

Type R = right hand clutch bearing.

Type L = left hand clutch bearing.

Supplied with type I bearings, please see technical page for more information on bearings.

Tips

Finned rollers have grooves on the surface, creating less surface contact with the workpiece, and allowing dirt, debris and liquid to pass.

No. of fins:

$l_1 = 23,37$ 3 fins

$l_1 = 49,28$ 6 fins

Order No.	Material	Duro.	Type	d_1	l_1	d_2 +0.05	d_3	l_2	l_3	l_4	l_5
60688.W1002	Nitrile	20	R	50.80	23.37	15.77	1/2-13"	45.47	26.42	3.05	10.41
60688.W1003	Nitrile	35	R	50.80	23.37	15.77	1/2-13"	45.47	26.42	3.05	10.41
60688.W1006	Nitrile	60	R	50.80	23.37	15.77	1/2-13"	45.47	26.42	3.05	10.41
60688.W1012	Nitrile	20	L	50.80	23.37	15.77	1/2-13"	45.47	26.42	3.05	10.41
60688.W1013	Nitrile	35	L	50.80	23.37	15.77	1/2-13"	45.47	26.42	3.05	10.41
60688.W1016	Nitrile	60	L	50.80	23.37	15.77	1/2-13"	45.47	26.42	3.05	10.41
60688.W1022	Nitrile	20	R	50.80	49.28	15.77	1/2-13"	31.75	23.62	10.42	-
60688.W1023	Nitrile	35	R	50.80	49.28	15.77	1/2-13"	31.75	23.62	10.42	-
60688.W1026	Nitrile	60	R	50.80	49.28	15.77	1/2-13"	31.75	23.62	10.42	-
60688.W1032	Nitrile	20	L	50.80	49.28	15.77	1/2-13"	31.75	23.62	10.42	-
60688.W1033	Nitrile	35	L	50.80	49.28	15.77	1/2-13"	31.75	23.62	10.42	-
60688.W1036	Nitrile	60	L	50.80	49.28	15.77	1/2-13"	31.75	23.62	10.42	-
60688.W1042	Nitrile	20	R	63.50	23.37	15.77	1/2-13"	45.47	26.42	3.05	10.42
60688.W1043	Nitrile	35	R	63.50	23.37	15.77	1/2-13"	45.47	26.42	3.05	10.42
60688.W1046	Nitrile	60	R	63.50	23.37	15.77	1/2-13"	45.47	26.42	3.05	10.42
60688.W1052	Nitrile	20	L	63.50	23.37	15.77	1/2-13"	45.47	26.42	3.05	10.42
60688.W1053	Nitrile	35	L	63.50	23.37	15.77	1/2-13"	45.47	26.42	3.05	10.42
60688.W1056	Nitrile	60	L	63,50 (2,5")	23.37	15.77	1/2-13"	45.47	26.42	3.05	10.42
60688.W2003	Urethane	35	R	50.80	23.37	15.77	1/2-13"	45.47	26.42	3.05	10.41
60688.W2006	Urethane	60	R	50.80	23.37	15.77	1/2-13"	45.47	26.42	3.05	10.41
60688.W2013	Urethane	35	L	50.80	23.37	15.77	1/2-13"	45.47	26.42	3.05	10.41
60688.W2016	Urethane	60	L	50.80	23.37	15.77	1/2-13"	45.47	26.42	3.05	10.41
60688.W2023	Urethane	35	R	50.80	49.28	15.77	1/2-13"	31.75	23.62	10.42	-
60688.W2026	Urethane	60	R	50.80	49.28	15.77	1/2-13"	31.75	23.62	10.42	-
60688.W2033	Urethane	35	L	50.80	49.28	15.77	1/2-13"	31.75	23.62	10.42	-
60688.W2036	Urethane	60	L	50.80	49.28	15.77	1/2-13"	31.75	23.62	10.42	-
60688.W2043	Urethane	35	R	63.50	23.37	15.77	1/2-13"	45.47	26.42	3.05	10.42
60688.W2046	Urethane	60	R	63.50	23.37	15.77	1/2-13"	45.47	26.42	3.05	10.42
60688.W2053	Urethane	35	L	63.50	23.37	15.77	1/2-13"	45.47	26.42	3.05	10.42



Finned Roller clutch bearing

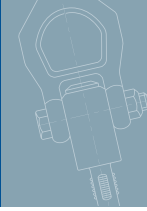

Rollers & Bumpers

Order No.	Material	Duro.	Type	d ₁	l ₁	d ₂ +0.05	d ₃	l ₂	l ₃	l ₄	l ₅
60688.W2056	Urethane	60	L	63,50 (2,5")	23.37	15.77	1/2-13"	45.47	26.42	3.05	10.42
60688.W3002	Neoprene	20	R	50.80	23.37	15.77	1/2-13"	45.47	26.42	3.05	10.41
60688.W3003	Neoprene	35	R	50.80	23.37	15.77	1/2-13"	45.47	26.42	3.05	10.41
60688.W3006	Neoprene	60	R	50.80	23.37	15.77	1/2-13"	45.47	26.42	3.05	10.41
60688.W3012	Neoprene	20	L	50.80	23.37	15.77	1/2-13"	45.47	26.42	3.05	10.41
60688.W3013	Neoprene	35	L	50.80	23.37	15.77	1/2-13"	45.47	26.42	3.05	10.41
60688.W3016	Neoprene	60	L	50.80	23.37	15.77	1/2-13"	45.47	26.42	3.05	10.41
60688.W3022	Neoprene	20	R	50.80	49.28	15.77	1/2-13"	31.75	23.62	10.42	-
60688.W3023	Neoprene	35	R	50.80	49.28	15.77	1/2-13"	31.75	23.62	10.42	-
60688.W3026	Neoprene	60	R	50.80	49.28	15.77	1/2-13"	31.75	23.62	10.42	-
60688.W3032	Neoprene	20	L	50.80	49.28	15.77	1/2-13"	31.75	23.62	10.42	-
60688.W3033	Neoprene	35	L	50.80	49.28	15.77	1/2-13"	31.75	23.62	10.42	-
60688.W3036	Neoprene	60	L	50.80	49.28	15.77	1/2-13"	31.75	23.62	10.42	-
60688.W3042	Neoprene	20	R	63.50	23.37	15.77	1/2-13"	45.47	26.42	3.05	10.42
60688.W3043	Neoprene	35	R	63.50	23.37	15.77	1/2-13"	45.47	26.42	3.05	10.42
60688.W3046	Neoprene	60	R	63.50	23.37	15.77	1/2-13"	45.47	26.42	3.05	10.42
60688.W3052	Neoprene	20	L	63.50	23.37	15.77	1/2-13"	45.47	26.42	3.05	10.42
60688.W3053	Neoprene	35	L	63.50	23.37	15.77	1/2-13"	45.47	26.42	3.05	10.42
60688.W3056	Neoprene	60	L	63.50	23.37	15.77	1/2-13"	45.47	26.42	3.05	10.42

ROLLERS & BUMPERS

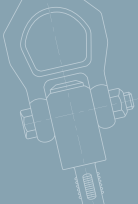

60620

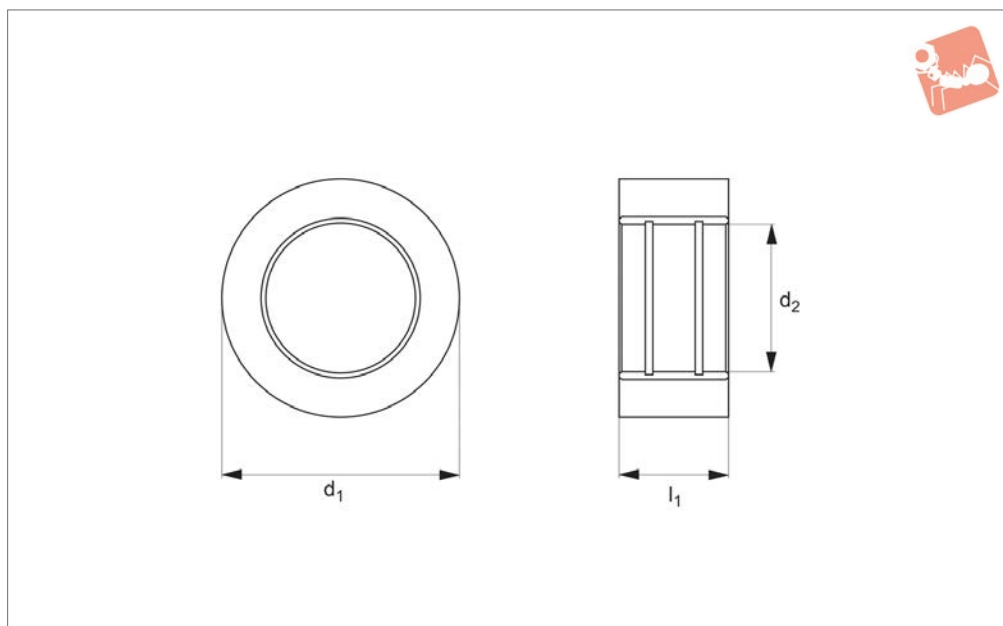

Material

Nitrile, urethane or neoprene bonded to a steel insert.

Hardness from 20-80 durometer (Shore A).

Technical Notes

Roller only - allows for custom mounting.

Order No.	Type	Durometer	d ₁	l ₁	d ₂ min. max.
60620.W1002	Nitrile	20	38,1 (1.5")	31,75 (1.25")	22,22 (7/8")
60620.W1003	Nitrile	35	38,1 (1.5")	31,75 (1.25")	22,22 (7/8")
60620.W1006	Nitrile	60	38,1 (1.5")	31,75 (1.25")	22,22 (7/8")
60620.W1008	Nitrile	80	38,1 (1.5")	31,75 (1.25")	22,22 (7/8")
60620.W1012	Nitrile	20	50,8 (2")	23,37 (0.92")	22,23 (1-1/8")
60620.W1013	Nitrile	35	50,8 (2")	23,37 (0.92")	22,23 (1-1/8")
60620.W1016	Nitrile	60	50,8 (2")	23,37 (0.92")	22,23 (1-1/8")
60620.W1018	Nitrile	80	50,8 (2")	23,37 (0.92")	22,23 (1-1/8")
60620.W1022	Nitrile	20	50,8 (2")	49,28 (1.94")	22,23 (1-1/8")
60620.W1023	Nitrile	35	50,8 (2")	49,28 (1.94")	22,23 (1-1/8")
60620.W1026	Nitrile	60	50,8 (2")	49,28 (1.94")	22,23 (1-1/8")
60620.W1028	Nitrile	80	50,8 (2")	49,28 (1.94")	22,23 (1-1/8")
60620.W1032	Nitrile	20	50,8 (2")	49,28 (1.94")	19,05 (1-1/4")
60620.W1033	Nitrile	35	50,8 (2")	49,28 (1.94")	19,05 (1-1/4")
60620.W1036	Nitrile	60	50,8 (2")	49,28 (1.94")	19,05 (1-1/4")
60620.W1038	Nitrile	80	50,8 (2")	49,28 (1.94")	19,05 (1-1/4")
60620.W1042	Nitrile	20	63,5 (2.5")	23,37 (0.92")	19,05 (1-1/4")
60620.W1043	Nitrile	35	63,5 (2.5")	23,37 (0.92")	19,05 (1-1/4")
60620.W1046	Nitrile	60	63,5 (2.5")	23,37 (0.92")	19,05 (1-1/4")
60620.W1048	Nitrile	80	63,5 (2.5")	23,37 (0.92")	19,05 (1-1/4")
60620.W1052	Nitrile	20	63,5 (2.5")	49,28 (1.94")	22,23 (1-1/8")
60620.W1053	Nitrile	35	63,5 (2.5")	49,28 (1.94")	22,23 (1-1/8")
60620.W1056	Nitrile	60	63,5 (2.5")	49,28 (1.94")	22,23 (1-1/8")
60620.W1059	Nitrile	80	63,5 (2.5")	49,28 (1.94")	22,23 (1-1/8")
60620.W1062	Nitrile	20	63,5 (2.5")	49,28 (1.94")	19,05 (1-1/4")
60620.W1063	Nitrile	35	63,5 (2.5")	49,28 (1.94")	19,05 (1-1/4")
60620.W1066	Nitrile	60	63,5 (2.5")	49,28 (1.94")	19,05 (1-1/4")
60620.W1069	Nitrile	80	63,5 (2.5")	49,28 (1.94")	19,05 (1-1/4")
60620.W1072	Nitrile	20	101,6 (4")	23,37 (0.92")	22,23 (1-1/8")
60620.W1073	Nitrile	35	101,6 (4")	23,37 (0.92")	22,23 (1-1/8")
60620.W1076	Nitrile	60	101,6 (4")	23,37 (0.92")	22,23 (1-1/8")
60620.W1079	Nitrile	80	101,6 (4")	23,37 (0.92")	22,23 (1-1/8")
60620.W1082	Nitrile	20	101,6 (4")	23,37 (0.92")	19,05 (1-1/4")
60620.W1083	Nitrile	35	101,6 (4")	23,37 (0.92")	19,05 (1-1/4")



Solid Roller roller only



Rollers & Bumpers

Order No.	Type	Durometer	d ₁	l ₁	d ₂ min./max.
60620.W1086	Nitrile	60	101,6 (4")	23,37 (0.92")	19,05 (1-1/4")
60620.W1089	Nitrile	80	101,6 (4")	23,37 (0.92")	19,05 (1-1/4")
60620.W1092	Nitrile	20	101,6 (4")	49,28 (1.94")	22,23 (1-1/8")
60620.W1093	Nitrile	35	101,6 (4")	49,28 (1.94")	22,23 (1-1/8")
60620.W1096	Nitrile	60	101,6 (4")	49,28 (1.94")	22,23 (1-1/8")
60620.W1099	Nitrile	80	101,6 (4")	49,28 (1.94")	22,23 (1-1/8")
60620.W1102	Nitrile	20	101,6 (4")	49,28 (1.94")	19,05 (1-1/4")
60620.W1103	Nitrile	35	101,6 (4")	49,28 (1.94")	19,05 (1-1/4")
60620.W1106	Nitrile	60	101,6 (4")	49,28 (1.94")	19,05 (1-1/4")
60620.W1109	Nitrile	80	101,6 (4")	49,28 (1.94")	19,05 (1-1/4")
60620.W2003	Urethane	35	38,1 (1.5")	31,75 (1.25")	22,22 (7/8")
60620.W2006	Urethane	60	38,1 (1.5")	31,75 (1.25")	22,22 (7/8")
60620.W2008	Urethane	80	38,1 (1.5")	31,75 (1.25")	22,22 (7/8")
60620.W2013	Urethane	35	50,8 (2")	23,37 (0.92")	22,23 (1-1/8")
60620.W2016	Urethane	60	50,8 (2")	23,37 (0.92")	22,23 (1-1/8")
60620.W2018	Urethane	80	50,8 (2")	23,37 (0.92")	22,23 (1-1/8")
60620.W2023	Urethane	35	50,8 (2")	49,28 (1.94")	22,23 (1-1/8")
60620.W2026	Urethane	60	50,8 (2")	49,28 (1.94")	22,23 (1-1/8")
60620.W2028	Urethane	80	50,8 (2")	49,28 (1.94")	22,23 (1-1/8")
60620.W2033	Urethane	35	50,8 (2")	49,28 (1.94")	19,05 (1-1/4")
60620.W2036	Urethane	60	50,8 (2")	49,28 (1.94")	19,05 (1-1/4")
60620.W2038	Urethane	80	50,8 (2")	49,28 (1.94")	19,05 (1-1/4")
60620.W2043	Urethane	35	63,5 (2.5")	23,37 (0.92")	19,05 (1-1/4")
60620.W2046	Urethane	60	63,5 (2.5")	23,37 (0.92")	19,05 (1-1/4")
60620.W2048	Urethane	80	63,5 (2.5")	23,37 (0.92")	19,05 (1-1/4")
60620.W2056	Urethane	80	63,5 (2.5")	49,28 (1.94")	22,23 (1-1/8")
60620.W2059	Urethane	95	63,5 (2.5")	49,28 (1.94")	22,23 (1-1/8")
60620.W2062	Urethane	35	63,5 (2.5")	49,28 (1.94")	19,05 (1-1/4")
60620.W2063	Urethane	60	63,5 (2.5")	49,28 (1.94")	19,05 (1-1/4")
60620.W2066	Urethane	80	63,5 (2.5")	49,28 (1.94")	19,05 (1-1/4")
60620.W2069	Urethane	95	63,5 (2.5")	49,28 (1.94")	19,05 (1-1/4")
60620.W2072	Urethane	35	101,6 (4")	23,37 (0.92")	22,23 (1-1/8")
60620.W2073	Urethane	60	101,6 (4")	23,37 (0.92")	22,23 (1-1/8")
60620.W2076	Urethane	80	101,6 (4")	23,37 (0.92")	22,23 (1-1/8")
60620.W2079	Urethane	95	101,6 (4")	23,37 (0.92")	22,23 (1-1/8")
60620.W2082	Urethane	35	101,6 (4")	23,37 (0.92")	19,05 (1-1/4")
60620.W2083	Urethane	60	101,6 (4")	23,37 (0.92")	19,05 (1-1/4")
60620.W2086	Urethane	80	101,6 (4")	23,37 (0.92")	19,05 (1-1/4")
60620.W2089	Urethane	95	101,6 (4")	23,37 (0.92")	19,05 (1-1/4")
60620.W2092	Urethane	35	101,6 (4")	49,28 (1.94")	22,23 (1-1/8")
60620.W2093	Urethane	60	101,6 (4")	49,28 (1.94")	22,23 (1-1/8")
60620.W2096	Urethane	80	101,6 (4")	49,28 (1.94")	22,23 (1-1/8")
60620.W2099	Urethane	95	101,6 (4")	49,28 (1.94")	22,23 (1-1/8")
60620.W2102	Urethane	35	101,6 (4")	49,28 (1.94")	19,05 (1-1/4")
60620.W2103	Urethane	60	101,6 (4")	49,28 (1.94")	19,05 (1-1/4")
60620.W2106	Urethane	80	101,6 (4")	49,28 (1.94")	19,05 (1-1/4")
60620.W2108	Urethane	95	101,6 (4")	49,28 (1.94")	19,05 (1-1/4")
60620.W2109	Urethane	60	152,4 (6")	49,28 (1.94")	22,23 (1-1/8")
60620.W2110	Urethane	60	152,4 (6")	49,28 (1.94")	19,05 (1-1/4")
60620.W2111	Urethane	80	152,4 (6")	49,28 (1.94")	22,23 (1-1/8")
60620.W2112	Urethane	80	152,4 (6")	49,28 (1.94")	19,05 (1-1/4")
60620.W2113	Urethane	35	152,4 (6")	49,28 (1.94")	22,23 (1-1/8")
60620.W2114	Urethane	35	127,0 (5")	49,28 (1.94")	22,23 (1-1/8")
60620.W2116	Urethane	60	127,0 (5")	49,28 (1.94")	22,23 (1-1/8")
60620.W2119	Urethane	80	127,0 (5")	49,28 (1.94")	22,23 (1-1/8")
60620.W2123	Urethane	35	127,0 (5")	49,28 (1.94")	19,05 (1-1/4")
60620.W2126	Urethane	60	127,0 (5")	49,28 (1.94")	19,05 (1-1/4")
60620.W2129	Urethane	80	127,0 (5")	49,28 (1.94")	19,05 (1-1/4")
60620.W2133	Urethane	35	152,4 (6")	49,28 (1.94")	19,05 (1-1/4")
60620.W3053	Urethane	35	63,5 (2.5")	49,28 (1.94")	22,23 (1-1/8")
60620.W2052	Neoprene	35	63,5 (2.5")	49,28 (1.94")	22,23 (1-1/8")
60620.W3056	Neoprene	60	63,5 (2.5")	49,28 (1.94")	22,23 (1-1/8")
60620.W3059	Neoprene	80	63,5 (2.5")	49,28 (1.94")	22,23 (1-1/8")
60620.W3062	Neoprene	20	63,5 (2.5")	49,28 (1.94")	22,23 (1-1/8")
60620.W3063	Neoprene	35	63,5 (2.5")	49,28 (1.94")	19,05 (1-1/4")
60620.W3069	Neoprene	80	63,5 (2.5")	49,28 (1.94")	19,05 (1-1/4")
60620.W2053	Neoprene	60	63,5 (2.5")	49,28 (1.94")	19,05 (1-1/4")
60620.W3002	Neoprene	20	38,1 (1.5")	31,75 (1.25")	22,22 (7/8")

ROLLERS & BUMPERS

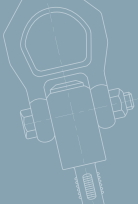

Order No.	Type	Durometer	d ₁	l ₁	d ₂ min. max.
60620.W3003	Neoprene	35	38,1 (1.5")	31,75 (1.25")	22,22 (7/8")
60620.W3006	Neoprene	60	38,1 (1.5")	31,75 (1.25")	22,22 (7/8")
60620.W3008	Neoprene	80	38,1 (1.5")	31,75 (1.25")	22,22 (7/8")
60620.W3012	Neoprene	20	50,8 (2")	23,37 (0.92")	19,05 (1-1/4")
60620.W3013	Neoprene	35	50,8 (2")	23,37 (0.92")	22,23 (1-1/8")
60620.W3016	Neoprene	60	50,8 (2")	23,37 (0.92")	22,23 (1-1/8")
60620.W3018	Neoprene	80	50,8 (2")	23,37 (0.92")	22,23 (1-1/8")
60620.W3022	Neoprene	20	50,8 (2")	49,28 (1.94")	22,23 (1-1/8")
60620.W3023	Neoprene	35	50,8 (2")	49,28 (1.94")	22,23 (1-1/8")
60620.W3026	Neoprene	60	50,8 (2")	49,28 (1.94")	22,23 (1-1/8")
60620.W3028	Neoprene	80	50,8 (2")	49,28 (1.94")	22,23 (1-1/8")
60620.W3032	Neoprene	20	50,8 (2")	49,28 (1.94")	19,05 (1-1/4")
60620.W3033	Neoprene	35	50,8 (2")	49,28 (1.94")	19,05 (1-1/4")
60620.W3036	Neoprene	60	50,8 (2")	49,28 (1.94")	19,05 (1-1/4")
60620.W3038	Neoprene	80	50,8 (2")	49,28 (1.94")	19,05 (1-1/4")
60620.W3042	Neoprene	20	63,5 (2.5")	23,37 (0.92")	19,05 (1-1/4")
60620.W3043	Neoprene	35	63,5 (2.5")	23,37 (0.92")	19,05 (1-1/4")
60620.W3046	Neoprene	60	63,5 (2.5")	23,37 (0.92")	19,05 (1-1/4")
60620.W3048	Neoprene	80	63,5 (2.5")	23,37 (0.92")	19,05 (1-1/4")
60620.W3072	Neoprene	20	101,6 (4")	23,37 (0.92")	22,23 (1-1/8")
60620.W3073	Neoprene	35	101,6 (4")	23,37 (0.92")	22,23 (1-1/8")
60620.W3076	Neoprene	60	101,6 (4")	23,37 (0.92")	22,23 (1-1/8")
60620.W3079	Neoprene	80	101,6 (4")	23,37 (0.92")	22,23 (1-1/8")
60620.W3082	Neoprene	20	101,6 (4")	23,37 (0.92")	19,05 (1-1/4")
60620.W3083	Neoprene	35	101,6 (4")	23,37 (0.92")	19,05 (1-1/4")
60620.W3086	Neoprene	60	101,6 (4")	23,37 (0.92")	19,05 (1-1/4")
60620.W3089	Neoprene	80	101,6 (4")	23,37 (0.92")	19,05 (1-1/4")
60620.W3092	Neoprene	20	101,6 (4")	49,28 (1.94")	22,23 (1-1/8")
60620.W3093	Neoprene	35	101,6 (4")	49,28 (1.94")	22,23 (1-1/8")
60620.W3096	Neoprene	60	101,6 (4")	49,28 (1.94")	22,23 (1-1/8")
60620.W3099	Neoprene	80	101,6 (4")	49,28 (1.94")	22,23 (1-1/8")
60620.W3102	Neoprene	20	101,6 (4")	49,28 (1.94")	19,05 (1-1/4")
60620.W3103	Neoprene	35	101,6 (4")	49,28 (1.94")	19,05 (1-1/4")
60620.W3106	Neoprene	60	101,6 (4")	49,28 (1.94")	19,05 (1-1/4")
60620.W3109	Neoprene	80	101,6 (4")	49,28 (1.94")	19,05 (1-1/4")

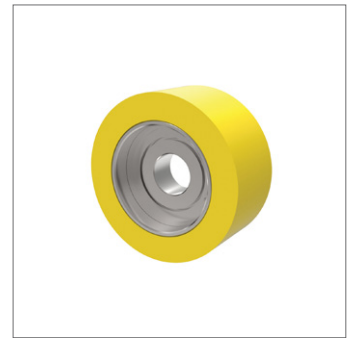
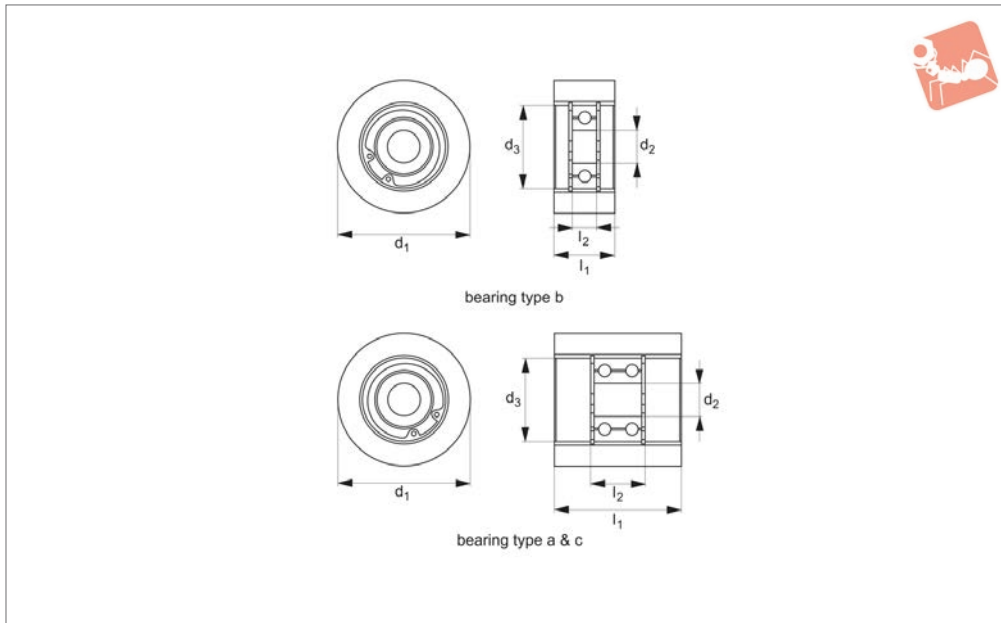

60622

ROLLERS & BUMPERS

Material

Nitrile, urethane or neoprene bonded to a steel insert.
Hardness from 20-80 durometer (Shore A).

Technical Notes

Bearings included (held in place with snap rings). For more details on bearings please

see technical pages.

Tolerances:
When $d_1=38,10$
 $d_2 \pm 0.05$
 $d_3 \pm 0.07$
 $l_2 \pm 0.05$

When $d_1 > 38,10$
 $d_2 \pm 0,065$
 $d_3 \pm 0,065$
 $l_2 \pm 0,08$

Order No.	Material	Durometer	d_1	l_1	d_2	d_3	l_2	Bearing type
60622.W1002	Nitrile	20	38,1 (1,5")	31.75	8.0	22.16	12.70	A
60622.W1003	Nitrile	35	38,1 (1,5")	31.75	8.0	22.16	12.70	A
60622.W1006	Nitrile	60	38,1 (1,5")	31.75	8.0	22.16	12.70	A
60622.W1008	Nitrile	80	38,1 (1,5")	31.75	8.0	22.16	12.70	A
60622.W1012	Nitrile	20	50,8 (2,0")	23.37	12.77	31.69	9.52	B
60622.W1013	Nitrile	35	50,8 (2,0")	23.37	12.77	31.69	9.52	B
60622.W1016	Nitrile	60	50,8 (2,0")	23.37	12.77	31.69	9.52	B
60622.W1018	Nitrile	80	50,8 (2,0")	23.37	12.77	31.69	9.52	B
60622.W1022	Nitrile	20	50,8 (2,0")	49.28	12.77	31.69	19.05	C
60622.W1023	Nitrile	35	50,8 (2,0")	49.28	12.77	31.69	19.05	C
60622.W1026	Nitrile	60	50,8 (2,0")	49.28	12.77	31.69	19.05	C
60622.W1028	Nitrile	80	50,8 (2,0")	49.28	12.77	31.69	19.05	C
60622.W1032	Nitrile	20	63,5 (2,5")	23.37	12.77	31.69	9.52	C
60622.W1033	Nitrile	35	63,5 (2,5")	23.37	12.77	31.69	9.52	C
60622.W1036	Nitrile	60	63,5 (2,5")	23.37	12.77	31.69	9.52	C
60622.W1038	Nitrile	80	63,5 (2,5")	23.37	12.77	31.69	9.52	C
60622.W1042	Nitrile	20	63,5 (2,5")	49.28	12.77	31.69	19.05	C
60622.W1043	Nitrile	35	63,5 (2,5")	49.28	12.77	31.69	19.05	C
60622.W1046	Nitrile	60	63,5 (2,5")	49.28	12.77	31.69	19.05	C
60622.W1048	Nitrile	80	63,5 (2,5")	49.28	12.77	31.69	19.05	C
60622.W1052	Nitrile	20	101,6 (4,0")	23.37	12.77	31.69	9.52	B
60622.W1053	Nitrile	35	101,6 (4,0")	23.37	12.77	31.69	9.52	B
60622.W1056	Nitrile	60	101,6 (4,0")	23.37	12.77	31.69	9.52	B
60622.W1058	Nitrile	80	101,6 (4,0")	23.37	12.77	31.69	9.52	B
60622.W1062	Nitrile	20	101,6 (4,0")	49.28	12.77	31.69	19.05	C
60622.W1063	Nitrile	35	101,6 (4,0")	49.28	12.77	31.69	19.05	C
60622.W1066	Nitrile	60	101,6 (4,0")	49.28	12.77	31.69	19.05	C
60622.W1068	Nitrile	80	101,6 (4,0")	49.28	12.77	31.69	19.05	C
60622.W2003	Urethane	35	38,1 (1,5")	31.75	8.0	22.16	12.70	A
60622.W2006	Urethane	60	38,1 (1,5")	31.75	8.0	22.16	12.70	A
60622.W2008	Urethane	80	38,1 (1,5")	31.75	8.0	22.16	12.70	A

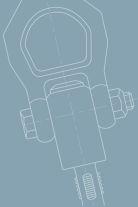

Order No.	Material	Durometer	d ₁	l ₁	d ₂	d ₃	l ₂	Bearing type
60622.W2013	Urethane	35	50,8 (2,0")	23.37	12.77	31.69	9.52	B
60622.W2016	Urethane	60	50,8 (2,0")	23.37	12.77	31.69	9.52	B
60622.W2018	Urethane	80	50,8 (2,0")	23.37	12.77	31.69	9.52	B
60622.W2023	Urethane	35	50,8 (2,0")	49.28	12.77	31.69	19.05	C
60622.W2026	Urethane	60	50,8 (2,0")	49.28	12.77	31.69	19.05	C
60622.W2028	Urethane	80	50,8 (2,0")	49.28	12.77	31.69	19.05	C
60622.W2033	Urethane	35	63,5 (2,5")	23.37	12.77	31.69	9.52	C
60622.W2036	Urethane	60	63,5 (2,5")	23.37	12.77	31.69	9.52	C
60622.W2038	Urethane	80	63,5 (2,5")	23.37	12.77	31.69	9.52	C
60622.W2043	Urethane	35	63,5 (2,5")	49.28	12.77	31.69	19.05	C
60622.W2046	Urethane	60	63,5 (2,5")	49.28	12.77	31.69	19.05	C
60622.W2048	Urethane	80	63,5 (2,5")	49.28	12.77	31.69	19.05	C
60622.W2053	Urethane	35	101,6 (4,0")	23.37	12.77	31.69	9.52	B
60622.W2056	Urethane	60	101,6 (4,0")	23.37	12.77	31.69	9.52	B
60622.W2058	Urethane	80	101,6 (4,0")	23.37	12.77	31.69	9.52	B
60622.W2063	Urethane	35	101,6 (4,0")	49.28	12.77	31.69	19.05	C
60622.W2066	Urethane	60	101,6 (4,0")	49.28	12.77	31.69	19.05	C
60622.W2068	Urethane	80	101,6 (4,0")	49.28	12.77	31.69	19.05	C
60622.W2073	Urethane	35	127,0 (5,0")	49.28	12.77	31.69	19.05	C
60622.W2076	Urethane	60	127,0 (5,0")	49.28	12.77	31.69	19.05	C
60622.W2083	Urethane	35	152,4 (6,0")	49.28	12.77	31.69	19.05	C
60622.W2086	Urethane	60	152,4 (6,0")	49.28	12.77	31.69	19.05	C
60622.W2088	Urethane	80	152,4 (6,0")	49.28	12.77	31.69	19.05	C
60622.W3002	Neoprene	20	38,1 (1,5")	31.75	8.0	22.16	12.70	A
60622.W3003	Neoprene	35	38,1 (1,5")	31.75	8.0	22.16	12.70	A
60622.W3006	Neoprene	60	38,1 (1,5")	31.75	8.0	22.16	12.70	A
60622.W3008	Neoprene	80	38,1 (1,5")	31.75	8.0	22.16	12.70	A
60622.W3012	Neoprene	20	50,8 (2,0")	23.37	12.77	31.69	9.52	B
60622.W3013	Neoprene	35	50,8 (2,0")	23.37	12.77	31.69	9.52	B
60622.W3016	Neoprene	60	50,8 (2,0")	23.37	12.77	31.69	9.52	B
60622.W3018	Neoprene	80	50,8 (2,0")	23.37	12.77	31.69	9.52	B
60622.W3022	Neoprene	20	50,8 (2,0")	49.28	12.77	31.69	19.05	C
60622.W3023	Neoprene	35	50,8 (2,0")	49.28	12.77	31.69	19.05	C
60622.W3026	Neoprene	60	50,8 (2,0")	49.28	12.77	31.69	19.05	C
60622.W3028	Neoprene	80	50,8 (2,0")	49.28	12.77	31.69	19.05	C
60622.W3032	Neoprene	20	63,5 (2,5")	23.37	12.77	31.69	9.52	C
60622.W3033	Neoprene	35	63,5 (2,5")	23.37	12.77	31.69	9.52	C
60622.W3036	Neoprene	60	63,5 (2,5")	23.37	12.77	31.69	9.52	C
60622.W3038	Neoprene	80	63,5 (2,5")	23.37	12.77	31.69	9.52	C
60622.W3042	Neoprene	20	63,5 (2,5")	49.28	12.77	31.69	19.05	C
60622.W3043	Neoprene	35	63,5 (2,5")	49.28	12.77	31.69	19.05	C
60622.W3046	Neoprene	60	63,5 (2,5")	49.28	12.77	31.69	19.05	C
60622.W3048	Neoprene	80	63,5 (2,5")	49.28	12.77	31.69	19.05	C
60622.W3052	Neoprene	20	101,6 (4,0")	23.37	12.77	31.69	9.52	B
60622.W3053	Neoprene	35	101,6 (4,0")	23.37	12.77	31.69	9.52	B
60622.W3056	Neoprene	60	101,6 (4,0")	23.37	12.77	31.69	9.52	B
60622.W3058	Neoprene	80	101,6 (4,0")	23.37	12.77	31.69	9.52	B
60622.W3062	Neoprene	20	101,6 (4,0")	49.28	12.77	31.69	19.05	C
60622.W3063	Neoprene	35	101,6 (4,0")	49.28	12.77	31.69	19.05	C
60622.W3066	Neoprene	60	101,6 (4,0")	49.28	12.77	31.69	19.05	C
60622.W3068	Neoprene	80	101,6 (4,0")	49.28	12.77	31.69	19.05	C

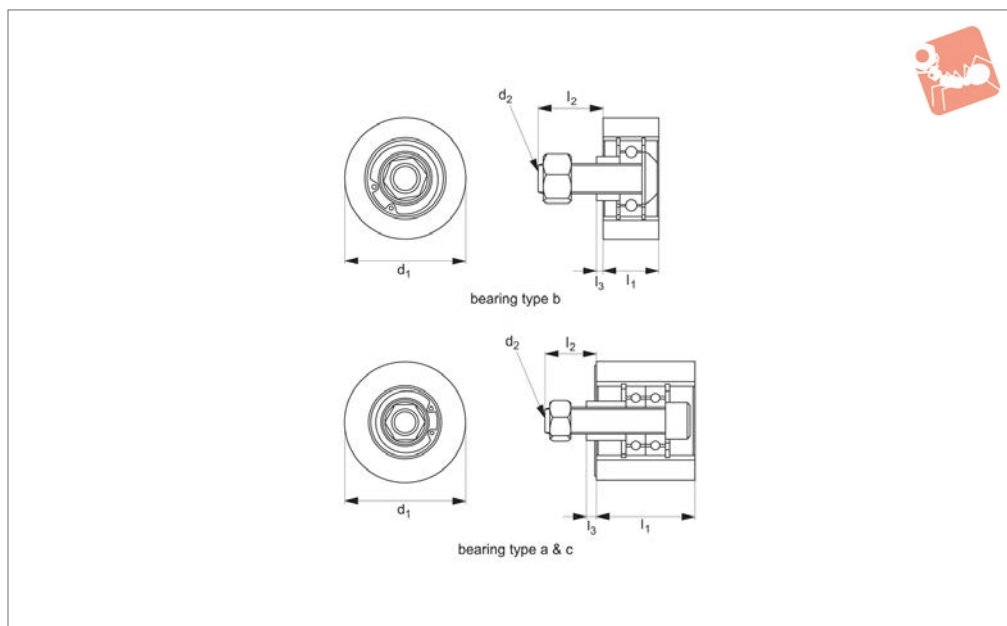
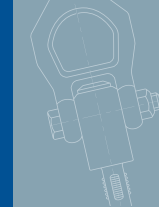

60624

ROLLERS & BUMPERS

Material

Nitrile, urethane or neoprene bonded to a steel insert.
Hardness from 20-80 durometer (Shore A).

Technical Notes

Bearings included (held in place with snap rings). For more details on bearings please see technical pages. Assembled with socket

head cap screw, spacer and lock nut.

Order No.	Material	Durometer	d ₁	l ₁	d ₂	l ₂	l ₃	Bearing type
60624.W1002	Nitrile	20	38,1 (1,5")	31.80	5/16-18"	16.00	3.05	A
60624.W1003	Nitrile	35	38,1 (1,5")	31.80	5/16-18"	16.00	3.05	A
60624.W1006	Nitrile	60	38,1 (1,5")	31.80	5/16-18"	16.00	3.05	A
60624.W1008	Nitrile	80	38,1 (1,5")	31.80	5/16-18"	16.00	3.05	A
60624.W1012	Nitrile	20	50,8 (2,0")	23.37	1/2-13"	27.94	3.05	B
60624.W1013	Nitrile	35	50,8 (2,0")	23.37	1/2-13"	27.94	3.05	B
60624.W1016	Nitrile	60	50,8 (2,0")	23.37	1/2-13"	27.94	3.05	B
60624.W1018	Nitrile	80	50,8 (2,0")	23.37	1/2-13"	27.94	3.05	B
60624.W1022	Nitrile	20	50,8 (2,0")	49.28	1/2-13"	35.81	6.35	C
60624.W1023	Nitrile	35	50,8 (2,0")	49.28	1/2-13"	35.81	6.35	C
60624.W1026	Nitrile	60	50,8 (2,0")	49.28	1/2-13"	35.81	6.35	C
60624.W1028	Nitrile	80	50,8 (2,0")	49.28	1/2-13"	35.81	6.35	C
60624.W1032	Nitrile	20	63,5 (2,5")	23.37	1/2-13"	27.94	3.05	B
60624.W1033	Nitrile	35	63,5 (2,5")	23.37	1/2-13"	27.94	3.05	B
60624.W1036	Nitrile	60	63,5 (2,5")	23.37	1/2-13"	27.94	3.05	B
60624.W1038	Nitrile	80	63,5 (2,5")	23.37	1/2-13"	27.94	3.05	B
60624.W1042	Nitrile	20	63,5 (2,5")	49.28	1/2-13"	35.81	6.35	C
60624.W1043	Nitrile	35	63,5 (2,5")	49.28	1/2-13"	35.81	6.35	C
60624.W1046	Nitrile	60	63,5 (2,5")	49.28	1/2-13"	35.81	6.35	C
60624.W1048	Nitrile	80	63,5 (2,5")	49.28	1/2-13"	35.81	6.35	C
60624.W1052	Nitrile	20	101,6 (4,0")	23.37	1/2-13"	27.94	3.05	B
60624.W1053	Nitrile	35	101,6 (4,0")	23.37	1/2-13"	27.94	3.05	B
60624.W1056	Nitrile	60	101,6 (4,0")	23.37	1/2-13"	27.94	3.05	B
60624.W1058	Nitrile	80	101,6 (4,0")	23.37	1/2-13"	27.94	3.05	B
60624.W1062	Nitrile	20	101,6 (4,0")	49.28	1/2-13"	35.56	6.35	C
60624.W1063	Nitrile	35	101,6 (4,0")	49.28	1/2-13"	35.56	6.35	C
60624.W1066	Nitrile	60	101,6 (4,0")	49.28	1/2-13"	35.56	6.35	C
60624.W1068	Nitrile	60	101,6 (4,0")	49.28	1/2-13"	35.56	6.35	C
60624.W2003	Urethane	35	38,1 (1,5")	31.80	5/16-18"	16.00	3.05	A
60624.W2006	Urethane	60	38,1 (1,5")	31.80	5/16-18"	16.00	3.05	A
60624.W2008	Urethane	80	38,1 (1,5")	31.80	5/16-18"	16.00	3.05	A
60624.W2013	Urethane	35	50,8 (2,0")	23.37	1/2-13"	27.94	3.05	B
60624.W2016	Urethane	60	50,8 (2,0")	23.37	1/2-13"	27.94	3.05	B
60624.W2018	Urethane	80	50,8 (2,0")	23.37	1/2-13"	27.94	3.05	B
60624.W2023	Urethane	35	50,8 (2,0")	49.28	1/2-13"	35.81	6.35	C

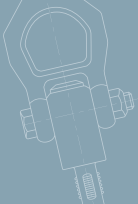

Order No.	Material	Durometer	d ₁	l ₁	d ₂	l ₂	l ₃	Bearing type
60624.W2026	Urethane	60	50,8 (2,0")	49,28	1/2-13"	35,81	6,35	C
60624.W2028	Urethane	80	50,8 (2,0")	49,28	1/2-13"	35,81	6,35	C
60624.W2033	Urethane	35	63,5 (2,5")	23,37	1/2-13"	27,94	3,05	B
60624.W2036	Urethane	60	63,5 (2,5")	23,37	1/2-13"	27,94	3,05	B
60624.W2038	Urethane	80	63,5 (2,5")	23,37	1/2-13"	27,94	3,05	B
60624.W2043	Urethane	35	63,5 (2,5")	49,28	1/2-13"	35,81	6,35	C
60624.W2046	Urethane	60	63,5 (2,5")	49,28	1/2-13"	35,81	6,35	C
60624.W2048	Urethane	80	63,5 (2,5")	49,28	1/2-13"	35,81	6,35	C
60624.W2053	Urethane	35	101,6 (4,0")	23,37	1/2-13"	27,94	3,05	B
60624.W2056	Urethane	60	101,6 (4,0")	23,37	1/2-13"	27,94	3,05	B
60624.W2058	Urethane	80	101,6 (4,0")	23,37	1/2-13"	27,94	3,05	B
60624.W2063	Urethane	35	101,6 (4,0")	49,28	1/2-13"	35,56	6,35	C
60624.W2066	Urethane	60	101,6 (4,0")	49,28	1/2-13"	35,56	6,35	C
60624.W2068	Urethane	60	101,6 (4,0")	49,28	1/2-13"	35,56	6,35	C
60624.W2073	Urethane	35	127,0 (5,0")	49,28	1/2-13"	35,56	6,35	C
60624.W2076	Urethane	60	127,0 (5,0")	49,28	1/2-13"	35,56	6,35	C
60624.W2078	Urethane	80	127,0 (5,0")	49,28	1/2-13"	35,56	6,35	C
60624.W2083	Urethane	35	152,4 (6,0")	49,28	1/2-13"	35,56	6,35	C
60624.W2086	Urethane	60	152,4 (6,0")	49,28	1/2-13"	35,56	6,35	C
60624.W2088	Urethane	80	152,4 (6,0")	49,28	1/2-13"	35,56	6,35	C
60624.W3002	Neoprene	20	38,1 (1,5")	31,80	5/16-18"	16,00	3,05	A
60624.W3003	Neoprene	35	38,1 (1,5")	31,80	5/16-18"	16,00	3,05	A
60624.W3006	Neoprene	60	38,1 (1,5")	31,80	5/16-18"	16,00	3,05	A
60624.W3008	Neoprene	80	38,1 (1,5")	31,80	5/16-18"	16,00	3,05	A
60624.W3012	Neoprene	20	50,8 (2,0")	23,37	1/2-13"	27,94	3,05	B
60624.W3013	Neoprene	35	50,8 (2,0")	23,37	1/2-13"	27,94	3,05	B
60624.W3016	Neoprene	60	50,8 (2,0")	23,37	1/2-13"	27,94	3,05	B
60624.W3018	Neoprene	80	50,8 (2,0")	23,37	1/2-13"	27,94	3,05	B
60624.W3022	Neoprene	20	50,8 (2,0")	49,28	1/2-13"	35,81	6,35	C
60624.W3023	Neoprene	35	50,8 (2,0")	49,28	1/2-13"	35,81	6,35	C
60624.W3026	Neoprene	60	50,8 (2,0")	49,28	1/2-13"	35,81	6,35	C
60624.W3028	Neoprene	80	50,8 (2,0")	49,28	1/2-13"	35,81	6,35	C
60624.W3032	Neoprene	20	63,5 (2,5")	23,37	1/2-13"	27,94	3,05	B
60624.W3033	Neoprene	35	63,5 (2,5")	23,37	1/2-13"	27,94	3,05	B
60624.W3036	Neoprene	60	63,5 (2,5")	23,37	1/2-13"	27,94	3,05	B
60624.W3038	Neoprene	80	63,5 (2,5")	23,37	1/2-13"	27,94	3,05	B
60624.W3042	Neoprene	20	63,5 (2,5")	49,28	1/2-13"	35,81	6,35	C
60624.W3043	Neoprene	35	63,5 (2,5")	49,28	1/2-13"	35,81	6,35	C
60624.W3046	Neoprene	60	63,5 (2,5")	49,28	1/2-13"	35,81	6,35	C
60624.W3048	Neoprene	80	63,5 (2,5")	49,28	1/2-13"	35,81	6,35	C
60624.W3052	Neoprene	20	101,6 (4,0")	23,37	1/2-13"	27,94	3,05	B
60624.W3053	Neoprene	35	101,6 (4,0")	23,37	1/2-13"	27,94	3,05	B
60624.W3056	Neoprene	60	101,6 (4,0")	23,37	1/2-13"	27,94	3,05	B
60624.W3058	Neoprene	80	101,6 (4,0")	23,37	1/2-13"	27,94	3,05	B
60624.W3062	Neoprene	20	101,6 (4,0")	49,28	1/2-13"	35,56	6,35	C
60624.W3063	Neoprene	35	101,6 (4,0")	49,28	1/2-13"	35,56	6,35	C
60624.W3066	Neoprene	60	101,6 (4,0")	49,28	1/2-13"	35,56	6,35	C
60624.W3068	Neoprene	60	101,6 (4,0")	49,28	1/2-13"	35,56	6,35	C

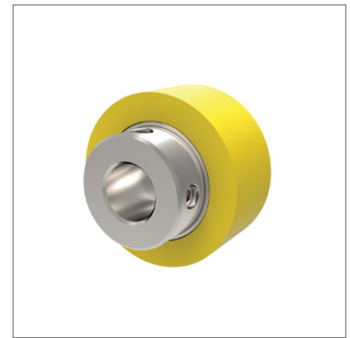
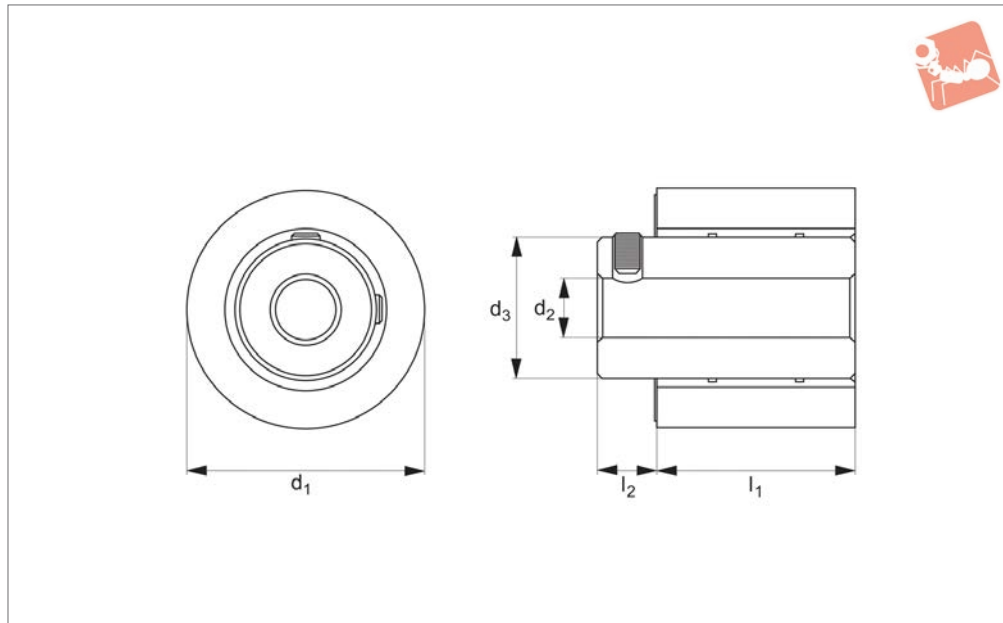
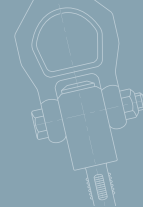

60626

ROLLERS & BUMPERS

Material

Nitrile, urethane or neoprene bonded to a steel insert.

Hardness from 20-80 durometer (Shore A).

Technical Notes

Designed to be mounted onto a shaft. A

hub extends past the roller and is supplied with two set screws at 90°.

Order No.	Material	Durometer	d ₁	l ₁	d ₂	d ₃	l ₂
60626.W1002	Nitrile	20	38,10 (1,5")	22.36	31.75	12,72/12,83	9.65
60626.W1003	Nitrile	35	38,10 (1,5")	22.36	31.75	12,72/12,83	9.65
60626.W1006	Nitrile	60	38,10 (1,5")	22.36	31.75	12,72/12,83	9.65
60626.W1008	Nitrile	80	38,10 (1,5")	22.36	31.75	12,72/12,83	9.65
60626.W1012	Nitrile	20	50,80 (2,0")	31.75	23.37	12,72/12,83	12.70
60626.W1013	Nitrile	35	50,80 (2,0")	31.75	23.37	12,72/12,83	12.70
60626.W1016	Nitrile	60	50,80 (2,0")	31.75	23.37	12,72/12,83	12.70
60626.W1018	Nitrile	80	50,80 (2,0")	31.75	23.37	12,72/12,83	12.70
60626.W1022	Nitrile	20	50,80 (2,0")	31.75	23.37	19,08/19,20	12.70
60626.W1023	Nitrile	35	50,80 (2,0")	31.75	23.37	19,08/19,20	12.70
60626.W1026	Nitrile	60	50,80 (2,0")	31.75	23.37	19,08/19,20	12.70
60626.W1028	Nitrile	80	50,80 (2,0")	31.75	23.37	19,08/19,20	12.70
60626.W1032	Nitrile	20	50,80 (2,0")	31.75	49.28	12,73/12,83	12.70
60626.W1033	Nitrile	35	50,80 (2,0")	31.75	49.28	12,73/12,83	12.70
60626.W1036	Nitrile	60	50,80 (2,0")	31.75	49.28	12,73/12,83	12.70
60626.W1038	Nitrile	80	50,80 (2,0")	31.75	49.28	12,73/12,83	12.70
60626.W1042	Nitrile	20	50,80 (2,0")	31.75	49.28	19,08/19,20	12.70
60626.W1043	Nitrile	35	50,80 (2,0")	31.75	49.28	19,08/19,20	12.70
60626.W1046	Nitrile	60	50,80 (2,0")	31.75	49.28	19,08/19,20	12.70
60626.W1048	Nitrile	80	50,80 (2,0")	31.75	49.28	19,08/19,20	12.70
60626.W1052	Nitrile	20	63,50 (2,5")	31.75	23.37	12,73/12,83	12.70
60626.W1053	Nitrile	35	63,50 (2,5")	31.75	23.37	12,73/12,83	12.70
60626.W1056	Nitrile	60	63,50 (2,5")	31.75	23.37	12,73/12,83	12.70
60626.W1058	Nitrile	80	63,50 (2,5")	31.75	23.37	12,73/12,83	12.70
60626.W1062	Nitrile	20	63,50 (2,5")	34.79	23.37	19,08/19,20	12.70
60626.W1063	Nitrile	35	63,50 (2,5")	34.79	23.37	19,08/19,20	12.70
60626.W1066	Nitrile	60	63,50 (2,5")	34.79	23.37	19,08/19,20	12.70
60626.W1068	Nitrile	80	63,50 (2,5")	34.79	23.37	19,08/19,20	12.70
60626.W1072	Nitrile	20	63,50 (2,5")	31.75	49.28	12,73/12,83	12.70
60626.W1073	Nitrile	35	63,50 (2,5")	31.75	49.28	12,73/12,83	12.70
60626.W1076	Nitrile	60	63,50 (2,5")	31.75	49.28	12,73/12,83	12.70
60626.W1078	Nitrile	80	63,50 (2,5")	31.75	49.28	12,73/12,83	12.70
60626.W1082	Nitrile	20	63,50 (2,5")	31.75	49.28	19,08/19,20	12.70
60626.W1083	Nitrile	35	63,50 (2,5")	31.75	49.28	19,08/19,20	12.70
60626.W1086	Nitrile	60	63,50 (2,5")	31.75	49.28	19,08/19,20	12.70

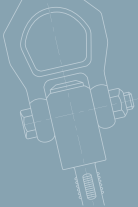

Order No.	Material	Durometer	d ₁	l ₁	d ₂	d ₃	l ₂
60626.W1088	Nitrile	80	63,50 (2,5")	31.75	49.28	19,08/19,20	12.70
60626.W1092	Nitrile	20	63,50 (2,5")	34.79	49.28	25,42/25,55	12.70
60626.W1093	Nitrile	35	63,50 (2,5")	34.79	49.28	25,42/25,55	12.70
60626.W1096	Nitrile	60	63,50 (2,5")	34.79	49.28	25,42/25,55	12.70
60626.W1098	Nitrile	80	63,50 (2,5")	34.79	49.28	25,42/25,55	12.70
60626.W1102	Nitrile	20	101,6 (4,0")	31.75	23.37	12,73/12,83	12.70
60626.W1103	Nitrile	35	101,6 (4,0")	31.75	23.37	12,73/12,83	12.70
60626.W1106	Nitrile	60	101,6 (4,0")	31.75	23.37	12,73/12,83	12.70
60626.W1108	Nitrile	80	101,6 (4,0")	31.75	23.37	12,73/12,83	12.70
60626.W1112	Nitrile	20	101,6 (4,0")	31.75	23.37	19,08/19,20	12.70
60626.W1113	Nitrile	35	101,6 (4,0")	31.75	23.37	19,08/19,20	12.70
60626.W1116	Nitrile	60	101,6 (4,0")	31.75	23.37	19,08/19,20	12.70
60626.W1118	Nitrile	80	101,6 (4,0")	31.75	23.37	19,08/19,20	12.70
60626.W1122	Nitrile	20	101,6 (4,0")	31.75	49.28	12,73/12,83	12.70
60626.W1123	Nitrile	35	101,6 (4,0")	31.75	49.28	12,73/12,83	12.70
60626.W1126	Nitrile	60	101,6 (4,0")	31.75	49.28	12,73/12,83	12.70
60626.W1128	Nitrile	80	101,6 (4,0")	31.75	49.28	12,73/12,83	12.70
60626.W1132	Nitrile	20	101,6 (4,0")	31.75	49.28	19,08/19,20	12.70
60626.W1133	Nitrile	35	101,6 (4,0")	31.75	49.28	19,08/19,20	12.70
60626.W1136	Nitrile	60	101,6 (4,0")	31.75	49.28	19,08/19,20	12.70
60626.W1138	Nitrile	80	101,6 (4,0")	31.75	49.28	19,08/19,20	12.70
60626.W1146	Nitrile	60	101,6 (4,0")	34.80	49.28	31,78/31,90	12.70
60626.W2003	Urethane	35	38,10 (1,5")	22.36	31.75	12,72/12,83	9.65
60626.W2006	Urethane	60	38,10 (1,5")	22.36	31.75	12,72/12,83	9.65
60626.W2008	Urethane	80	38,10 (1,5")	22.36	31.75	12,72/12,83	9.65
60626.W2013	Urethane	35	50,80 (2,0")	31.75	23.37	12,72/12,83	12.70
60626.W2016	Urethane	60	50,80 (2,0")	31.75	23.37	12,72/12,83	12.70
60626.W2018	Urethane	80	50,80 (2,0")	31.75	23.37	12,72/12,83	12.70
60626.W2023	Urethane	35	50,80 (2,0")	31.75	23.37	19,08/19,20	12.70
60626.W2026	Urethane	60	50,80 (2,0")	31.75	23.37	19,08/19,20	12.70
60626.W2028	Urethane	80	50,80 (2,0")	31.75	23.37	19,08/19,20	12.70
60626.W2033	Urethane	35	50,80 (2,0")	31.75	49.28	12,73/12,83	12.70
60626.W2036	Urethane	60	50,80 (2,0")	31.75	49.28	12,73/12,83	12.70
60626.W2038	Urethane	80	50,80 (2,0")	31.75	49.28	12,73/12,83	12.70
60626.W2043	Urethane	35	50,80 (2,0")	31.75	49.28	19,08/19,20	12.70
60626.W2046	Urethane	60	50,80 (2,0")	31.75	49.28	19,08/19,20	12.70
60626.W2048	Urethane	80	50,80 (2,0")	31.75	49.28	19,08/19,20	12.70
60626.W2053	Urethane	35	63,50 (2,5")	31.75	23.37	12,73/12,83	12.70
60626.W2056	Urethane	60	63,50 (2,5")	31.75	23.37	12,73/12,83	12.70
60626.W2058	Urethane	80	63,50 (2,5")	31.75	23.37	12,73/12,83	12.70
60626.W2063	Urethane	35	63,50 (2,5")	34.79	23.37	19,08/19,20	12.70
60626.W2066	Urethane	60	63,50 (2,5")	34.79	23.37	19,08/19,20	12.70
60626.W2068	Urethane	80	63,50 (2,5")	34.79	23.37	19,08/19,20	12.70
60626.W2073	Urethane	35	63,50 (2,5")	31.75	49.28	12,73/12,83	12.70
60626.W2076	Urethane	60	63,50 (2,5")	31.75	49.28	12,73/12,83	12.70
60626.W2078	Urethane	80	63,50 (2,5")	31.75	49.28	12,73/12,83	12.70
60626.W2083	Urethane	35	63,50 (2,5")	31.75	49.28	19,08/19,20	12.70
60626.W2086	Urethane	60	63,50 (2,5")	31.75	49.28	19,08/19,20	12.70
60626.W2088	Urethane	80	63,50 (2,5")	31.75	49.28	19,08/19,20	12.70
60626.W2093	Urethane	35	63,50 (2,5")	34.79	49.28	25,42/25,55	12.70
60626.W2096	Urethane	60	63,50 (2,5")	34.79	49.28	25,42/25,55	12.70
60626.W2098	Urethane	80	63,50 (2,5")	34.79	49.28	25,42/25,55	12.70
60626.W2103	Urethane	35	101,6 (4,0")	31.75	23.37	12,73/12,83	12.70
60626.W2106	Urethane	60	101,6 (4,0")	31.75	23.37	12,73/12,83	12.70
60626.W2108	Urethane	80	101,6 (4,0")	31.75	23.37	12,73/12,83	12.70
60626.W2116	Urethane	60	101,6 (4,0")	31.75	23.37	19,08/19,20	12.70
60626.W2118	Urethane	80	101,6 (4,0")	31.75	23.37	19,08/19,20	12.70
60626.W2123	Urethane	35	101,6 (4,0")	31.75	49.28	12,73/12,83	12.70
60626.W2126	Urethane	60	101,6 (4,0")	31.75	49.28	12,73/12,83	12.70
60626.W2128	Urethane	80	101,6 (4,0")	31.75	49.28	12,73/12,83	12.70
60626.W2133	Urethane	35	101,6 (4,0")	31.75	49.28	19,08/19,20	12.70
60626.W2136	Urethane	60	101,6 (4,0")	31.75	49.28	19,08/19,20	12.70
60626.W2138	Urethane	80	101,6 (4,0")	31.75	49.28	19,08/19,20	12.70
60626.W2146	Urethane	60	101,6 (4,0")	34.80	49.28	31,78/31,90	12.70
60626.W2148	Urethane	80	101,6 (4,0")	34.80	49.28	31,78/31,90	12.70
60626.W2153	Urethane	35	127,0 (5,0")	31.75	49.28	12,72/12,83	12.70
60626.W2156	Urethane	60	127,0 (5,0")	31.75	49.28	12,72/12,83	12.70
60626.W2158	Urethane	80	127,0 (5,0")	31.75	49.28	12,72/12,83	12.70
60626.W2163	Urethane	35	127,0 (5,0")	31.75	49.28	19,07/19,20	12.70



Solid Roller shaft drive



Rollers & Bumpers

Order No.	Material	Durometer	d ₁	l ₁	d ₂	d ₃	l ₂
60626.W2166	Urethane	60	127,0 (5,0")	31.75	49.28	19,07/19,20	12.70
60626.W2168	Urethane	80	127,0 (5,0")	31.75	49.28	19,07/19,20	12.70
60626.W2173	Urethane	35	127,0 (5,0")	41.40	49.28	31,78/31,90	12.70
60626.W2176	Urethane	60	127,0 (5,0")	41.40	49.28	31,78/31,90	12.70
60626.W2178	Urethane	80	127,0 (5,0")	41.40	49.28	31,78/31,90	12.70
60626.W2183	Urethane	35	152,4 (6,0")	31.75	49.28	12,73/12,83	12.70
60626.W2186	Urethane	60	152,4 (6,0")	31.75	49.28	12,73/12,83	12.70
60626.W2188	Urethane	80	152,4 (6,0")	31.75	49.28	12,73/12,83	12.70
60626.W2193	Urethane	35	152,4 (6,0")	31.75	49.28	19,08/19,20	12.70
60626.W2196	Urethane	60	152,4 (6,0")	31.75	49.28	19,08/19,20	12.70
60626.W2198	Urethane	80	152,4 (6,0")	31.75	49.28	19,08/19,20	12.70
60626.W2203	Urethane	35	152,4 (6,0")	41.40	49.28	31,78/31,90	12.70
60626.W2206	Urethane	60	152,4 (6,0")	41.40	49.28	31,78/31,90	12.70
60626.W2208	Urethane	80	152,4 (6,0")	41.40	49.28	31,78/31,90	12.70
60626.W3002	Neoprene	20	38,10 (1,5")	22.36	31.75	12,72/12,83	9.65
60626.W3003	Neoprene	35	38,10 (1,5")	22.36	31.75	12,72/12,83	9.65
60626.W3006	Neoprene	60	38,10 (1,5")	22.36	31.75	12,72/12,83	9.65
60626.W3008	Neoprene	80	38,10 (1,5")	22.36	31.75	12,72/12,83	9.65
60626.W3012	Neoprene	20	50,80 (2,0")	31.75	23.37	12,72/12,83	12.70
60626.W3013	Neoprene	35	50,80 (2,0")	31.75	23.37	12,72/12,83	12.70
60626.W3016	Neoprene	60	50,80 (2,0")	31.75	23.37	12,72/12,83	12.70
60626.W3018	Neoprene	80	50,80 (2,0")	31.75	23.37	12,72/12,83	12.70
60626.W3022	Neoprene	20	50,80 (2,0")	31.75	23.37	19,08/19,20	12.70
60626.W3023	Neoprene	35	50,80 (2,0")	31.75	23.37	19,08/19,20	12.70
60626.W3026	Neoprene	60	50,80 (2,0")	31.75	23.37	19,08/19,20	12.70
60626.W3028	Neoprene	80	50,80 (2,0")	31.75	23.37	19,08/19,20	12.70
60626.W3032	Neoprene	20	50,80 (2,0")	31.75	49.28	12,73/12,83	12.70
60626.W3033	Neoprene	35	50,80 (2,0")	31.75	49.28	12,73/12,83	12.70
60626.W3036	Neoprene	60	50,80 (2,0")	31.75	49.28	12,73/12,83	12.70
60626.W3038	Neoprene	80	50,80 (2,0")	31.75	49.28	12,73/12,83	12.70
60626.W3042	Neoprene	20	50,80 (2,0")	31.75	49.28	19,08/19,20	12.70
60626.W3043	Neoprene	35	50,80 (2,0")	31.75	49.28	19,08/19,20	12.70
60626.W3046	Neoprene	60	50,80 (2,0")	31.75	49.28	19,08/19,20	12.70
60626.W3048	Neoprene	80	50,80 (2,0")	31.75	49.28	19,08/19,20	12.70
60626.W3052	Neoprene	20	63,50 (2,5")	31.75	23.37	12,73/12,83	12.70
60626.W3053	Neoprene	35	63,50 (2,5")	31.75	23.37	12,73/12,83	12.70
60626.W3056	Neoprene	60	63,50 (2,5")	31.75	23.37	12,73/12,83	12.70
60626.W3058	Neoprene	80	63,50 (2,5")	31.75	23.37	12,73/12,83	12.70
60626.W3062	Neoprene	20	63,50 (2,5")	34.79	23.37	19,08/19,20	12.70
60626.W3063	Neoprene	35	63,50 (2,5")	34.79	23.37	19,08/19,20	12.70
60626.W3066	Neoprene	60	63,50 (2,5")	34.79	23.37	19,08/19,20	12.70
60626.W3068	Neoprene	80	63,50 (2,5")	34.79	23.37	19,08/19,20	12.70
60626.W3072	Neoprene	20	63,50 (2,5")	31.75	49.28	12,73/12,83	12.70
60626.W3073	Neoprene	35	63,50 (2,5")	31.75	49.28	12,73/12,83	12.70
60626.W3076	Neoprene	60	63,50 (2,5")	31.75	49.28	12,73/12,83	12.70
60626.W3078	Neoprene	80	63,50 (2,5")	31.75	49.28	12,73/12,83	12.70
60626.W3082	Neoprene	20	63,50 (2,5")	31.75	49.28	19,08/19,20	12.70
60626.W3083	Neoprene	35	63,50 (2,5")	31.75	49.28	19,08/19,20	12.70
60626.W3086	Neoprene	60	63,50 (2,5")	31.75	49.28	19,08/19,20	12.70
60626.W3088	Neoprene	80	63,50 (2,5")	31.75	49.28	19,08/19,20	12.70
60626.W3092	Neoprene	20	63,50 (2,5")	34.79	49.28	25,42/25,55	12.70
60626.W3093	Neoprene	35	63,50 (2,5")	34.79	49.28	25,42/25,55	12.70
60626.W3096	Neoprene	60	63,50 (2,5")	34.79	49.28	25,42/25,55	12.70
60626.W3098	Neoprene	80	63,50 (2,5")	34.79	49.28	25,42/25,55	12.70
60626.W3102	Neoprene	20	101,6 (4,0")	31.75	23.37	12,73/12,83	12.70
60626.W3103	Neoprene	35	101,6 (4,0")	31.75	23.37	12,73/12,83	12.70
60626.W3106	Neoprene	60	101,6 (4,0")	31.75	23.37	12,73/12,83	12.70
60626.W3108	Neoprene	80	101,6 (4,0")	31.75	23.37	12,73/12,83	12.70
60626.W3112	Neoprene	20	101,6 (4,0")	31.75	23.37	19,08/19,20	12.70
60626.W3113	Neoprene	35	101,6 (4,0")	31.75	23.37	19,08/19,20	12.70
60626.W3116	Neoprene	60	101,6 (4,0")	31.75	23.37	19,08/19,20	12.70
60626.W3118	Neoprene	80	101,6 (4,0")	31.75	23.37	19,08/19,20	12.70
60626.W3122	Neoprene	20	101,6 (4,0")	31.75	49.28	12,73/12,83	12.70
60626.W3123	Neoprene	35	101,6 (4,0")	31.75	49.28	12,73/12,83	12.70
60626.W3126	Neoprene	60	101,6 (4,0")	31.75	49.28	12,73/12,83	12.70
60626.W3128	Neoprene	80	101,6 (4,0")	31.75	49.28	12,73/12,83	12.70
60626.W3132	Neoprene	20	101,6 (4,0")	31.75	49.28	19,08/19,20	12.70
60626.W3133	Neoprene	35	101,6 (4,0")	31.75	49.28	19,08/19,20	12.70
60626.W3136	Neoprene	60	101,6 (4,0")	31.75	49.28	19,08/19,20	12.70

ROLLERS & BUMPERS

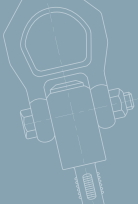

Order No.	Material	Durometer	d ₁	l ₁	d ₂	d ₃	l ₂
60626.W3138	Neoprene	80	101,6 (4,0")	31.75	49.28	19,08/19,20	12.70
60626.W3143	Neoprene	60	101,6 (4,0")	34.80	49.28	31,78/31,90	12.70
60626.W3146	Neoprene	60	101,6 (4,0")	34.80	49.28	31,78/31,90	12.70

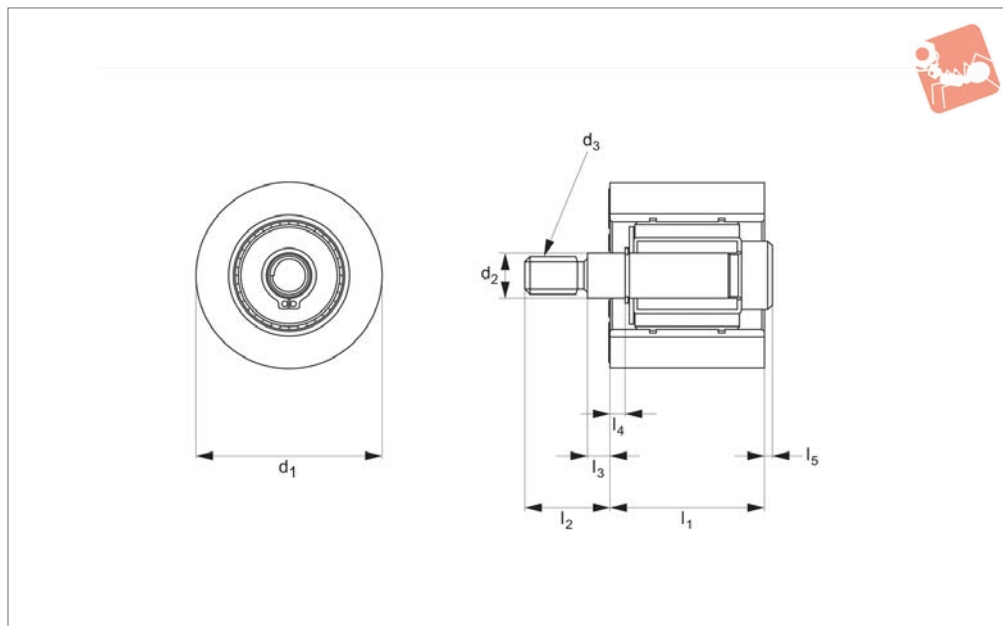
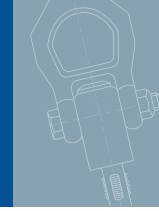

60628

ROLLERS & BUMPERS

Material

Nitrile, urethane or neoprene bonded to a steel insert.
Hardness from 20-80 durometer (Shore A).

Technical Notes

A clutch bearing allows the roller to turn in

only one direction. Available in left or right hand rotation (with the stud pointed upwards, a right hand rotation turns clockwise.)

Supplied with type I bearing, other $d_1=38,1$ roller which is supplied with type h

bearing.

Tips

Type R = Right handed clutch bearing.
Type L = Left handed clutch bearing.
See technical introduction pages for further information.

Order No.	Type	Material	Durometer	d_1	l_1	d_2 -0/+0.05	d_3	l_2	l_3	l_4	l_5
60628.W1002	Right	Nitrile	20	38.10	31.75	9.42	5/16-18"	17.53	4.83	3.05	1.52
60628.W1003	Right	Nitrile	35	38.10	31.75	9.42	5/16-18"	17.53	4.83	3.05	1.52
60628.W1006	Right	Nitrile	60	38.10	31.75	9.42	5/16-18"	17.53	4.83	3.05	1.52
60628.W1008	Right	Nitrile	80	38.10	31.75	9.42	5/16-18"	17.53	4.83	3.05	1.52
60628.W1012	Left	Nitrile	20	38.10	31.75	9.42	5/16-18"	17.53	4.83	3.05	1.52
60628.W1013	Left	Nitrile	35	38.10	31.75	9.42	5/16-18"	17.53	4.83	3.05	1.52
60628.W1016	Left	Nitrile	60	38.10	31.75	9.42	5/16-18"	17.53	4.83	3.05	1.52
60628.W1018	Left	Nitrile	80	38.10	31.75	9.42	5/16-18"	17.53	4.83	3.05	1.52
60628.W1022	Right	Nitrile	20	50.80	23.37	15.77	1/2-13"	45.47	26.42	3.05	10.41
60628.W1023	Right	Nitrile	35	50.80	23.37	15.77	1/2-13"	45.47	26.42	3.05	10.41
60628.W1026	Right	Nitrile	60	50.80	23.37	15.77	1/2-13"	45.47	26.42	3.05	10.41
60628.W1028	Right	Nitrile	80	50.80	23.37	15.77	1/2-13"	45.47	26.42	3.05	10.41
60628.W1032	Left	Nitrile	20	50.80	23.37	15.77	1/2-13"	45.47	26.42	3.05	10.41
60628.W1033	Left	Nitrile	35	50.80	23.37	15.77	1/2-13"	45.47	26.42	3.05	10.41
60628.W1036	Left	Nitrile	60	50.80	23.37	15.77	1/2-13"	45.47	26.42	3.05	10.41
60628.W1038	Left	Nitrile	80	50.80	23.37	15.77	1/2-13"	45.47	26.42	3.05	10.41
60628.W1042	Right	Nitrile	20	50.80	49.28	15.77	1/2-13"	31.75	12.70	3.05	-
60628.W1043	Right	Nitrile	35	50.80	49.28	15.77	1/2-13"	31.75	12.70	3.05	-
60628.W1046	Right	Nitrile	60	50.80	49.28	15.77	1/2-13"	31.75	12.70	3.05	-
60628.W1048	Right	Nitrile	80	50.80	49.28	15.77	1/2-13"	31.75	12.70	3.05	-
60628.W1052	Left	Nitrile	20	50.80	49.28	15.77	1/2-13"	31.75	12.70	3.05	-
60628.W1053	Left	Nitrile	35	50.80	49.28	15.77	1/2-13"	31.75	12.70	3.05	-
60628.W1056	Left	Nitrile	60	50.80	49.28	15.77	1/2-13"	31.75	12.70	3.05	-
60628.W1058	Left	Nitrile	80	50.80	49.28	15.77	1/2-13"	31.75	12.70	3.05	-
60628.W1062	Right	Nitrile	20	63.50	23.27	15.77	1/2-13"	31.75	26.42	3.05	10.41
60628.W1063	Right	Nitrile	35	63.50	23.27	15.77	1/2-13"	31.75	26.42	3.05	10.41
60628.W1066	Right	Nitrile	60	63.50	23.27	15.77	1/2-13"	31.75	26.42	3.05	10.41
60628.W1068	Right	Nitrile	80	63.50	23.27	15.77	1/2-13"	31.75	26.42	3.05	10.41
60628.W1072	Left	Nitrile	20	63.50	23.27	15.77	1/2-13"	31.75	26.42	3.05	10.41
60628.W1073	Left	Nitrile	35	63.50	23.27	15.77	1/2-13"	31.75	26.42	3.05	10.41
60628.W1076	Left	Nitrile	60	63.50	23.27	15.77	1/2-13"	31.75	26.42	3.05	10.41

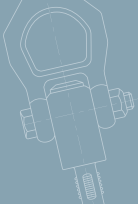

Order No.	Type	Material	Durometer	d ₁	l ₁	d ₂ -0 +0.05	d ₃	l ₂	l ₃	l ₄	l ₅
60628.W1078	Left	Nitrile	80	63.50	23.27	15.77	1/2-13"	31.75	26.42	3.05	10.41
60628.W1082	Right	Nitrile	20	63.50	49.28	15.77	1/2-13"	31.75	12.70	3.05	-
60628.W1083	Right	Nitrile	35	63.50	49.28	15.77	1/2-13"	31.75	12.70	3.05	-
60628.W1086	Right	Nitrile	60	63.50	49.28	15.77	1/2-13"	31.75	12.70	3.05	-
60628.W1088	Right	Nitrile	80	63.50	49.28	15.77	1/2-13"	31.75	12.70	3.05	-
60628.W1092	Left	Nitrile	20	63.50	49.28	15.77	1/2-13"	31.75	12.70	3.05	-
60628.W1093	Left	Nitrile	35	63.50	49.28	15.77	1/2-13"	31.75	12.70	3.05	-
60628.W1096	Left	Nitrile	60	63.50	49.28	15.77	1/2-13"	31.75	12.70	3.05	-
60628.W1098	Left	Nitrile	80	63.50	49.28	15.77	1/2-13"	31.75	12.70	3.05	-
60628.W1102	Right	Nitrile	20	101.6	23.27	15.77	1/2-13"	31.75	26.42	3.05	10.41
60628.W1103	Right	Nitrile	35	101.6	23.27	15.77	1/2-13"	31.75	26.42	3.05	10.41
60628.W1106	Right	Nitrile	60	101.6	23.27	15.77	1/2-13"	31.75	26.42	3.05	10.41
60628.W1108	Right	Nitrile	80	101.6	23.27	15.77	1/2-13"	31.75	26.42	3.05	10.41
60628.W1112	Left	Nitrile	20	101.6	23.27	15.77	1/2-13"	31.75	26.42	3.05	10.41
60628.W1113	Left	Nitrile	35	101.6	23.27	15.77	1/2-13"	31.75	26.42	3.05	10.41
60628.W1116	Left	Nitrile	60	101.6	23.27	15.77	1/2-13"	31.75	26.42	3.05	10.41
60628.W1118	Left	Nitrile	80	101.6	23.27	15.77	1/2-13"	31.75	26.42	3.05	10.41
60628.W1122	Right	Nitrile	20	101.6	49.28	15.77	1/2-13"	31.75	12.70	3.05	-
60628.W1123	Right	Nitrile	35	101.6	49.28	15.77	1/2-13"	31.75	12.70	3.05	-
60628.W1126	Right	Nitrile	60	101.6	49.28	15.77	1/2-13"	31.75	12.70	3.05	-
60628.W1128	Right	Nitrile	80	101.6	49.28	15.77	1/2-13"	31.75	12.70	3.05	-
60628.W1132	Left	Nitrile	20	101.6	49.28	15.77	1/2-13"	31.75	12.70	3.05	-
60628.W1133	Left	Nitrile	35	101.6	49.28	15.77	1/2-13"	31.75	12.70	3.05	-
60628.W1136	Left	Nitrile	60	101.6	49.28	15.77	1/2-13"	31.75	12.70	3.05	-
60628.W1138	Left	Nitrile	80	101.6	49.28	15.77	1/2-13"	31.75	12.70	3.05	-
60628.W2003	Right	Urethane	35	38.10	31.75	9.42	5/16-18"	17.53	4.83	3.05	1.52
60628.W2006	Right	Urethane	60	38.10	31.75	9.42	5/16-18"	17.53	4.83	3.05	1.52
60628.W2008	Right	Urethane	80	38.10	31.75	9.42	5/16-18"	17.53	4.83	3.05	1.52
60628.W2013	Left	Urethane	35	38.10	31.75	9.42	5/16-18"	17.53	4.83	3.05	1.52
60628.W2016	Left	Urethane	60	38.10	31.75	9.42	5/16-18"	17.53	4.83	3.05	1.52
60628.W2018	Left	Urethane	80	38.10	31.75	9.42	5/16-18"	17.53	4.83	3.05	1.52
60628.W2023	Right	Urethane	35	50.80	23.37	15.77	1/2-13"	45.47	26.42	3.05	10.41
60628.W2026	Right	Urethane	60	50.80	23.37	15.77	1/2-13"	45.47	26.42	3.05	10.41
60628.W2028	Right	Urethane	80	50.80	23.37	15.77	1/2-13"	45.47	26.42	3.05	10.41
60628.W2033	Left	Urethane	35	50.80	23.37	15.77	1/2-13"	45.47	26.42	3.05	10.41
60628.W2036	Left	Urethane	60	50.80	23.37	15.77	1/2-13"	45.47	26.42	3.05	10.41
60628.W2038	Left	Urethane	80	50.80	23.37	15.77	1/2-13"	45.47	26.42	3.05	10.41
60628.W2043	Right	Urethane	35	50.80	49.28	15.77	1/2-13"	31.75	12.70	3.05	-
60628.W2046	Right	Urethane	60	50.80	49.28	15.77	1/2-13"	31.75	12.70	3.05	-
60628.W2048	Right	Urethane	80	50.80	49.28	15.77	1/2-13"	31.75	12.70	3.05	-
60628.W2053	Left	Urethane	35	50.80	49.28	15.77	1/2-13"	31.75	12.70	3.05	-
60628.W2056	Left	Urethane	60	50.80	49.28	15.77	1/2-13"	31.75	12.70	3.05	-
60628.W2058	Left	Urethane	80	50.80	49.28	15.77	1/2-13"	31.75	12.70	3.05	-
60628.W2063	Right	Urethane	35	63.50	23.27	15.77	1/2-13"	31.75	26.42	3.05	10.41
60628.W2066	Right	Urethane	60	63.50	23.27	15.77	1/2-13"	31.75	26.42	3.05	10.41
60628.W2068	Right	Urethane	80	63.50	23.27	15.77	1/2-13"	31.75	26.42	3.05	10.41
60628.W2073	Left	Urethane	35	63.50	23.27	15.77	1/2-13"	31.75	26.42	3.05	10.41
60628.W2076	Left	Urethane	60	63.50	23.27	15.77	1/2-13"	31.75	26.42	3.05	10.41
60628.W2078	Left	Urethane	80	63.50	23.27	15.77	1/2-13"	31.75	26.42	3.05	10.41
60628.W2083	Right	Urethane	35	63.50	49.28	15.77	1/2-13"	31.75	12.70	3.05	-
60628.W2086	Right	Urethane	60	63.50	49.28	15.77	1/2-13"	31.75	12.70	3.05	-
60628.W2088	Right	Urethane	80	63.50	49.28	15.77	1/2-13"	31.75	12.70	3.05	-
60628.W2093	Left	Urethane	35	63.50	49.28	15.77	1/2-13"	31.75	12.70	3.05	-
60628.W2096	Left	Urethane	60	63.50	49.28	15.77	1/2-13"	31.75	12.70	3.05	-
60628.W2098	Left	Urethane	80	63.50	49.28	15.77	1/2-13"	31.75	12.70	3.05	-
60628.W2103	Right	Urethane	35	101.6	23.27	15.77	1/2-13"	31.75	26.42	3.05	10.41
60628.W2106	Right	Neoprene	60	101.6	23.27	15.77	1/2-13"	31.75	26.42	3.05	10.41
60628.W2108	Right	Urethane	60	101.6	23.27	15.77	1/2-13"	31.75	26.42	3.05	10.41
60628.W2113	Left	Urethane	80	101.6	23.27	15.77	1/2-13"	31.75	26.42	3.05	10.41
60628.W2116	Left	Urethane	35	101.6	23.27	15.77	1/2-13"	31.75	26.42	3.05	10.41
60628.W2118	Left	Urethane	60	101.6	23.27	15.77	1/2-13"	31.75	26.42	3.05	10.41
60628.W2123	Right	Urethane	80	101.6	49.28	15.77	1/2-13"	31.75	12.70	3.05	-
60628.W2126	Right	Urethane	35	101.6	49.28	15.77	1/2-13"	31.75	12.70	3.05	-
60628.W2128	Right	Urethane	60	101.6	49.28	15.77	1/2-13"	31.75	12.70	3.05	-
60628.W2133	Left	Urethane	80	101.6	49.28	15.77	1/2-13"	31.75	12.70	3.05	-
60628.W2136	Left	Urethane	35	101.6	49.28	15.77	1/2-13"	31.75	12.70	3.05	-
60628.W2138	Left	Urethane	80	101.6	49.28	15.77	1/2-13"	31.75	12.70	3.05	-
60628.W3002	Right	Neoprene	20	38.10	31.75	9.42	5/16-18"	17.53	4.83	3.05	1.52



Solid Roller clutch bearing



Rollers & Bumpers

Order No.	Type	Material	Durometer	d ₁	l ₁	d ₂ -0 +0.05	d ₃	l ₂	l ₃	l ₄	l ₅
60628.W3003	Right	Neoprene	35	38.10	31.75	9.42	5/16-18"	17.53	4.83	3.05	1.52
60628.W3006	Right	Neoprene	60	38.10	31.75	9.42	5/16-18"	17.53	4.83	3.05	1.52
60628.W3008	Right	Neoprene	80	38.10	31.75	9.42	5/16-18"	17.53	4.83	3.05	1.52
60628.W3012	Left	Neoprene	20	38.10	31.75	9.42	5/16-18"	17.53	4.83	3.05	1.52
60628.W3013	Left	Neoprene	35	38.10	31.75	9.42	5/16-18"	17.53	4.83	3.05	1.52
60628.W3016	Left	Neoprene	60	38.10	31.75	9.42	5/16-18"	17.53	4.83	3.05	1.52
60628.W3018	Left	Neoprene	80	38.10	31.75	9.42	5/16-18"	17.53	4.83	3.05	1.52
60628.W3022	Right	Neoprene	20	50.80	23.37	15.77	1/2-13"	45.47	26.42	3.05	10.41
60628.W3023	Right	Neoprene	35	50.80	23.37	15.77	1/2-13"	45.47	26.42	3.05	10.41
60628.W3026	Right	Neoprene	60	50.80	23.37	15.77	1/2-13"	45.47	26.42	3.05	10.41
60628.W3028	Right	Neoprene	80	50.80	23.37	15.77	1/2-13"	45.47	26.42	3.05	10.41
60628.W3032	Left	Neoprene	20	50.80	23.37	15.77	1/2-13"	45.47	26.42	3.05	10.41
60628.W3033	Left	Neoprene	35	50.80	23.37	15.77	1/2-13"	45.47	26.42	3.05	10.41
60628.W3036	Left	Neoprene	60	50.80	23.37	15.77	1/2-13"	45.47	26.42	3.05	10.41
60628.W3038	Left	Neoprene	80	50.80	23.37	15.77	1/2-13"	45.47	26.42	3.05	10.41
60628.W3042	Right	Neoprene	20	50.80	49.28	15.77	1/2-13"	31.75	12.70	3.05	-
60628.W3043	Right	Neoprene	35	50.80	49.28	15.77	1/2-13"	31.75	12.70	3.05	-
60628.W3046	Right	Neoprene	60	50.80	49.28	15.77	1/2-13"	31.75	12.70	3.05	-
60628.W3048	Right	Neoprene	80	50.80	49.28	15.77	1/2-13"	31.75	12.70	3.05	-
60628.W3052	Left	Neoprene	20	50.80	49.28	15.77	1/2-13"	31.75	12.70	3.05	-
60628.W3053	Left	Neoprene	35	50.80	49.28	15.77	1/2-13"	31.75	12.70	3.05	-
60628.W3056	Left	Neoprene	60	50.80	49.28	15.77	1/2-13"	31.75	12.70	3.05	-
60628.W3058	Left	Neoprene	80	50.80	49.28	15.77	1/2-13"	31.75	12.70	3.05	-
60628.W3062	Right	Neoprene	20	63.50	23.27	15.77	1/2-13"	31.75	26.42	3.05	10.41
60628.W3063	Right	Neoprene	35	63.50	23.27	15.77	1/2-13"	31.75	26.42	3.05	10.41
60628.W3066	Right	Neoprene	60	63.50	23.27	15.77	1/2-13"	31.75	26.42	3.05	10.41
60628.W3068	Right	Neoprene	80	63.50	23.27	15.77	1/2-13"	31.75	26.42	3.05	10.41
60628.W3072	Left	Neoprene	20	63.50	23.27	15.77	1/2-13"	31.75	26.42	3.05	10.41
60628.W3073	Left	Neoprene	35	63.50	23.27	15.77	1/2-13"	31.75	26.42	3.05	10.41
60628.W3076	Left	Neoprene	60	63.50	23.27	15.77	1/2-13"	31.75	26.42	3.05	10.41
60628.W3078	Left	Neoprene	80	63.50	23.27	15.77	1/2-13"	31.75	26.42	3.05	10.41
60628.W3082	Right	Neoprene	20	63.50	49.28	15.77	1/2-13"	31.75	12.70	3.05	-
60628.W3083	Right	Neoprene	35	63.50	49.28	15.77	1/2-13"	31.75	12.70	3.05	-
60628.W3086	Right	Neoprene	60	63.50	49.28	15.77	1/2-13"	31.75	12.70	3.05	-
60628.W3088	Right	Neoprene	80	63.50	49.28	15.77	1/2-13"	31.75	12.70	3.05	-
60628.W3092	Left	Neoprene	20	63.50	49.28	15.77	1/2-13"	31.75	12.70	3.05	-
60628.W3093	Left	Neoprene	35	63.50	49.28	15.77	1/2-13"	31.75	12.70	3.05	-
60628.W3096	Left	Neoprene	60	63.50	49.28	15.77	1/2-13"	31.75	12.70	3.05	-
60628.W3098	Left	Neoprene	80	63.50	49.28	15.77	1/2-13"	31.75	12.70	3.05	-
60628.W3102	Right	Neoprene	20	101.6	23.27	15.77	1/2-13"	31.75	26.42	3.05	10.41
60628.W3103	Right	Neoprene	35	101.6	23.27	15.77	1/2-13"	31.75	26.42	3.05	10.41
60628.W3108	Right	Neoprene	80	101.6	23.27	15.77	1/2-13"	31.75	26.42	3.05	10.41
60628.W3112	Left	Neoprene	20	101.6	23.27	15.77	1/2-13"	31.75	26.42	3.05	10.41
60628.W3113	Left	Neoprene	35	101.6	23.27	15.77	1/2-13"	31.75	26.42	3.05	10.41
60628.W3116	Left	Neoprene	60	101.6	23.27	15.77	1/2-13"	31.75	26.42	3.05	10.41
60628.W3118	Left	Neoprene	80	101.6	23.27	15.77	1/2-13"	31.75	26.42	3.05	10.41
60628.W3122	Right	Neoprene	20	101.6	49.28	15.77	1/2-13"	31.75	12.70	3.05	-
60628.W3123	Right	Neoprene	35	101.6	49.28	15.77	1/2-13"	31.75	12.70	3.05	-
60628.W3126	Right	Neoprene	60	101.6	49.28	15.77	1/2-13"	31.75	12.70	3.05	-
60628.W3128	Right	Neoprene	80	101.6	49.28	15.77	1/2-13"	31.75	12.70	3.05	-
60628.W3132	Left	Neoprene	20	101.6	49.28	15.77	1/2-13"	31.75	12.70	3.05	-
60628.W3133	Left	Neoprene	35	101.6	49.28	15.77	1/2-13"	31.75	12.70	3.05	-
60628.W3136	Left	Neoprene	60	101.6	49.28	15.77	1/2-13"	31.75	12.70	3.05	-
60628.W3138	Left	Neoprene	80	101.6	49.28	15.77	1/2-13"	31.75	12.70	3.05	-

ROLLERS & BUMPERS

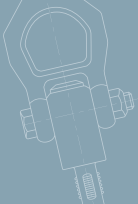

60610

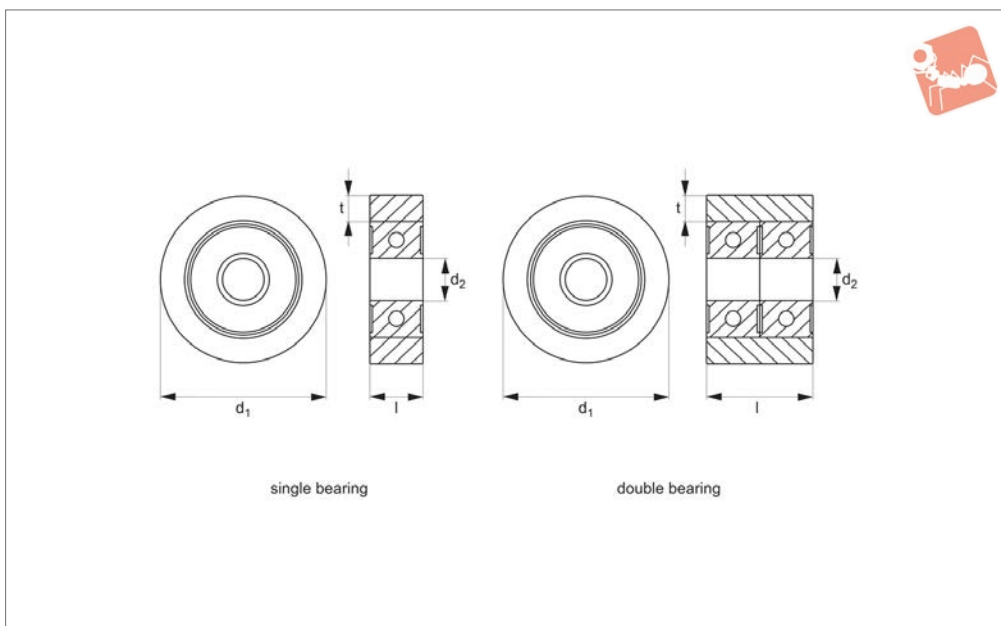

Material

Urethane cast directly to a precision sealed ball bearing. Hardness from 35-95 durometer (Shore A).

Technical Notes

These bearings provide a smooth, quiet and non-marring operation. Urethane provides excellent durability and resi-

stance to abrasion.

Order No.	Bearing type	Durometer	d ₁	d ₂	l	t
60610.W0003	Single	35	20	5	5	3
60610.W0006	Single	60	20	5	5	3
60610.W0009	Single	95	20	5	5	3
60610.W0013	Single	35	25	6	6	3
60610.W0016	Single	60	25	6	6	3
60610.W0019	Single	95	25	6	6	3
60610.W0023	Single	35	30	8	7	4
60610.W0026	Single	60	30	8	7	4
60610.W0029	Single	95	30	8	7	4
60610.W0033	Single	35	35	9	7	6
60610.W0036	Single	60	35	9	7	6
60610.W0039	Single	95	35	9	7	6
60610.W0043	Single	35	35	10	8	5
60610.W0046	Single	60	35	10	8	5
60610.W0049	Single	95	35	10	8	5
60610.W0053	Single	35	40	10	8	7
60610.W0056	Single	60	40	10	8	7
60610.W0059	Single	95	40	10	8	7
60610.W0063	Single	35	40	12	8	6
60610.W0066	Single	60	40	12	8	6
60610.W0069	Single	95	40	12	8	6
60610.W0073	Single	35	50	12	8	11
60610.W0076	Single	60	50	12	8	11
60610.W0079	Single	95	50	12	8	11
60610.W0089	Single	95	45	15	9	7
60610.W0099	Single	95	50	17	10	8
60610.W0109	Single	95	60	20	12	9
60610.W1003	Double	35	20	5	10	3
60610.W1006	Double	60	20	5	10	3
60610.W1009	Double	95	20	5	10	3
60610.W1013	Double	35	25	6	12	3
60610.W1016	Double	60	25	6	12	3
60610.W1019	Double	95	25	6	12	3
60610.W1023	Double	35	30	8	14	4
60610.W1026	Double	60	30	8	14	4

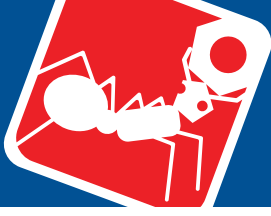

Urethane Covered Bearings bearing only

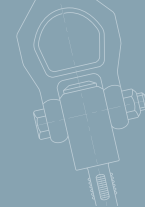

Rollers & Bumpers

Order No.	Bearing type	Durometer	d ₁	d ₂	l	t
60610.W1029	Double	95	30	8	14	4
60610.W1033	Double	35	35	9	14	6
60610.W1036	Double	60	35	9	14	6
60610.W1039	Double	95	35	9	14	6
60610.W1043	Double	35	35	10	16	5
60610.W1046	Double	60	35	10	16	5
60610.W1049	Double	95	35	10	16	5
60610.W1053	Double	35	40	10	16	7
60610.W1056	Double	60	40	10	16	7
60610.W1059	Double	95	40	10	16	7
60610.W1063	Double	35	40	12	16	6
60610.W1066	Double	60	40	12	16	6
60610.W1069	Double	95	40	12	16	6
60610.W1073	Double	35	50	12	16	11
60610.W1076	Double	60	50	12	16	11
60610.W1079	Double	95	50	12	16	11
60610.W1089	Double	95	45	15	18	7
60610.W1099	Double	95	50	17	20	8
60610.W1109	Double	95	60	20	24	9
60610.W1119	Double	95	70	25	24	12
60610.W0119	Single	95	70	25	12	12

ROLLERS & BUMPERS

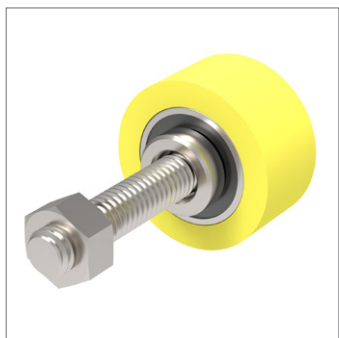

60614

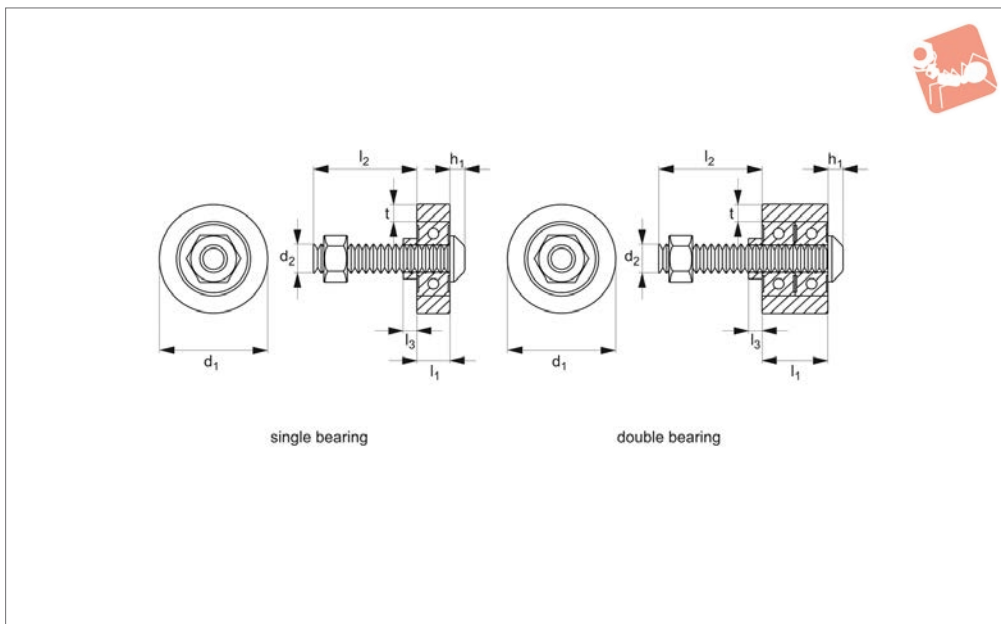

Material

Urethane cast directly to a precision sealed ball bearing. Hardness from 35-95 durometer (Shore A).

Technical Notes

These bearings provide a smooth, quiet and non-marring operation. Urethane provides excellent durability and resi-

stance to abrasion. Assembled with button head cap screw, spacer and lock nut.

Order No.	Bearing type	Durometer	d ₁	l ₁	d ₂	l ₂	d ₃	t	h
60614.W1003	Double	35	20	10	M5x0.8	25	3	3	2.75
60614.W1006	Double	60	20	10	M5x0.8	25	3	3	2.75
60614.W1009	Double	95	20	10	M5x0.8	25	3	3	2.75
60614.W1013	Double	35	25	12	M6x1.0	28	3	3	3.3
60614.W1016	Double	60	25	12	M6x1.0	28	3	3	3.3
60614.W1019	Double	95	25	12	M6x1.0	28	3	3	3.3
60614.W1023	Double	35	30	14	M8x1.25	26	3	4	4.4
60614.W1026	Double	60	30	14	M8x1.25	26	3	4	4.4
60614.W1029	Double	95	30	14	M8x1.25	26	3	4	4.4
60614.W1033	Double	35	35	16	M10x1.5	29	3	4.5	5.5
60614.W1036	Double	60	35	16	M10x1.5	29	3	4.5	5.5
60614.W1039	Double	95	35	16	M10x1.5	29	3	4.5	5.5
60614.W1043	Double	35	40	16	M10x1.5	29	3	7	5.5
60614.W1046	Double	60	40	16	M10x1.5	29	3	7	5.5
60614.W1049	Double	95	40	16	M10x1.5	29	3	7	5.5
60614.W1053	Double	35	40	16	M12x1.75	29	3	6	6.6
60614.W1056	Double	60	40	16	M12x1.75	29	3	6	6.6
60614.W1059	Double	95	40	16	M12x1.75	29	3	6	6.6
60614.W1063	Double	35	50	16	M12x1.75	29	3	11	6.6
60614.W1066	Double	60	50	16	M12x1.75	29	3	11	6.6
60614.W1069	Double	95	50	16	M12x1.75	29	3	11	6.6
60614.W0003	Single	35	20	5	M5x0.8	30	3	3	2.75
60614.W0006	Single	60	20	5	M5x0.8	30	3	3	2.75
60614.W0009	Single	95	20	5	M5x0.8	30	3	3	2.75
60614.W0013	Single	35	25	6	M6x1.0	34	3	3	3.3
60614.W0016	Single	60	25	6	M6x1.0	34	3	3	3.3
60614.W0019	Single	95	25	6	M6x1.0	34	3	3	3.3
60614.W0023	Single	35	30	7	M8x1.25	33	3	4	4.4
60614.W0026	Single	60	30	7	M8x1.25	33	3	4	4.4
60614.W0029	Single	95	30	7	M8x1.25	33	3	4	4.4
60614.W0033	Single	35	35	8	M10x1.5	37	3	4.5	5.5
60614.W0036	Single	60	35	8	M10x1.5	37	3	4.5	5.5
60614.W0039	Single	95	35	8	M10x1.5	37	3	4.5	5.5
60614.W0043	Single	35	40	8	M10x1.5	37	3	7	5.5
60614.W0046	Single	60	40	8	M10x1.5	37	3	7	5.5



Urethane Covered Bearings stud mounted

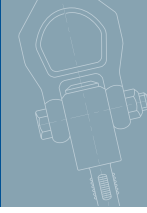

Rollers & Bumpers

Order No.	Bearing type	Durometer	d ₁	l ₁	d ₂	l ₂	d ₃	t	h
60614.W0049	Single	95	40	8	M10x1.5	37	3	7	5.5
60614.W0053	Single	35	40	8	M12x1.75	37	3	6	6.6
60614.W0056	Single	60	40	8	M12x1.75	37	3	6	6.6
60614.W0059	Single	95	40	8	M12x1.75	37	3	6	6.6
60614.W0063	Single	35	50	8	M12x1.75	37	3	11	6.6
60614.W0066	Single	60	50	8	M12x1.75	37	3	11	6.6
60614.W0069	Single	95	50	8	M12x1.75	37	3	11	6.6



67202

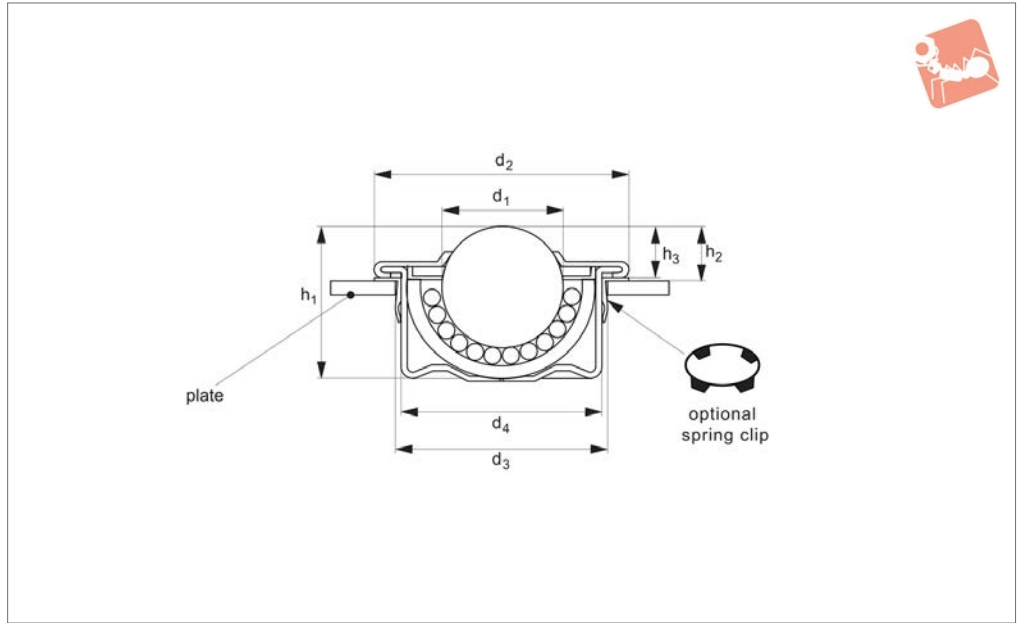

Material

Steel (zinc plated), stainless steel (AISI 416 for housing and AISI 420 for balls) and acetal (POM).

Technical Notes

Cost-effective and light-weight units formed from sheet steel material. No reduction in load carrying capacity even

when installed upside down. Sizes 22 and 30 have a felt seal for the ball. Low friction 1:0,03, speeds up to 1m/s. Temperature range -20°C to +70°C.

Tips

To compensate for irregular bore diameters we recommend using the spring clip (stainless) part no. P2730.

Clip requires a minimum plate thickness of 3mm to grip securely. These rollers can only be used in the horizontal or „ball up“ direction.

Order No.	d ₁	d ₂	h ₁	h ₂	d ₃ min.	d ₃ max.	d ₄	h ₃	Housing	Ball	Load kg max.
67202.W0151	15	31	21	10.1	25	25.5	24	9.8	Steel	Steel	60
67202.W0154	15	31	21	10.1	25	25.5	24	9.8	Steel	Stainless	60
67202.W0155	15	31	21	10.1	25	25.5	24	9.8	Steel	Acetal	10
67202.W0152	15	31	21	10.1	25	25.5	24	9.8	Stainless	Stainless	40
67202.W0221	22	45	29.5	10.4	37.0	37.5	36	10.1	Steel	Steel	160
67202.W0224	22	45	29.5	10.4	37.0	37.5	36	10.1	Steel	Stainless	160
67202.W0225	22	45	29.5	10.4	37.0	37.5	36	10.1	Steel	Acetal	20
67202.W0222	22	45	29.5	10.4	37.0	37.5	36	10.1	Stainless	Stainless	90
67202.W0301	30	55	37	14.4	46	46.5	45	14.1	Steel	Steel	280
67202.W0304	30	55	37	14.4	46	46.5	45	14.1	Steel	Stainless	280
67202.W0305	30	55	37	14.4	46	46.5	45	14.1	Steel	Acetal	25
67202.W0302	30	55	37	14.4	46	46.5	45	14.1	Stainless	Stainless	200



Acetal Body Ball Transfer Units

light duty, acetal body

Transfer Rollers

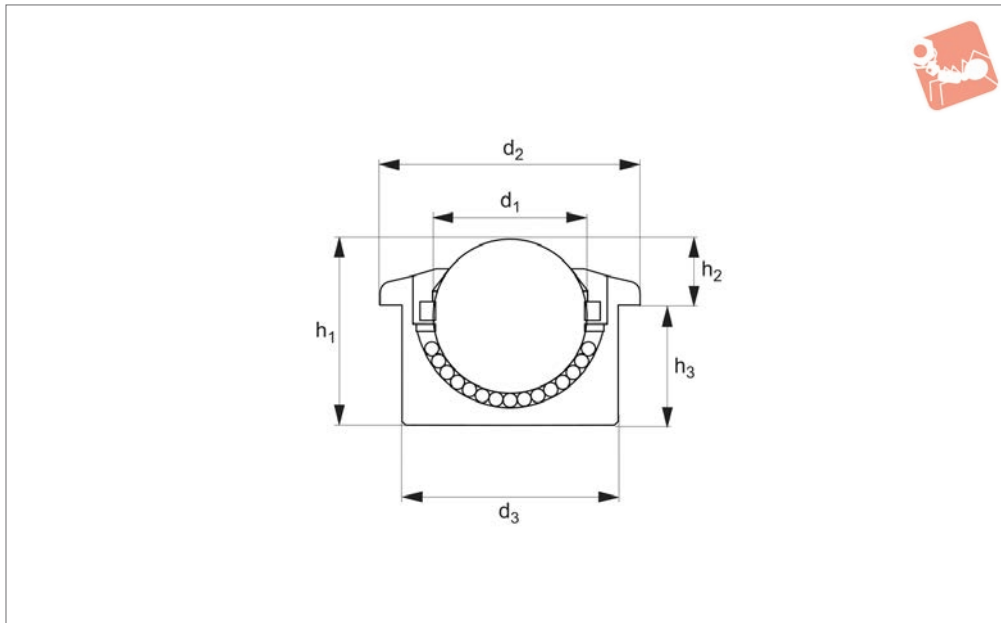

67204

TRANSFER ROLLERS

Material

Acetal (POM) housing with acetal or stainless (AISI 316) balls.

Technical Notes

Push-fit units, these acetal units resist

salt water and chemicals.

They are non-conductive and non-magnetic, low friction 1:0,03.

Temperature range -20°C to +70°C, speeds up to 1m/s.

Tips

These rollers can only be used in the horizontal or „ball up“ direction.

Order No.	d ₁	d ₂	h ₁	h ₂	d ₃	h ₃	Housing	Ball
67204.W0156	15	31	21	9.5	24	11.5	Acetal	Stainless
67204.W0157	15	31	21	9.5	24	11.5	Acetal	Acetal
67204.W0226	22	45	30.5	9.8	36	20.7	Acetal	Stainless
67204.W0227	22	45	30.5	9.8	36	20.7	Acetal	Acetal
67204.W0306	30	55	37	13.8	45	23.2	Acetal	Stainless
67204.W0307	30	55	37	13.8	45	23.2	Acetal	Acetal
67204.W0456	45	75	53.5	19	62	34.5	Acetal	Stainless
67204.W0457	45	75	53.5	19	62	34.5	Acetal	Acetal



67208

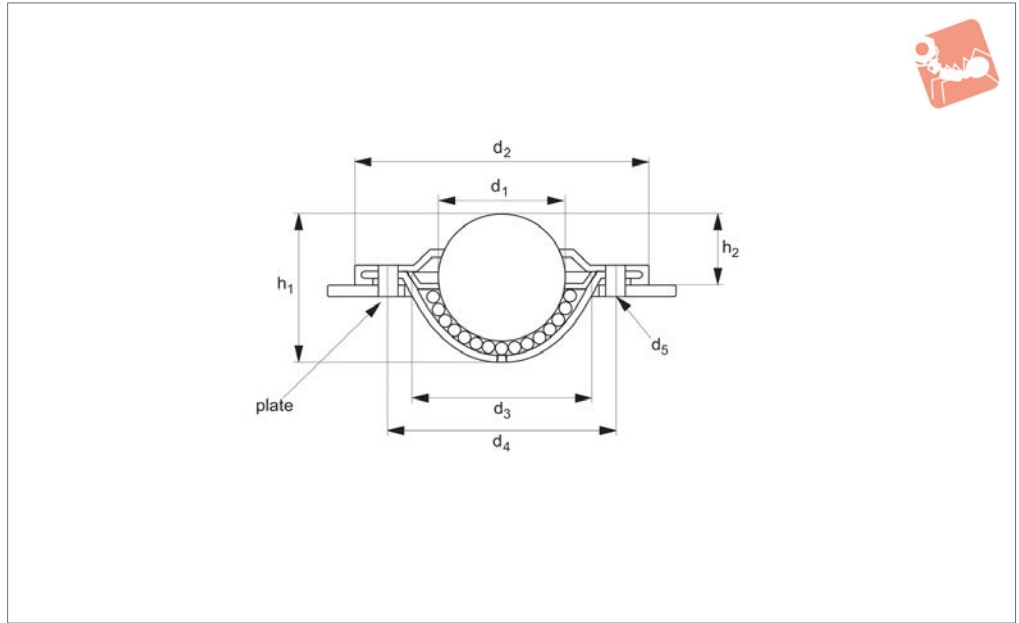

Material

Steel (AISI 1040 housing and AISI 52100 for balls), stainless steel (AISI 416 for housing and AISI 420 for balls) and acetal (POM).

Technical Notes

Cost-effective and light-weight units

formed from sheet steel material.

No reduction in load carrying capacity even when installed upside down.

Low friction 1:0,03, temperature range - 20°C to +70°C, speeds up to 1m/s.

Tips

These rollers can only be used in the hori-

zontal or „ball up“ direction.

67208.320-SS and 67208.330-SS have 7 large fluid drain holes & no felt seal.

Order No.	d ₁	d ₂	h ₁	h ₂	d ₃	d ₄	d ₅	Housing	Ball	Load kg max.
67208.W0161	15	41.0	19.3	10.8	24.0	30.0	2 x 3,4	Steel	Steel	15
67208.W0164	15	41.0	19.3	10.8	24.0	30.0	2 x 3,4	Steel	Stainless	10
67208.W0165	15	41.0	19.3	10.8	24.0	30.0	2 x 3,4	Steel	Acetal	10
67208.W0221	23	45.0	27.7	9.8	33.0	39.0	3 x 3,5	Steel	Steel	120
67208.W0225	23	45.0	27.7	9.8	33.0	39.0	3 x 3,5	Steel	Acetal	90
67208.W0322	32	73.7	36.1	16.2	45.5	58.7	2 x 5,5	Stainless	Stainless	125
67208.W0255	25	56.0	30.0	14.6	36.0	45.0	2 x 4,0	Steel	Acetal	22
67208.W0332	32	74.0	36.1	16.2	46.0	58.7	3 x 5,5	Stainless	Stainless	125
67208.W0224	23	45.0	27.7	9.8	33.0	39.0	3 x 3,5	Steel	Stainless	22
67208.W0252	25	56.0	30.0	14.6	36.0	45.0	2 x 4,0	Steel	Steel	60
67208.W0254	25	56.0	30.0	14.6	36.0	45.0	2 x 4,0	Steel	Stainless	40
67208.W0251	25	47.1	29.6	14.3	38.1	-	-	Stainless	Stainless	55



Product selection

Housing	Ball	Load Factor	
Steel	Steel	1,0	Housing: AISI 1040 steel, machined, toughened & zinc plated. Ball: AISI 52100 chrome steel
Steel	Stainless	0,7	Housing: AISI 1040 steel, machined, toughened & zinc plated. Ball: AISI 420 stainless steel
Stainless	Stainless	0,7	Housing: AISI 416 stainless steel. Ball: AISI 420 stainless steel
Steel	Acetal		Housing: AISI 1040 steel, machined, toughened & zinc plated. Ball: POM acetal
Aluminium	Stainless		Housing: aluminium. Ball: AISI 420 stainless steel
Acetal	Acetal		Housing: POM acetal. Ball: POM acetal
Acetal	Stainless		Housing: POM acetal. Ball: AISI 420 stainless steel

Available materials

Part No.	Ball Size	Minimum Bore ø	Maximum Bore ø
67202.W9015	15	24,8	25,0
67202.W9022	22	37,0	37,2
67202.W9030	30	46,3	46,7

Fixing clip selection

Clip requires a minimum plate thickness of 3mm to grip securely

Ball Type	Max Load (Kg)	Friction (% of load)	Speed (m/s)	Shock Loads	Arduous Conditions	Orientation	Instant Change
Medium Duty	20-3500	2%	1,5	✓✓✓	✓✓		✓✓✓
Light Duty	7-250	3%	1,0	✓	✓✓		✓✓✓

How to select the correct unit



Shock Loads:
Specify High Capacity series & spring loaded units



Track Hardness/Conveyed Item Material:
Standard material ball units have Rockwell 'C' hardness of 60 minimum



Delicate Surfaces:
Ball Units - Acetal (POM) & Phenolic Resin



Operating Environment:
Wet, dirty, outdoor, radioactive

Variables to consider

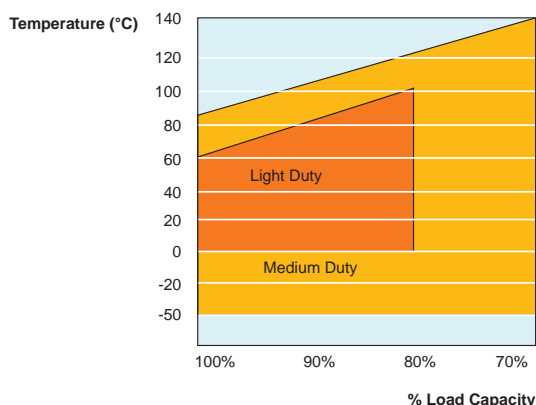

Operation temperature

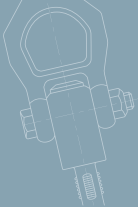

Load and stability

To determine the load of a ball transfer unit, the weight of the article to be conveyed should be divided by 3. If the height tolerance of the load balls is good and the surface of the workpiece to be conveyed is suitable, the calculation can be based on the number of ball transfer units under the load.

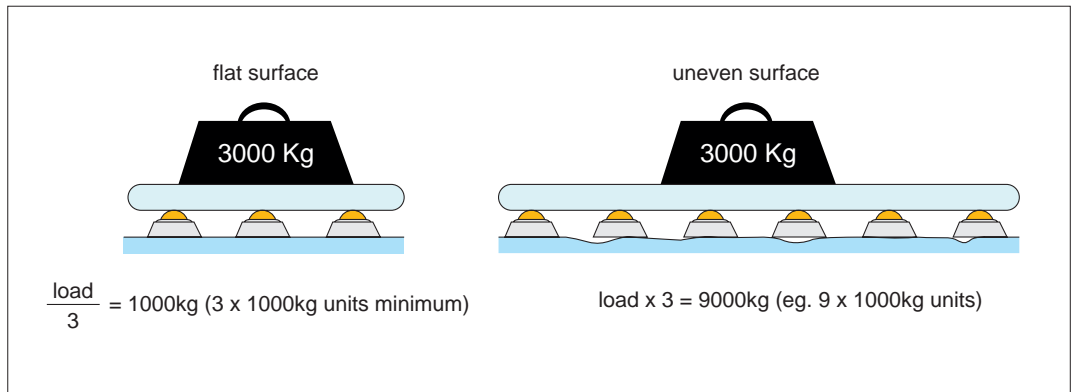

Pitching and spacing

How the ball transfer units should be arranged depends on the bottom surface of the load to be transported. For loads with a uniform, even bottom surface, e.g. packing cases, the distance between the ball transfer units is calculated by dividing the smallest dimension by 3,5.

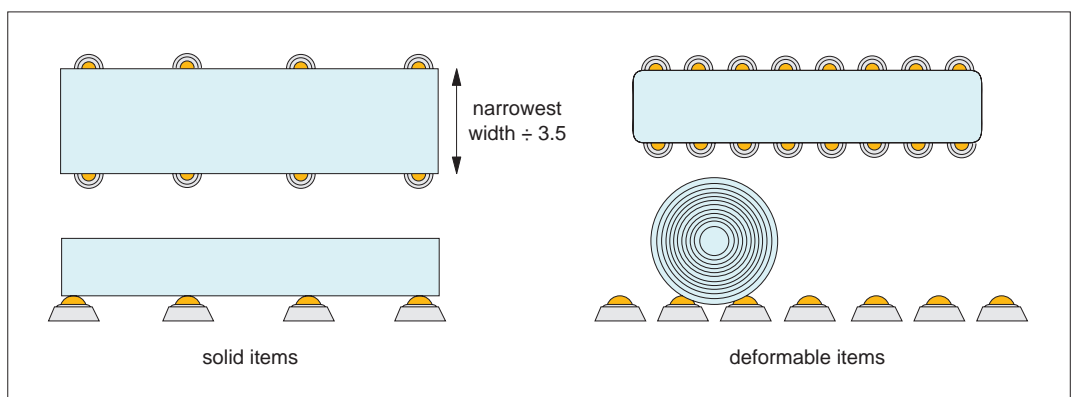

Conveying speed and load capacity

The maximum conveying speed allowed amounts to 2m/s. The load capacities specified apply to any mounting position and are based on 10^6 rotations of the load ball. With the units being used over a longer time at speeds exceeding 1m/s, an increase in temperature as well as a reduction in travel life must be expected depending on the load.

Calculation of travel life

$$L = \frac{C^3}{F} 10^6 \text{ rotations}$$

L = travel life
C = load capacity (N)
F = load (N)

Friction

The diagram shows the friction values as a function of load and speed for ball transfer units. These approximate values apply to all mounting positions with operation on a hardened steel plate.

v = 1m/s

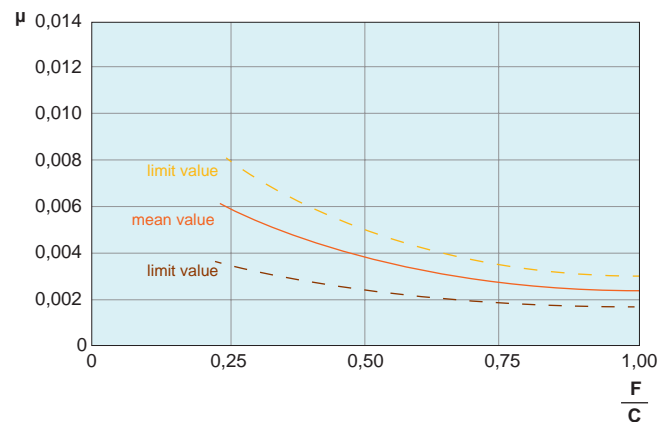



Push-Fit Ball Transfer Units

medium duty

Transfer Rollers



67220

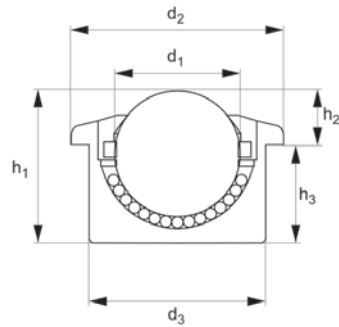

Material

Steel (AISI 1040 housing and AISI 52100 for balls), stainless steel (AISI 416 for housing and AISI 420 for balls) and acetal (POM).

Technical Notes

These ball transfer units are made of a solid steel block

with a precision machined hemispherical carrying bowl. Top cover plates are shaped to ensure the perfect conveyance of items which have possible burred or bent edges. This design also prevents possible damage to the carrying ball. Provided with a hole in the base of the

bearing cup to dispose of particles of dirt and swarf (this may also be used for re-lubrication purposes).

Tips

These rollers can only be used in the horizontal or ball up direction.

Order No.	d ₁	d ₂	h ₁	h ₂	d ₃	h ₃	Housing	Ball	Load kg max.
67220.W0454	45	75	53.5	19.0	62	34.5	Steel	Stainless	600
67220.W0304	30	55	36.8	13.8	45	23.0	Steel	Stainless	350
67220.W0254	25	46	30.5	13.0	38	17.5	Steel	Stainless	140
67220.W0224	22	45	30.5	9.8	36	20.7	Steel	Stainless	180
67220.W0154	15	30	20	8.1	24	11.9	Steel	Stainless	50
67220.W0124	12	27	16.7	8.0	22	8.7	Steel	Stainless	20
67220.W0121	12	27	16.7	8.0	22	8.7	Steel	Steel	25
67220.W0125	12	27	16.7	8.0	22	8.7	Steel	Acetal	5
67220.W0122	12	27	16.7	8.0	22	8.7	Stainless	Stainless	20
67220.W0151	15	30	20	8.1	24	11.9	Steel	Steel	60
67220.W0155	15	30	20	8.1	24	11.9	Steel	Acetal	10
67220.W0152	15	30	20	8.1	24	11.9	Stainless	Stainless	40
67220.W0161	15	31	21	9.5	24	11.5	Steel	Steel	60
67220.W0165	15	31	21	9.5	24	11.5	Steel	Acetal	10
67220.W0164	15	31	21	9.5	24	11.5	Steel	Acetal	50
67220.W0162	15	31	21	9.5	24	11.5	Stainless	Stainless	40
67220.W0221	22	45	30.5	9.8	36	20.7	Steel	Steel	180
67220.W0225	22	45	30.5	9.8	36	20.7	Steel	Acetal	20
67220.W0222	22	45	30.5	9.8	36	20.7	Stainless	Stainless	126
67220.W0251	25	46	30.5	13.0	38	17.5	Steel	Steel	200
67220.W0255	25	46	30.5	13.0	38	17.5	Steel	Acetal	25
67220.W0252	25	46	30.5	13.0	38	17.5	Stainless	Stainless	140
67220.W0301	30	55	36.8	13.8	45	23.0	Steel	Steel	350
67220.W0305	30	55	36.8	13.8	45	23.0	Steel	Acetal	25
67220.W0302	30	55	36.8	13.8	45	23.0	Stainless	Stainless	220
67220.W0451	45	75	53.5	19.0	62	34.5	Steel	Steel	600
67220.W0455	45	75	53.5	19.0	62	34.5	Steel	Acetal	25
67220.W0452	45	75	53.5	19.0	62	34.5	Stainless	Stainless	350



Order No.	d ₁	d ₂	h ₁	h ₂	d ₃	h ₃	Housing	Ball	Load kg max.
67220.W0601	60	117	77.5	30.0	100	47.5	Steel	Steel	1500
67220.W0605	60	117	77.5	30.0	100	47.5	Steel	Acetal	35
67220.W0602	60	117	77.5	30.0	100	47.5	Stainless	Stainless	1050

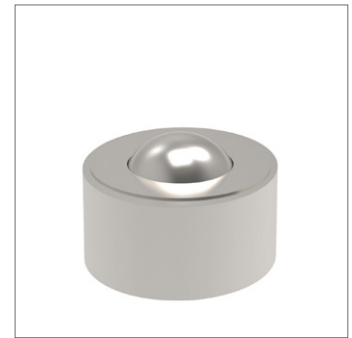
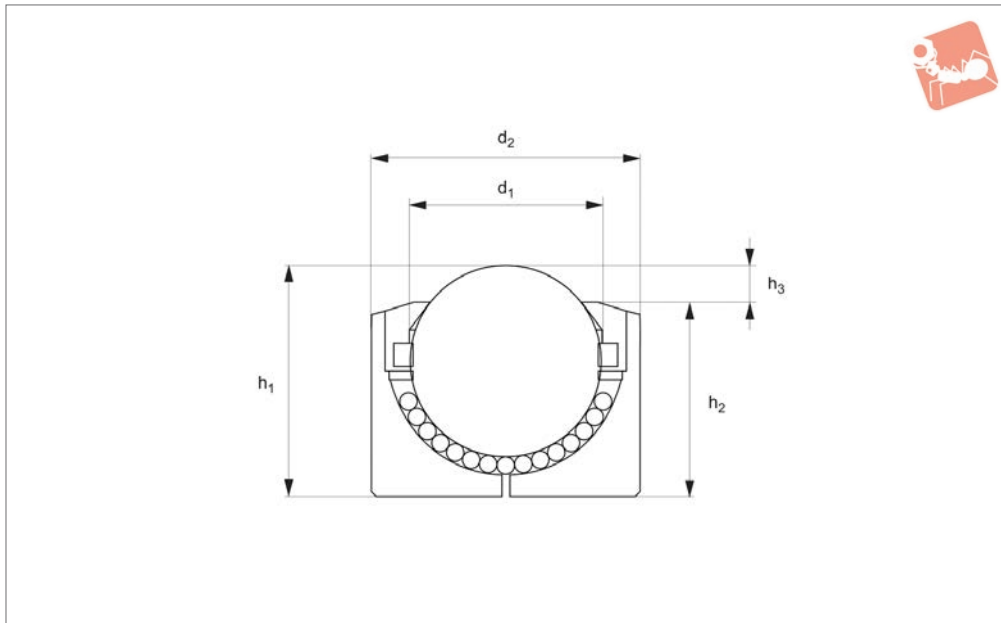

67222

TRANSFER ROLLERS

Material

Steel (AISI 1040 housing and AISI 52100 for balls),
stainless steel (AISI 416 for housing and AISI 420 for balls) and acetal (POM).

Technical Notes

These ball transfer units are made of a solid steel block with a precision machined hemispherical carrying bowl.

Top cover plates are shaped to ensure the perfect conveyance of items which have possible burred or bent edges. This design also prevents possible damage to the carrying ball.

Provided with a hole in the base of the bearing cup to dispose of particles of dirt and swarf (this may also be used for re-lubrication purposes).

Manufactured without a flange on the housing, therefore the whole load is being supported only by the bottom face of the unit.

Tips

These rollers can only be used in the horizontal or „ball up“ direction.

Order No.	d ₁	d ₂	h ₁	h ₂	h ₃	Housing	Ball	Load kg max.
67222.W0081	8	18	12.0	10.0	2.0	Steel	Steel	13
67222.W0084	8	18	12.0	10.0	2.0	Steel	Stainless	10
67222.W0082	8	18	12.0	10.0	2.0	Stainless	Stainless	8.4
67222.W0124	12	20	16.5	13.5	3.0	Steel	Stainless	20
67222.W0154	15	24	20.0	15.0	5.0	Steel	Stainless	50
67222.W0224	22	36	30.5	27.9	4.5	Steel	Stainless	180
67222.W0304	30	45	36.8	30.3	6.5	Steel	Stainless	350
67222.W0454	45	62	53.5	45.0	8.5	Steel	Stainless	600
67222.W0604	60	100	77.5	61	16.5	Steel	Stainless	1100
67222.W0121	12	20	16.5	13.5	3.0	Steel	Steel	25
67222.W0125	12	20	16.5	13.5	3.0	Steel	Acetal	5
67222.W0122	12	20	16.5	13.5	3.0	Stainless	Stainless	14
67222.W0151	15	24	20.0	15.0	5.0	Steel	Steel	60
67222.W0155	15	24	20.0	15.0	5.0	Steel	Acetal	10
67222.W0152	15	24	20.0	15.0	5.0	Stainless	Stainless	40
67222.W0221	22	36	30.5	27.9	4.5	Steel	Steel	180
67222.W0225	22	36	30.5	27.9	4.5	Steel	Acetal	20
67222.W0222	22	36	30.5	27.9	2.6	Stainless	Stainless	125
67222.W0301	30	45	36.8	30.3	6.5	Steel	Steel	350
67222.W0305	30	45	36.8	30.3	6.5	Steel	Acetal	25
67222.W0302	30	45	36.8	30.3	6.5	Stainless	Stainless	245
67222.W0451	45	62	53.5	45.0	8.5	Steel	Steel	600
67222.W0455	45	62	53.5	45.0	8.5	Steel	Acetal	25
67222.W0452	45	62	53.5	45.0	8.5	Stainless	Stainless	420
67222.W0601	60	100	77.5	61	16.5	Steel	Steel	1500



Order No.	d ₁	d ₂	h ₁	h ₂	h ₃	Housing	Ball	Load kg max.
67222.W0605	60	100	77.5	61	16.5	Steel	Acetal	35
67222.W0602	60	100	77.5	61	16.5	Stainless	Stainless	1000



Threaded Ball Transfer Units

medium duty, female

Transfer Rollers

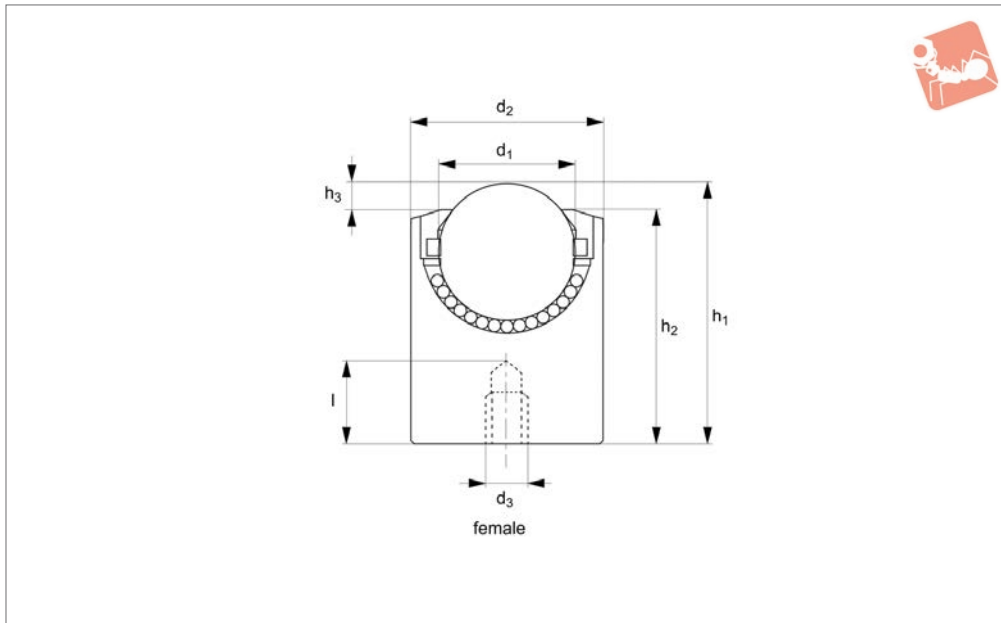

67224

TRANSFER ROLLERS

Material

Steel (AISI 1040 housing and AISI 52100 for balls), stainless steel (AISI 416 for housing and AISI 420 for balls) and acetal (POM).

Technical Notes

These ball transfer units are made of a solid steel block with a precision machined hemispherical

carrying bowl.

Top cover plates are shaped to ensure the perfect conveyance of items which have possible burred or bent edges. This design also prevents possible damage to the carrying ball.

Provided with a hole in the base of the bearing cup to dispose of particles of dirt and swarf

(this may also be used for re-lubrication purposes).

Manufactured without a flange on the housing, therefore the whole load is being supported only by the bottom face of the unit.

Tips

For male version see .

Order No.	Type	d ₁	d ₂	h ₁	h ₂	d ₃	h ₃	l ₁	Housing	Ball	Load kg max.
67224.W1121	Female	12	22	24.0	20.5	M8	3.5	5	Steel	Steel	25
67224.W1125	Female	12	22	24.0	20.5	M8	3.5	5	Steel	Acetal	5
67224.W1122	Female	12	22	24.0	20.5	M8	3.5	5	Stainless	Stainless	17
67224.W1124	Female	12	22	24.0	20.5	M8	3.5	5	Steel	Stainless	20
67224.W1224	Female	22	36	40.5	34	M8	4.5	10	Steel	Stainless	180
67224.W1454	Female	45	62	63.5	50.5	M8	13.0	10	Steel	Stainless	600
67224.W1304	Female	30	45	46.8	38.8	M8	8.0	10	Steel	Stainless	350
67224.W1154	Female	15	24	28.0	23	M8	5.0	8	Steel	Stainless	50
67224.W1151	Female	15	24	28.0	23	M8	5.0	8	Steel	Steel	60
67224.W1155	Female	15	24	28.0	23	M8	5.0	8	Steel	Acetal	10
67224.W1152	Female	15	24	28.0	23	M8	5.0	8	Stainless	Stainless	40
67224.W1221	Female	22	36	40.5	34	M8	4.5	10	Steel	Steel	180
67224.W1225	Female	22	36	40.5	34	M8	4.5	10	Steel	Acetal	20
67224.W1222	Female	22	36	40.5	34	M8	4.5	10	Stainless	Stainless	126
67224.W1301	Female	30	45	46.8	38.8	M8	8.0	10	Steel	Steel	350
67224.W1305	Female	30	45	46.8	38.8	M8	8.0	10	Steel	Acetal	25
67224.W1302	Female	30	45	46.8	38.8	M8	8.0	10	Stainless	Stainless	245
67224.W1451	Female	45	62	63.5	50.5	M8	13.0	10	Steel	Steel	600
67224.W1455	Female	45	62	63.5	50.5	M8	13.0	10	Steel	Acetal	25
67224.W1452	Female	45	62	63.5	50.5	M8	13.0	10	Stainless	Stainless	420



67200

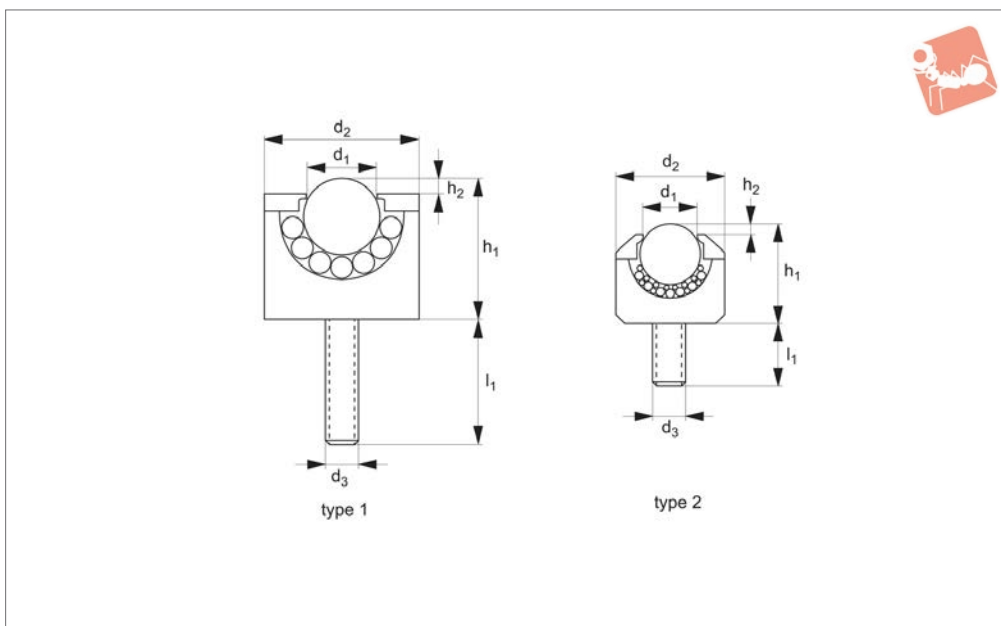

Material

Carbon steel, aluminium or stainless steel housing. Carbon steel or stainless steel balls.

Technical Notes

All steel parts are supplied with a small

amount of oil, to protect from oxidation.

Tips

Normally used in measuring equipment, small linear motion systems (e.g photocopier slides) and miniature mechanisms.

Order No.	Type	d ₁	d ₂	h ₁	h ₂	d ₃	h ₃	Housing	Ball	Load kg max.
67200.W0051	type 1	4.8	13	9	1	M6	15	Steel	Steel	10
67200.W0151	type 1	15.8	28	20.5	4	M6	12	Steel	Steel	70
67200.W0152	type 1	15.8	24	20.5	4	M6	12	Stainless	Stainless	70
67200.W0162	type 1	15.8	24	20.5	4	M6	12	Stainless	Stainless	70
67200.W0052	type 1	4.8	13	9	1	M6	15	Stainless	Stainless	10
67200.W0053	type 2	4.8	8	6	1	M2	2.5	Aluminium	Stainless	5
67200.W0072	type 1	6.4	17	11	2	M6	15	Stainless	Stainless	20
67200.W0065	type 2	6.4	13	10.5	2	M3	6	Aluminium	Stainless	10
67200.W0082	type 1	8	18	12	2	M6	15	Stainless	Stainless	30
67200.W0093	type 2	7.9	15	12.5	2	M4	8	Aluminium	Stainless	15
67200.W0101	type 1	9.6	23	20	2	M8	20	Steel	Steel	40
67200.W0102	type 1	9.6	23	20	2	M8	20	Stainless	Stainless	40
67200.W0131	type 1	12.7	28	25	3.5	M8	23	Steel	Steel	50
67200.W0132	type 1	12.7	28	25	3.5	M8	23	Stainless	Stainless	50



Minature Shock Absorbers, Self M8 - M12, non-adjustable

Shock Absorbers

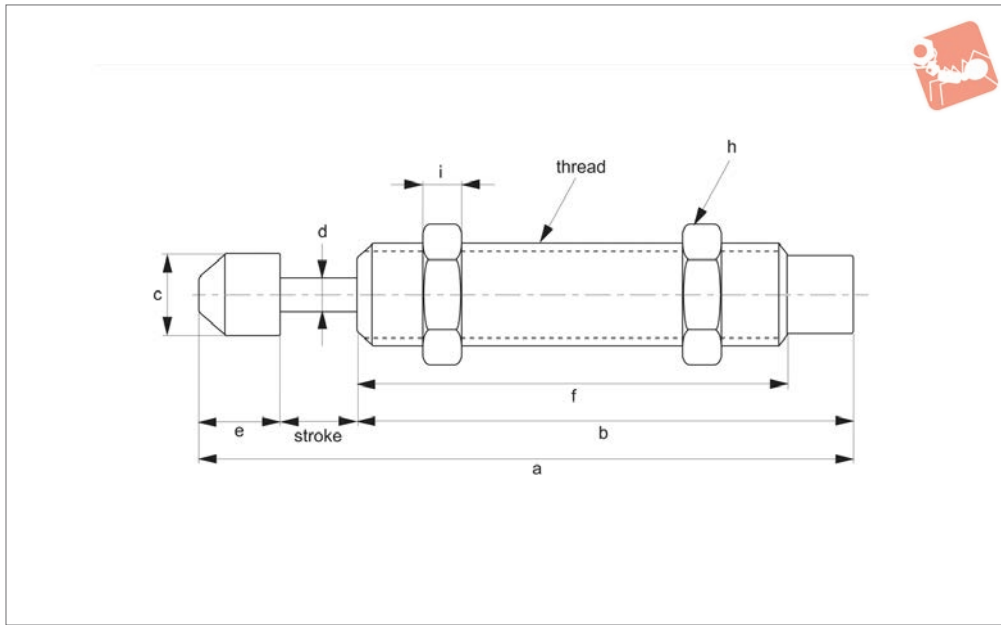

68001

SHOCK ABSORBERS

Material

Outer Tube: STKM11A, hardened and blackened.
Piston Rod: AISI 1045 hardened to HV940°, chrome plated.
Return Spring: DIN GWP.
Muffler Cap: urethane rubber.
Seal: nitrile rubber.

Technical Notes

Supplied with rubber muffler cap as standard, this is removable - see introductory technical notes for guidance.

Tips

Select High Impact Speed model for hard impact at start of stroke. For hard set down

at end of stroke choose a Medium or Low Impact Speed model.

Important Notes

For correct product selection refer to Product Selection Formulae and Calculation pages, and associated Capacity & Selection Charts.

Order No.	Stroke mm	Nm per cycle (Et) Nm max.	Per hour (ETc) Nm max.	Effective mass (Me) kg max.	Impact speed (v) m/s max.	Impact speed (v) m/s max.	Operating temperature °C	Thre ad	a	b	c	d	e	f	h	i	Weig ht g
68001.W0109	10	4	108 00	3.0	Low	0.5	-10 to +80	M10 x0,7 5	66.8	49.5	8.0	3.0	8.0	44.5	12.7	3	20.0

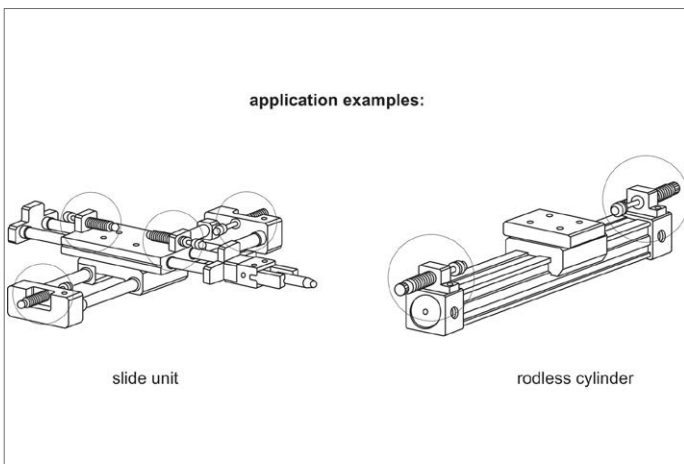



68002

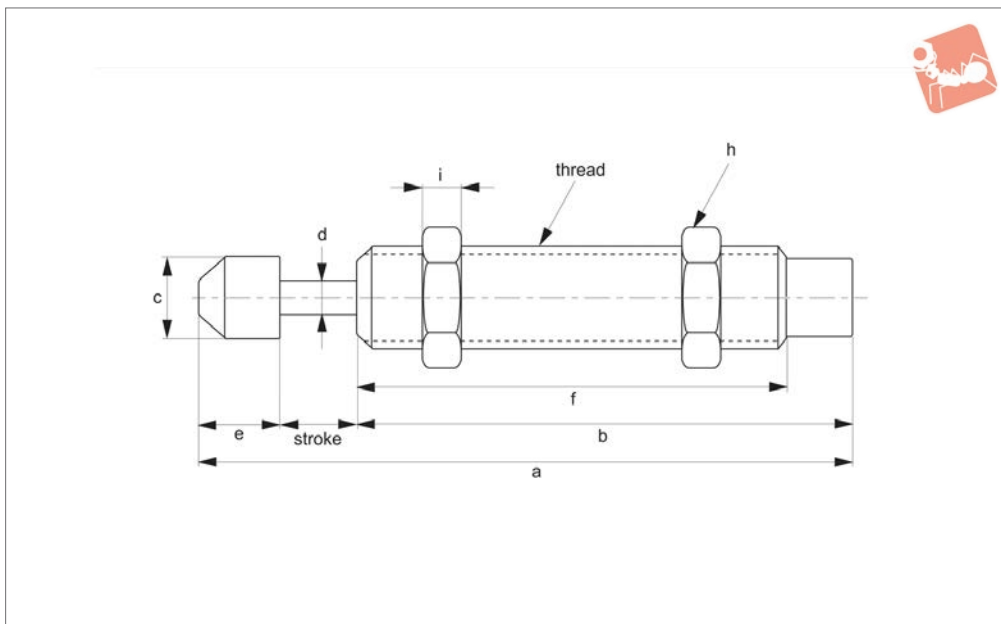

Material

Outer Tube: STKM11A, hardened and blackened.

Piston Rod: AISI 1045 hardened to HV940°, chrome plated.

Return Spring: DIN GWP.

Muffler Cap: urethane rubber. Seal: nitrile rubber.

Technical Notes

Supplied with rubber muffler cap as standard, this is removable - see introductory technical notes for guidance.

Tips

Select High Impact Speed model for hard impact at start of stroke. For hard set down

at end of stroke choose a Medium or Low Impact Speed model.

Important Notes

For correct product selection refer to Product Selection Formulae and Calculation pages, and associated Capacity & Selection Charts.

Order No.	Stroke mm	Nm per cycle (Et)		Per hour (ETc)	Effective mass (Me)	Impact speed (v)	Impact speed (v)	Operating temperature	Weight
		Nm max.	Nm max.						
68002.W0140	8	12	22000		6	High	3.0	-10 to +80	65
68002.W0141	12	15	30000		8	High	3.0	-10 to +80	80
68002.W0142	12	15	30000		50	Med	1.5	-10 to +80	80
68002.W0143	12	15	30000		100	Low	0.8	-10 to +80	80
68002.W0144	16	20	35000		10	Low	3.0	-10 to +80	85
68002.W0145	16	20	35000		70	Low	1.5	-10 to +80	85
68002.W0146	16	20	35000		150	Low	0.8	-10 to +80	85
68002.W0147	16	20	35000		10	High	3.0	-10 to +80	80
68002.W0148	16	20	35000		70	Med	1.5	-10 to +80	80
68002.W0149	16	20	35000		150	Low	0.8	-10 to +80	80
68002.W0198	20	20	35000		10	High	3.0	-10 to +80	95
68002.W0199	20	20	35000		70	Med	1.5	-10 to +80	95
68002.WX200	10	16	42000		30	Low	3.5	-10 to +80	165
68002.W0200	20	20	35000		150	Low	0.8	-10 to +80	95
68002.W0201	20	40	40000		30	High	3.5	-10 to +80	215
68002.W0202	20	40	40000		200	Med	2.0	-10 to +80	215
68002.W0203	20	40	40000		700	Low	1.0	-10 to +80	215
68002.W0204	30	50	48000		30	High	3.5	-10 to +80	220
68002.W0205	30	50	48000		200	Med	2.0	-10 to +80	220
68002.W0206	30	50	48000		700	Low	1.0	-10 to +80	220
68002.W0207	50	60	60000		60	High	3.5	-10 to +80	300
68002.W0208	50	60	60000		400	Med	2.0	-10 to +80	300
68002.W0209	50	60	60000		1200	Low	1.0	-10 to +80	300

Order No.	Thread	a	b	c	d	e	f	h	i
68002.W0140	M14x1,5	73.5	55.0	12.0	4.0	11.2	50.5	19	5
68002.W0141	M14x1,5	98.5	76	12	4	10.5	67	19	5



Shock Absorbers, Self Compensating

M14 - M20, non adjustable

Shock Absorbers

Order No.	Thread	a	b	c	d	e	f	h	i
68002.W0142	M14x1,5	98.5	76	12	4	10.5	67	19	5
68002.W0143	M14x1,5	98.5	76	12	4	10.5	67	19	5
68002.W0144	M14x1,5	122.2	95.0	12.0	4.0	11.2	86.0	19.0	5.0
68002.W0145	M14x1,5	122.2	95.0	12.0	4.0	11.2	86.0	19.0	5.0
68002.W0146	M14x1,5	122.2	95.0	12.0	4.0	11.2	86.0	19.0	5.0
68002.W0147	M14x1,5	102.5	76	12	4	10.5	67	19	5
68002.W0148	M14x1,5	102.5	76	12	4	10.5	67	19	5
68002.W0149	M14x1,5	102.5	76	12	4	10.5	67	19	5
68002.W0198	M14x1,5	125.5	95	12	4	10.5	86	19	5
68002.W0199	M14x1,5	125.5	95	12	4	10.5	86	19	5
68002.WX200	M16x1,5	68.0	58.0	10.0	5.0	8.0	40.0	19.0	6.0
68002.W0200	M14x1,5	125.5	95	12	4	10.5	86	19	5
68002.W0201	M20x1,5	145.8	110	18	6	15.8	101	26	7
68002.W0202	M20x1,5	145.8	110	18	6	15.8	101	26	7
68002.W0203	M20x1,5	145.8	110	18	6	15.8	101	26	7
68002.W0204	M20x1,5	158.8	113	18	6	15.8	104	26	7
68002.W0205	M20x1,5	158.8	113	18	6	15.8	104	26	7
68002.W0206	M20x1,5	158.8	113	18	6	15.8	104	26	7
68002.W0207	M20x1,5	232.8	167	18	6	15.8	158	26	7
68002.W0208	M20x1,5	232.8	167	18	6	15.8	158	26	7
68002.W0209	M20x1,5	232.8	167	18	6	15.8	158	26	7

SHOCK ABSORBERS

application examples:

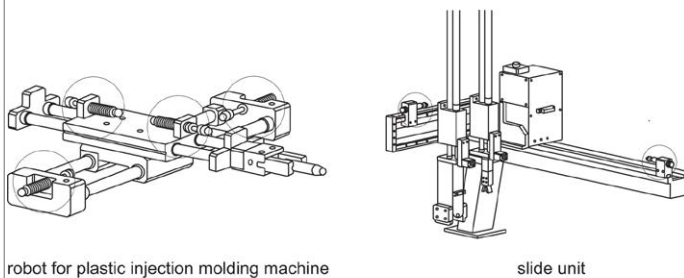

robot for plastic injection molding machine

slide unit



SHOCK ABSORBERS



68003

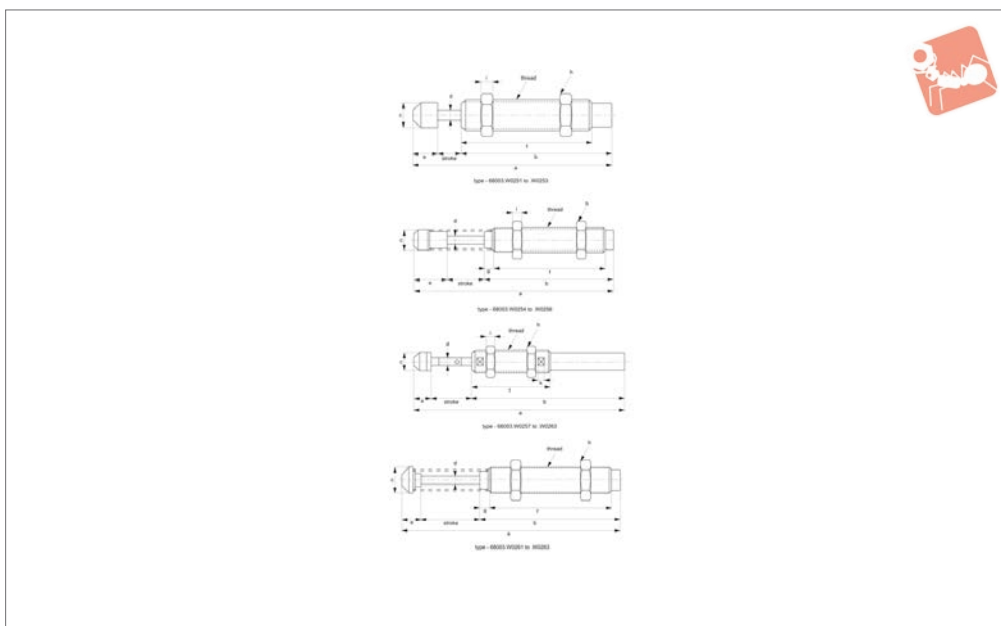

Material

Outer Tube: STKM11A, hardened and blackened.

Piston Rod: AISI 1045 hardened to HV940°, chrome plated.

Return Spring: DIN GWP.

Muffler Cap: urethane rubber. **Seal:** nitrile rubber.

Technical Notes

Supplied with rubber muffler cap as standard, this is removable - see introductory technical notes for guidance.

Tips

Select High Impact Speed model for hard impact at start of stroke. For hard set down

at end of stroke choose a Medium or Low Impact Speed model.

Important Notes

For correct product selection refer to Product Selection Formulae and Calculation pages, and associated Capacity & Selection Charts.

Order No.	Stroke mm	Nm per cycle (Et)		Per hour (ETc)	Effective mass (Me) kg max.	Impact speed (v)	Impact speed (v) m/s max.	Operating temperature °C	Weight g
		Nm max.	Nm max.						
68003.W0251	25	80	80	54000	200	High	4.0	-10 to +80	330
68003.W0252	25	80	80	54000	800	Med	2.5	-10 to +80	330
68003.W0253	25	80	80	54000	1500	Low	1.0	-10 to +80	330
68003.W0254	40	120	120	75000	300	High	4.0	-10 to +80	430
68003.W0255	40	120	120	75000	1200	Med	2.5	-10 to +80	430
68003.W0256	40	120	120	75000	2000	Low	1.0	-10 to +80	430
68003.W0257	50	98	98	90000	15	High	4.0	-10 to +80	435
68003.W0258	50	98	98	90000	40	Med	2.5	-10 to +80	435
68003.W0259	50	98	98	90000	160	Low	1.0	-10 to +80	435
68003.W0261	80	150	150	120000	20	High	4.0	-10 to +80	535
68003.W0262	80	150	150	120000	50	Med	2.5	-10 to +80	535
68003.W0263	80	150	150	120000	200	Low	1.0	-10 to +80	535
68003.W0361	60	250	250	120000	400	High	4.0	-10 to +80	1,030
68003.W0362	60	250	250	120000	1500	Med	2.5	-10 to +80	1,030
68003.W0363	60	250	250	120000	2400	Low	1.0	-10 to +80	1,030

Order No.	Thread	a	b	c	d	e	f	h	g	i	j	k
68003.W0251	M25x1,5	155.0	111.0	22.0	8	19.5	101.0	32	-	9	-	-
68003.W0252	M25x1,5	155.0	111.0	22.0	8	19.5	101.0	32	-	9	-	-
68003.W0253	M25x1,5	155.0	111.0	22.0	8	19.5	101.0	32	-	9	-	-
68003.W0254	M25x1,5	214.0	127.0	22.0	8	36.0	117.0	32	10	9	-	-
68003.W0255	M25x1,5	214.0	127.0	22.0	8	36.0	117.0	32	10	9	-	-
68003.W0256	M25x1,5	214.0	127.0	22.0	8	36.0	117.0	32	10	9	-	-
68003.W0257	M25x1,5	239.5	170.5	22.0	8	19.5	100.0	32	-	9	-	-
68003.W0258	M25x1,5	239.5	170.5	22.0	8	19.5	100.0	32	-	9	-	-
68003.W0259	M25x1,5	239.5	170.5	22.0	8	19.5	100.0	32	-	9	-	-
68003.W0261	M25x1,5	336.0	237.0	22.0	8	19.5	100.0	32	-	9	23	11



Shock Absorbers, Self Compensating

M25 - M36, non-adjustable

Shock Absorbers

Order No.	Thread	a	b	c	d	e	f	h	g	i	j	k
68003.W0262	M25x1,5	336.0	237.0	22.0	8	19.5	100.0	32	-	9	23	11
68003.W0263	M25x1,5	336.0	237.0	22.0	8	19.5	100.0	32	-	9	23	11
68003.W0361	M36x1,5	248.0	162.0	35.5	10	26.0	134.0	46	17	15	23	11
68003.W0362	M36x1,5	248.0	162.0	35.5	10	26.0	134.0	46	17	15	23	11
68003.W0363	M36x1,5	248.0	162.0	35.5	10	26.0	134.0	46	17	15	23	11

SHOCK ABSORBERS



68004

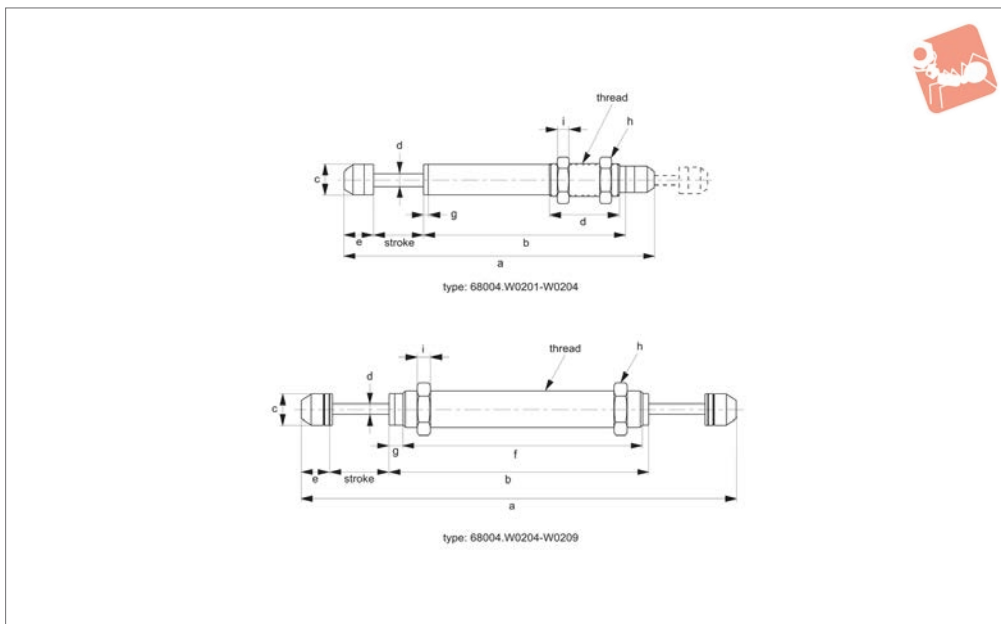

Material

Outer Tube: STKM11A, hardened and blackened.

Piston Rod: AISI 1045 hardened to HV940°, chrome plated.

Return Spring: DIN GWP.

Muffler Cap: urethane rubber. **Seal:** nitrile rubber.

Technical Notes

Supplied with rubber muffler cap as standard, this is removable - see introductory technical notes for guidance.

Tips

Select High Impact Speed model for hard impact at start of stroke. For hard set down

at end of stroke choose a Medium or Low Impact Speed model.

Important Notes

For correct product selection refer to Product Selection Formulae and Calculation pages, and associated Capacity & Selection Charts.

Order No.	Stroke mm	Nm per cycle (Et)		Per hour (ETc)	Effective mass (Me)	Impact speed (v)	Impact speed (v)	Operating temperature	Weight
		Nm max.	Nm max.						
68004.W0201	30	45	45	55000	40	High	3.5	-10 to +80	320
68004.W0202	30	45	45	55000	300	Med	2.0	-10 to +80	320
68004.W0203	30	45	45	55000	900	Low	1.0	-10 to +80	320
68004.W0204	35	52	52	63000	40	High	3.5	-10 to +80	350
68004.W0205	35	52	52	63000	200	Med	2.0	-10 to +80	350
68004.W0206	35	52	52	63000	650	Low	1.0	-10 to +80	350
68004.W0207	50	60	60	68000	60	High	3.5	-10 to +80	470
68004.W0208	50	60	60	68000	210	Med	2.0	-10 to +80	470
68004.W0209	50	60	60	68000	480	Low	1.0	-10 to +80	470
68004.W0210	50	70	70	72000	530	Low	3.5	-10 to +80	480

Order No.	Thread	a	b	c	d	e	f	h	g	i
68004.W0201	M20x1,5	183.6	123	18	6	15.8	44	26	3	7
68004.W0202	M20x1,5	183.6	123	18	6	15.8	44	26	3	7
68004.W0203	M20x1,5	183.6	123	18	6	15.8	44	26	3	7
68004.W0204	M20x1,5	224.6	123	18	5	15.8	42	26	5	7
68004.W0205	M20x1,5	224.6	123	18	5	15.8	42	26	5	7
68004.W0206	M20x1,5	224.6	123	18	5	15.8	42	26	5	7
68004.W0207	M20x1,5	276.6	145	18	6	15.8	134	26	8	7
68004.W0208	M20x1,5	276.6	145	18	6	15.8	134	26	8	7
68004.W0209	M20x1,5	276.6	145	18	6	15.8	134	26	8	7
68004.W0210	M20x1,5	313.8	172.8	17.8	6	20.5	11	26	16	7



Shock Absorber Self Compensating M30, non-adustable

Shock Absorbers

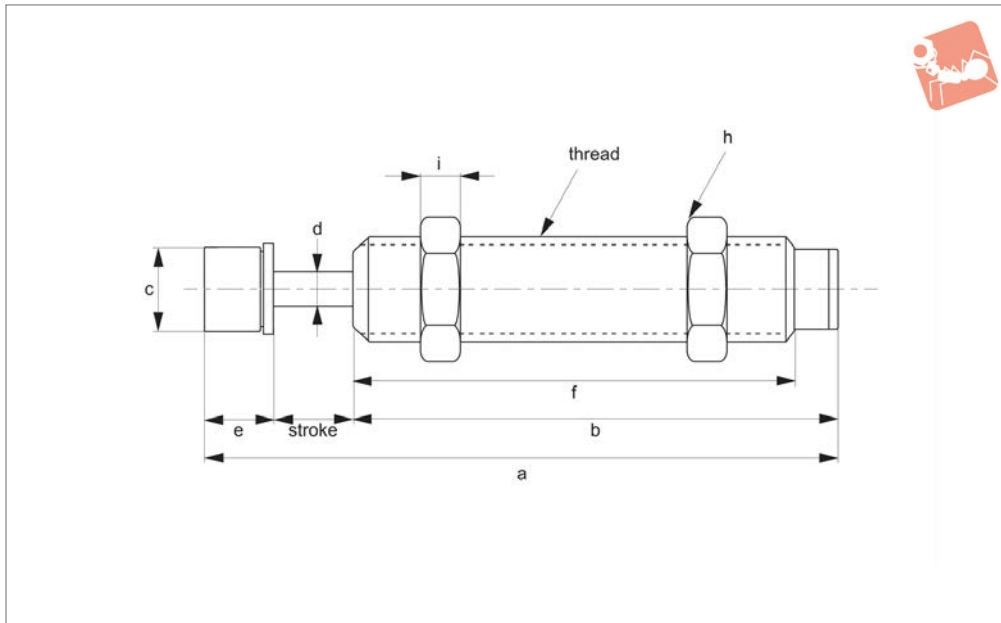

68005

SHOCK ABSORBERS

Material

Outer Tube: STKM11A, hardened and blackened.

Piston Rod: AISI 1045 hardened to HV940°, chrome plated.

Return Spring: DIN GWP.

Muffler Cap: urethane rubber. **Seal:** nitrile rubber.

Technical Notes

Supplied with rubber muffler cap as standard, this is removable - see introductory technical notes for guidance.

Tips

Select High Impact Speed model for hard impact at start of stroke. For hard set down

at end of stroke choose a Medium or Low Impact Speed model.

Important Notes

For correct product selection refer to Product Selection Formulae and Calculation pages, and associated Capacity & Selection Charts.

Order No.	Stroke mm	Nm per cycle (Et)		Per hour (ETc)		Effective mass (Me) kg max.	Impact speed (v)	Impact speed (v)		Weight g
		Nm max.	Nm max.	Nm max.	Nm max.			m/s max.	m/s max.	
68005.W0301	25	180	180	60000	60000	300	High	3.0	3.0	950
68005.W0302	25	180	180	60000	60000	700	Med	2.0	2.0	950
68005.W0303	25	180	180	60000	60000	1300	Low	1.0	1.0	950

Order No.	Operating temperature °C	Thread	a	b	c	d	e	f	h	i
68005.W0302	-10~+80	M30x1,5	151	106.5	27	10	19.5	94.5	36	14
68005.W0303	-10~+80	M30x1,5	151	106.5	27	10	19.5	94.5	36	14



68008

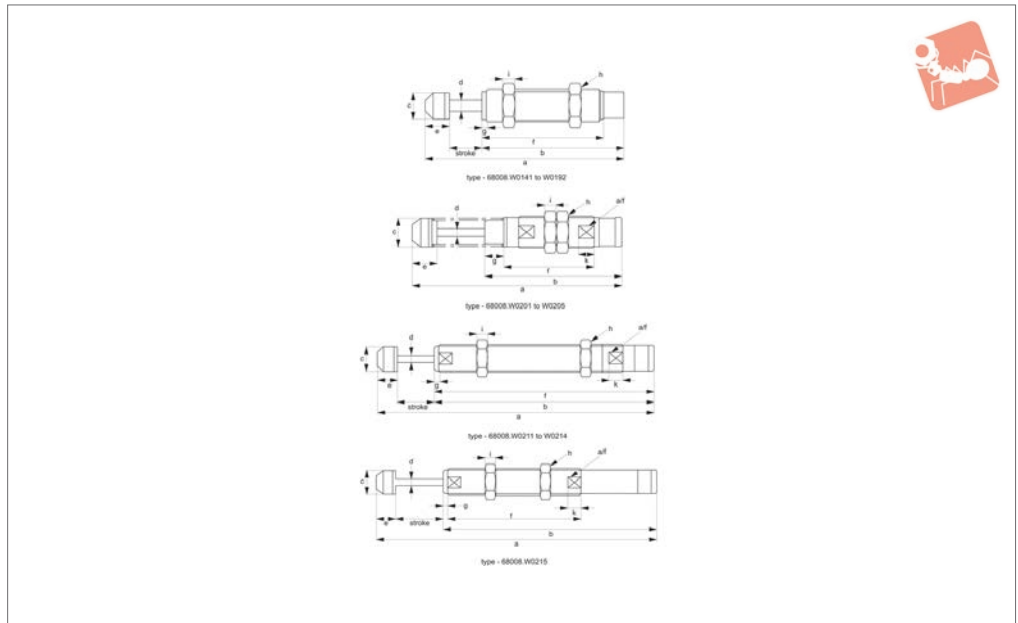

Material

Outer Tube: STKM11A, hardened and blackened.

Piston Rod: AISI 1045 hardened to HV940°, chrome plated.

Return Spring: DIN GWP.

Muffler Cap: urethane rubber. **Seal:** nitrile rubber.

Technical Notes

Supplied with rubber muffler cap as standard, this is removable - see introductory technical notes for guidance.

Tips

Select High Impact Speed model for hard impact at start of stroke. For hard set down

at end of stroke choose a Medium or Low Impact Speed model.

Important Notes

For correct product selection refer to Product Selection Formulae and Calculation pages, and associated Capacity & Selection Charts.

Order No.	Stroke mm	Nm per cycle (Et)		Per hour (ETc)	Effective mass (Me) kg max.	Impact speed (v)	Impact speed (v) m/s max.	Operating temperature °C	Weight g
		Nm max.	Nm max.						
68008.W0141	15	9.8	35280	30	Low	1.0	-10 to +80	80	
68008.W0142	15	9.8	35280	15	Med	1.5	-10 to +80	80	
68008.W0191	20	36.0	22000	27	Low	2.0	-10 to +80	170	
68008.W0192	25	40.0	24200	35	Low	2.0	-10 to +80	180	
68008.W0201	30	44.0	26460	60	V Low	1.2	-10 to +80	185	
68008.W0202	30	44.0	26460	30	Low	1.7	-10 to +80	185	
68008.W0203	30	44.0	26460	15	Med	2.4	-10 to +80	185	
68008.W0204	30	44.0	26460	5	High	4.2	-10 to +80	205	
68008.W0205	30	44.0	26460	3	V High	6.0	-10 to +80	205	
68008.W0211	50	59.0	35280	30	V Low	2.0	-10 to +80	250	
68008.W0213	50	59.0	35280	8	Low	3.8	-10 to +80	250	
68008.W0212	50	59.0	35280	15	Med	2.8	-10 to +80	250	
68008.W0214	50	59.0	35280	5	High	5.0	-10 to +80	250	
68008.W0215	50	59.0	35280	3	V High	6.8	-10 to +80	235	

Order No.	Thread	a	b	c	d	e	f	h	g	i	A/F	k
68008.W0141	M14x1,0	95.2	69.2	12	4	11.0	53.0	19	2.0	5	-	-
68008.W0142	M14x1,0	95.2	69.2	12	4	11.0	53.0	19	2.0	5	-	-
68008.W0191	M20x1,5	129.3	95.0	18	5	15.8	74.5	26	3.8	7	-	-
68008.W0192	M20x1,5	140.4	100.0	18	5	15.8	81.0	26	2.7	7	-	-
68008.W0201	M20x1,5	134.0	85.6	18	5	18.0	48.0	26	21.0	7	18.2	10
68008.W0202	M20x1,5	134.0	85.6	18	5	18.0	48.0	26	21.0	7	18.2	10
68008.W0203	M20x1,5	134.0	85.6	18	5	18.0	48.0	26	21.0	7	18.2	10
68008.W0204	M20x1,5	146.0	97.3	18	5	18.0	48.0	26	32.7	7	18.2	10
68008.W0205	M20x1,5	146.0	97.3	18	5	18.0	48.0	26	32.7	7	18.2	10
68008.W0211	M20x1,5	221.0	156.0	18	5	15.8	136.5	26	4.0	7	18.2	10
68008.W0213	M20x1,5	221.0	156.0	18	5	15.8	136.5	26	4.0	7	18.2	10



Shock Absorbers, Self Compensating

M14 - M20, non-adjustable

Shock Absorbers

Order No.	Thread	a	b	c	d	e	f	h	g	i	A/F	k
68008.W0212	M20x1,5	221.0	156.0	18	5	15.8	136.5	26	4.0	7	18.2	10
68008.W0214	M20x1,5	221.0	156.0	18	5	15.8	136.5	26	4.0	7	18.2	10
68008.W0215	M20x1,5	221.0	156.0	18	5	15.8	60.0	26	4.0	7	18.2	10



SHOCK ABSORBERS



68012

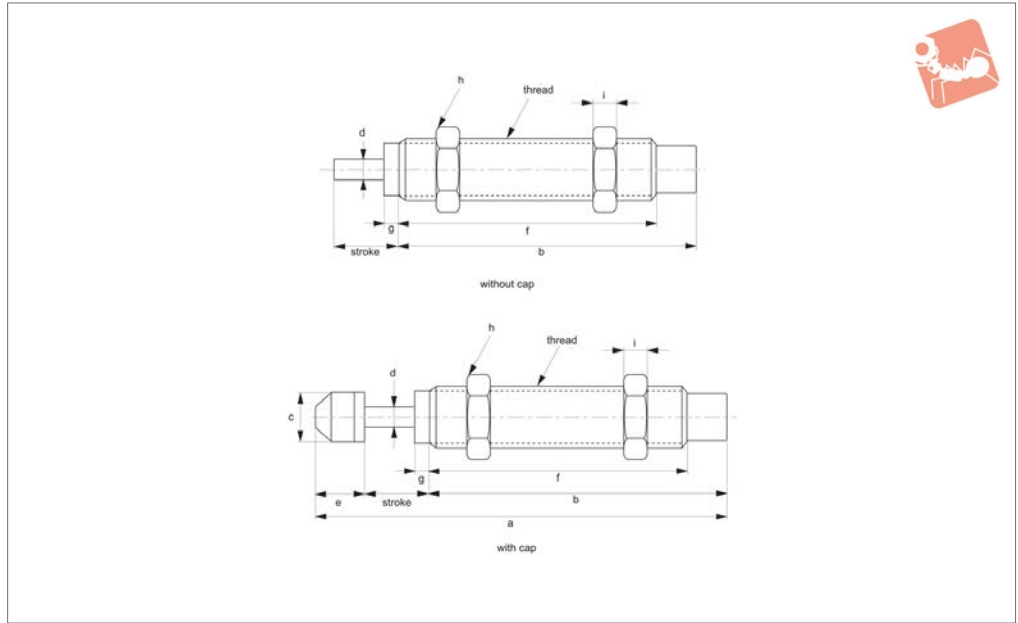

Material

Outer Tube: STKM11A, hardened and blackened.

Piston Rod: AISI 1045 hardened to HV940°, chrome plated.

Return Spring: DIN GWP.

Muffler Cap: urethane rubber. Seal: nitrile

rubber.

Technical Notes

Supplied with rubber muffler cap as standard, this is removable - see introductory technical notes for guidance.

Important Notes

For correct product selection refer to Product Selection Formulae and Calculation pages, and associated Capacity & Selection Charts.

Order No.	With / without cap	Stroke mm	Nm per cycle (Et)		Per hour (ETc)		Effective mass (Me) kg max.	Impact speed (v) m/s max.	Operating temperature °C	Weight g
			Nm max.	Nm max.	Nm max.	Nm max.				
68012.W0080	Without	4	0.5	720	3.0	0,3 - 1,0	-10 to +80	4.0		
68012.W0081	Without	6	3	7000	6	0,3 - 2,5	-10 to +80	15		
68012.W0082	With	6	3	7000	6	0,3 - 2,5	-10 to +80	17		
68012.W0101	Without	7	6	12400	12	0,3 - 2,5	-10 to +80	25		
68012.W0102	With	7	6	12400	12	0,3 - 3,5	-10 to +80	28		
68012.W0121	Without	10	12	22500	22	0,3 - 4,0	-10 to +80	29		
68012.W0122	With	10	12	22500	22	0,3 - 4,0	-10 to +80	32		
68012.W0141	Without	12	20	33000	40	0,3 - 5,0	-10 to +80	65		
68012.W0142	With	12	20	33000	40	0,3 - 5,0	-10 to +80	70		
68012.W0143	With	12	14	24000	25.0	0,3 - 5,0	-10 to +80	70		
68012.W0201	Without	15	59	38000	120	0,3 - 5,0	-10 to +80	150		
68012.W0202	With	15	59	38000	120	0,3 - 5,0	-10 to +80	160		
68012.W0251	Without	25	80	60000	180	0,3 - 5,0	-10 to +80	280		
68012.W0252	With	25	80	60000	180	0,3 - 5,0	-10 to +80	295		
68012.W0271	Without	25	147	72000	270	0,3 - 5,0	-10 to +80	360		
68012.W0272	With	25	147	72000	270	0,3 - 5,0	-10 to +80	375		

Order No.	Thread	a	b	c	d	e	f	h	g	i	A/F
68012.W0080	M 6x0,75	36.5	28.5	4.5	1.8	4.0	22.5	8.0	1	3.0	-
68012.W0081	M 8x1,0	-	40.6	-	2.9	-	33.6	11.0	2	3	-
68012.W0082	M 8x1,0	55.2	40.6	6.6	2.9	8.6	33.6	11.0	2	3	-
68012.W0101	M10x1,0	-	47.0	-	3.0	-	39.0	12.7	3	3	-
68012.W0102	M10x1,0	62.6	47.0	8.6	3.0	8.6	39.0	12.7	3	3	-
68012.W0121	M12x1,0	-	52.5	-	3.0	-	44.0	14.0	3	4	-
68012.W0122	M12x1,0	71.1	52.5	10.3	3.0	8.6	44.0	14.0	3	4	-
68012.W0141	M14x1,5	-	67.0	-	4.0	-	58.0	19.0	4	5	12.1
68012.W0142	M14x1,5	90.0	67.0	12.0	4.0	11.0	58.0	19.0	4	5	12.1
68012.W0143	M14x1,5	78.8	55.0	12.0	4.0	11.2	46.5	19.0	3.5	5.0	12.1



Shock Absorbers, Self Compensating

M8 - M27, non-adjustable

Shock Absorbers

Order No.	Thread	a	b	c	d	e	f	h	g	i	A/F
68012.W0201	M20x1,5	-	73.0	-	6.0	-	62.0	26.0	4	7	18.0
68012.W0202	M20x1,5	103.0	73.0	18.0	6.0	15.0	62.0	26.0	4	7	18.0
68012.W0251	M25x1,5	-	92.0	-	8.0	-	82.0	32.0	-	9	23.0
68012.W0252	M25x1,5	136.0	92.0	22.0	8.0	19.0	82.0	32.0	-	9	23.0
68012.W0271	M27x1,5	-	99.0	-	8.0	-	86.0	36.0	5	6	25.0
68012.W0272	M27x1,5	143.0	99.0	22.0	8.0	19.0	86.0	36.0	5	6	25.0

application examples:

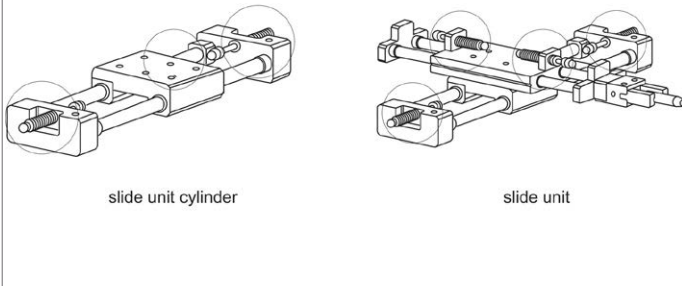



Shock Absorbers benefits and features

Why do we need shock absorbers?

Shock Absorbers are widely used in industry where the speed, direction or movement of objects must be changed or stopped. Without suitable methods of control the kinetic energy inherent in many moving objects, which occur in manufacturing, can result in increased machine wear and even machine damage.

Ideally any method of "shock absorption" should provide two key features:

- 1) Bring the moving object to rest quickly, smoothly and without rebounding forces
- 2) In-built reliability and safety

Shock Absorbers are able to quickly convert the kinetic energy of a moving object into heat and to dissipate this into the air, and provide a constant linear deceleration of an object throughout its entire impact stroke, to quickly, smoothly and quietly bring a moving object to rest with the lowest reaction force and in the shortest time. All of these features mean increased manufacturing productivity, extended machine life, and improved efficiency.

The cost of outdated buffering methods

Traditional buffering methods:

- Springs
- Dash Pots
- Air Buffers
- Rubber bumpers

Costs associated with outdated cushioning methods:

- Loss of production
- Increased machine wear and tear
- Increased maintenance cost
- Increased vibration and noise pollution
- Varying and inconsistent dampening forces, with non-linear or high peak forces at some point in their stroke.

Traditional buffering methods can only dissipate a small percentage of the kinetic energy of a moving object, the remainder is stored (rather than dissipated) as elastic energy which results in high resistance and rebounding forces toward the end of the impact stroke.

Benefits of using Wixroyd Shock Absorbers

Wixroyd Shock Absorbers are designed to stop a moving object smoothly and quietly from the beginning to the end of its impact stroke. Their design enables a constant resistance force or linear deceleration throughout the impact stroke, quickly converting the kinetic energy of the moving object into heat which is quickly dissipated into the air. A linear deceleration curve, as achieved by our shock absorbers, brings an object to rest in the shortest time while reducing damaging impact forces.

Energy Capacity: Shock absorbers can absorb more energy, without increasing deceleration or reaction forces.

Stopping Force: Shock absorbers provide smooth deceleration of parts, which means less machine wear and hence reduced maintenance.

Stopping time: Shock absorbers bring moving loads to rest more quickly, increasing productivity.

Advantages of using Wixroyd Shock Absorbers

- Consistent and reliable dampening force or linear deceleration, throughout entire impact stroke
- Smoother motion and deceleration of moving parts
- Increased productivity
- Extended machine life and improved efficiency
- Simplified application design and build costs
- Reduced maintenance costs
- Improved health and safety, through reduced vibration and noise pollution

Comparison of shock absorbers vs. other methods

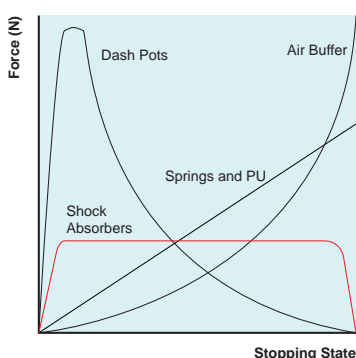

Dashpots: produce large peak forces at beginning of impact stroke, abruptly slowing load - however braking force quickly declines.

Springs & Rubber Buffers: energy is stored rather than dissipated, resulting in rebounding of the load.

Air Buffers: initial braking force is low, but due to the compressibility of air it increases sharply toward later stages of stroke, resulting in inconsistent braking force.

Shock Absorbers: designed to stop a moving object smoothly and quietly from beginning to end of its impact stroke. Their design enables constant resistance force or linear deceleration throughout impact stroke, they quickly convert kinetic energy of a moving object into heat which is quickly dissipated into the air.



Wixroyd Shock Absorbers are available in two primary types



Self-compensating

Self compensating shock absorber 68001

Our Self-Compensating Shock Absorbers are effective for a stated range of Effective Mass (Me), and are self-compensating within this range - see selection charts. As long as the applications effective mass remains within the given range then no additional adjustment is required for changes in weight, speed or propelling force.

See models: 68001, 68002, 68003, 68004, 68008, 68012

Self compensating shock absorber 68002

Each Self-Compensating Shock Absorber is available in three standard max. Impact speed (v-m/s) variations:

- 1 - high impact speed
- 2 - medium impact speed
- 3 - low impact speed

For specific max. impact speed values please refer to the selections charts and the specific product tables.

For hard impact at the start of a stroke it is advisable to choose a high impact speed model, for hard set down at the end of a stroke it is advisable to choose a medium or low impact speed model, or to move up to the next higher bore size



Adjustable

Adjustable shock absorber 68020

Set collar to 0 at initial installation

After a few cycles adjust collar setting to suit application

Adjustable Shock Absorbers have an adjustment collar at their base (with a scale of 0-9), which enables adjustment of the Shock Absorber's optimum deceleration to suit the application.

After initial installation, the Shock Absorber should be cycled a number of times to settle, and then the adjustable collar turned to the desired position for the application.

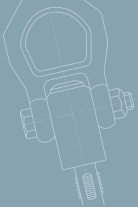

Inside a Wixroyd Shock Absorber

Shock absorber design

The design of Wixroyd Shock Absorbers is beautifully simple and beautifully effective. Made from high quality materials and components, they provide the highest performance and reliability.

SHOCK ABSORBERS

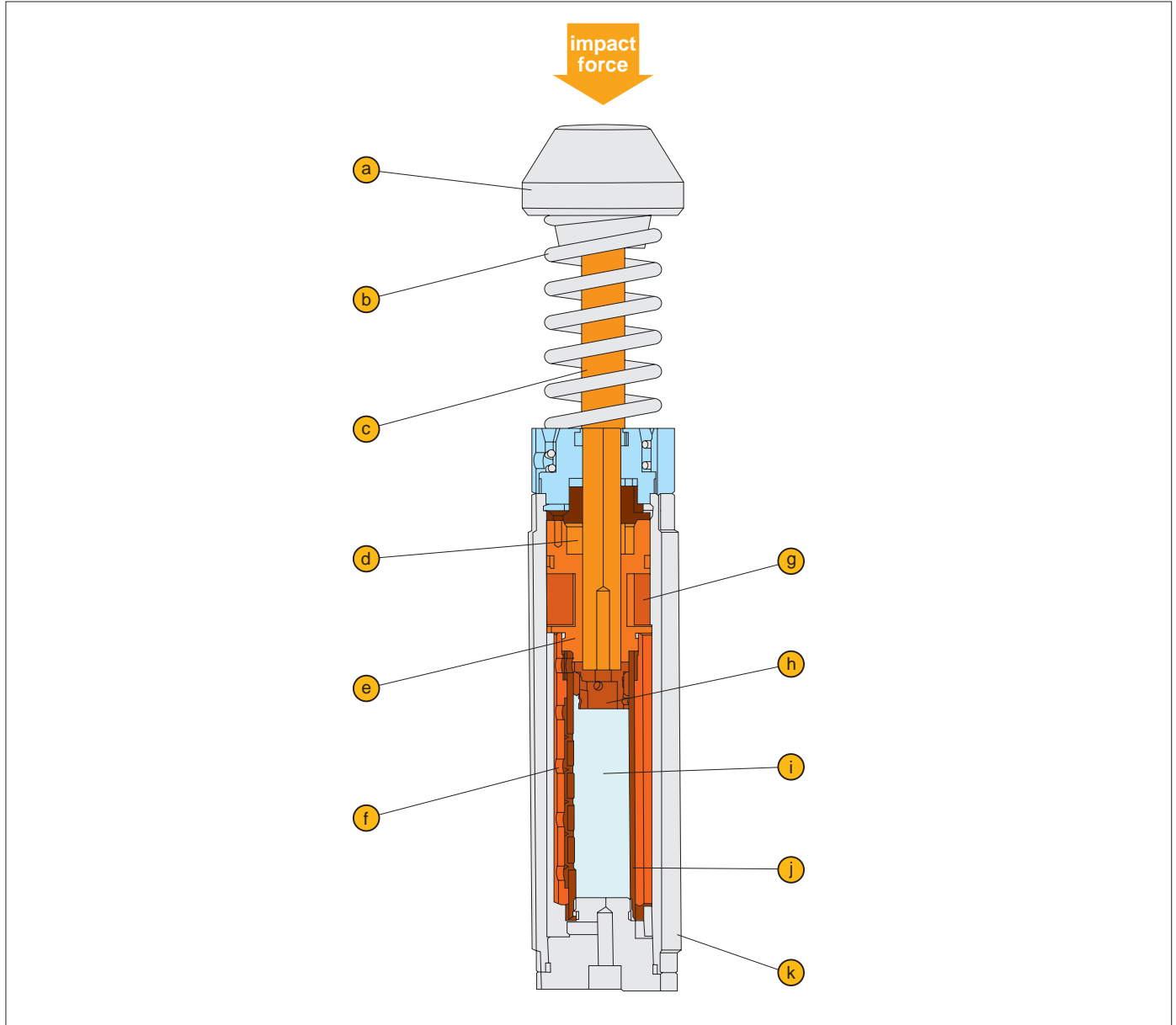

- a** Impact Cap
- b** Return Spring; DIN GWP (external and internal models avai.)
- c** Piston Rod; AISI 1045, hardened to HV940°, chrome plated
- d** Seal
- e** Bearing
- f** Orifices
- g** Accumulator; neoprene rubber
- h** Check Valve
- i** Fluid
- j** Inner Tube
- k** Outer Tube; STKM11A, hardened and blackened

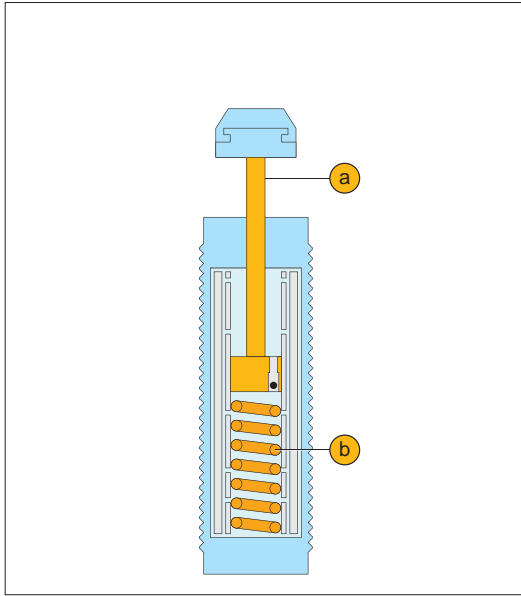

At rest

1) Shock Absorber at rest, piston rod (1), fully extended through force exerted on it by return spring (2).

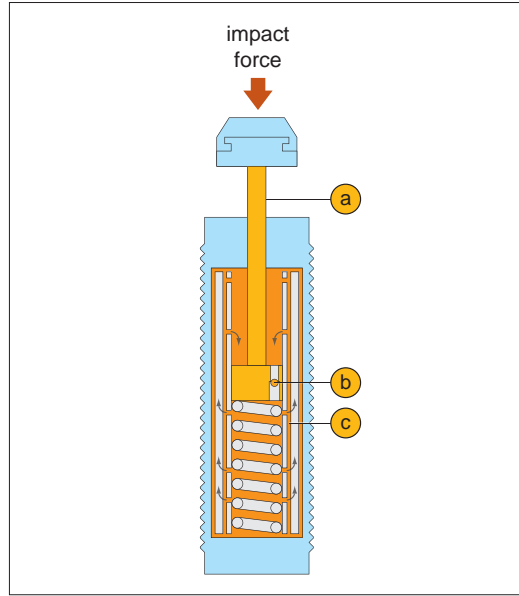

Initial impact

2) Moving load impacts piston (1), which moves into shock absorber body increasing pressure in chamber.
3) Piston rod check valve closes (2). Hydraulic oil behind the piston head is initially able to escape/vent into the accumulator (3).

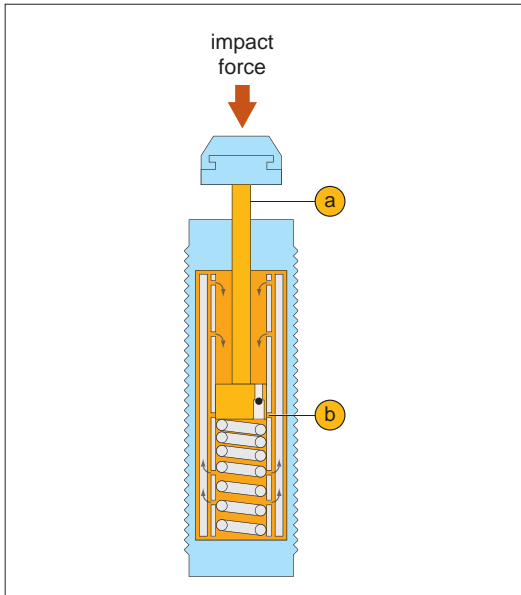

Continued impact and linear deceleration

4) As load on piston rod (1) increases, the rod continues to move back into the inner tube, as it does so the number of available metering orifices (2) through which the hydraulic oil is able to escape reduces - hence the velocity of the moving load continues to decelerate.

5) The number and position of the orifices are such that the pressure in the inner tube remains constant throughout the entire impact stroke - providing constant linear deceleration. (Number of metering orifices decreases proportionally through length of piston rod.)

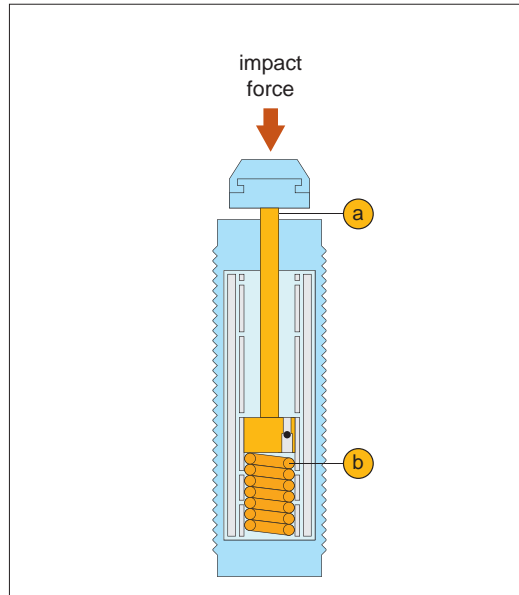

Load brought to rest

6) The moving load is brought to a smooth and quiet stop.
7) When the load is removed the return spring (2) pushes the piston (1), back to its original resting position, ready for the next cycle.

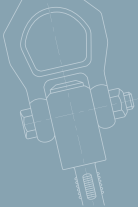

Optional extras

Stop collars

We advise the use of external mechanical stops with all of our Shock Absorbers, typically within 1 to 0.5 mm from the end of the stroke. Alternatively, we have a range of stop collars available which can be mounted directly to the shock absorber body (see our part 68030). Stop Collars are available for our M8 to M36 threaded models, they can be used both to adjust stroke and also to fix the end position of the load.

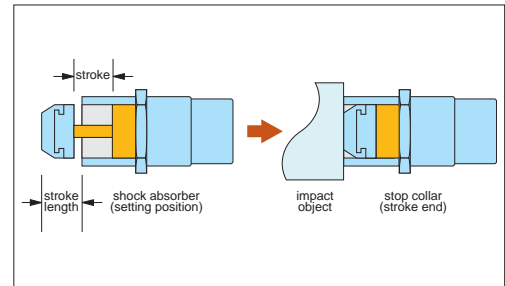

Flange mounting adaptors

Basic mounting of shock absorbers is through the use of its threaded body, and lock nuts supplied. Alternatively Shock Absorbers can be flange mounted, please see our available flange mounting adaptors part 68032 for our M36 and M42 threaded models.

Muffler caps

Shock Absorbers are supplied with muffler caps as standard. Muffler caps can be removed from the Shock Absorber Piston by heating them with a lighter and pulling away using a pair of pliers.

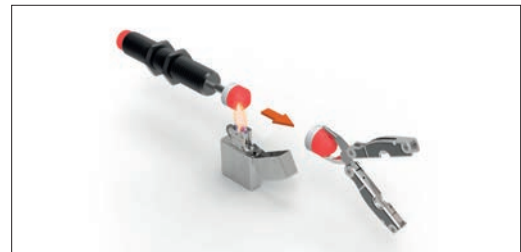

Application examples

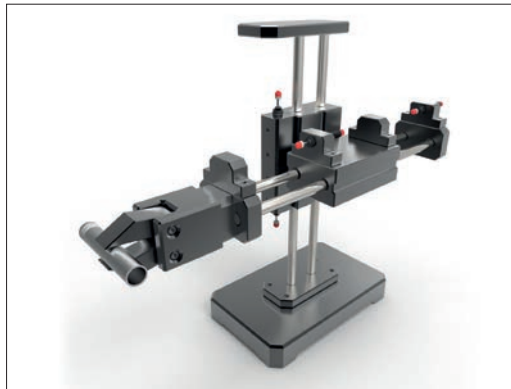

Pick and place robots

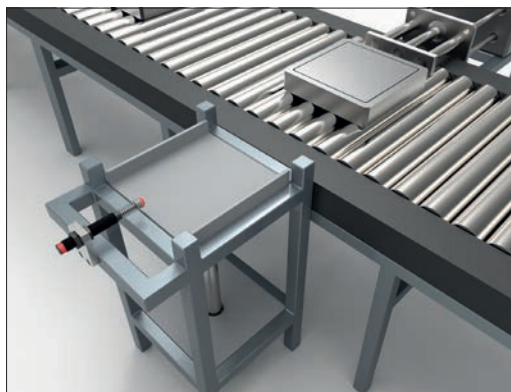
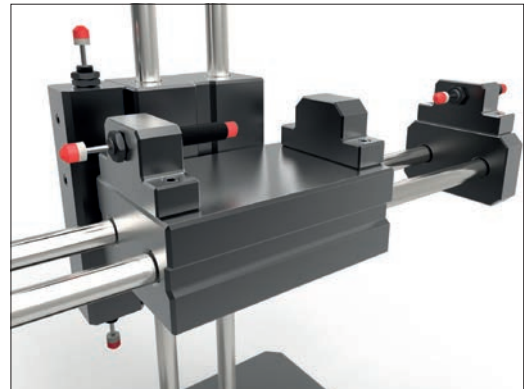

Pick and place machines

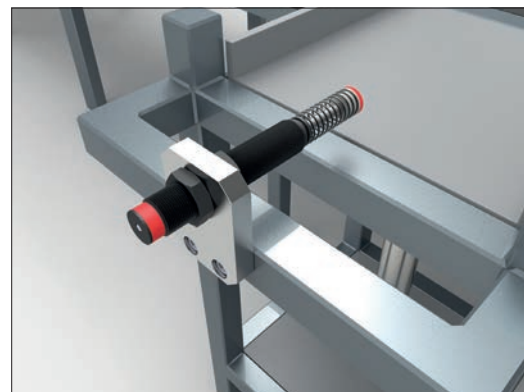

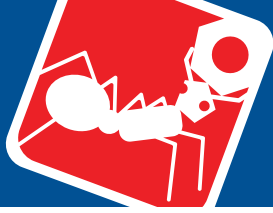

How to select your Wixroyd Shock Absorber

- 1) Direction of movement - horizontal, free fall or rotary
- 2) Total weight of impacting object
- 3) Propelling force - if present

- 4) Impact velocity of load
- 5) Number of cycles/impact per hour
- 6) Number of shock absorbers in application (only if parallel)

Firstly consider the following:

- 1) Mass to be decelerated (weight) m (kg)
- 2) Impact velocity at shock absorber ..v (m/s)
- 3) Propelling or driving force..... F (N)

- 4) Number of impact cycles per hour... C (/hr)
- 5) Desired shock absorber stroke S (m)

Secondly, ascertain the following from your application

ET (Nm) Maximum energy absorbed per cycle
 ETC (Nm/hr) Maximum energy absorbed per hour
 Me (Kg) Effective mass

Thirdly, derive value for the following within your application

Formulae on the following pages will allow you to derive these values for the most appropriate set-up of your application.

Using the values derived from you calculations, refer to our selection charts and identify the most suitable Wixroyd Shock Absorber for your application.

Finally, refer to our selection charts

Mounting and installation information

1. Please install a 1 to 0.5 mm mechanical stop or stop collar before the end of the impact stroke and do not drive shock absorbers into their final position under full load. See the range of Stop Collars part 68030, which can be easily mounted on to shock absorbers to protect shock absorber pistons from bottoming out and can also be used to adjust the final stroke.
2. Reusing is prohibited after dismantling. Do not paint the piston rod or threaded body. This both inhibits movement of the piston and can interfere with effective heat dissipation.
3. Install shock absorbers as close to the moving object's centre as possible.
4. If installing shock absorbers in sheet metal, please ensure sheet metal is robust enough.
5. When installing two or more shock absorbers in parallel, please ensure that they have the same stroke.

Product selection calculation

- 1) Kinetic energy: $E_k = mv^2/2$
- 2) Drive energy: $E_d = F \cdot S$
- 3) Free fall velocity: $v = \sqrt{2g \cdot h}$
- 4) Pneumatic or hydraulic cylinder driving forces: $F = 0.00785 Pd^2$
- 5) Maximum shock force (approximate): $F_m = 1.2 E_T/S$
- 6) Propelling force generated by electric motors: $F = 3000 kW/v$
- 7) Total energy absorbed per hour: $E_{TC} = E_T \cdot C$

Some useful calculation formulae

μ	-	coefficient of friction	E_{TC}	(Nm)	total energy per hour	M_e	(kg)	effective mass	Key to formulae symbols used
α	(rad)	angle of incline	F	(N)	propelling force	P	(Bar)	operation pressure	
θ	(rad)	side load of angle	F_m	(N)	maximum shock force	R	(m)	radius	
ω	(rad/s)	angular velocity	g	(m/s ²)	acceleration due to gravity (9.81m/s ²)	R_s	(m)	shock absorber mounting distance from rotation center	
A	(m)	width	h	(m)	height	S	(m)	stroke	
B	(m)	thickness	I	(Nm/s ²)	moment of inertia	T	(Nm)	driving torque	
C	(/hr)	impact cycles per hour	-	-	arresting torque factor for motors (normally 2.5)	t	(s)	decelartion time	
d	(mm)	cylinder bore diameter	HM	-	arresting torque factor for motors (normally 2.5)	v	(m/s)	velocity of impact mass	
E_d	(Nm)	drive energy per cycle	kW	(kW)	electric motor power	v_s	(m/s)	impact velocity at shock absorber	
E_k	(Nm)	kinetic energy per cycle	m	(kg)	mass to be decelerated				

ov-W68001-A-T-W68032-A-T-F-rnh-- Updated -3 1-10-2022

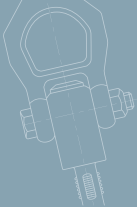

1) Horizontal moving mass - without propelling force

$m = 300\text{kg}$
 $v = 1,0\text{m/s}$
 $S = 0,04\text{m}$
 $C = 300/\text{hr}$

$$E_k = \frac{mv^2}{2} = \frac{300 \cdot 1,0^2}{2} = 150\text{Nm}$$

$$E_T = E_k = 150\text{Nm}$$

$$E_{TC} = E_T \cdot C = 150 \cdot 300 = 45000\text{Nm/hr}$$

$$M_e = \frac{2E_T}{v^2} = \frac{2 \cdot 150}{1,0^2} = 300\text{kg}$$

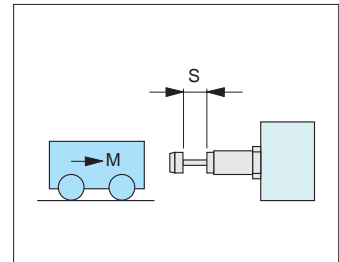

Selection from capacity chart: 68024.W0362 is suitable

2) Horizontal moving mass - with propelling force

$m = 300\text{kg}$
 $v = 1,2\text{m/s}$
 $S = 0,05\text{m}$
 $P = 40\text{N/cm}^2$
 $d = 100\text{mm}$
 $C = 300/\text{hr}$

$$E_k = \frac{mv^2}{2} = \frac{300 \cdot 1,2^2}{2} = 216\text{Nm}$$

$$E_D = F \cdot S = 0,00785Pd^2 \cdot S = 0,00785 \cdot 40 \cdot 100^2 \cdot 0,05 = 157\text{Nm}$$

$$E_T = E_k + E_D = 216 + 157 = 373\text{Nm}$$

$$E_{TC} = E_T \cdot C = 373 \cdot 300 = 111900\text{Nm/hr}$$

$$M_e = \frac{2E_T}{v^2} = \frac{2 \cdot 373}{1,2^2} = 518\text{kg}$$

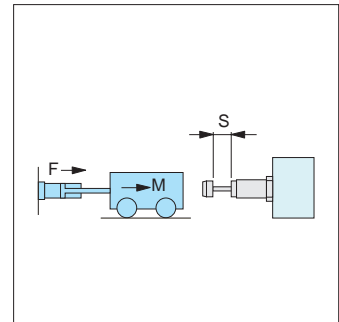

Selection from capacity chart: 68024.W0422 is suitable

3) Horizontal moving mass - motor driven

$m = 400\text{kg}$
 $v = 1,0\text{m/s}$
 $\text{kW} = 1,5\text{kW}$
 $\text{HM} = 2,5$
 $S = 0,075\text{m}$
 $C = 60/\text{hr}$

$$E_k = \frac{mv^2}{2} = \frac{400 \cdot 1,0^2}{2} = 200\text{Nm}$$

$$E_D = F \cdot S = \frac{\text{kW} \cdot \text{HM}}{v} \cdot S = \frac{1500 \cdot 2,5}{1,0} \cdot 0,075 = 281\text{Nm}$$

$$E_T = E_k + E_D = 200 + 281 = 481\text{Nm}$$

$$E_{TC} = E_T \cdot C = 481 \cdot 60 = 25860\text{Nm/hr}$$

$$M_e = \frac{2E_T}{v^2} = \frac{2 \cdot 481}{1,0^2} = 962\text{kg}$$

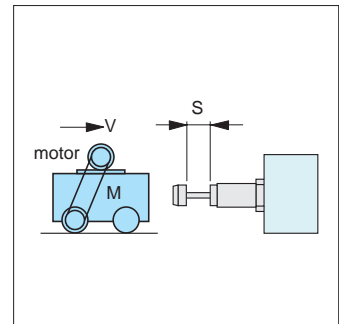

Selection from capacity chart: 68024.W0423 is suitable

4) Horizontal moving mass - driven rollers

$m = 150\text{kg}$
 $v = 0,5\text{m/s}$
 $\mu = 0,25$
 $S = 0,02\text{m}$
 $C = 120/\text{hr}$

$$E_k = \frac{mv^2}{2} = \frac{150 \cdot 0,5^2}{2} = 18,75\text{Nm}$$

$$E_D = F \cdot S = mg\mu \cdot S = 150 \cdot 9,81 \cdot 0,25 \cdot 0,02 = 7,35\text{Nm}$$

$$E_T = E_k + E_D = 18,75 + 7,35 = 26,1\text{Nm}$$

$$E_{TC} = E_T \cdot C = 26,1 \cdot 120 = 3132\text{Nm/hr}$$

$$M_e = \frac{2E_T}{v^2} = \frac{2 \cdot 26,1}{0,5^2} = 208,8\text{kg}$$

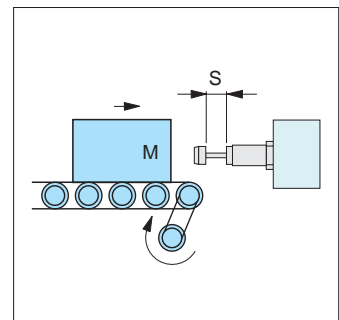

Selection from capacity chart: 68002.W0203 is suitable

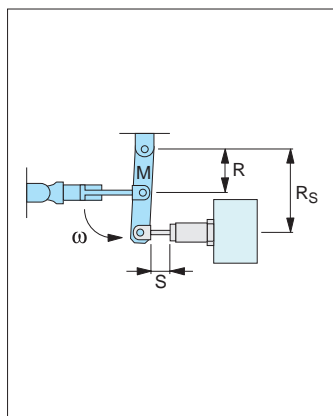
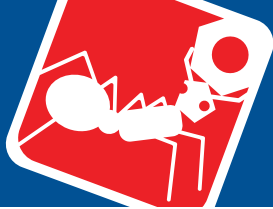

$$E_k = \frac{I \cdot \omega^2}{2} = \frac{216 \cdot 3^2}{2} = 972 \text{ Nm}$$

$$F = \frac{0,0785 \cdot D^2 \cdot P \cdot R}{R_s} = \frac{0,0785 \cdot 80^2 \cdot 5 \cdot 0,6}{0,9} = 1674,7 \text{ Nm}$$

$$E_D = F \cdot S = 1674,7 \cdot 0,05 = 83,7 \text{ Nm}$$

$$E_T = E_k + E_D = 972 + 83,7 = 1055,7 \text{ Nm}$$

$$E_{TC} = E_T \cdot C = 1055,7 \cdot 150 = 158355 \text{ Nm/hr}$$

$$v = R_s \cdot \omega = 0,6 \cdot 3 = 1,8 \text{ m/s}$$

$$M_e = \frac{2E_T}{v^2} = \frac{2 \cdot 1055,7}{1,8^2} = 651,2 \text{ kg}$$

5) Swinging arm - with propelling force (universal weight distribution)

$P = 5 \text{ bar}$
 $m = 600 \text{ kg}$
 $\omega = 3 \text{ rad/s}$
 $R = 0,6 \text{ m}$
 $R_s = 0,9 \text{ m}$
 $d = 80 \text{ mm}$
 $C = 150 \text{ /hr}$
 $I = 216 \text{ Nm/s}^2$

Selection from capacity chart: 68002.W0203 is suitable

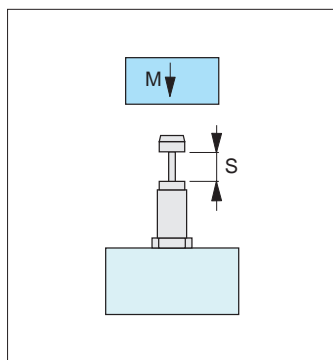

$$v = \sqrt{2g \cdot h} = \sqrt{2 \cdot 9,81 \cdot 0,4} = 2,8 \text{ m/s}$$

$$E_k = \frac{mv^2}{2} = \frac{40 \cdot 2,8^2}{2} = 157 \text{ Nm}$$

$$E_D = F \cdot S = mg \cdot h = 40 \cdot 9,81 \cdot 0,06 = 23,5 \text{ Nm}$$

$$E_T = E_k + E_D = 157 + 23,5 = 180,5 \text{ Nm}$$

$$E_{TC} = E_T \cdot C = 180,5 \cdot 200 = 36100 \text{ Nm/hr}$$

$$M_e = \frac{2E_T}{v^2} = \frac{2 \cdot 180,5}{2,8^2} = 46 \text{ kg}$$

6) Vertical moving mass - free falling

$m = 40 \text{ kg}$
 $h = 0,4 \text{ m}$
 $S = 0,06 \text{ m}$
 $C = 200 \text{ /hr}$

Selection from capacity chart: 68003.W0361 is suitable

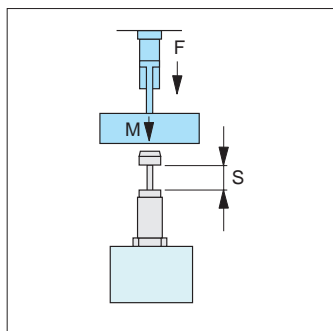

$$E_k = \frac{mv^2}{2} = \frac{40 \cdot 1,0^2}{2} = 20 \text{ Nm}$$

$$E_D = F \cdot S = (mg + 0,0785Pd^2) \cdot S = (40 \cdot 9,81 + 0,0785 \cdot 5 \cdot 50^2) \cdot 0,025 = 33,5 \text{ Nm}$$

$$E_T = E_k + E_D = 20 + 33,5 = 55,5 \text{ Nm}$$

$$E_{TC} = E_T \cdot C = 55,5 \cdot 200 = 11100 \text{ Nm/hr}$$

$$M_e = \frac{2E_T}{v^2} = \frac{2 \cdot 55,5}{1,0^2} = 111 \text{ kg}$$

7) Vertical moving mass - with propelling force

$m = 40 \text{ kg}$
 $h = 0,3 \text{ m}$
 $S = 0,025 \text{ m}$
 $P = 5 \text{ bar}$
 $d = 50 \text{ mm}$
 $C = 200 \text{ /hr}$
 $v = 1,0 \text{ m/s}$

Selection from capacity chart: 68024.W0252 is suitable

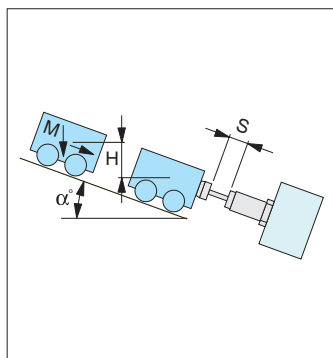

$$v = \sqrt{2g \cdot h} = \sqrt{2 \cdot 9,81 \cdot 0,3} = 2,43 \text{ m/s}$$

$$E_k = \frac{mv^2}{2} = \frac{150 \cdot 2,43^2}{2} = 443 \text{ Nm}$$

$$E_D = F \cdot S = m \cdot g \cdot S \cdot \sin \alpha = 150 \cdot 9,81 \cdot 0,075 \cdot \sin 30^\circ = 55,2 \text{ Nm}$$

$$E_T = E_k + E_D = 443 + 55,2 = 498,2 \text{ Nm}$$

$$E_{TC} = E_T \cdot C = 498,2 \cdot 200 = 99640 \text{ Nm/hr}$$

$$M_e = \frac{2E_T}{v^2} = \frac{2 \cdot 498,2}{2,43^2} = 168,7 \text{ kg}$$

8) Free moving mass - on inclined plane

$m = 150 \text{ kg}$
 $h = 0,3 \text{ m}$
 $\alpha = 30^\circ$
 $S = 0,075 \text{ m}$
 $C = 200 \text{ /hr}$

Selection from capacity chart: 68024.W0423 is suitable

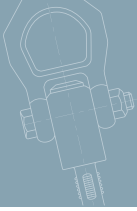

9) Horizontal rotating door

- m = 20kg
- $\omega = 2,0\text{rad/s}$
- T = 20Nm
- $R_s = 0,8\text{m}$
- A = 1,0m
- B = 0,05m
- S = 0,016m
- C = 100/hr

$$I = \frac{m(4A^2 + B^2)}{12} = \frac{20(4 \cdot 1,0^2 + 0,05^2)}{12} = 6,67\text{kg} \cdot \text{m}^2$$

$$E_k = \frac{I^2}{2} = \frac{6,67 \cdot 2,0^2}{2} = 13,34\text{Nm}$$

$$= \frac{S}{R_s} = \frac{0,04}{0,8} = 0,05\text{rad}$$

$$E_D = T \cdot = 20 \cdot 0,5 = 1,0\text{Nm}$$

$$E_T = E_k + E_D = 13,34 + 1,0 = 14,34\text{Nm}$$

$$E_{TC} = E_T \cdot C = 14,34 \cdot 100 = 1434\text{Nm/hr}$$

$$v = \cdot R_s = 2,0 \cdot 0,8 = 1,6\text{m/s}$$

$$M_e = \frac{2E_T}{v^2} = \frac{2 \cdot 14,34}{1,6^2} = 11,2\text{kg}$$

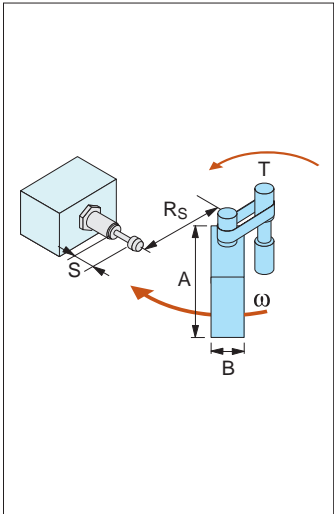

Selection from capacity chart: 68002.W0203 is suitable

10) Horizontal rotating mass - with torque

- m = 40kg
- A = 0,5m
- B = 0,05m
- $\omega = 2,0\text{rad/s}$
- T = 10Nm
- $R_s = 0,4\text{m}$
- S = 0,05m
- C = 50/hr

$$I = \frac{m(4A^2 + B^2)}{12} = \frac{40(4 \cdot 0,5^2 + 0,05^2)}{12} = 3,36\text{kg} \cdot \text{m}^2$$

$$E_k = \frac{I^2}{2} = \frac{3,36 \cdot 2,0^2}{2} = 6,8\text{Nm}$$

$$= \frac{S}{R_s} = \frac{0,05}{0,4} = 0,125\text{rad}$$

$$E_D = T \cdot = 10 \cdot 0,125 = 1,25\text{Nm}$$

$$E_T = E_k + E_D = 6,8 + 1,25 = 8,05\text{Nm}$$

$$E_{TC} = E_T \cdot C = 8,05 \cdot 50 = 402,5\text{Nm/hr}$$

$$v = \cdot R_s = 2,0 \cdot 0,4 = 0,8\text{m/s}$$

$$M_e = \frac{2E_T}{v^2} = \frac{2 \cdot 8,05}{0,8^2} = 25,15\text{kg}$$

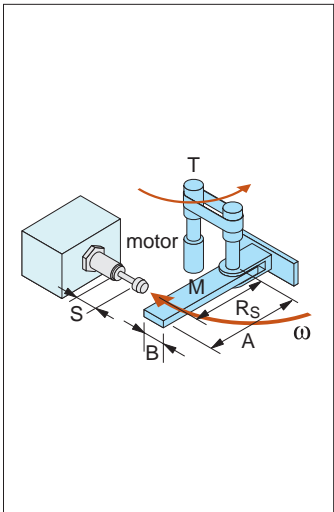

Selection from capacity chart: 68003.W0361 is suitable

11) Rotary index table - with propelling force

- m = 200kg
- $\omega = 1,0\text{rad/s}$
- T = 100Nm
- R = 0,5m
- $R_s = 0,4\text{m}$
- S = 0,04m
- C = 100/hr

$$I = \frac{mR^2}{2} = \frac{200 \cdot 0,5^2}{2} = 25\text{kg} \cdot \text{m}^2$$

$$E_k = \frac{I^2}{2} = \frac{25 \cdot 1,0^2}{2} = 12,5\text{Nm}$$

$$= \frac{S}{R_s} = \frac{0,04}{0,4} = 0,1\text{rad}$$

$$E_D = T \cdot = 100 \cdot 0,1 = 10\text{Nm}$$

$$E_T = E_k + E_D = 12,5 + 10 = 22,5\text{Nm}$$

$$E_{TC} = E_T \cdot C = 22,5 \cdot 50 = 1125\text{Nm/hr}$$

$$v = \cdot R_s = 1,0 \cdot 0,4 = 0,4\text{m/s}$$

$$M_e = \frac{2E_T}{v^2} = \frac{2 \cdot 22,5}{0,4^2} = 281\text{kg}$$

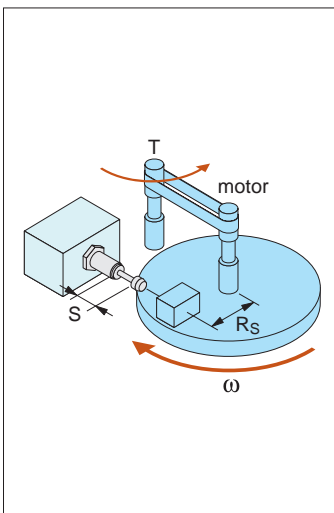

Selection from capacity chart: 68024.W0255 is suitable



68001 - shock absorbers - self compensating

Order Number	Stroke (mm)	Thread (mm)	Max. Energy per cycle Nm (ET)	Max. Energy per hour Nm/hr (ETC)	Max. Effective Mass Kg (Me)	Max. Impact Speed m/s (v)	Operating temp. (°C)	Avai. w/o cap	Avai. with cap	Flange Avai.	Stop Collar Avai.	Weight (g)
68001.W0081	6	M 8 x 1,0	2	8,800	0,5	2,0	-10~+80	•	•	-	•	11
68001.W0082	6	M 8 x 1,0	2	8,800	2,0	1,0	-10~+80	•	•	-	•	11
68001.W0083	6	M 8 x 1,0	2	8,800	6,0	0,5	-10~+80	•	•	-	•	11
68001.W0101	5	M10 x 1,0	3	10,800	1,0	3,0	-10~+80	•	•	-	•	14
68001.W0102	5	M10 x 1,0	3	10,800	3,0	1,5	-10~+80	•	•	-	•	14
68001.W0103	5	M10 x 1,0	3	10,800	7,0	0,8	-10~+80	•	•	-	•	14
68001.W0104	8	M10 x 1,0	4	15,200	2,0	3,0	-10~+80	•	•	-	•	20
68001.W0105	8	M10 x 1,0	4	15,200	4,0	1,5	-10~+80	•	•	-	•	20
68001.W0106	8	M10 x 1,0	4	15,200	9,0	0,8	-10~+80	•	•	-	•	20
68001.W0107	10	M10 x 0,75	4	10,800	1,0	3,0	-10~+80	•	•	-	•	20
68001.W0108	10	M10 x 0,75	4	10,800	2,0	1,0	-10~+80	•	•	-	•	20
68001.W0109	10	M10 x 0,75	4	10,800	3,0	0,5	-10~+80	•	•	-	•	20
68001.W0121	10	M12 x 1,0	5	17,640	5,0	3,0	-10~+80	•	•	-	•	32
68001.W0122	10	M12 x 1,0	5	17,640	10,0	1,5	-10~+80	•	•	-	•	32
68001.W0123	10	M12 x 1,0	5	17,640	30,0	0,8	-10~+80	•	•	-	•	32

68002, 68004 - shock absorbers - self compensating

Order Number	Stroke (mm)	Thread (mm)	Max. Energy per cycle Nm (ET)	Max. Energy per hour Nm/hr (ETC)	Max Effective Mass Kg (Me)	Max. Impact Speed m/s (v)	Operating temp. (°C)	Avai. w/o cap	Avai. with cap	Flange Avai.	Stop Collar Avai.	Weight (g)
68002.W0141	12	M14 x 1,5	15	30,000	8	3,0	-10~+80	•	•	-	•	80
68002.W0142	12	M14 x 1,5	15	30,000	50	1,5	-10~+80	•	•	-	•	80
68002.W0143	12	M14 x 1,5	15	30,000	100	0,8	-10~+80	•	•	-	•	80
68002.W0147	16	M14 x 1,5	20	35,000	10	3,0	-10~+80	•	•	-	•	80
68002.W0148	16	M14 x 1,5	20	35,000	70	1,0	-10~+80	•	•	-	•	80
68002.W0149	16	M14 x 1,5	20	35,000	150	0,5	-10~+80	•	•	-	•	80
68002.W0198	20	M14 x 1,5	20	35,000	10	3,0	-10~+80	•	•	-	•	80
68002.W0199	20	M14 x 1,5	20	35,000	70	1,0	-10~+80	•	•	-	•	80
68002.W0200	20	M14 x 1,5	20	35,000	150	0,5	-10~+80	•	•	-	•	80
68002.W0201	20	M20 x 1,5	40	40,000	30	3,5	-10~+80	•	•	-	•	215
68002.W0202	20	M20 x 1,5	40	40,000	200	2,0	-10~+80	•	•	-	•	215
68002.W0203	20	M20 x 1,5	40	40,000	700	1,0	-10~+80	•	•	-	•	215
68002.W0204	30	M20 x 1,5	50	48,000	30	3,5	-10~+80	•	•	-	•	220
68002.W0205	30	M20 x 1,5	50	48,000	200	2,0	-10~+80	•	•	-	•	220
68002.W0206	30	M20 x 1,5	50	48,000	700	1,0	-10~+80	•	•	-	•	220
68002.W0207	50	M20 x 1,5	60	60,000	60	3,5	-10~+80	-	•	-	•	300
68002.W0208	50	M20 x 1,5	60	60,000	400	2,0	-10~+80	-	•	-	•	300
68002.W0209	50	M20 x 1,5	60	60,000	1,200	1,0	-10~+80	-	•	-	•	300
68004.W0201	30	M20 x 1,5	45	55,000	40	3,5	-10~+80	-	•	-	•	220
68004.W0202	30	M20 x 1,5	45	55,000	300	2,0	-10~+80	-	•	-	•	220
68004.W0203	30	M20 x 1,5	45	55,000	900	1,0	-10~+80	-	•	-	•	220
68004.W0204	35	M20 x 1,5	52	63,000	40	3,5	-10~+80	-	•	-	•	210
68004.W0205	35	M20 x 1,5	52	63,000	200	2,0	-10~+80	-	•	-	•	210
68004.W0206	35	M20 x 1,5	52	63,000	650	1,0	-10~+80	-	•	-	•	210
68004.W0207	50	M20 x 1,5	60	68,000	60	3,5	-10~+80	-	•	-	•	470
68004.W0208	50	M20 x 1,5	60	68,000	210	2,0	-10~+80	-	•	-	•	470
68004.W0209	50	M20 x 1,5	60	68,000	480	1,0	-10~+80	-	•	-	•	470

ov-W68001-A-T-W68032-A-T-j-rmh- Updated - 31-10-2022

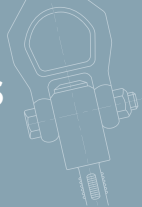

68003 - shock absorbers - self compensating

Order Number	Stroke (mm)	Thread (mm)	Max. Energy per cycle Nm (ET)	Max. Energy per hour Nm/hr (ETC)	Max Effective Mass Kg (Me)	Max. Impact Speed m/s (v)	Operating temp. (°C)	Avai. w/o cap	Avai. with cap	Flange Avai.	Stop Collar Avai.	Weight (g)
68003.W0251	25	M25 x 1,5	80	54,000	200	4,0	-10~+80	•	•	-	•	330
68003.W0252	25	M25 x 1,5	80	54,000	800	2,5	-10~+80	•	•	-	•	330
68003.W0253	25	M25 x 1,5	80	54,000	1,500	1,0	-10~+80	•	•	-	•	330
68003.W0254	40	M25 x 1,5	120	75,000	300	4,0	-10~+80	-	•	-	•	430
68003.W0255	40	M25 x 1,5	120	75,000	1,200	2,5	-10~+80	-	•	-	•	430
68003.W0256	40	M25 x 1,5	120	75,000	2,000	1,0	-10~+80	-	•	-	•	430
68003.W0257	50	M25 x 1,5	98	90,000	15	4,0	-10~+80	•	•	-	•	435
68003.W0258	50	M25 x 1,5	98	90,000	40	2,5	-10~+80	•	•	-	•	435
68003.W0259	50	M25 x 1,5	98	90,000	160	1,0	-10~+80	•	•	-	•	435
68003.W0261	80	M25 x 1,5	150	120,000	20	4,0	-10~+80	•	•	-	•	535
68003.W0262	80	M25 x 1,5	150	120,000	50	2,5	-10~+80	•	•	-	•	535
68003.W0263	80	M25 x 1,5	150	120,000	200	1,0	-10~+80	•	•	-	•	535
68003.W0361	60	M36 x 1,5	250	120,000	400	4,0	-10~+80	-	•	•	•	1030
68003.W0362	60	M36 x 1,5	250	120,000	1,500	2,5	-10~+80	-	•	•	•	1030
68003.W0363	60	M36 x 1,5	250	120,000	2,400	1,0	-10~+80	-	•	•	•	1030

68005 - shock absorbers - self compensating

Order Number	Stroke (mm)	Thread (mm)	Max. Energy per cycle Nm (ET)	Max. Energy per hour Nm/hr (ETC)	Max Effective Mass Kg (Me)	Max. Impact Speed m/s (v)	Operating temp. (°C)	Avai. w/o cap	Avai. with cap	Flange Avai.	Stop Collar Avai.	Weight (g)
68005.W0301	25	M30 x 1,5	180	60,000	300	3,0	-10~+80	-	•	-	•	950
68005.W0302	25	M30 x 1,5	180	60,000	700	2,0	-10~+80	-	•	-	•	950
68005.W0303	25	M30 x 1,5	180	60,000	1,300	1,0	-10~+80	-	•	-	•	950

68008 - shock absorbers - self compensating

Order Number	Stroke (mm)	Thread (mm)	Max. Energy per cycle Nm (ET)	Max. Energy per hour Nm/hr (ETC)	Max Effective Mass Kg (Me)	Max. Impact Speed m/s (v)	Operating temp. (°C)	Avai. w/o cap	Avai. with cap	Flange Avai.	Stop Collar Avai.	Weight (g)
68008.W0141	15	M14 x 1,0	9,8	35,280	30	1,0	-10~+80	-	•	-	•	80
68008.W0142	15	M14 x 1,0	9,8	35,280	15	1,5	-10~+80	-	•	-	•	80
68008.W0191	20	M20 x 1,5	36	22,000	27	2	-10~+80	•	•	-	•	170
68008.W0192	25	M20 x 1,5	40	24,200	35	2	-10~+80	•	•	-	•	180
68008.W0201	30	M20 x 1,5	44	26,460	60	1,2	-10~+80	-	•	-	•	185
68008.W0202	30	M20 x 1,5	44	26,460	30	1,7	-10~+80	-	•	-	•	185
68008.W0203	30	M20 x 1,5	44	26,460	15	2,4	-10~+80	-	•	-	•	185
68008.W0204	30	M20 x 1,5	44	26,460	5	4,2	-10~+80	-	•	-	•	205
68008.W0205	30	M20 x 1,5	44	26,460	3	6,0	-10~+80	-	•	-	•	205
68008.W0211	50	M20 x 1,5	59	35,280	30	2,0	-10~+80	-	•	-	•	250
68008.W0212	50	M20 x 1,5	59	35,280	15	2,8	-10~+80	-	•	-	•	250
68008.W0213	50	M20 x 1,5	59	35,280	8	3,8	-10~+80	-	•	-	•	250
68008.W0214	50	M20 x 1,5	59	35,280	5	5,0	-10~+80	-	•	-	•	250
68008.W0215	50	M20 x 1,5	59	35,280	3	6,8	-10~+80	-	•	-	•	235

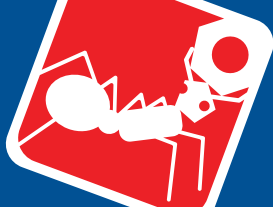

Wixroyd Shock Absorbers

capacity and selection charts



Materials Handling

68012 - shock absorbers - self compensating

Order Number	Stroke (mm)	Thread (mm)	Max. Energy per cycle Nm (ET)	Max. Energy per hour Nm/hr (ETC)	Max Effective Mass Kg (Me)	Max. Impact Speed m/s (v)	Operating temp. (°C)	Avai. w/o cap	Avai. with cap	Flange Avai.	Stop Collar Avai.	Weight (g)
68012.W0081/82	6	M14 x 1,0	3	7,000	6	2,5	-10~+80	•	•	-	•	17
68012.W0101/102	7	M14 x 1,0	6	12,400	12	3,5	-10~+80	•	•	-	•	28
68012.W0121/122	10	M20 x 1,5	12	22,500	22	4,0	-10~+80	•	•	-	•	32
68012.W0141/142	12	M20 x 1,5	20	33,000	40	5,0	-10~+80	•	•	-	•	70
68012.W0201/202	15	M20 x 1,5	59	38,000	120	5,0	-10~+80	•	•	-	•	160
68012.W0251/252	25	M20 x 1,5	80	60,000	180	5,0	-10~+80	•	•	-	•	295
68012.W0271/272	25	M20 x 1,5	147	72,000	270	5,0	-10~+80	•	•	-	•	375

68020, 68024 - shock absorbers - adjustable

Order Number	Stroke (mm)	Thread (mm)	Max. Energy per cycle Nm (ET)	Max. Energy per hour Nm/hr (ETC)	Max Effective Mass Kg (Me)	Max. Impact Speed m/s (v)	Operating temp. (°C)	Avai. w/o cap	Avai. with cap	Flange Avai.	Stop Collar Avai.	Weight (g)
68020.W0141	10	M14 x 1,5	20	25,000	80	3,0	-10~+80	•	•	-	•	90
68020.W0142	10	M14 x 1,5	20	25,000	80	3,0	-10~+80	•	•	-	•	90
68020.W0199	16	M20 x 1,5	25	28,500	200	3,5	-10~+80	•	•	-	•	222
68020.W0200	16	M20 x 1,5	25	28,500	200	3,5	-10~+80	•	•	-	•	230
68020.W0203	25	M20 x 1,5	39	30,000	200	3,5	-10~+80	•	•	-	•	230
68020.W0204	25	M20 x 1,5	39	30,000	312	3,5	-10~+80	•	•	-	•	240
68024.W0251	25	M25 x 1,5	85	54,000	400	3,5	-10~+80	•	•	-	•	335
68024.W0252	25	M25 x 1,5	85	54,000	400	3,5	-10~+80	•	•	-	•	350
68024.W0253	30	M25 x 1,5	95	60,000	480	3,5	-10~+80	•	•	-	•	340
68024.W0254	30	M25 x 1,5	95	60,000	480	3,5	-10~+80	•	•	-	•	365
68024.W0255	40	M25 x 1,5	100	80,000	700	3,5	-10~+80	-	•	-	•	455
68024.W0256	50	M25 x 1,5	98	90,000	720	4,0	-10~+80	•	•	-	•	455
68024.W0257	80	M25 x 1,5	150	120,000	800	4,0	-10~+80	•	•	-	•	585
68024.W0361	25	M36 x 1,5	150	81,000	1400	3,0	-10~+80	-	•	•	•	955
68024.W0362	50	M36 x 1,5	300	100,000	1400	3,0	-10~+80	-	•	•	•	1100
68024.W0421	25	M42 x 1,5	260	125,000	3000	3,5	-10~+80	-	•	•	-	1280
68024.W0422	50	M42 x 1,5	500	150,000	4000	4,5	-10~+80	-	•	•	-	1490
68024.W0423	75	M42 x 1,5	750	180,000	6000	4,5	-10~+80	-	•	•	-	1710



68020

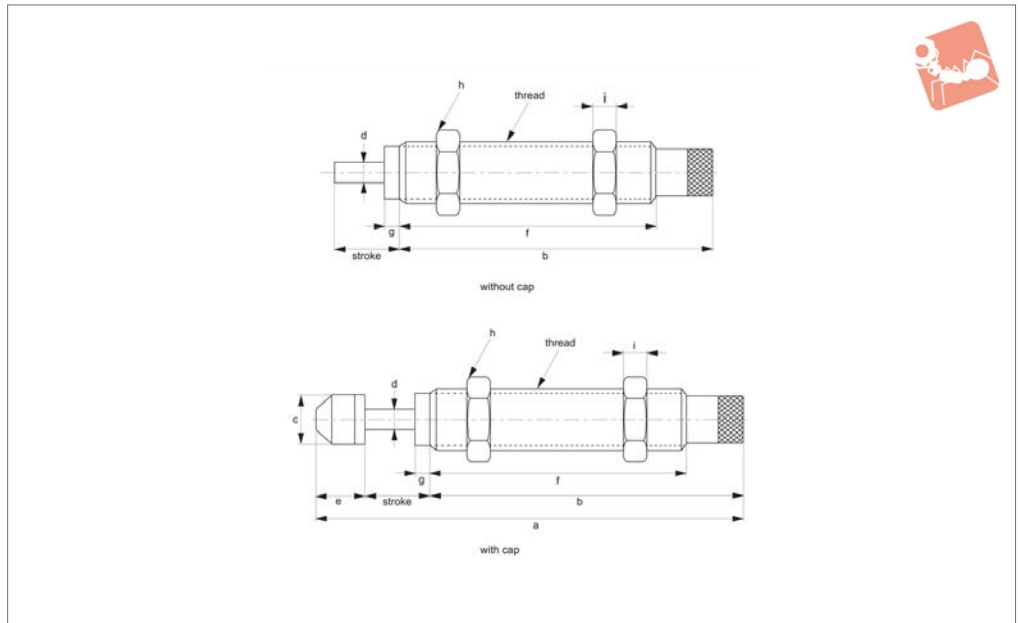

Material

Outer Tube: STKM11A, hardened and blackened.

Piston Rod: AISI 1045 hardened to HV940°, chrome plated.

Return Spring: DIN GWP.

Muffler Cap: urethane rubber.

Seal: nitrile rubber.

Technical Notes

Adjustable shock absorbers have an adjustment collar at their base to enable setting of optimum deceleration of unit to suit application.

Supplied with rubber muffler cap as standard, this is removable - see introductory technical notes for guidance.

Important Notes

For correct product selection refer to Product Selection Formulae and Calculation pages, and associated Capacity & Selection Charts.

Order No.	With / without cap	Stroke mm	Per hour (ETc)		Nm per cycle (Et)		Effective mass (Me)		Speed (v) m/s max.	Operating temperature °C	Weight g
			Nm max.	Nm max.	Nm max.	Nm max.	kg max.	kg max.			
68020.W0139	Without	10	22000	12	35	3.0	-10 to +80	66			
68020.W0140	With	10	22000	12	35	3.0	-10 to +80	66			
68020.W0141	Without	10	25000	20	80	3.0	-10 to +80	90			
68020.W0142	With	10	25000	20	80	3.0	-10 to +80	90			
68020.W0143	Without	15	26000	24	100	3.0	-10 to +80	120			
68020.W0144	With	15	26000	24	100	3.0	-10 to +80	120			
68020.W0145	Without	25	27500	28	140	3.0	-10 to +80	194			
68020.W0146	With	25	27500	28	140	3.0	-10 to +80	194			
68020.W0147	Without	12	27500	22	130	3.0	-10 to +80	200			
68020.W0148	With	12	27500	22	130	3.0	-10 to +80	200			
68020.W0199	Without	16	28500	28	200	3.5	-10 to +80	222			
68020.W0200	With	16	28500	28	200	3.5	-10 to +80	230			
68020.W0201	Without	16	27500	28	200	3.0	-10 to +80	230			
68020.W0202	With	16	27500	28	200	3.0	-10 to +80	230			
68020.W0203	Without	25	30000	39	312	3.5	-10 to +80	232			
68020.W0204	With	25	30000	39	312	3.5	-10 to +80	240			
68020.W0205	Without	20	29000	34	298	3.5	-10 to +80	235			
68020.W0206	With	20	29000	34	298	3.5	-10 to +80	235			
68020.W0207	Without	50	52000	69	420	3.5	-10 to +80	330			
68020.W0208	With	50	52000	69	420	3.5	-10 to +80	330			

Order No.	Thread	a	b	c	d	e	f	h	i
68020.W0139	M14x1,5	90.3	71.7	10.3	4	8.6	57.3	14	4
68020.W0140	M14x1,5	90.3	71.7	10.3	4	8.6	57.3	14	4
68020.W0141	M14x1,5	109.5	88.5	12	4	11.2	72.5	19	5
68020.W0142	M14x1,5	109.5	88.5	12	4	11.0	72.5	19	5
68020.W0143	M14x1,5	128.2	102	12	4	11.2	86.0	19	5
68020.W0144	M14x1,5	128.2	102	12	4	11.2	86.0	19	5



Shock Absorber, Adjustable

M14 - M20

Shock Absorbers

Order No.	Thread	a	b	c	d	e	f	h	i
68020.W0145	M14x1,5	153.2	117	12	4	11.2	101.0	19	5
68020.W0146	M14x1,5	153.2	117	12	4	11.2	101.0	19	5
68020.W0147	M16x1,5	99.0	76.5	14	4	11.2	54.9	19	6
68020.W0148	M16x1,5	99.0	76.5	14	4	11.2	54.9	19	6
68020.W0199	M20x1,5	-	117.0	-	6	-	101.0	26	7
68020.W0200	M20x1,5	158.0	117.0	18	6	15.8	101.0	26	7
68020.W0201	M20x2,0	148.3	117.0	17.8	6	15.3	101.0	26	7
68020.W0202	M20x2,0	148.3	117.0	17.8	6	15.3	101.0	26	7
68020.W0203	M20x1,5	157.3	117.0	17.8	6	15.3	101.0	26	7
68020.W0204	M20x1,5	157.3	117.0	17.8	6	15.3	101.0	26	7
68020.W0205	M20x1,5	152.3	117.0	17.8	6	15.3	101.0	26	7
68020.W0206	M20x1,5	152.3	117.0	17.8	6	15.3	101.0	26	7
68020.W0207	M20x1,5	239.3	174	17.8	6	15.3	158.0	26	7
68020.W0208	M20x1,5	239.3	174	17.8	6	15.3	158.0	26	7

SHOCK ABSORBERS





68024

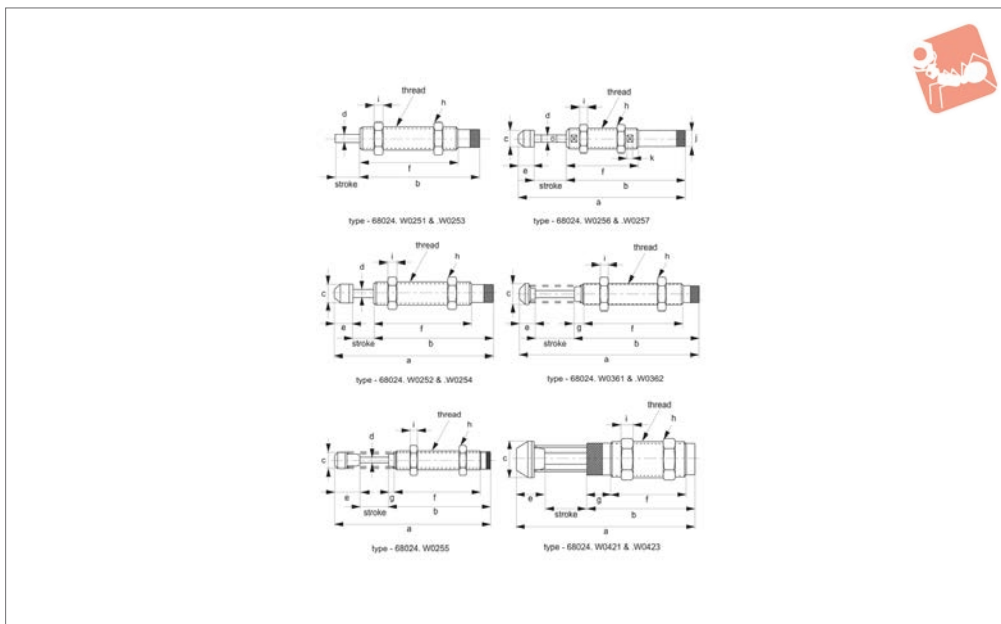

Material

Outer Tube: STKM11A, hardened and blackened.

Piston Rod: AISI 1045 hardened to HV940°, chrome plated.

Return Spring: DIN GWP.

Muffler Cap: urethane rubber.

Seal: nitrile rubber.

Technical Notes

Adjustable shock absorbers have an adjust-

ment collar at their base to enable setting of optimum deceleration of unit to suit application.

After initial installation, cycle unit a number of times to settle, then turn adjustment collar to desired position for application.

Supplied with rubber muffler cap as standard, this is removable - see introductory technical notes for guidance.

Important Notes

For correct product selection refer to Product Selection Formulae and Calculation pages, and associated Capacity & Selection Charts.

Order No.	With / without cap	Stroke mm	Per hour (ETc) Nm max.	Nm per cycle (Et) Nm max.	Effective mass (Me) kg max.	Impact speed (v) m/s max.	Operating temperature °C	Weight g
68024.W0251	Without	25	54000	85	400	3.5	-10 to +80	335
68024.W0252	With	25	54000	85	400	3.5	-10 to +80	350
68024.W0253	Without	30	60000	95	480	3.5	-10 to +80	340
68024.W0254	With	30	60000	95	480	3.5	-10 to +80	365
68024.W0255	With	40	80000	100	700	3.5	-10 to +80	455
68024.W0256	With	50	90000	120	720	4.0	-10 to +80	455
68024.W0257	With	80	120000	150	800	4.0	-10 to +80	585
68024.W0361	With	25	81000	150	1400	3.0	-10 to +80	955
68024.W0362	With	50	81000	300	1400	3.0	-10 to +80	1100
68024.W0260	Without	25	75700	195	1400	3.3	-10 to +80	482
68024.W0261	Without	25	75700	195	1400	3.3	-10 to +80	482
68024.W0262	With	52	98962	385	2400	3.3	-10 to +80	708
68024.W0263	Without	52	98962	385	2400	3.3	-10 to +80	708
68024.W0421	With	25	125000	260	3000	3.5	-10 to +80	1280
68024.W0422	With	50	150000	500	4000	4.5	-10 to +80	1490
68024.W0423	With	75	180000	750	6000	4.5	-10 to +80	1710

Order No.	Thread	a	b	c	d	e	f	h	g	i	j	k
68024.W0251	M25x1,5	-	118.5	-	8	-	101.0	32	-	9	-	-
68024.W0252	M25x1,5	163.0	118.5	22.0	8	19.0	101.0	32	-	9	-	-
68024.W0253	M25x1,5	-	118.5	-	8	-	101.0	32	-	9	-	-
68024.W0254	M25x1,5	167.5	118.5	22.0	8	19.0	101.0	32	-	9	-	-
68024.W0255	M25x1,5	221.5	144.5	22.0	8	37.0	117.0	32	10.0	9	-	-
68024.W0256	M25x1,5	247.0	178.0	22.0	8	19.0	100.0	32	-	9	23	11



Shock Absorber, Adjustable

M25 - M42

Shock Absorbers

Order No.	Thread	a	b	c	d	e	f	h	g	i	j	k
68024.W0257	M25x1,5	343.5	244.5	22.0	8	19.0	100.0	32	-	9	23	11
68024.W0361	M36x1,5	183.8	123.0	35.5	10	25.8	103.0	46	10.0	15	-	-
68024.W0362	M36x1,5	246.8	154.0	35.5	10	25.8	134.0	46	17.0	15	-	-
68024.W0260	M33x1,5	150.3	110.5	28.5	10	13.8	77.9	45	19.1	11	29.7	16
68024.W0261	M33x1,5	150.3	110.5	28.5	10	13.8	77.9	45	19.1	11	29.7	16
68024.W0262	M33x1,5	217.3	151.5	28.5	10	13.8	118.7	45	19.1	11	29.7	16
68024.W0263	M33x1,5	217.3	151.5	28.5	10	13.8	118.7	45	19.1	11	29.7	16
68024.W0421	M42x1,5	186.4	127.5	44.5	12	33.9	88.0	50	28.5	15	-	-
68024.W0422	M42x1,5	240.9	157.0	44.5	12	33.9	117.5	50	28.5	15	-	-
68024.W0423	M42x1,5	301.4	187.5	44.5	12	33.9	148.0	50	28.5	15	-	-





SHOCK ABSORBERS

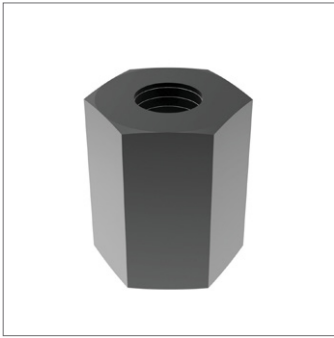

68030

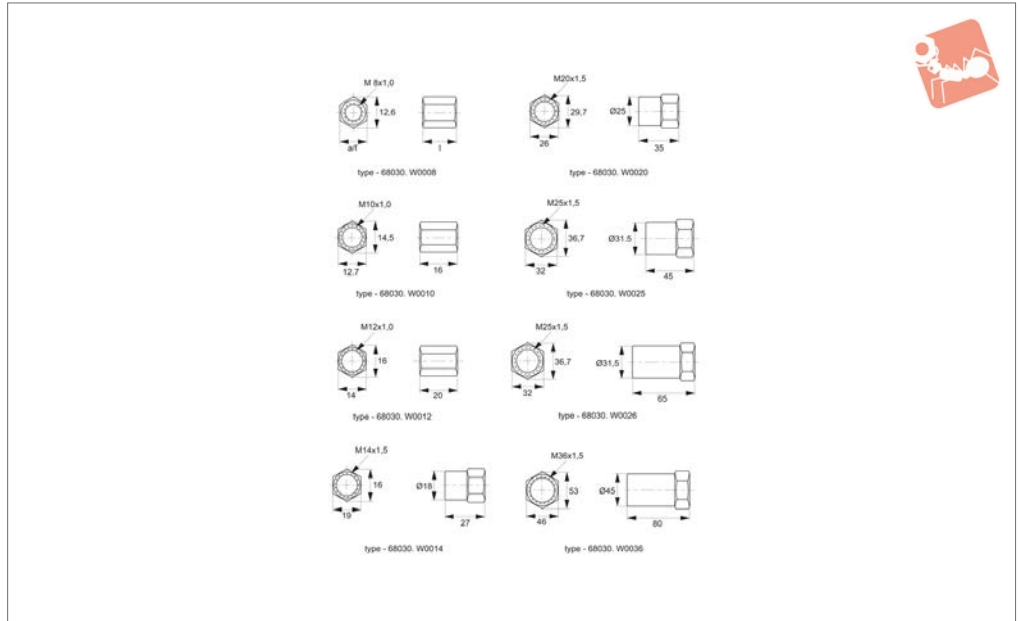

Material

Steel, hardened and blackened.

Technical Notes

For use with Wixroyd range of shock absorbers,

stop collars can be used to adjust both the stroke and fixing position of the shock absorber.

Stop collar plus half nut supplied.

Order No.	Thread	l	To suit shock absorber size	A/F	Dia. Ø
68030.W0008	M 8x1,0	14	68001.W0081, .W0082, .W0083 68012.W0081, .W0082	11.0	-
68030.W0010	M10x1,0	16	68001.W0101, .W0102, .W0103, .W0104, .W0105, .W0106 68012.W0101, .W0102	12.7	-
68030.W0012	M12x1,0	20	68001.W0121, .W0122, .W0123 68012.W0121, .W0122	14.0	-
68030.W0014	M14x1,5	27	68002.W0141, .W0142, .W0143, .W0144, .W0145, .W0146 68008.W0141, .W0142 68012.W0141, .W0142 68020.W0141, .W0142	19.0	18.0
68030.W0020	M20x1,5	35	68002.W0201, .W0202, .W0203, .W0204, .W0205, .W0206, .W0207, .W0208, .W0209 68004.W0201, .W0202, .W0203, .W0204, .W0205, .W0206 68008.W0201, .W0202, .W0203, .W0204, .W0205, .W0206	26.0	25.0
68030.W0025	M25x1,5	45	68003.W0251, .W0252, .W0253, .W0257, .W0258, .W0259, .W0260, .W0261, .W0262, .W0263 68012.W0251, .W0252 68024.W0252, .W0254, .W0255, .W0257	32.0	31.5
68030.W0026	M25x1,5	65	68003.W0254, .W0255, .W0256 68024.W0255	32.0	31.5
68030.W0036	M36x1,5	80	68003.W0361, .W0362, .W0363 68024.W0361, .W0362	46.0	45.0



Stop Collars for Shock Absorbers

M8 to M36

Shock Absorbers

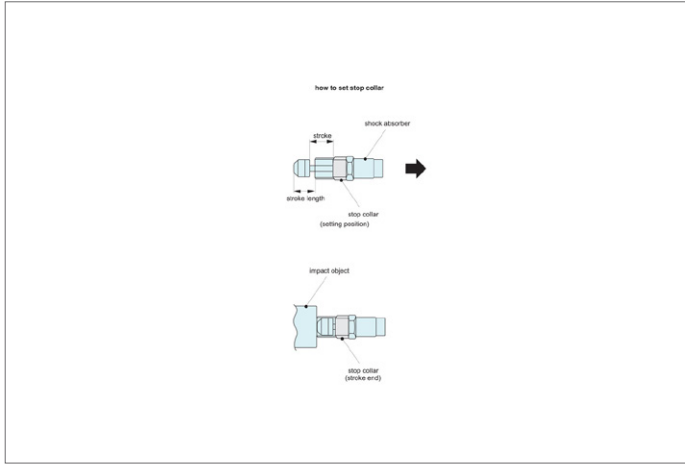



SHOCK ABSORBERS

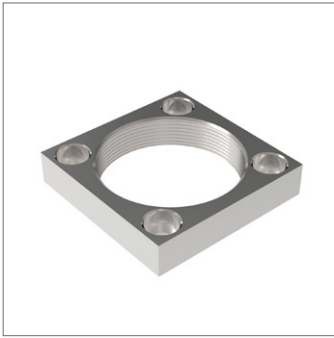

68032

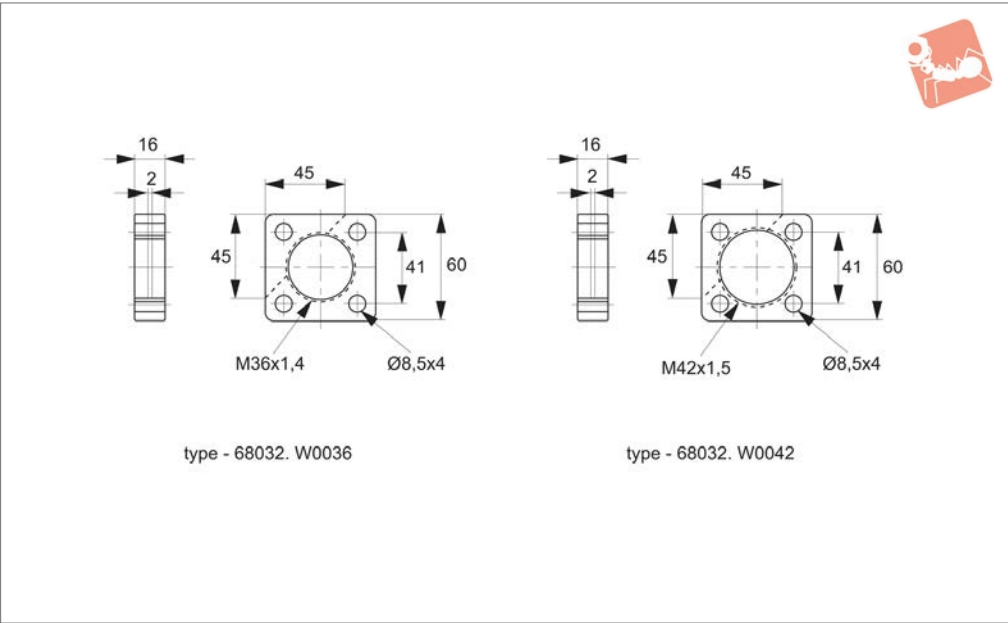

Material

Steel, hardened and blackened.

Technical Notes

Provide easy mounting of Wixroyd Shock Absorbers in our application.

Order No.	Thread	To suit shock absorber size
68032.W0036	M36 x 1,5	68003.W0361, .W0362, .W0363
68032.W0042	M42 x 1,5	68024.W0361, .W0632 68024.W0421, .W0422, .W0423



Thrust Screws - Ball Ended

headless - round ball - metal

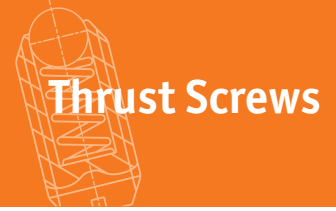

Thrust Screws

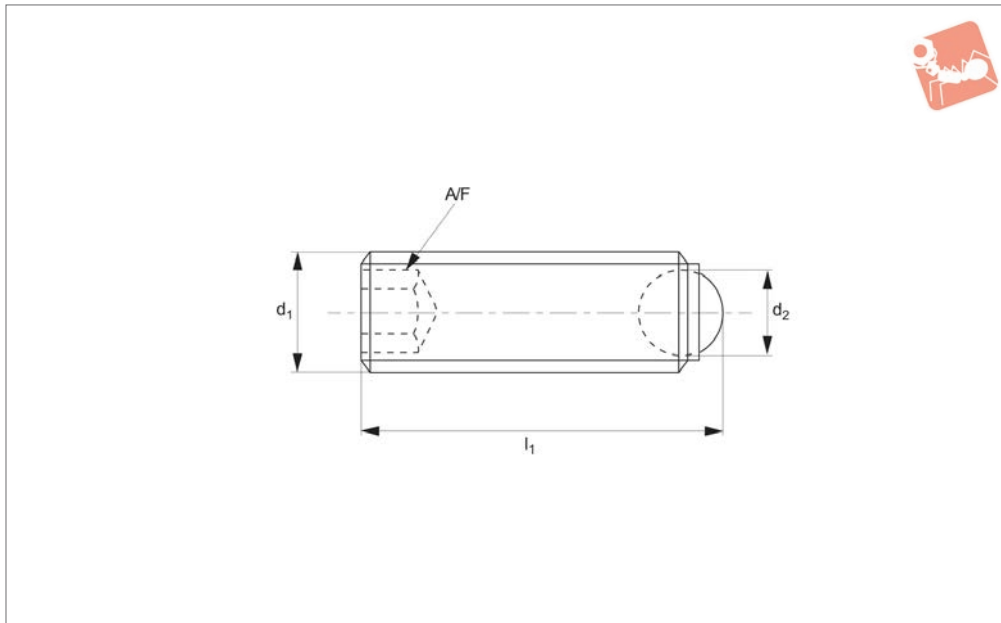

34041

THRUST SCREWS

Material

Steel type-

Body: steel, heat-treated, 1200 ±100 N/mm².

Ball: ball bearing steel, hardened.

Stainless steel type-

Body: stainless steel (AISI 303, 1.4305).

Ball: stainless steel, hardened.

Technical Notes

For clamping, tightening or supporting of surfaces that are not exactly parallel.

Max. temperature 250°C.

Tips

Ball not secured against rotation. For other types see following pages.

Important Notes

*Max. static load relates to steel version only.

Order No.	Material	Ball type	d ₁	d ₂	l ₁	A/F	Static load kN max.	Weight g
34041.W0032	Steel	Round	M 3	1.5	5.0	1.5	2.5	0.2
34041.W0033	Steel	Round	M 3	1.5	7.5	1.5	2.5	0.2
34041.W0034	Steel	Round	M 3	1.5	10.0	1.5	2.5	0.3
34041.W0042	Steel	Round	M 4	2.5	6.0	2.0	3.5	0.5
34041.W0043	Steel	Round	M 4	2.5	8.0	2.0	3.5	0.6
34041.W0044	Steel	Round	M 4	2.5	10.0	2.0	3.5	0.8
34041.W0045	Steel	Round	M 4	2.5	12.0	2.0	3.5	0.7
34041.W0046	Steel	Round	M 4	2.5	16.0	2.0	3.5	1.2
34041.W0052	Steel	Round	M 5	3.0	8.0	2.5	4.5	0.8
34041.W0053	Steel	Round	M 5	3.0	10.0	2.5	4.5	1.1
34041.W0054	Steel	Round	M 5	3.0	12.0	2.5	4.5	1.3
34041.W0055	Steel	Round	M 5	3.0	16.0	2.5	4.5	1.5
34041.W0056	Steel	Round	M 5	3.0	20.0	2.5	4.5	2.2
34041.W0058	Steel	Round	M 5	3.0	25.0	2.5	4.5	2.8
34041.W0062	Steel	Round	M 6	4.0	10.8	3.0	9.0	1.5
34041.W0063	Steel	Round	M 6	4.0	12.8	3.8	9.0	1.9
34041.W0064	Steel	Round	M 6	4.0	16.8	3.0	9.0	2.5
34041.W0065	Steel	Round	M 6	4.0	20.8	3.0	9.0	3.3
34041.W0066	Steel	Round	M 6	4.0	25.8	3.0	9.0	4.0
34041.W0081	Steel	Round	M 8	5.5	11.2	4.0	15.0	2.6
34041.W0082	Steel	Round	M 8	5.5	13.2	4.0	15.0	3.0
34041.W0083	Steel	Round	M 8	5.5	17.2	4.0	15.0	4.2
34041.W0084	Steel	Round	M 8	5.5	21.2	4.0	15.0	5.4
34041.W0085	Steel	Round	M 8	5.5	26.2	4.0	15.0	6.9
34041.W0086	Steel	Round	M 8	5.5	31.2	4.0	15.0	8.4
34041.W0101	Steel	Round	M10	7.0	13.7	5.0	20.0	4.8
34041.W0102	Steel	Round	M10	7.0	17.7	5.0	20.0	6.2
34041.W0103	Steel	Round	M10	7.0	21.7	5.0	20.0	8.1
34041.W0104	Steel	Round	M10	7.0	26.7	5.0	20.0	11.0
34041.W0105	Steel	Round	M10	7.0	31.7	5.0	20.0	13.0



Order No.	Material	Ball type	d ₁	d ₂	l ₁	A/F	Static load kN max.	Weight g
34041.W0106	Steel	Round	M10	7.0	36.7	5.0	20.0	15.0
34041.W0108	Steel	Round	M10	7.0	41.7	5.0	20.0	15.0
34041.W0121	Steel	Round	M12	8.5	18.0	6.0	30.0	9.3
34041.W0122	Steel	Round	M12	8.5	22.0	6.0	30.0	11.0
34041.W0123	Steel	Round	M12	8.5	27.0	6.0	30.0	15.0
34041.W0124	Steel	Round	M12	8.5	32.0	6.0	30.0	18.0
34041.W0126	Steel	Round	M12	8.5	42.0	6.0	30.0	25.0
34041.W0128	Steel	Round	M12	8.5	52.0	6.0	30.0	32.5
34041.W0161	Steel	Round	M16	12.0	23.3	8.0	30.0	22.0
34041.W0162	Steel	Round	M16	12.0	28.3	8.0	60.0	27.0
34041.W0164	Steel	Round	M16	12.0	38.3	8.0	60.0	40.0
34041.W0166	Steel	Round	M16	12.0	53.3	8.0	60.0	62.0
34041.W0202	Steel	Round	M20	15.0	34.2	10.0	90.0	52.0
34041.W0204	Steel	Round	M20	15.0	42.2	10.0	90.0	72.0
34041.W0205	Steel	Round	M20	15.0	54.2	10.0	90.0	93.0
34041.W0206	Steel	Round	M20	15.0	64.2	10.0	90.0	115.0
34041.W0242	Steel	Round	M24	18.0	39.7	12.0	120.0	87.0
34041.W0244	Steel	Round	M24	18.0	54.7	12.0	120.0	129.0
34041.W0246	Steel	Round	M24	18.0	84.7	12.0	120.0	222.0
34041.W0747	Stainless	Round	M 3	1.5	5.0	1.5	-	0.2
34041.W0748	Stainless	Round	M 3	1.5	7.5	1.5	-	0.2
34041.W0749	Stainless	Round	M 3	1.5	10.0	1.5	-	0.3
34041.W0750	Stainless	Round	M 4	2.5	6.0	2.0	-	0.5
34041.W0752	Stainless	Round	M 4	2.5	8.0	2.0	-	0.6
34041.W0754	Stainless	Round	M 4	2.5	10.0	2.0	-	0.8
34041.W0756	Stainless	Round	M 4	2.5	12.0	2.0	-	0.7
34041.W0758	Stainless	Round	M 4	2.5	16.0	2.0	-	1.2
34041.W0760	Stainless	Round	M 5	3.0	8.0	2.5	-	0.8
34041.W0761	Stainless	Round	M 5	3.0	10.0	2.5	-	1.1
34041.W0762	Stainless	Round	M 5	3.0	12.0	2.5	-	1.3
34041.W0763	Stainless	Round	M 5	3.0	16.0	2.5	-	1.5
34041.W0764	Stainless	Round	M 5	3.0	20.0	2.5	-	2.2
34041.W0765	Stainless	Round	M 5	3.0	25.0	2.5	-	2.8
34041.W0770	Stainless	Round	M 6	4.0	10.8	3.0	-	1.5
34041.W0772	Stainless	Round	M 6	4.0	12.8	3.0	-	1.9
34041.W0774	Stainless	Round	M 6	4.0	16.8	3.0	-	2.5
34041.W0775	Stainless	Round	M 6	4.0	20.8	3.0	-	3.3
34041.W0776	Stainless	Round	M 6	4.0	25.8	3.0	-	4.0
34041.W0780	Stainless	Round	M 8	5.5	11.2	4.0	-	2.6
34041.W0782	Stainless	Round	M 8	5.5	13.2	4.0	-	3.0
34041.W0783	Stainless	Round	M 8	5.5	17.2	4.0	-	4.2
34041.W0784	Stainless	Round	M 8	5.5	21.2	4.0	-	5.4
34041.W0785	Stainless	Round	M 8	5.5	26.2	4.0	-	6.9
34041.W0786	Stainless	Round	M 8	5.5	31.2	4.0	-	8.4
34041.W0790	Stainless	Round	M10	7.0	13.7	5.0	-	4.8
34041.W0792	Stainless	Round	M10	7.0	17.7	5.0	-	6.2
34041.W0793	Stainless	Round	M10	7.0	21.7	5.0	-	8.1
34041.W0794	Stainless	Round	M10	7.0	26.7	5.0	-	11.0
34041.W0795	Stainless	Round	M10	7.0	31.7	5.0	-	13.0
34041.W0796	Stainless	Round	M10	7.0	36.7	5.0	-	15.0
34041.W0798	Stainless	Round	M10	7.0	41.7	5.0	-	15.0
34041.W0800	Stainless	Round	M12	8.5	18.0	6.0	-	9.3
34041.W0802	Stainless	Round	M12	8.5	22.0	6.0	-	11.0
34041.W0803	Stainless	Round	M12	8.5	27.0	6.0	-	15.0
34041.W0804	Stainless	Round	M12	8.5	32.0	6.0	-	18.0
34041.W0806	Stainless	Round	M12	8.5	42.0	6.0	-	25.0
34041.W0808	Stainless	Round	M12	8.5	52.0	6.0	-	32.5
34041.W0810	Stainless	Round	M16	12.0	23.3	8.0	-	22.0
34041.W0812	Stainless	Round	M16	12.0	28.3	8.0	-	27.0
34041.W0814	Stainless	Round	M16	12.0	38.3	8.0	-	40.0
34041.W0816	Stainless	Round	M16	12.0	53.3	8.0	-	62.0



Thrust Screws - Ball Ended

headless - flat-faced ball - metal

Thrust Screws

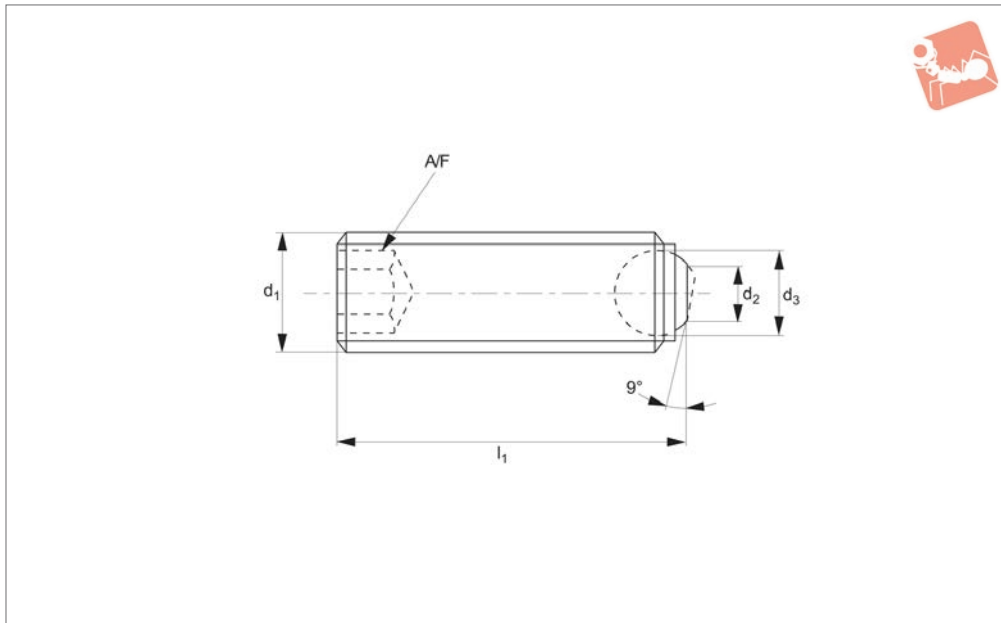

34043

THRUST SCREWS

Material

Steel type-

Body: steel, heat-treated, 1200 ±100 N/mm².

Ball: ball bearing steel, hardened.

Stainless steel type-

Body: stainless steel (AISI 303, 1.4305).

Ball: stainless steel, hardened.

Technical Notes

For clamping, tightening or supporting surfaces that are not exactly parallel.

Max. temperature 250°C.

Tips

Ball not secured against rotation. It is

possible for the flat-faced ball to flip and expose the spherical face of the ball. For other types see following pages.

Important Notes

*Max. static load relates to steel version only.

Order No.	Material	Ball type	d ₁	d ₂	d ₃	l ₁	A/F	Static load kN max.	Weight g
34043.W0542	Steel	Flat, Plain	M 4	1.8	2.5	5.6	2	3.5	0.3
34043.W0543	Steel	Flat, Plain	M 4	1.8	2.5	7.6	2	3.5	0.6
34043.W0544	Steel	Flat, Plain	M 4	1.8	2.5	9.6	2	3.5	0.5
34043.W0545	Steel	Flat, Plain	M 4	1.8	2.5	11.6	2	3.5	0.9
34043.W0546	Steel	Flat, Plain	M 4	1.8	2.5	15.6	2	3.5	1.0
34043.W0552	Steel	Flat, Plain	M 5	2.2	3.0	7.5	3	4.5	0.6
34043.W0553	Steel	Flat, Plain	M 5	2.2	3.0	9.5	3	4.5	0.8
34043.W0554	Steel	Flat, Plain	M 5	2.2	3.0	11.5	3	4.5	1.1
34043.W0555	Steel	Flat, Plain	M 5	2.2	3.0	15.5	3	4.5	1.7
34043.W0556	Steel	Flat, Plain	M 5	2.2	3.0	19.5	3	4.5	2.2
34043.W0558	Steel	Flat, Plain	M 5	2.2	3.0	24.5	3	4.5	2.6
34043.W0562	Steel	Flat, Plain	M 6	3.2	4.0	10.0	3	9.0	1.5
34043.W0563	Steel	Flat, Plain	M 6	3.2	4.0	12.0	3	9.0	1.6
34043.W0564	Steel	Flat, Plain	M 6	3.2	4.0	16.0	3	9.0	2.5
34043.W0565	Steel	Flat, Plain	M 6	3.2	4.0	20.0	3	9.0	3.2
34043.W0566	Steel	Flat, Plain	M 6	3.2	4.0	25.0	3	9.0	3.8
34043.W0581	Steel	Flat, Plain	M 8	4.5	5.5	10.0	4	15.0	2.6
34043.W0582	Steel	Flat, Plain	M 8	4.5	5.5	12.0	4	15.0	2.9
34043.W0583	Steel	Flat, Plain	M 8	4.5	5.5	16.0	4	15.0	4.0
34043.W0584	Steel	Flat, Plain	M 8	4.5	5.5	20.0	4	15.0	5.3
34043.W0585	Steel	Flat, Plain	M 8	4.5	5.5	25.0	4	15.0	6.8
34043.W0586	Steel	Flat, Plain	M 8	4.5	5.5	30.0	4	15.0	8.4
34043.W0601	Steel	Flat, Plain	M10	6.0	7.0	12.0	5	20.0	4.7
34043.W0602	Steel	Flat, Plain	M10	6.0	7.0	16.0	5	20.0	6.1
34043.W0603	Steel	Flat, Plain	M10	6.0	7.0	20.0	5	20.0	7.9
34043.W0604	Steel	Flat, Plain	M10	6.0	7.0	25.0	5	20.0	10.0
34043.W0605	Steel	Flat, Plain	M10	6.0	7.0	30.0	5	20.0	13.0
34043.W0606	Steel	Flat, Plain	M10	6.0	7.0	35.0	5	20.0	15.0



Order No.	Material	Ball type	d ₁	d ₂	d ₃	l ₁	A/F	Static load kN max.	Weight g
34043.W0608	Steel	Flat, Plain	M10	6.0	7.0	40.0	5	20.0	18.0
34043.W0621	Steel	Flat, Plain	M12	7.2	8.5	16.0	6	30.0	9.1
34043.W0622	Steel	Flat, Plain	M12	7.2	8.5	20.0	6	30.0	11.0
34043.W0623	Steel	Flat, Plain	M12	7.2	8.5	25.0	6	30.0	14.0
34043.W0624	Steel	Flat, Plain	M12	7.2	8.5	30.0	6	30.0	18.0
34043.W0626	Steel	Flat, Plain	M12	7.2	8.5	40.0	6	30.0	25.0
34043.W0628	Steel	Flat, Plain	M12	7.2	8.5	50.0	6	30.0	32.0
34043.W0661	Steel	Flat, Plain	M16	10.7	12.0	20.0	8	60.0	21.0
34043.W0662	Steel	Flat, Plain	M16	10.7	12.0	25.0	8	60.0	26.0
34043.W0664	Steel	Flat, Plain	M16	10.7	12.0	35.0	8	60.0	39.0
34043.W0666	Steel	Flat, Plain	M16	10.7	12.0	50.0	8	60.0	60.0
34043.W0702	Steel	Flat, Plain	M20	13.5	15.0	30.0	10	90.0	49.0
34043.W0704	Steel	Flat, Plain	M20	13.5	15.0	40.0	10	90.0	70.0
34043.W0705	Steel	Flat, Plain	M20	13.5	15.0	50.0	10	90.0	90.0
34043.W0706	Steel	Flat, Plain	M20	13.5	15.0	60.0	10	90.0	111.0
34043.W0742	Steel	Flat, Plain	M24	15.8	18.0	35.0	12	120.0	86.0
34043.W0744	Steel	Flat, Plain	M24	15.8	18.0	50.0	12	120.0	128.0
34043.W0746	Steel	Flat, Plain	M24	15.8	18.0	80.0	12	120.0	219.0
34043.W0827	Stainless	Flat, Plain	M 4	1.8	2.5	5.6	2	-	0.5
34043.W0828	Stainless	Flat, Plain	M 4	1.8	2.5	7.6	2	-	0.6
34043.W0829	Stainless	Flat, Plain	M 4	1.8	2.5	9.6	2	-	0.5
34043.W0830	Stainless	Flat, Plain	M 4	1.8	2.5	11.6	2	-	0.9
34043.W0832	Stainless	Flat, Plain	M 4	1.8	2.5	15.6	2	-	1.0
34043.W0833	Stainless	Flat, Plain	M 5	2.2	3.0	7.5	3	-	0.6
34043.W0834	Stainless	Flat, Plain	M 5	2.2	3.0	9.5	3	-	0.8
34043.W0835	Stainless	Flat, Plain	M 5	2.2	3.0	11.5	3	-	1.1
34043.W0836	Stainless	Flat, Plain	M 5	2.2	3.0	15.5	3	-	1.7
34043.W0837	Stainless	Flat, Plain	M 5	2.2	3.0	19.5	3	-	2.2
34043.W0838	Stainless	Flat, Plain	M 5	2.2	3.0	24.5	3	-	2.6
34043.W0840	Stainless	Flat, Plain	M 6	3.2	4.0	10.0	3	-	1.5
34043.W0842	Stainless	Flat, Plain	M 6	3.2	4.0	12.0	3	-	1.6
34043.W0844	Stainless	Flat, Plain	M 6	3.2	4.0	16.0	3	-	2.5
34043.W0845	Stainless	Flat, Plain	M 6	3.2	4.0	20.0	3	-	3.2
34043.W0846	Stainless	Flat, Plain	M 6	3.2	4.0	25.0	3	-	3.8
34043.W0850	Stainless	Flat, Plain	M 8	4.5	5.5	10.0	4	-	2.6
34043.W0852	Stainless	Flat, Plain	M 8	4.5	5.5	12.0	4	-	2.9
34043.W0853	Stainless	Flat, Plain	M 8	4.5	5.5	16.0	4	-	4.0
34043.W0854	Stainless	Flat, Plain	M 8	4.5	5.5	20.0	4	-	5.3
34043.W0855	Stainless	Flat, Plain	M 8	4.5	5.5	25.0	4	-	6.8
34043.W0856	Stainless	Flat, Plain	M 8	4.5	5.5	30.0	4	-	8.4
34043.W0860	Stainless	Flat, Plain	M10	6.0	7.0	12.0	5	-	4.7
34043.W0862	Stainless	Flat, Plain	M10	6.0	7.0	16.0	5	-	6.1
34043.W0863	Stainless	Flat, Plain	M10	6.0	7.0	20.0	5	-	7.9
34043.W0864	Stainless	Flat, Plain	M10	6.0	7.0	25.0	5	-	10.0
34043.W0865	Stainless	Flat, Plain	M10	6.0	7.0	30.0	5	-	13.0
34043.W0866	Stainless	Flat, Plain	M10	6.0	7.0	35.0	5	-	15.0
34043.W0868	Stainless	Flat, Plain	M10	6.0	7.0	40.0	5	-	18.0
34043.W0870	Stainless	Flat, Plain	M12	7.2	8.5	16.0	6	-	9.1
34043.W0872	Stainless	Flat, Plain	M12	7.2	8.5	20.0	6	-	11.0
34043.W0873	Stainless	Flat, Plain	M12	7.2	8.5	25.0	6	-	14.0
34043.W0874	Stainless	Flat, Plain	M12	7.2	8.5	30.0	6	-	18.0
34043.W0876	Stainless	Flat, Plain	M12	7.2	8.5	40.0	6	-	25.0
34043.W0878	Stainless	Flat, Plain	M12	7.2	8.5	50.0	6	-	32.0
34043.W0880	Stainless	Flat, Plain	M16	10.7	12.0	20.0	8	-	21.0
34043.W0882	Stainless	Flat, Plain	M16	10.7	12.0	25.0	8	-	26.0
34043.W0884	Stainless	Flat, Plain	M16	10.7	12.0	35.0	8	-	39.0
34043.W0886	Stainless	Flat, Plain	M16	10.7	12.0	50.0	8	-	60.0



Thrust Screws - Headless -Torx drive

ball ended - round - metal



Thrust Screws

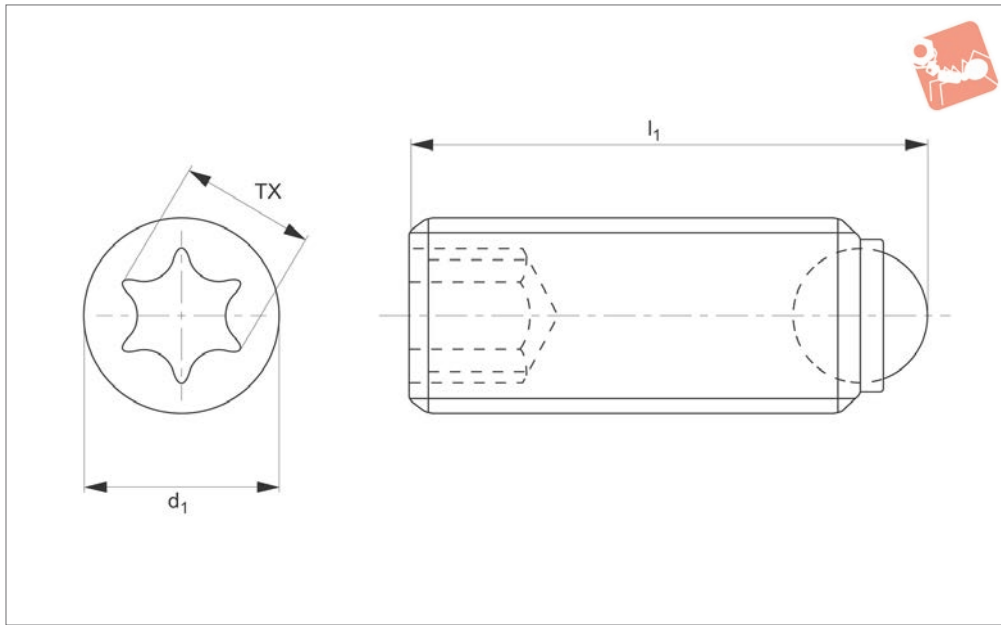

34047

THRUST SCREWS

Material

Steel type-

Body: heat treated steel, 1200 +/-100 N/mm².

Ball: ball bearing steel hardened.

Stainless steel type-

Body: stainless steel 1.4305 (AISI 303).

Ball: stainless steel, hardened.

Technical Notes

For clamping, tightening or supporting of surfaces that are not exactly parallel.

*** stated load capacity relate to steel version only.**

Torx drive for improved installation.

Tips

Ball not secured against rotation. For other types see following pages.

Order No.	Ball type	Material type	d ₁	l ₁	Ball dia.	TX drive	Static load kN max.	Weight g
34047.W1042	Round	Steel 12,9	M4	6.0	2.5	8	3.5	0.5
34047.W2042	Round	Stainless	M4	6.0	2.5	8	3.5	0.5
34047.W1044	Round	Steel 12,9	M4	10.0	2.5	8	3.5	0.6
34047.W2044	Round	Stainless	M4	10.0	2.5	8	3.5	0.6
34047.W1052	Round	Steel 12,9	M5	8.0	3.0	10	4.5	0.8
34047.W2052	Round	Stainless	M5	8.0	3.0	10	4.5	0.8
34047.W1054	Round	Steel 12,9	M5	12.0	3.0	10	4.5	1.3
34047.W2054	Round	Stainless	M5	12.0	3.0	10	4.5	1.3
34047.W1062	Round	Steel 12,9	M6	10.8	4.0	15	9.0	1.5
34047.W2062	Round	Stainless	M6	10.8	4.0	15	9.0	1.5
34047.W1064	Round	Steel 12,9	M6	16.8	4.0	15	9.0	1.9
34047.W2064	Round	Stainless	M6	16.8	4.0	15	9.0	1.9



34048

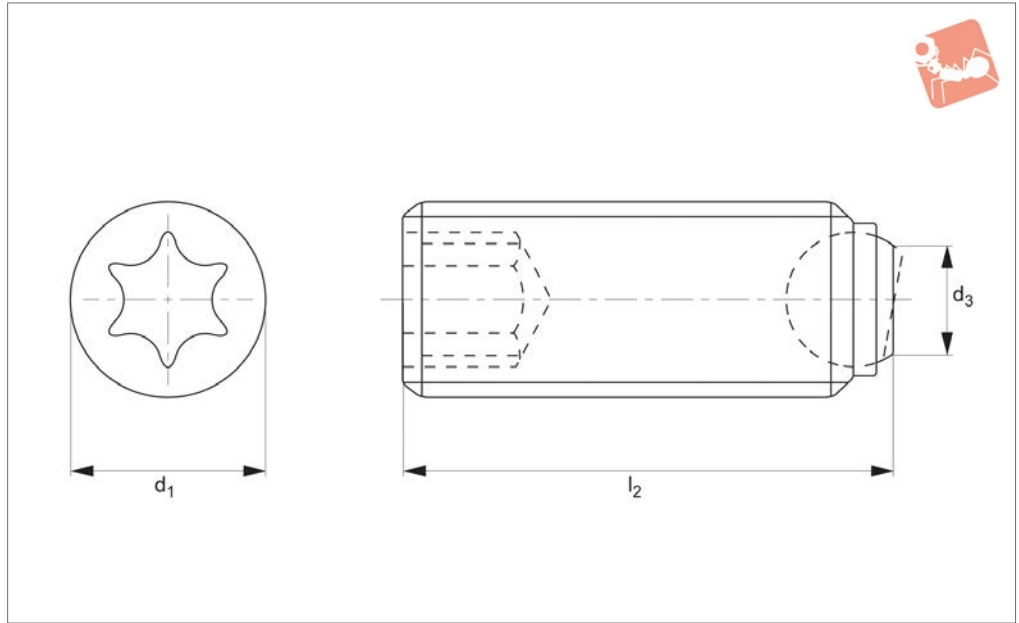

THRUST SCREWS

Material

Steel type-

Body: heat treated steel, 1200 +/-100 N/mm².

Ball: ball bearing steel hardened.

Stainless steel type-

Body: stainless steel 1.4305 (AISI 303).

Ball: stainless steel, hardened.

Technical Notes

For clamping, tightening or supporting of surfaces that are not exactly parallel.

*** stated load capacity relate to steel version only.**

Torx drive for improved installation.

Tips

Ball not secured against rotation. For other types see following pages.

Order No.	Material	Ball type	d ₁	l ₁	Ball dia.	A/F	Static load kN max.	Weight g
34048.W1542	Steel	Flat, plain	M4	0.5	1.8	8	3.5	5.6
34048.W1544	Steel	Flat, plain	M4	0.5	1.8	8	3.5	9.6
34048.W1552	Steel	Flat, plain	M5	0.6	2.2	10	4.5	7.5
34048.W1554	Steel	Flat, plain	M5	1.1	2.2	10	4.5	11.5
34048.W1562	Steel	Flat, plain	M6	1.5	3.2	15	9.0	10.0
34048.W1564	Steel	Flat, plain	M6	2.5	3.2	15	9.0	16.0
34048.W2542	Stainless	Flat, plain	M4	0.5	1.8	8	3.5	5.6
34048.W2544	Stainless	Flat, plain	M4	0.5	1.8	8	3.5	9.6
34048.W2552	Stainless	Flat, plain	M5	0.6	2.2	10	4.5	7.5
34048.W2554	Stainless	Flat, plain	M5	1.1	2.2	10	4.5	11.5
34048.W2562	Stainless	Flat, plain	M6	1.5	3.2	15	9.0	10.0
34048.W2564	Stainless	Flat, plain	M6	2.5	3.2	15	9.0	16.0



Thrust Screws - Ball Ended

headless - fine thread - round ball - metal



Thrust Screws

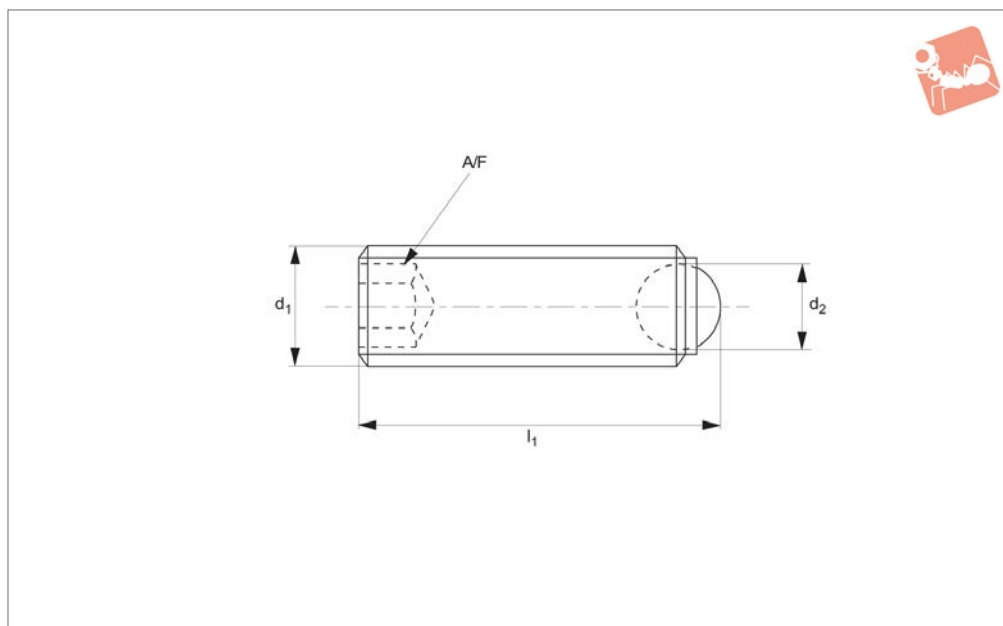

34051

THRUST SCREWS

Material

Steel type-

Body: steel, heat-treated, 1200 ±100 N/mm².

Ball: ball bearing steel, hardened.

Stainless steel type-

Body: stainless steel (AISI 303, 1.4305).

Ball: stainless steel, hardened.

Technical Notes

For clamping, tightening or supporting surfaces that are not exactly parallel.

These ball ended thrust screws have a fine thread, for precise adjustment.

Tips

Ball not secured against rotation. For other types see following pages.

Important Notes

*Max. static load relates to steel version only.

Order No.	Material	Ball type	d ₁	d ₂	l ₁	A/F	Static load kN max.	Weight g
34051.W0030	Steel	Round	M 4x0,35	2.5	6.0	2	3.5	0.4
34051.W0032	Steel	Round	M 4x0,35	2.5	10.0	2	3.5	0.8
34051.W0040	Steel	Round	M 4x0,5	2.5	6.0	2	3.5	0.4
34051.W0042	Steel	Round	M 4x0,5	2.5	6.0	2	3.5	0.4
34051.W0052	Steel	Round	M 5x0,5	3.0	8.0	3	4.5	0.7
34051.W0054	Steel	Round	M 5x0,5	3.0	12.0	3	4.5	1.2
34051.W0062	Steel	Round	M 6x0,5	4.0	10.8	3	9.0	1.3
34051.W0063	Steel	Round	M 6x0,5	4.0	12.8	3	9.0	1.8
34051.W0064	Steel	Round	M 6x0,5	4.0	16.8	3	9.0	2.4
34051.W0065	Steel	Round	M 6x0,5	4.0	20.8	3	9.0	3.0
34051.W0066	Steel	Round	M 6x0,5	4.0	25.8	3	9.0	3.0
34051.W0081	Steel	Round	M 8x1,0	5.5	11.2	4	15.0	2.6
34051.W0084	Steel	Round	M 8x1,0	5.5	21.2	4	15.0	5.4
34051.W0730	Stainless	Round	M 4x0,35	2.5	6.0	2	-	0.4
34051.W0732	Stainless	Round	M 4x0,35	2.5	10.0	2	-	0.8
34051.W0740	Stainless	Round	M 4x0,5	2.5	6.0	2	-	0.4
34051.W0742	Stainless	Round	M 4x0,5	2.5	10.0	2	-	0.8
34051.W0760	Stainless	Round	M 5x0,5	3.0	8.0	3	-	0.7
34051.W0762	Stainless	Round	M 5x0,5	3.0	12.0	3	-	1.2
34051.W0770	Stainless	Round	M 6x0,5	4.0	10.8	3	-	1.3
34051.W0772	Stainless	Round	M 6x0,5	4.0	12.8	3	-	1.8
34051.W0774	Stainless	Round	M 6x0,5	4.0	16.8	3	-	2.4
34051.W0775	Stainless	Round	M 6x0,5	4.0	20.8	3	-	3.0
34051.W0776	Stainless	Round	M 6x0,5	4.0	25.8	3	-	3.0
34051.W0780	Stainless	Round	M 8x1,0	5.5	11.2	4	-	2.6
34051.W0784	Stainless	Round	M 8x1,0	5.5	21.2	4	-	5.4



34053

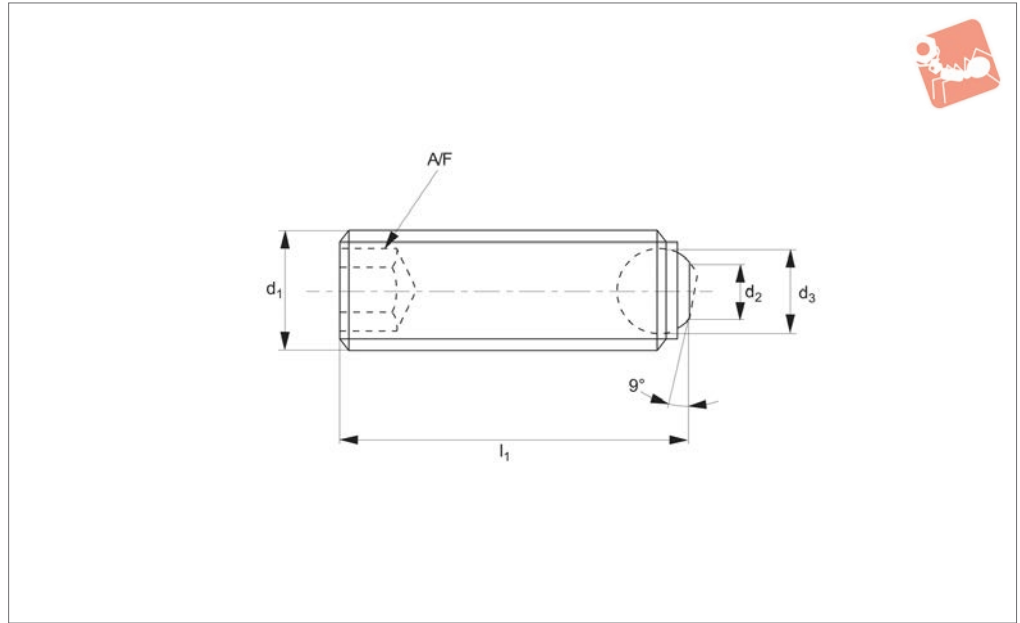

THRUST SCREWS

Material

Steel type-

Body: steel, heat-treated, 1200 ±100 N/mm².

Ball: ball bearing steel, hardened.

Stainless steel type-

Body: stainless steel (AISI 303, 1.4305).

Ball: stainless steel, hardened.

Technical Notes

For clamping, tightening or supporting surfaces that are not exactly parallel.

These ball ended thrust screws have a fine thread, for precise adjustment.

Tips

Ball not secured against rotation. It is

possible for the flat faced ball to flip and expose the spherical face of the ball. For other types see following pages.

Important Notes

*Max static load relates to steel version only.

Order No.	Material	Type	d ₁	d ₂	d ₃	l ₂	A/F	Static load kN max.	Weight g
34053.W0530	Steel	Flat, Plain	M 4x0,35	1.3	2.5	5.6	2	3.5	0.6
34053.W0532	Steel	Flat, Plain	M 4x0,35	1.3	2.5	9.6	2	3.5	0.8
34053.W0540	Steel	Flat, Plain	M 4x0,5	1.3	2.5	5.6	2	3.5	0.4
34053.W0542	Steel	Flat, Plain	M 4x0,5	1.3	2.5	9.6	2	3.5	0.8
34053.W0552	Steel	Flat, Plain	M 5x0,5	2.2	3.0	7.5	3	4.5	0.7
34053.W0554	Steel	Flat, Plain	M 5x0,5	2.2	3.0	11.5	3	4.5	1.2
34053.W0562	Steel	Flat, Plain	M 6x0,5	3.2	4.0	10.0	3	9.0	1.3
34053.W0563	Steel	Flat, Plain	M 6x0,5	3.2	4.0	12.0	3	9.0	1.8
34053.W0564	Steel	Flat, Plain	M 6x0,5	3.2	4.0	16.0	3	9.0	2.4
34053.W0565	Steel	Flat, Plain	M 6x0,5	3.2	4.0	20.0	3	9.0	3.0
34053.W0566	Steel	Flat, Plain	M 6x0,5	3.2	4.0	25.0	3	9.0	3.0
34053.W0581	Steel	Flat, Plain	M 8x1,0	4.5	5.5	10.0	4	15.0	2.6
34053.W0584	Steel	Flat, Plain	M 8x1,0	4.5	5.5	20.0	4	15.0	5.3
34053.W0830	Stainless	Flat, Plain	M 4x0,35	1.3	2.5	5.6	2	-	0.6
34053.W0832	Stainless	Flat, Plain	M 4x0,35	1.3	2.5	9.6	2	-	0.8
34053.W0838	Stainless	Flat, Plain	M 4x0,5	1.3	2.5	5.6	2	-	0.4
34053.W0839	Stainless	Flat, Plain	M 4x0,5	1.3	2.5	9.6	2	-	0.8
34053.W0833	Stainless	Flat, Plain	M 5x0,5	2.2	3.0	7.5	3	-	0.7
34053.W0835	Stainless	Flat, Plain	M 5x0,5	2.2	3.0	11.5	3	-	1.2
34053.W0840	Stainless	Flat, Plain	M 6x0,5	3.2	4.0	10.0	3	-	1.3
34053.W0842	Stainless	Flat, Plain	M 6x0,5	3.2	4.0	12.0	3	-	1.8
34053.W0844	Stainless	Flat, Plain	M 6x0,5	3.2	4.0	16.0	3	-	2.4
34053.W0845	Stainless	Flat, Plain	M 6x0,5	3.2	4.0	20.0	3	-	3.0
34053.W0846	Stainless	Flat, Plain	M 6x0,5	3.2	4.0	25.0	3	-	3.0
34053.W0850	Stainless	Flat, Plain	M 8x1,0	4.5	5.5	10.0	4	-	2.6
34053.W0854	Stainless	Flat, Plain	M 8x1,0	4.5	5.5	20.0	4	-	5.3



Thrust Screws - Ball Ended

headless - fine thread - flat faced ball - metal



Thrust Screws



THRUST SCREWS



34060

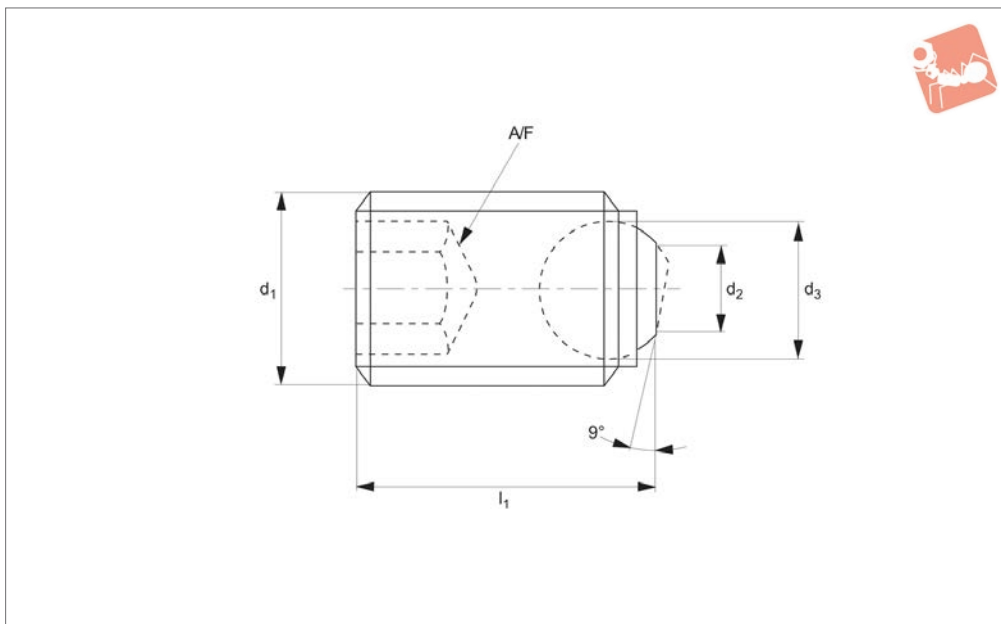

Material

Body: steel, heat-treated, $1200 \pm 100 \text{ N/mm}^2$.

Ball: ball bearing steel, hardened.

Technical Notes

These short ball ended thrust screws are

particularly suited for use with parallel shanks DIN 1835E, in combination with either Whistle Notch or Weldon Tool Holding fixtures.

Maximised load transmission due to movable ball.

Order No.	Ball type	d_1	d_2	d_3	l_1	A/F	Static load kN max.	Weight g
34060.W0641	Flat, Plain	M14	7.2	8.5	16	6	30	13
34060.W0660	Flat, Plain	M16	7.2	8.5	16	8	30	16
34060.W0682	Flat, Plain	M18x2	10.7	12.0	20	10	60	25
34060.W0692	Flat, Plain	M20x2	10.7	12.0	20	10	60	32
34060.W0693	Flat, Plain	M20x2	10.7	12.0	25	10	60	42
34060.W0730	Flat, Plain	M24x2	13.5	15.0	25	12	90	59

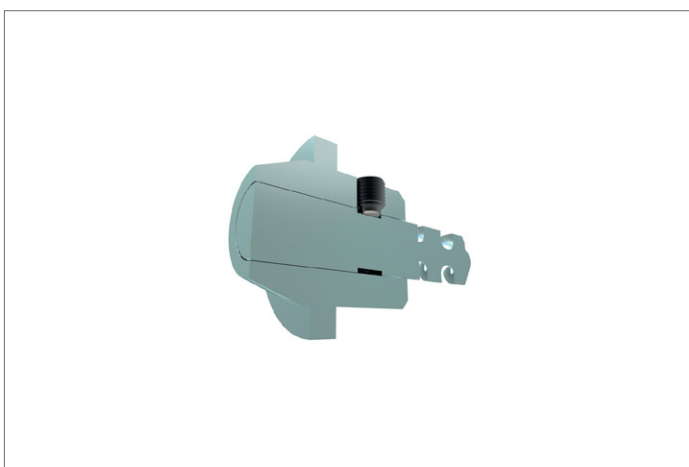

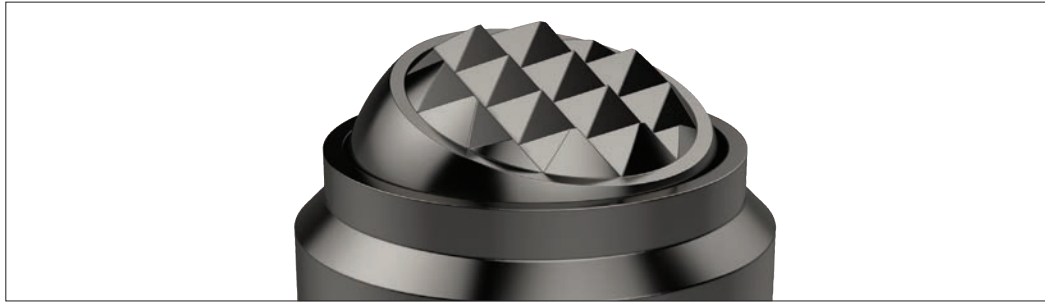

Clamping, supporting and aligning non-parallel and uneven surfaces is greatly simplified with the use of Wixroyd self-aligning pads and thrust screws. Available with ridged faces for improved holding of cast components, or plastic faces for holding more delicate parts.



Self-aligning Thrust Screws

34000 to 34060 - Self-aligning thrust screws in sizes M6 to M24, ideal for clamping or supporting non-parallel surfaces.

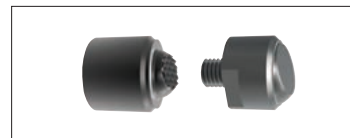
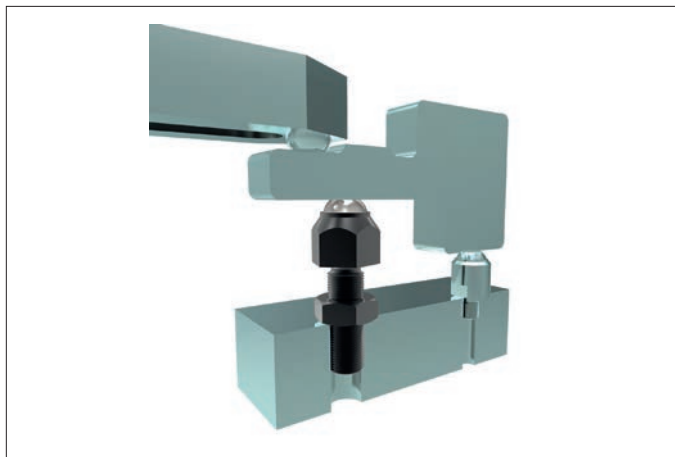

Self-aligning Pads

34080 to 34121 - Self-aligning pads, both male and female mounting, ideal for accommodating variations between parts in fixtures.

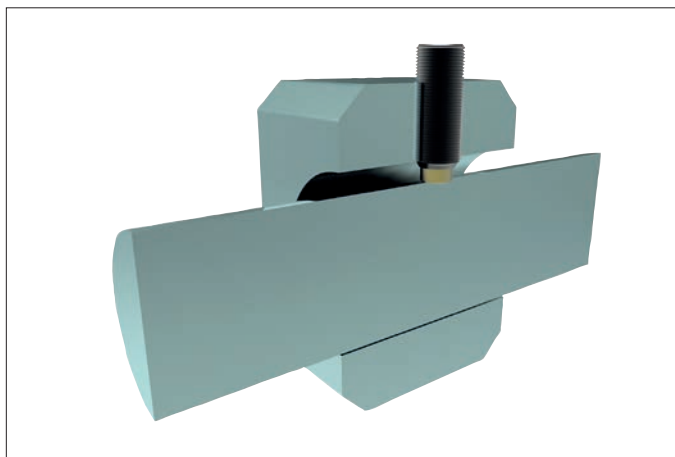
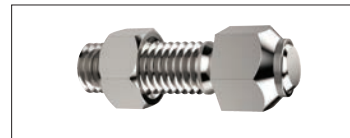
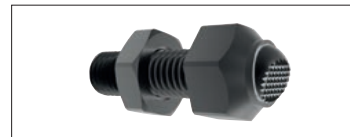

Thrust Screws

34140 to 34160 - Thrust screws, with either brass or thermoplastic pads, are suitable for gentle clamping and positioning more delicate parts.



THRUST SCREWS

ov-W34000-A-T-W34160.2-AP0124-T-self-aligning-pads-and-thrust-screws-a-rmh - Updated - 28-10-2022



34042

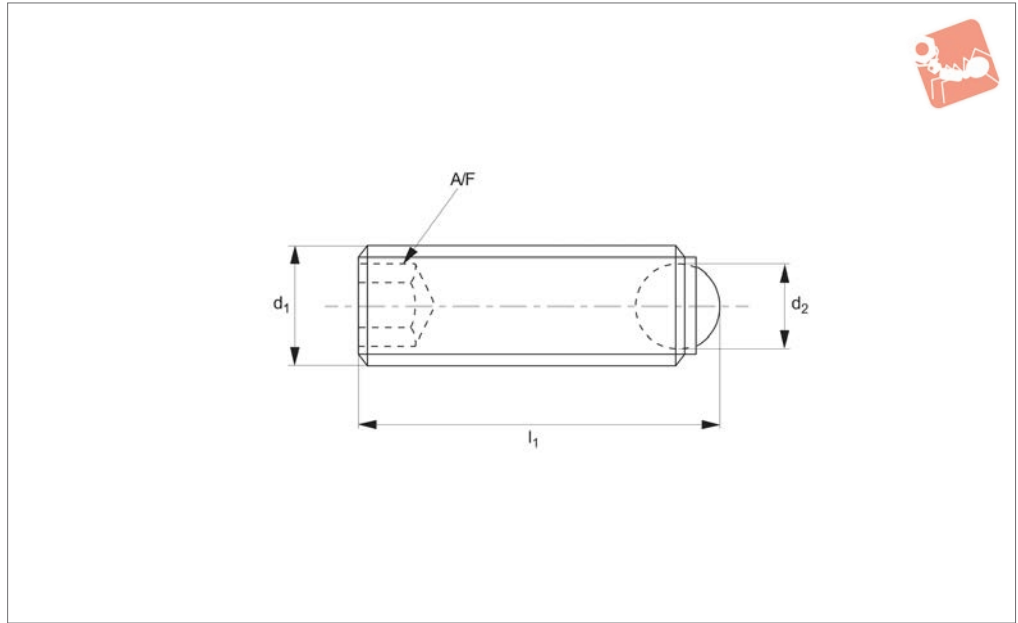

THRUST SCREWS

Material

Steel type-

Body: steel, heat-treated, 1200 ±100 N/mm².

Ball: thermoplastic POM, white.

Stainless steel type-

Body: stainless steel (AISI 303, 1.4305).

Ball: thermoplastic POM, white.

Technical Notes

Ball-ended thrust screws with thermoplastic balls are used for brittle, pressure sensitive parts. For clamping, tightening or supporting surfaces that are not exactly

parallel.

Max temperature -30°C to 80°C.

Tips

Ball not secured against rotation. For other types see following pages.

Order No.	Material	Ball type	d ₁	d ₂	l ₁	A/F	Static load kN max.	Weight g
34042.W0252	Stainless	Round	M 4	2.5	6.0	2.0	0.3	0.2
34042.W0253	Stainless	Round	M 4	2.5	8.0	2.0	0.3	0.4
34042.W0254	Stainless	Round	M 4	2.5	10.0	2.0	0.3	0.7
34042.W0255	Stainless	Round	M 4	2.5	12.0	2.0	0.3	0.9
34042.W0256	Stainless	Round	M 4	2.5	16.0	2.0	0.3	1.1
34042.W0262	Stainless	Round	M 5	3.0	8.0	2.5	0.5	0.8
34042.W0263	Stainless	Round	M 5	3.0	10.0	2.5	0.5	0.8
34042.W0264	Stainless	Round	M 5	3.0	12.0	2.5	0.5	1.2
34042.W0265	Stainless	Round	M 5	3.0	16.0	2.5	0.5	1.4
34042.W0266	Stainless	Round	M 5	3.0	20.0	2.5	0.5	1.9
34042.W0267	Stainless	Round	M 5	3.0	25.0	2.5	0.5	2.5
34042.W0272	Stainless	Round	M 6	4.0	10.8	3.0	0.9	1.1
34042.W0273	Stainless	Round	M 6	4.0	12.8	3.0	0.9	1.4
34042.W0274	Stainless	Round	M 6	4.0	16.8	3.0	0.9	2.1
34042.W0275	Stainless	Round	M 6	4.0	20.8	3.0	0.9	2.8
34042.W0276	Stainless	Round	M 6	4.0	25.8	3.0	0.9	3.8
34042.W0281	Stainless	Round	M 8	5.5	11.2	4.0	1.5	1.9
34042.W0282	Stainless	Round	M 8	5.5	13.2	4.0	1.5	2.4
34042.W0283	Stainless	Round	M 8	5.5	17.2	4.0	1.5	3.6
34042.W0284	Stainless	Round	M 8	5.5	21.2	4.0	1.5	4.6
34042.W0285	Stainless	Round	M 8	5.5	26.2	4.0	1.5	6.3
34042.W0286	Stainless	Round	M 8	5.5	31.2	4.0	1.5	7.8
34042.W0291	Stainless	Round	M10	7.0	13.7	5.0	2.0	3.5
34042.W0292	Stainless	Round	M10	7.0	17.7	5.0	2.0	4.8
34042.W0293	Stainless	Round	M10	7.0	21.7	5.0	2.0	6.8
34042.W0294	Stainless	Round	M10	7.0	26.7	5.0	2.0	9.4
34042.W0295	Stainless	Round	M10	7.0	31.7	5.0	2.0	12.0
34042.W0296	Stainless	Round	M10	7.0	36.7	5.0	2.0	14.0
34042.W0297	Stainless	Round	M10	7.0	41.7	5.0	2.0	17.
34042.W0301	Stainless	Round	M12	8.5	18.0	6.0	3.0	6.8



Thrust Screws - Ball Ended

headless - round ball - thermoplastic



Thrust Screws

Order No.	Material	Ball type	d ₁	d ₂	l ₁	A/F	Static load kN max.	Weight g
34042.W0302	Stainless	Round	M12	8.5	22.0	6.0	3.0	9.2
34042.W0303	Stainless	Round	M12	8.5	27.0	6.0	3.0	12.0
34042.W0304	Stainless	Round	M12	8.5	32.0	6.0	3.0	16.0
34042.W0306	Stainless	Round	M12	8.5	42.0	6.0	3.0	23.0
34042.W0308	Stainless	Round	M12	8.5	52.0	6.0	3.0	30.0
34042.W0342	Steel	Round	M 4	2.5	6.0	2.0	0.3	0.2
34042.W0343	Steel	Round	M 4	2.5	8.0	2.0	0.3	0.4
34042.W0344	Steel	Round	M 4	2.5	10.0	2.0	0.3	0.7
34042.W0345	Steel	Round	M 4	2.5	12.0	2.0	0.3	0.9
34042.W0346	Steel	Round	M 4	2.5	16.0	2.0	0.3	1.1
34042.W0352	Steel	Round	M 5	3.0	8.0	2.5	0.5	0.8
34042.W0353	Steel	Round	M 5	3.0	10.0	2.5	0.5	0.8
34042.W0354	Steel	Round	M 5	3.0	12.0	2.5	0.5	1.2
34042.W0355	Steel	Round	M 5	3.0	16.0	2.5	0.5	1.4
34042.W0356	Steel	Round	M 5	3.0	20.0	2.5	0.5	1.9
34042.W0358	Steel	Round	M 5	3.0	25.0	2.5	0.5	2.5
34042.W0362	Steel	Round	M 6	4.0	10.8	3.0	0.9	1.1
34042.W0363	Steel	Round	M 6	4.0	12.8	3.0	0.9	1.4
34042.W0364	Steel	Round	M 6	4.0	16.8	3.0	0.9	2.1
34042.W0365	Steel	Round	M 6	4.0	20.8	3.0	0.9	2.7
34042.W0366	Steel	Round	M 6	4.0	25.8	3.0	0.9	3.8
34042.W0381	Steel	Round	M 8	5.5	11.2	4.0	1.5	1.9
34042.W0382	Steel	Round	M 8	5.5	13.2	4.0	1.5	2.4
34042.W0383	Steel	Round	M 8	5.5	17.2	4.0	1.5	3.6
34042.W0384	Steel	Round	M 8	5.5	21.2	4.0	1.5	4.6
34042.W0385	Steel	Round	M 8	5.5	26.2	4.0	1.5	6.3
34042.W0386	Steel	Round	M 8	5.5	31.2	4.0	1.5	7.8
34042.W0401	Steel	Round	M10	7.0	13.7	5.0	2.0	3.5
34042.W0402	Steel	Round	M10	7.0	17.7	5.0	2.0	4.8
34042.W0403	Steel	Round	M10	7.0	21.7	5.0	2.0	6.8
34042.W0404	Steel	Round	M10	7.0	26.7	5.0	2.0	9.4
34042.W0405	Steel	Round	M10	7.0	31.7	5.0	2.0	12.0
34042.W0406	Steel	Round	M10	7.0	36.7	5.0	2.0	14.0
34042.W0408	Steel	Round	M10	7.0	41.7	5.0	2.0	17.0
34042.W0421	Steel	Round	M12	8.5	18.0	6.0	3.0	6.8
34042.W0422	Steel	Round	M12	8.5	22.0	6.0	3.0	9.2
34042.W0423	Steel	Round	M12	8.5	27.0	6.0	3.0	12.0
34042.W0424	Steel	Round	M12	8.5	32.0	6.0	3.0	16.0
34042.W0426	Steel	Round	M12	8.5	42.0	6.0	3.0	23.0
34042.W0428	Steel	Round	M12	8.5	52.0	6.0	3.0	30.0

THRUST SCREWS

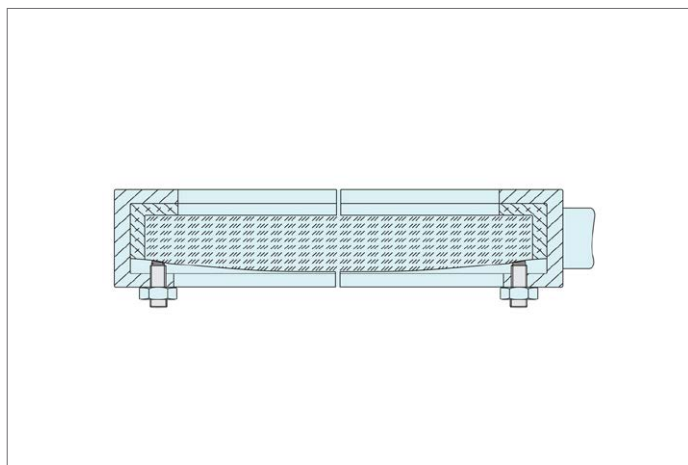



34044

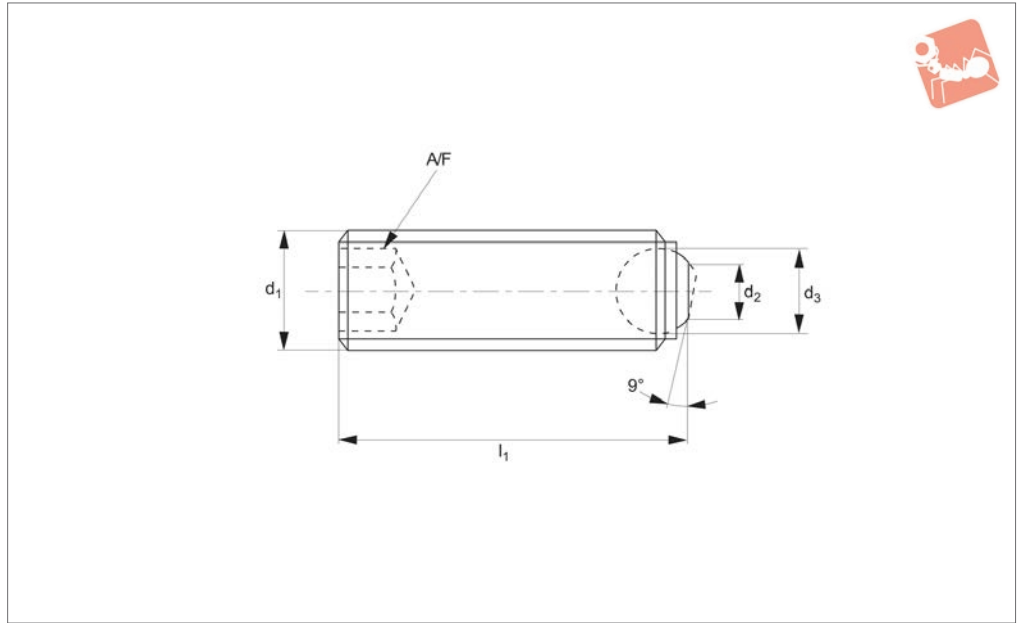

THRUST SCREWS

Material

Body: steel, heat-treated, 1200 ±100 N/mm².

Ball: ball bearing steel, hardened.

Technical Notes

For clamping, tightening or supporting of

surfaces that are not exactly parallel.
Max. operating temperature 250°C.

Tips

Ball not secured against rotation. It is possible for the flat faced ball to flip and expose the spherical face of the ball. For

other types see following pages.

Order No.	Ball type	d ₁	d ₂	d ₃	l ₁	A/F	Static load kN max.	Weight g
34044.W0891	Flat, Ribbed	M 8	4.5	5.5	10	4	15	3
34044.W0892	Flat, Ribbed	M 8	4.5	5.5	12	4	15	3
34044.W0893	Flat, Ribbed	M 8	4.5	5.5	16	4	15	4
34044.W0894	Flat, Ribbed	M 8	4.5	5.5	20	4	15	5
34044.W0895	Flat, Ribbed	M 8	4.5	5.5	25	4	15	7
34044.W0896	Flat, Ribbed	M 8	4.5	5.5	30	4	15	8
34044.W0901	Flat, Ribbed	M10	6.0	7.0	12	5	20	5
34044.W0902	Flat, Ribbed	M10	6.0	7.0	16	5	20	6
34044.W0903	Flat, Ribbed	M10	6.0	7.0	20	5	20	8
34044.W0904	Flat, Ribbed	M10	6.0	7.0	25	5	20	10
34044.W0905	Flat, Ribbed	M10	6.0	7.0	30	5	20	13
34044.W0906	Flat, Ribbed	M10	6.0	7.0	35	5	20	15
34044.W0908	Flat, Ribbed	M10	6.0	7.0	40	5	20	17
34044.W0921	Flat, Ribbed	M12	7.2	8.5	16	6	30	9
34044.W0922	Flat, Ribbed	M12	7.2	8.5	20	6	30	11
34044.W0923	Flat, Ribbed	M12	7.2	8.5	25	6	30	14
34044.W0924	Flat, Ribbed	M12	7.2	8.5	30	6	30	18
34044.W0926	Flat, Ribbed	M12	7.2	8.5	40	6	30	25
34044.W0928	Flat, Ribbed	M12	7.2	8.5	50	6	30	32
34044.W0961	Flat, Ribbed	M16	10.7	12	20	8	60	21
34044.W0962	Flat, Ribbed	M16	10.7	12	25	8	60	26
34044.W0964	Flat, Ribbed	M16	10.7	12	35	8	60	40
34044.W0966	Flat, Ribbed	M16	10.7	12	50	8	60	60
34044.W0972	Flat, Ribbed	M20	13.5	15	30	10	90	50
34044.W0974	Flat, Ribbed	M20	13.5	15	40	10	90	70
34044.W0975	Flat, Ribbed	M20	13.5	15	50	10	90	89
34044.W0976	Flat, Ribbed	M20	13.5	15	60	10	90	111
34044.W0982	Flat, Ribbed	M24	15.8	18	35	12	120	84
34044.W0984	Flat, Ribbed	M24	15.8	18	50	12	120	125
34044.W0986	Flat, Ribbed	M24	15.5	18	80	12	120	219



Thrust Screws - Ball Ended

headless - flat faced ball - thermoplastic



Thrust Screws

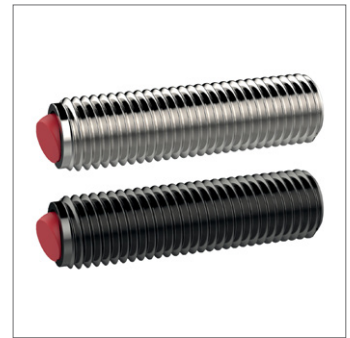
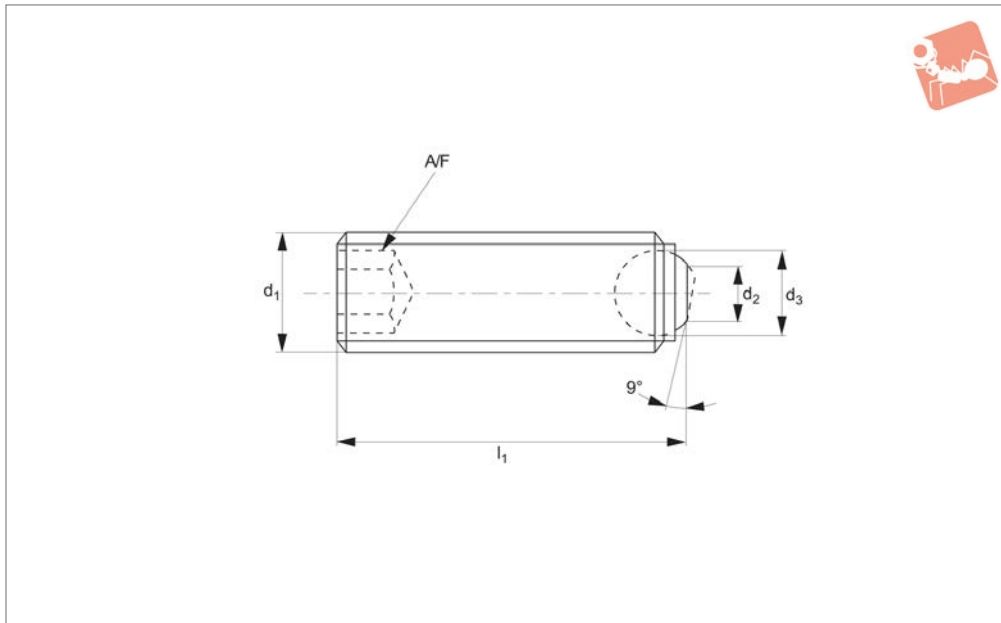

34045

THRUST SCREWS

Material

Steel type-

Body: steel, heat-treated, 1200 ±100 N/mm².

Ball: thermoplastic, red (POM).

Stainless steel type-

Body: stainless steel (AISI 303, 1.4305).

Ball: thermoplastic, red (POM).

Technical Notes

Ball-ended thrust screws with thermoplastic balls are used for brittle, pressure sensitive parts. For clamping, tightening or supporting surfaces that are not exactly

parallel.

Tips

Ball not secured against rotation. It is possible for the flat faced ball to flip and expose the spherical pace of the ball.

Order No.	Material	Type	d ₁	d ₂	d ₃	l ₁	A/F	Static load kN max.	Weight g
34045.W0452	Steel	Flat, Plain	M 4	1.8	2.5	5.9	2	0.3	0.2
34045.W0453	Steel	Flat, Plain	M 4	1.8	2.5	7.9	2	0.3	0.4
34045.W0454	Steel	Flat, Plain	M 4	1.8	2.5	9.9	2	0.3	0.5
34045.W0455	Steel	Flat, Plain	M 4	1.8	2.5	11.9	2	0.3	0.9
34045.W0456	Steel	Flat, Plain	M 4	1.8	2.5	15.9	2	0.3	0.9
34045.W0462	Steel	Flat, Plain	M 5	2.1	3.0	7.8	3	0.5	0.8
34045.W0463	Steel	Flat, Plain	M 5	2.1	3.0	9.8	3	0.5	0.7
34045.W0464	Steel	Flat, Plain	M 5	2.1	3.0	11.8	3	0.5	1.2
34045.W0465	Steel	Flat, Plain	M 5	2.1	3.0	15.8	3	0.5	1.4
34045.W0466	Steel	Flat, Plain	M 5	2.1	3.0	19.8	3	0.5	2.0
34045.W0467	Steel	Flat, Plain	M 5	2.1	3.0	24.8	3	0.5	2.7
34045.W0472	Steel	Flat, Plain	M 6	3.0	4.0	10.3	3	0.9	1.1
34045.W0473	Steel	Flat, Plain	M 6	3.0	4.0	12.3	3	0.9	1.7
34045.W0474	Steel	Flat, Plain	M 6	3.0	4.0	16.3	3	0.9	2.1
34045.W0475	Steel	Flat, Plain	M 6	3.0	4.0	20.3	3	0.9	2.8
34045.W0476	Steel	Flat, Plain	M 6	3.0	4.0	25.3	3	0.9	3.6
34045.W0482	Steel	Flat, Plain	M 8	4.2	5.5	10.4	4	1.5	1.8
34045.W0483	Steel	Flat, Plain	M 8	4.2	5.5	12.4	4	1.5	2.2
34045.W0484	Steel	Flat, Plain	M 8	4.2	5.5	16.4	4	1.5	3.4
34045.W0485	Steel	Flat, Plain	M 8	4.2	5.5	20.4	4	1.5	4.8
34045.W0486	Steel	Flat, Plain	M 8	4.2	5.5	25.4	4	1.5	6.1
34045.W0487	Steel	Flat, Plain	M 8	4.2	5.5	30.4	4	1.5	7.6
34045.W0492	Stainless	Flat, Plain	M 4	1.8	2.5	5.9	2	0.3	0.2
34045.W0493	Stainless	Flat, Plain	M 4	1.8	2.5	7.9	2	0.3	0.4
34045.W0494	Stainless	Flat, Plain	M 4	1.8	2.5	9.9	2	0.3	0.5
34045.W0495	Stainless	Flat, Plain	M 4	1.8	2.5	11.9	2	0.3	0.9
34045.W0496	Stainless	Flat, Plain	M 4	1.8	2.5	15.9	2	0.3	0.9
34045.W0502	Stainless	Flat, Plain	M 5	2.1	3.0	7.8	3	0.5	0.8
34045.W0503	Stainless	Flat, Plain	M 5	2.1	3.0	9.8	3	0.5	0.7
34045.W0504	Stainless	Flat, Plain	M 5	2.1	3.0	11.8	3	0.5	1.2



Order No.	Material	Type	d ₁	d ₂	d ₃	l ₁	A/F	Static load kN max.	Weight g
34045.W0505	Stainless	Flat, Plain	M 5	2.1	3.0	15.8	3	0.5	1.4
34045.W0506	Stainless	Flat, Plain	M 5	2.1	3.0	19.8	3	0.5	2.0
34045.W0507	Stainless	Flat, Plain	M 5	2.1	3.0	24.8	3	0.5	2.7
34045.W0512	Stainless	Flat, Plain	M 6	3.0	4.0	10.3	3	0.9	1.1
34045.W0513	Stainless	Flat, Plain	M 6	3.0	4.0	12.3	3	0.9	1.7
34045.W0514	Stainless	Flat, Plain	M 6	3.0	4.0	16.3	3	0.9	2.1
34045.W0515	Stainless	Flat, Plain	M 6	3.0	4.0	20.3	3	0.9	2.8
34045.W0516	Stainless	Flat, Plain	M 6	3.0	4.0	25.3	3	0.9	3.6
34045.W0522	Stainless	Flat, Plain	M 8	4.2	5.5	10.4	4	1.5	1.8
34045.W0523	Stainless	Flat, Plain	M 8	4.2	5.5	12.4	4	1.5	2.2
34045.W0524	Stainless	Flat, Plain	M 8	4.2	5.5	16.4	4	1.5	3.4
34045.W0525	Stainless	Flat, Plain	M 8	4.2	5.5	20.4	4	1.5	4.8
34045.W0526	Stainless	Flat, Plain	M 8	4.2	5.5	25.4	4	1.5	6.1
34045.W0527	Stainless	Flat, Plain	M 8	4.2	5.5	30.4	4	1.5	7.6



Thrust Screws - Headed ball ended - metal

Thrust Screws

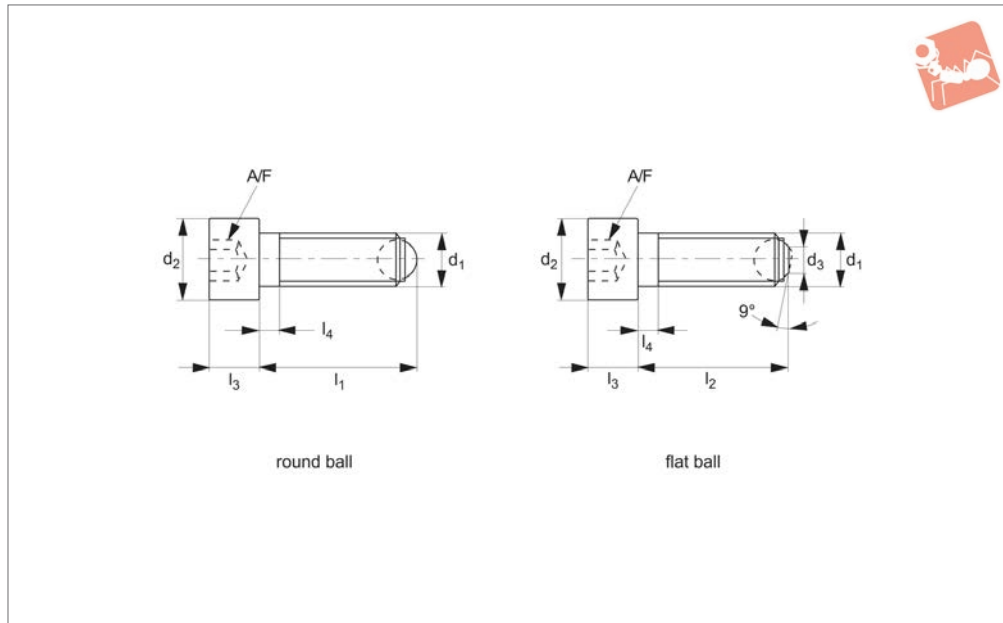

34020

THRUST SCREWS

Material

Steel type-

Body: heat treated steel, 1200 +/-100 N/mm².

Ball: ball bearing steel, hardened.

Stainless steel type-

Body: stainless steel 1.4305 (AISI 303).

Ball: stainless steel, hardened.

Technical Notes

For thrust screws secured against turning - see no. 34000/X34000#26 or 34002. For clamping, tightening or supporting surfaces that are not exactly parallel.

* stated load capacity relate to steel version only.

Tips

Ball not secured against rotation, it is possible for the flat faced ball to flip and expose the spherical face of the ball.

Order No.	Material	Ball face type	d ₁	l ₁	l ₂	d ₂	d ₃	l ₃	l ₄	Ball dia.	A/F	Static load kN max.	Weight g
34020.W0062	Steel	Round	M_6	20.8	-	10	-	6	3.0	4.0	5	9	6.2
34020.W0064	Steel	Round	M_6	30.8	-	10	-	6	3.0	4.0	5	9	8.0
34020.W0066	Steel	Round	M_6	40.8	-	10	-	6	16.0	4.0	5	9	10.0
34020.W0082	Steel	Round	M_8	21.2	-	13	-	8	3.5	5.5	6	15	13.0
34020.W0084	Steel	Round	M_8	36.2	-	13	-	8	3.5	5.5	6	15	17.0
34020.W0086	Steel	Round	M_8	51.2	-	13	-	8	22.0	5.5	6	15	24.0
34020.W0102	Steel	Round	M10	26.7	-	16	-	10	4.5	7.0	8	20	24.0
34020.W0104	Steel	Round	M10	41.7	-	16	-	10	4.5	7.0	8	20	31.0
34020.W0106	Steel	Round	M10	61.7	-	16	-	10	28.0	7.0	8	20	44.0
34020.W0122	Steel	Round	M12	32.0	-	18	-	12	5.0	8.5	10	30	38.0
34020.W0124	Steel	Round	M12	52.0	-	18	-	12	5.0	8.5	10	30	52.0
34020.W0126	Steel	Round	M12	82.0	-	18	-	12	44.0	8.5	10	30	79.0
34020.W0162	Steel	Round	M16	43.3	-	24	-	16	6.0	12.0	14	60	94.0
34020.W0164	Steel	Round	M16	63.3	-	24	-	16	6.0	12.0	14	60	119.0
34020.W0166	Steel	Round	M16	83.3	-	24	-	16	36.0	12.0	14	60	156.0
34020.W0202	Steel	Round	M20	54.2	-	30	-	20	7.5	15.0	17	90	183.0
34020.W0204	Steel	Round	M20	84.2	-	30	-	20	28.0	15.0	17	90	254.0
34020.W0206	Steel	Round	M20	104.2	-	30	-	20	48.0	15.0	17	90	307.0
34020.W0242	Steel	Round	M24	64.7	-	36	-	24	9.0	18.0	19	120	331.0
34020.W0244	Steel	Round	M24	94.7	-	36	-	24	30.0	18.0	19	120	430.0
34020.W0246	Steel	Round	M24	124.7	-	36	-	24	60.0	18.0	19	120	537.0
34020.W0562	Steel	Flat, Plain	M_6	-	20.0	10	3.2	6	3.0	4.0	5	9	6.1
34020.W0564	Steel	Flat, Plain	M_6	-	30.0	10	3.2	6	3.0	4.0	5	9	7.6
34020.W0566	Steel	Flat, Plain	M_6	-	40.0	10	3.2	6	16.0	4.0	5	9	10.0
34020.W0582	Steel	Flat, Plain	M_8	-	20.0	13	4.5	8	3.5	5.5	6	15	13.0
34020.W0584	Steel	Flat, Plain	M_8	-	35.0	13	4.5	8	3.5	5.5	6	15	17.0
34020.W0586	Steel	Flat, Plain	M_8	-	50.0	13	4.5	8	22.0	5.5	6	15	23.0
34020.W0602	Steel	Flat, Plain	M10	-	25.0	16	6.0	10	4.5	7.0	8	20	24.0
34020.W0604	Steel	Flat, Plain	M10	-	40.0	16	6.0	10	4.5	7.0	8	20	31.0
34020.W0606	Steel	Flat, Plain	M10	-	60.0	16	6.0	10	28.0	7.0	8	20	43.0



Order No.	Material	Ball face type	d ₁	l ₁	l ₂	d ₂	d ₃	l ₃	l ₄	Ball dia.	A/F	Static load kN max.	Weight g
34020.W0622	Steel	Flat, Plain	M12	-	30.0	18	7.2	12	5.0	8.5	10	30	38.0
34020.W0624	Steel	Flat, Plain	M12	-	50.0	18	7.2	12	5.0	8.5	10	30	52.0
34020.W0626	Steel	Flat, Plain	M12	-	80.0	18	7.2	12	44.0	8.5	10	30	79.0
34020.W0662	Steel	Flat, Plain	M16	-	40.0	24	10.7	16	6.0	12.0	14	60	92.0
34020.W0664	Steel	Flat, Plain	M16	-	60.0	24	10.7	16	6.0	12.0	14	60	120.0
34020.W0666	Steel	Flat, Plain	M16	-	80.0	24	10.7	16	36.0	12.0	14	60	155.0
34020.W0702	Steel	Flat, Plain	M20	-	50.0	30	13.5	20	7.5	15.0	17	90	182.0
34020.W0704	Steel	Flat, Plain	M20	-	80.0	30	13.5	20	28.0	15.0	17	90	255.0
34020.W0706	Steel	Flat, Plain	M20	-	100.0	30	13.5	20	48.0	15.0	17	90	305.0
34020.W0742	Steel	Flat, Plain	M24	-	60.0	36	15.8	24	9.0	18.0	19	120	325.0
34020.W0744	Steel	Flat, Plain	M24	-	90.0	36	15.8	24	30.0	18.0	19	120	422.0
34020.W0746	Steel	Flat, Plain	M24	-	120.0	36	15.8	24	60.0	18.0	19	120	534.0
34020.W0752	Stainless	Round	M_6	20.8	-	10	-	6	3.0	4.0	5	9	6.2
34020.W0754	Stainless	Round	M_6	30.8	-	10	-	6	3.0	4.0	5	9	8.0
34020.W0756	Stainless	Round	M_6	40.8	-	10	-	6	16.0	4.0	5	9	10.0
34020.W0762	Stainless	Round	M_8	21.2	-	13	-	8	3.5	5.5	6	15	13.0
34020.W0764	Stainless	Round	M_8	36.2	-	13	-	8	3.5	5.5	6	15	17.0
34020.W0766	Stainless	Round	M_8	51.2	-	13	-	8	22.0	5.5	6	15	24.0
34020.W0772	Stainless	Round	M10	26.7	-	16	-	10	4.5	7.0	8	20	24.0
34020.W0774	Stainless	Round	M10	41.7	-	16	-	10	4.5	7.0	8	20	31.0
34020.W0776	Stainless	Round	M10	61.7	-	16	-	10	28.0	7.0	8	20	44.0
34020.W0782	Stainless	Round	M12	32.0	-	18	-	12	5.0	8.5	10	30	38.0
34020.W0784	Stainless	Round	M12	52.0	-	18	-	12	5.0	8.5	10	30	52.0
34020.W0786	Stainless	Round	M12	82.0	-	18	-	12	44.0	8.5	10	30	79.0
34020.W0792	Stainless	Round	M16	43.3	-	24	-	16	6.0	12.0	14	60	94.0
34020.W0794	Stainless	Round	M16	63.3	-	24	-	16	6.0	12.0	14	60	119.0
34020.W0796	Stainless	Round	M16	83.3	-	24	-	16	36.0	12.0	14	60	156.0
34020.W0832	Stainless	Flat, Plain	M_6	-	20.0	10	3.2	6	3.0	4.0	5	9	6.1
34020.W0834	Stainless	Flat, Plain	M_6	-	30.0	10	3.2	6	3.0	4.0	5	9	7.6
34020.W0836	Stainless	Flat, Plain	M_6	-	40.0	10	3.2	6	16.0	4.0	5	9	10.0
34020.W0842	Stainless	Flat, Plain	M_8	-	20.0	13	4.5	8	3.5	5.5	6	15	13.0
34020.W0844	Stainless	Flat, Plain	M_8	-	35.0	13	4.5	8	3.5	5.5	6	15	17.0
34020.W0846	Stainless	Flat, Plain	M_8	-	50.0	13	4.5	8	22.0	5.5	6	15	23.0
34020.W0852	Stainless	Flat, Plain	M10	-	25.0	16	6.0	10	4.5	7.0	8	20	24.0
34020.W0854	Stainless	Flat, Plain	M10	-	40.0	16	6.0	10	4.5	8	8	20	31.0
34020.W0856	Stainless	Flat, Plain	M10	-	60.0	16	6.0	10	28.0	7.0	8	20	44.0
34020.W0862	Stainless	Flat, Plain	M12	-	30.0	18	7.2	12	5.0	8.5	10	30	38.0
34020.W0864	Stainless	Flat, Plain	M12	-	50.0	18	7.2	12	5.0	8.5	10	30	52.0
34020.W0866	Stainless	Flat, Plain	M12	-	80.0	18	7.2	12	44.0	8.5	10	30	79.0
34020.W0872	Stainless	Flat, Plain	M16	-	40.0	24	10.7	16	6.0	12.0	14	60	92.0
34020.W0874	Stainless	Flat, Plain	M16	-	60.0	24	10.7	16	6.0	12.0	14	60	120.0
34020.W0876	Stainless	Flat, Plain	M16	-	80.0	24	10.7	16	36.0	12.0	14	60	155.0
34020.W0892	Steel	Flat, Ribbed	M 8	-	20.0	13	4.5	8	3.5	5.5	6	15	12.0
34020.W0894	Steel	Flat, Ribbed	M 8	-	35.0	13	4.5	8	3.5	5.5	6	15	17.0
34020.W0896	Steel	Flat, Ribbed	M 8	-	50.0	13	4.5	8	22.0	5.5	6	15	23.0
34020.W0904	Steel	Flat, Ribbed	M10	-	40.0	16	6.0	10	4.5	7.0	8	20	31.0
34020.W0906	Steel	Flat, Ribbed	M10	-	60.0	16	6.0	10	28.0	7.0	8	20	44.0
34020.W0922	Steel	Flat, Ribbed	M12	-	30.0	18	7.2	12	5.0	8.5	10	30	39.0
34020.W0924	Steel	Flat, Ribbed	M12	-	50.0	18	7.2	12	5.0	8.5	10	30	53.0
34020.W0926	Steel	Flat, Ribbed	M12	-	80.0	18	7.2	12	44.0	8.5	10	30	79.0
34020.W0962	Steel	Flat, Ribbed	M16	-	40.0	24	10.7	16	6.0	12.0	14	60	92.0
34020.W0964	Steel	Flat, Ribbed	M16	-	60.0	24	10.7	16	6.0	12.0	14	60	118.0
34020.W0966	Steel	Flat, Ribbed	M16	-	80.0	24	10.7	16	36.0	12.0	14	60	155.0
34020.W0972	Steel	Flat, Ribbed	M20	-	50.0	30	13.5	20	7.5	15.0	17	90	180.0
34020.W0974	Steel	Flat, Ribbed	M20	-	80.0	30	13.5	20	28.0	15.0	17	90	254.0
34020.W0976	Steel	Flat, Ribbed	M20	-	100.0	30	13.5	20	48.0	15.0	17	90	303.0
34020.W0982	Steel	Flat, Ribbed	M24	-	60.0	36	15.8	24	9.0	18.0	19	120	324.0
34020.W0984	Steel	Flat, Ribbed	M24	-	90.0	36	15.8	24	30.0	18.0	19	120	427.0
34020.W0986	Steel	Flat, Ribbed	M24	-	120.0	36	15.8	24	60.0	18.0	19	120	536.0



Thrust Screws - Steel

ball ended - flat - metal - secured

Thrust Screws

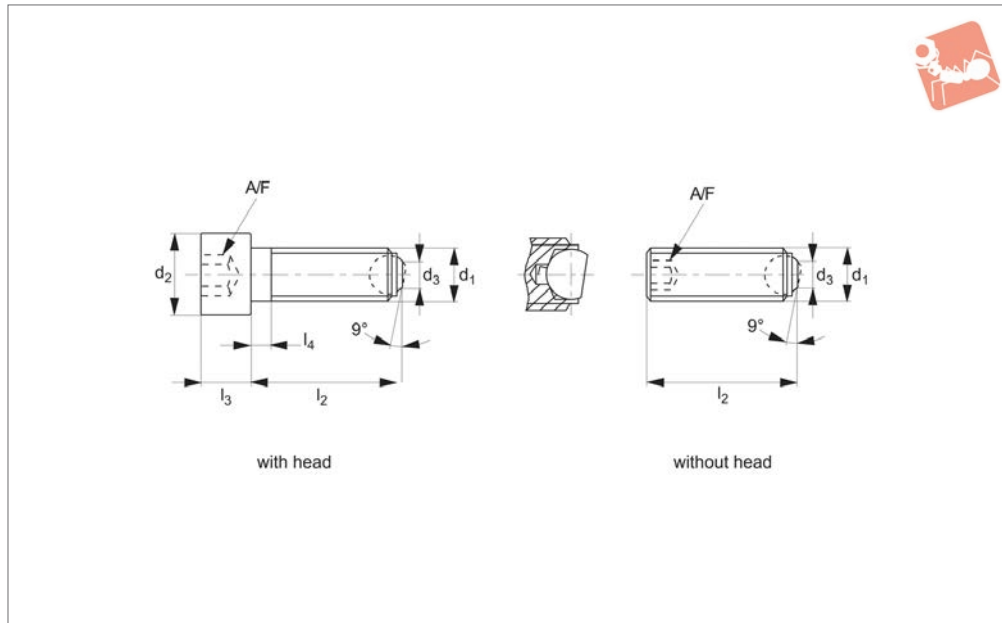

34000

THRUST SCREWS

Material

Body: heat treated steel, 1200 +/-100 N/mm².

Ball: ball bearing steel, hardened.

Technical Notes

For clamping, tightening or supporting of

surfaces that are not exactly parallel.

Special finish in stainless steel possible, price and delivery on request.

Tips

Ball secured against rotation so the flat face ball cannot flip over - see technical

diagram.

Order No.	Type	Ball face	d ₁	l ₂	d ₂	d ₃	l ₃	l ₄	Ball dia.	A/F	Static load kN max.	Weight g
34000.W0062	With Head	Plain	M 6	20	10	3.2	6	3.0	4.0	5	6	6.1
34000.W0064	With Head	Plain	M 6	30	10	3.2	6	3.0	4.0	5	6	7.7
34000.W0066	With Head	Plain	M 6	40	10	3.2	6	16.0	4.0	5	6	10.0
34000.W0082	With Head	Plain	M 8	20	13	4.5	8	3.5	5.5	6	9	13.0
34000.W0084	With Head	Plain	M 8	35	13	4.5	8	3.5	5.5	6	9	17.0
34000.W0086	With Head	Plain	M 8	50	13	4.5	8	22.0	5.5	6	9	23.0
34000.W0102	With Head	Plain	M10	25	16	6.0	10	4.5	7.0	8	12	24.0
34000.W0104	With Head	Plain	M10	40	16	6.0	10	4.5	7.0	8	12	31.0
34000.W0106	With Head	Plain	M10	60	16	6.0	10	28.0	7.0	8	12	44.0
34000.W0122	With Head	Plain	M12	30	18	7.2	12	5.0	8.5	10	18	38.0
34000.W0124	With Head	Plain	M12	50	18	7.2	12	5.0	8.5	10	18	52.0
34000.W0126	With Head	Plain	M12	80	18	7.2	12	44.0	8.5	10	18	80.0
34000.W0162	With Head	Plain	M16	40	24	10.7	16	6.0	12.0	14	36	92.0
34000.W0164	With Head	Plain	M16	60	24	10.7	16	6.0	12.0	14	36	118.0
34000.W0166	With Head	Plain	M16	80	24	10.7	16	36.0	12.0	14	36	153.0
34000.W0172	With Head	Plain	M20	50	30	13.5	20	7.5	15.0	17	60	181.0
34000.W0174	With Head	Plain	M20	80	30	13.5	20	28.0	15.0	17	60	255.0
34000.W0176	With Head	Plain	M20	100	30	13.5	20	48.0	15.0	17	60	304.0
34000.W0182	With Head	Plain	M24	60	36	15.8	24	9.0	18.0	19	80	325.0
34000.W0184	With Head	Plain	M24	90	36	15.8	24	30.0	18.0	19	80	430.0
34000.W0186	With Head	Plain	M24	120	36	15.8	24	60.0	18.0	19	80	535.0
34000.W0192	With Head	Ribbed	M 8	20	13	4.5	8	3.5	5.5	6	9	13.0
34000.W0194	With Head	Ribbed	M 8	35	13	4.5	8	3.5	5.5	6	9	17.0
34000.W0196	With Head	Ribbed	M 8	50	13	4.5	8	22.0	5.5	6	9	23.0
34000.W0202	With Head	Ribbed	M10	25	16	6.0	10	4.5	7.0	8	12	24.0
34000.W0204	With Head	Ribbed	M10	40	16	6.0	10	4.5	7.0	8	12	31.0
34000.W0206	With Head	Ribbed	M10	60	16	6.0	10	28.0	7.0	8	12	44.0
34000.W0222	With Head	Ribbed	M12	30	18	7.2	12	5.0	8.5	10	18	38.0
34000.W0224	With Head	Ribbed	M12	50	18	7.2	12	5.0	8.5	10	18	52.0
34000.W0226	With Head	Ribbed	M12	80	18	7.2	12	44.0	8.5	10	18	80.0



Order No.	Type	Ball face	d ₁	l ₂	d ₂	d ₃	l ₃	l ₄	Ball dia.	A/F	Static load kN max.	Weight g
34000.W0262	With Head	Ribbed	M16	40	24	10.7	16	6.0	12.0	14	36	92.0
34000.W0264	With Head	Ribbed	M16	60	24	10.7	16	6.0	12.0	14	36	118.0
34000.W0266	With Head	Ribbed	M16	80	24	10.7	16	36.0	12.0	14	36	153.0
34000.W0272	With Head	Ribbed	M20	50	30	13.5	20	7.5	15.0	17	60	181.0
34000.W0274	With Head	Ribbed	M20	80	30	13.5	20	28.0	15.0	17	60	255.0
34000.W0276	With Head	Ribbed	M20	100	30	13.5	20	48.0	15.0	17	60	304.0
34000.W0282	With Head	Ribbed	M24	60	36	15.8	24	9.0	18.0	19	80	325.0
34000.W0284	With Head	Ribbed	M24	90	36	15.8	24	30.0	18.0	19	80	430.0
34000.W0286	With Head	Ribbed	M24	120	36	15.8	24	60.0	18.0	19	80	535.0
34000.W0563	W/o Head	Plain	M 6	12	-	3.2	-	-	4.0	3	6	1.6
34000.W0564	W/o Head	Plain	M 6	16	-	3.2	-	-	4.0	3	6	2.3
34000.W0565	W/o Head	Plain	M 6	20	-	3.2	-	-	4.0	3	6	2.9
34000.W0566	W/o Head	Plain	M 6	25	-	3.2	-	-	4.0	3	6	3.8
34000.W0583	W/o Head	Plain	M 8	16	-	4.5	-	-	5.5	4	9	3.7
34000.W0584	W/o Head	Plain	M 8	20	-	4.5	-	-	5.5	4	9	5.1
34000.W0585	W/o Head	Plain	M 8	25	-	4.5	-	-	5.5	4	9	6.5
34000.W0586	W/o Head	Plain	M 8	30	-	4.5	-	-	5.5	4	9	8.1
34000.W0603	W/o Head	Plain	M10	20	-	6.0	-	-	7.0	5	12	7.6
34000.W0604	W/o Head	Plain	M10	25	-	6.0	-	-	7.0	5	12	10.0
34000.W0606	W/o Head	Plain	M10	35	-	6.0	-	-	7.0	5	12	15.0
34000.W0608	W/o Head	Plain	M10	40	-	6.0	-	-	7.0	5	12	17.0
34000.W0622	W/o Head	Plain	M12	20	-	7.2	-	-	8.5	6	18	11.0
34000.W0624	W/o Head	Plain	M12	30	-	7.2	-	-	8.5	6	18	18.0
34000.W0626	W/o Head	Plain	M12	40	-	7.2	-	-	8.5	6	18	24.0
34000.W0628	W/o Head	Plain	M12	50	-	7.2	-	-	8.5	6	18	32.0
34000.W0661	W/o Head	Plain	M16	20	-	10.7	-	-	12.0	8	36	22.0
34000.W0662	W/o Head	Plain	M16	25	-	10.7	-	-	12.0	8	36	28.0
34000.W0664	W/o Head	Plain	M16	35	-	10.7	-	-	12.0	8	36	38.0
34000.W0666	W/o Head	Plain	M16	50	-	10.7	-	-	12.0	8	36	60.0
34000.W0672	W/o Head	Plain	M20	30	-	13.5	-	-	15.0	10	60	52.0
34000.W0674	W/o Head	Plain	M20	40	-	13.5	-	-	15.0	10	60	70.0
34000.W0675	W/o Head	Plain	M20	50	-	13.5	-	-	15.0	10	60	90.0
34000.W0676	W/o Head	Plain	M20	60	-	13.5	-	-	15.0	10	60	111.0
34000.W0682	W/o Head	Plain	M24	35	-	15.8	-	-	18.0	12	80	86.0
34000.W0684	W/o Head	Plain	M24	50	-	15.8	-	-	18.0	12	80	125.0
34000.W0686	W/o Head	Plain	M24	80	-	15.8	-	-	18.0	12	80	216.0
34000.W0693	W/o Head	Ribbed	M 8	16	-	4.5	-	-	5.5	4	9	3.7
34000.W0694	W/o Head	Ribbed	M 8	20	-	4.5	-	-	5.5	4	9	5.1
34000.W0695	W/o Head	Ribbed	M 8	25	-	4.5	-	-	5.5	4	9	6.5
34000.W0696	W/o Head	Ribbed	M 8	30	-	4.5	-	-	5.5	4	9	8.1
34000.W0703	W/o Head	Ribbed	M10	20	-	6.0	-	-	7.0	5	12	7.6
34000.W0704	W/o Head	Ribbed	M10	25	-	6.0	-	-	7.0	5	12	10.0
34000.W0706	W/o Head	Ribbed	M10	35	-	6.0	-	-	7.0	5	12	15.0
34000.W0708	W/o Head	Ribbed	M10	40	-	6.0	-	-	7.0	5	12	17.0
34000.W0722	W/o Head	Ribbed	M12	20	-	7.2	-	-	8.5	6	18	11.0
34000.W0724	W/o Head	Ribbed	M12	30	-	7.2	-	-	8.5	6	18	18.0
34000.W0726	W/o Head	Ribbed	M12	40	-	7.2	-	-	8.5	6	18	24.0
34000.W0728	W/o Head	Ribbed	M12	50	-	7.2	-	-	8.5	6	18	32.0
34000.W0761	W/o Head	Ribbed	M16	20	-	10.7	-	-	12.0	8	36	22.0
34000.W0762	W/o Head	Ribbed	M16	25	-	10.7	-	-	12.0	8	36	28.0
34000.W0764	W/o Head	Ribbed	M16	35	-	10.7	-	-	12.0	8	36	38.0
34000.W0766	W/o Head	Ribbed	M16	50	-	10.7	-	-	12.0	8	36	60.0
34000.W0772	W/o Head	Ribbed	M20	30	-	13.5	-	-	15.0	10	60	52.0
34000.W0774	W/o Head	Ribbed	M20	40	-	13.5	-	-	15.0	10	60	70.0
34000.W0775	W/o Head	Ribbed	M20	50	-	13.5	-	-	15.0	10	60	90.0
34000.W0776	W/o Head	Ribbed	M20	60	-	13.5	-	-	15.0	10	60	111.0
34000.W0782	W/o Head	Ribbed	M24	35	-	15.8	-	-	18.0	12	80	86.0
34000.W0784	W/o Head	Ribbed	M24	50	-	15.8	-	-	18.0	12	80	125.0



Thrust Screws - Steel

ball ended - flat - metal - secured



Thrust Screws

Order No.	Type	Ball face	d ₁	l ₂	d ₂	d ₃	l ₃	l ₄	Ball dia.	A/F	Static load kN max.	Weight g
34000.W0786	W/o Head	Ribbed	M24	80	-	15.8	-	-	18.0	12	80	216.0

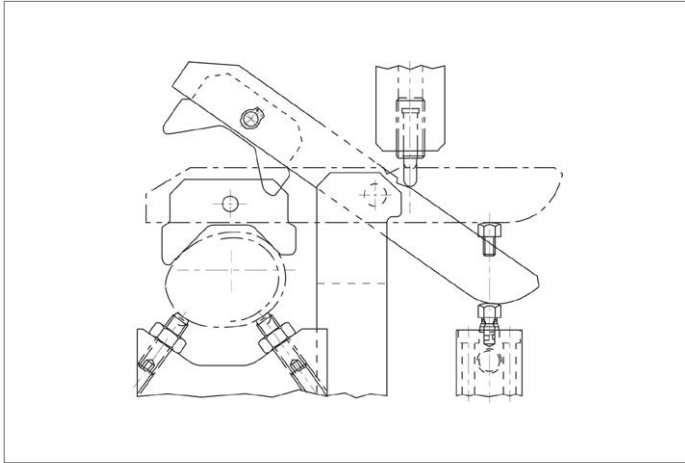

THRUST SCREWS



34002

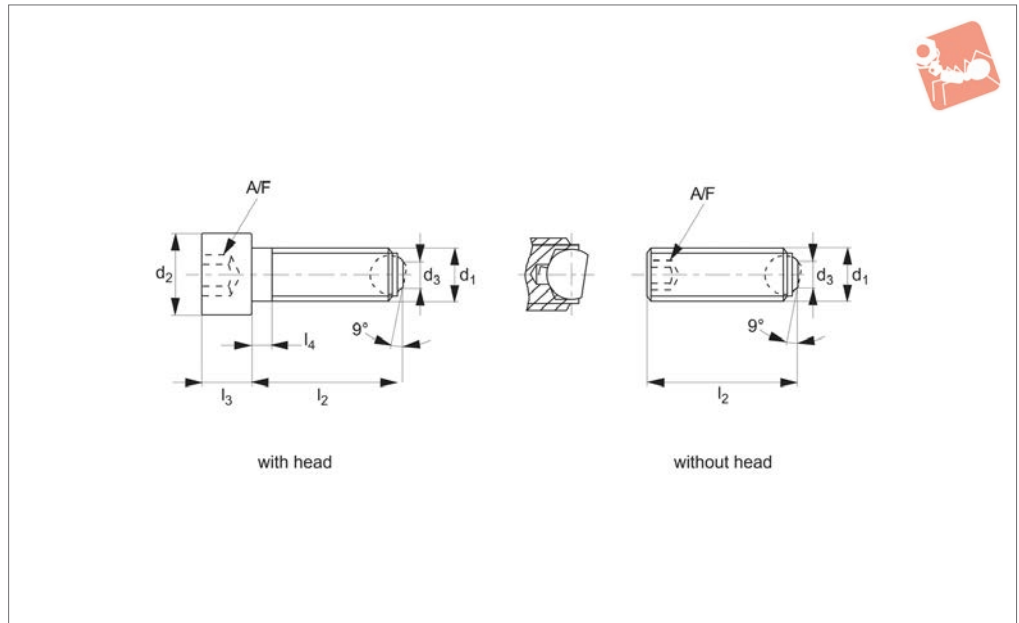

Material

Screw: stainless steel 1.4305 (AISI 303).
Heat-treated steel, 1200±100 N/mm².
Ball: stainless steel, hardened

surfaces that are not exactly parallel. Load transmission maximized due to moveable ball.
Note: thread runout l_4 .

face ball cannot flip over - see technical diagram

Technical Notes

For clamping, tightening or supporting of

Tips

Ball secured against rotation so the flat

Order No.	Type	d ₁	l ₂	d ₂	d ₃	l ₃	l ₄	Ball dia.	A/F	Weight g
34002.W0302	With Head	M 6	20	10	3.2	6	3.0	4.0	5	6.1
34002.W0304	With Head	M 6	30	10	3.2	6	3.0	4.0	5	7.7
34002.W0306	With Head	M 6	40	10	3.2	6	16.0	4.0	5	10.0
34002.W0312	With Head	M 8	20	13	4.5	8	3.5	5.5	6	13.0
34002.W0314	With Head	M 8	35	13	4.5	8	3.5	5.5	6	17.0
34002.W0316	With Head	M 8	50	13	4.5	8	22.0	5.5	6	23.0
34002.W0322	With Head	M10	25	16	6.0	10	4.5	7.0	8	24.0
34002.W0324	With Head	M10	40	16	6.0	10	4.5	7.0	8	31.0
34002.W0326	With Head	M10	60	16	6.0	10	28.0	7.0	8	44.0
34002.W0332	With Head	M12	30	18	7.2	12	5.0	8.5	10	48.0
34002.W0334	With Head	M12	50	18	7.2	12	5.0	8.5	10	52.0
34002.W0336	With Head	M12	80	18	7.2	12	44.0	8.5	10	80.0
34002.W0342	With Head	M16	40	24	10.7	16	6.0	12.0	14	92.0
34002.W0344	With Head	M16	60	24	10.7	16	6.0	12.0	14	118.0
34002.W0346	With Head	M16	80	24	10.7	16	36.0	12.0	14	153.0
34002.W0803	W/o Head	M 6	12	-	3.2	-	-	4.0	3	1.6
34002.W0804	W/o Head	M 6	16	-	3.2	-	-	4.0	3	2.3
34002.W0805	W/o Head	M 6	20	-	3.2	-	-	4.0	3	2.9
34002.W0806	W/o Head	M 6	25	-	3.2	-	-	4.0	3	3.8
34002.W0813	W/o Head	M 8	16	-	4.5	-	-	5.5	4	3.7
34002.W0814	W/o Head	M 8	20	-	4.5	-	-	5.5	4	5.1
34002.W0815	W/o Head	M 8	25	-	4.5	-	-	5.5	4	6.5
34002.W0816	W/o Head	M 8	30	-	4.5	-	-	5.5	4	8.1
34002.W0823	W/o Head	M10	20	-	6.0	-	-	7.0	5	7.6
34002.W0824	W/o Head	M10	25	-	6.0	-	-	7.0	5	10.0
34002.W0826	W/o Head	M10	35	-	6.0	-	-	7.0	5	15.0
34002.W0828	W/o Head	M10	40	-	6.0	-	-	7.0	5	17.0
34002.W0832	W/o Head	M12	20	-	7.2	-	-	8.5	6	11.0
34002.W0834	W/o Head	M12	30	-	7.2	-	-	8.5	6	18.0
34002.W0836	W/o Head	M12	40	-	7.2	-	-	8.5	6	24.0
34002.W0838	W/o Head	M12	50	-	7.2	-	-	8.5	6	32.0



Thrust Screws - Stainless

ball ended - flat - metal - secured



Thrust Screws

Order No.	Type	d ₁	l ₂	d ₂	d ₃	l ₃	l ₄	Ball dia.	A/F	Weight g
34002.W0841	W/o Head	M16	20	-	10.7	-	-	12.0	8	22.0
34002.W0842	W/o Head	M16	25	-	10.7	-	-	12.0	8	29.0
34002.W0844	W/o Head	M16	35	-	10.7	-	-	12.0	8	38.0
34002.W0846	W/o Head	M16	50	-	10.7	-	-	12.0	8	60.0

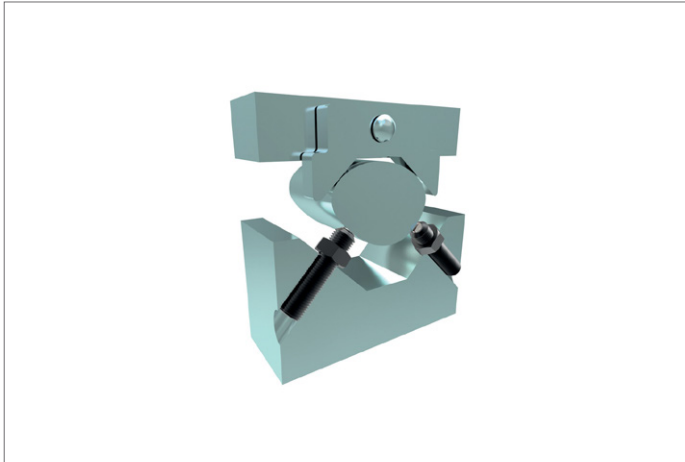



34140.1

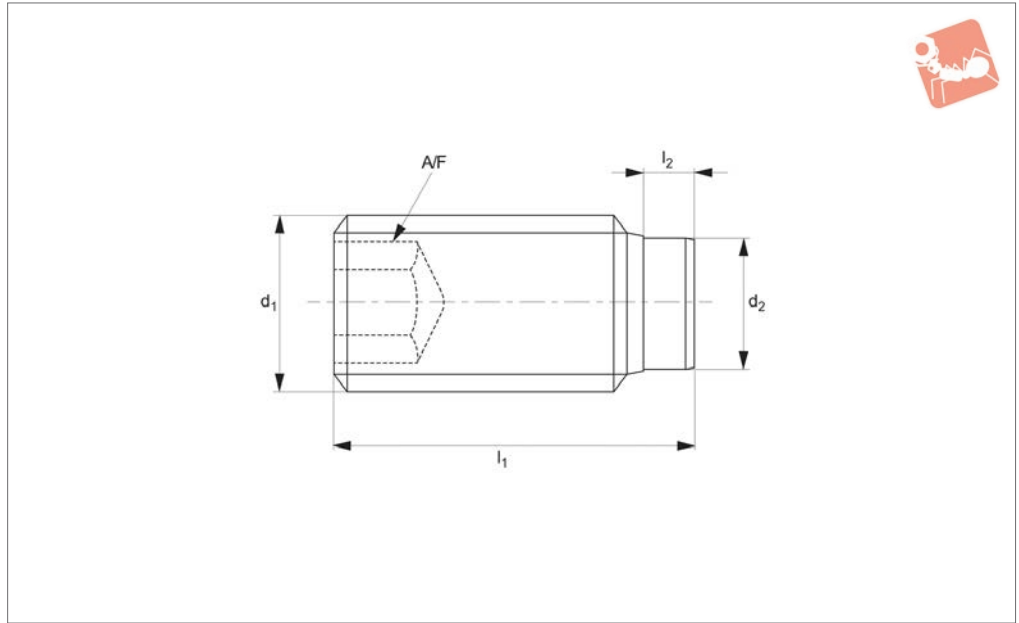

THRUST SCREWS

Material

Screw: heat treated steel, 1200 +/-100 N/mm².
Pad: brass.

Technical Notes

Brass pad pressed in. These thrust screws can be used for gentle clamping or pressing of threaded spindles, axles, shafts or

surface treated parts.

Order No.	Material	Type	d ₁	l ₁	l ₂	d ₂	A/F	Weight g
34140.W0034	Steel	Brass Pad	M 3	7.5	1.0	1.5	1.5	0.3
34140.W0036	Steel	Brass Pad	M 3	10.0	1.0	1.5	1.5	0.5
34140.W0042	Steel	Brass Pad	M 4	6.5	1.2	2.5	2.0	0.3
34140.W0044	Steel	Brass Pad	M 4	10.5	1.2	2.5	2.0	0.8
34140.W0046	Steel	Brass Pad	M 4	16.5	1.2	2.5	2.0	1.2
34140.W0052	Steel	Brass Pad	M 5	8.5	1.3	3.0	2.5	0.9
34140.W0054	Steel	Brass Pad	M 5	12.5	1.3	3.0	2.5	1.4
34140.W0056	Steel	Brass Pad	M 5	20.5	1.3	3.0	2.5	2.1
34140.W0062	Steel	Brass Pad	M 6	11.5	1.9	4.0	3.0	1.7
34140.W0064	Steel	Brass Pad	M 6	17.5	1.9	4.0	3.0	2.7
34140.W0066	Steel	Brass Pad	M 6	26.5	1.9	4.0	3.0	4.2
34140.W0080	Steel	Brass Pad	M 8	8.0	1.4	5.5	4.0	2.2
34140.W0082	Steel	Brass Pad	M 8	12.0	2.5	5.5	4.0	3.0
34140.W0086	Steel	Brass Pad	M 8	22.0	2.5	5.5	4.0	5.8
34140.W0088	Steel	Brass Pad	M 8	32.0	2.5	5.5	4.0	8.9
34140.W0102	Steel	Brass Pad	M10	14.0	2.7	7.0	5.0	5.6
34140.W0104	Steel	Brass Pad	M10	18.0	2.7	7.0	5.0	6.7
34140.W0106	Steel	Brass Pad	M10	27.0	2.7	7.0	5.0	11.0
34140.W0108	Steel	Brass Pad	M10	37.0	2.7	7.0	5.0	16.0
34140.W0122	Steel	Brass Pad	M12	18.5	3.4	8.5	6.0	10.0
34140.W0124	Steel	Brass Pad	M12	22.5	3.4	8.5	6.0	12.0
34140.W0126	Steel	Brass Pad	M12	32.5	3.4	8.5	6.0	20.0
34140.W0128	Steel	Brass Pad	M12	42.5	3.4	8.5	6.0	29.0



Thrust Screws - Brass Pad steel



Thrust Screws

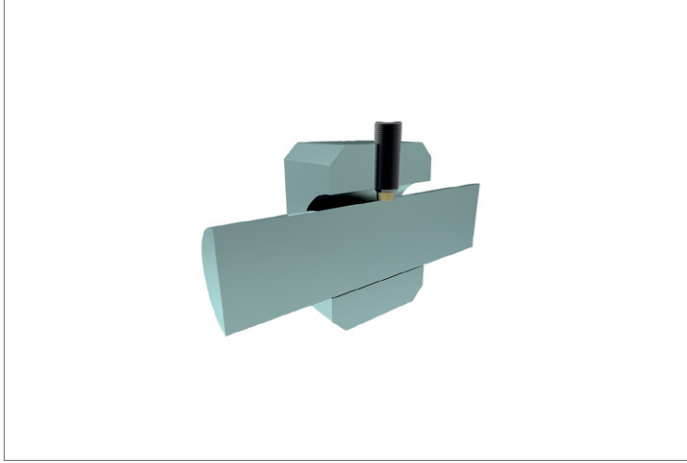

THRUST SCREWS



34140.2

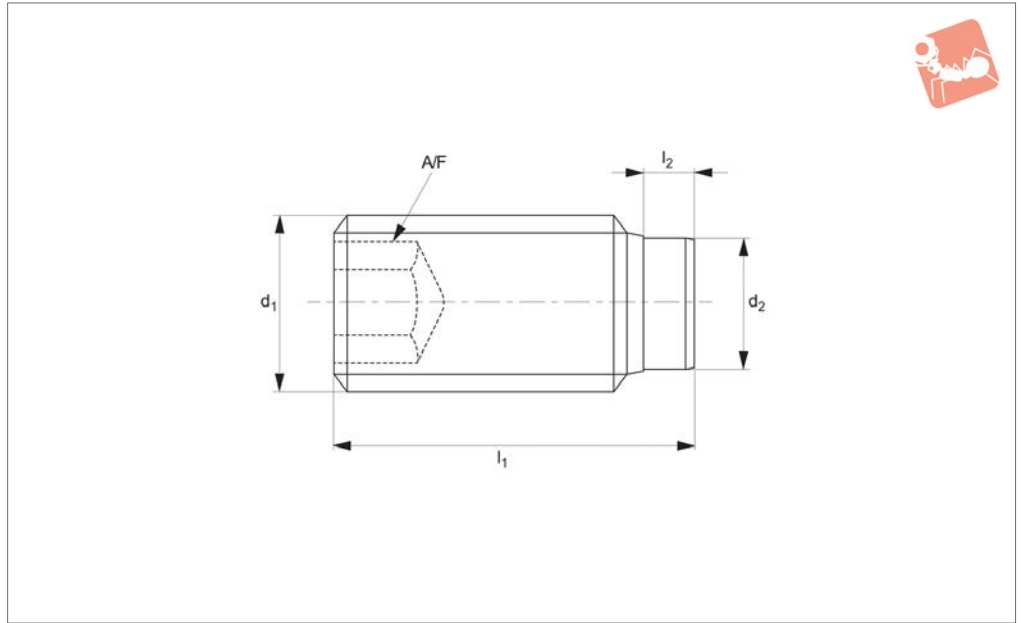

THRUST SCREWS

Material

Screw: stainless steel 1.4305 (AISI 303).
Pad: brass.

Technical Notes

Brass pad pressed in. These thrust screws can be used for gentle clamping or pres-

sing of threaded spindles, axles, shafts or surface treated parts.

Order No.	Material	Type	d ₁	l ₁	l ₂	d ₂	A/F	Weight g
34140.W0432	Stainless	Brass Pad	M 3	5.0	1.0	1.5	1.5	0.2
34140.W0434	Stainless	Brass Pad	M 3	7.5	1.0	1.5	1.5	0.3
34140.W0436	Stainless	Brass Pad	M 3	10.0	1.0	1.5	1.5	0.5
34140.W0442	Stainless	Brass Pad	M 4	6.5	1.2	2.5	2.0	0.3
34140.W0444	Stainless	Brass Pad	M 4	10.5	1.2	2.5	2.0	0.8
34140.W0446	Stainless	Brass Pad	M 4	16.5	1.2	2.5	2.0	1.2
34140.W0452	Stainless	Brass Pad	M 5	8.5	1.3	3.0	2.5	0.9
34140.W0454	Stainless	Brass Pad	M 5	12.5	1.3	3.0	2.5	1.4
34140.W0456	Stainless	Brass Pad	M 5	20.5	1.3	3.0	2.5	2.1
34140.W0462	Stainless	Brass Pad	M 6	11.5	1.9	4.0	3.0	1.7
34140.W0464	Stainless	Brass Pad	M 6	17.5	1.9	4.0	3.0	2.7
34140.W0466	Stainless	Brass Pad	M 6	26.5	1.9	4.0	3.0	4.2
34140.W0482	Stainless	Brass Pad	M 8	12.0	2.5	5.5	4.0	3.0
34140.W0486	Stainless	Brass Pad	M 8	22.0	2.5	5.5	4.0	5.8
34140.W0488	Stainless	Brass Pad	M 8	32.0	2.5	5.5	4.0	8.9
34140.W0502	Stainless	Brass Pad	M10	14.0	2.7	7.0	5.0	5.6
34140.W0504	Stainless	Brass Pad	M10	18.0	2.7	7.0	5.0	6.7
34140.W0506	Stainless	Brass Pad	M10	27.0	2.7	7.0	5.0	11.0
34140.W0508	Stainless	Brass Pad	M10	37.0	2.7	7.0	5.0	16.0
34140.W0522	Stainless	Brass Pad	M12	18.5	3.4	8.5	6.0	10.0
34140.W0524	Stainless	Brass Pad	M12	22.5	3.4	8.5	6.0	12.0
34140.W0526	Stainless	Brass Pad	M12	32.5	3.4	8.5	6.0	20.0
34140.W0528	Stainless	Brass Pad	M12	42.5	3.4	8.5	6.0	29.0

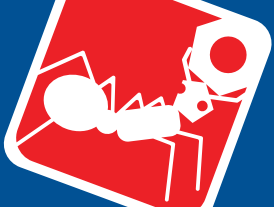

Thrust Screws - Brass Pad stainless steel



Thrust Screws

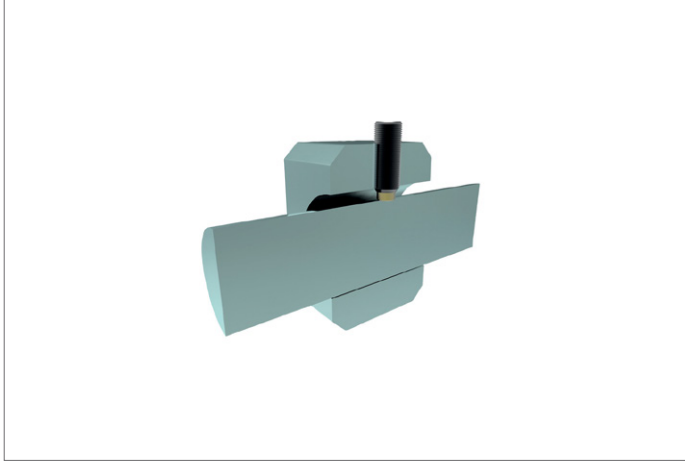

THRUST SCREWS



34160.1

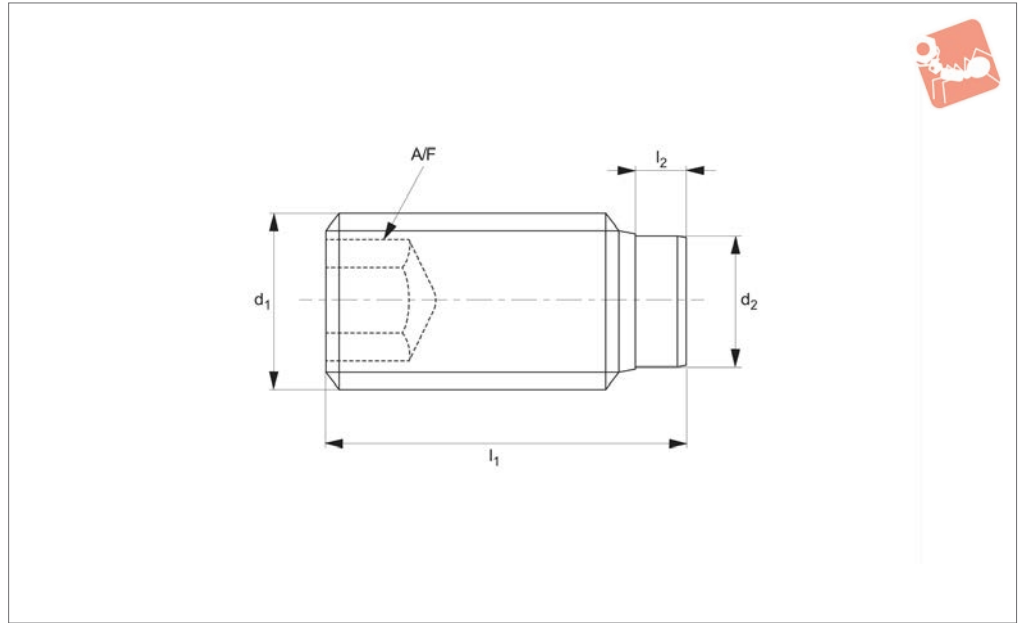

Material

Screw: heat treated steel, 1200 +/-100 N/mm².
Pad: thermoplastic POM, white.

Technical Notes

Thermoplastic bolt pressed in.
For gentle clamping or pressing of thread spindles, axles, shafts and surface treated

parts.

Order No.	Material	Type	d ₁	l ₁	l ₂	d ₂	A/F	Weight g
34160.W0242	Steel	Thermo Pad	M 4	7.0	1.0	2.0	2.0	0.3
34160.W0243	Steel	Thermo Pad	M 4	9.0	1.0	2.0	2.0	0.4
34160.W0244	Steel	Thermo Pad	M 4	11.0	1.0	2.0	2.0	0.6
34160.W0245	Steel	Thermo Pad	M 4	13.0	1.0	2.0	2.0	0.7
34160.W0246	Steel	Thermo Pad	M 4	17.0	1.0	2.0	2.0	1.0
34160.W0247	Steel	Thermo Pad	M 4	21.0	1.0	2.0	2.0	1.3
34160.W0252	Steel	Thermo Pad	M 5	9.0	1.0	3.0	2.5	0.7
34160.W0253	Steel	Thermo Pad	M 5	11.0	1.0	3.0	2.5	0.8
34160.W0254	Steel	Thermo Pad	M 5	13.0	1.0	3.0	2.5	1.0
34160.W0255	Steel	Thermo Pad	M 5	17.0	1.0	3.0	2.5	1.2
34160.W0256	Steel	Thermo Pad	M 5	21.0	1.0	3.0	2.5	2.0
34160.W0257	Steel	Thermo Pad	M 5	26.0	1.0	3.0	2.5	2.6
34160.W0262	Steel	Thermo Pad	M 6	11.3	1.3	3.5	3.0	1.2
34160.W0263	Steel	Thermo Pad	M 6	13.3	1.3	3.5	3.0	1.5
34160.W0264	Steel	Thermo Pad	M 6	17.3	1.3	3.5	3.0	2.2
34160.W0265	Steel	Thermo Pad	M 6	21.3	1.3	3.5	3.0	2.8
34160.W0266	Steel	Thermo Pad	M 6	26.3	1.3	3.5	3.0	3.8
34160.W0267	Steel	Thermo Pad	M 6	33.3	1.3	3.5	3.0	4.9
34160.W0268	Steel	Thermo Pad	M 6	41.3	1.3	3.5	3.0	6.3
34160.W0270	Steel	Thermo Pad	M 6	51.3	1.3	3.5	3.0	7.9
34160.W0282	Steel	Thermo Pad	M 8	13.6	1.6	5.0	4.0	2.6
34160.W0283	Steel	Thermo Pad	M 8	17.6	1.6	5.0	4.0	3.6
34160.W0284	Steel	Thermo Pad	M 8	21.6	1.6	5.0	4.0	5.0
34160.W0285	Steel	Thermo Pad	M 8	26.6	1.6	5.0	4.0	6.4
34160.W0286	Steel	Thermo Pad	M 8	33.6	1.6	5.0	4.0	8.5
34160.W0287	Steel	Thermo Pad	M 8	41.6	1.6	5.0	4.0	11.0
34160.W0288	Steel	Thermo Pad	M 8	51.6	1.6	5.0	4.0	14.0
34160.W0290	Steel	Thermo Pad	M 8	64.6	1.6	5.0	4.0	18.0
34160.W0302	Steel	Thermo Pad	M10	17.9	1.9	6.5	5.0	5.2
34160.W0303	Steel	Thermo Pad	M10	21.9	1.9	6.5	5.0	7.1
34160.W0304	Steel	Thermo Pad	M10	26.9	1.9	6.5	5.0	9.9
34160.W0305	Steel	Thermo Pad	M10	33.9	1.9	6.5	5.0	13.0
34160.W0306	Steel	Thermo Pad	M10	41.9	1.9	6.5	5.0	17.0
34160.W0307	Steel	Thermo Pad	M10	51.9	1.9	6.5	5.0	22.0



Thrust Screws - Plastic Pad steel



Thrust Screws

Order No.	Material	Type	d ₁	l ₁	l ₂	d ₂	A/F	Weight g
34160.W0308	Steel	Thermo Pad	M10	64.9	1.9	6.5	5.0	28.0
34160.W0310	Steel	Thermo Pad	M10	81.9	1.9	6.5	5.0	36.0
34160.W0322	Steel	Thermo Pad	M12	22.1	2.1	8.0	6.0	9.0
34160.W0323	Steel	Thermo Pad	M12	27.1	2.1	8.0	6.0	10.0
34160.W0324	Steel	Thermo Pad	M12	34.1	2.1	8.0	6.0	19.0
34160.W0325	Steel	Thermo Pad	M12	42.1	2.1	8.0	6.0	24.0
34160.W0326	Steel	Thermo Pad	M12	52.1	2.1	8.0	6.0	31.0
34160.W0327	Steel	Thermo Pad	M12	65.1	2.1	8.0	6.0	40.0
34160.W0330	Steel	Thermo Pad	M12	82.1	2.1	8.0	6.0	51.0
34160.W0332	Steel	Thermo Pad	M12	102.1	2.1	8.0	6.0	66.0

THRUST SCREWS



34160.2

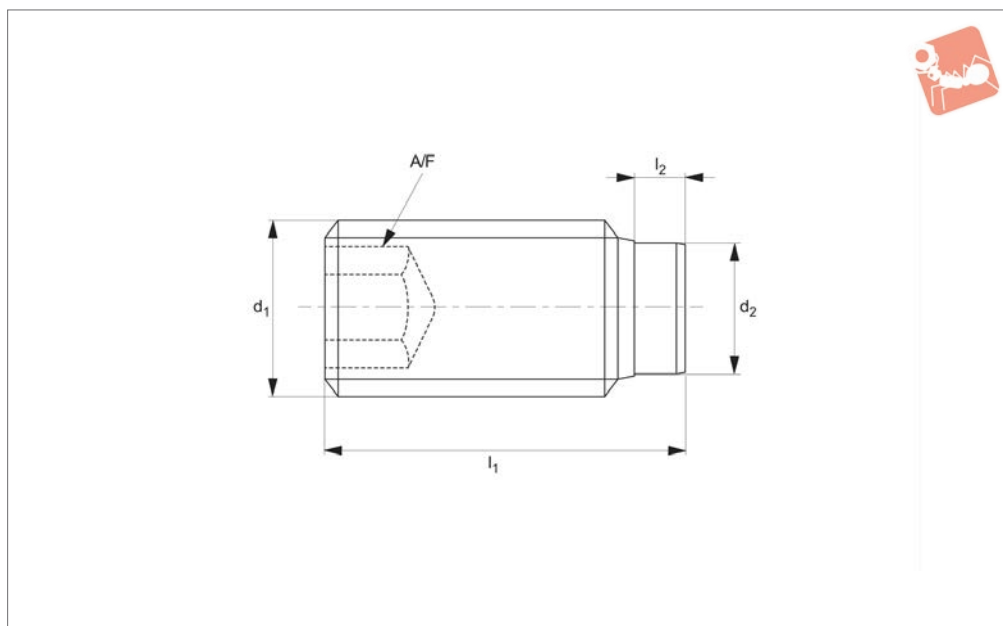

Material

Screw: stainless steel 1.4305 (AISI 303).
Pad: thermoplastic POM, white.

Technical Notes

Thermoplastic bolt pressed in.
For gentle clamping or pressing of thread

spindles, axles, shafts and surface treated parts.

Order No.	Material	Type	d ₁	l ₁	l ₂	d ₂	A/F	Weight g
34160.W0632	Stainless	Thermo Pad	M 3	3.8	0.8	1.5	1.5	0.2
34160.W0634	Stainless	Thermo Pad	M 3	5.8	0.8	1.5	1.5	0.3
34160.W0636	Stainless	Thermo Pad	M 3	8.8	0.8	1.5	1.5	0.4
34160.W0638	Stainless	Thermo Pad	M 3	10.8	0.8	1.5	1.5	0.5
34160.W0642	Stainless	Thermo Pad	M 4	7.0	1.0	2.0	2.0	0.3
34160.W0643	Stainless	Thermo Pad	M 4	9.0	1.0	2.0	2.0	0.4
34160.W0644	Stainless	Thermo Pad	M 4	11.0	1.0	2.0	2.0	0.6
34160.W0645	Stainless	Thermo Pad	M 4	13.0	1.0	2.0	2.0	0.7
34160.W0646	Stainless	Thermo Pad	M 4	17.0	1.0	2.0	2.0	1.0
34160.W0652	Stainless	Thermo Pad	M 5	9.0	1.0	3.0	2.5	0.7
34160.W0653	Stainless	Thermo Pad	M 5	11.0	1.0	3.0	2.5	0.8
34160.W0654	Stainless	Thermo Pad	M 5	13.0	1.0	3.0	2.5	1.0
34160.W0655	Stainless	Thermo Pad	M 5	17.0	1.0	3.0	2.5	1.2
34160.W0656	Stainless	Thermo Pad	M 5	21.0	1.0	3.0	2.5	2.0
34160.W0662	Stainless	Thermo Pad	M 6	11.3	1.3	3.5	3.0	1.2
34160.W0663	Stainless	Thermo Pad	M 6	13.3	1.3	3.5	3.0	1.5
34160.W0664	Stainless	Thermo Pad	M 6	17.3	1.3	3.5	3.0	2.2
34160.W0665	Stainless	Thermo Pad	M 6	21.3	1.3	3.5	3.0	2.8
34160.W0666	Stainless	Thermo Pad	M 6	26.3	1.3	3.5	3.0	3.8
34160.W0667	Stainless	Thermo Pad	M 6	33.3	1.3	3.5	3.0	4.9
34160.W0682	Stainless	Thermo Pad	M 8	13.6	1.6	5.0	4.0	2.6
34160.W0683	Stainless	Thermo Pad	M 8	17.6	1.6	5.0	4.0	3.6
34160.W0684	Stainless	Thermo Pad	M 8	21.6	1.6	5.0	4.0	5.0
34160.W0685	Stainless	Thermo Pad	M 8	26.6	1.6	5.0	4.0	6.4
34160.W0686	Stainless	Thermo Pad	M 8	33.6	1.6	5.0	4.0	8.5
34160.W0687	Stainless	Thermo Pad	M 8	41.6	1.6	5.0	4.0	11.0
34160.W0702	Stainless	Thermo Pad	M10	17.9	1.9	6.5	5.0	5.2
34160.W0703	Stainless	Thermo Pad	M10	21.9	1.9	6.5	5.0	7.1
34160.W0704	Stainless	Thermo Pad	M10	26.9	1.9	6.5	5.0	9.9
34160.W0705	Stainless	Thermo Pad	M10	33.9	1.9	6.5	5.0	13.0
34160.W0706	Stainless	Thermo Pad	M10	41.9	1.9	6.5	5.0	17.0
34160.W0707	Stainless	Thermo Pad	M10	51.9	1.9	6.5	5.0	22.0
34160.W0722	Stainless	Thermo Pad	M12	22.1	2.1	8.0	6.0	9.0
34160.W0723	Stainless	Thermo Pad	M12	27.1	2.1	8.0	6.0	10.0



Thrust Screws - Plastic Pad

stainless steel



Thrust Screws

Order No.	Material	Type	d ₁	l ₁	l ₂	d ₂	A/F	Weight g
34160.W0724	Stainless	Thermo Pad	M12	34.1	2.1	8.0	6.0	19.0
34160.W0725	Stainless	Thermo Pad	M12	42.1	2.1	8.0	6.0	24.0
34160.W0726	Stainless	Thermo Pad	M12	52.1	2.1	8.0	6.0	31.0
34160.W0727	Stainless	Thermo Pad	M12	65.1	2.1	8.0	6.0	40.0

THRUST SCREWS



34300

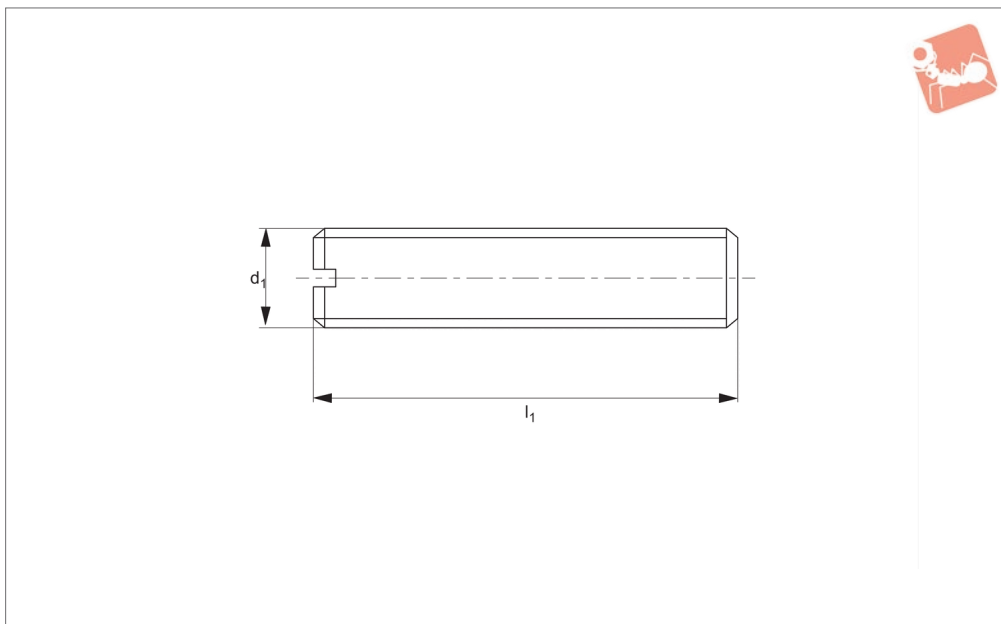

Material

Body: steel to tensile strength 500 N/mm²,
blackened.

Order No.	d ₁	l ₁
34300.W0060	M 6	20
34300.W0063	M 6	35
34300.W0064	M 6	40
34300.W0065	M 6	45
34300.W0066	M 6	50
34300.W0088	M 8	70
34300.W0089	M 8	80
34300.W0100	M10	25
34300.W0105	M10	50
34300.W0106	M10	55
34300.W0109	M10	80
34300.W0120	M12	30
34300.W0122	M12	40
34300.W0123	M12	45
34300.W0124	M12	50
34300.W0125	M12	55
34300.W0126	M12	60
34300.W0128	M12	80
34300.W0129	M12	100
34300.W0160	M16	30
34300.W0164	M16	50
34300.W0167	M16	70

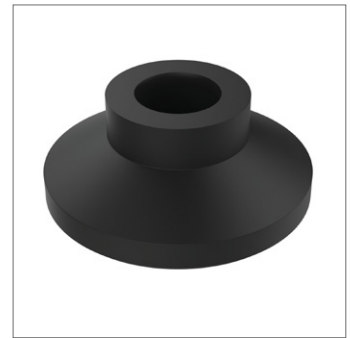
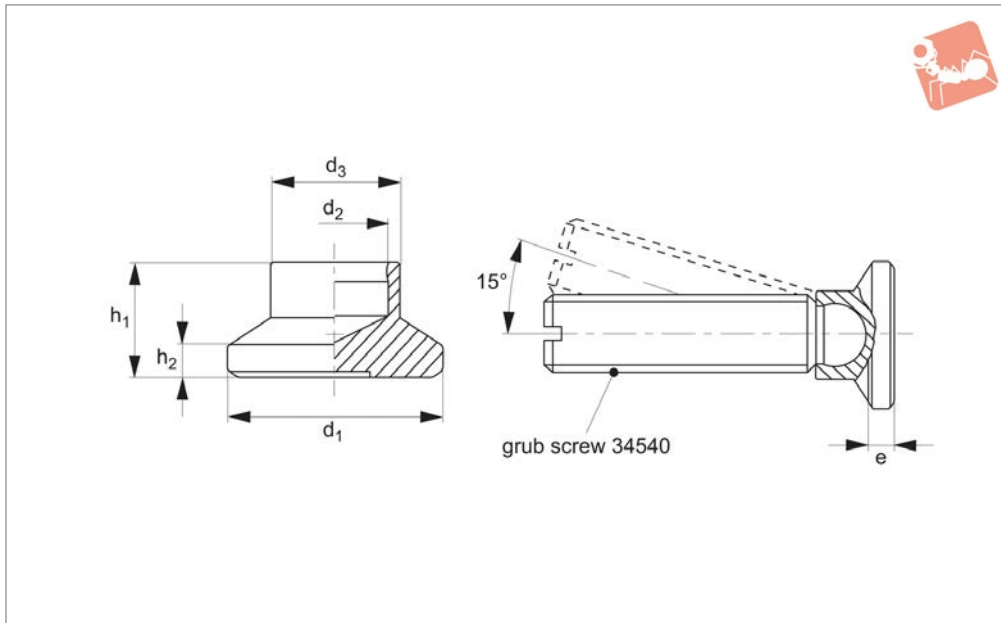

34530

THRUST SCREWS

Material

Thermoplastic (POM) black, matte.

Technical Notes

Can be used with grub screw no. 34540<X\ 34540#26>.

Order No.	d ₁	d ₂	d ₃	e ≈	h ₁	h ₂	Load capacity for static load kN max.	For grub screws 34540	Weight g
34530.W0014	15	4.5	8.6	3.6	7.6	2.5	3.5	M 6	1.0
34530.W0015	15	6.1	8.6	2.5	7.6	2.5	3.5	M 8	1.0
34530.W0017	18	6.1	10.8	4.2	9.2	2.5	3.5	M 8	1.8
34530.W0018	18	7.8	10.8	3.4	9.2	2.5	3.5	M10	2.0
34530.W0019	21	6.1	12.8	5.0	10.0	3.0	3.5	M 8	3.0
34530.W0020	21	7.8	12.8	4.3	10.0	3.0	3.5	M10	2.6
34530.W0021	21	9.4	12.8	3.4	10.0	3.0	3.5	M12	3.0
34530.W0023	25	6.1	13.0	5.5	10.5	3.0	3.5	M 8	4.0
34530.W0024	25	7.8	13.0	4.6	10.5	3.0	3.5	M10	3.6
34530.W0025	25	9.4	13.0	3.6	10.5	3.0	3.5	M12	3.4
34530.W0032	32	6.1	14.0	6.0	11.0	3.0	3.5	M 8	5.0
34530.W0033	32	7.8	14.0	5.0	11.0	3.0	3.5	M10	5.0
34530.W0034	32	9.4	14.0	4.2	11.0	3.0	3.5	M12	5.0
34530.W0040	40	6.1	16.0	8.0	13.0	4.0	3.5	M 8	11.0
34530.W0041	40	7.8	16.0	7.0	13.0	4.0	3.5	M10	10.0
34530.W0042	40	9.4	16.0	6.2	13.0	4.0	3.5	M12	10.0



THRUST SCREWS

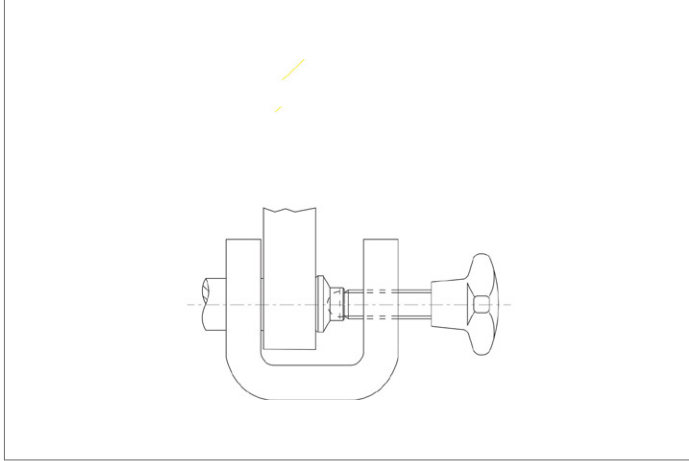

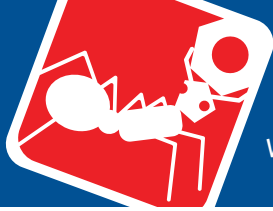

Grub Screws

with slot or hex end, and thrust point - form S - DIN



Thrust Screws

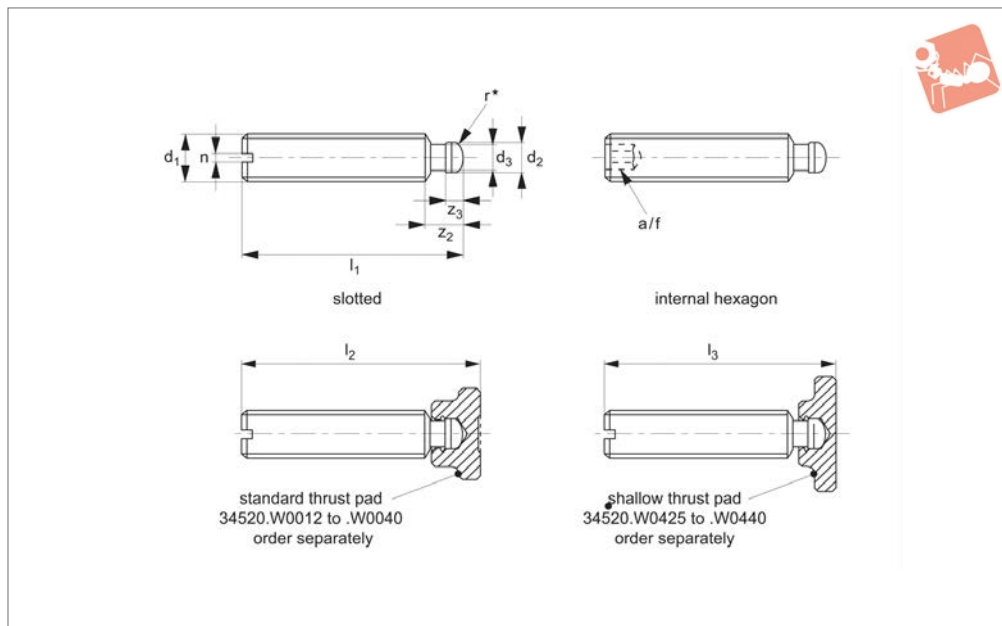

34500

THRUST SCREWS

Material

Body: steel to quality 5.8, thrust point hardened, blackened.

pads no. 34520<X\34520#26> standard or shallow type.

To ease assembly, DIN specification has been amended by addition of radius r^* .

Technical Notes

The grub screws can be used with thrust

Order No.	Type	d_1	d_2 tol. h11	d_3	l_1	l_2 ≈	l_3 ≈	n	z_2	z_3	A/F	Weight g
34500.W0061	Slotted	M 6	4.5	4.0	30	32.1	-	1.0	6.0	2.5	-	4.5
34500.W0062	Slotted	M 6	4.5	4.0	50	52.1	-	1.0	6.0	2.5	-	7.8
34500.W0081	Slotted	M 8	6.0	5.4	40	43.0	42.5	1.2	7.5	3.0	-	11.0
34500.W0082	Slotted	M 8	6.0	5.4	60	63.0	62.5	1.2	7.5	3.0	-	17.0
34500.W0101	Slotted	M10	8.0	7.2	60	63.6	62.6	1.6	9.0	4.5	-	27.0
34500.W0102	Slotted	M10	8.0	7.2	80	83.6	82.6	1.6	9.0	4.5	-	37.0
34500.W0121	Slotted	M12	8.0	7.2	60	64.6	62.6	2.0	10.0	4.5	-	38.0
34500.W0122	Slotted	M12	8.0	7.2	80	84.6	82.6	2.0	10.0	4.5	-	51.0
34500.W0123	Slotted	M12	8.0	7.2	100	104.6	102.6	2.0	10.0	4.5	-	65.0
34500.W0161	Slotted	M16	12.0	11.0	80	85.4	82.9	2.5	12.0	5.0	-	100.0
34500.W0162	Slotted	M16	12.0	11.0	100	105.4	102.9	2.5	12.0	5.0	-	126.0
34500.W0163	Slotted	M16	12.0	11.0	125	130.4	127.9	2.5	12.0	5.0	-	160.0
34500.W0201	Slotted	M20	15.5	14.4	100	105.5	-	3.0	14.0	5.5	-	190.0
34500.W0202	Slotted	M20	15.5	14.4	125	130.5	-	3.0	14.0	5.5	-	240.0
34500.W0203	Slotted	M20	15.5	14.4	150	155.5	-	3.0	14.0	5.5	-	290.0
34500.W0361	Internal Hexagon	M 6	4.5	4.0	30	32.1	-	-	6.0	2.5	3	4.3
34500.W0362	Internal Hexagon	M 6	4.5	4.0	50	52.1	-	-	6.0	2.5	3	7.6
34500.W0381	Internal Hexagon	M 8	6.0	5.4	40	43.0	42.5	-	7.5	3.0	4	11.0
34500.W0382	Internal Hexagon	M 8	6.0	5.4	60	63.0	62.5	-	7.5	3.0	4	17.0
34500.W0401	Internal Hexagon	M10	8.0	7.2	60	63.6	62.6	-	9.0	4.5	5	26.0
34500.W0402	Internal Hexagon	M10	8.0	7.2	80	83.6	82.6	-	9.0	4.5	5	36.0
34500.W0421	Internal Hexagon	M12	8.0	7.2	60	64.6	62.6	-	10.0	4.5	6	36.0
34500.W0422	Internal Hexagon	M12	8.0	7.2	80	84.6	82.6	-	10.0	4.5	6	57.0
34500.W0423	Internal Hexagon	M12	8.0	7.2	100	104.6	102.6	-	10.0	4.5	6	64.0
34500.W0461	Internal Hexagon	M16	12.0	11.0	80	85.4	82.9	-	12.0	5.0	8	91.0
34500.W0462	Internal Hexagon	M16	12.0	11.0	100	105.4	102.9	-	12.0	5.0	8	118.0
34500.W0463	Internal Hexagon	M16	12.0	11.0	125	130.4	127.9	-	12.0	5.0	8	150.0
34500.W0501	Internal Hexagon	M20	15.5	14.4	100	105.5	-	-	14.0	5.5	10	182.0
34500.W0502	Internal Hexagon	M20	15.5	14.4	125	130.5	-	-	14.0	5.5	10	233.0
34500.W0503	Internal Hexagon	M20	15.5	14.4	150	155.5	-	-	14.0	5.5	10	284.0

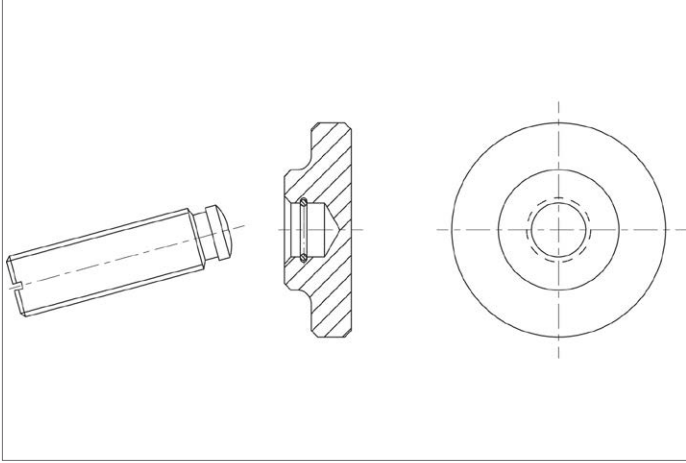

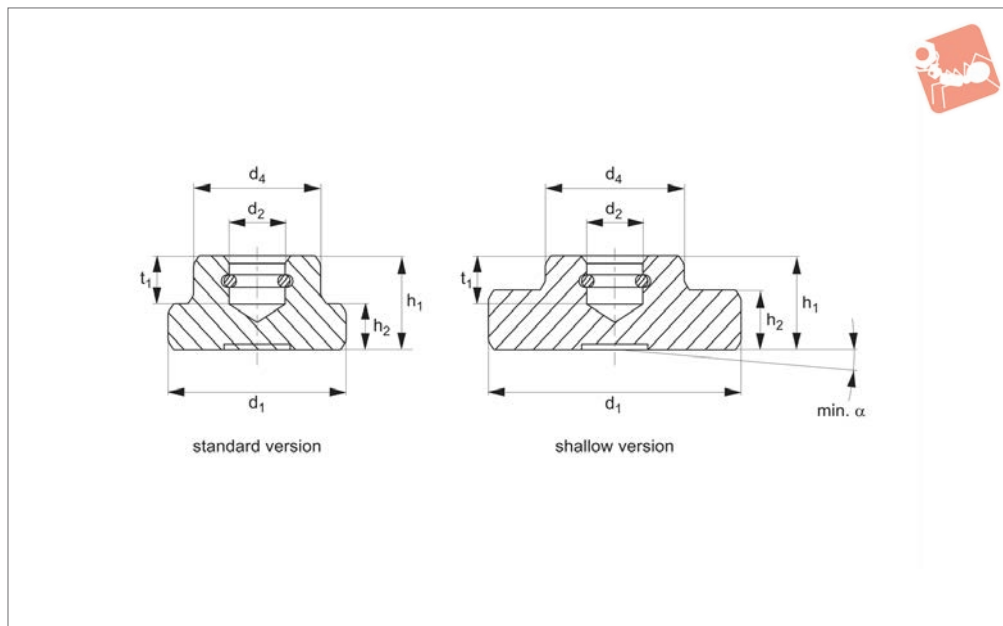

34520

THRUST SCREWS

Material

Case-hardened steel, spring retainer inserted.

Technical Notes

For use with grub screws part no. 34500<X\34500#26>.

Order No.	Type	d ₁	d ₂ tol. H12	d ₄	h ₁	h ₂	t ₁	α °	For grub screws 34500	Weight g
34520.W0012	Standard	12	4.6	10	7	2.5	4.0	7	M 6	4.3
34520.W0016	Standard	16	6.1	12	9	4.0	5.0	4	M 8	9.4
34520.W0020	Standard	20	8.1	15	11	5.0	6.0	3	M10	18.0
34520.W0025	Standard	25	8.1	18	13	6.0	7.0	3	M12	30.0
34520.W0032	Standard	32	12.1	22	15	7.0	7.5	5	M16	59.0
34520.W0040	Standard	40	15.6	28	16	9.0	8.0	4	M20	106.0
34520.W0425	Shallow	25	6.1	12	8	4.0	4.5	4	M 8	18.0
34520.W0432	Shallow	32	8.1	18	10	6.0	6.0	3	M10/M12	43.0
34520.W0440	Shallow	40	12.1	22	12	7.0	7.0	5	M16	75.0

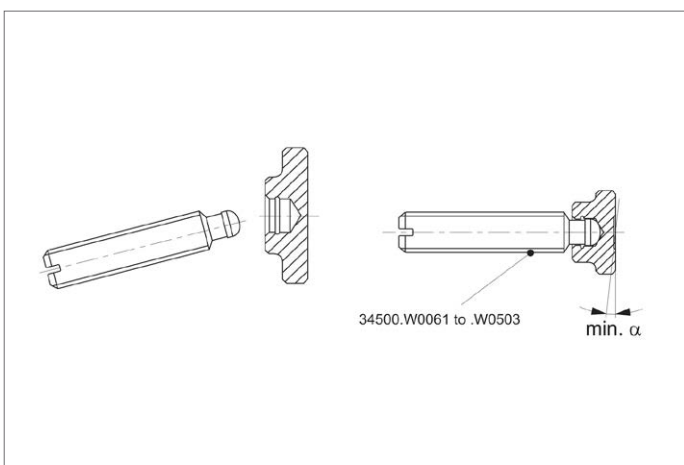



34540

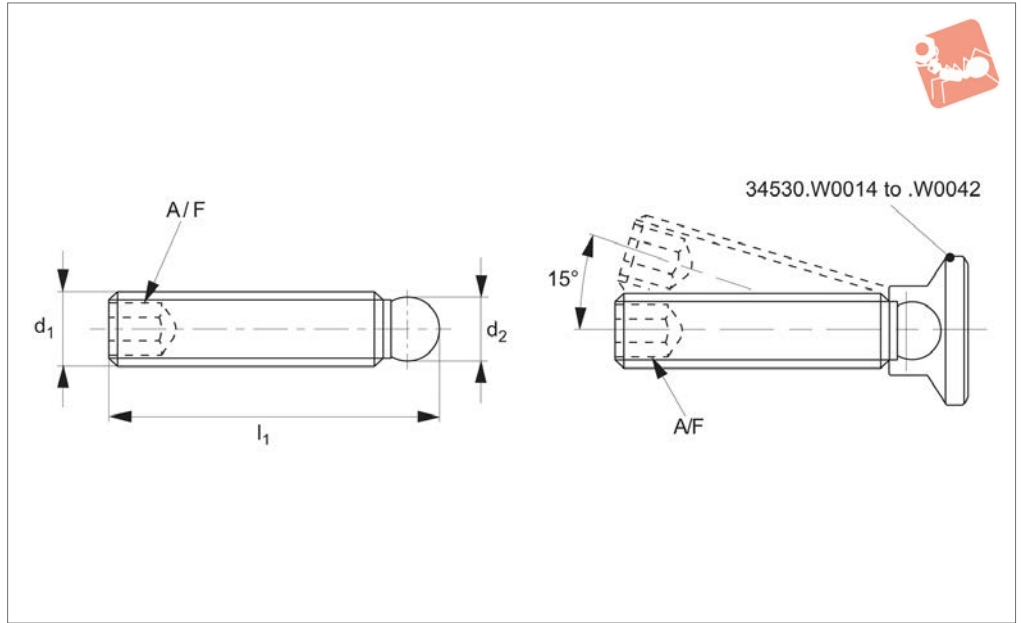

Material

stainless steel 1.4305 (AISI 303).

34530#26>.

Steel type:

free cutting steel, quality 5.8, blackened.

Technical Notes

Can be used with thrust pads no. 34530<X\

Stainless steel type:

Order No.	Material	d ₁	d ₂ +0.05	l ₁	A/F	Weight g
34540.W0210	Steel	M 6	4.47	30	3	5.1
34540.W0214	Steel	M 6	4.47	40	3	5.9
34540.W0218	Steel	M 6	4.47	50	3	7.6
34540.W0219	Steel	M 8	6.10	25	4	5.8
34540.W0220	Steel	M 8	6.10	40	4	11.0
34540.W0224	Steel	M 8	6.10	50	4	14.0
34540.W0228	Steel	M 8	6.10	63	4	18.0
34540.W0248	Steel	M10	7.80	40	5	16.0
34540.W0250	Steel	M10	7.80	50	5	21.0
34540.W0254	Steel	M10	7.80	63	5	27.0
34540.W0258	Steel	M10	7.80	80	5	36.0
34540.W0316	Steel	M12	9.40	40	6	23.0
34540.W0320	Steel	M12	9.40	63	6	39.0
34540.W0324	Steel	M12	9.40	80	6	51.0
34540.W0328	Steel	M12	9.40	100	6	65.0
34540.W0710	Stainless	M 6	4.47	30	3	5.1
34540.W0714	Stainless	M 6	4.47	40	3	5.9
34540.W0718	Stainless	M 6	4.47	50	3	7.6
34540.W0719	Stainless	M 8	6.10	25	4	5.8
34540.W0720	Stainless	M 8	6.10	40	4	11.0
34540.W0724	Stainless	M 8	6.10	50	4	14.0
34540.W0728	Stainless	M 8	6.10	63	4	18.0
34540.W0748	Stainless	M10	7.80	40	5	16.0
34540.W0750	Stainless	M10	7.80	50	5	21.0
34540.W0754	Stainless	M10	7.80	63	5	27.0
34540.W0758	Stainless	M10	7.80	80	5	36.0
34540.W0816	Stainless	M12	9.40	40	6	23.0
34540.W0820	Stainless	M12	9.40	63	6	39.0
34540.W0824	Stainless	M12	9.40	80	6	51.0
34540.W0828	Stainless	M12	9.40	100	6	65.0



Thrust Pads - Self Levelling plastic

Thrust Screws

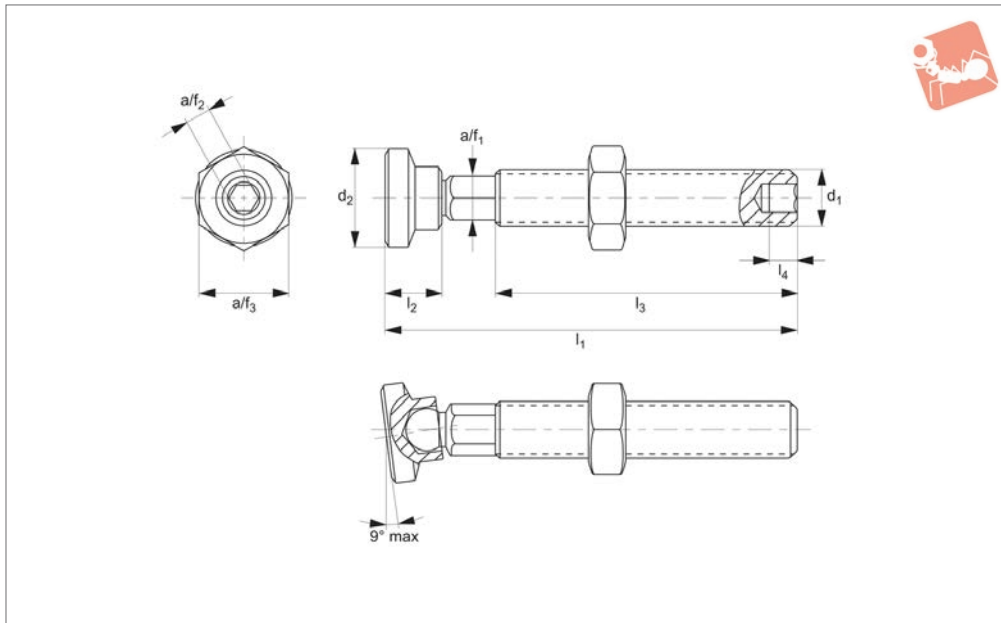

34544

THRUST SCREWS

Material

Ball: stainless steel 1.4305
Nut: stainless steel A2

Pad: Plastic (PEEK), blue

suitable for non-parallel surfaces.

Tips

For use on high quality surfaces, design is

Order No.	d ₁	d ₂	l ₁	l ₂	l ₃	l ₄	A/F ₁	A/F ₂	A/F ₃	Weight g
34544.W0005	M 5	8.5	37.0	5.0	27.0	2.5	4.0	2.5	8	6
34544.W0006	M 6	8.5	44.0	5.0	31.5	3.0	4.5	3.0	10	9
34544.W0008	M 8	12.5	63.3	8.7	49.0	4.0	6.0	4.0	13	25
34544.W0010	M10	12.5	73.3	8.7	68.9	5.0	8.0	5.0	17	48
34544.W0012	M12	16.8	84.4	12.0	64.3	6.0	9.0	6.0	19	74
34544.W0016	M16	16.8	84.4	12.0	64.0	8.0	11.0	8.0	24	125



34600

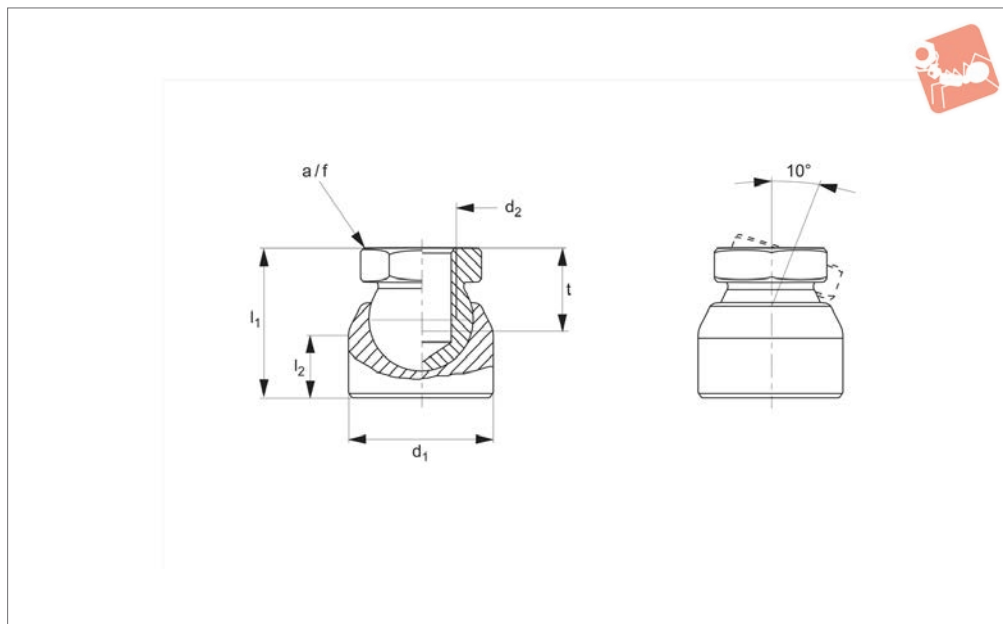

Material

Steel, tensile strength 500N/mm², zinc plated, blue passivated.

Important Notes

Pad swivels 10° from vertical in all directions.

Order No.	d ₁	d ₂	l ₁ ≈	l ₂	t min.	Static load N	A/F
34600.W0016	16	M 8	19	7	9	5000	12
34600.W0020	20	M10	22	8	11	7500	15
34600.W0024	24	M12	25	10	12	10000	17
34600.W0030	30	M16	34	13	16	15000	24



Compact Levelling Fulcrum Screw

Thrust Screws

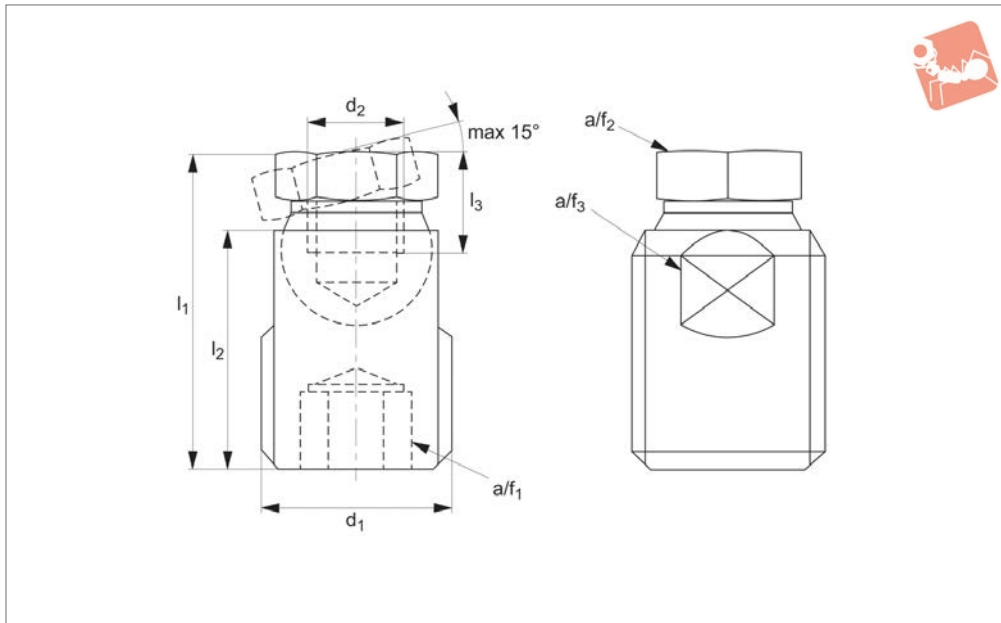

34602

THRUST SCREWS

Material steel type:

Body: heat treated steel, tempered, blackened.
Ball: free cutting steel, induction hardened.

Stainless steel type: Body and ball: stainless steel 1.4305 (AISI 1303)

Technical Notes

Can be used as foot or thrust pad.
Compact design for simple levelling by

means of the spanner flat at the bushing or preferably by means of a hexagon socket.

Should only be used for static loads

Order No.	Finish	d ₁	d ₂	l ₁ ±0.5	l ₂	l ₃ min.	A/F ₁	A/F ₂	A/F ₃	Static load kN max.	Weight g
34602.W0006	Steel	M12	M 6	21.2	16	5.0	6	9	10	10	11
34602.W0008	Steel	M16	M 8	26.5	20	7.0	8	12	14	18	24
34602.W0010	Steel	M24	M10	39.9	30	9.0	12	19	20	35	87
34602.W0012	Steel	M24	M12	39.9	30	9.0	12	19	20	35	82
34602.W0016	Steel	M30x2	M16	47.4	36	13.5	12	24	27	45	165
34602.W0206	Stainless	M12	M 6	21.2	16	5.0	6	9	10	8	11
34602.W0208	Stainless	M16	M 8	26.5	20	7.0	8	12	14	14	24
34602.W0210	Stainless	M24	M10	39.9	30	9.0	12	19	20	28	87
34602.W0212	Stainless	M24	M12	39.9	30	9.0	12	19	20	28	82
34602.W0216	Stainless	M30x2	M16	47.4	36	13.5	12	24	27	36	165

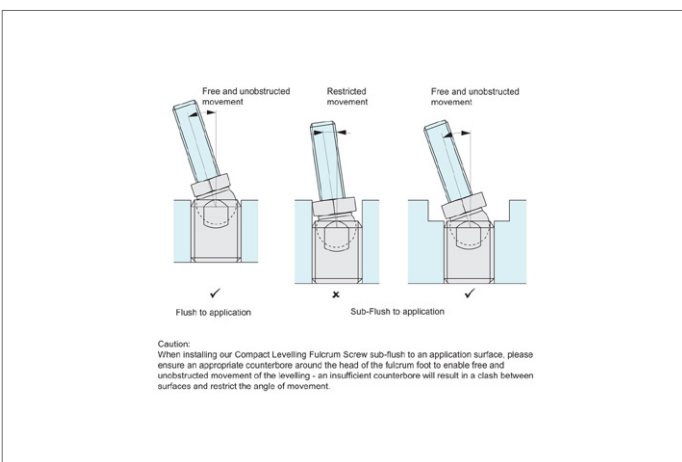



34090

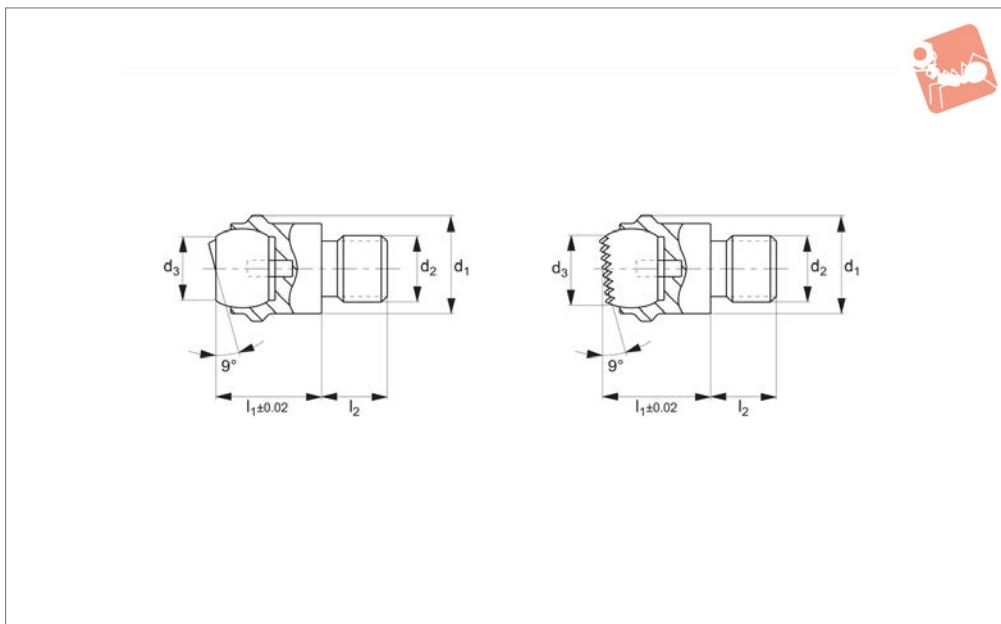

Material

Spring element: thermoplastic PUR.
 Ball: Ball-bearing steel, hardened, bright, stainless steel 1.3541, nickel-plated.
 Body: Heat-treated steel, tempered, phos-

phated. stainless steel 1.4057, heat-treated.

loading capacity valid for steel and stainless steel design.

Technical Notes

Ball protected against rotating.

Order No.	Material	Ball	d ₁	d ₂	d ₃	l ₁	l ₂	A/F	Load capacity for static load		Tightening torque	Weight g
									kN max.	Nm max.		
34090.W0012	Steel Plain Surface	10	13	M 6	7.2	13	8	11	10	13	13	
34090.W0013	Steel Plain Surface	10	13	M 8	7.2	13	8	11	10	14	14	
34090.W0018	Steel Plain Surface	16	20	M 8	10.5	18	10	17	25	25	39	
34090.W0019	Steel Plain Surface	16	20	M10	10.5	18	10	17	25	46	40	
34090.W0020	Steel Plain Surface	16	20	M10	10.5	18	10	17	25	46	44	
34090.W0030	Steel Plain Surface	25	30	M16	20	27	16	27	90	206	153	
34090.W0050	Steel Plain Surface	40	50	M20	34.5	35	20	41	165	407	491	
34090.W0060	Steel Plain Surface	40	50	M24	34.5	35	24	41	165	698	526	
34090.W0112	Stainless Plain Surface	10	13	M 6	7.2	13	8	11	10	13	13	
34090.W0113	Stainless Plain Surface	10	13	M 8	7.2	13	8	11	10	14	14	
34090.W0118	Stainless Plain Surface	16	20	M 8	10.5	18	10	17	25	25	39	
34090.W0119	Stainless Plain Surface	16	20	M10	10.5	18	10	17	25	46	40	
34090.W0120	Stainless Plain Surface	16	20	M10	10.5	18	10	17	25	46	44	
34090.W0130	Stainless Plain Surface	25	30	M16	20	27	16	27	90	206	153	
34090.W0150	Stainless Plain Surface	40	50	M20	34.5	35	20	41	165	407	491	
34090.W0160	Stainless Plain Surface	40	50	M24	34.5	35	24	41	165	698	526	
34090.W0312	Steel Ribbed Surface	10	13	M 6	7.2	13	8	11	10	13	13	
34090.W0313	Steel Ribbed Surface	10	13	M 8	7.2	13	8	11	10	14	14	
34090.W0318	Steel Ribbed Surface	16	20	M 8	10.5	18	10	17	25	25	39	
34090.W0319	Steel Ribbed Surface	16	20	M10	10.5	18	10	17	25	46	40	
34090.W0320	Steel Ribbed Surface	16	20	M10	10.5	18	10	17	25	46	44	
34090.W0330	Steel Ribbed Surface	25	30	M16	20	27	16	27	90	206	153	
34090.W0350	Steel Ribbed Surface	40	50	M20	34.5	35	20	41	165	407	491	
34090.W0360	Steel Ribbed Surface	40	50	M24	34.5	35	24	41	165	698	526	



Self-Aligning Pads

Self-Aligning Pads



Self-Aligning Pads

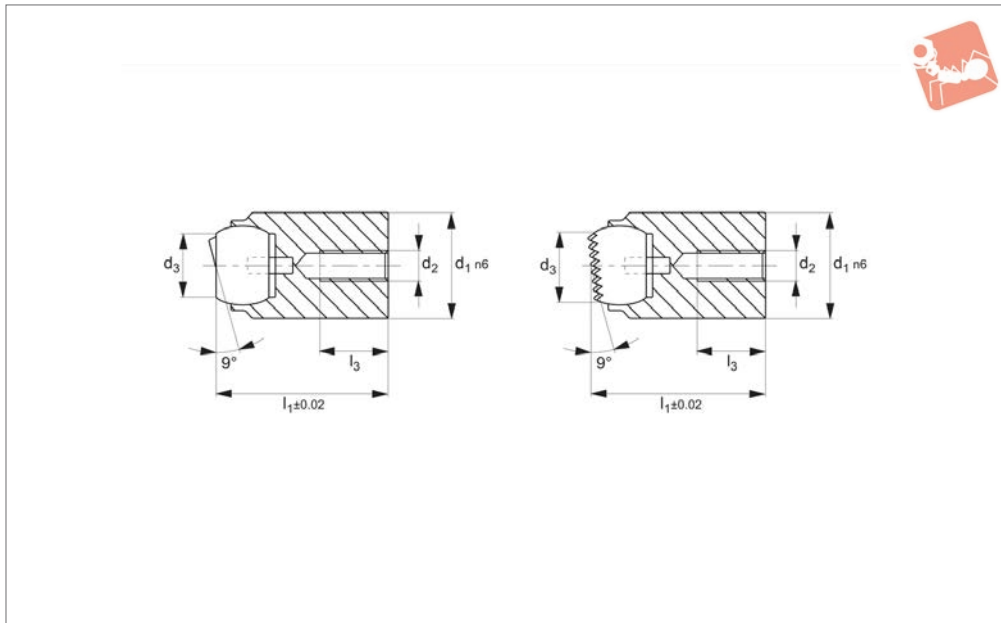

34091

SELF-ALIGNING PADS

Material

Spring element: thermoplastic PUR.
 Ball: Ball-bearing steel, hardened, bright.
 stainless steel 1.3541, nickel-plated.
 Body: Heat-treated steel, tempered, phos-

phated. stainless steel 1.4057, heat-treated.

loading capacity valid for steel and stainless steel design.

Technical Notes

Ball protected against rotating.

Order No.	Material	Ball	d ₁	d ₂	d ₃	Weight g
34091.W0412	Steel Plain Surface	10	12 tol. n6	M 3	7.2	14
34091.W0418	Steel Plain Surface	16	18 tol. n6	M 4	10.5	40
34091.W0428	Steel Plain Surface	25	28 tol. n6	M 5	20.0	150
34091.W0452	Stainless Plain Surface	10	12 tol. n6	M 3	7.2	14
34091.W0458	Stainless Plain Surface	16	18 tol. n6	M 4	10.5	40
34091.W0468	Stainless Plain Surface	25	28 tol. n6	M 5	20.0	150
34091.W0712	Steel Ribbed Surface	10	12 tol. n6	M 3	7.2	14
34091.W0718	Steel Ribbed Surface	16	18 tol. n6	M 4	10.5	40
34091.W0728	Steel Ribbed Surface	25	28 tol. n6	M 5	20.0	150

Order No.	l ₁	l ₃ max.	H7 diameter	Load capacity for static load kN max.	Depth min.	Tightening torque Nm max.
34091.W0412	17	3.2	12	10	12	1.3
34091.W0418	23	4.0	18	25	14	2.9
34091.W0428	34	6.0	28	90	22	6.0
34091.W0452	17	3.2	12	10	12	1.3
34091.W0458	23	4.0	18	25	14	2.9
34091.W0468	34	6.0	28	90	22	6.0
34091.W0712	17	3.2	12	10	12	1.3
34091.W0718	23	4.0	18	25	14	2.9
34091.W0728	34	6.0	28	90	22	6.0



34100

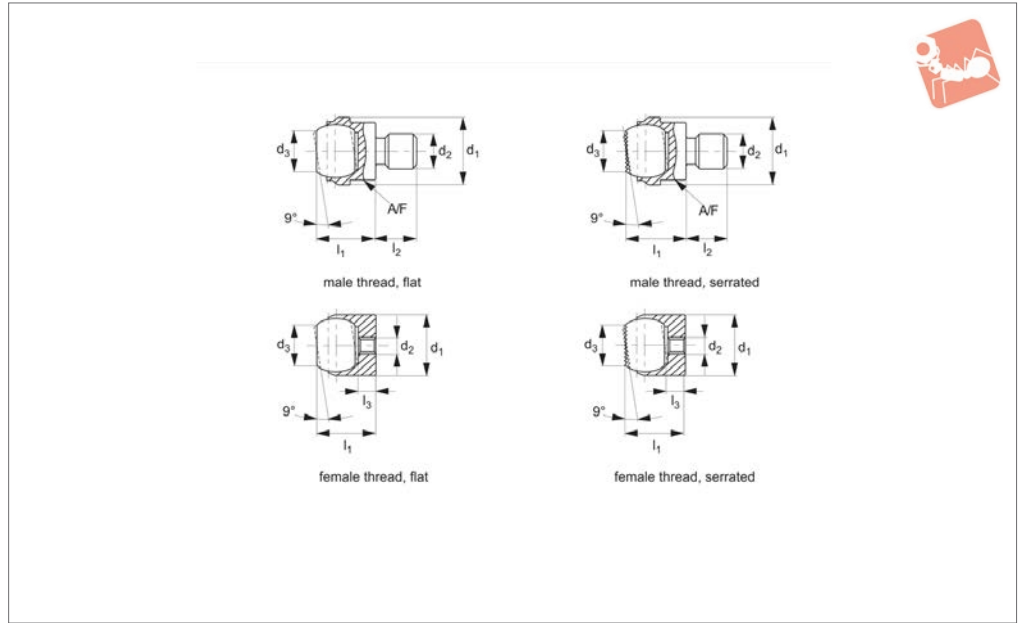

Material

Body: steel, heat-treated, phosphated.
Ball: ball bearing steel, hardened, bright.

supports and thrust elements in jigs and fixtures. They can also be fitted to existing clamping elements.

applies only when the minimum location hole depth is adhered to.
Ball secured against turning.

Technical Notes

These self-aligning pads serve as stops,

Tips

Max. load* for female threads (see table)

Order No.	Thread and face type	Ball dia.	d ₁	d ₂	d ₃	l ₁ ±0.02	l ₂ -0.5	l ₃ max.	A/F	Location hole tol. H7	Static load kN max.	Tightening torque Nm max.	Weight g
34100.W0012	Male, Flat	10	13	M 6	7,2	13	8	11			10	10	12
34100.W0013	Male, Flat	10	13	M 8	7,2	13	8	11			10	25	13
34100.W0018	Male, Flat	16	20	M 8	10,5	18	10	17			25	25	39
34100.W0019	Male, Flat	16	20	M10	10,5	18	10	17			25	46	41
34100.W0020	Male, Flat	16	20	M12	10,5	18	12	17			25	82	44
34100.W0030	Male, Flat	25	30	M16	20,0	27	16	27			90	206	151
34100.W0050	Male, Flat	40	50	M20	34,5	35	20	41			165	407	489
34100.W0060	Male, Flat	40	50	M24	34,5	35	24	41			165	698	526
34100.W0312	Male, Serrated	10	13	M 6	7,2	13	8	11			10	10	12
34100.W0313	Male, Serrated	10	13	M 8	7,2	13	8	11			10	25	13
34100.W0318	Male, Serrated	16	20	M 8	10,5	18	10	17			25	25	38
34100.W0319	Male, Serrated	16	20	M10	10,5	18	10	17			25	46	40
34100.W0320	Male, Serrated	16	20	M12	10,5	18	12	17			25	82	43
34100.W0330	Male, Serrated	25	30	M16	20,0	27	16	27			90	206	150
34100.W0350	Male, Serrated	40	50	M20	34,5	35	20	41			165	407	486
34100.W0360	Male, Serrated	40	50	M24	34,5	35	24	41			165	698	521
34100.W0412	Female, Flat	10	12 tol. n ₆	M 3	7,2	11		3,2		Ø12x6min	10*	1,3	8
34100.W0418	Female, Flat	16	18 tol. n ₆	M 4	10,5	17		4,0		Øx18x8min	25*	2,9	29
34100.W0428	Female, Flat	25	28 tol. n ₆	M 5	20,0	25		5,5		Ø28x13min	90*	6,0	109
34100.W0712	Female, Serrated	10	12 tol. n ₆	M 3	7,2	11		3,2		Ø12x6min	10*	1,3	8
34100.W0718	Female, Serrated	16	18 tol. n ₆	M 4	10,5	17		4,0		Ø18x8min	25*	2,9	29
34100.W0728	Female, Serrated	25	28 tol. n ₆	M 5	20,0	25		5,5		Ø28x13min	90*	6,0	108



Self-Aligning Pads

fixed - steel



Self-Aligning Pads

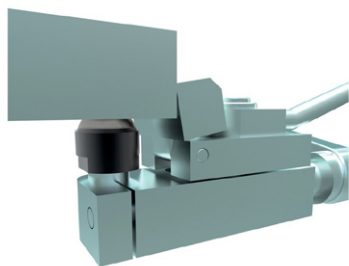

SELF-ALIGNING PADS



34101

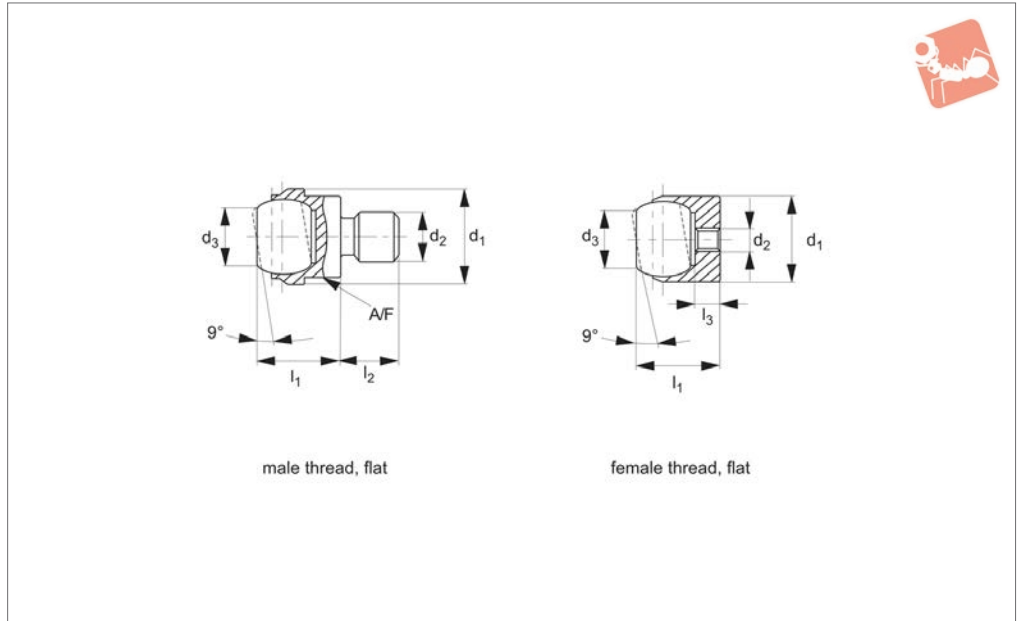

Material

Body: stainless steel (AISI 431, 1.4057), heat-treated.

Ball: stainless steel (1.3541), nickel plated.

Technical Notes

These self-aligning pads serve as stops,

supports and thrust elements in jigs and fixtures. They can also be fitted to existing clamping elements.

Tips

Max. load* for female threads (see table) applies only when the minimum location hole depth is adhered to.

Ball secured against turning.

Order No.	Thread and face type	Ball dia.	d ₁	d ₂	d ₃	Weight g
34101.W0112	Male, Flat	10	13	M 6	7.2	12
34101.W0113	Male, Flat	10	13	M 8	7.2	13
34101.W0118	Male, Flat	16	20	M 8	10.5	39
34101.W0119	Male, Flat	16	20	M10	10.5	41
34101.W0120	Male, Flat	16	20	M12	10.5	44
34101.W0130	Male, Flat	25	30	M16	20.0	151
34101.W0150	Male, Flat	40	50	M20	34.5	489
34101.W0160	Male, Flat	40	50	M24	34.5	526
34101.W0452	Female, Flat	10	12 tol. n6	M 3	7.2	8
34101.W0458	Female, Flat	16	18 tol. n6	M 4	10.5	29
34101.W0468	Female, Flat	25	28 tol. n6	M 5	20.0	109

Order No.	l ₁ ±0.02	l ₂ -0.5	l ₃ max.	A/F	Location hole tol. H7	Static load kN max.	Tightening torque Nm max.
34101.W0112	13	8	-	11	-	10	10.0
34101.W0113	13	8	-	11	-	10	25.0
34101.W0118	18	10	-	17	-	25	25.0
34101.W0119	18	10	-	17	-	25	46.0
34101.W0120	18	12	-	17	-	25	82.0
34101.W0130	27	16	-	27	-	90	206.0
34101.W0150	35	20	-	41	-	165	407.0
34101.W0160	35	24	-	41	-	165	698.0
34101.W0452	11	-	3.2	-	Ø12x6min	10*	1.3
34101.W0458	17	-	4.0	-	Ø18x8min	25*	2.9
34101.W0468	25	-	5.5	-	Ø28x13min	90*	6.0



Self-Aligning Pads

adjustable - steel



Self-Aligning Pads

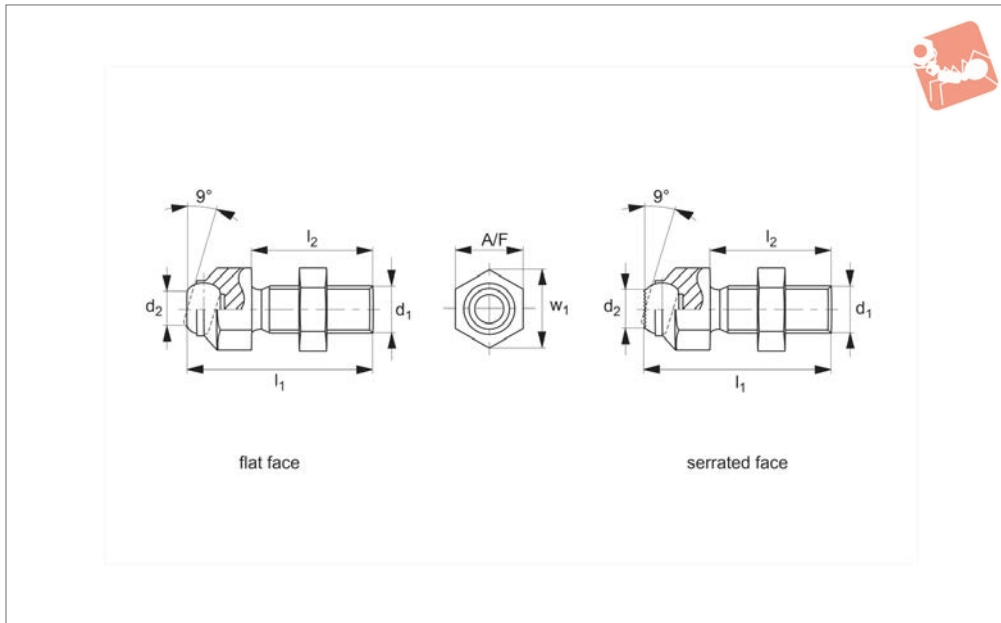

34120

SELF-ALIGNING PADS

Material

Body: steel, heat-treated, phosphated.
Ball: ball-bearing steel, hardened, bright.

supports and thrust elements in jigs and fixtures. They can also be fitted to existing clamping elements.

Tips

Ball secured against turning.

Technical Notes

These self-aligning pads serve as stops,

Order No.	Ball type	Ball dia.	d ₁	d ₂	l ₁	l ₂	w ₁	A/F	Static load kN max.	Tightening torque Nm max.	Weight g
34120.W0013	Flat, Smooth	8.5	M 8	5.8	36.6	25	14.5	13	8	25	21
34120.W0016	Flat, Smooth	12.0	M10	8.6	45.7	30	19.0	17	8	46	44
34120.W0017	Flat, Smooth	12.0	M12	8.6	50.7	35	19.0	17	15	82	55
34120.W0024	Flat, Smooth	16.0	M16	10.5	60.7	40	27.0	24	25	206	28
34120.W0030	Flat, Smooth	25.0	M20	20.0	77.3	50	33.0	30	90	407	75
34120.W0036	Flat, Smooth	25.0	M24	20.0	100.0	70	40.0	36	90	698	472
34120.W0046	Flat, Smooth	40.0	M30x1,5	34.6	100.0	65	51.0	46	165	1355	772
34120.W0313	Flat, Serrated	8.5	M 8	5.8	36.6	25	14.5	13	8	25	20
34120.W0316	Flat, Serrated	12.0	M10	8.6	45.7	30	19.0	17	8	46	44
34120.W0317	Flat, Serrated	12.0	M12	8.6	50.7	35	19.0	17	15	82	55
34120.W0324	Flat, Serrated	16.0	M16	10.5	60.7	40	27.0	24	25	206	128
34120.W0330	Flat, Serrated	25.0	M20	20.0	77.3	50	33.0	30	90	407	274
34120.W0336	Flat, Serrated	25.0	M24	20.0	100.0	70	40.0	36	90	698	472
34120.W0346	Flat, Serrated	40.0	M30x1,5	34.6	100.0	65	51.0	46	165	1355	772

Self-Aligning Pads



Self-Aligning Pads adjustable - steel



SELF-ALIGNING PADS

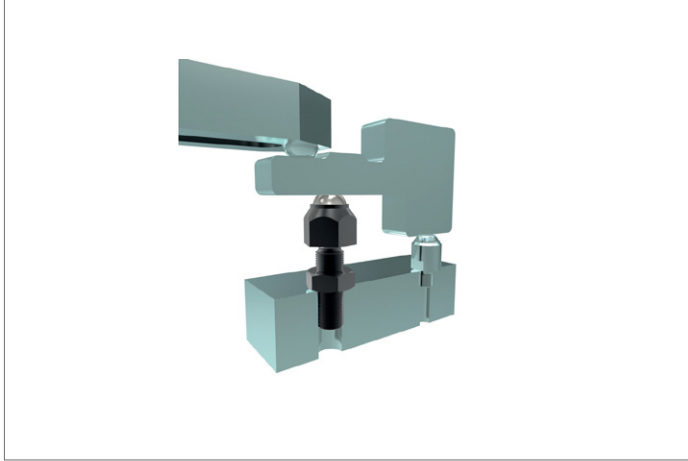



Self-Aligning Pads

adjustable - stainless steel



Self-Aligning Pads

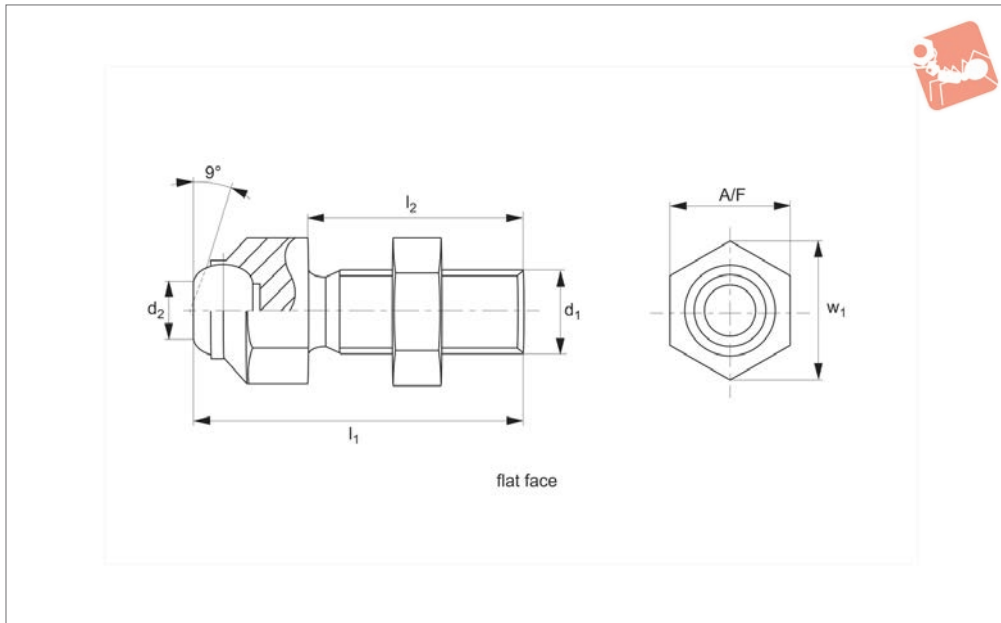

34121

SELF-ALIGNING PADS

Material

Body: stainless steel (AISI 431, 1.4057), heat-treated.

Ball: stainless steel (1.3541), nickel plated.

Nut: stainless steel.

Technical Notes

These self-aligning pads serve as stops, supports and thrust elements in jigs and

fixtures. They can also be fitted to existing clamping elements.

Tips

Ball secured against turning.

Order No.	Ball type	Ball dia.	d ₁	d ₂	l ₁	l ₂	w ₁	A/F	Static load kN max.	Tightening torque Nm max.	Weight g
34121.W0013	Flat, Smooth	8.5	M 8	5.8	36.6	25	14.5	13	8	25	20
34121.W0016	Flat, Smooth	12.0	M10	8.6	45.7	30	19.0	17	8	46	44
34121.W0017	Flat, Smooth	12.0	M12	8.6	50.7	35	19.0	17	15	82	56
34121.W0024	Flat, Smooth	16.0	M16	10.5	60.7	40	27.0	24	25	206	128
34121.W0030	Flat, Smooth	25.0	M20	20.0	77.3	50	33.0	30	90	407	275
34121.W0036	Flat, Smooth	25.0	M24	20.0	100.0	70	40.0	36	90	698	472
34121.W0046	Flat, Smooth	40.0	M30x1,5	34.6	100.0	65	51.0	46	165	1355	772

Self-Aligning Pads



Self-Aligning Pads

hard metal ball - ribbed



SELF-ALIGNING PADS

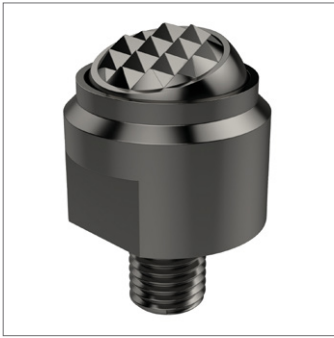

34080

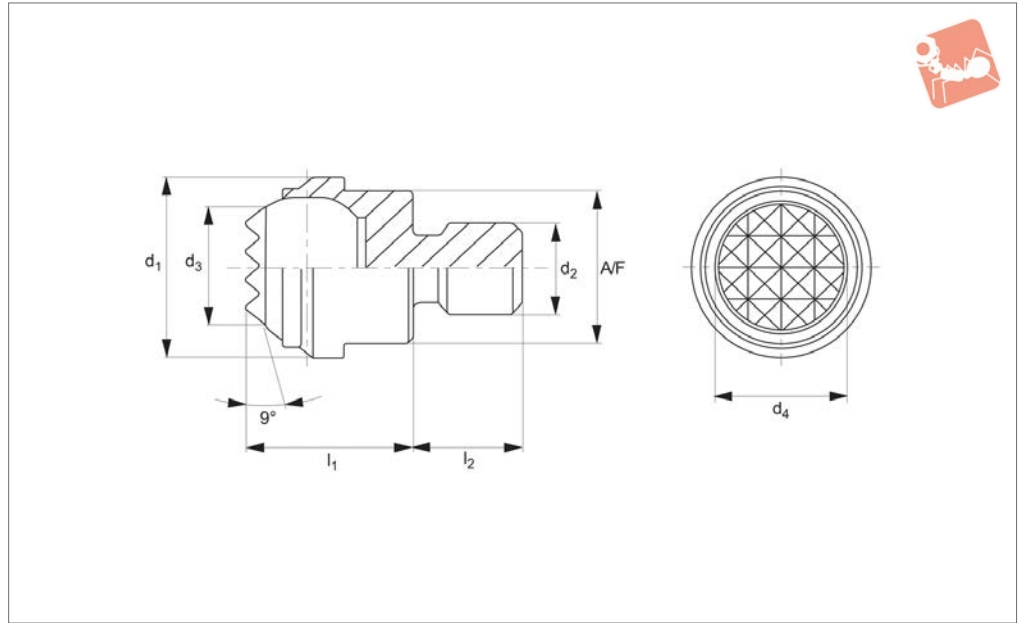

Material

Body: steel, heat-treated, phosphated.
Ball: hard metal, nickel plated.

Technical Notes

Ideal as stop, support or thrust pad especially where cast components are being machined. Insert is brazed in position.

Tips

Ball secured against turning.

Order No.	d ₁	d ₂	d ₃	d ₄	l ₁ ±0.2	l ₂ -0.5	A/F	Static load kN max.	Tightening torque Nm max.	Weight g
34080.W0362	13	M 6	8.3	10	13	8	11	10	10	14.0
34080.W0363	13	M 8	8.3	10	13	8	11	10	25	16.0
34080.W0378	20	M 8	12.8	16	18	10	17	25	25	49.0
34080.W0379	20	M10	12.8	16	18	10	17	25	46	57.0
34080.W0380	20	M12	12.8	16	18	12	17	25	82	54.0
34080.W0381	30	M16	20.0	16	27	16	27	90	206	190.0
34080.W0382	50	M20	34.5	40	35	20	41	165	407	639.0
34080.W0383	50	M24	34.5	40	35	24	41	165	698	673.0

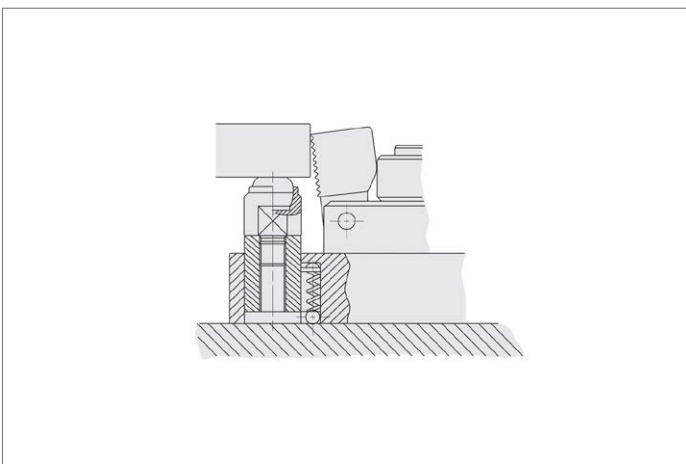



Self-Aligning Pads

hard metal ball - ribbed - stainless steel



Self-Aligning Pads

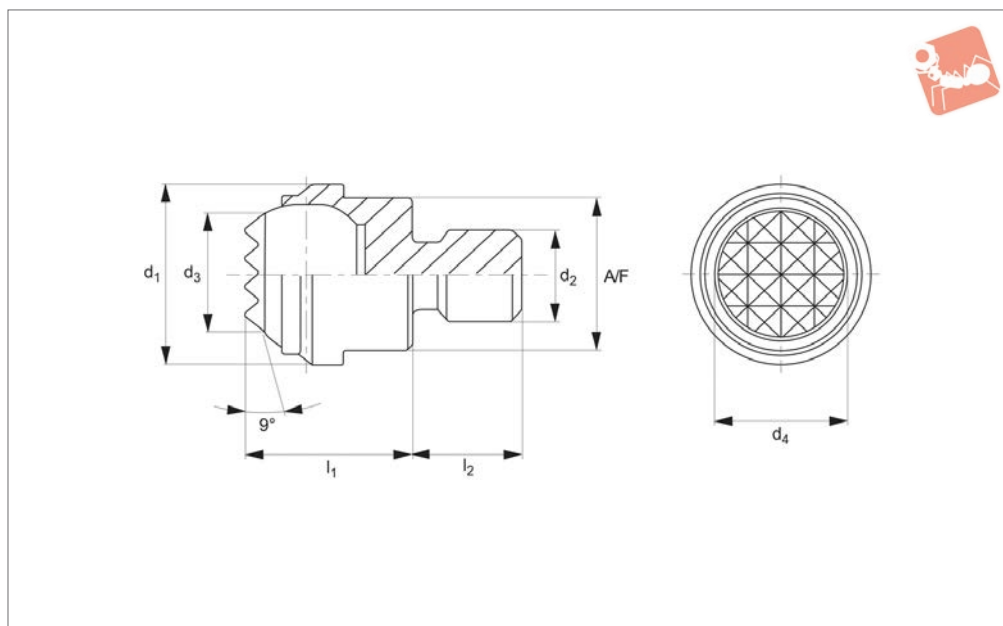

34081

SELF-ALIGNING PADS

Material

Body: stainless steel (AISI 431, 1.4057), heat treated.
Ball: hard metal, nickel plated.

Technical Notes

Ideal as stop, support or thrust pad especially where cast components are being machined. Insert is brazed in position.

Tips

Ball secured against turning.

Order No.	d ₁	d ₂	d ₃	d ₄	l ₁ ±0.2	l ₂ -0.5	A/F	Static load kN max.	Tightening torque Nm max.	Weight g
34081.W0390	13	M 6	8.3	10	13	8	11	10	10	14.0
34081.W0392	13	M 8	8.3	10	13	8	11	10	25	16.0
34081.W0394	20	M 8	12.8	16	18	10	17	25	25	49.0
34081.W0396	20	M10	12.8	16	18	10	17	25	46	51.0
34081.W0398	20	M12	12.8	16	18	12	17	25	82	54.0
34081.W0399	30	M16	20.0	25	27	16	27	90	206	190.0
34081.W0400	50	M20	34.5	40	35	20	41	165	407	639.0
34081.W0401	50	M24	34.5	40	35	24	41	165	407	673.0



34082

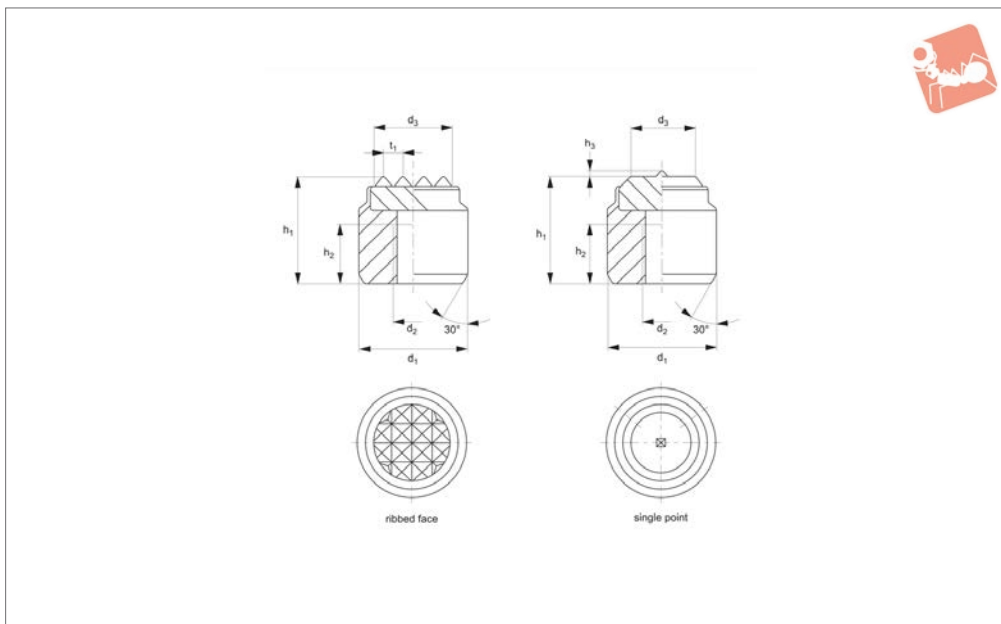

Material

Body: steel, heat-treated, phosphated.
Insert: steel, heat-treated.

Technical Notes

Ideal as stop, support or thrust pad especially where cast components are being

machined. Insert is brazed in position.

Order No.	Type	d ₁ tol. n6	d ₂	d ₃ ≈	h ₁	h ₂ min.	h ₃	t ₁	Location hole tol. H7	Weight g
34082.W0208	Ribbed Face	10	M 5	7.7	13	6	-	2	10	8
34082.W0211	Ribbed Face	14	M 6	10.6	13	6	-	2	14	15
34082.W0213	Ribbed Face	16	M 6	11.9	13	6	-	3	16	20
34082.W0215	Ribbed Face	20	M 6	16.0	13	6	-	3	20	32
34082.W0217	Ribbed Face	25	M 6	21.0	13	6	-	3	25	51
34082.W0228	Single Point	10	M 5	6.3	13	6	0.8	-	10	8
34082.W0231	Single Point	14	M 6	9.3	13	6	0.8	-	14	16
34082.W0233	Single Point	16	M 6	10.0	13	6	0.8	-	16	21

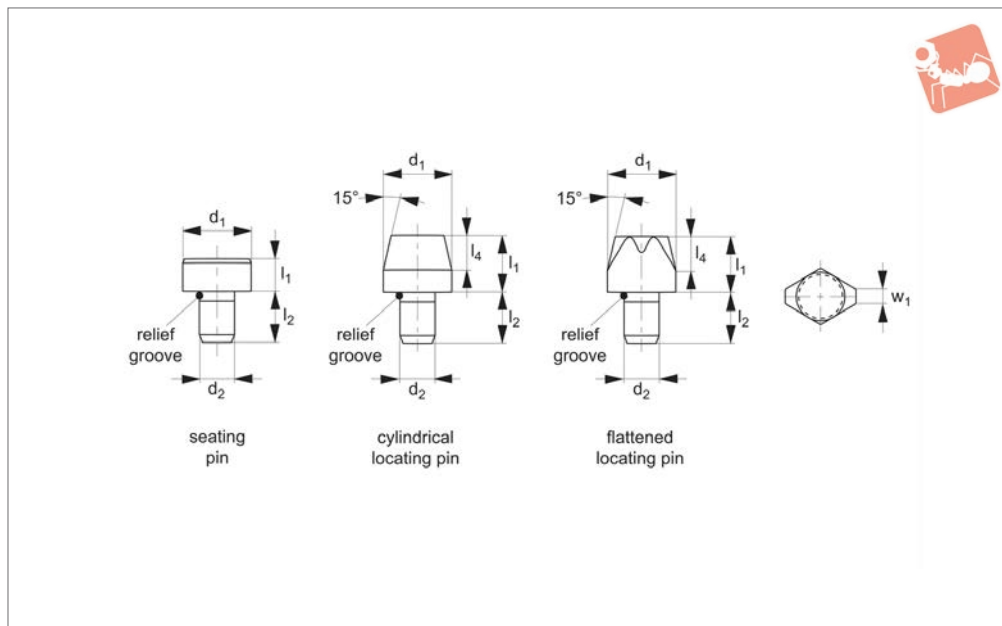

36220

LOCATING PINS

Material

Tool steel, hardened, ground. Bearing surface without centre.

Technical Notes

Produced to DIN 6321.

Cylindrical locating pins serve to locate workpieces and fixture elements into tole-

ranced holes. The flattened locating pin can be used to overcome differences in tolerances, between holes or to position an element in one direction only.

Standard seating pins 36220.W0011 to .W0014 only, have tolerance h9 on dimension l_1 , and can act as bearing

surfaces for tools and jigs.

Tips

Suggested hole tolerance for shaft d_2 , is a hole to H7.

For standard type length tolerance is h_{-9} , for all other types length tolerance is $\pm 0,1$.

Order No.	Size	Type	d_1 tol. g6	l_1	d_2 tol. n6	l_2	l_3	w_1	Weight g
36220.W0011	Short	Standard seating pin	6	5	6	6	-	-	2
36220.W0012	Short	Standard seating pin	10	6	6	9	-	-	6
36220.W0013	Short	Standard seating pin	16	8	8	12	-	-	17
36220.W0014	Short	Standard seating pin	25	10	12	18	-	-	50
36220.W0020	Short	Cylindrical locating pin	6	7	4	6	4	-	2
36220.W0021	Long	Cylindrical locating pin	6	12	4	6	6	-	3
36220.W0022	Short	Cylindrical locating pin	8	10	6	9	6	-	5
36220.W0023	Long	Cylindrical locating pin	8	16	6	9	6	-	8
36220.W0024	Short	Cylindrical locating pin	10	10	6	9	8	-	7
36220.W0025	Long	Cylindrical locating pin	10	18	6	9	9	-	12
36220.W0026	Short	Cylindrical locating pin	12	10	6	9	9	-	10
36220.W0027	Long	Cylindrical locating pin	12	18	6	9	4	-	17
36220.W0028	Short	Cylindrical locating pin	16	13	8	12	4	-	23
36220.W0029	Long	Cylindrical locating pin	16	22	8	12	6	-	36
36220.W0030	Short	Cylindrical locating pin	20	15	12	18	6	-	47
36220.W0031	Long	Cylindrical locating pin	20	25	12	18	6	-	72
36220.W0032	Short	Cylindrical locating pin	25	15	12	18	6	-	66
36220.W0033	Long	Cylindrical locating pin	25	25	12	18	6	-	106
36220.W0040	Short	Diamond locating pin	6	7	4	6	6	1.0	2
36220.W0041	Long	Diamond locating pin	6	12	4	6	8	1.0	2
36220.W0042	Short	Diamond locating pin	8	10	6	9	8	1.6	5
36220.W0043	Long	Diamond locating pin	8	16	6	9	9	1.6	6
36220.W0044	Short	Diamond locating pin	10	10	6	9	9	2.5	6
36220.W0045	Long	Diamond locating pin	10	18	6	9	9	2.5	9
36220.W0046	Short	Diamond locating pin	12	10	6	9	9	2.5	7
36220.W0047	Long	Diamond locating pin	12	18	6	9	4	2.5	11
36220.W0048	Short	Diamond locating pin	16	13	8	12	6	3.5	17
36220.W0049	Long	Diamond locating pin	16	22	8	12	6	3.5	26
36220.W0050	Short	Diamond locating pin	20	15	12	18	6	5.0	39
36220.W0051	Long	Diamond locating pin	20	25	12	18	8	5.0	55



Order No.	Size	Type	d_1 tol. g6	l_1	d_2 tol. n6	l_2	l_3	w_1	Weight g
36220.W0052	Short	Diamond locating pin	25	15	12	18	9	5.0	49
36220.W0053	Long	Diamond locating pin	25	25	12	18	9	5.0	72

LOCATING PINS

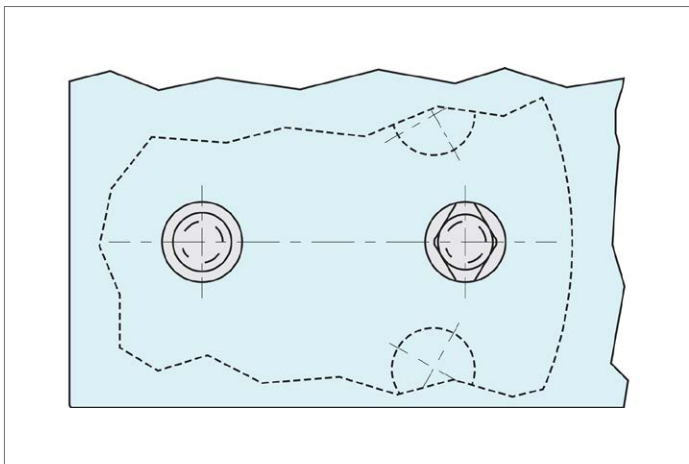



Locating Pins

with bore holes - similar to DIN 6321



Locating Pins

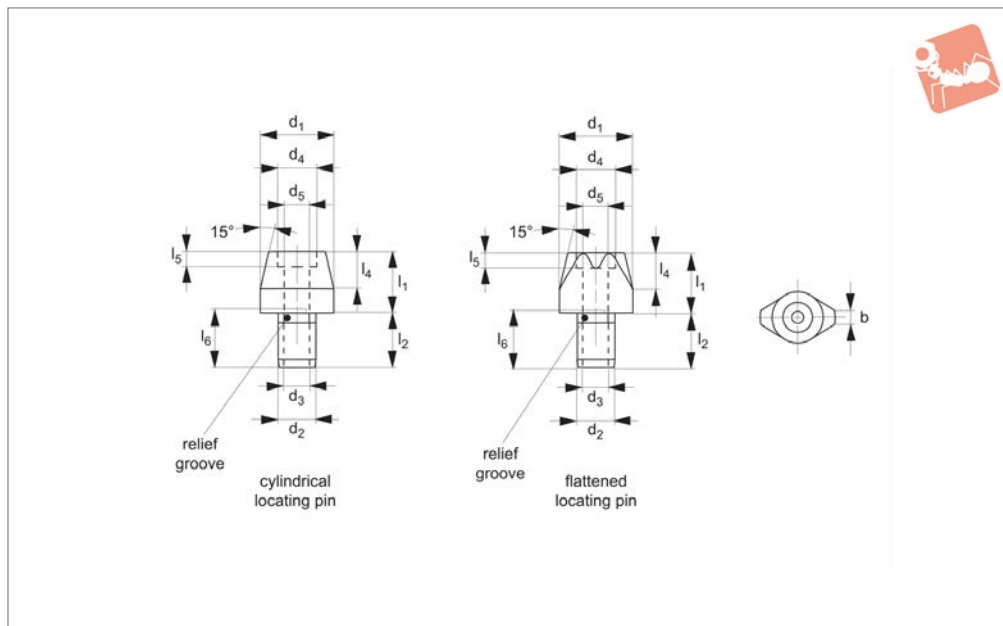

36240

LOCATING PINS

Material

Case hardened steel, blackened and ground.

Technical Notes

Cylindrical locating pins for locating work pieces in toleranced holes and also to be used as stops and feet. Flattened locating

pins used to overcome differences in tolerances, between holes or to position an element in one direction only.

Outer dimensions similar to DIN 63210.

For additional safety these parts can be secured to the jig from above, see dimension d_6 for cap screw size, or from below,

see dimension d_3 for thread size.

*** size $d_1 = 6$, can only be fixed from above.**

Suggested hole tolerance for shaft d_2 , is a hole to H7.

Order No.	Type	b	d_1 tol. g6	l_1	d_2 tol. k6	l_2	d_3	d_4	l_4	d_5	l_5	d_6	l_6	Weight g
36240.W0220	Cylindrical	-	6*	7	4	6	-	-	4	2.1	-	M2,0	-	1.2
36240.W0221	Cylindrical	-	6*	12	4	6	-	-	4	2.1	-	M2,0	-	2.0
36240.W0222	Cylindrical	-	8	10	6	9	M 3	-	6	2.6	-	M2,5	10	3.9
36240.W0223	Cylindrical	-	8	16	6	9	M 3	-	6	2.6	-	M2,5	10	6.6
36240.W0224	Cylindrical	-	10	10	6	9	M 3	5.0	6	2.6	2.6	M2,5	10	5.9
36240.W0225	Cylindrical	-	10	18	6	9	M 3	5.0	6	2.6	2.6	M2,5	10	8.5
36240.W0226	Cylindrical	-	12	10	6	9	M 3	5.0	6	2.6	2.6	M2,5	10	8.4
36240.W0227	Cylindrical	-	12	18	6	9	M 3	5.0	6	2.6	2.6	M2,5	10	10.5
36240.W0228	Cylindrical	-	16	13	8	12	M 4	6.5	8	3.3	3.1	M3,0	13	19.5
36240.W0229	Cylindrical	-	16	22	8	12	M 4	6.5	8	3.3	3.1	M3,0	13	27.7
36240.W0230	Cylindrical	-	20	15	12	18	M 6	10.0	9	5.2	5.1	M5,0	19	39.5
36240.W0231	Cylindrical	-	20	25	12	18	M 6	10.0	9	5.2	5.1	M5,0	19	53.5
36240.W0232	Cylindrical	-	25	15	12	18	M 6	10.0	9	5.2	5.1	M5,0	19	57.5
36240.W0233	Cylindrical	-	25	25	12	18	M 6	10.0	9	5.2	5.1	M5,0	19	87.5
36240.W0240	Flattened	1.0	6*	7	4	6	-	-	4	2.1	-	M2,0	-	0.7
36240.W0241	Flattened	1.0	6*	12	4	6	-	-	4	2.1	-	M2,0	-	0.9
36240.W0242	Flattened	1.6	8	10	6	9	M 3	-	6	2.6	-	M2,5	10	2.9
36240.W0243	Flattened	1.6	8	16	6	9	M 3	-	6	2.6	-	M2,5	10	4.1
36240.W0244	Flattened	2.5	10	10	6	9	M 3	5.0	6	2.6	2.6	M2,5	10	4.5
36240.W0245	Flattened	2.5	10	18	6	9	M 3	5.0	6	2.6	2.6	M2,5	10	7.4
36240.W0246	Flattened	2.5	12	10	6	9	M 3	5.0	6	2.6	2.6	M2,5	10	5.9
36240.W0247	Flattened	2.5	12	18	6	9	M 3	5.0	6	2.6	2.6	M2,5	10	9.8
36240.W0248	Flattened	3.5	16	13	8	12	M 4	6.5	8	3.3	3.1	M3,0	13	14.5
36240.W0249	Flattened	3.5	16	22	8	12	M 4	6.5	8	3.3	3.1	M3,0	13	22.2
36240.W0250	Flattened	5.0	20	15	12	18	M 6	10.0	9	5.2	5.1	M5,0	19	30.3
36240.W0251	Flattened	5.0	20	25	12	18	M 6	10.0	9	5.2	5.1	M5,0	19	43.9
36240.W0252	Flattened	5.0	25	15	12	18	M 6	10.0	9	5.2	5.1	M5,0	19	40.6
36240.W0253	Flattened	5.0	25	25	12	18	M 6	10.0	9	5.2	5.1	M5,0	19	61.7

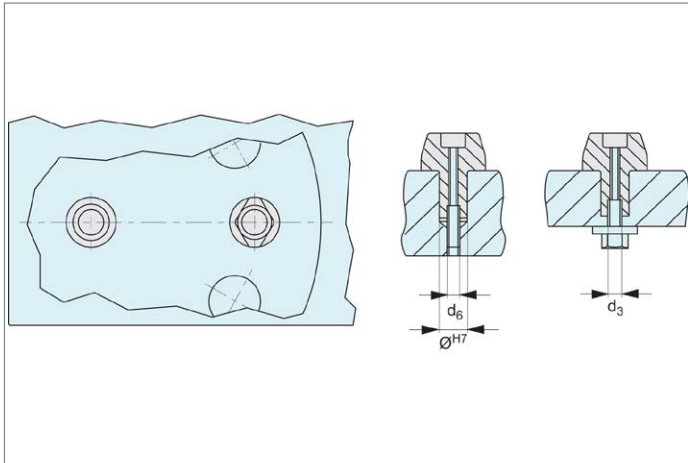

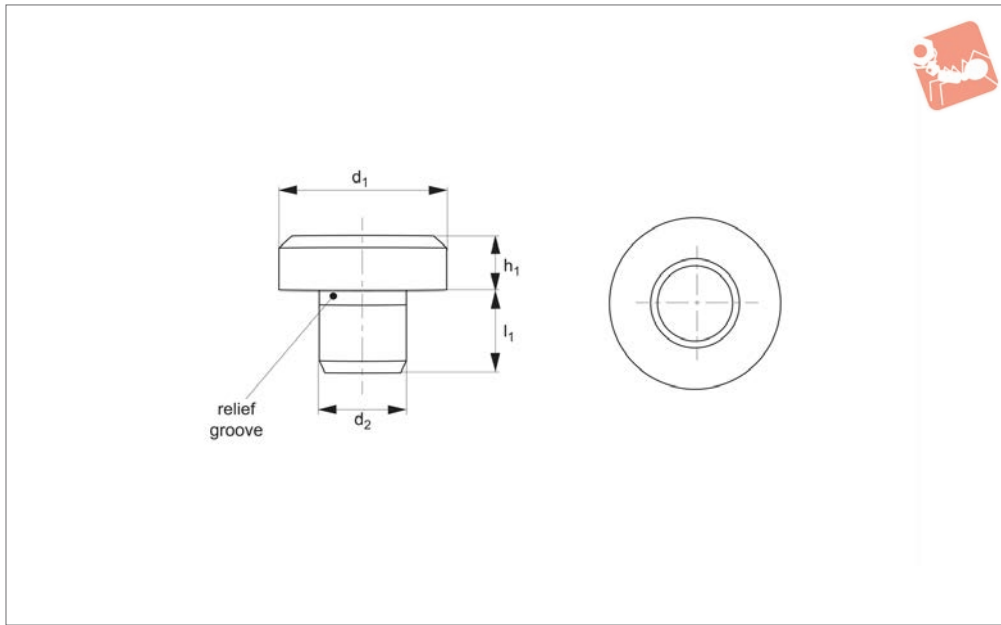

36300

LOCATING PINS

Material

Tool steel (DIN 6321), hardened and ground.

Seating pins serve as bearing surfaces for tools and jigs.

Suggested hole tolerance for shaft d_2 is a hole to N6.

Technical Notes

Bearing surface without centering.

Order No.	Type	d_1	l_1	d_2 tol. N6	h_1 tol. H9	Location hole = d_2 to tol. H7	Weight g
36300.W0001	DIN 6321 Standard	6	6.0	4	5.0	4	1.8
36300.W0002	DIN 6321 Standard	10	8.0	6	8.0	6	6.5
36300.W0003	DIN 6321 Standard	16	10.0	8	5.0	8	11
36300.W0004	DIN 6321 Standard	16	10.0	8	13.0	8	24
36300.W0005	DIN 6321 Standard	25	14.0	12	8.0	12	41
36300.W0006	DIN 6321 Standard	25	14.0	12	20.0	12	88
36300.W0007	DIN 6321 Standard	40	20.0	20	13.0	20	171
36300.W0008	DIN 6321 Standard	40	20.0	20	32.0	20	358
36300.W0110	Intermediate Sizes	6	6.5	4	2.5	4	1.2
36300.W0112	Intermediate Sizes	6	8.5	4	4.5	4	1.9
36300.W0116	Intermediate Sizes	8	8.0	5	4.0	5	3.1
36300.W0118	Intermediate Sizes	8	8.0	5	7.0	5	4.2
36300.W0120	Intermediate Sizes	10	8.5	6	4.5	6	4.4
36300.W0124	Intermediate Sizes	12	10.0	6	6.0	6	7.6
36300.W0126	Intermediate Sizes	12	10.0	6	10.0	6	11
36300.W0130	Intermediate Sizes	20	12.0	10	6.0	10	21
36300.W0132	Intermediate Sizes	20	12.0	10	12.0	10	36
36300.W0135	Intermediate Sizes	25	14.0	12	30.0	12	125
36300.W0137	Intermediate Sizes	30	20.0	16	25.0	16	164
36300.W0140	Intermediate Sizes	30	20.0	16	40.0	16	248
36300.W0144	Intermediate Sizes	30	20.0	16	50.0	16	305
36300.W0148	Intermediate Sizes	30	20.0	16	65.0	16	385
36300.W0152	Intermediate Sizes	30	20.0	20	80.0	20	485
36300.W0156	Intermediate Sizes	30	20.0	20	100.0	20	594



LOCATING PINS

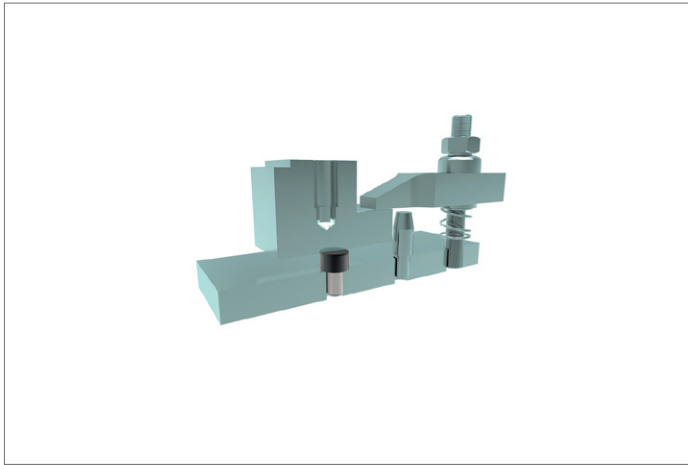



Location Pins ball end



Locating Pins

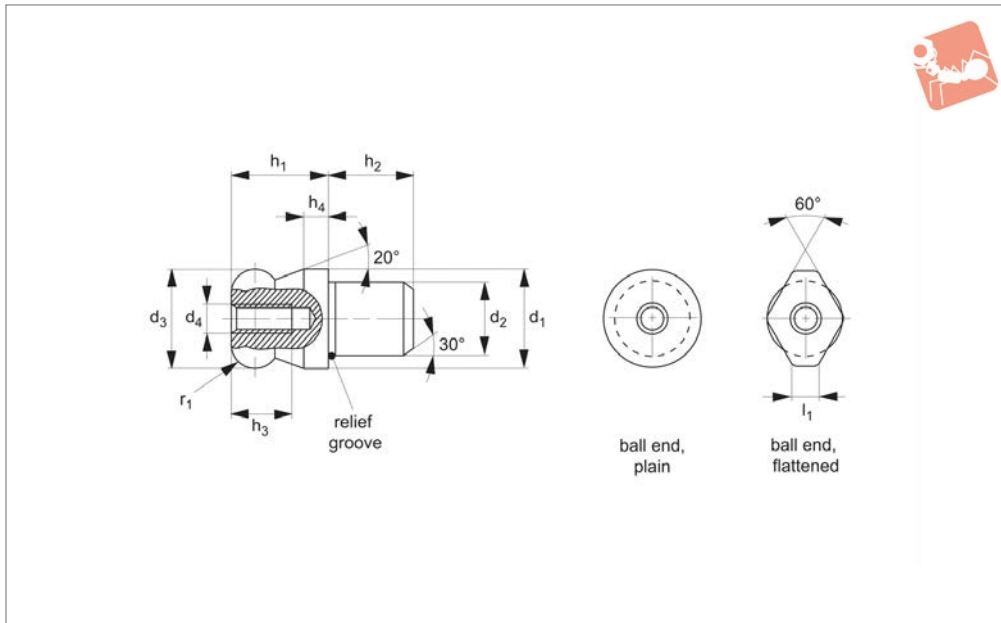

36340

LOCATING PINS

Material

Steel type:

Tool steel, hardened, blackened and ground.

Stainless steel type:

Stainless steel (AISI 303, 1.4305), ground, surface heat-treated.

Technical Notes

Ball ended straight pins facilitate inserting

workpieces and avoid clamping inclination. Suggested installation is a hole = d_2 H7 tolerance.

Order No.	Type	Material	d_1 tol. g6	l_1	d_2 tol. n6	d_3 -0.01 -0.05	d_4	h_1	h_2	h_3	h_4	r_1	Weight g
36340.W0310	Plain	Steel	10	-	7	10	M 3	10	7	6	2.5	2.5	7
36340.W0312	Plain	Steel	12	-	8	12	M 4	12	8	8	3.0	3.0	11
36340.W0316	Plain	Steel	16	-	12	16	M 5	16	12	10	4.0	4.0	30
36340.W0320	Plain	Steel	20	-	14	20	M 5	20	14	10	5.0	5.0	57
36340.W0322	Plain	Steel	22	-	16	22	M 5	22	16	10	5.5	5.5	79
36340.W0325	Plain	Steel	25	-	18	25	M 5	25	18	10	6.0	6.0	116
36340.W0410	Flattened	Steel	10	2.5	7	10	M 3	10	7	6	2.5	2.5	5
36340.W0412	Flattened	Steel	12	2.5	8	12	M 4	12	8	8	3.0	3.0	8
36340.W0416	Flattened	Steel	16	4.3	12	16	M 5	16	12	10	4.0	4.0	23
36340.W0420	Flattened	Steel	20	5.0	14	20	M 5	20	14	10	5.0	5.0	45
36340.W0422	Flattened	Steel	22	5.0	16	22	M 5	22	16	10	5.5	5.5	62
36340.W0425	Flattened	Steel	25	5.6	18	25	M 5	25	18	10	6.0	6.0	91
36340.W0350	Plain	Stainless	10	-	7	10	M 3	10	7	6	2.5	2.5	7
36340.W0352	Plain	Stainless	12	-	8	12	M 4	12	8	8	3.0	3.0	11
36340.W0356	Plain	Stainless	16	-	12	16	M 5	16	12	10	4.0	4.0	30
36340.W0360	Plain	Stainless	20	-	14	20	M 5	20	14	10	5.0	5.0	57
36340.W0450	Flattened	Stainless	10	2.5	7	10	M 3	10	7	6	2.5	2.5	5
36340.W0452	Flattened	Stainless	12	2.5	8	12	M 4	12	8	8	3.0	3.0	8
36340.W0456	Flattened	Stainless	16	4.3	12	16	M 5	16	12	10	4.0	4.0	23
36340.W0460	Flattened	Stainless	20	5.0	14	20	M 5	20	14	10	5.0	5.0	45

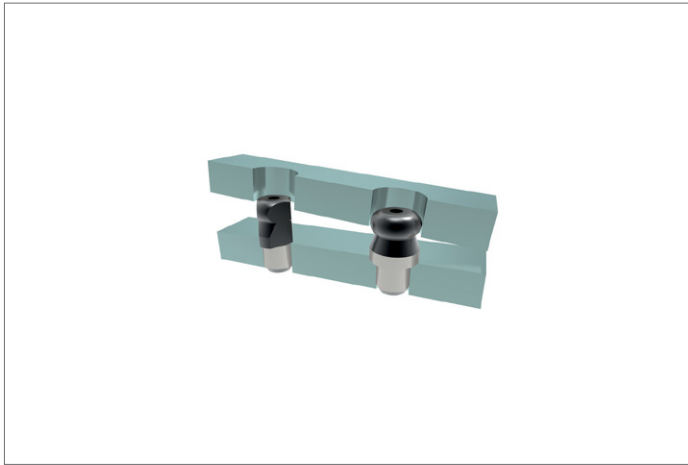
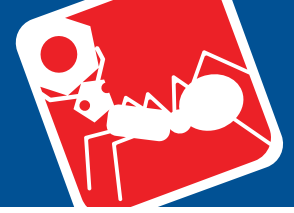

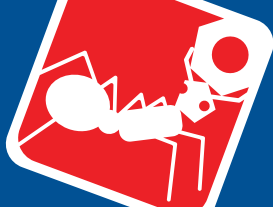

Location Pins - Non-Stepped ball end



Locating Pins

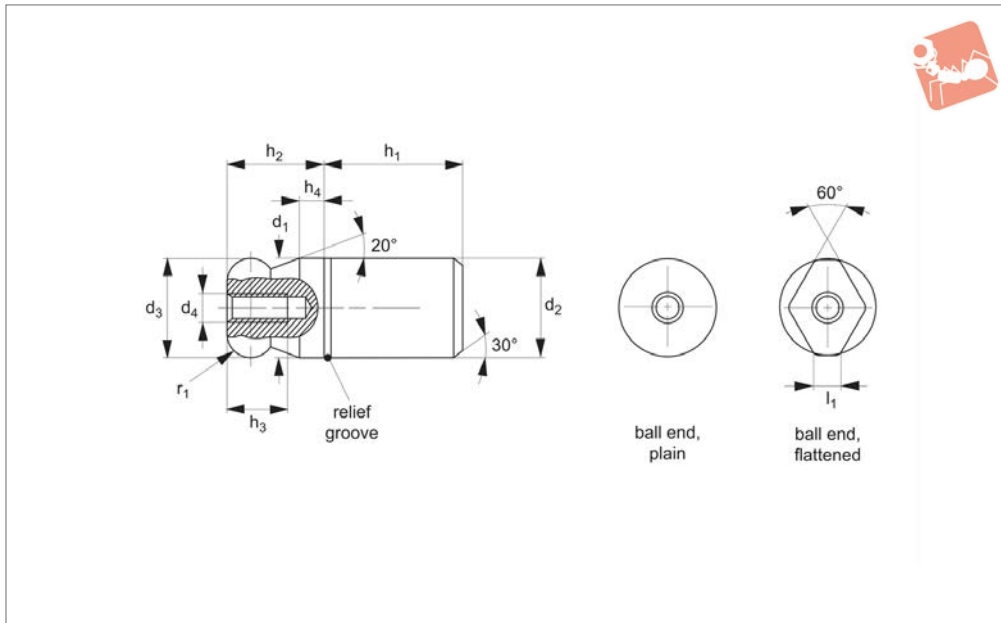

36341

LOCATING PINS

Material

Steel type:

Tool steel, hardened, ground, blackened.

Stainless steel type:

Stainless steel 1.4305 (AISI 303), ground, surface heat-treated.

Technical Notes

Ball ended straight pins facilitate inserting workpieces and avoid clamping inclination. Suggested installation is a hole = d_2 H7

Order No.	Type	Material	d_1 tol. g6	l_1	d_2 tol. n6	d_3 -0.01 -0.05	d_4	h_1	h_2	h_3	h_4	r_1	Weight g
36341.W0508	Plain	Steel	8	-	8	8	M 3	10	8	6	2.0	2.0	6
36341.W0510	Plain	Steel	10	-	10	10	M 3	13	10	6	2.5	2.5	12
36341.W0512	Plain	Steel	12	-	12	12	M 4	15	12	8	3.0	3.0	21
36341.W0516	Plain	Steel	16	-	16	16	M 5	20	16	10	4.0	4.0	51
36341.W0520	Plain	Steel	20	-	20	20	M 5	25	20	10	5.0	5.0	101
36341.W0525	Plain	Steel	25	-	25	25	M 5	25	25	10	6.0	6.0	176
36341.W0530	Plain	Steel	30	-	30	30	M 6	30	30	12	8.0	8.0	307
36341.W0540	Plain	Steel	40	-	40	40	M 6	40	40	12	10.0	10.0	729
36341.W0550	Plain	Steel	50	-	50	50	M 6	50	50	12	12.0	12.0	1422
36341.W0608	Flattened	Steel	8	1.9	8	8	M 3	10	8	6	2.0	2.0	5
36341.W0610	Flattened	Steel	10	2.5	10	10	M 3	13	10	6	2.5	2.5	11
36341.W0612	Flattened	Steel	12	2.5	12	12	M 4	15	12	8	3.0	3.0	17
36341.W0616	Flattened	Steel	16	4.3	16	16	M 5	20	16	10	4.0	4.0	44
36341.W0620	Flattened	Steel	20	5.0	20	20	M 5	25	20	10	5.0	5.0	88
36341.W0625	Flattened	Steel	25	5.6	25	25	M 5	25	25	10	6.0	6.0	149
36341.W0630	Flattened	Steel	30	8.8	30	30	M 6	30	30	12	8.0	8.0	270
36341.W0640	Flattened	Steel	40	12.8	40	40	M 6	40	40	12	10.0	10.0	657
36341.W0650	Flattened	Steel	50	16.7	50	50	M 6	50	50	12	12.0	12.0	1243
36341.W0568	Plain	Stainless	8	-	8	8	M 3	10	8	6	2.0	2.0	6
36341.W0570	Plain	Stainless	10	-	10	10	M 3	13	10	6	2.5	2.5	12
36341.W0572	Plain	Stainless	12	-	12	12	M 4	15	12	8	3.0	3.0	21
36341.W0576	Plain	Stainless	16	-	16	16	M 5	20	16	10	4.0	4.0	51
36341.W0580	Plain	Stainless	20	-	20	20	M 5	25	20	10	5.0	5.0	101
36341.W0668	Flattened	Stainless	8	1.9	8	8	M 3	10	8	6	2.0	2.0	5
36341.W0670	Flattened	Stainless	10	2.5	10	10	M 3	13	10	6	2.5	2.5	11
36341.W0672	Flattened	Stainless	12	2.5	12	12	M 4	15	12	8	3.0	3.0	17
36341.W0676	Flattened	Stainless	16	4.3	16	16	M 5	20	16	10	4.0	4.0	44
36341.W0680	Flattened	Stainless	20	5.0	20	20	M 5	25	20	10	5.0	5.0	88



LOCATING PINS



18420

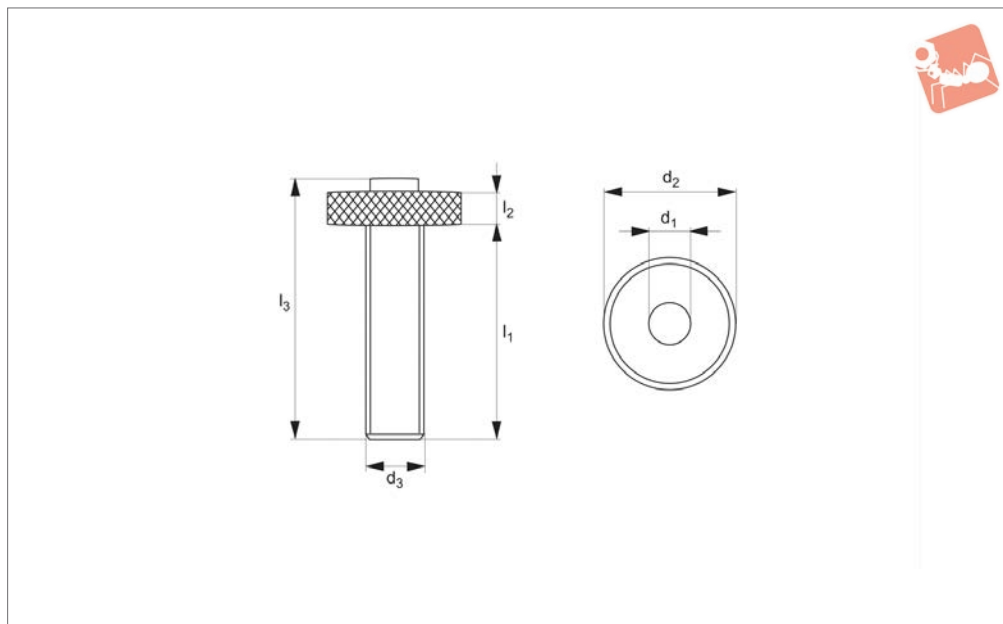

Material

Steel, heat-treated.

Order No.	d_1	d_2	d_3	l_1	l_2	l_3	Weight g
18420.W0001	12	28	M12	46	8	58	70
18420.W0002	16	34	M16	57	9	72	150

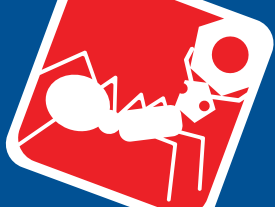

Locating Feet threaded shank

Locating Pins

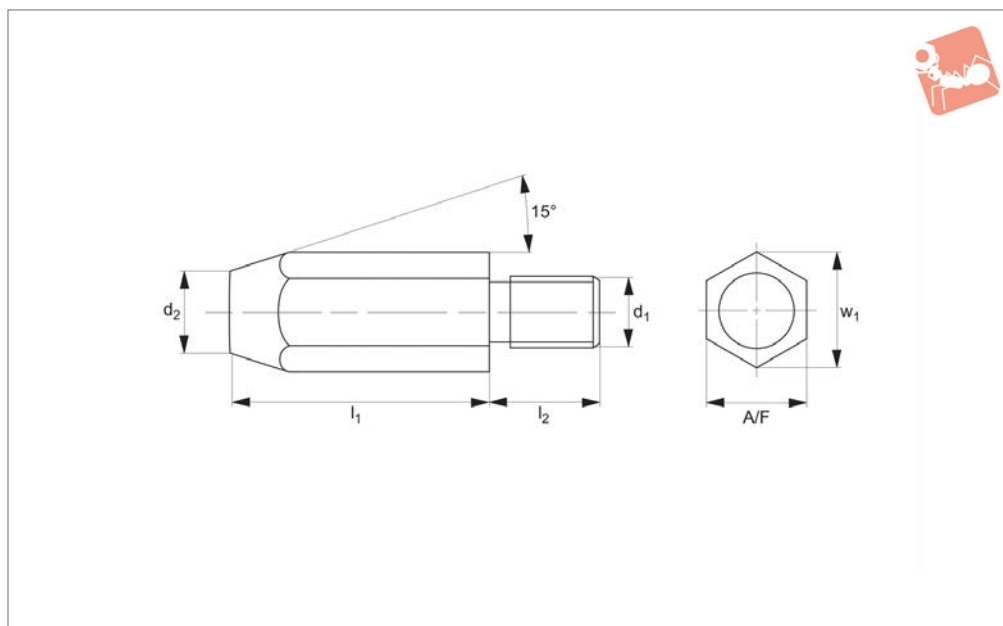

36000

LOCATING PINS

Material

Heat-treated steel (DIN 6320), blackened, turned, unhardened.

Technical Notes

Bearing surface without centre.
Locating pins nos. 36220 and 36300 can

also be used as feet.

Order No.	d ₁	l ₁	d ₂	l ₂	w ₁	A/F	Torque to Nm max.	Weight g
36000.W0061	M 6	10	8	11	11.5	10	7	8
36000.W0062	M 6	20	6	11	11.5	10	7	13
36000.W0081	M 8	15	10	13	15.0	13	7	19
36000.W0082	M 8	30	9	13	15.0	13	18	35
36000.W0101	M10	20	13	16	19.6	17	32	41
36000.W0102	M10	40	13	16	19.6	17	32	81
36000.W0121	M12	25	15	20	21.9	19	60	70
36000.W0122	M12	50	15	20	21.9	19	60	129





36200

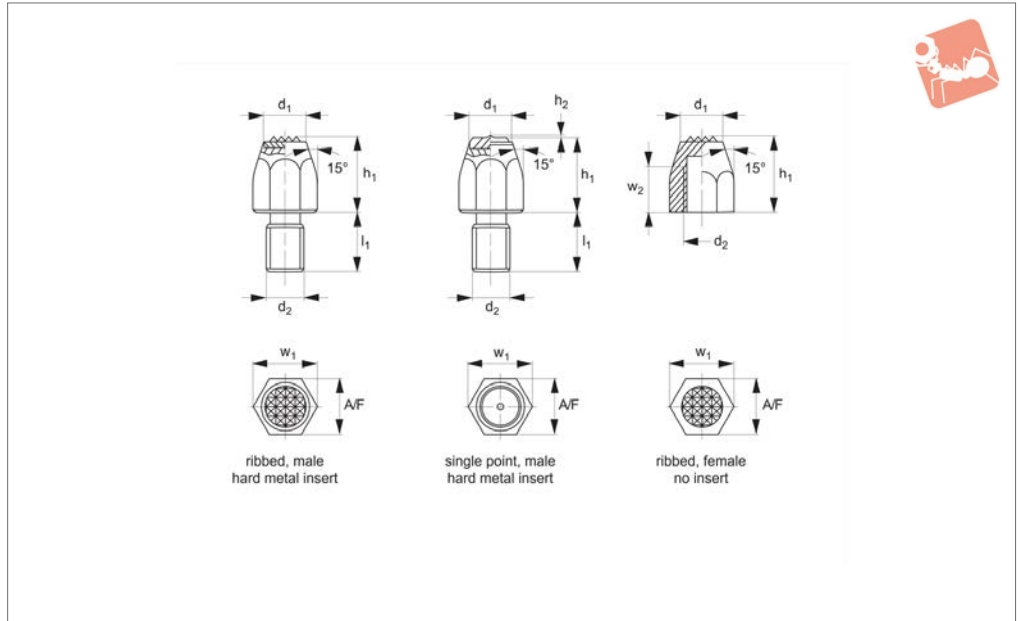

Material

With hard metal insert:

Body: heat-treated steel, tempered, blackened.

Insert: hard metal, brazed-in.

Without hard metal insert:

Body: free-cutting steel, case-hardened, blackened.

Technical Notes

For workpieces having a rough surface. The single pointed type is ideal for cast parts.

Order No.	Type	Insert material	d ₁	l ₁	d ₂	h ₁	h ₂	w ₁	w ₂	A/F	Torque to Nm max.	Weight g
36200.W0061	Ribbed, Male	Hard Metal	9.5	11	M 6	10	-	11.5	-	10	7	9
36200.W0081	Ribbed, Male	Hard Metal	12.5	13	M 8	15	-	15.0	-	13	18	22
36200.W0101	Ribbed, Male	Hard Metal	12.5	15	M10	20	-	19.6	-	17	32	40
36200.W0121	Ribbed, Male	Hard Metal	13.8	20	M12	25	-	21.9	-	19	60	64
36200.W0063	Single Point, Male	Hard Metal	9.5	11	M 6	10	0.8	11.5	-	10	7	9
36200.W0083	Single Point, Male	Hard Metal	12.5	13	M 8	15	0.8	15.0	-	13	18	23
36200.W0103	Single Point, Male	Hard Metal	12.5	15	M10	20	0.8	19.6	-	17	32	40
36200.W0123	Single Point, Male	Hard Metal	13.8	20	M12	25	0.8	21.9	-	19	60	65
36200.W0142	Ribbed, Female	W/O Insert	9.0	-	M 8	20	-	15.0	10	13	18	14
36200.W0144	Ribbed, Female	W/O Insert	9.0	-	M 8	25	-	15.0	10	13	18	20
36200.W0164	Ribbed, Female	W/O Insert	12.5	-	M10	25	-	19.6	13	17	32	1
36200.W0166	Ribbed, Female	W/O Insert	12.5	-	M10	30	-	19.6	13	17	32	40
36200.W0168	Ribbed, Female	W/O Insert	12.5	-	M10	40	-	19.6	13	17	32	60
36200.W0184	Ribbed, Female	W/O Insert	13.0	-	M12	25	-	21.9	15	19	60	33
36200.W0186	Ribbed, Female	W/O Insert	13.0	-	M12	30	-	21.9	15	19	60	44
36200.W0188	Ribbed, Female	W/O Insert	13.0	-	M12	40	-	21.9	15	19	60	69



Locating Pins

with and without hard metal insert



Locating Pins

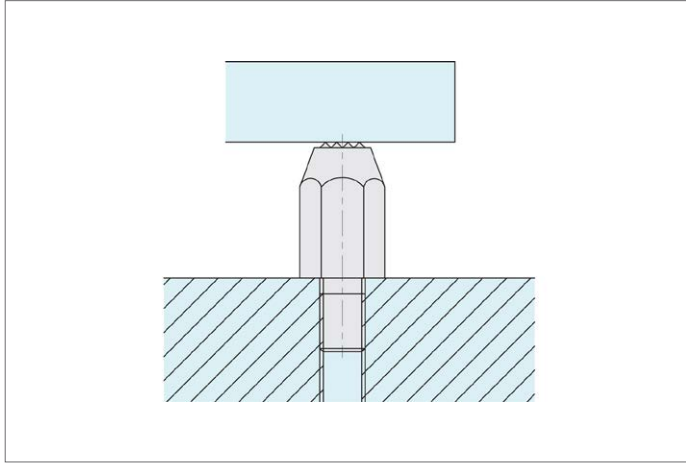

LOCATING PINS



36210

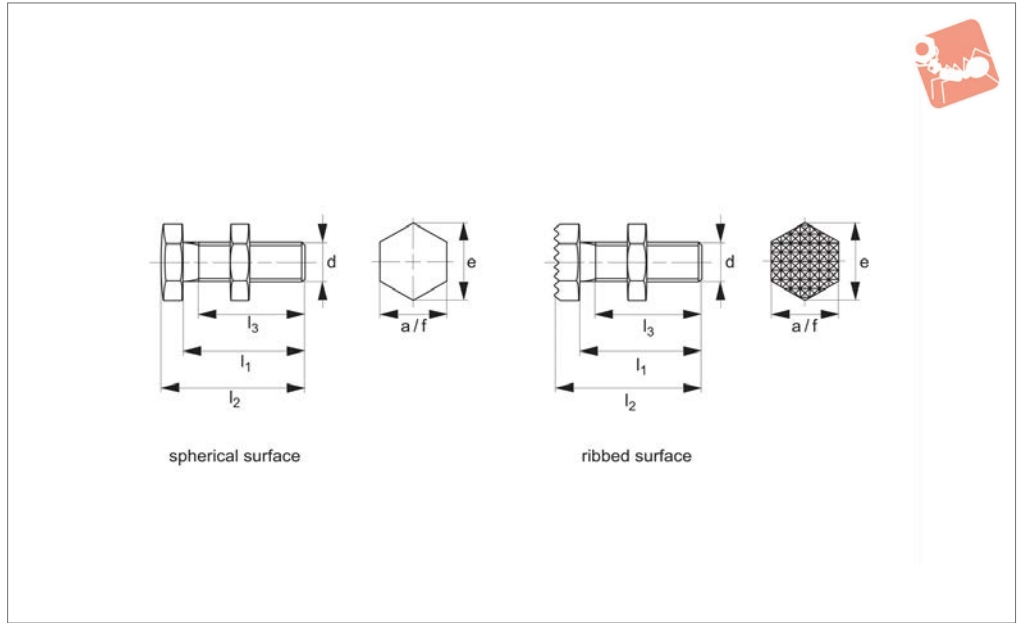

Material

Body and nut: heat treated steel, tempered, blackened and support induc-

tion hardened, quality 10,9.

Technical Notes

Ideal for use as seats and stops.

Order No.	Finish	d	l_1 ± 1.5	l_2 ± 1.5	l_3 min.	e	A/F	Weight g
36210.W0606	Spherical Surface	M 6	20	23.5	19.0	11.5	10	6.8
36210.W0608	Spherical Surface	M 8	25	30.0	21.0	14.5	13	15.0
36210.W0610	Spherical Surface	M10	30	36.0	25.5	19.6	17	31.0
36210.W0612	Spherical Surface	M12	35	42.0	29.7	21.9	19	48.0
36210.W0616	Spherical Surface	M16	40	49.5	34.0	27.7	24	99.0
36210.W0620	Spherical Surface	M20	45	57.0	37.0	34.6	30	179.0
36210.W0624	Spherical Surface	M24	50	64.0	40.0	41.6	36	294.0
36210.W0626	Ribbed Surface	M 6	20	23.5	19.0	11.5	10	6.7
36210.W0628	Ribbed Surface	M 8	25	30.0	21.0	14.5	13	15.0
36210.W0630	Ribbed Surface	M10	30	36.0	25.5	19.6	17	32.0
36210.W0632	Ribbed Surface	M12	35	42.0	29.7	21.9	19	49.0
36210.W0636	Ribbed Surface	M16	40	49.5	34.0	27.7	24	99.0
36210.W0640	Ribbed Surface	M20	45	57.0	37.0	34.6	30	177.0
36210.W0644	Ribbed Surface	M24	50	64.0	40.0	41.6	36	296.0

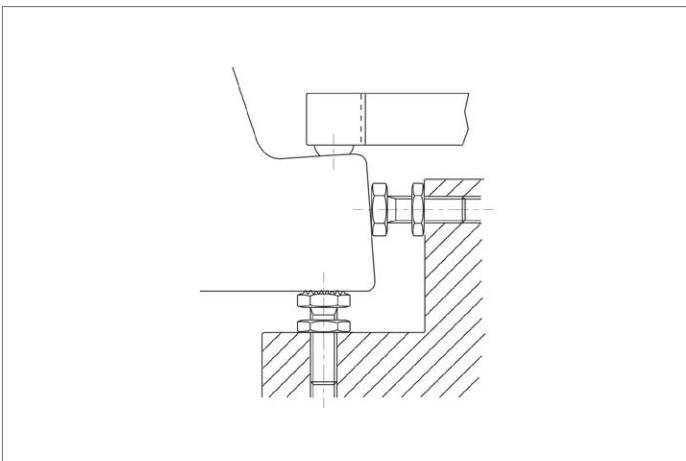



Threaded Rest Buttons male thread

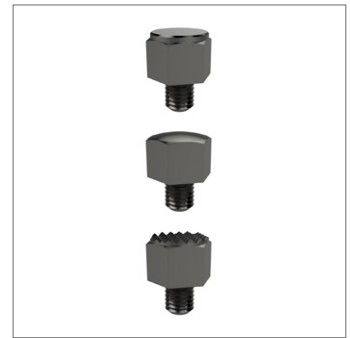
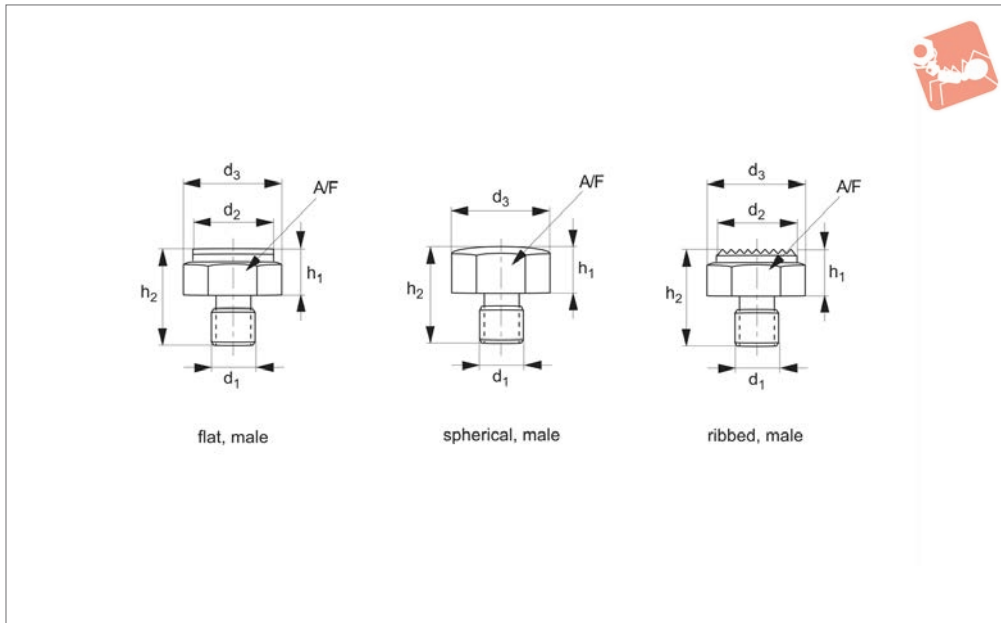

36401

LOCATING PINS

Material

Free-cutting steel, case-hardened and blackened. Thread not hardened.

Technical Notes

The buttons are used as seats, stops and

thrust pads in jigs and fixtures as well as machine and equipment design. Dimension h_1 tolerance of $\pm 0,01$ for flat face type only, other types have h_1 tolerance of $\pm 0,1$. Stated starting torque for female thread is

based on use of bolt of strength class 8 or greater and with full engagement of female thread.

Tips

For female thread see 36402.

Order No.	Type	d_1	d_2	d_3	h_1	h_2	A/F	Torque to Nm max.	Weight g
36401.W0021	Flat Face	M 8	17	19.4	10	20	17	18	21
36401.W0031	Flat Face	M10	19	21.9	10	22	19	32	28
36401.W0032	Flat Face	M10	19	21.9	15	27	19	32	40
36401.W0001	Flat Face	M12	22	25.2	10	24	22	60	34
36401.W0002	Flat Face	M12	22	25.2	15	29	22	60	56
36401.W0042	Flat Face	M16	30	33.0	15	34	30	140	110
36401.W0043	Flat Face	M16	30	33.0	20	39	30	140	140
36401.W0052	Flat Face	M20	36	40.0	20	44	36	290	214
36401.W0053	Flat Face	M20	36	40.0	25	49	36	290	257
36401.W0062	Flat Face	M24	41	46.0	20	49	41	498	300
36401.W0063	Flat Face	M24	41	46.0	25	54	41	498	356
36401.W0064	Flat Face	M24	41	46.0	30	59	41	498	412
36401.W0121	Spherical Face	M 8	-	19.4	10	20	17	18	20
36401.W0131	Spherical Face	M10	-	21.9	10	22	19	32	30
36401.W0132	Spherical Face	M10	-	21.9	15	27	19	32	40
36401.W0101	Spherical Face	M12	-	25.2	10	24	22	60	38
36401.W0102	Spherical Face	M12	-	25.2	15	29	22	60	53
36401.W0142	Spherical Face	M16	-	33.0	15	34	30	140	105
36401.W0143	Spherical Face	M16	-	33.0	20	39	30	140	135
36401.W0152	Spherical Face	M20	-	40.0	20	44	36	290	206
36401.W0153	Spherical Face	M20	-	40.0	25	49	36	290	249
36401.W0162	Spherical Face	M24	-	46.0	20	49	41	498	258
36401.W0163	Spherical Face	M24	-	46.0	25	54	41	498	342
36401.W0164	Spherical Face	M24	-	46.0	30	59	41	498	398
36401.W0221	Ribbed Face	M 8	17	19.4	10	20	17	18	21
36401.W0231	Ribbed Face	M10	19	21.9	10	22	19	32	30
36401.W0232	Ribbed Face	M10	19	21.9	15	27	19	32	41
36401.W0201	Ribbed Face	M12	22	25.2	10	24	22	60	38
36401.W0202	Ribbed Face	M12	22	25.2	15	29	22	60	54
36401.W0242	Ribbed Face	M16	30	33.0	15	34	30	140	106
36401.W0243	Ribbed Face	M16	30	33.0	20	39	30	140	136



Order No.	Type	d ₁	d ₂	d ₃	h ₁	h ₂	A/F	Torque to Nm max.	Weight g
36401.W0252	Ribbed Face	M20	36	40.0	20	44	36	290	206
36401.W0253	Ribbed Face	M20	36	40.0	25	49	36	290	253
36401.W0262	Ribbed Face	M24	41	46.0	20	49	41	498	297
36401.W0263	Ribbed Face	M24	41	46.0	25	54	41	498	353
36401.W0264	Ribbed Face	M24	41	46.0	30	59	41	498	410

LOCATING PINS

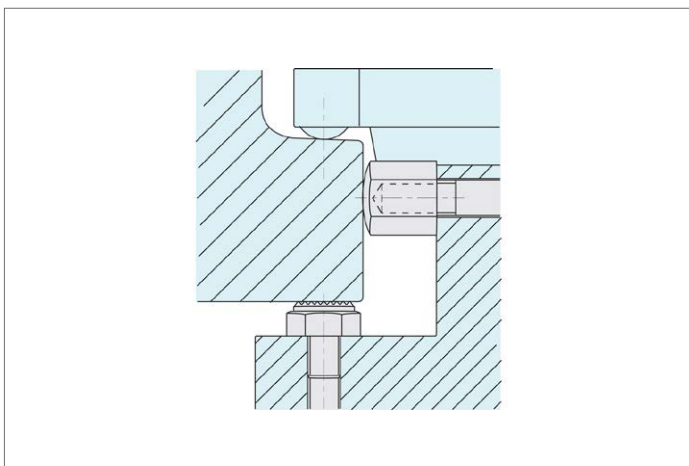



Threaded Rest Buttons

female thread



Locating Pins

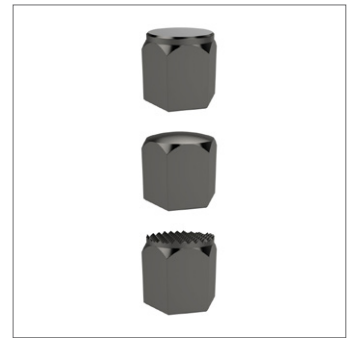
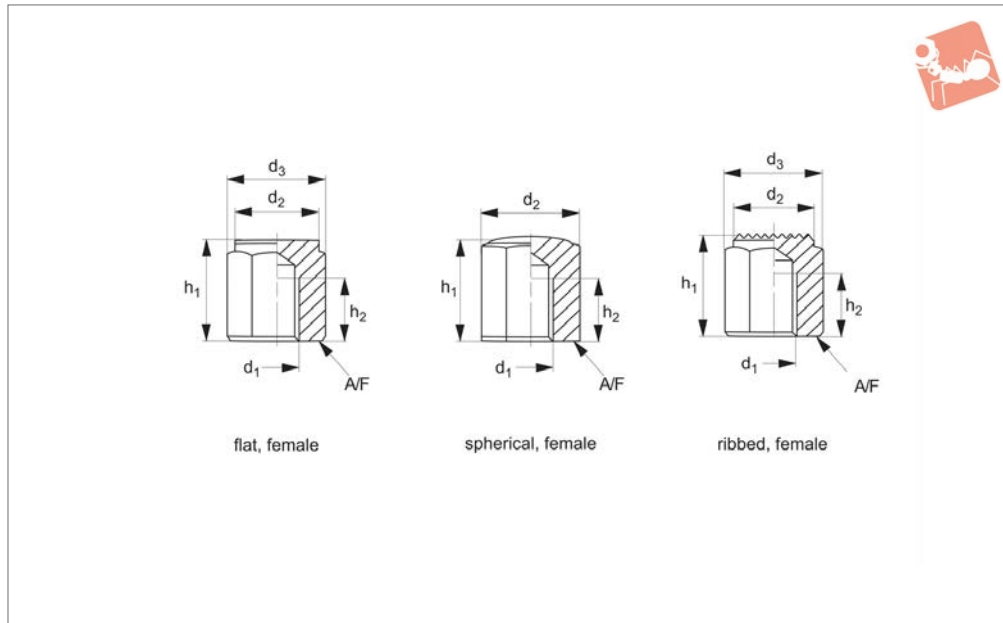

36402

LOCATING PINS

Material

Free-cutting steel, case-hardened and blackened. Thread not hardened.

Technical Notes

The buttons are used as seats, stops and thrust pads in jigs and fixtures as well as

machine and equipment design. Dimension h_1 tolerance of $\pm 0,01$ for flat face type only, other types have h_1 tolerance of $\pm 0,1$. Stated starting torque for female thread is based on use of bolt strength class 8 or greater and with full engagement of female

thread.

Tips

For male thread see 36401.

Order No.	Type	d_1	d_2	d_3	h_1	h_2	A/F	Torque to Nm max.	Weight g
36402.W0321	Flat Face	M 8	17	19.4	15	6	17	25	25
36402.W0323	Flat Face	M 8	17	19.4	25	12	17	25	42
36402.W0333	Flat Face	M10	19	21.9	20	10	19	46	40
36402.W0335	Flat Face	M10	19	21.9	30	15	19	46	61
36402.W0337	Flat Face	M10	19	21.9	40	15	19	46	85
36402.W0301	Flat Face	M12	22	25.2	20	10	22	82	52
36402.W0302	Flat Face	M12	22	25.2	25	15	22	82	65
36402.W0303	Flat Face	M12	22	25.2	30	18	22	82	79
36402.W0304	Flat Face	M12	22	25.2	40	18	22	82	111
36402.W0305	Flat Face	M12	22	25.2	50	18	22	82	142
36402.W0343	Flat Face	M16	30	33.0	30	20	30	206	140
36402.W0345	Flat Face	M16	30	33.0	50	24	30	206	257
36402.W0353	Flat Face	M20	36	40.0	40	26	36	407	279
36402.W0355	Flat Face	M20	36	40.0	60	38	36	407	431
36402.W0363	Flat Face	M24	41	46.0	40	26	41	698	341
36402.W0365	Flat Face	M24	41	46.0	60	38	41	698	530
36402.W0421	Spherical Face	M 8	-	19.4	15	6	17	25	23
36402.W0423	Spherical Face	M 8	-	19.4	25	12	17	25	41
36402.W0433	Spherical Face	M10	-	21.9	20	10	19	46	38
36402.W0435	Spherical Face	M10	-	21.9	30	15	19	46	60
36402.W0437	Spherical Face	M10	-	21.9	40	15	19	46	84
36402.W0401	Spherical Face	M12	-	25.2	20	10	22	82	50
36402.W0402	Spherical Face	M12	-	25.2	25	15	22	82	62
36402.W0403	Spherical Face	M12	-	25.2	30	18	22	82	76
36402.W0404	Spherical Face	M12	-	25.2	40	18	22	82	109
36402.W0405	Spherical Face	M12	-	25.2	50	18	22	82	141
36402.W0443	Spherical Face	M16	-	33.0	30	20	30	206	136
36402.W0445	Spherical Face	M16	-	33.0	50	24	30	206	252
36402.W0453	Spherical Face	M20	-	40.0	40	26	36	407	272
36402.W0455	Spherical Face	M20	-	40.0	60	38	36	407	423



LOCATING PINS

Order No.	Type	d ₁	d ₂	d ₃	h ₁	h ₂	A/F	Torque to Nm max.	Weight g
36402.W0463	Spherical Face	M24	-	46.0	40	26	41	698	340
36402.W0465	Spherical Face	M24	-	46.0	60	38	41	698	530
36402.W0521	Ribbed Face	M 8	17	19.4	15	6	17	25	24
36402.W0523	Ribbed Face	M 8	17	19.4	25	12	17	25	41
36402.W0533	Ribbed Face	M10	19	21.9	20	10	19	46	38
36402.W0535	Ribbed Face	M10	19	21.9	30	15	19	46	60
36402.W0537	Ribbed Face	M10	19	21.9	40	15	19	46	84
36402.W0501	Ribbed Face	M12	22	25.2	20	10	22	82	50
36402.W0502	Ribbed Face	M12	22	25.2	25	15	22	82	63
36402.W0503	Ribbed Face	M12	22	25.2	30	18	22	82	77
36402.W0504	Ribbed Face	M12	22	25.2	40	18	22	82	109
36402.W0505	Ribbed Face	M12	22	25.2	50	18	22	82	141
36402.W0543	Ribbed Face	M16	30	33.0	30	20	30	206	137
36402.W0545	Ribbed Face	M16	30	33.0	50	24	30	206	254
36402.W0553	Ribbed Face	M20	36	40.0	40	26	36	407	266
36402.W0555	Ribbed Face	M20	36	40.0	60	38	36	407	418
36402.W0563	Ribbed Face	M24	41	46.0	40	26	41	698	338
36402.W0565	Ribbed Face	M24	41	46.0	60	38	41	698	528



Screwed Rest Buttons - Plastic male thread

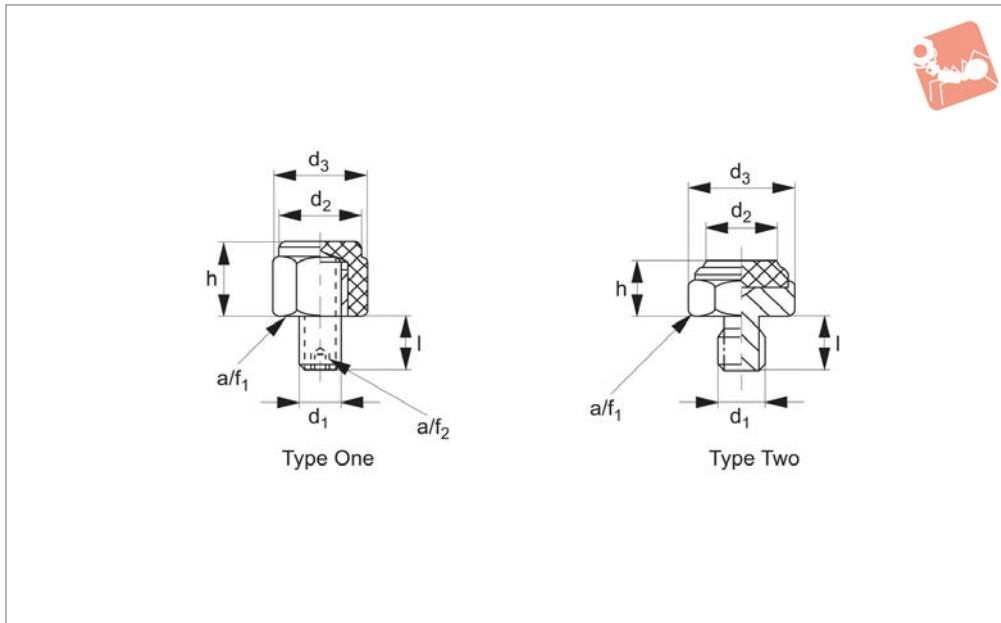

36403

LOCATING PINS

Material

Body: stainless steel 1.4305
Pad: plastic (PEEK), blue

Technical Notes

The buttons are used as seats, stops,

supports and thrust pads in jigs and fixtures as well as machine and equipment design.
Temperature range -60 to +250°C.

Tips

For female thread see 36404.

Order No.	d ₁	d ₂	d ₃	h ±0.1	l	A/F ₁	A/F ₂	Static load kN max.	Tightening torque Nm max.	Weight g
36403.W0122	M 8	17.0	19.0	15	8	17	4	2.1	10	12
36403.W0133	M10	19.0	21.5	20	10	19	5	2.4	10	18
36403.W0143	M12	22.0	25.0	20	14	22	6	3.4	10	24
36403.W0021	M 8	12.5	19.4	10	10	17	-	2.8	18	15
36403.W0031	M10	14.5	21.9	10	12	19	-	3.8	2	21
36403.W0032	M10	14.5	21.9	15	12	19	-	3.8	32	33
36403.W0041	M12	17.5	25.2	10	14	22	-	5.5	60	30
36403.W0042	M12	17.5	25.2	15	14	22	-	5.5	60	46

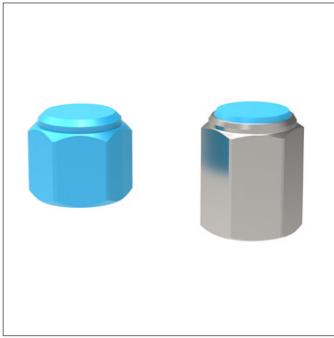

36404

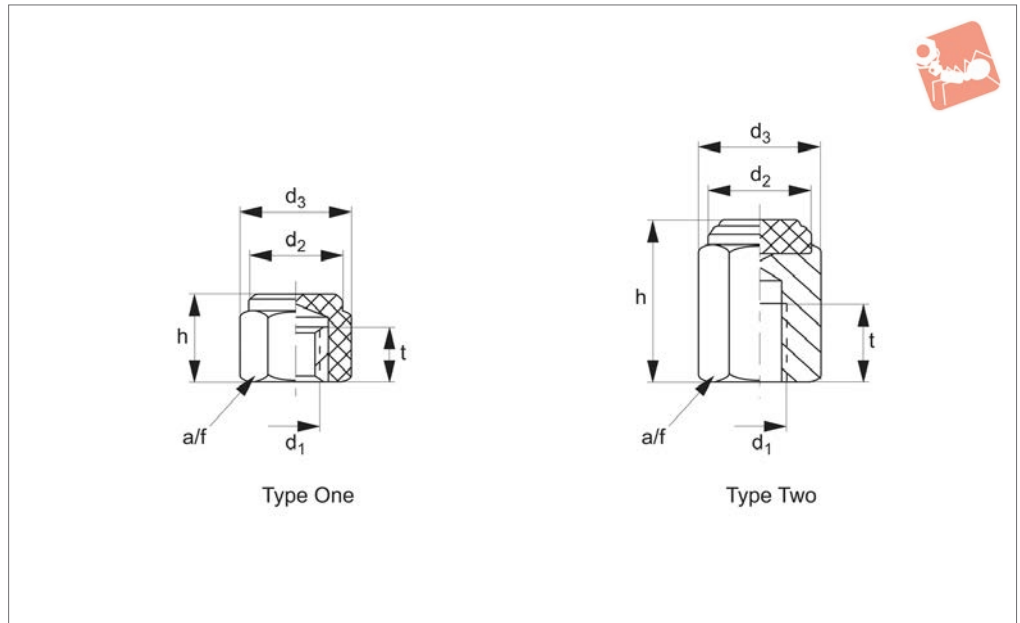

Material

Body: stainless steel 1.4305

Pad: plastic (PEEK), blue

Technical Notes

The buttons are used as seats, stops,

supports and thrust pads in jigs and fixtures as well as machine and equipment design.

Stated starting torque for female thread is based on use of bolt strength class 8 or

greater, and with full engagement of female thread.

Temperature range -60 to +250°C.

Tips

For male thread see 36403.

Order No.	Type	d ₁	d ₂	d ₃	h ₁ ±0.1	t ₁	A/F ₁	Static load kN	Tightening torque Nm max.	Weight g
36404.W0222	One	M 8	17.0	19.0	15	9	-	2.1	10	7
36404.W0233	One	M10	19.0	21.5	20	10	-	2.4	10	11
36404.W0243	One	M12	22.0	25.0	20	12	-	3.4	10	16
36404.W0324	Two	M 8	12.5	19.4	25	12	17	2.8	18	36
36404.W0335	Two	M10	14.5	21.9	30	15	19	3.8	32	54
36404.W0345	Two	M12	17.5	25.2	30	18	22	5.5	60	71



Locating Pins

pin shaped



Locating Pins

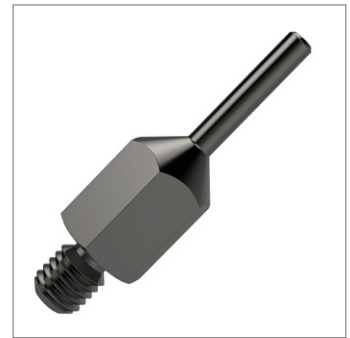
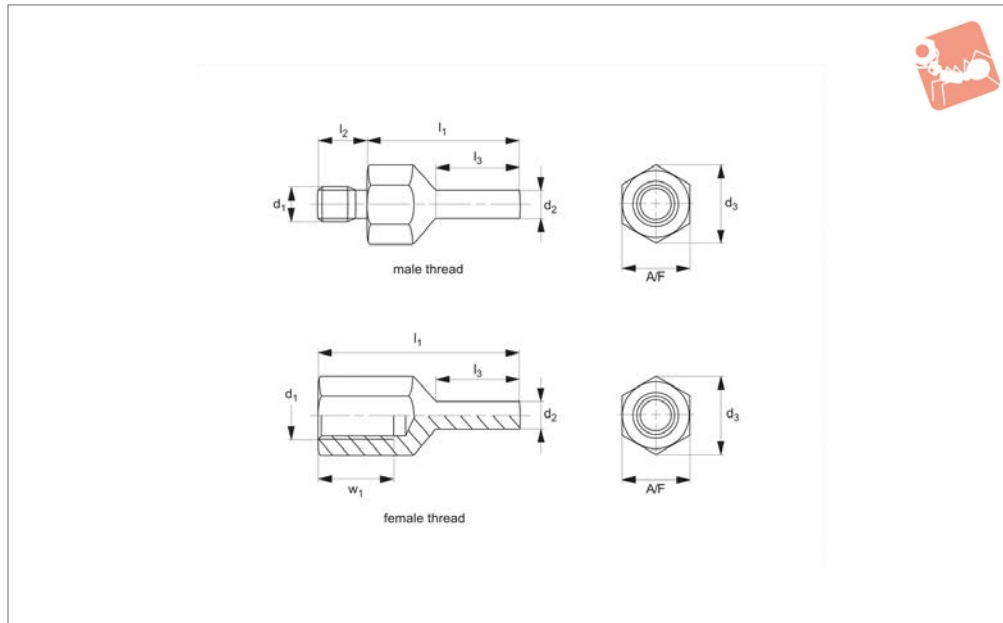

36440

LOCATING PINS

Material

Heat-treated steel, blackened. Surface induction hardened and ground.

Technical Notes

To be used as solid and precise seat and stop. The pin-shaped form of this locating

pin allows an application in components with narrow seating points.

Order No.	Finish	d ₁	l ₁ ±0.01	d ₂	l ₂	d ₃	l ₃	w ₁	A/F	Torque to Nm max.	Weight g
36440.W0402	Male Thread	M 6	20	4	8	11.0	10.0	-	10	7	8
36440.W0404	Male Thread	M 6	30	4	8	11.0	15.0	-	10	7	12
36440.W0412	Male Thread	M 8	30	4	10	14.4	15.0	-	13	18	17
36440.W0414	Male Thread	M 8	40	4	10	14.4	20.0	-	13	18	23
36440.W0416	Male Thread	M 8	30	6	10	14.4	15.0	-	13	18	20
36440.W0418	Male Thread	M 8	40	6	10	14.4	20.0	-	13	18	27
36440.W0422	Male Thread	M10	30	6	14	19.0	15.0	-	17	32	30
36440.W0424	Male Thread	M10	50	6	14	19.0	25.0	-	17	32	51
36440.W0426	Male Thread	M10	30	8	14	19.0	15.0	-	17	32	35
36440.W0428	Male Thread	M10	50	8	14	19.0	25.0	-	17	32	58
36440.W0432	Male Thread	M12	40	6	14	21.2	20.0	-	19	60	48
36440.W0434	Male Thread	M12	60	6	14	21.2	30.0	-	19	60	75
36440.W0436	Male Thread	M12	40	8	14	21.2	20.0	-	19	60	56
36440.W0438	Male Thread	M12	60	8	14	21.2	30.0	-	19	60	83
36440.W0452	Female Thread	M 6	20	4	-	11.0	8.5	6	10	7	6
36440.W0454	Female Thread	M 6	30	4	-	11.0	13.5	9	10	7	9
36440.W0462	Female Thread	M 8	30	4	-	14.4	13.0	10	13	18	13
36440.W0464	Female Thread	M 8	40	4	-	14.4	18.0	14	13	18	18
36440.W0466	Female Thread	M 8	30	6	-	14.4	13.0	10	13	18	16
36440.W0468	Female Thread	M 8	40	6	-	14.4	18.0	14	13	18	21
36440.W0472	Female Thread	M10	30	6	-	19.0	12.0	10	17	32	24
36440.W0474	Female Thread	M10	50	6	-	19.0	25.0	15	17	32	38
36440.W0476	Female Thread	M10	30	8	-	19.0	12.0	10	17	32	28
36440.W0478	Female Thread	M10	50	8	-	19.0	25.0	15	17	32	44
36440.W0482	Female Thread	M12	40	6	-	21.2	18.0	12	19	60	36
36440.W0484	Female Thread	M12	60	6	-	21.2	28.0	18	19	60	56
36440.W0486	Female Thread	M12	40	8	-	21.2	18.0	12	19	60	41
36440.W0488	Female Thread	M12	60	8	-	21.2	28.0	18	19	60	63

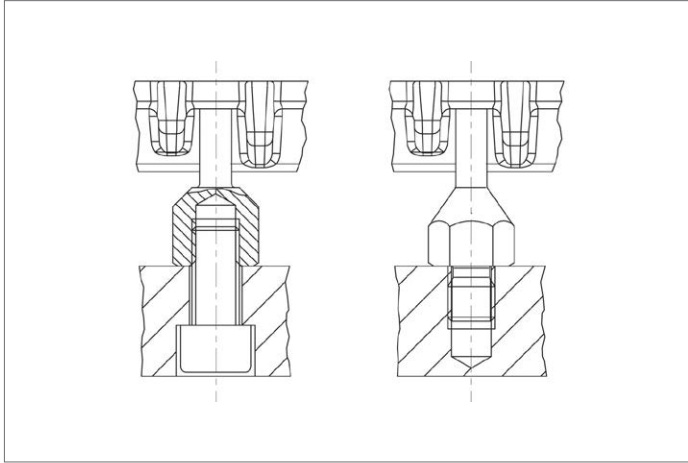



Gripper Pads - Carbide round

Grippers & Rest Pads

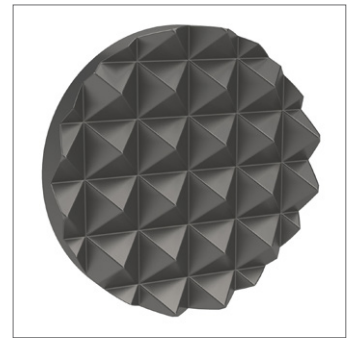
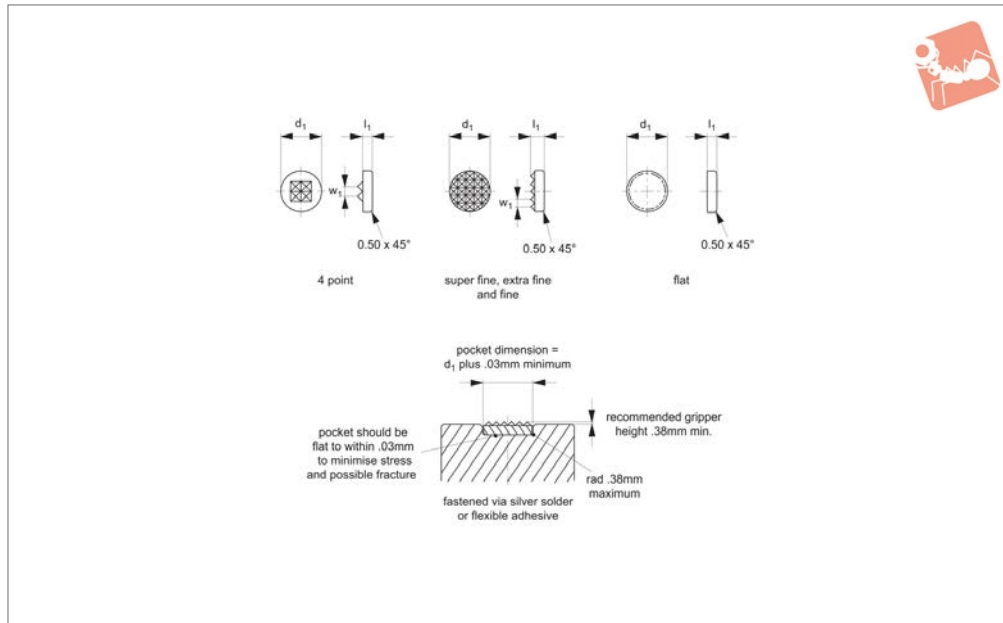

35300

GRIPPERS & REST PADS

Material

Solid carbide.

Technical Notes

Solid carbide pads are mounted into fixtures and press down on the surface of the clamped workpiece to give safe holding

without distortion. Carbide insert pads are especially suited for clamping cast and forged parts, as well as delicate workpieces such as pipes and tubes. Carbide insert pads can be built into clamps, stops and fixtures as well as chucks and vices.

Tips

Can be fastened via silver solder or a flexible adhesive. Note installation recommendations in technical diagram.

Order No.	Tooth pattern	d_1 +0.00 -0.13	l_1 +0.13 -0.00	w_1
35300.W0004	4 Point	7.9	3.2	3,9x90°
35300.W0008	4 Point	9.5	3.2	3,9x90°
35300.W0012	4 Point	11.1	3.2	3,9x90°
35300.W0015	4 Point	12.7	4.0	3,9x90°
35300.W0025	Super Fine	6.4	3.2	1,6x90°
35300.W0026	Super Fine	7.9	3.2	1,6x90°
35300.W0001	Extra Fine	6.4	3.2	2,4x90°
35300.W0003	Extra Fine	7.9	3.2	2,4x90°
35300.W0007	Extra Fine	9.5	3.2	2,4x90°
35300.W0011	Extra Fine	11.1	3.2	2,4x90°
35300.W0014	Extra Fine	12.7	3.2	2,4x90°
35300.W0018	Extra Fine	15.9	3.2	2,4x90°
35300.W0021	Extra Fine	19.1	3.2	2,4x90°
35300.W0023	Extra Fine	25.4	4.0	2,4x90°
35300.W0006	Fine	9.5	3.2	2,2x90°
35300.W0010	Fine	11.1	3.2	2,2x90°
35300.W0013	Fine	12.7	3.2	2,2x90°
35300.W0017	Fine	15.9	3.2	2,2x90°
35300.W0020	Fine	19.1	3.2	2,2x90°
35300.W0002	Flat	6.4	3.2	-
35300.W0005	Flat	7.9	3.2	-
35300.W0009	Flat	9.5	3.2	-
35300.W0016	Flat	12.7	3.2	-
35300.W0019	Flat	15.9	3.2	-
35300.W0022	Flat	19.1	3.2	-
35300.W0024	Flat	25.4	4.0	-

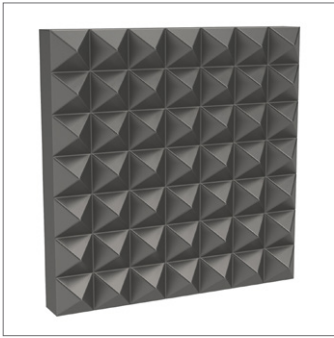

35310

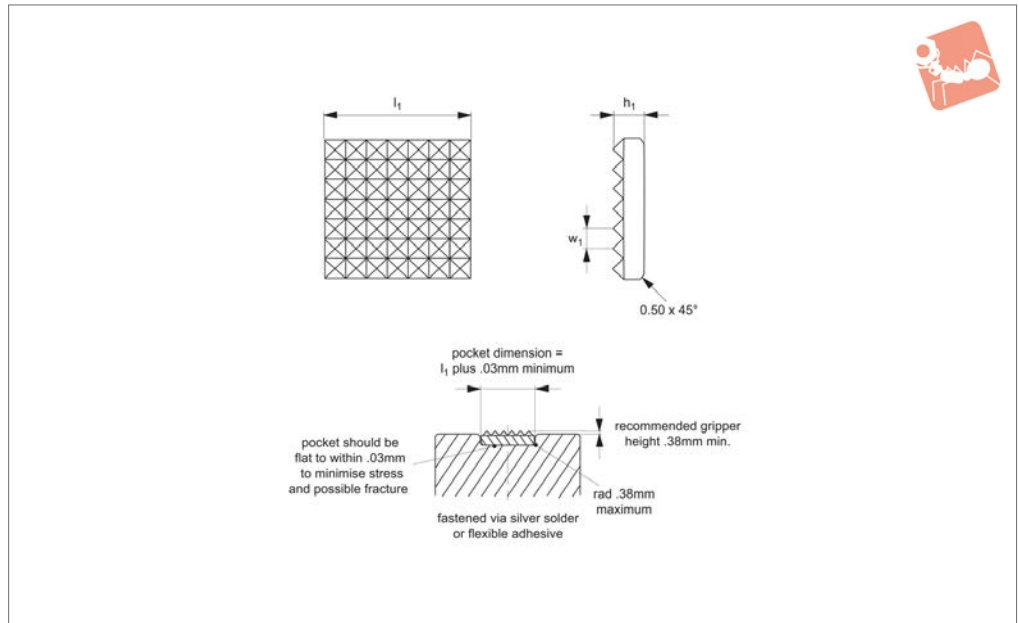

Material

Solid carbide.

Technical Notes

Solid carbide pads are mounted into fixtures and press down on the surface of the clamped workpiece to give safe holding

without distortion. Carbide insert pads are especially suited for clamping cast and forged parts, as well as delicate workpieces such as pipes and tubes. Carbide insert pads can be built into clamps, stops and fixtures as well as chucks and vices.

Tips

Can be fastened via silver solder or a flexible adhesive. Note installation recommendations in technical diagram.

Order No.	Tooth pattern	l_1 +0.00 -0.13	w_1	h_1 +0.13 -0.00
35310.W0000	Fine	9.5	3,2x90°	3.2
35310.W0001	Fine	12.7	3,2x90°	3.2
35310.W0002	Extra Fine	12.7	2,4x90°	3.2
35310.W0003	Extra Fine	15.9	2,4x90°	3.2
35310.W0004	Extra Fine	19.1	2,4x90°	4.0
35310.W0005	Extra Fine	25.4	2,4x90°	4.0
35310.W0006	Extra Fine	9.5	2,4x90°	3.2

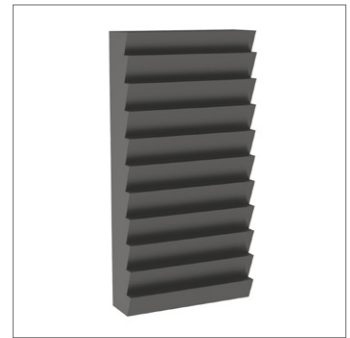
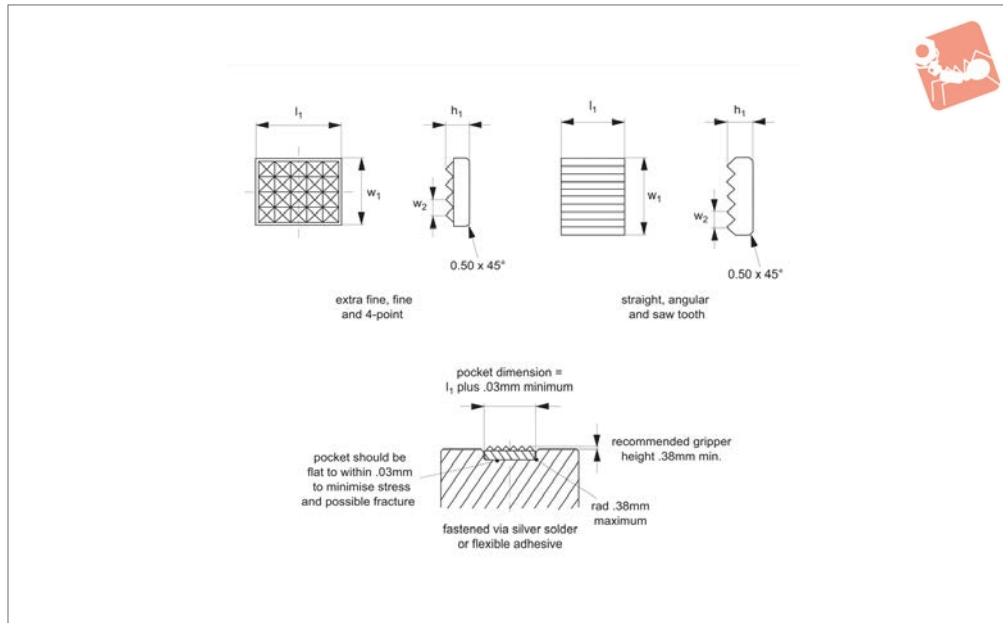

35320

GRIPPERS & REST PADS

Material

Solid carbide.

Technical Notes

Solid carbide pads are mounted into fixtures and press down on the surface of the clamped workpiece to give safe holding

without distortion. Carbide insert pads are especially suited for clamping cast and forged parts, as well as delicate workpieces such as pipes and tubes. Carbide insert pads can be built into clamps, stops and fixtures as well as chucks and vices.

Tips

Can be fastened via silver solder or a flexible adhesive. Note installation recommendations in technical diagram.

Order No.	Tooth pattern	l_1 +0.00 -0.13	w_1 +0.00 -0.13	w_2	h_1 +0.13 -0.00
35320.W0001	Extra Fine	9.5	6.4	2,4x90°	3.2
35320.W0003	Extra Fine	12.7	10.3	2,4x90°	3.2
35320.W0008	Extra Fine	25.4	12.7	2,4x90°	4.8
35320.W0002	Fine	12.7	10.3	3,2x90°	3.2
35320.W0005	Fine	11.5	10.3	3,2x90°	3.2
35320.W0004	4 Point	11.5	10.3	3,9x90°	3.2
35320.W0006	Straight	11.5	10.3	2,9x90°	3.2
35320.W0007	Angular	11.5	10.3	2,9x90°	3.2
35320.W0009	Saw Tooth	25.4	12.7	-	4.8
35320.W0010	Saw Tooth	38.1	19.1	-	6.4



Grippers enhance workholding for multiple machining operations.

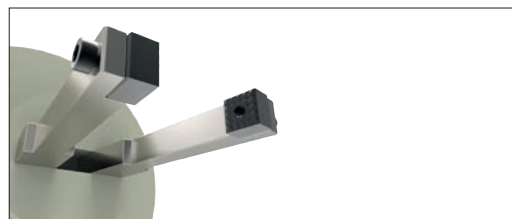

Grippers increase handling capability.

Pads and Gripper Options

Pads

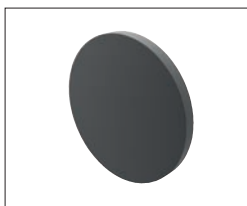

Solid Carbide
High impact carbide pads, can be brazed or bonded into place.



Carbide Tipped
Constructed with high impact carbide pad brazed to a heat treated alloy steel body. Mount via tapped hole or a flat on the outside diameter for set screw mounting.



Hardened Steel
Made from 8620 steel, carburized and hardened to Rc 58/60 1.2mm with black oxide finish. Mount via tapped or counter bored hole.



Non-marking Thermoplast
Made from white thermoplast. Mount via tapped or counter bored hole.



Stainless Steel
Pad from 17-4 stainless steel, hardened to Rc 43/46. Mount via tapped or counter bored hole.



Abrasive Diamond Surface
Abrasive surface permanently fused to a 17-4 stainless steel pad, hardened to Rc 43/46. The surface texture is comparable to a 100 grit abrasive. Mount via tapped or counter bored hole.



Soft Urethane Surface
Urethane surface is permanently bonded to a 300 series stainless steel pad. The urethane provides excellent protection against damage on delicate work surfaces. Tapped hole mounting.

see our website for our full range:
wixroyd.com

Grippers



High Speed Tool Steel
Manufactured from M-2 high speed tool steel, hardened to Rc 60/62 with black oxide finish. Mount via tapped hole, counter bored hole or a flat on the outside diameter for set screw mounting.

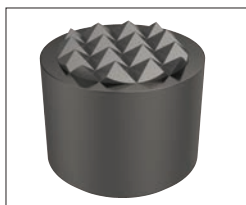

Carbide Tipped
Constructed with high impact carbide pad brazed to a heat treated alloy steel body. Mounts via tapped hole or a flat on the outside diameter for set screw mounting.

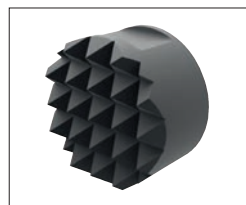

Solid Carbide
Manufactured from high impact carbide in a solid gripper pad or as a solid gripper body with a threaded brazed-in steel insert. Mount via tapped hole or a flat on the outside diameter for set screw mounting.

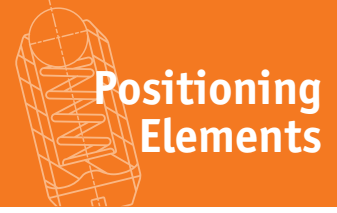
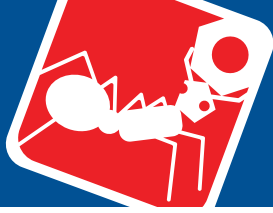

Tooth Pattern Specifications

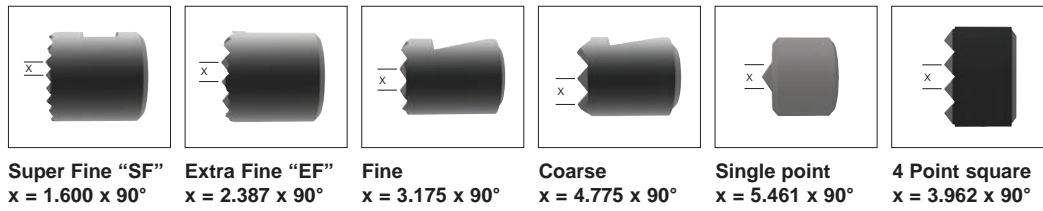
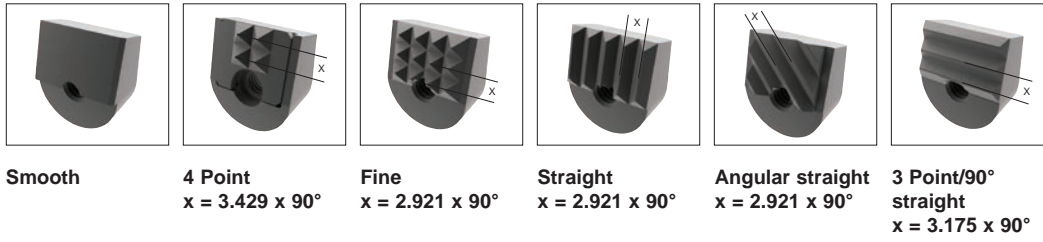

Mounting options

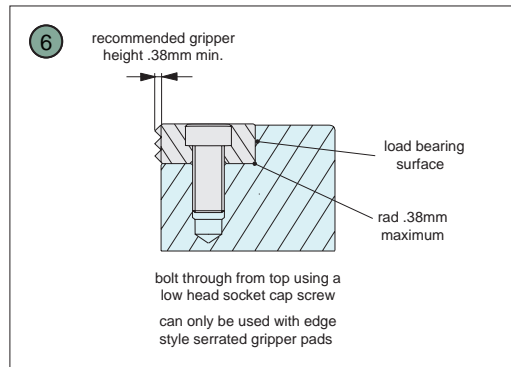
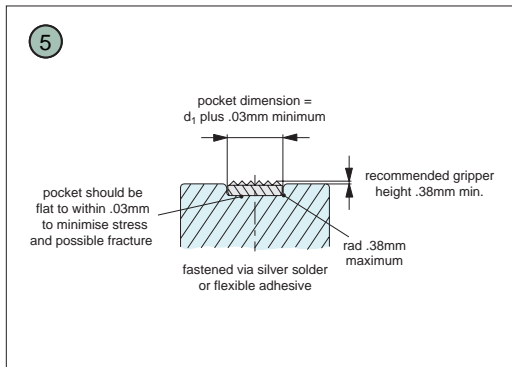
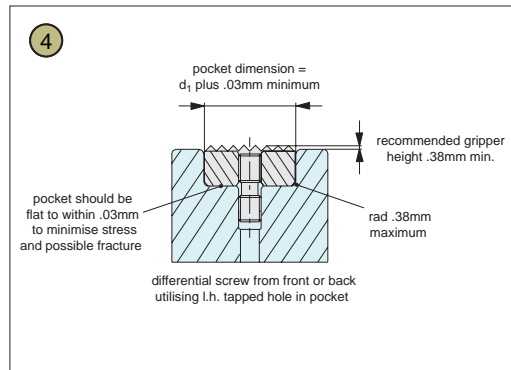
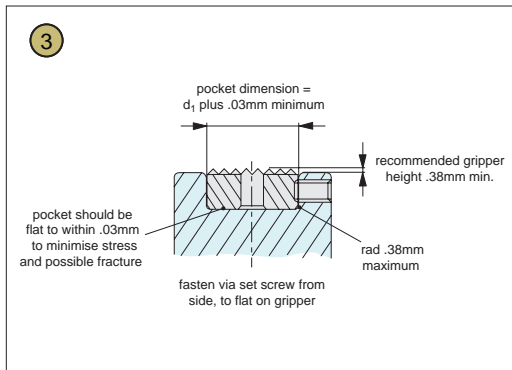
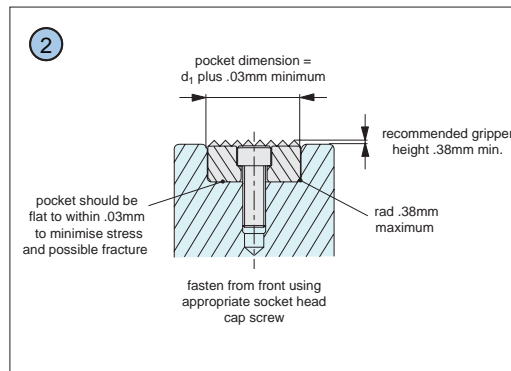
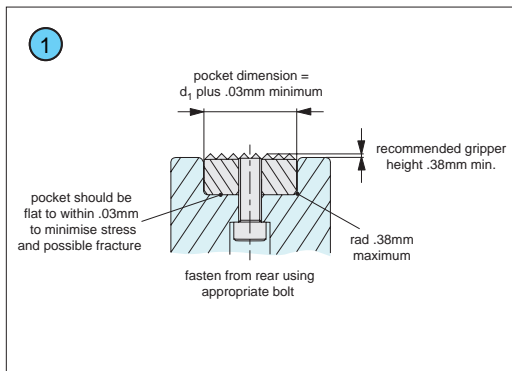

Angular Grippers

Our carbide and hardened steel grippers are available with a variety of tooth patterns, as specified on the product data tables.

Round/Square Grippers

Mounting Options for Carbide and Hardened Steel Grippers and Inserts.

Our carbide grippers and inserts can be installed in a number of different ways, the most suitable mounting method depends upon the specific insert – please refer to the product data table for specific information.

- 1 Round or square grippers and rest pads with tapped blind-hole or through hole tap.
- 2 Round or square grippers and rest pads with counter-bored hole.
- 3 Round grippers with flat on the O.D. for set screw mounting. Also square gripper mounting.
- 4 Round or square grippers with through tapped hole.
- 5 Round or square carbide pads.
- 6 Counter-bored edge grippers.



A Range of Specialist Gripping Pads to Suit Your Application

Urethane Coated



Unique urethane coat prevents marking of delicate components during machining or manipulation by robots. The urethane pad is permanently bonded to the stainless steel body of the gripping pad. With a bubbled texture, air is able to escape and hence avoid any suction action - enabling easy releasing of parts.

These are available in three different urethane durometers.



35 durometer:
Pencil rubber top



60 durometer:
Car tyre



80 durometer:
Skateboard wheel

Abrasive Diamond Coated

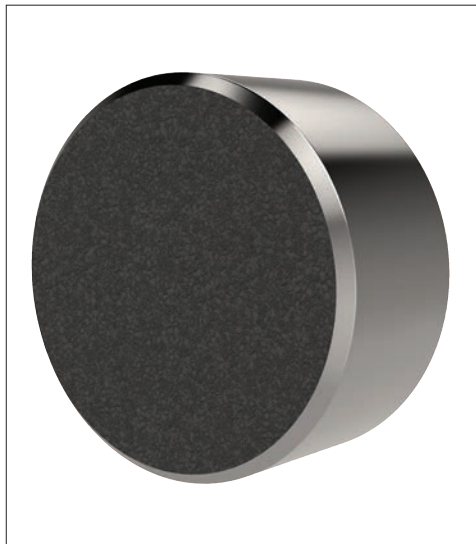

To improve handling of smooth or slippery components, with a minimum of clamping pressure, our abrasive diamond coated pads provide an excellent solution.

Diamond powders are permanently fused to a 17-4 stainless pad, to provide an abrasive surface comparable to 100 grit value.



Sandpaper of 100 grit texture

Stainless Pads



Pads of 17-4 Stainless, hardened to RC 43/46 provide solutions to applications where material selection is of greater importance; for example nuclear or food processing or pharmaceutical applications.



Grippers - Carbide Tipped

steel body - round - rear fixing

Grippers & Rest Pads

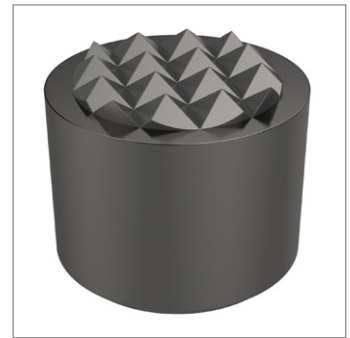
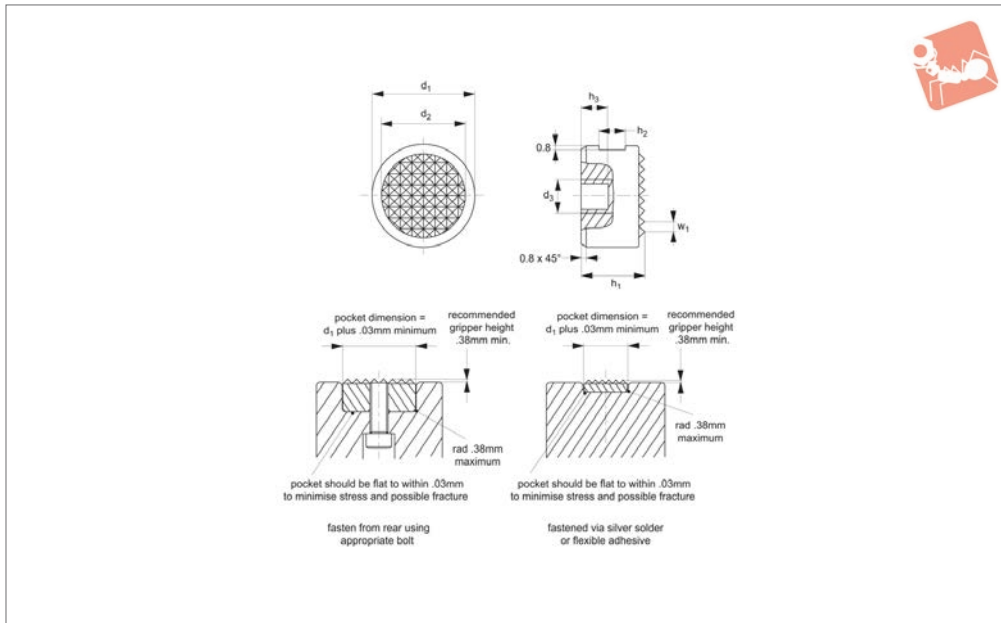

35330

GRIPPERS & REST PADS

Material

Solid carbide tipped grippers, in steel body.

to give safe holding without distortion. Especially suitable in chucks, vices and robotic grippers for extra grip.

appropriate bolt of thread d_2 . Note installation recommendations in technical diagram.

Technical Notes

These carbide tipped gripping pads press down onto the surface of the components

Tips

Can be fastened via use of set screw from side to flat on gripper, or from rear using

Order No.	Tooth pattern	d_1 +0.00 -0.13	h_1 +0.00 -0.13	h_2	h_3	d_2	d_3	w_1
35330.W0001	Extra Fine	10	10	4.5	4.8	7.9	M 5x0,8	2,4x90°
35330.W0002	Extra Fine	10	12	6.0	4.8	7.9	M 5x0,8	2,4x90°
35330.W0003	Fine	12	10	4.5	4.8	9.5	M 5x0,8	3,2x90°
35330.W0004	Fine	12	12	6.0	4.8	9.5	M 5x0,8	3,2x90°
35330.W0005	Fine	16	10	4.5	4.8	12.7	M 6x1,0	3,2x90°
35330.W0006	Fine	16	12	6.0	4.8	12.7	M 6x1,0	3,2x90°
35330.W0007	Fine	20	10	4.5	4.8	15.9	M 6x1,0	3,2x90°
35330.W0008	Fine	20	12	6.0	4.8	15.9	M 6x1,0	3,2x90°
35330.W0009	Fine	25	10	4.5	4.8	19.1	M 6x1,0	3,2x90°
35330.W0010	Fine	25	12	6.0	4.8	19.1	M 6x1,0	3,2x90°

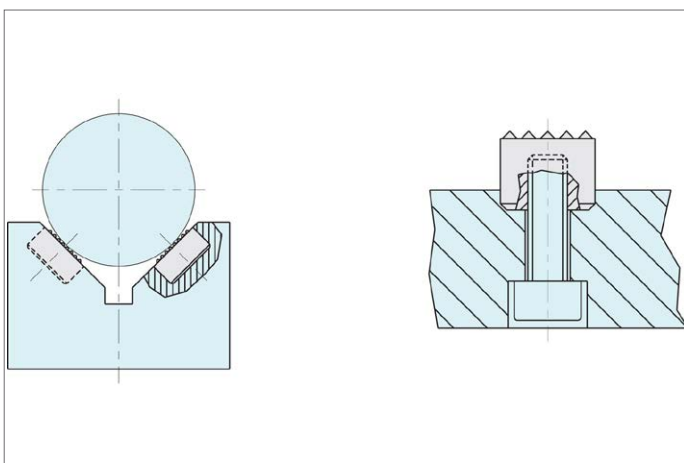

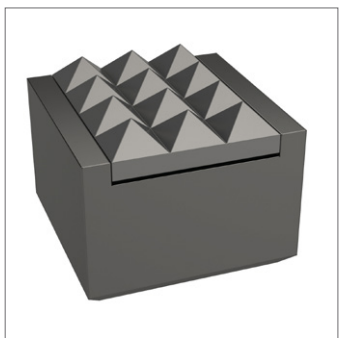

35340

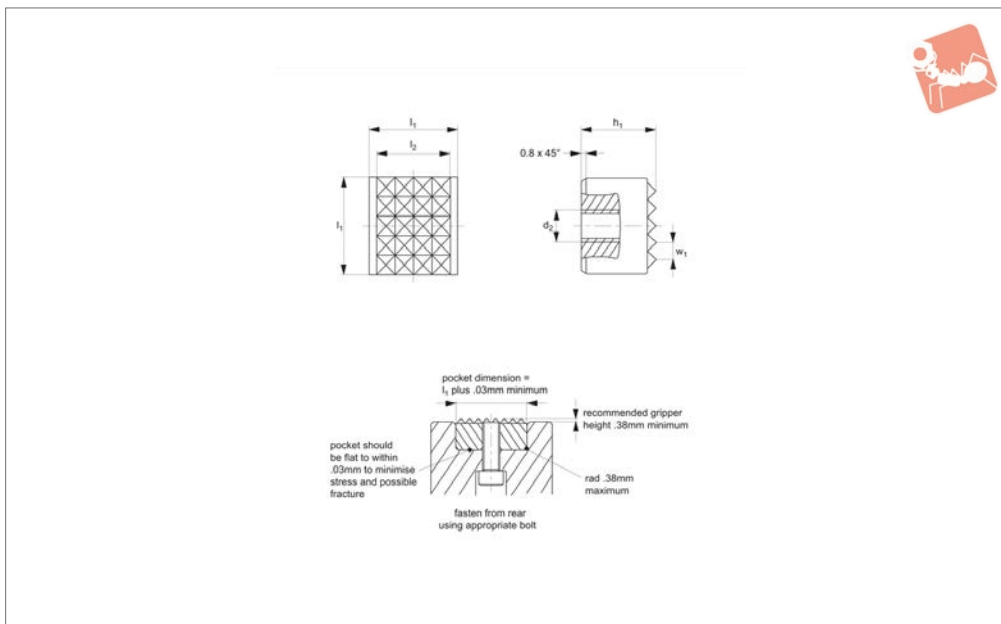

Material

Solid carbide tipped grippers, in steel body.

Technical Notes

These carbide tipped gripping pads press

down onto the surface of the component to give safe holding without distortion. Especially suitable in chucks, vices and robotic grippers for extra grip.

Tips

Can be fastened from rear using appropriate bolt. Note installation recommendations in technical diagram.

Order No.	Tooth pattern	l_1	l_2	h_1	d_2	w_1
35340.W0001	Fine	12.0	10.32	10.00	M 5x0,8	3,175x90°
35340.W0002	Fine	12.0	10.32	12.00	M 5x0,8	3,175x90°
35340.W0003	Ex-fine	12.7	10.32	9.53	M 6x1,0	2,387x90°



Grippers - Carbide Tipped steel body - angled - rear fixing

Grippers & Rest Pads

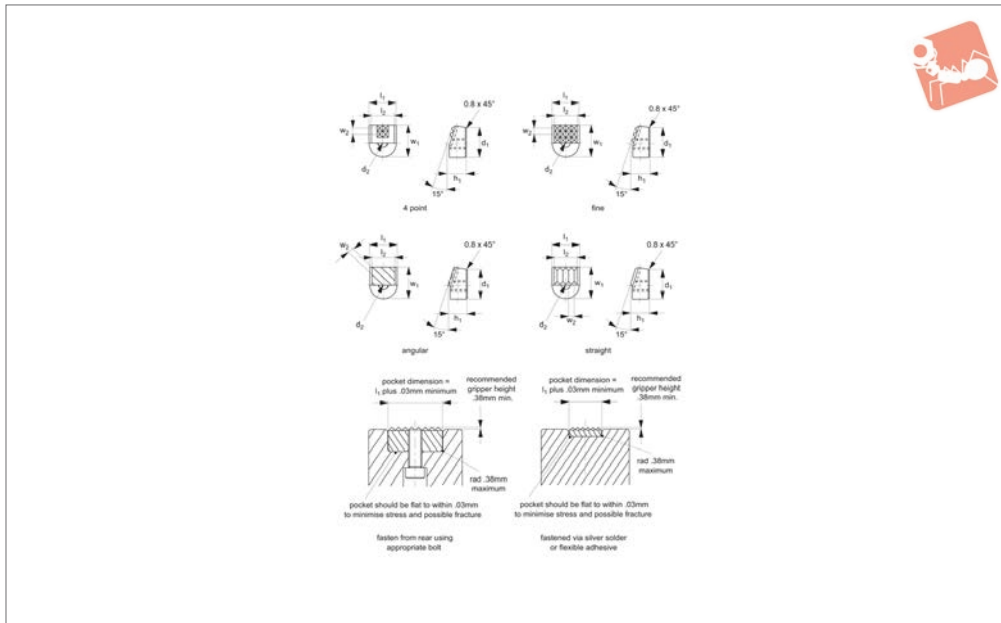

35350

GRIPPERS & REST PADS

Material

Steel, heat-treated with brazed on carbide pad.

Technical Notes

Also available with imperial threads on

request. These angle gripper inserts press down on the surface of the clamped work-piece to give safe holding without distortion. They can be built into clamps, stops and fixtures, as well as chucks, vices and

robotic grippers for extra grip.

Tips

Can be fastened from rear using appropriate bolt. Note installation recommendations in technical diagram.

Order No.	Tooth pattern	d ₁	l ₁ +0.000 -0.002	l ₂	h ₁ +0.000 -0.005	d ₂	w ₁ +0.000 -0.010	w ₂
35350.W0001	4 Point	15	14.29	11.9	9.5	M 5x0,8	16.5	3,4x90°
35350.W0002	Fine	15	14.29	11.9	9.5	M 5x0,8	16.5	2,9x90°
35350.W0003	Straight	15	14.29	11.9	9.5	M 5x0,8	16.5	2,9x90°
35350.W0004	Angular	15	14.29	11.9	9.5	M 5x0,8	16.5	2,9x90°



35400

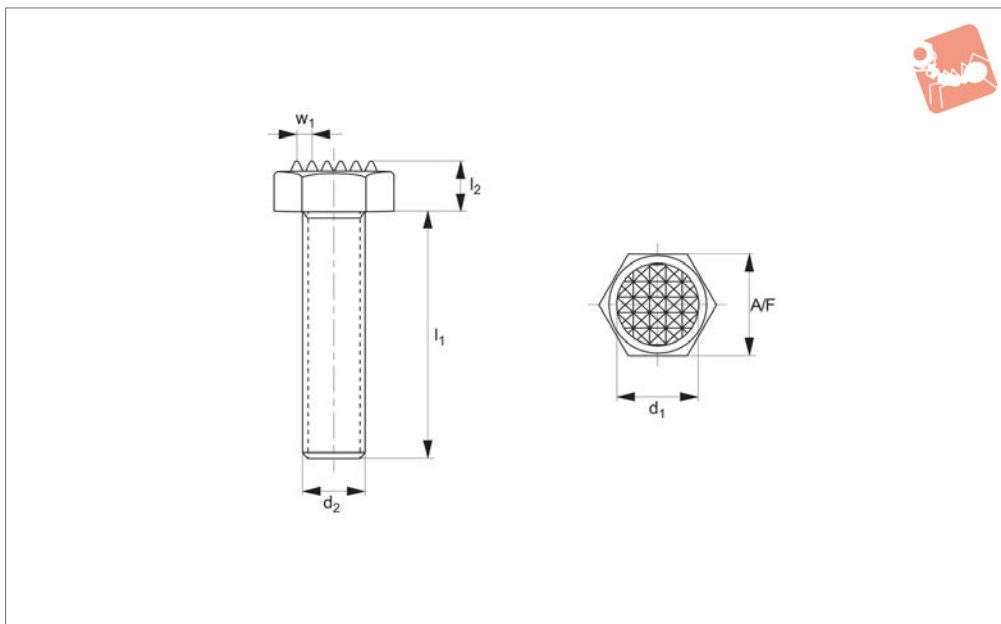

Material

Hex headed steel bolt with solid carbide tipped insert.

Technical Notes

Adjustable carbide tipped grippers are

used in jigs and fixtures, modular fixtures and tooling. They are especially suitable for holding castings and other components. Adjustment can be made within the thread length. Use a DIN 439B

hex. nut for adjustment and securing.

Order No.	Tooth pattern	d ₁	l ₁	l ₂	d ₂	w ₁	A/F
35400.W0001	Ex-fine	7.94	12	5.0	M 6x1,00	2,387x90°	10
35400.W0002	Ex-fine	7.94	25	5.0	M 6x1,00	2,387x90°	10
35400.W0003	Fine	9.53	12	6.4	M 8x1,25	3,175x90°	13
35400.W0004	Fine	9.53	25	6.4	M 8x1,25	3,175x90°	13
35400.W0005	Fine	9.53	35	6.4	M 8x1,25	3,175x90°	13
35400.W0006	Fine	12.70	12	7.5	M10x1,50	3,175x90°	17
35400.W0007	Fine	12.70	25	7.5	M10x1,50	3,175x90°	17
35400.W0008	Fine	12.70	40	7.5	M10x1,50	3,175x90°	17
35400.W0009	Fine	15.88	25	8.7	M12x1,75	3,175x90°	19
35400.W0010	Fine	15.88	40	8.7	M12x1,75	3,175x90°	19
35400.W0011	Fine	19.05	35	11.0	M16x2,00	3,175x90°	24
35400.W0012	Fine	19.05	50	11.0	M16x2,00	3,175x90°	24
35400.W0013	Ex-fine	25.40	40	13.7	M20x2,50	2,387x90°	30
35400.W0014	Ex-fine	25.40	60	13.7	M20x2,50	2,387x90°	30

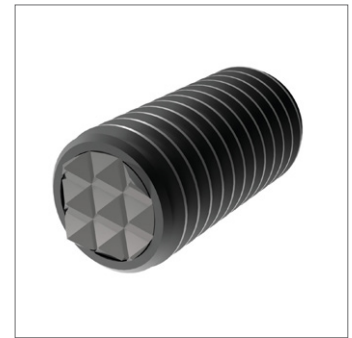
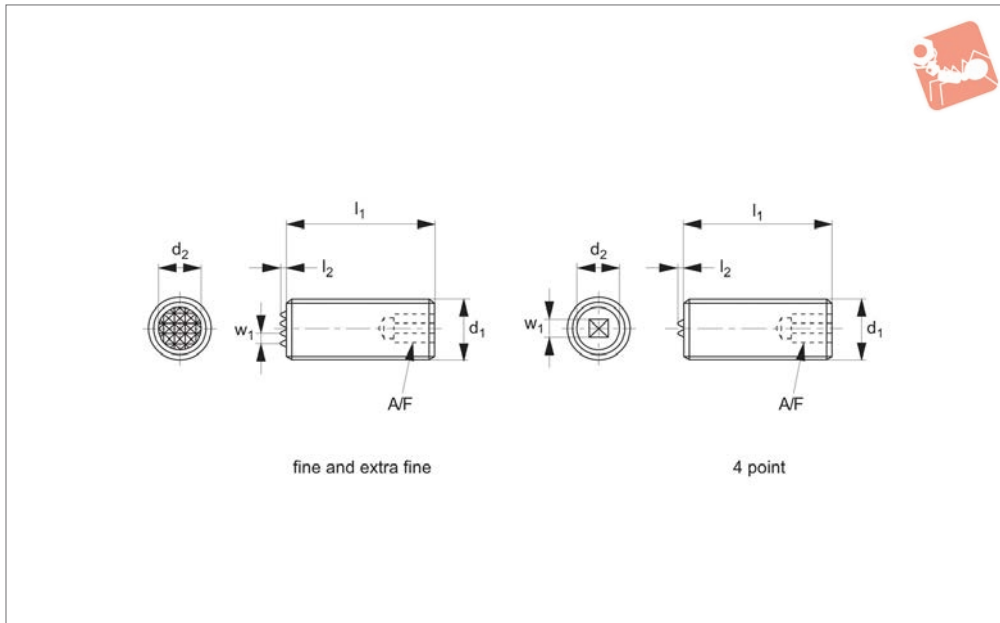

35410

GRIPPERS & REST PADS

Material

Steel set screw with hex socket and solid carbide tipped insert.

used in jigs and fixtures, modular fixtures and tooling. They are especially suitable for holding castings and other components. Adjustment can be made by using the hex key in socket, and can be

adjusted within the thread length. Use a DIN 439B hex nut for adjustment and securing.

Technical Notes

Adjustable carbide tipped grippers are

Order No.	Tooth pattern	d ₁	l ₁	l ₂	d ₂	w ₁	A/F
35410.W0001	Extra Fine	M10x1,5	25	1.3	6.4	2,4x90°	5
35410.W0002	Extra Fine	M10x1,5	50	1.3	6.4	2,4x90°	5
35410.W0004	Extra Fine	M12x1,75	25	1.3	7.9	2,4x90°	6
35410.W0006	Extra Fine	M12x1,75	50	1.3	7.9	2,4x90°	6
35410.W0014	Extra Fine	M20x2,5	50	1.3	12.7	2,4x90°	10
35410.W0008	Fine	M16x2,0	25	1.3	11.1	3,2x90°	8
35410.W0010	Fine	M16x2,0	50	1.3	11.1	3,2x90°	8
35410.W0012	Fine	M20x2,5	25	1.3	12.7	3,2x90°	10
35410.W0003	4 Point	M12x1,75	25	1.3	7.9	3,9x90°	6
35410.W0005	4 Point	M12x1,75	50	1.3	7.9	3,9x90°	6
35410.W0007	4 Point	M16x2,0	25	1.3	11.1	3,9x90°	8
35410.W0009	4 Point	M16x2,0	50	1.3	11.1	3,9x90°	8
35410.W0011	4 Point	M20x2,5	25	1.3	12.7	3,9x90°	10
35410.W0013	4 Point	M20x2,5	50	1.3	12.7	3,9x90°	10



35440

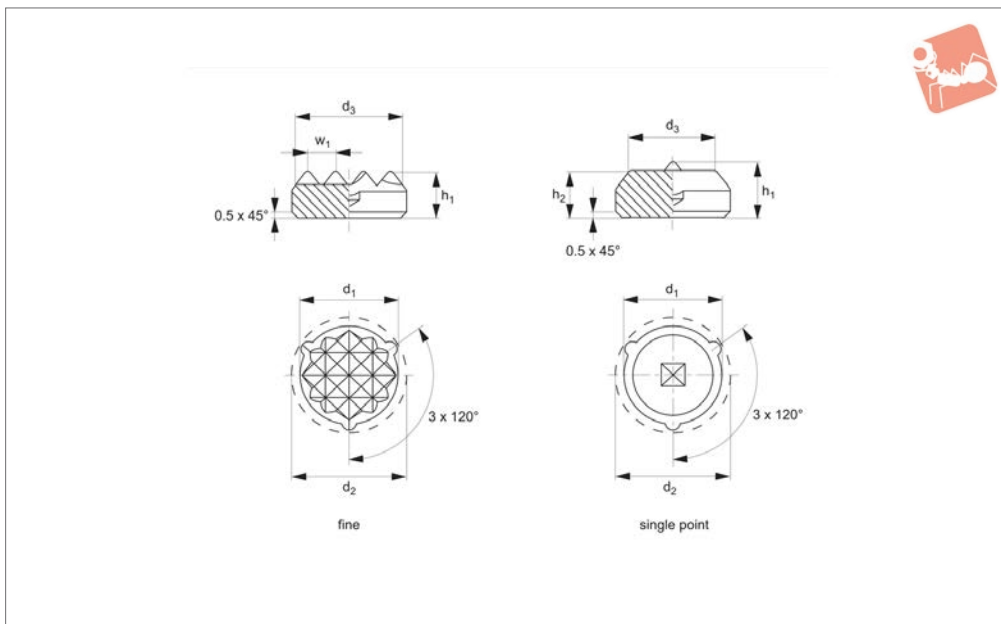

Material

Hard metal ribbed, hard metal pointed, 60 HRc.

Technical Notes

d_1 - for use when press-fitting into softer

metals such as aluminium. The three protrusions ensure centering of insert. d_2 - for use when gluing or soldering in place.

Tips

Can be integrated into fixtures, clamping jaws etc., to provide an abrasion-proof transmission of high holding forces on cast or forged workpieces.

Order No.	Tooth pattern	d_1 ± 0.1	h_1	h_2	d_2 ± 0.2	d_3 \approx	w_1	Weight g
35440.W0608	Fine	8.3	5.0	-	9.1	7.7	2	3
35440.W0611	Fine	11.3	5.0	-	12.1	10.6	2	6
35440.W0613	Fine	12.6	5.0	-	13.4	11.9	3	7
35440.W0615	Fine	16,6 ^{± 1.5}	5.0	-	17.4	16.0	3	12
35440.W0617	Fine	21,6 ^{± 1.5}	5.0	-	22.4	21.0	3	20
35440.W0628	Single Point	8.3	5.8	5	9.1	6.3	-	3
35440.W0631	Single Point	11.3	5.8	5	12.1	9.3	-	7
35440.W0633	Single Point	12.6	5.8	5	13.4	10.0	-	8



Grippers - Hard Tool Steel

round - screw fixing

Grippers & Rest Pads

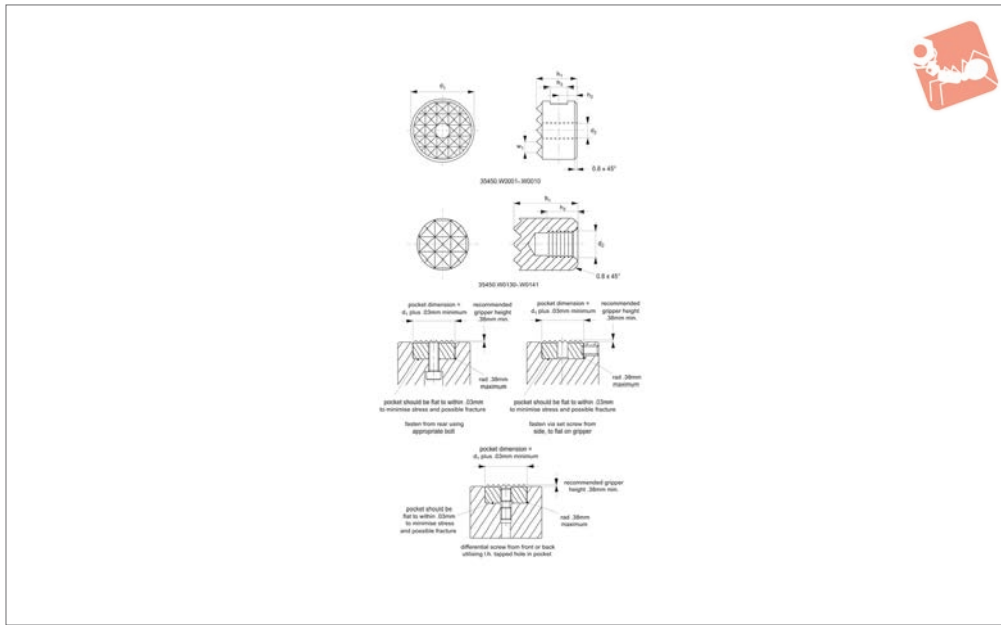

35450

GRIPPERS & REST PADS

Material

M2 tungsten-molybdenum high-speed steel, hardened to HRC 60-62.

Technical Notes

These hardened steel gripping pads press down on to the surface of the clamped

workpiece for safe holding without distortion. They are especially suitable where high load or clamping force is applied. Can be built into clamps, stops and fixtures as well as chucks, vices and robotic grippers for extra grip. M3 to M4 blind hole tapped.

Tips

Can be fastened via use of set screw or from rear using appropriate screw (thread d_2). Note installation recommendations in technical diagram.

Order No.	Tooth pattern	d_1 +0.00 -0.13	h_1 +0.00 -0.13	h_2	d_2	h_3	w_1
35450.W0001	Extra Fine	10	10	4.5	M 5x0,8	4.8	2,4x90°
35450.W0002	Extra Fine	10	12	6.0	M 5x0,8	4.8	2,4x90°
35450.W0003	Fine	12	10	4.5	M 5x0,8	4.8	3,2x90°
35450.W0004	Fine	12	12	6.0	M 5x0,8	4.8	3,2x90°
35450.W0005	Fine	16	10	4.5	M 6x1,0	4.8	3,2x90°
35450.W0006	Fine	16	12	6.0	M 6x1,0	4.8	3,2x90°
35450.W0007	Fine	20	10	4.5	M 6x1,0	4.8	3,2x90°
35450.W0008	Fine	20	12	6.0	M 6x1,0	4.8	3,2x90°
35450.W0009	Fine	25	10	4.5	M 6x1,0	4.8	3,2x90°
35450.W0010	Fine	25	12	6.0	M 6x1,0	4.8	3,2x90°
35450.W0130	Super Fine	6	10	5.0	M 3x0,5	-	1,6x90°
35450.W0131	Super Fine	6	12	7.0	M 3x0,5	-	1,6x90°
35450.W0140	Super Fine	8	10	5.0	M 4x0,7	-	1,6x90°
35450.W0141	Super Fine	8	12	7.0	M 4x0,7	-	1,6x90°

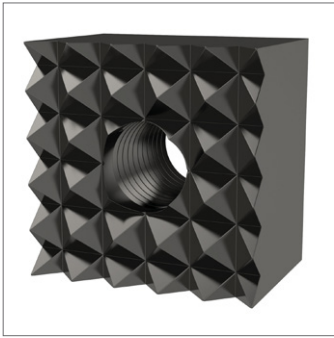

35460

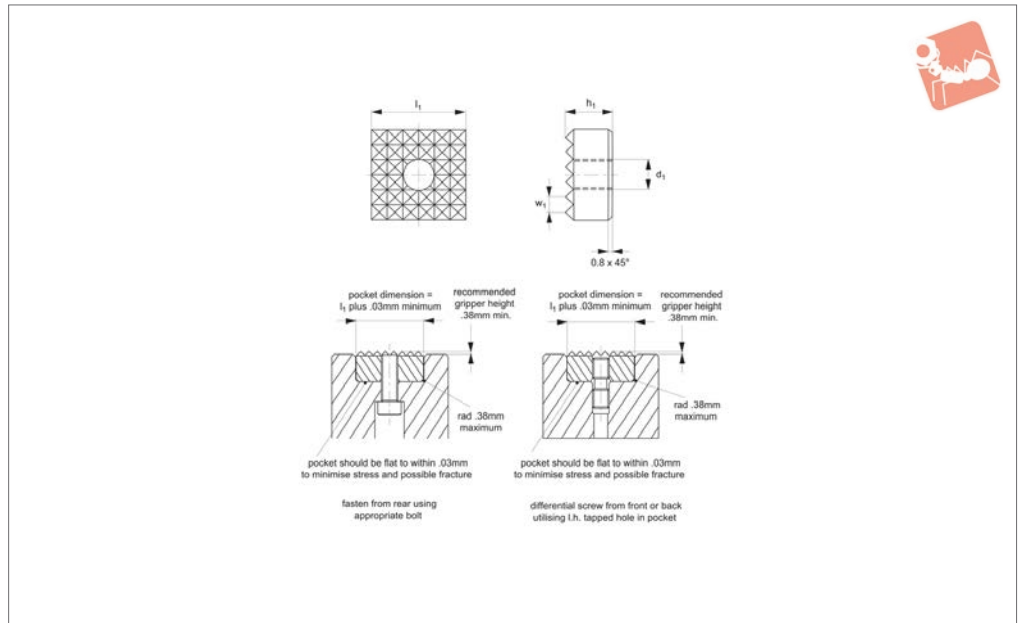

Material

M2 tungsten-molybdenum high-speed steel, hardened to HRc 60-62.

Technical Notes

These hardened steel gripping pads press down on to the surface of the clamped

workpiece for safe holding without distortion. They are especially suitable where high load or clamping force is applied. Can be built into clamps, stops and fixtures as well as chucks, vices and robotic grippers for extra grip.

Tips

Can be fastened via use of set screw or from rear using appropriate screw (thread d_2). Note installation recommendations in technical diagram.

Order No.	Tooth pattern	l_1 +0.00 -0.13	d_1	h_1 +0.00 -0.13	w_1
35460.W0001	Extra Fine	10	M 5x0,8	10	2,4x90°
35460.W0002	Extra Fine	10	M 5x0,8	12	2,4x90°
35460.W0003	Fine	12	M 5x0,8	10	3,2x90°
35460.W0004	Fine	12	M 5x0,8	12	3,2x90°
35460.W0005	Fine	20	M 5x0,8	10	3,2x90°
35460.W0006	Fine	20	M 5x0,8	12	3,2x90°
35460.W0007	Fine	25	M 6x1,0	10	3,2x90°
35460.W0008	Fine	25	M 6x1,0	12	3,2x90°
35460.W0161	Fine	16	M 6x1,0	10	3,2x90°
35460.W0162	Fine	16	M 6x1,0	12	3,2x90°



Grippers - Hard Tool Steel

round - front fixing

Grippers & Rest Pads

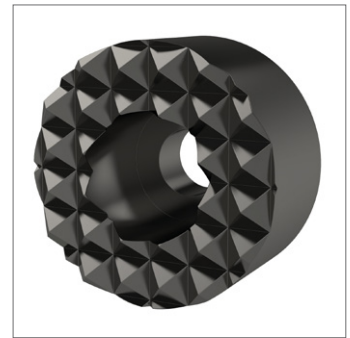
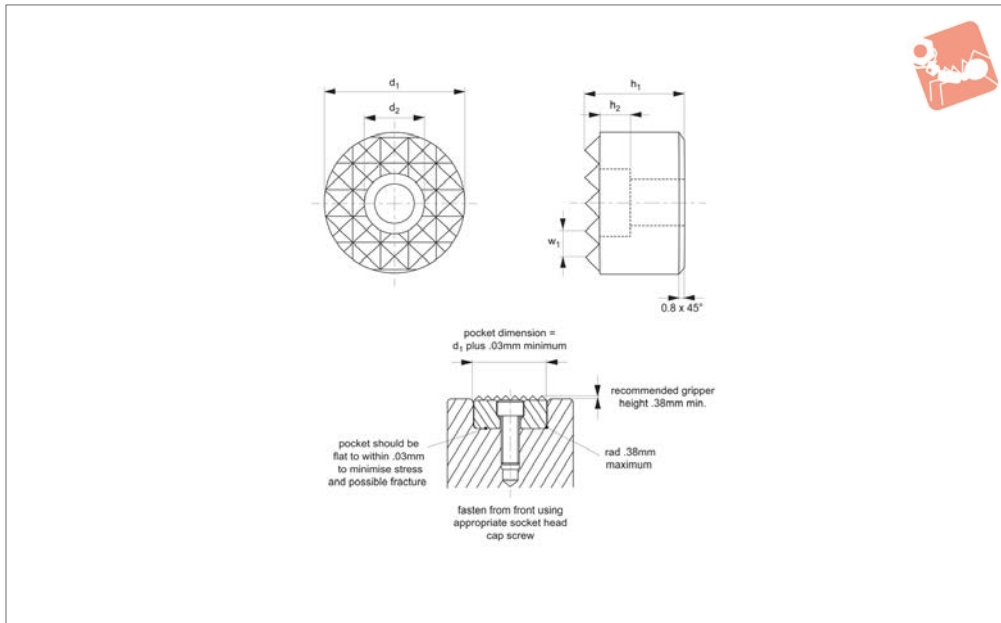

35480

GRIPPERS & REST PADS

Material

M2 tungsten-molybdenum high-speed steel, hardened to HRC 60-62.

Technical Notes

These hardened steel gripping pads press down onto the surface of the clamped

workpiece for safe holding without distortion. They are especially suitable where a high load or clamping force is applied. They can be built into clamps, stops and fixtures as well as chucks, vices and robotic grippers for extra grip.

Tips

Can be fastened from the front using a socket head cap screw. Note installation recommendations in technical diagram.

Order No.	Tooth pattern	d_1 +0.00 -0.13	h_1 +0.00 -0.13	h_2	d_2 to fit DIN 912	w_1
35480.W0001	Fine	12	10	5.6	M 4	3,2x90°
35480.W0002	Fine	12	12	5.6	M 4	3,2x90°
35480.W0003	Fine	16	10	5.6	M 4	3,2x90°
35480.W0004	Fine	16	12	5.6	M 4	3,2x90°
35480.W0005	Fine	20	10	6.6	M 5	3,2x90°
35480.W0006	Fine	20	12	6.6	M 5	3,2x90°
35480.W0007	Fine	25	10	7.6	M 6	3,2x90°
35480.W0008	Fine	25	12	7.6	M 6	3,2x90°



35490

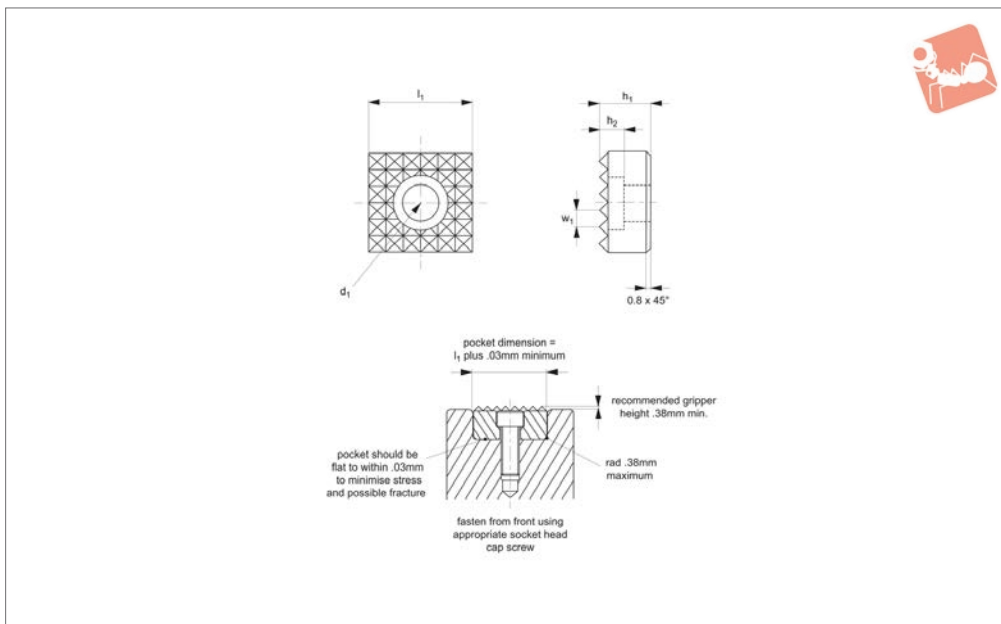

Material

M2 tungsten-molybdenum high-speed steel, hardened to HRC 60-62.

Technical Notes

These hardened steel gripping pads press down onto the surface of the clamped

workpiece for safe holding without distortion. They are especially suitable where a high load or clamping force is applied. They can be built into clamps, stops and fixtures as well as chucks, vices and robotic grippers for extra grip.

Tips

Can be fastened from the front using a socket head cap screw.

Note installation recommendations in technical diagram.

Order No.	Tooth pattern	l_1 +0.00 -0.13	d_1 to fit DIN 912	h_1 +0.00 -0.13	h_2	w_1
35490.W0001	Fine	12	M 4	10	5.6	3,2x90°
35490.W0002	Fine	12	M 4	12	5.6	3,2x90°
35490.W0003	Fine	20	M 5	10	6.6	3,2x90°
35490.W0004	Fine	20	M 5	12	6.6	3,2x90°
35490.W0005	Fine	25	M 6	10	7.6	3,2x90°
35490.W0006	Fine	25	M 6	12	7.6	3,2x90°
35490.W0161	Fine	16	M 4	10	5.6	3,2x90°
35490.W0162	Fine	16	M 4	12	5.6	3,2x90°

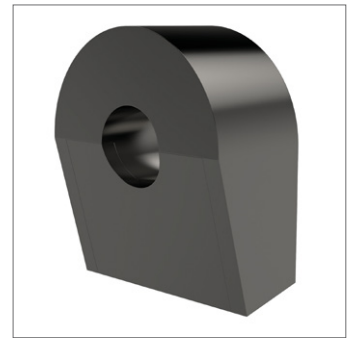
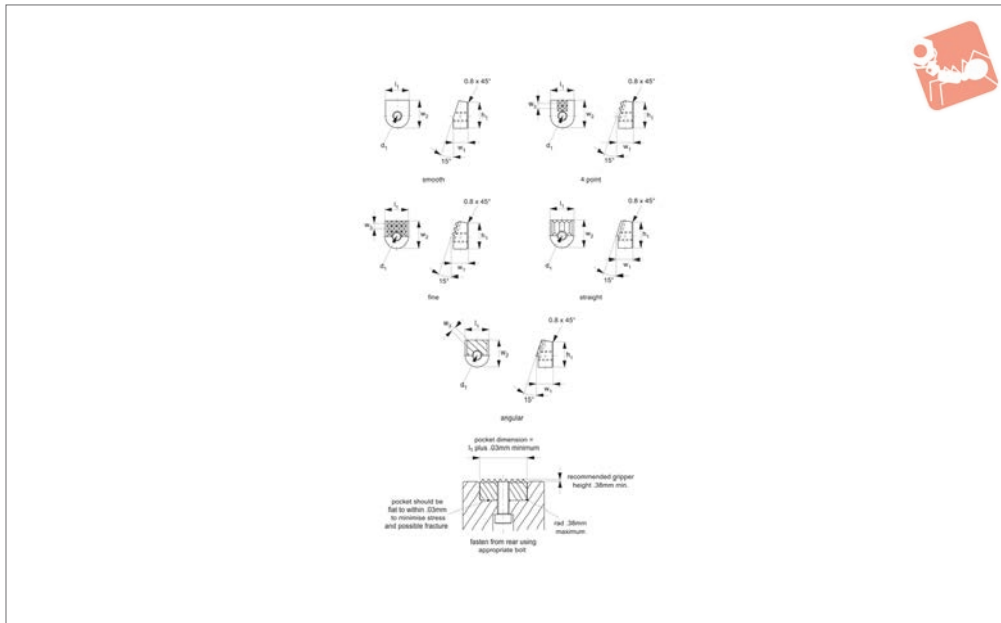

35500

GRIPPERS & REST PADS

Material

High-speed steel (M2), hardened to HRC 60-62.

Technical Notes

These angle gripper inserts press down onto the surface of the clamped workpiece

for safe holding without distortion. Especially suitable where a high load or clamping force is applied. They can be built into clamps, stops and fixtures as well as chucks, vices and robotic grippers for extra grip.

Tips

Can be fastened from rear using appropriate bolt. Note installation recommendations in technical diagram.

Order No.	Tooth pattern	l_1 +0.000 -0.002	d_1	h_1	w_1 +0.000 -0.005	w_2 +0.000 -0.005	w_3
35500.W0002	4 Point	14.3	M 5x0,8	15.2	9.5	16.5	3,4x90°
35500.W0009	4 Point	10.0	M 5x0,8	15.2	9.5	16.5	3,4x90°
35500.W0003	Fine	14.3	M 5x0,8	15.2	9.5	16.5	2,9x90°
35500.W0006	Straight	14.3	M 5x0,8	15.2	9.5	16.5	2,9x90°
35500.W0010	Straight	10.0	M 5x0,8	15.2	9.5	16.5	2,9x90°
35500.W0008	Smooth	10.0	M 5x0,8	15.2	9.5	16.5	-
35500.W0007	Angular	14.3	M 5x0,8	15.2	9.5	16.5	2,9x90°
35500.W0011	Angular	10.0	M 5x0,8	15.2	9.5	16.5	2,9x90°



35510

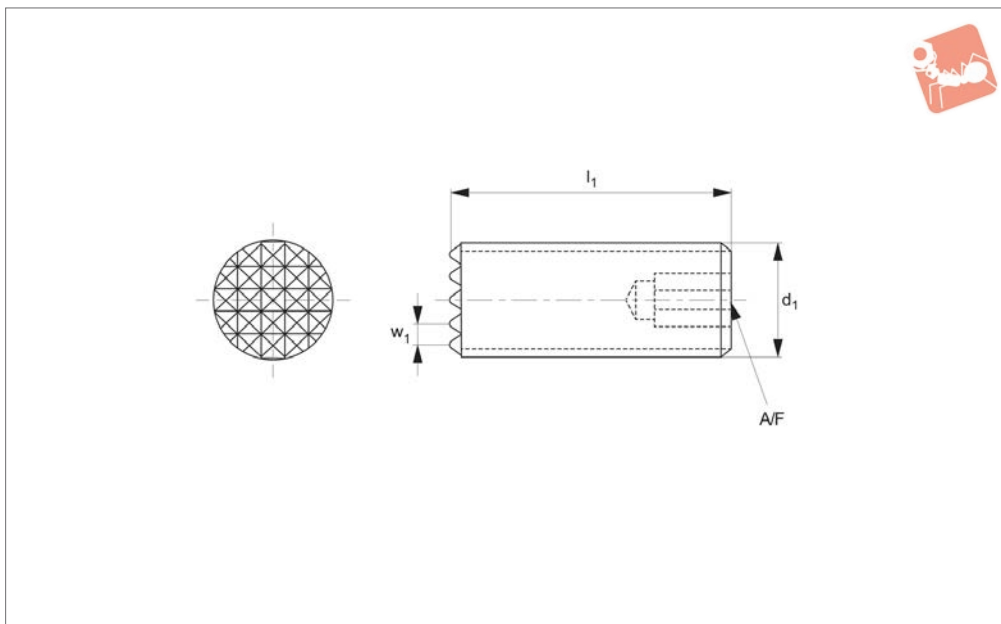

Material

Hardened tool steel to HRC 55-58, black oxide finish.

Technical Notes

These hardened tool steel gripping pads

press down on to the surface of the clamped workpiece for safe holding without distortion. They are especially suitable where high load or clamping force is applied. Can be built into clamps, stops

and fixtures as well as chucks, vices and robotic grippers for extra grip. Use a DIN 439B hex. nut for adjustment and securing.

Order No.	Tooth pattern	l_1	d_1	w_1	A/F
35510.W0001	Extra Fine	40	M10x1,50	2,4x90°	3
35510.W0002	Fine	25	M12x1,75	3,2x90°	5
35510.W0003	Fine	40	M12x1,75	3,2x90°	5
35510.W0004	Fine	40	M16x2,00	3,2x90°	6
35510.W0005	Fine	40	M20x2,50	3,2x90°	8



Grippers - Hard Tool Steel

edge gripper - front fixing

Grippers & Rest Pads

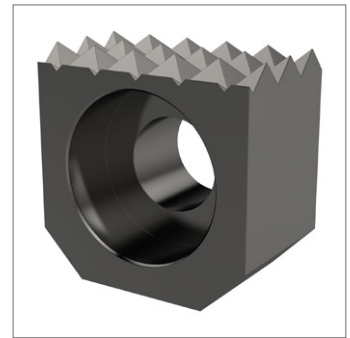

35520

GRIPPERS & REST PADS

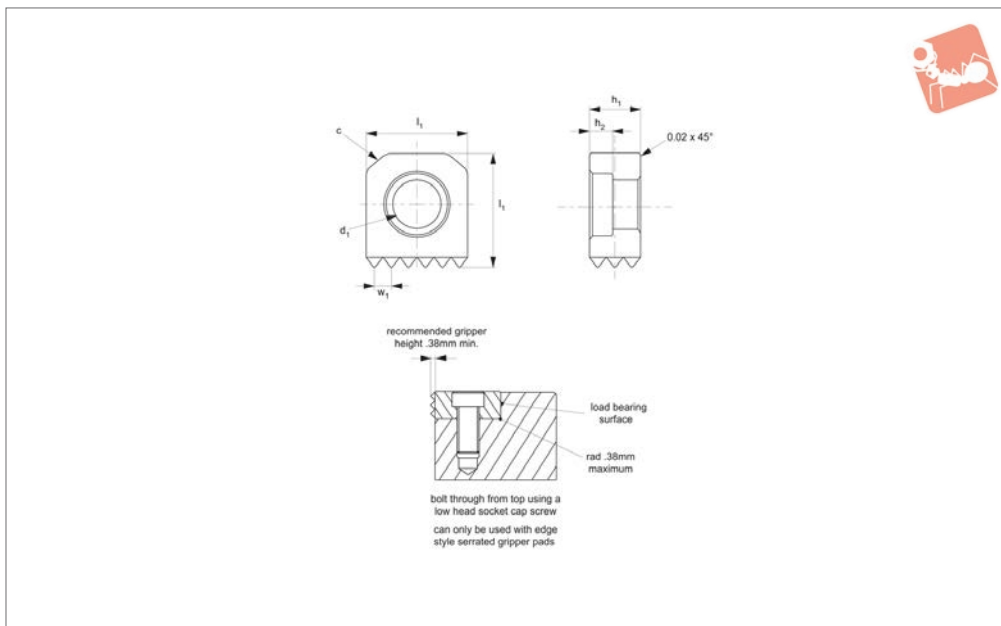

Material

Tool steel, hardened to HRC 60-62.

Technical Notes

Square edge grippers have serrations on

one side. Counterbored hole for front mounting with a socket head or low head cap screw (SHCS - socket head cap screw, LHCS- low head cap screw).

Order No.	Tooth pattern	Serration type	l_1 +0.00 -0.13	d_1	h_1 +0.00 -0.13	h_2	Chamfer c	w_1
35520.W0201	Extra Fine	Diamond	10	M 3 SHCS	6	3.8	1,6x45°	2,4x90°
35520.W0202	Extra Fine	Diamond	10	M 3 SHCS	10	3.8	1,6x45°	2,4x90°
35520.W0203	Fine	Diamond	12	M 4 SHCS	6	4.1	2,3x45°	3,2x90°
35520.W0204	Fine	Diamond	12	M 4 SHCS	10	4.1	2,3x45°	3,2x90°
35520.W0205	Fine	Diamond	12	M 4 SHCS	12	4.1	2,3x45°	3,2x90°
35520.W0206	Fine	Diamond	16	M 6 LHCS	6	4.2	3,2x45°	3,2x90°
35520.W0207	Fine	Diamond	16	M 6 LHCS	10	4.2	3,2x45°	3,2x90°
35520.W0208	Fine	Diamond	16	M 6 LHCS	12	5.1	3,2x45°	3,2x90°
35520.W0209	Fine	Diamond	20	M 8 LHCS	6	5.1	3,2x45°	3,2x90°
35520.W0210	Fine	Diamond	20	M 8 LHCS	10	5.1	3,2x45°	3,2x90°
35520.W0211	Fine	Diamond	20	M 8 LHCS	12	5.1	3,2x45°	3,2x90°
35520.W0212	Fine	Diamond	25	M10 LHCS	10	6.6	3,2x45°	3,2x90°
35520.W0213	Fine	Diamond	25	M10 LHCS	12	6.6	3,2x45°	3,2x90°
35520.W0301	Extra Fine	Straight	10	M 3 SHCS	6	3.8	1,6x45°	2,4x90°
35520.W0302	Extra Fine	Straight	10	M 3 SHCS	10	3.8	1,6x45°	2,4x90°
35520.W0303	Fine	Straight	12	M 4 SHCS	6	4.1	2,3x45°	3,2x90°
35520.W0304	Fine	Straight	12	M 4 SHCS	10	4.1	2,3x45°	3,2x90°
35520.W0305	Fine	Straight	12	M 4 SHCS	12	4.1	2,3x45°	3,2x90°
35520.W0306	Fine	Straight	16	M 6 LHCS	6	4.2	3,2x45°	3,2x90°
35520.W0307	Fine	Straight	16	M 6 LHCS	10	4.2	3,2x45°	3,2x90°
35520.W0308	Fine	Straight	16	M 6 LHCS	12	4.2	3,2x45°	3,2x90°
35520.W0309	Fine	Straight	20	M 8 LHCS	6	5.1	3,2x45°	3,2x90°
35520.W0310	Fine	Straight	20	M 8 LHCS	10	5.1	3,2x45°	3,2x90°
35520.W0311	Fine	Straight	20	M 8 LHCS	12	5.1	3,2x45°	3,2x90°
35520.W0312	Fine	Straight	25	M10 LHCS	10	6.6	3,2x45°	3,2x90°
35520.W0313	Fine	Straight	25	M10 LHCS	12	6.6	3,2x45°	3,2x90°



35530.1

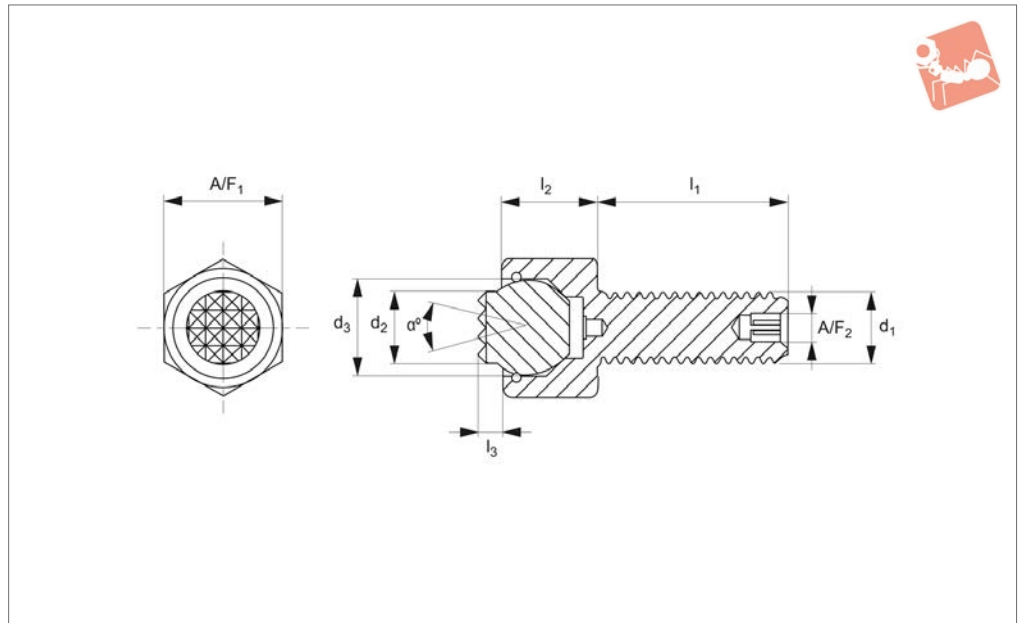

GRIPPERS & REST PADS

Material

Body: steel, hardened to HRc 43/46, black oxide finish.

Ball: M2 high speed steel, hardened to HRc 60/62.

Viton o-ring holds ball in place and prevents ingress of other material.

Technical Notes

These adjustable self-aligning pads serve

as stops, supports and thrust elements in jigs and fixtures. They can also be fitted to existing workholding elements.

Use low-profile hexagon nut (DIN 439B) for adjustment and securing if required.

Order No.	Tooth pattern	d ₁	d ₂	d ₃	l ₁	l ₂ ±0.05	l ₃	Swivel angle a	Load rating kg	A/F ₁	A/F ₂
35530.W0001	Super Fine	M6X1,0	6.0	7	12	8.0	1.5	28	935	10	-
35530.W0002	Super Fine	M6X1,0	6.0	7	12	8.0	3.0	28	935	10	-
35530.W0003	Super Fine	M6X1,0	6.0	7	25	8.0	1.5	28	935	10	-
35530.W0004	Super Fine	M6X1,0	6.0	7	25	8.0	3.0	28	935	10	-
35530.W0005	Super Fine	M6X1,0	6.0	7	40	8.0	1.5	28	935	10	-
35530.W0006	Super Fine	M6X1,0	6.0	7	40	8.0	3.0	28	935	10	-
35530.W0007	Extra Fine	M8X1,25	8.5	10	12	11.5	1.5	24	1565	13	-
35530.W0008	Extra Fine	M8X1,25	8.5	10	12	11.5	3.0	24	1565	13	-
35530.W0009	Extra Fine	M8X1,25	8.5	10	25	11.5	1.5	24	1565	13	-
35530.W0010	Extra Fine	M8X1,25	8.5	10	25	11.5	3.0	24	1565	13	-
35530.W0011	Extra Fine	M8X1,25	8.5	10	40	11.5	1.5	24	1565	13	-
35530.W0012	Extra Fine	M8X1,25	8.5	10	40	11.5	3.0	24	1565	13	-
35530.W0013	Extra Fine	M10X1,5	10.0	13	15	13.0	4.0	42	1902	17	3
35530.W0014	Extra Fine	M10X1,5	10.0	13	15	13.0	6.0	42	1902	17	3
35530.W0015	Extra Fine	M10X1,5	10.0	13	30	13.0	4.0	42	1902	17	3
35530.W0016	Extra Fine	M10X1,5	10.0	13	30	13.0	6.0	42	1902	17	3
35530.W0017	Extra Fine	M10X1,5	10.0	13	50	13.0	4.0	42	1902	17	3
35530.W0018	Extra Fine	M10X1,5	10.0	13	50	13.0	6.0	42	1902	17	3
35530.W0019	Fine	M12X1,75	12.0	15	20	15.0	4.0	45	3006	19	5
35530.W0020	Fine	M12X1,75	12.0	15	20	15.0	6.0	45	3006	19	5
35530.W0021	Fine	M12X1,75	12.0	15	40	15.0	4.0	45	3006	19	5
35530.W0022	Fine	M12X1,75	12.0	15	40	15.0	6.0	45	3006	19	5
35530.W0023	Fine	M12X1,75	12.0	15	60	15.0	4.0	45	3006	19	5
35530.W0024	Fine	M12X1,75	12.0	15	60	15.0	6.0	45	3006	19	5
35530.W0025	Fine	M16X2,0	16.0	20	25	19.0	4.0	40	5073	24	6
35530.W0027	Fine	M16X2,0	16.0	20	50	19.0	4.0	40	5073	24	6
35530.W0028	Fine	M16X2,0	16.0	20	50	19.0	6.0	40	5073	24	6
35530.W0029	Fine	M16X2,0	16.0	20	80	19.0	4.0	40	5073	24	6
35530.W0030	Fine	M16X2,0	16.0	20	80	19.0	6.0	40	5073	24	6



Grippers - Self Aligning - HTS

flat - threaded bolt

Grippers & Rest Pads

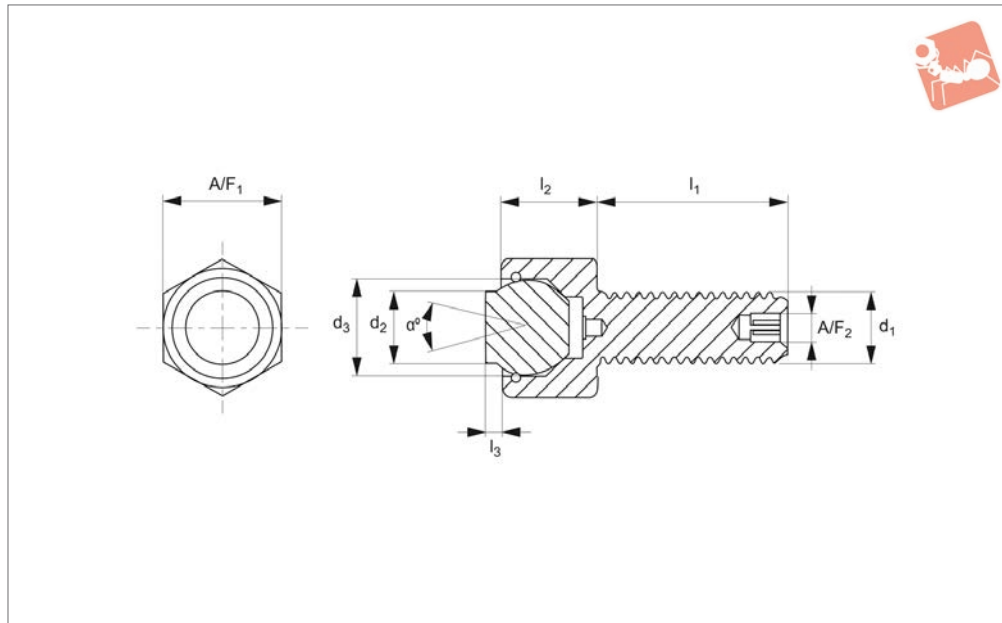

35530.2

GRIPPERS & REST PADS

Material

Body: steel, hardened to HRC 43/46, black oxide finish.

Ball: M2 high speed steel, hardened to HRC 60/62.

Viton o-ring holds ball in place and prevents ingress of other material.

Technical Notes

These adjustable self-aligning pads serve

as stops, supports and thrust elements in jigs and fixtures. They can also be fitted to existing workholding elements.

Use low-profile hexagon nut (DIN 439B) for adjustment and securing if required.

Order No.	d ₁	d ₂	d ₃	l ₁	l ₂ ±0.05	l ₃	Swivel angle °	Load rating kg	A/F ₁	A/F ₂
35530.W0101	M6X1,0	6.0	7	12	8.0	1.5	28	935	10	-
35530.W0102	M6X1,0	6.0	7	12	8.0	3.0	28	935	10	-
35530.W0103	M6X1,0	6.0	7	25	8.0	1.5	28	935	10	-
35530.W0104	M6X1,0	6.0	7	25	8.0	3.0	28	935	10	-
35530.W0105	M6X1,0	6.0	7	40	8.0	1.5	28	935	10	-
35530.W0106	M6X1,0	6.0	7	40	8.0	3.0	28	935	10	-
35530.W0107	M8X1,25	8.5	10	12	11.5	1.5	24	1565	13	-
35530.W0108	M8X1,25	8.5	10	12	11.5	3.0	24	1565	13	-
35530.W0109	M8X1,25	8.5	10	25	11.5	1.5	24	1565	13	-
35530.W0110	M8X1,25	8.5	10	25	11.5	3.0	24	1565	13	-
35530.W0111	M8X1,25	8.5	10	40	11.5	1.5	24	1565	13	-
35530.W0112	M8X1,25	8.5	10	40	11.5	3.0	24	1565	13	-
35530.W0113	M10X1,5	10.0	13	15	13.0	4.0	42	1902	17	3
35530.W0114	M10X1,5	10.0	13	15	13.0	6.0	42	1902	17	3
35530.W0115	M10X1,5	10.0	13	30	13.0	4.0	42	1902	17	3
35530.W0116	M10X1,5	10.0	13	30	13.0	6.0	42	1902	17	3
35530.W0117	M10X1,5	10.0	13	50	13.0	4.0	42	1902	17	3
35530.W0118	M10X1,5	10.0	13	50	13.0	6.0	42	1902	17	3
35530.W0119	M12X1,75	12.0	15	20	15.0	4.0	45	3006	19	5
35530.W0120	M12X1,75	12.0	15	20	15.0	6.0	45	3006	19	5
35530.W0121	M12X1,75	12.0	15	40	15.0	4.0	45	3006	19	5
35530.W0122	M12X1,75	12.0	15	40	15.0	6.0	45	3006	19	5
35530.W0123	M12X1,75	12.0	15	60	15.0	4.0	45	3006	19	5
35530.W0124	M12X1,75	12.0	15	60	15.0	6.0	45	3006	19	5
35530.W0125	M16X2,0	16.0	20	25	19.0	4.0	40	5073	24	6
35530.W0127	M16X2,0	16.0	20	50	19.0	4.0	40	5073	24	6
35530.W0129	M16X2,0	16.0	20	80	19.0	4.0	40	5073	24	6



35530.3

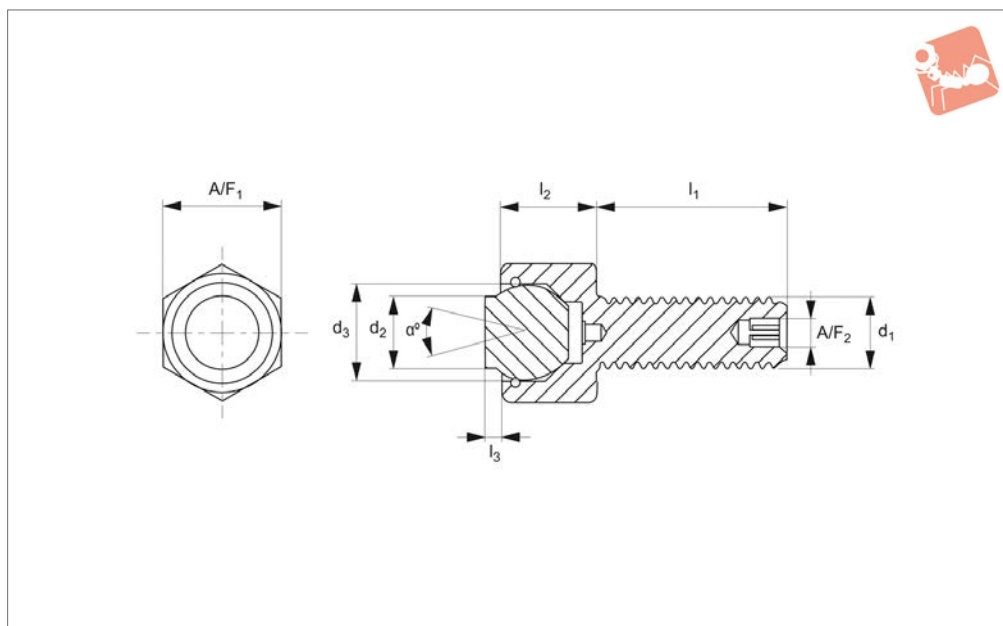

Material

Body: steel, hardened to HRc 43/46, black oxide finish.

Ball: thermoplastic, white.

Viton o-ring holds ball in place and

prevents ingress of other material.

Technical Notes

These adjustable self-aligning pads serve as stops, supports and thrust elements in

jigs and fixtures. They can also be fitted to existing workholding elements.

Use low-profile hexagon nut (DIN 439B) for adjustment and securing if required.

Order No.	d ₁	d ₂	d ₃	l ₁	l ₂ ±0.05	l ₃	Swivel angle α	A/F ₁	A/F ₂
35530.W0201	M 6X1,0	6.0	7	12	8.0	1.5	28	10	-
35530.W0202	M 6X1,0	6.0	7	12	8.0	3.0	28	10	-
35530.W0203	M 6X1,0	6.0	7	25	8.0	1.5	28	10	-
35530.W0204	M 6X1,0	6.0	7	25	8.0	3.0	28	10	-
35530.W0205	M 6X1,0	6.0	7	40	8.0	1.5	28	10	-
35530.W0206	M 6X1,0	6.0	7	40	8.0	3.0	28	10	-
35530.W0207	M 8X1,25	8.5	10	12	11.5	1.5	24	13	-
35530.W0208	M 8X1,25	8.5	10	12	11.5	3.0	24	13	-
35530.W0209	M 8X1,25	8.5	10	25	11.5	1.5	24	13	-
35530.W0210	M 8X1,25	8.5	10	25	11.5	3.0	24	13	-
35530.W0211	M 8X1,25	8.5	10	40	11.5	1.5	24	13	-
35530.W0212	M 8X1,25	8.5	10	40	11.5	3.0	24	13	-
35530.W0213	M10X1,5	10.0	13	15	13.0	4.0	42	17	3
35530.W0214	M10X1,5	10.0	13	15	13.0	6.0	42	17	3
35530.W0215	M10X1,5	10.0	13	30	13.0	4.0	42	17	3
35530.W0216	M10X1,5	10.0	13	30	13.0	6.0	42	17	3
35530.W0217	M10X1,5	10.0	13	50	13.0	4.0	42	17	3
35530.W0218	M10X1,5	10.0	13	50	13.0	6.0	42	17	3
35530.W0219	M12X1,75	12.0	15	20	15.0	4.0	45	19	5
35530.W0220	M12X1,75	12.0	15	20	15.0	6.0	45	19	5
35530.W0221	M12X1,75	12.0	15	40	15.0	4.0	45	19	5
35530.W0222	M12X1,75	12.0	15	40	15.0	6.0	45	19	5
35530.W0223	M12X1,75	12.0	15	60	15.0	4.0	45	19	5
35530.W0224	M12X1,75	12.0	15	60	15.0	6.0	45	19	5
35530.W0225	M16X2,0	16.0	20	25	19.0	4.0	40	24	6
35530.W0227	M16X2,0	16.0	20	50	19.0	4.0	40	24	6
35530.W0229	M16X2,0	16.0	20	80	19.0	4.0	40	24	6



Grippers - Self Aligning - HTS

serrated - female threaded housing

Grippers & Rest Pads

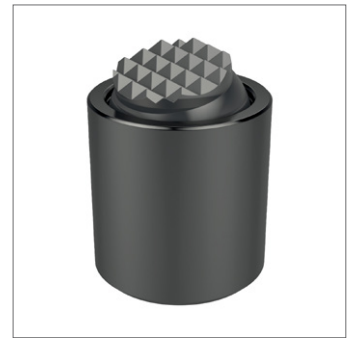
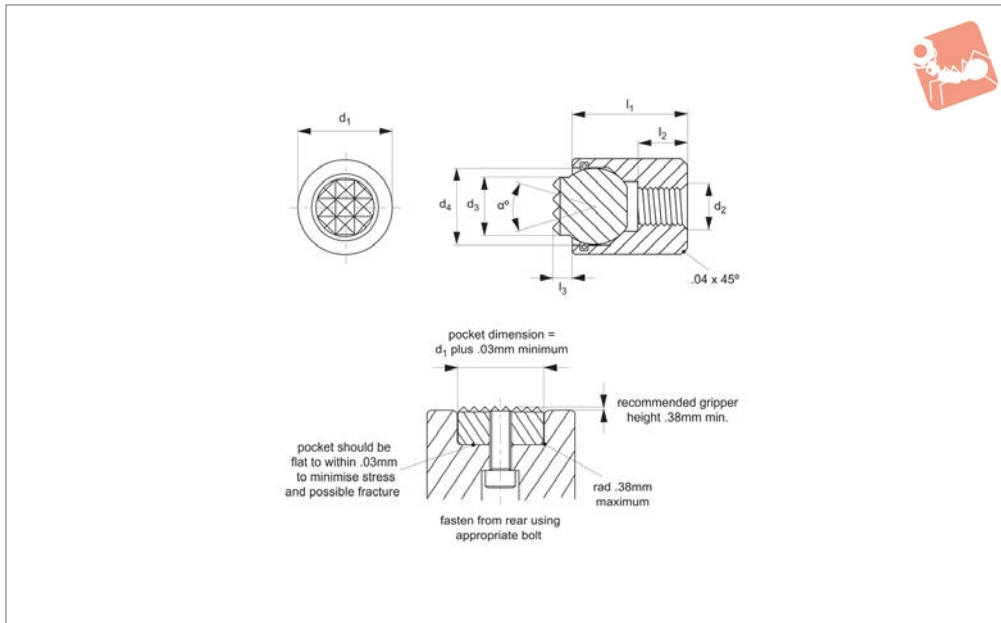

35540.1

GRIPPERS & REST PADS

Material

Body: steel, hardened to HRC 43/46, black oxide finish.

Ball: M2 high speed steel, hardened to HRC 60/62.

Viton o-ring holds ball in place and prevents ingress of other material.

Technical Notes

These adjustable self-aligning pads serve

as stops, supports and thrust elements in jigs and fixtures. They can also be fitted to existing workholding elements.

Use low-profile hexagon nut (DIN 439B) for adjustment and securing if required.

Order No.	Tooth pattern	Type	d_1 +0.00 -0.13	d_2	d_3	d_4	l_1 ±0.05	l_2 ±0.25	l_3	Swivel angle α	Load rating kg
35540.W0001	Super Fine	Serrated	10	M 4x0,7	6.0	7	10.5	3.5	1.5	28	1173
35540.W0002	Super Fine	Serrated	10	M 4x0,7	6.0	7	10.5	3.5	3.0	28	1173
35540.W0003	Super Fine	Serrated	10	M 4x0,7	6.0	7	23.5	9.0	1.5	28	1173
35540.W0004	Super Fine	Serrated	10	M 4x0,7	6.0	7	23.5	9.0	3.0	28	1173
35540.W0005	Extra Fine	Serrated	13	M 5x0,8	8.5	10	14.5	6.5	1.5	24	2019
35540.W0006	Extra Fine	Serrated	13	M 5x0,8	8.5	10	14.5	6.5	3.0	24	2019
35540.W0007	Extra Fine	Serrated	13	M 5x0,8	8.5	10	23.5	9.0	1.5	24	2019
35540.W0008	Extra Fine	Serrated	13	M 5x0,8	8.5	10	23.5	9.0	3.0	24	2019
35540.W0009	Extra Fine	Serrated	17	M 6x1,0	10.0	13	18.0	7.5	4.0	42	2799
35540.W0010	Extra Fine	Serrated	17	M 6x1,0	10.0	13	18.0	7.5	6.0	42	2799
35540.W0011	Fine	Serrated	19	M 8x1,25	12.0	15	20.0	8.5	4.0	45	3941
35540.W0012	Fine	Serrated	19	M 8x1,25	12.0	15	20.0	8.5	6.0	45	3941
35540.W0013	Fine	Serrated	24	M10x1,5	16.0	20	24.0	9.0	4.0	40	5950
35540.W0014	Fine	Serrated	24	M10x1,5	16.0	20	24.0	9.0	6.0	40	5950



35540.2

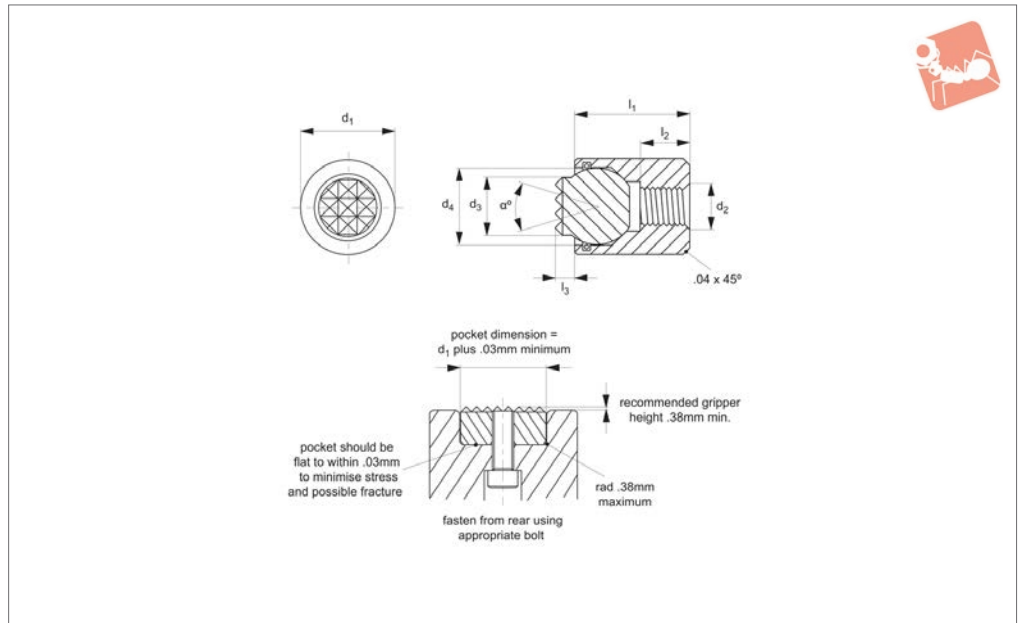

Material

Body: steel, hardened to HRc 43/46, black oxide finish.

Ball: M2 high speed steel, hardened to HRc 60/62.

Viton o-ring holds ball in place and prevents ingress of other material.

Technical Notes

These adjustable self-aligning pads serve

as stops, supports and thrust elements in jigs and fixtures. They can also be fitted to existing workholding elements.

Use low-profile hexagon nut (DIN 439B) for adjustment and securing if required.

Order No.	Type	d ₁	d ₂	d ₃	d ₄	l ₁ ±0.05	l ₂ ±0.25	l ₃	Swivel angle α	Load rating kg
35540.W0101	Flat, Steel	10	M 4 x 0,7	6.0	7	10.5	3.5	1.5	28	1173
35540.W0102	Flat, Steel	10	M 4 x 0,7	6.0	7	10.5	3.5	3.0	28	1173
35540.W0103	Flat, Steel	10	M 4 x 0,7	6.0	7	23.5	9.0	1.5	28	1173
35540.W0104	Flat, Steel	10	M 4 x 0,7	6.0	7	23.5	9.0	3.0	28	1173
35540.W0105	Flat, Steel	13	M 5 x 0,8	8.5	10	14.5	6.5	1.5	24	2019
35540.W0106	Flat, Steel	13	M 5 x 0,8	8.5	10	14.5	6.5	3.0	24	2019
35540.W0107	Flat, Steel	13	M 5 x 0,8	8.5	10	23.5	9.0	1.5	24	2019
35540.W0108	Flat, Steel	13	M 5 x 0,8	8.5	10	23.5	9.0	3.0	24	2019
35540.W0109	Flat, Steel	17	M 6 x 1,0	10.0	13	18.0	7.5	4.0	42	2799
35540.W0110	Flat, Steel	17	M 6 x 1,0	10.0	13	18.0	7.5	6.0	42	2799
35540.W0111	Flat, Steel	19	M 8 x 1,25	12.0	15	20.0	8.5	4.0	45	3941
35540.W0112	Flat, Steel	19	M 8 x 1,25	12.0	15	20.0	8.5	6.0	45	3941
35540.W0113	Flat, Steel	24	M10 x 1,5	16.0	20	24.0	9.0	4.0	40	5950
35540.W0114	Flat, Steel	24	M10 x 1,5	16.0	20	24.0	9.0	6.0	40	5950



Grippers - Self Aligning - Plastic flat - female threaded housing

Grippers & Rest Pads

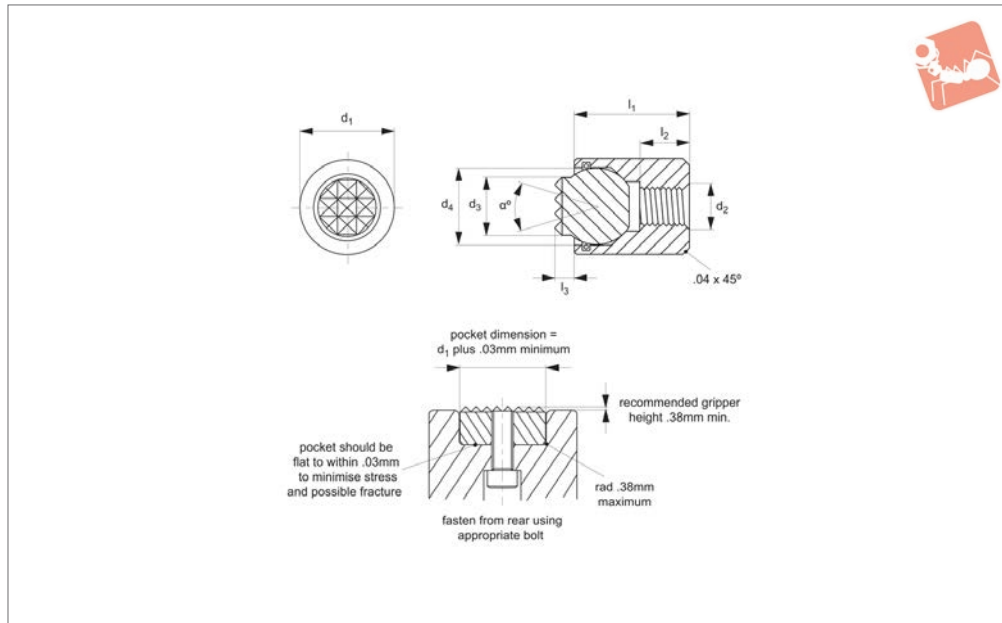

35540.3

GRIPPERS & REST PADS

Material

Body: steel, hardened to HRC 43/46, black oxide finish.

Ball: thermoplastic, white.

Viton o-ring holds ball in place and

prevents ingress of other material.

Technical Notes

These adjustable self-aligning pads serve as stops, supports and thrust elements in

jigs and fixtures. They can also be fitted to existing workholding elements.

Use low-profile hexagon nut (DIN 439B) for adjustment and securing if required.

Order No.	Type	d ₁	d ₂	d ₃	d ₄	l ₁ ±0.05	l ₂ ±0.25	l ₃	Swivel angle α
35540.W0201	Flat, Plastic	10	M 4 x 0,7	6.0	7.0	10.5	3.5	1.5	28
35540.W0202	Flat, Plastic	10	M 4 x 0,7	6.0	7.0	10.5	3.5	3.0	28
35540.W0203	Flat, Plastic	10	M 4 x 0,7	6.0	7.0	23.5	9.0	1.5	28
35540.W0204	Flat, Plastic	10	M 4 x 0,7	6.0	7.0	23.5	9.0	3.0	28
35540.W0205	Flat, Plastic	13	M 5 x 0,8	8.5	10.0	14.5	6.5	1.5	24
35540.W0206	Flat, Plastic	13	M 5 x 0,8	8.5	10.0	14.5	6.5	3.0	24
35540.W0207	Flat, Plastic	13	M 5 x 0,8	8.5	10.0	23.5	9.0	1.5	24
35540.W0208	Flat, Plastic	13	M 5 x 0,8	8.5	10.0	23.5	9.0	3.0	24
35540.W0209	Flat, Plastic	17	M 6 x 1,0	10.0	13.0	18.0	7.5	4.0	42
35540.W0210	Flat, Plastic	17	M 6 x 1,0	10.0	13.0	18.0	7.5	6.0	42
35540.W0211	Flat, Plastic	19	M 8 x 1,25	12.0	15.0	20.0	8.5	4.0	45
35540.W0212	Flat, Plastic	19	M 8 x 1,25	12.0	15.0	20.0	8.5	6.0	45
35540.W0213	Flat, Plastic	24	M10 x 1,5	16.0	20.0	24.0	9.0	4.0	40
35540.W0214	Flat, Plastic	24	M10 x 1,5	16.0	20.0	24.0	9.0	6.0	40



35550.1

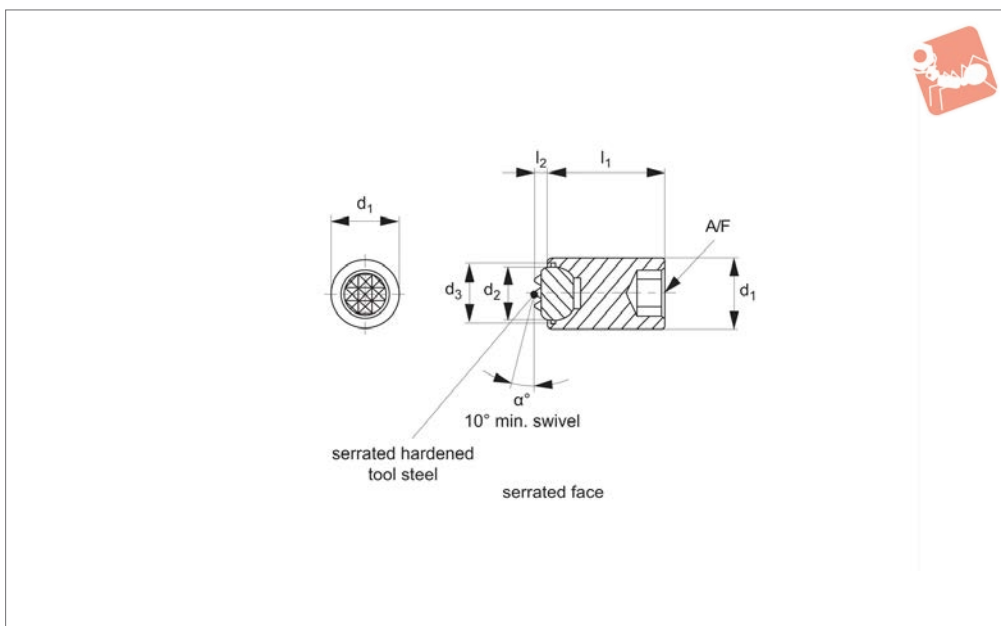

Material

Body: steel set screw with hardened tool steel or thermoplastic inserts.

Technical Notes

These adjustable ball end gripping screws also serve as stops, supports elements.

They can be inserted into jigs, fixtures and other workholding elements.

Order No.	Tooth pattern	d_1 +0.00 -0.13	d_2	d_3	l_1	l_2	Swivel angle α °	Load rating kg	A/F
35550.W0001	Super Fine	4	M10x1,5	5	25	1.5	30	-	5
35550.W0002	Super Fine	4	M10x1,5	5	35	1.5	30	-	5
35550.W0003	Super Fine	4	M10x1,5	5	50	1.5	30	-	5
35550.W0004	Super Fine	6	M12x1,75	7	25	1.5	28	1560	6
35550.W0005	Super Fine	6	M12x1,75	7	25	3.0	28	1560	6
35550.W0006	Super Fine	6	M12x1,75	7	35	1.5	28	1560	6
35550.W0007	Super Fine	6	M12x1,75	7	35	3.0	28	1560	6
35550.W0008	Super Fine	6	M12x1,75	7	50	1.5	28	1560	6
35550.W0009	Super Fine	6	M12x1,75	7	50	3.0	28	1560	6
35550.W0010	Extra Fine	8.5	M16x2,0	10	25	1.5	24	2354	8
35550.W0011	Extra Fine	8.5	M16x2,0	10	25	3.0	24	2354	8
35550.W0012	Extra Fine	8.5	M16x2,0	10	35	1.5	24	2354	8
35550.W0013	Extra Fine	8.5	M16x2,0	10	35	3.0	24	2354	8
35550.W0014	Extra Fine	8.5	M16x2,0	10	50	1.5	24	2354	8
35550.W0015	Extra Fine	8.5	M16x2,0	10	50	3.0	24	2354	8
35550.W0016	Extra Fine	10	M20x2,5	13	30	4.0	42	3800	10
35550.W0017	Extra Fine	10	M20x2,5	13	30	6.0	42	3800	10
35550.W0018	Extra Fine	10	M20x2,5	13	50	4.0	42	3800	10
35550.W0019	Extra Fine	10	M20x2,5	13	50	6.0	42	3800	10
35550.W0020	Extra Fine	10	M20x2,5	13	70	4.0	42	3800	10
35550.W0021	Extra Fine	10	M20x2,5	13	70	6.0	42	3800	10
35550.W0022	Fine	12	M24x3,0	15	40	4.0	45	5549	10
35550.W0023	Fine	12	M24x3,0	15	40	6.0	45	5549	10
35550.W0024	Fine	12	M24x3,0	15	80	4.0	45	5549	10
35550.W0025	Fine	12	M24x3,0	15	80	6.0	45	5549	10



Grippers - Self Aligning - HTS

flat - set screw

Grippers & Rest Pads

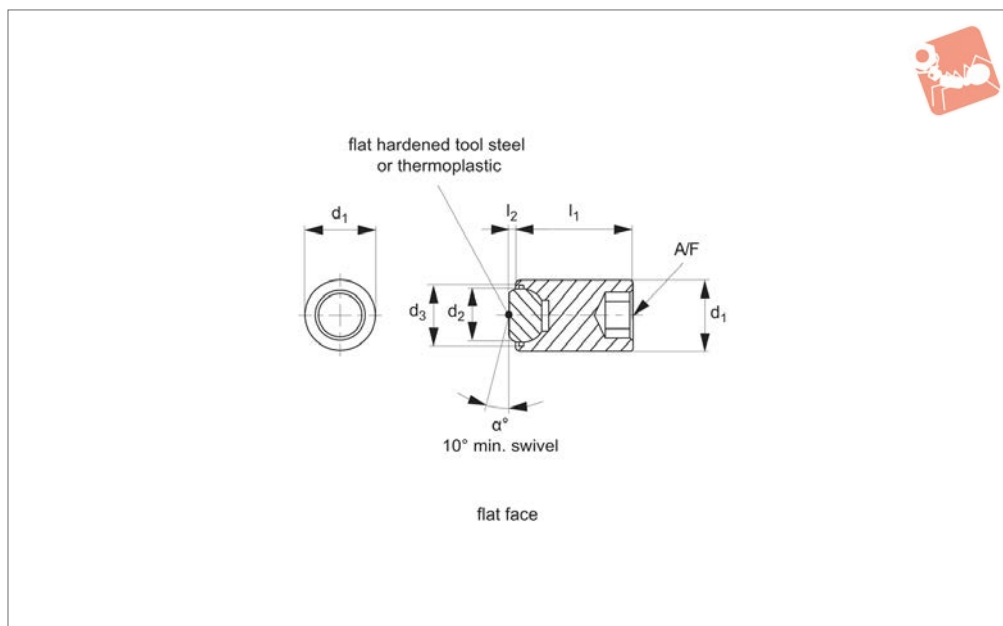

35550.2

GRIPPERS & REST PADS

Material

Body: steel set screw with hardened tool steel or thermoplastic inserts.

Technical Notes

These adjustable ball end gripping screws also serve as stops, supports elements.

They can be inserted into jigs, fixtures and other workholding elements.

Order No.	d_1 +0.00 -0.13	d_2	d_3	l_1	l_2	Swivel angle α	Load rating kg	A/F
35550.W0101	6.0	M12x1,75	7	25	1.5	28	1560	6
35550.W0102	6.0	M12x1,75	7	25	3.0	28	1560	6
35550.W0103	6.0	M12x1,75	7	35	1.5	28	1560	6
35550.W0104	6.0	M12x1,75	7	35	3.0	28	1560	6
35550.W0105	6.0	M12x1,75	7	50	1.5	28	1560	6
35550.W0106	6.0	M12x1,75	7	50	3.0	28	1560	6
35550.W0107	8.5	M16x2,0	10	25	1.5	24	2354	8
35550.W0108	8.5	M16x2,0	10	25	3.0	24	2354	8
35550.W0109	8.5	M16x2,0	10	35	1.5	24	2354	8
35550.W0110	8.5	M16x2,0	10	35	3.0	24	2354	8
35550.W0111	8.5	M16x2,0	10	50	1.5	24	2354	8
35550.W0112	8.5	M16x2,0	10	50	3.0	24	2354	8
35550.W0113	10.0	M20x2,5	13	30	4.0	42	3800	10
35550.W0114	10.0	M20x2,5	13	30	6.0	42	3800	10
35550.W0115	10.0	M20x2,5	13	50	4.0	42	3800	10
35550.W0116	10.0	M20x2,5	13	50	6.0	42	3800	10
35550.W0117	10.0	M20x2,5	13	70	4.0	42	3800	10
35550.W0118	10.0	M20x2,5	13	70	6.0	42	3800	10
35550.W0119	12.0	M24x3,0	15	40	4.0	45	5549	10
35550.W0120	12.0	M24x3,0	15	40	6.0	45	5549	10
35550.W0121	12.0	M24x3,0	15	80	4.0	45	5549	10
35550.W0122	12.0	M24x3,0	15	80	6.0	45	5549	10



35550.3

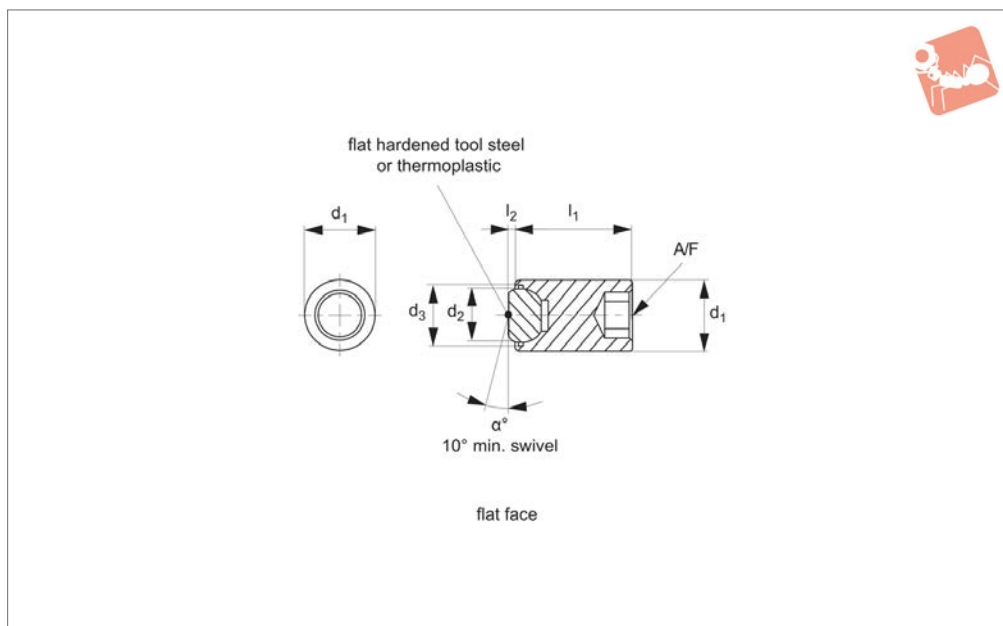

Material

Body: steel set screw with hardened tool steel or thermoplastic inserts.

Technical Notes

These adjustable ball end gripping screws also serve as stops, supports elements.

They can be inserted into jigs, fixtures and other workholding elements.

Order No.	d_1 +0.00 -0.13	d_2	d_3	l_1	l_2	Swivel angle α	Load rating kg	A/F
35550.W0201	6.0	M12x1,75	7	25	1.5	28	1560	6
35550.W0202	6.0	M12x1,75	7	25	3.0	28	1560	6
35550.W0203	6.0	M12x1,75	7	35	1.5	28	1560	6
35550.W0204	6.0	M12x1,75	7	35	3.0	28	1560	6
35550.W0205	6.0	M12x1,75	7	50	1.5	28	1560	6
35550.W0206	6.0	M12x1,75	7	50	3.0	28	1560	6
35550.W0207	8.5	M16x2,0	10	25	1.5	24	2354	8
35550.W0208	8.5	M16x2,0	10	25	3.0	24	2354	8
35550.W0209	8.5	M16x2,0	10	35	1.5	24	2354	8
35550.W0210	8.5	M16x2,0	10	35	3.0	24	2354	8
35550.W0211	8.5	M16x2,0	10	50	1.5	24	2354	8
35550.W0212	8.5	M16x2,0	10	50	3.0	24	2354	8
35550.W0213	10.0	M20x2,5	13	30	4.0	42	3800	10
35550.W0214	10.0	M20x2,5	13	30	6.0	42	3800	10
35550.W0215	10.0	M20x2,5	13	50	4.0	42	3800	10
35550.W0216	10.0	M20x2,5	13	50	6.0	42	3800	10
35550.W0217	10.0	M20x2,5	13	70	4.0	42	3800	10
35550.W0218	10.0	M20x2,5	13	70	6.0	42	3800	10
35550.W0219	12.0	M24x3,0	15	40	4.0	45	5549	10
35550.W0220	12.0	M24x3,0	15	40	6.0	45	5549	10
35550.W0221	12.0	M24x3,0	15	80	4.0	45	5549	10
35550.W0222	12.0	M24x3,0	15	80	6.0	45	5549	10



Grippers - Self Aligning - Housing

female threaded housing only

Grippers & Rest Pads

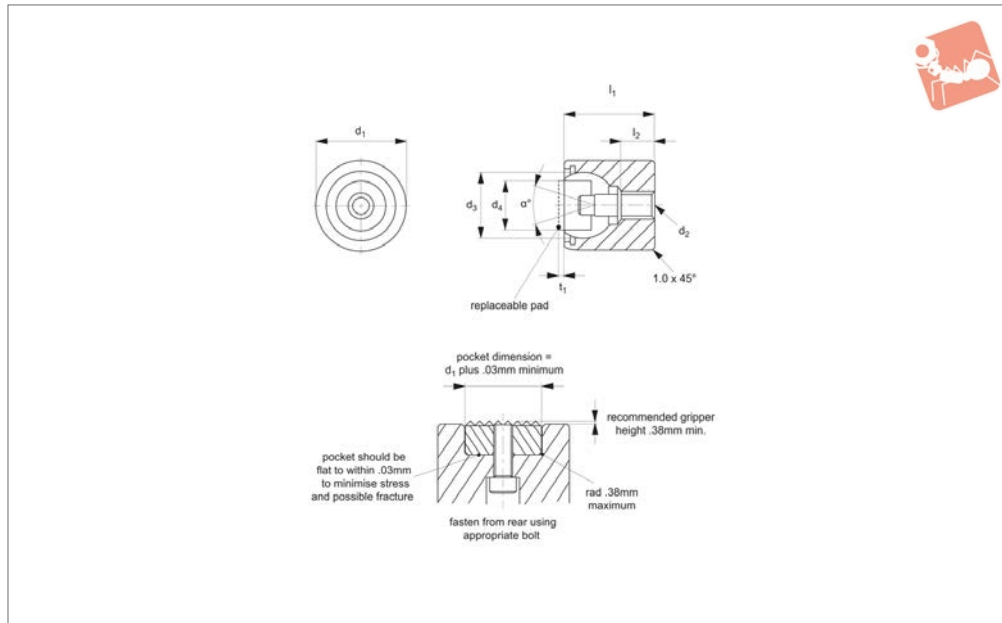

35580

GRIPPERS & REST PADS

Material

Body: steel, heat treated to HRC 43/46, back oxide finish.

Ball: stainless steel (440C), hardened to HRC58/60.

Technical Notes

These adjustable self-aligning ball units

accept inserts:

- no. 35330 carbide tipped grippers.
- no. 35450 hardened tool steel grippers.
- no. 35980 steel/thermoplastic rest pads.

These must be ordered separately.

These parts can serve as stops, supports and thrust elements in jigs and fixtures.

They can also be fitted to existing workholding elements.

Order No.	Ball dia. d_3	d_1 +0.00 -0.13	d_2	Replaceable pad dia. d_4	l_1 ± 0.05	l_2 ± 0.25	t_1	α °	Load kg max.
35580.W0001	13	17	M 6x1,0	10	18	7.5	4	20	2799
35580.W0004	15	19	M 8x1,25	12	20	8.5	4	20	3941
35580.W0007	20	24	M10x1,5	16	24	9.0	4	20	5952
35580.W0010	23	30	M12x1,75	20	26	8.5	4	20	9683
35580.W0013	28	36	M12x1,75	25	32	12.0	4	20	13861



35590

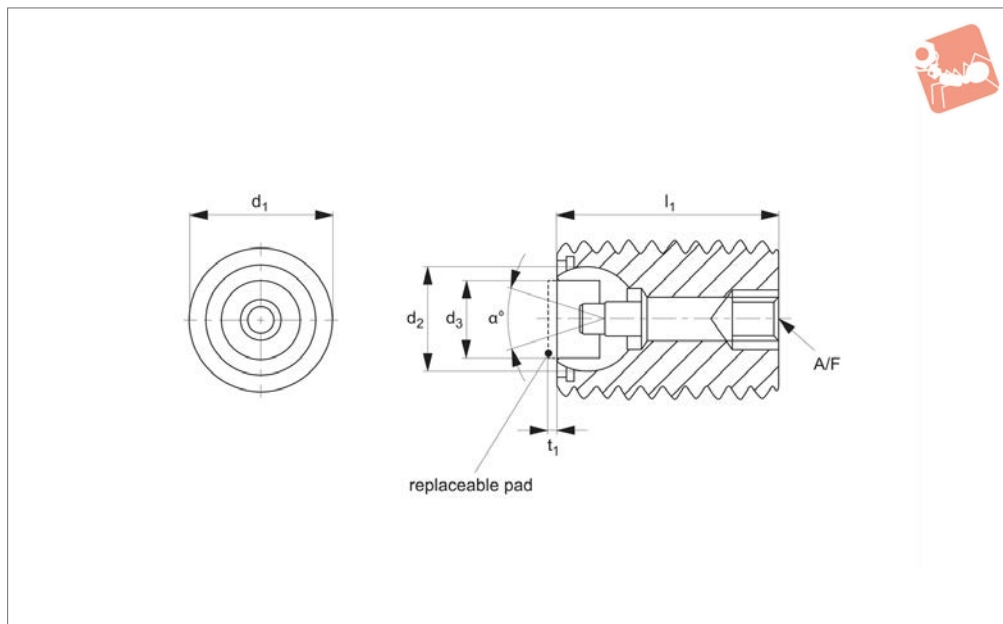

Material

Body: steel, heat treated to HRC 43/46, back oxide finish.
Ball: stainless steel (440C), hardened to HRC 58/60.

Technical Notes

These adjustable self-aligning ball units

accept inserts:

- no. 35330 carbide tipped grippers.
- no. 35450 hardened tool steel grippers.
- no. 35980 steel/thermoplastic rest pads.

These must be ordered separately.

These parts can serve as stops, supports and thrust elements in jigs and fixtures.

They can also be fitted to existing workholding elements.

Order No.	Ball dia. d_2	d_1	Replaceable pad dia. d_3	l_1	t_1	Swivel angle a	Load kg max.	A/F
35590.W0001	13	M20x2,5	10	30	6	20	3801	10
35590.W0004	13	M20x2,5	10	50	6	20	3801	10
35590.W0007	13	M20x2,5	10	70	6	20	3801	10
35590.W0010	15	M24x3,0	12	40	6	20	5549	10
35590.W0013	15	M24x3,0	12	80	6	20	5549	10



Rest Pads - Steel and Thermoplastic

round - rear fixing

Grippers & Rest Pads

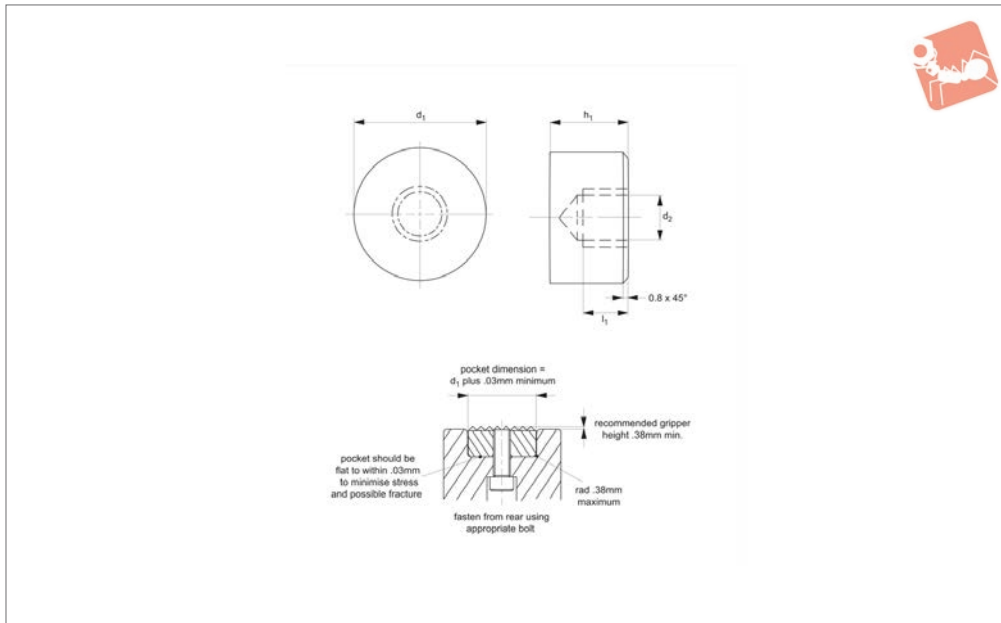

35980

GRIPPERS & REST PADS

Material

Steel (AISI 8620), hardened to HRc 58-60, black oxide finish.
Thermoplastic, white.

etc in jigs and fixtures.

$h_1 = \text{tol. of steel } \pm 0,03, \text{ tol. for thermo-plastic } +0,00 -0,13.$

differential screw. Note installation recommendations in technical diagram.

Technical Notes

Can be used as rest pads, stops, supports

Tips

Can be fastened from rear using appropriate bolt or alternatively via use of a

Order No.	Material	d_1 +0.00 -0.13	d_2	h_1	l_1
35980.W0011	Steel	8	M 4x0,7	10	5.0
35980.W0012	Steel	8	M 4x0,7	12	6.4
35980.W0001	Steel	10	M 5x0,8	10	5.0
35980.W0002	Steel	10	M 5x0,8	12	6.4
35980.W0003	Steel	12	M 5x0,8	10	5.0
35980.W0004	Steel	12	M 5x0,8	12	6.4
35980.W0005	Steel	16	M 6x1,0	10	5.0
35980.W0006	Steel	16	M 6x1,0	12	6.4
35980.W0007	Steel	20	M 6x1,0	10	5.0
35980.W0008	Steel	20	M 6x1,0	12	6.4
35980.W0009	Steel	25	M 6x1,0	10	5.0
35980.W0010	Steel	25	M 6x1,0	12	6.4
35980.W0211	Plastic	8	M 4x0,7	10	5.0
35980.W0212	Plastic	8	M 4x0,7	12	6.4
35980.W0201	Plastic	10	M 5x0,8	10	5.0
35980.W0202	Plastic	10	M 5x0,8	12	6.4
35980.W0203	Plastic	12	M 5x0,8	10	5.0
35980.W0204	Plastic	12	M 5x0,8	12	6.4
35980.W0205	Plastic	16	M 6x1,0	10	5.0
35980.W0206	Plastic	16	M 6x1,0	12	6.4
35980.W0207	Plastic	20	M 6x1,0	10	5.0
35980.W0208	Plastic	20	M 6x1,0	12	6.4
35980.W0209	Plastic	25	M 6x1,0	10	5.0
35980.W0210	Plastic	25	M 6x1,0	12	6.4

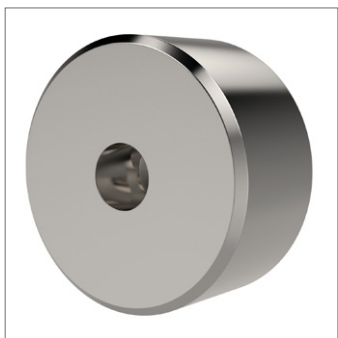

35982

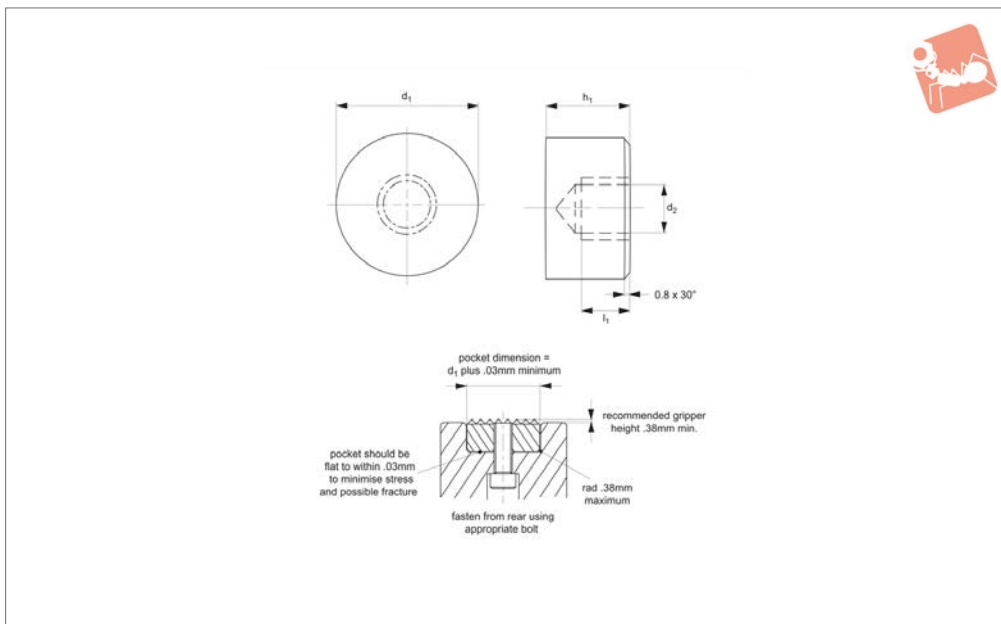

Material

Stainless steel (AISI 630), hardened to HRC 43-46.

Technical Notes

Can be used as rest pads, stops, supports

etc in jigs and fixtures.

Tips

Can be fastened from rear using appropriate bolt, or alternatively via use of a differential screw. Note installation recom-

mendations in technical diagram.

Order No.	d_1 +0.00 -0.13	d_2	h_1 ±0.03	l_1
35982.W0080	8	M 4x0,7	10	5.0
35982.W0082	8	M 4x0,7	12	6.4
35982.W0100	10	M 5x0,8	10	5.0
35982.W0102	10	M 5x0,8	12	6.4
35982.W0120	12	M 5x0,8	10	5.0
35982.W0122	12	M 5x0,8	12	6.4
35982.W0160	16	M 6x1,0	10	5.0
35982.W0162	16	M 6x1,0	12	6.4
35982.W0200	20	M 6x1,0	10	5.0
35982.W0202	20	M 6x1,0	12	6.4
35982.W0250	25	M 6x1,0	10	5.0
35982.W0252	25	M 6x1,0	12	6.4



Rest Pads - Steel and Thermoplastic

round - front fixing

Grippers & Rest Pads

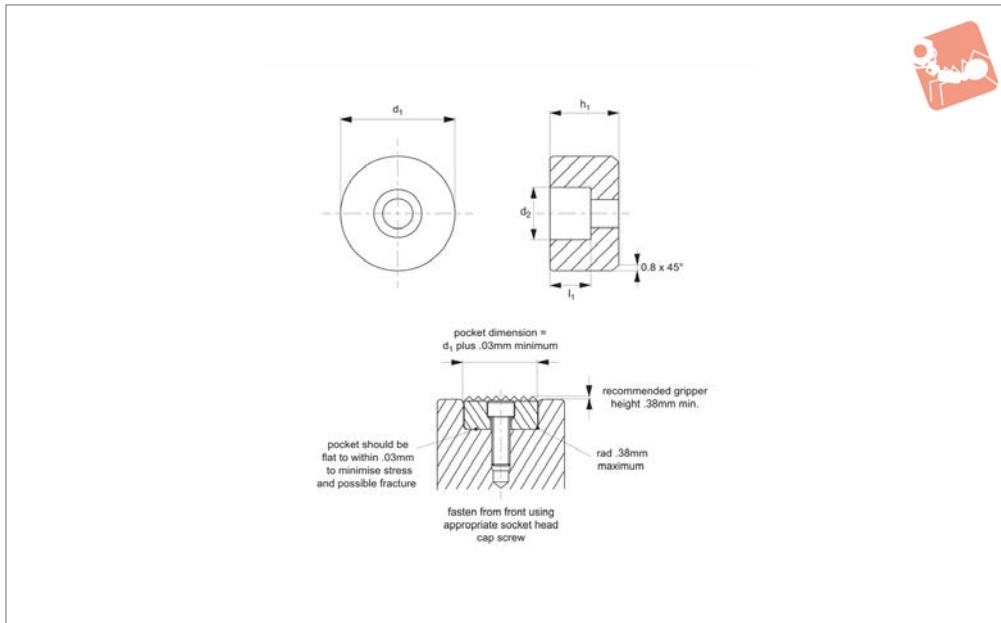

35984

GRIPPERS & REST PADS

Material

Steel (AISI 8620), hardened to HRC 58-60.
Black oxide finish.
Thermoplastic, white.

etc in jigs and fixtures.

$h_1 = \text{tol. of steel } \pm 0,03, \text{ tol. of thermoplastic } +0,00 -0,13.$

recommendations in technical diagram.

Technical Notes

Can be used as rest pads, stops, supports

Tips

Fasten from front using appropriate socket head cap screw. Note installation recom-

Order No.	Material	d_1 +0.00 -0.13	d_2 to fit DIN 912	h_1	l_1
35984.W0100	Steel	10	M 3	10	5.0
35984.W0102	Steel	10	M 3	12	5.0
35984.W0120	Steel	12	M 4	10	5.6
35984.W0122	Steel	12	M 4	12	5.6
35984.W0160	Steel	16	M 5	10	6.6
35984.W0162	Steel	16	M 5	12	6.6
35984.W0200	Steel	20	M 6	10	7.6
35984.W0202	Steel	20	M 6	12	7.6
35984.W0250	Steel	25	M 6	10	7.6
35984.W0252	Steel	25	M 6	12	7.6
35984.W1100	Plastic	10	M 3	10	5.0
35984.W1102	Plastic	10	M 3	12	5.0
35984.W1120	Plastic	12	M 4	10	5.6
35984.W1122	Plastic	12	M 4	12	5.6
35984.W1160	Plastic	16	M 5	10	6.6
35984.W1162	Plastic	16	M 5	12	6.6
35984.W1200	Plastic	20	M 6	10	7.6
35984.W1202	Plastic	20	M 6	12	7.6
35984.W1250	Plastic	25	M 6	10	7.6
35984.W1252	Plastic	25	M 6	12	7.6

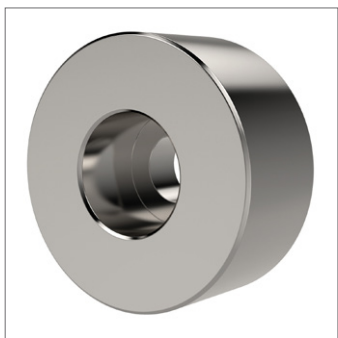

35986

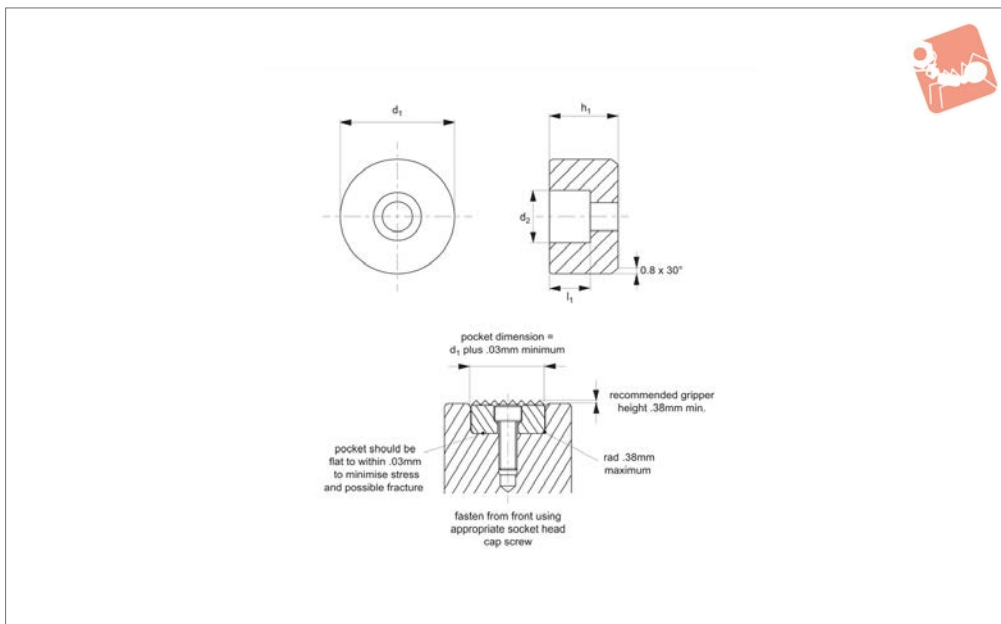

Material

Stainless steel (AISI 630), hardened to RHC 43-46.

well as protection against chemical and environmental corrosion.

recommendations in technical diagram.

Technical Notes

Stainless steel provides high strength as

Tips

Counterbored hole for front mounting with a socket head cap screw. Note installation

Order No.	d_1 +0.00 -0.13	d_2 to fit DIN 912	h_1 ±0.03	l_1
35986.W0100	10	M 3	10	5.0
35986.W0102	10	M 3	12	5.0
35986.W0120	12	M 4	10	5.6
35986.W0122	12	M 4	12	5.6
35986.W0160	16	M 5	10	6.6
35986.W0162	16	M 5	12	6.6
35986.W0200	20	M 6	10	7.6
35986.W0202	20	M 6	12	7.6
35986.W0250	25	M 6	10	7.6
35986.W0252	25	M 6	12	7.6



Gripping Pads - Diamond Coated

stainless - round - rear fixing

Grippers & Rest Pads

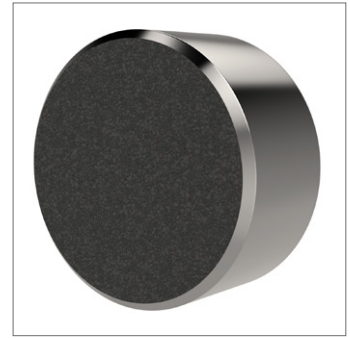
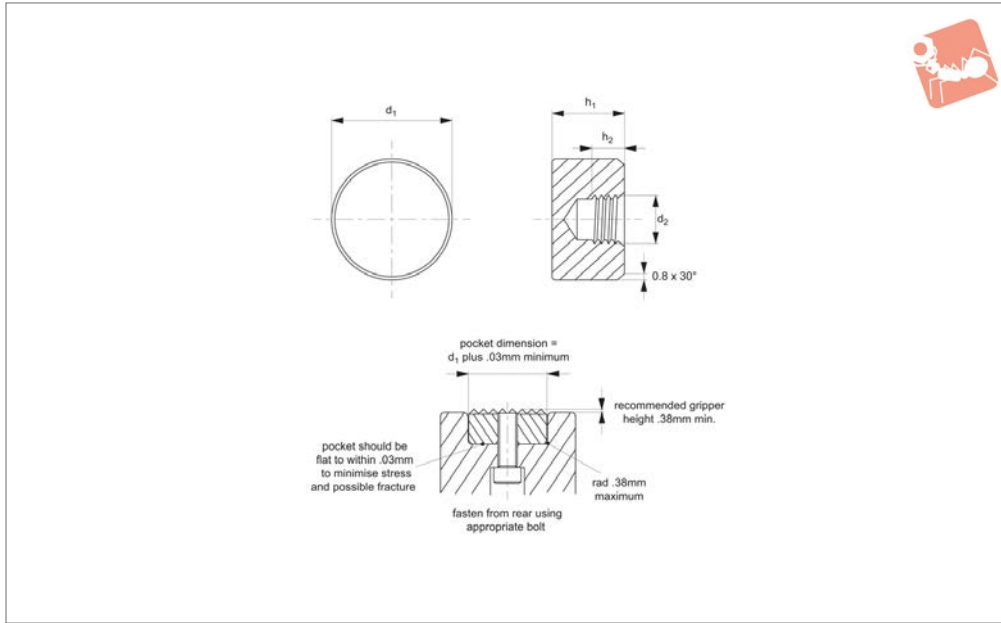

35630

GRIPPERS & REST PADS

Material

Stainless steel (AISI 630, precipitation-hardened), heat treated to HRC 43-46.

Technical Notes

Permanently fused diamond powder

creates an abrasive surface comparable to 100 grit abrasive value. Ideal for holding smooth or slippery components with a minimum of clamping pressure, and minimal surface marking. Excellent wear resistance.

Order No.	d_1 +0.00 -0.13	d_2	h_1 +0.00 -0.13	h_2
35630.W0841	8	M 4x0,7	10	5.0
35630.W0842	8	M 4x0,7	12	6.4
35630.W1051	10	M 5x0,8	10	5.0
35630.W1052	10	M 5x0,8	12	6.4
35630.W1251	12	M 5x0,8	10	5.0
35630.W1252	12	M 5x0,8	12	6.4
35630.W1661	16	M 6x1,0	10	5.0
35630.W1662	16	M 6x1,0	12	6.4
35630.W2061	20	M 6x1,0	10	5.0
35630.W2062	20	M 6x1,0	12	6.4
35630.W2561	25	M 6x1,0	10	5.0
35630.W2562	25	M 6x1,0	12	6.4

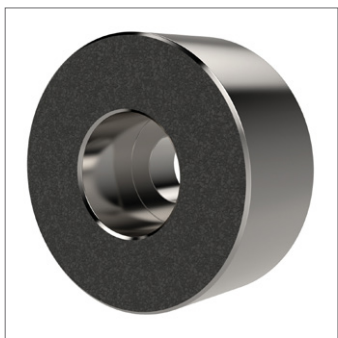

35632

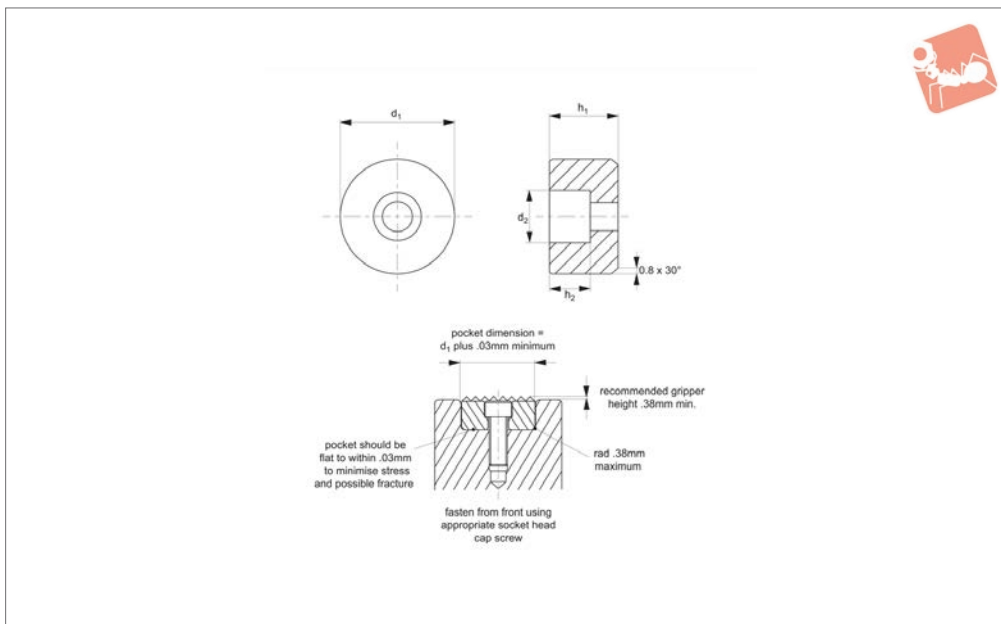

Material

Stainless steel (AISI 630, precipitation-hardened), heat treated to HRc 43-46.

Technical Notes

Permanently fused diamond powder

creates an abrasive surface comparable to 100 grit abrasive value. Ideal for holding smooth or slippery components with a minimum of clamping pressure, and minimal surface marking. Excellent wear resistance.

Order No.	d_1 +0.00 -0.13	d_2 to fit DIN 912	h_1 +0.00 -0.13	h_2
35632.W1051	10	M 3	10	5.0
35632.W1052	10	M 3	12	5.0
35632.W1251	12	M 4	10	5.6
35632.W1252	12	M 4	12	5.6
35632.W1661	16	M 5	10	6.6
35632.W1662	16	M 5	12	6.6
35632.W2061	20	M 6	10	7.6
35632.W2062	20	M 6	12	7.6
35632.W2561	25	M 6	10	7.6
35632.W2562	25	M 6	12	7.6



Grippers - Self Aligning diamond coated - threaded bolt

Grippers & Rest Pads

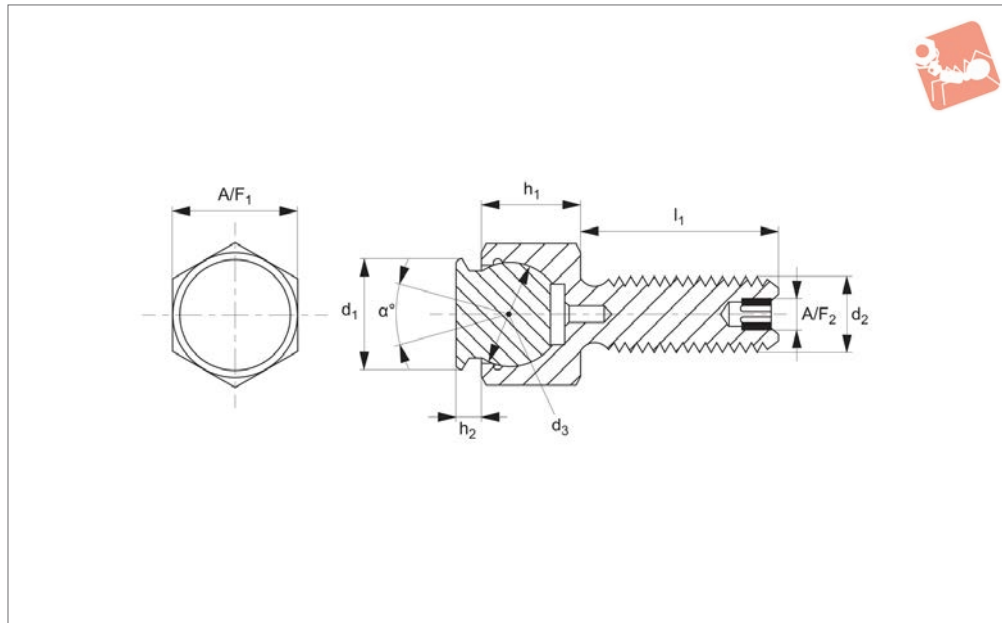

35640

GRIPPERS & REST PADS

Material

Housing body: alloy steel, heat treated to HRC 43-46, black oxide finish.

Pad: diamond powder bonded to AISI 300 series stainless steel ball.

creates an abrasive surface comparable to 100 grit abrasive value. Ideal for holding smooth or slippery components with a minimum of clamping pressure, and minimal surface marking. Excellent wear resistance.

Tips

Re-seating: expel air by using 0.3 monofilament line between ball and housing, remove line when seated correctly.

Technical Notes

Permanently fused diamond powder

Order No.	d ₁	d ₂	d ₃	h ₁ ±0.05	h ₂	l ₁	A/F ₁	A/F ₂	Swivel angle a	Load kg max.
35640.W0861	8	M 6x1,0	7	8.0	2	12	10	-	28	935
35640.W0862	8	M 6x1,0	7	8.0	2	25	10	-	28	935
35640.W0863	8	M 6x1,0	7	8.0	2	40	10	-	28	935
35640.W1181	11	M 8x1,25	10	11.5	3	12	13	-	28	1565
35640.W1182	11	M 8x1,25	10	11.5	3	25	13	-	28	1565
35640.W1183	11	M 8x1,25	10	11.5	3	40	13	-	28	1565
35640.W1410	14	M10x1,5	13	13.0	3	15	17	3	28	1902
35640.W1412	14	M10x1,5	13	13.0	3	30	17	3	28	1902
35640.W1413	14	M10x1,5	13	13.0	3	50	17	3	28	1902
35640.W1912	19	M12x1,75	15	15.0	4	20	19	5	24	3006
35640.W1913	19	M12x1,75	15	15.0	4	40	19	5	24	3006
35640.W1914	19	M12x1,75	15	15.0	4	60	19	5	24	3006
35640.W2116	21	M16x2,0	20	19.0	4	25	24	6	24	5073
35640.W2117	21	M16x2,0	20	19.0	4	50	24	6	24	5073
35640.W2118	21	M16x2,0	20	19.0	4	80	24	6	24	5073



35642

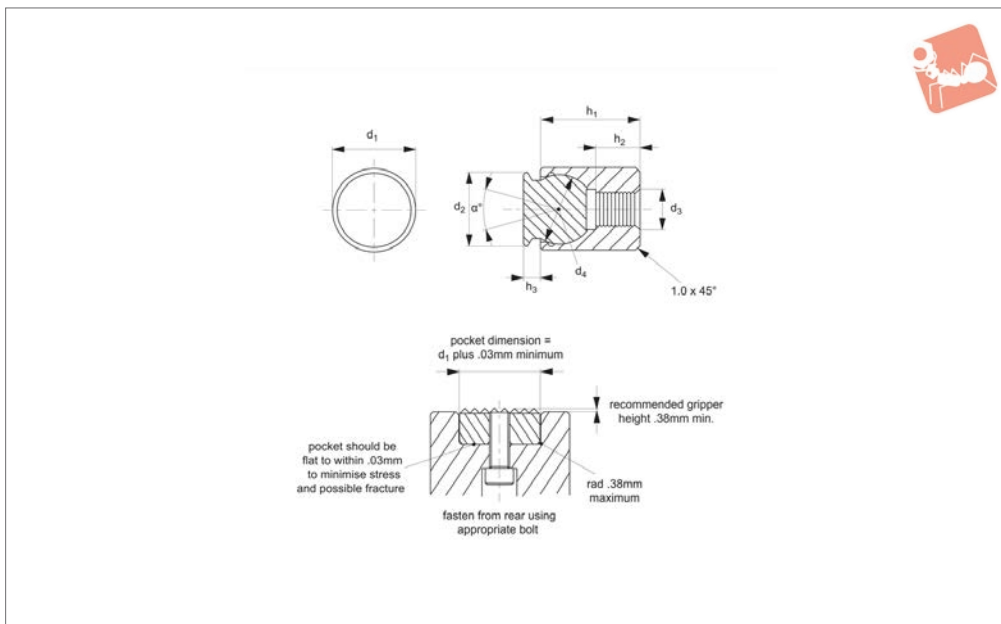

Material

Housing: alloy steel, heat treated to HRC 43-46 with black oxide finish.

Pad: diamond powder bonded to AISI 300 series stainless steel ball.

Technical Notes

Permanently fused diamond powder

creates an abrasive surface comparable to 100 grit abrasive value. Ideal for holding smooth or slippery components with a minimum of clamping pressure, and minimal surface marking. Excellent wear resistance.

Tips

Re-seating: expel air by using 0,3 monofilament line between ball and housing, remove line when seated correctly.

Order No.	d_1 +0.00 -0.13	d_2 +0.00 -0.13	d_3	d_4	h_1 ±0.05	h_2 ±0.25	h_3	Swivel angle α	Load kg max.
35642.W0841	10	8	M 4x0,7	7	10.5	3.5	2	28	1.2
35642.W0842	10	8	M 4x0,7	7	23.5	9.0	2	28	1.2
35642.W1151	13	11	M 5x0,8	10	14.5	6.5	3	28	2.0
35642.W1152	13	11	M 5x0,8	10	23.5	9.0	3	28	2.0
35642.W1461	17	14	M 6x1,0	13	18.0	7.5	3	28	2.8
35642.W1981	19	19	M 8x1,25	15	20.0	8.5	4	24	3.9
35642.W2110	24	21	M10x1,5	20	24.0	9.0	4	24	6.0

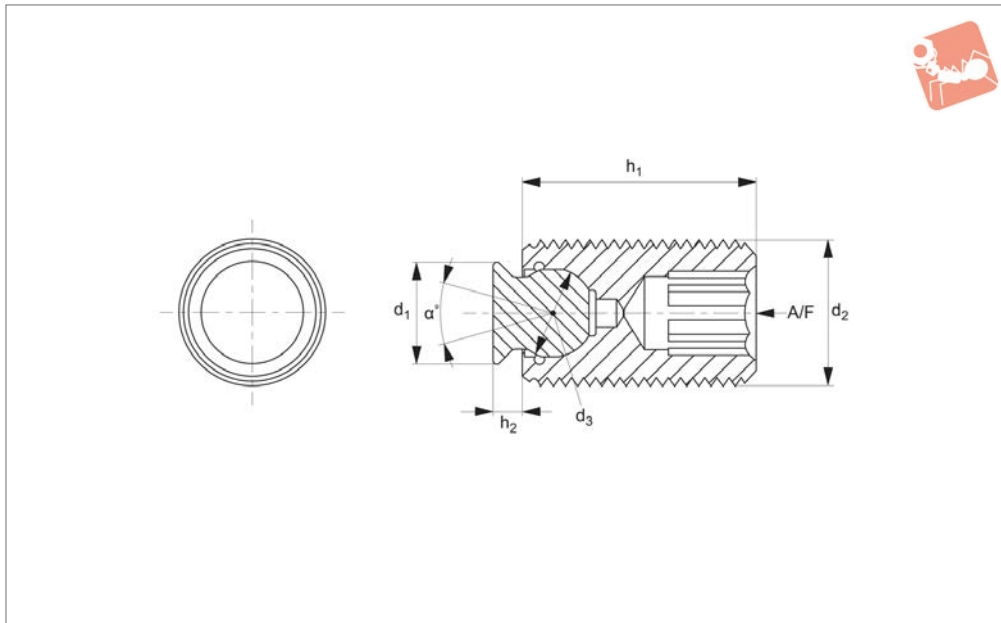

35644

GRIPPERS & REST PADS

Material

Housing: alloy steel, heat treated to HRC 43-46 with black oxide finish.
Pad: diamond powder bonded to AISI 300 series stainless steel ball.

creates an abrasive surface comparable to 100 grit abrasive value. Ideal for holding smooth or slippery components with a minimum of clamping pressure, and minimal surface marking. Excellent wear resistance.

Tips

Re-seating: expel air by using 0,3 monofilament line between ball and housing, remove line when seated correctly.

Technical Notes

Permanently fused diamond powder

Order No.	d ₁	d ₂	d ₃	h ₁	h ₂	A/F	Swivel angle a	Load kg max.
35644.W0610	6	M10x1,5	5	25	1.5	5	28	-
35644.W0611	6	M10x1,5	5	35	1.5	5	28	-
35644.W0612	6	M10x1,5	5	50	1.5	5	28	-
35644.W0812	8	M12x1,75	7	25	2.0	6	28	1.6
35644.W0813	8	M12x1,75	7	35	2.0	6	28	1.6
35644.W0814	8	M12x1,75	7	50	2.0	6	28	1.6
35644.W1116	11	M16x2,0	10	25	3.0	8	28	2.4
35644.W1117	11	M16x2,0	10	35	3.0	8	28	2.4
35644.W1118	11	M16x2,0	10	50	3.0	8	28	2.4
35644.W1420	14	M20x2,5	13	30	3.0	10	28	3.8
35644.W1421	14	M20x2,5	13	50	3.0	10	28	3.8
35644.W1422	14	M20x2,5	13	70	3.0	10	28	3.8
35644.W1924	19	M24x3,0	15	40	4.0	10	24	5.6
35644.W1925	19	M24x3,0	15	80	4.0	10	24	5.6



35610

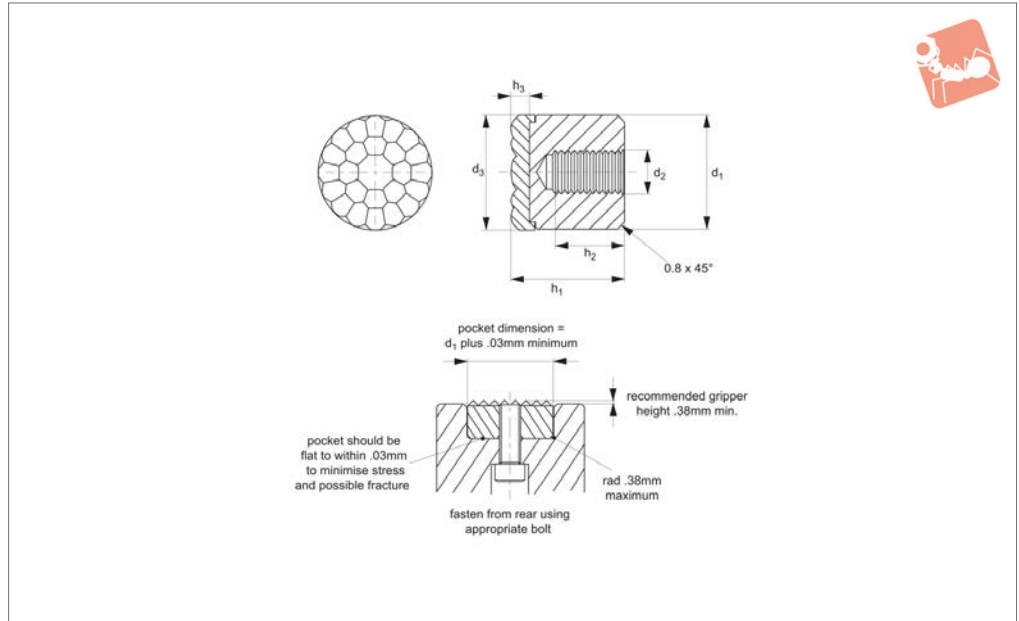

Material

Body: AISI 300 series stainless steel.

Pad: urethane; non-marking, non-staining

Technical Notes

Non-marking, non-staining urethane pad is permanently bonded to the stainless

steel body. Available in three different durometers: 35, 60 &80 (see table).

Bubbled texture of urethane pad allows air to escape so avoiding any suction action.

Important Notes

Load compression ratings based on load

required to compress urethane surface 0,812mm for 2mm thick pad. Compression ratings vary greatly depending upon temperature and other application-specific factors.

Order No.	d_1 +0.00 -0.13	d_2	d_3	h_1	h_2	Urethane thickness h_3	Durometer	Load compression kg
35610.W0083	8	M 4x0,7	8	12	6	2	35	4
35610.W0086	8	M 4x0,7	8	12	6	2	60	13
35610.W0088	8	M 4x0,7	8	12	6	2	80	20
35610.W0103	10	M 5x0,8	10	12	6	2	35	5
35610.W0106	10	M 5x0,8	10	12	6	2	60	15
35610.W0108	10	M 5x0,8	10	12	6	2	80	40
35610.W0123	12	M 5x0,8	13	12	6	2	35	18
35610.W0126	12	M 5x0,8	13	12	6	2	60	34
35610.W0128	12	M 5x0,8	13	12	6	2	80	86
35610.W0163	16	M 6x1,0	16	12	6	2	35	36
35610.W0166	16	M 6x1,0	16	12	6	2	60	72
35610.W0168	16	M 6x1,0	16	12	6	2	80	117
35610.W0203	20	M 6x1,0	21	12	6	3	35	38
35610.W0206	20	M 6x1,0	21	12	6	3	60	104
35610.W0208	20	M 6x1,0	21	12	6	3	80	165
35610.W0253	25	M 6x1,0	27	12	6	3	35	65
35610.W0256	25	M 6x1,0	27	12	6	3	60	136
35610.W0258	25	M 6x1,0	27	12	6	3	80	272



Grippers - Self Aligning urethane coated - threaded bolt

Grippers & Rest Pads

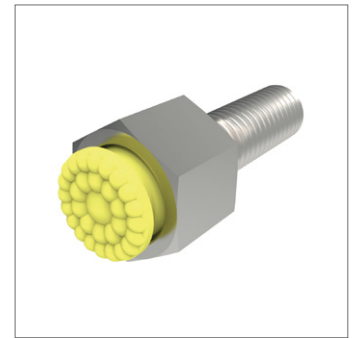
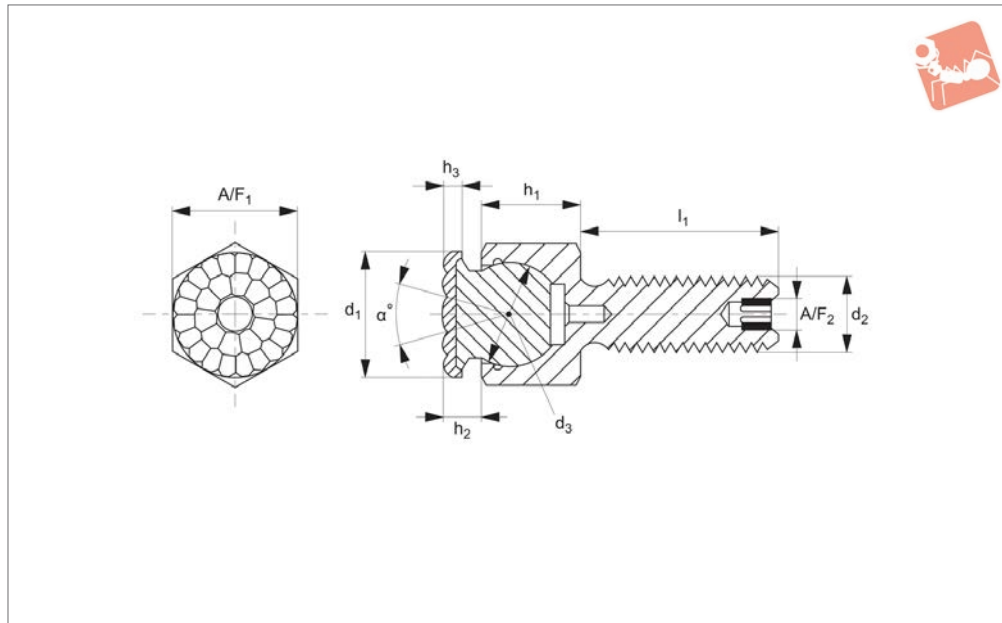

35620

GRIPPERS & REST PADS

Material

Housing body: alloy steel, heat treated to HRC 43-46, black oxide finish.

Pad: urethane, bonded to AISI 300 series stainless steel ball.

Technical Notes

Non-marking, non-staining urethane pad is permanently bonded to the stainless

steel body. Available in three different durometers: 35, 60 & 80 (see table). Bubbled texture of urethane pad allows air to escape so avoiding any suction action.

Tips

Re-seating: expel air by using 0,3 monofilament line between ball and housing, remove line when seated correctly.

Important Notes

Load compression ratings based on load required to compress urethane surface 0,812mm for 2mm thick pad. Compression ratings vary greatly depending upon temperature and other application-specific factors.

Order No.	d ₁	d ₂	l ₁	d ₃	h ₁ ±0.05	h ₂	A/F ₁	A/F ₂	Urethane thickness h ₃	Durometer	Swivel angle α	Load compression kg
35620.W3062	10	M 6x1,0	25	7	8.0	4	10	-	2	35	28	3
35620.W3063	10	M 6x1,0	40	7	8.0	4	10	-	2	35	28	3
35620.W3121	21	M12x1,75	20	15	15.0	6	19	5	2	35	24	68
35620.W6061	10	M 6x1,0	12	7	8.0	4	10	-	2	60	28	11
35620.W6062	10	M 6x1,0	25	7	8.0	4	10	-	2	60	28	11
35620.W6063	10	M 6x1,0	40	7	8.0	4	10	-	2	60	28	11
35620.W6081	13	M 8x1,25	12	10	11.5	5	13	-	2	60	28	34
35620.W6082	13	M 8x1,25	25	10	11.5	5	13	-	2	60	28	34
35620.W6083	13	M 8x1,25	40	10	11.5	5	13	-	2	60	28	34
35620.W6101	16	M10x1,5	15	13	13.0	5	17	3	2	60	28	65
35620.W6102	16	M10x1,5	30	13	13.0	5	17	3	2	60	28	65
35620.W6103	16	M10x1,5	50	13	13.0	5	17	3	2	60	28	65
35620.W6121	21	M12x1,75	20	15	15.0	6	19	5	2	60	24	154
35620.W6122	21	M12x1,75	40	15	15.0	6	19	5	2	60	24	154
35620.W6123	21	M12x1,75	60	15	15.0	6	19	5	2	60	24	154
35620.W6161	23	M16x2,0	25	20	19.0	6	24	6	2	60	24	181
35620.W6162	23	M16x2,0	50	20	19.0	6	24	6	2	60	24	181
35620.W6163	23	M16x2,0	80	20	19.0	6	24	6	2	60	24	181
35620.W8061	10	M 6x1,0	12	7	8.0	4	10	-	2	80	28	29
35620.W8062	10	M 6x1,0	25	7	8.0	4	10	-	2	80	28	29
35620.W8063	10	M 6x1,0	40	7	8.0	4	10	-	2	80	28	29
35620.W8081	13	M 8x1,25	12	10	11.5	5	13	-	2	80	28	68
35620.W8082	13	M 8x1,25	25	10	11.5	5	13	-	2	80	28	68
35620.W8083	13	M 8x1,25	40	10	11.5	5	13	-	2	80	28	68
35620.W8101	16	M10x1,5	15	13	13.0	5	17	3	2	80	28	97
35620.W8102	16	M10x1,5	30	13	13.0	5	17	3	2	80	28	97
35620.W8103	16	M10x1,5	50	13	13.0	5	17	3	2	80	28	97
35620.W8121	21	M12x1,75	20	15	15.0	6	19	5	2	80	24	238
35620.W8122	21	M12x1,75	40	15	15.0	6	19	5	2	80	24	238

Grippers & Rest Pads



Grippers - Self Aligning urethane coated - threaded bolt



Order No.	d ₁	d ₂	l ₁	d ₃	h ₁ ±0.05	h ₂	A/F ₁	A/F ₂	Urethane thickness h ₃	Durometer	Swivel angle a °	Load compression kg
35620.W8123	21	M12x1,75	60	15	15.0	6	19	5	2	80	24	238
35620.W8161	23	M16x2,0	25	20	19.0	6	24	6	2	80	24	272
35620.W8162	23	M16x2,0	0	20	19.0	6	24	6	2	80	24	272
35620.W8163	23	M16x2,0	80	20	19.0	6	24	6	2	80	24	272

GRIPPERS & REST PADS



Grippers - Self Aligning urethane coated - female threaded housing

Grippers & Rest Pads

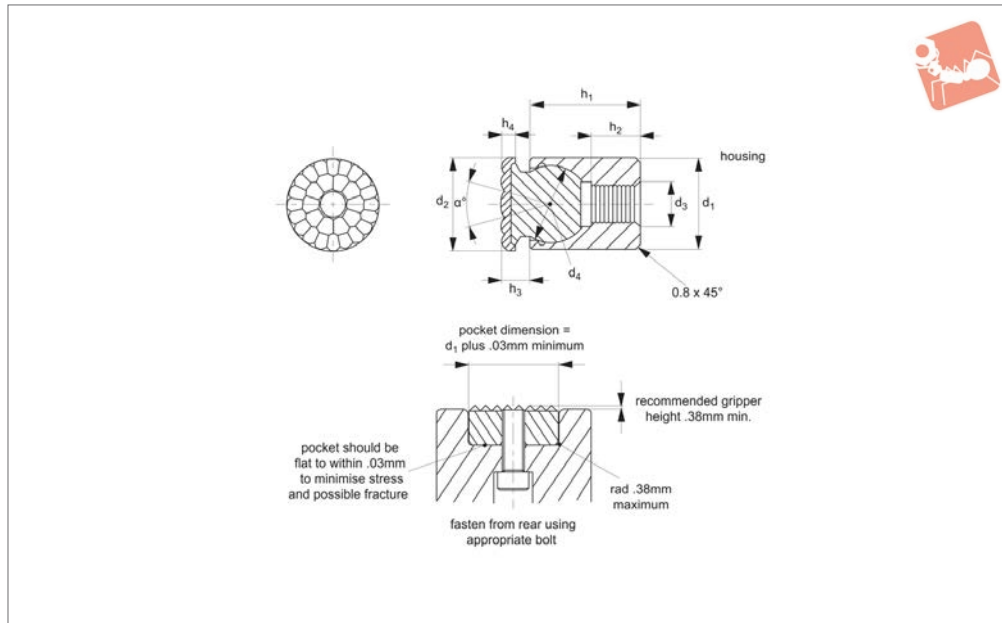

35622

GRIPPERS & REST PADS

Material

Housing body: alloy steel, heat treated to HRC 43-46, black oxide finish.
Pad: urethane, bonded to AISI 300 series stainless steel ball.

Technical Notes

Non-marking, non-staining urethane pad is permanently bonded to the stainless

steel body. Available in three different durometers: 35, 60 & 80 (see table).
Bubbled texture of urethane pad allows air to escape so avoiding any suction action.

Tips

Re-seating: expel air by using 0,3 monofilament line between ball and housing, remove line when seated correctly.

Important Notes

Load compression ratings based on load required to compress urethane surface 0,812mm for 2mm thick pad. Compression ratings vary greatly depending upon temperature and other application-specific factors.

Order No.	d_1 +0.00 -0.13	d_2	d_3	d_4	h_1 ± 0.05	h_2 ± 0.25	h_3	Urethane thickness h_4	Durometer	Swivel angle α	Load compression kg
35622.W3041	10	10	M 4x0,7	7	10.5	3.5	4	2	35	28	3
35622.W3042	10	10	M 4x0,7	7	23.5	9.0	4	2	35	28	3
35622.W3051	13	13	M 5x0,8	10	14.5	6.5	5	2	35	28	18
35622.W3052	13	13	M 5x0,8	10	23.5	9.0	5	2	35	28	18
35622.W3061	17	16	M 6x1,0	13	18.0	7.5	5	2	35	28	24
35622.W3081	19	21	M 8x1,25	15	20.0	8.5	6	2	35	24	68
35622.W3101	24	23	M10x1,5	20	24.0	9.0	6	2	35	24	102
35622.W6041	10	10	M 4x0,7	7	10.5	3.5	4	2	60	28	11
35622.W6042	10	10	M 4x0,7	7	23.5	9.0	4	2	60	28	11
35622.W6051	13	13	M 5x0,8	10	14.5	6.5	5	2	60	28	34
35622.W6052	13	13	M 5x0,8	10	23.5	9.0	5	2	60	28	34
35622.W6061	17	16	M 6x1,0	13	18.0	7.5	5	2	60	28	63
35622.W6081	19	21	M 8x1,25	15	20.0	8.5	6	2	60	24	154
35622.W6101	24	23	M10x1,5	20	24.0	9.0	6	2	60	24	181
35622.W8041	10	10	M 4x0,7	7	10.5	3.5	4	2	80	28	29
35622.W8042	10	10	M 4x0,7	7	23.5	9.0	4	2	80	28	29
35622.W8051	13	13	M 5x0,8	10	14.5	6.5	5	2	80	28	68
35622.W8052	13	13	M 5x0,8	10	23.5	9.0	5	2	80	28	68
35622.W8061	17	16	M 6x1,0	13	18.0	7.5	5	2	80	28	97
35622.W8081	19	21	M 8x1,25	15	20.0	8.5	6	2	80	24	238
35622.W8101	24	23	M10x1,5	20	24.0	9.0	6	2	80	24	272



35624

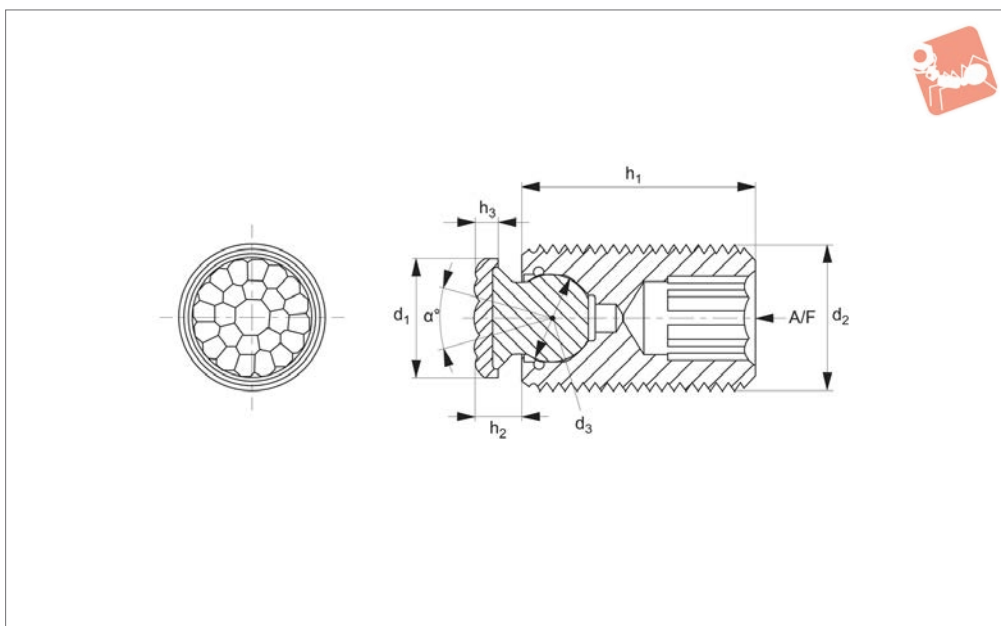

Material

Housing body: alloy steel, heat treated to HRc 43-46, black oxide finish.

Pad: urethane, bonded to AISI 300 series stainless steel ball.

Technical Notes

Available in three different durometers:

35, 60 & 80 (see table).

Bubbled texture of urethane pad allows air to escape so avoiding any suction action.

Tips

Re-seating: expel air by using 0,3 monofilament line between ball and housing, remove line when seated correctly.

Important Notes

Load compression ratings based on load required to compress urethane surface 0,812mm for 2mm thick pad. Compression ratings vary greatly depending upon temperature and other application-specific factors.

Order No.	d ₁	d ₂	d ₃	h ₁	h ₂	h ₃	A/F	Durometer	Swivel angle a	Load compression kg
35624.W6101	8	M10x1,5	5	25	3.5	2	5	60	28	9
35624.W6102	8	M10x1,5	5	35	3.5	2	5	60	28	9
35624.W6103	8	M10x1,5	5	50	3.5	2	5	60	28	9
35624.W6121	10	M12x1,75	7	25	4.0	2	6	60	28	11
35624.W6122	10	M12x1,75	7	35	4.0	2	6	60	28	11
35624.W6123	10	M12x1,75	7	50	4.0	2	6	60	28	11
35624.W6161	13	M16x2,0	10	25	5.0	2	8	60	28	34
35624.W6162	13	M16x2,0	10	35	5.0	2	8	60	28	34
35624.W6163	13	M16x2,0	10	50	5.0	2	8	60	28	34
35624.W6201	16	M20x2,5	13	30	5.0	2	10	60	28	63
35624.W6202	16	M20x2,5	13	50	5.0	2	10	60	28	63
35624.W6203	16	M20x2,5	13	70	5.0	2	10	60	28	63
35624.W6241	21	M24x3,0	15	40	6.0	2	10	60	24	154
35624.W6242	21	M24x3,0	15	80	6.0	2	10	60	24	154
35624.W8101	8	M10x1,5	5	25	3.5	2	5	80	28	18
35624.W8102	8	M10x1,5	5	35	3.5	2	5	80	28	18
35624.W8103	8	M10x1,5	5	50	3.5	2	5	80	28	18
35624.W8121	10	M12x1,75	7	25	4.0	2	6	80	28	29
35624.W8122	10	M12x1,75	7	35	4.0	2	6	80	28	29
35624.W8123	10	M12x1,75	7	50	4.0	2	6	80	28	29
35624.W8161	13	M16x2,0	10	25	5.0	2	8	80	28	68
35624.W8162	13	M16x2,0	10	35	5.0	2	8	80	28	68
35624.W8163	13	M16x2,0	10	50	5.0	2	8	80	28	68
35624.W8201	16	M20x2,5	13	30	5.0	2	10	80	28	97
35624.W8202	16	M20x2,5	13	50	5.0	2	10	80	28	97
35624.W8203	16	M20x2,5	13	70	5.0	2	10	80	28	97
35624.W8241	21	M24x3,0	15	40	6.0	2	10	80	24	238
35624.W8242	21	M24x3,0	15	80	6.0	2	10	80	24	238

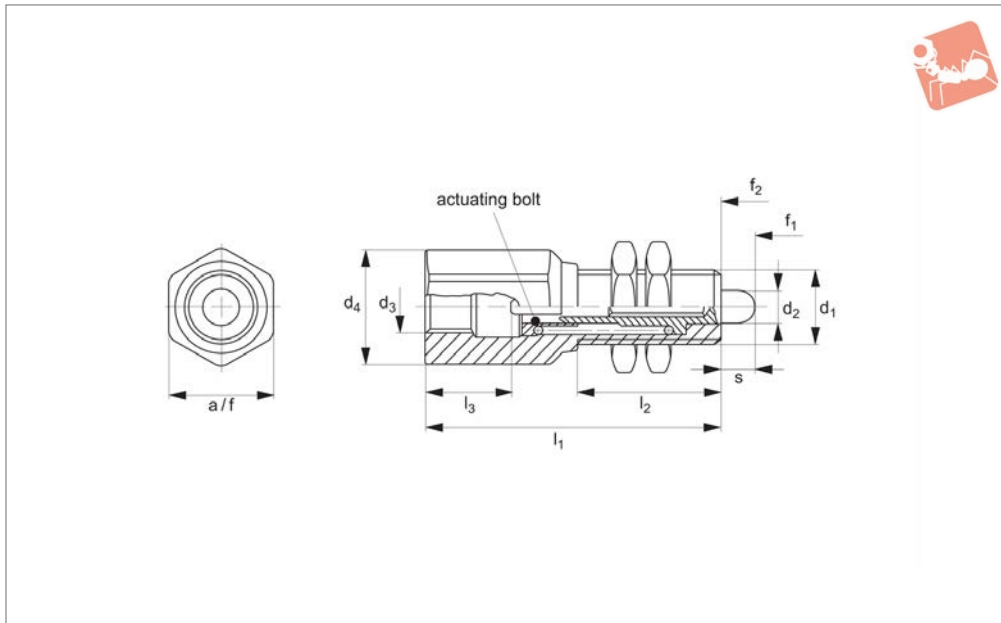

38700

Material

Housing: stainless steel 1.4305
 Spring: stainless steel
 Pin: stainless steel 1.4305
 Nut: (ISO 4035), nickle plated.

Technical Notes

Spring plunger with integrated position

sensing via standard inductive sensors.
 Adjustment of the sensor screw enables variation of the switching range. Sensitivity of switch can be adjusted throughout the entire stroke. Suitable for inductive sensors with flush contact. Spring loads * = statistical average value.

Tips

Suitable for multiple applications, e.g. position control.

Order No.	d ₁	d ₂	d ₃	d ₄	l ₁	l ₂	l ₃ ≈	s	A/F	Spring load F ₁ N ≈	Spring load F ₂ N ≈	Weight g
38700.W0012	M12x1	6.2	M_8x1	19.0	44	20	15.5	5.6	17	24.0	47.3	57
38700.W0016	M16x1	8.5	M12x1	21.5	65	32	20.0	7.5	19	32.5	65.5	103

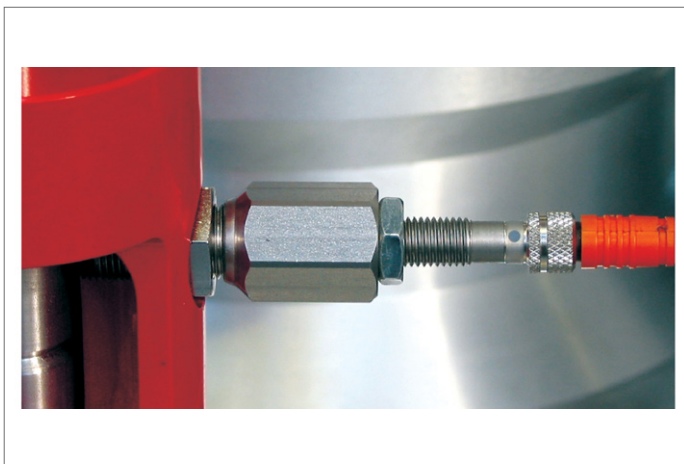



38720

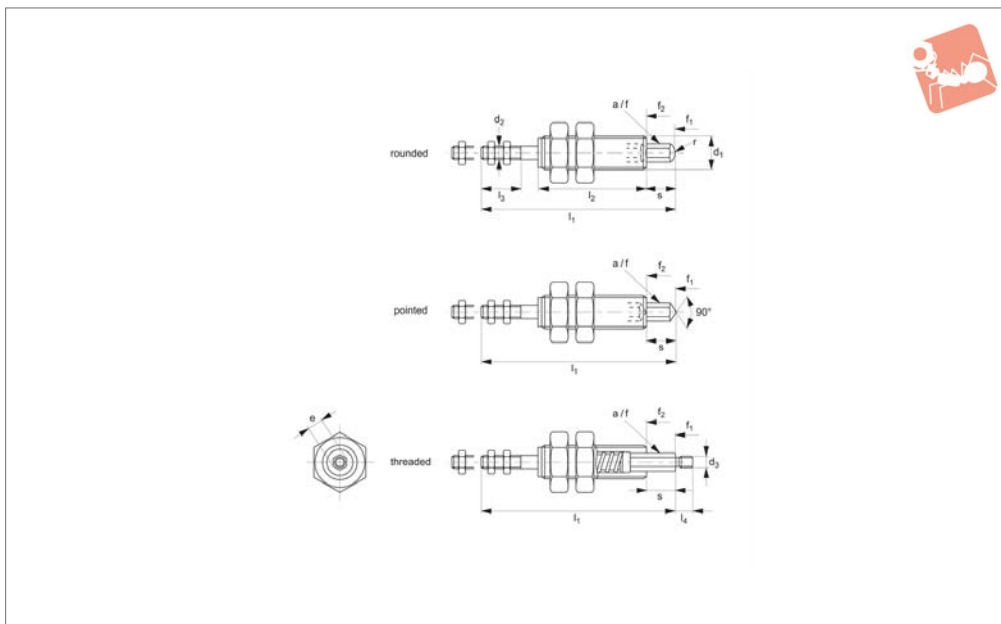

Material

Bolt: steel, nitrided, black.
 Nut: steel, quality 8.8, blackened (ISO 4035).
 Actuating bolt: nitrided, black.
 Spring: stainless steel.

Technical Notes

Spring plunger with position sensing by

means of an actuating bolt (protected against turning). Threaded tip allows for fitting of special purpose adapters. A switching element can be fitted to the fastening thread of the actuating bolt, most commonly used switches are suitable. Spring loads * = statistical average values.

Tips

Suitable for multiple applications, e.g. as lift-off pin in tools with position control.

Order No.	Type	d ₁	d ₂	d ₃	e ≈	l ₁	l ₂	l ₃ min.	l ₄	R	s	A/F	Spring load F ₁ N ≈	Spring load F ₂ N ≈	Weight g
38720.W0008	Rounded Tip	M 8	M2,5	-	3.5	50	32	9	-	1.75	6	3	4.1	7.6	15
38720.W0010	Rounded Tip	M10	M 3	-	4.6	59	35	11	-	2.30	8	4	5.0	9.0	28
38720.W0012	Rounded Tip	M12	M 4	-	5.8	68	38	14	-	2.90	10	5	5.1	11.0	44
38720.W0016	Rounded Tip	M16	M 5	-	6.9	78	42	16	-	3.50	12	6	7.5	13.8	87
38720.W0058	Pointed Tip	M 8	M2,5	-	3.5	50	32	9	-	-	6	3	4.1	7.6	14
38720.W0060	Pointed Tip	M10	M 3	-	4.6	59	35	11	-	-	8	4	5.0	9.0	29
38720.W0062	Pointed Tip	M12	M 4	-	5.8	68	38	14	-	-	10	5	5.1	11.0	44
38720.W0066	Pointed Tip	M16	M 5	-	6.9	78	42	16	-	-	12	6	7.5	13.8	88
38720.W0108	Threaded Tip	M 8	M2,5	M2,5	3.5	50	32	9	4	-	6	3	4.1	7.6	15
38720.W0110	Threaded Tip	M10	M 3	M 3	4.6	59	35	11	5	-	8	4	5.0	9.0	29
38720.W0112	Threaded Tip	M12	M 4	M 4	5.8	68	38	14	6	-	10	5	5.1	11.0	44
38720.W0116	Threaded Tip	M16	M 5	M 5	6.9	78	42	16	7	-	12	6	7.5	13.8	89

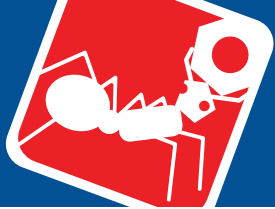

Sensing Elements

with actuating bolt, protected against rotating



Sensing Elements



SENSING ELEMENTS



33400

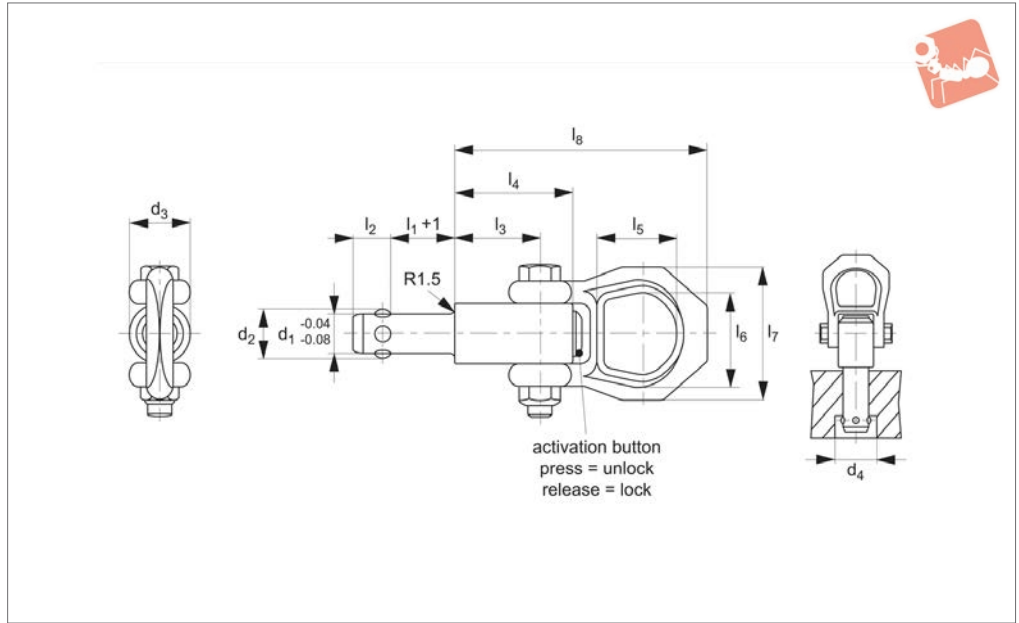

Material

Pin, Body & Shackle: heat treated steel, tempered, manganese phosphated.
 Actuation Button: aluminium, red anodised.
 Spring: stainless steel.

Technical Notes

Pressing = unlocking.
 Releasing = locking.
 Lifts forces up to 4.8kN (with a 5 fold in-built safety factor).

Temperature range up to +250°C.

Easy installation with plain drilled hole to H11 tolerance.

Tips

The design of the safety shackle prevents accidental locking/unlocking. Safety shackle is adjustable and can be used to lift components at 90°, 45° or 180°.

Important Notes

* are values calculated on a 5-fold safety

against breakage.

When machining receiving hole in aluminium we recommend use of hardened bush or collar in receiving hole, see our part no. 33440.

Supplied with TUV test certificate of manufacturing process. Parts not individually tested.

Order No.	l_1	d_1 -0.04 -0.08	d_2	d_3	d_4 min.	l_2	l_3	l_4	l_5	Weight g
33400.W0601	10	8.0	9.35	21.5	9.85	8.75	25.7	36.0	27.0	218
33400.W0602	15	8.0	9.35	21.5	9.85	8.75	25.7	36.0	27.0	220
33400.W0604	25	8.0	9.35	21.5	9.85	8.75	25.7	36.0	27.0	223
33400.W0606	35	8.0	9.35	21.5	9.85	8.75	25.7	36.0	27.0	226
33400.W0611	10	8.3	9.65	21.5	10.05	8.75	25.7	36.0	27.0	218
33400.W0612	15	8.3	9.65	21.5	10.05	8.75	25.7	36.0	27.0	219
33400.W0614	25	8.3	9.65	21.5	10.05	8.75	25.7	36.0	27.0	223
33400.W0616	35	8.3	9.65	21.5	10.05	8.75	25.7	36.0	27.0	228
33400.W0621	15	10.0	11.70	21.5	12.20	10.20	25.7	36.0	27.0	226
33400.W0623	25	10.0	11.70	21.5	12.20	10.20	25.7	36.0	27.0	238
33400.W0625	35	10.0	11.70	21.5	12.20	10.20	25.7	36.0	27.0	244
33400.W0627	50	10.0	11.70	21.5	12.20	10.20	25.7	36.0	27.0	252
33400.W0631	15	12.0	14.20	21.5	14.70	11.00	25.7	36.0	27.0	238
33400.W0633	25	12.0	14.20	21.5	14.70	11.00	25.7	36.0	27.0	243
33400.W0635	35	12.0	14.20	21.5	14.70	11.00	25.7	36.0	27.0	251
33400.W0637	50	12.0	14.20	21.5	14.70	11.00	25.7	36.0	27.0	268
33400.W0651	25	13.8	16.20	21.5	16.70	13.00	25.7	36.0	27.0	251
33400.W0653	50	13.8	16.20	21.5	16.70	13.00	25.7	36.0	27.0	279
33400.W0655	75	13.8	16.20	21.5	16.70	13.00	25.7	36.0	27.0	309
33400.W0641	25	16.0	18.60	25.0	19.20	15.10	31.0	44.5	27.0	312
33400.W0643	50	16.0	18.60	25.0	19.20	15.10	31.0	44.5	27.0	353
33400.W0645	75	16.0	18.60	25.0	19.20	15.10	31.0	44.5	27.0	388
33400.W0673	50	20.0	24.50	30.0	25.00	19.70	36.5	52.0	32.6	607
33400.W0675	75	20.0	24.50	30.0	25.00	19.70	36.5	52.0	32.6	666



Order No.	l_6	l_7	l_8	F_1 kN	F_2 kN	F_3 kN	x min.	x max.	Location hole tol. H11
33400.W0601	30	49	87.5	1.5	1.2	0.5	1.5	5	8.0
33400.W0602	30	49	87.5	1.5	1.2	0.5	1.5	10	8.0
33400.W0604	30	49	87.5	1.5	1.2	0.5	1.5	15	8.0
33400.W0606	30	49	87.5	1.5	1.2	0.5	1.5	15	8.0
33400.W0611	30	49	87.5	1.5	1.2	0.5	1.5	5	8.3
33400.W0612	30	49	87.5	1.5	1.2	0.5	1.5	10	8.3
33400.W0614	30	49	87.5	1.5	1.2	0.5	1.5	15	8.3
33400.W0616	30	49	87.5	1.5	1.2	0.5	1.5	15	8.3
33400.W0621	30	49	87.5	2.7	2.4	2.1	1.5	10	10.0
33400.W0623	30	49	87.5	2.7	2.4	2.1	1.5	10	10.0
33400.W0625	30	49	87.5	2.7	2.4	2.1	1.5	10	10.0
33400.W0627	30	49	87.5	2.7	2.4	2.1	1.5	10	10.0
33400.W0631	30	49	87.5	3.5	3.2	2.8	1.5	10	12.0
33400.W0633	30	49	87.5	3.5	3.2	2.8	1.5	15	12.0
33400.W0635	30	49	87.5	3.5	3.2	2.8	1.5	15	12.0
33400.W0637	30	49	87.5	3.5	3.2	2.8	1.5	15	12.0
33400.W0651	30	49	87.5	3.8	3.5	2.8	1.5	15	13.8
33400.W0653	30	49	87.5	3.8	3.5	2.8	1.5	35	13.8
33400.W0655	30	49	87.5	3.8	3.5	2.8	1.5	35	13.8
33400.W0641	30	49	92.8	4.8	4.5	4.1	1.5	15	16.0
33400.W0643	30	49	92.8	4.8	4.5	4.1	1.5	35	16.0
33400.W0645	30	49	92.8	4.8	4.5	4.1	1.5	40	16.0
33400.W0673	36	56	114	10.0	8.5	6.5	1.5	25	20.0
33400.W0675	36	56	114	10.0	8.5	6.5	1.5	25	20.0

QUICK LIFT PINS

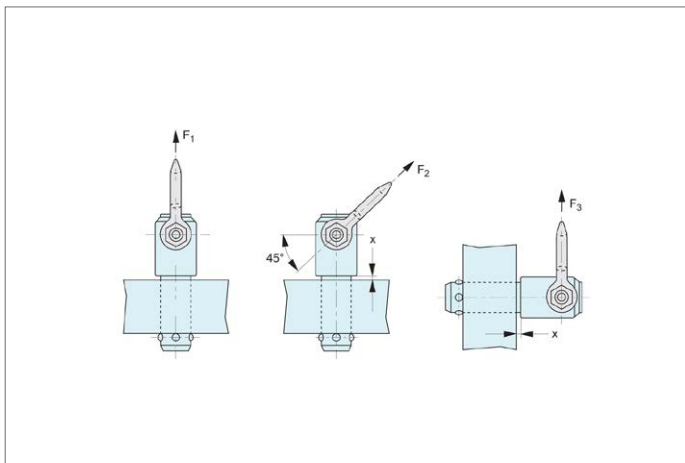



33420

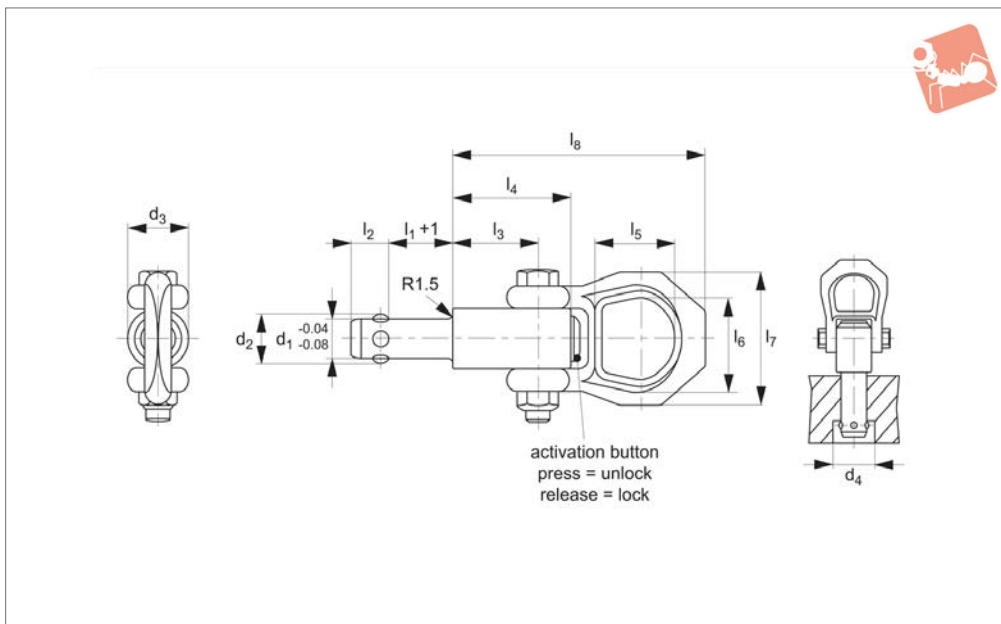

Material

Pin & Body: stainless steel 1.4542 (AISI 630), precipitation hardened.
 Shackle: stainless steel 1.4571.
 Actuation Button: aluminium, red anodised.
 Spring: stainless steel.

Technical Notes

Pressing = unlocking.
 Releasing = locking.
 Lifts forces up to 4.8kN (with a 5 fold in-

built safety factor).

Temperature range up to +250°C.
 Easy installation with plain drilled hole to H11 tolerance.
 Corrosion and weather resistant, therefore suitable for outdoor applications.

Tips

The design of the safety shackle prevents accidental locking/unlocking. Safety shackle is adjustable and can be used to lift components at 90°, 45° or 180°.

Important Notes

* are values calculated on a 5-fold safety against breakage.
 When machining receiving hole in aluminium we recommend use of hardened bush or collar in receiving hole, see our part no. 33440.
Supplied with TUV test certificate of manufacturing process. Parts not individually tested.

Order No.	l_1	d_1	d_2	d_3	d_4 min.	l_2	l_3	l_4	l_5	Weight g
33420.W0701	10	8.0	9.35	21.5	9.85	8.75	25.7	36.0	27	221
33420.W0702	15	8.0	9.35	21.5	9.85	8.75	25.7	36.0	27	222
33420.W0704	25	8.0	9.35	21.5	9.85	8.75	25.7	36.0	27	225
33420.W0706	35	8.0	9.35	21.5	9.85	8.75	25.7	36.0	27	229
33420.W0711	10	8.3	9.65	21.5	10.05	8.75	25.7	36.0	27	222
33420.W0712	15	8.3	9.65	21.5	10.05	8.75	25.7	36.0	27	223
33420.W0714	25	8.3	9.65	21.5	10.05	8.75	25.7	36.0	27	225
33420.W0716	35	8.3	9.65	21.5	10.05	8.75	25.7	36.0	27	231
33420.W0721	15	10.0	11.70	21.5	12.20	10.20	25.7	36.0	27	233
33420.W0723	25	10.0	11.70	21.5	12.20	10.20	25.7	36.0	27	243
33420.W0725	35	10.0	11.70	21.5	12.20	10.20	25.7	36.0	27	250
33420.W0727	50	10.0	11.70	21.5	12.20	10.20	25.7	36.0	27	257
33420.W0731	15	12.0	14.20	21.5	14.70	11.00	25.7	36.0	27	246
33420.W0733	25	12.0	14.20	21.5	14.70	11.00	25.7	36.0	27	255
33420.W0735	35	12.0	14.20	21.5	14.70	11.00	25.7	36.0	27	265
33420.W0737	50	12.0	14.20	21.5	14.70	11.00	25.7	36.0	27	273
33420.W0751	25	13.8	16.20	21.5	16.70	13.00	25.7	36.0	27	255
33420.W0753	50	13.8	16.20	21.5	16.70	13.00	25.7	36.0	27	283
33420.W0755	75	13.8	16.20	21.5	16.70	13.00	25.7	36.0	27	311
33420.W0741	25	16.0	18.60	25.0	19.20	15.10	31.0	44.5	27	313
33420.W0743	50	16.0	18.60	25.0	19.20	15.10	31.0	44.5	27	367
33420.W0745	75	16.0	18.60	25.0	19.20	15.10	31.0	44.5	27	403
33420.W0773	50	20.0	24.50	30.0	25.00	19.70	36.5	52.0	32.6	607
33420.W0775	75	20.0	24.50	30.0	25.00	19.70	36.5	52.0	32.6	666



Quick Lift Pins - Self Locking stainless steel



Order No.	l_6	l_7	l_8	F_1 kN	F_2 kN	F_3 kN	x min.	x max.	Location hole dia. tol. H11
33420.W0701	30	49	87.5	1.5	1.2	0.5	1.5	5	8.0
33420.W0702	30	49	87.5	1.5	1.2	0.5	1.5	10	8.0
33420.W0704	30	49	87.5	1.5	1.2	0.5	1.5	15	8.0
33420.W0706	30	49	87.5	1.5	1.2	0.5	1.5	15	8.0
33420.W0711	30	49	87.5	1.5	1.2	0.5	1.5	5	8.3
33420.W0712	30	49	87.5	1.5	1.2	0.5	1.5	10	8.3
33420.W0714	30	49	87.5	1.5	1.2	0.5	1.5	15	8.3
33420.W0716	30	49	87.5	1.5	1.2	0.5	1.5	15	8.3
33420.W0721	30	49	87.5	2.7	2.4	2.1	1.5	10	10.0
33420.W0723	30	49	87.5	2.7	2.4	2.1	1.5	10	10.0
33420.W0725	30	49	87.5	2.7	2.4	2.1	1.5	10	10.0
33420.W0727	30	49	87.5	2.7	2.4	2.1	1.5	10	10.0
33420.W0731	30	49	87.5	3.5	3.2	2.8	1.5	10	12.0
33420.W0733	30	49	87.5	3.5	3.2	2.8	1.5	15	12.0
33420.W0735	30	49	87.5	3.5	3.2	2.8	1.5	15	12.0
33420.W0737	30	49	87.5	3.5	3.2	2.8	1.5	15	12.0
33420.W0751	30	49	87.5	3.8	3.5	2.8	1.5	15	13.8
33420.W0753	30	49	87.5	3.8	3.5	2.8	1.5	35	13.8
33420.W0755	30	49	87.5	3.8	3.5	2.8	1.5	35	13.8
33420.W0741	30	49	92.8	4.8	4.5	4.1	1.5	15	16.0
33420.W0743	30	49	92.8	4.8	4.5	4.1	1.5	35	16.0
33420.W0745	30	49	92.8	4.8	4.5	4.1	1.5	40	16.0
33420.W0773	36	56	114.0	10.0	8.5	6.5	1.5	25	20.0
33420.W0775	36	56	114.0	10.0	8.5	6.5	1.5	30	20.0

QUICK LIFT PINS

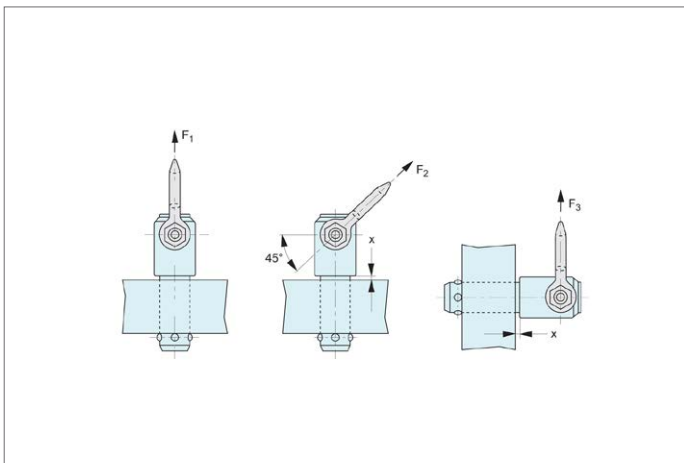



Danger!

Self-locking quick lift pins are designed to lift and hold point loads not people.

Self-locking quick lift pins are not suited for rotating loads.

Dirt and debris etc can affect the performance of the pins.

Using damaged self-locking pins can be very dangerous. Before each use carefully inspect the pins (damage, deformities, signs of stress, corrosion, check unlocking and locking function, loss of balls etc. Check full movement of shackle. Withdraw any defective pins from service immediately.

To release the balls, press button A. To lock the balls, release button A.

The load figures F_1 , F_2 and F_3 apply only to lifting applications used with a steel retainer, and an "x" min of 1.5mm.

Inspect before and after every use. For maintenance – take the out of service after 12 months for inspection by qualified personnel.

Operating Instructions 33400 and 33420

Note: The full shaft must be engaged. Longer shaft lengths can be supplied on request or a bolt and washer/nut combination can be used.

- Ensure all lifting pins are CE marked.
- Ensure they are handled by qualified personnel.
- Refer to the operating instructions particularly with regards to product selection, any possibility of the load swivelling, the effect of lifting angles on the load capacity (see relevant tables), etc.
- Never allow any personnel underneath a suspended load.
- Always heed the load rating of the lifting pin.
- Always perform a visual inspection of the lifting pins prior to use. Checking for any damage to thread and/or swivelling system. Check for wear or corrosion, signs of stress or bending.
- Ensure a yearly full service inspection is performed.
- Always ensure the full bottom face of the lifting pin shoulder is in contact with a smooth, square surface.
- Ensure full and unrestricted movement of the lifting pin in all directions.
- Before each lift ensure the correct orientation of the shackle in the lift direction.
- Avoid using our standard steel lifting pins in corrosive environments eg. sandy, chemical, acid, moisture etc. In this case consider using our stainless steel lifting pins (33420).

Notes

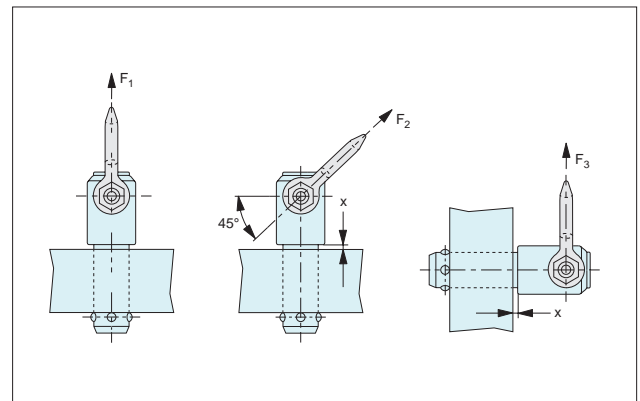
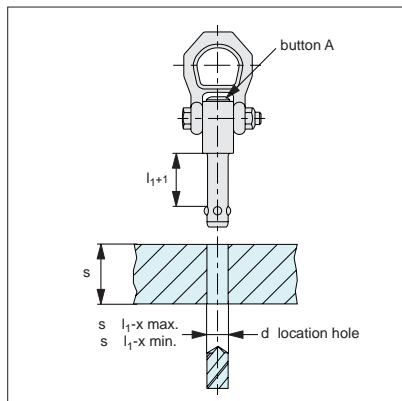



Quick Lift Pins - Threaded

double swivel - metric

Quick Lift Pins

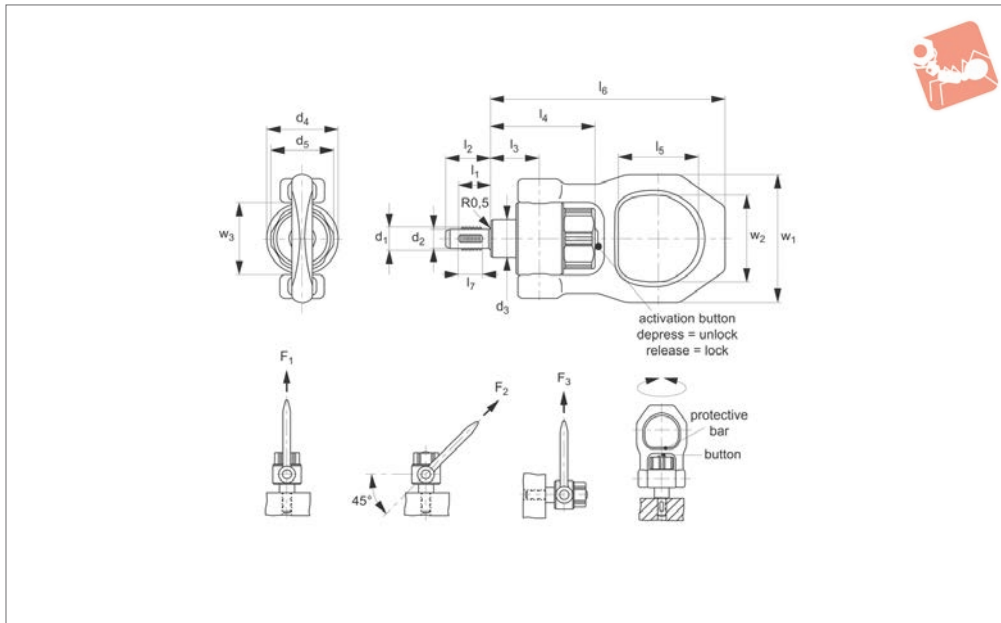

33425

QUICK LIFT PINS

Material

Steel

Pin: heat-treated steel, tempered, manganese phosphated.
 Threaded element: stainless steel 1.4542, (AISI 630) precipitation hardened.
 Shackle: steel, heat-treated, tempered, manganese phosphated.
 Press button: aluminium, orange anodised.
 Spring: stainless steel.

Stainless steel

Pin: stainless steel 1.4542, (AISI 630) precipitation hardened.
 Threaded element: stainless steel 1.4542, (AISI 630) precipitation hardened.
 Shackle: stainless steel 1.45471.

Press button: aluminium, orange anodised.
 Spring: stainless Steel.

Technical Notes

To suit metric coarse threads, tolerance g6. CE marked. Both types are corrosion protected. The stainless steel pin is resistant to corrosion and weathering, so suitable for external use. The instruction manual and CE Declaration of Conformity are included. F_1^* and F_3^* values are inscribed on the body for reference. F values are calculated on 5 x safety factor. Depress button: to unlock. Release button: to lock. Max temp. 250°C.

Tips

Heavy duty lifting pin, quick and easy to use with pivoting shackle and protective bar to prevent unintentional unlocking. The threaded lifting pin is inserted into a threaded hole, so no time is wasted screwing in and out alternative lifting rings. The rotatable shackle will always align with the tensile direction of pull without the pin rotating. This prevents the load-handling device from being turned out of the thread and the component can be lifted safely.

Before use: read instruction manual, and data sheets follow standard safe lifting procedures.

Order No.	Type	l_1	d_1	d_2 -0.07	d_3	d_4	d_5	l_2	l_3	l_4	l_5	Weight g
33425.W0010	Steel	14	M10	8.4	20	38	33.5	20.0	25.7	54.9	42.5	581
33425.W0012	Steel	17	M12	10.1	20	38	33.5	24.0	25.7	54.9	42.5	585
33425.W0016	Steel	17	M16	13.8	20	38	33.5	24.0	25.7	54.9	42.5	597
33425.W0020	Steel	22	M20	17.3	35	56	50.0	30.0	36.5	73.7	55.6	1789
33425.W0024	Steel	27	M24	20.7	35	56	50.0	36.0	42.0	79.2	55.6	1864
33425.W1010	Stainless Steel	14	M10	8.4	20	38	33.5	20.0	25.7	54.9	42.5	581
33425.W1012	Stainless Steel	17	M12	10.1	20	38	33.5	24.0	25.7	54.9	42.5	585
33425.W1016	Stainless Steel	17	M16	13.8	20	38	33.5	24.0	25.7	54.9	42.5	597
33425.W1020	Stainless Steel	22	M20	17.3	35	56	50.0	30.0	36.5	73.7	55.6	1789
33425.W1024	Stainless Steel	27	M24	20.7	35	56	50.0	36.0	42.0	79.2	55.6	1864

Order No.	l_6	l_7	w_1	w_2	w_3	F_1 kN	F_2 kN	F_3 kN	Locating thread	Tightening torque Nm max.
33425.W0010	123.7	10	68	46	38	3.9	1.5	1.5	M10	2
33425.W0012	123.7	12	68	46	38	6.2	2.5	2.3	M12	2
33425.W0016	123.7	12	68	46	38	8.4	4.5	4.2	M16	2
33425.W0020	167.5	17	102	70	59	16.6	7.7	5.0	M20	3
33425.W0024	173.0	22	102	70	59	18.5	11.1	8.6	M24	3



Order No.	l_6	l_7	w_1	w_2	w_3	F_1 kN	F_2 kN	F_3 kN	Locating thread	Tightening torque Nm max.
33425.W1010	123.7	10	68	46	38	3.9	1.5	1.5	M10	2
33425.W1012	123.7	12	68	46	38	6.2	2.5	2.3	M12	2
33425.W1016	123.7	12	68	46	38	8.4	4.5	4.2	M16	2
33425.W1020	167.5	17	102	70	59	16.6	7.7	5.0	M20	3
33425.W1024	173.0	22	102	70	59	18.0	11.1	8.6	M24	3

QUICK LIFT PINS

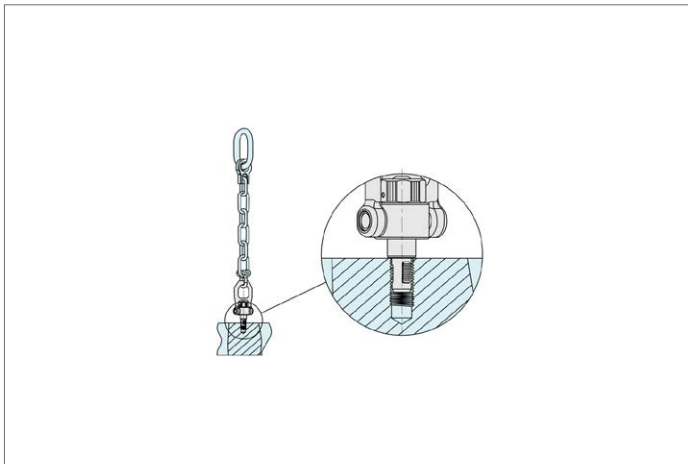



Quick Lift Pins - Threaded

double swivel - inch

Quick Lift Pins

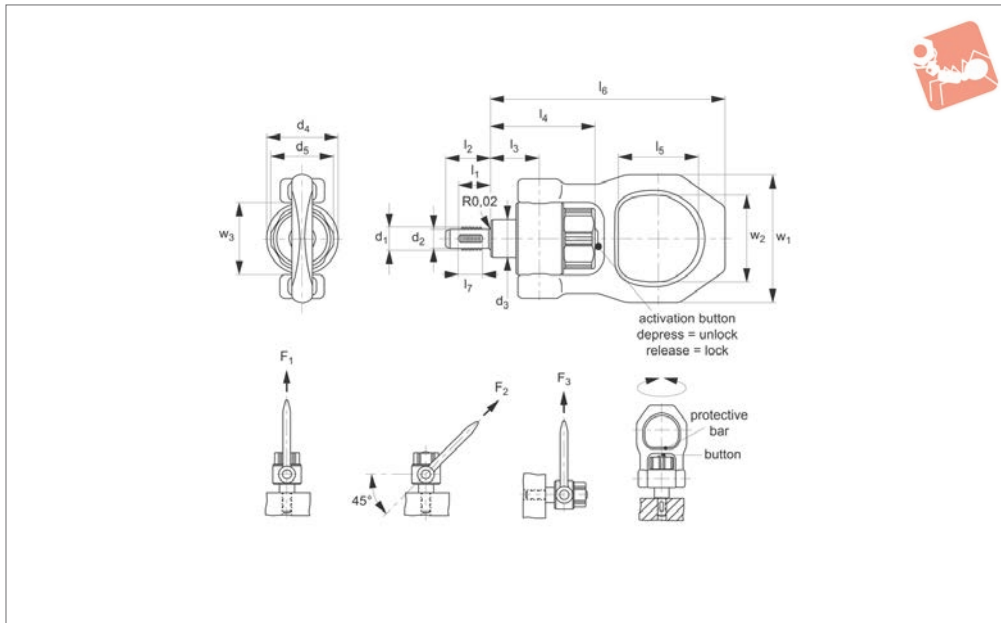

3B425

QUICK LIFT PINS

Material

Steel:

Pin: heat-treated steel, tempered, manganese phosphated.
 Threaded element: stainless steel 1.4542, (AISI 630) precipitation hardened.
 Shackle: steel, heat-treated, tempered, manganese phosphated.
 Press button: aluminium, orange anodised.
 Spring: stainless steel.

Stainless steel:

Pin: stainless steel 1.4542, (AISI 630) precipitation hardened.
 Threaded element: stainless steel 1.4542, (AISI 630) precipitation hardened.
 Shackle: stainless steel 1.45471.
 Press button: aluminium, orange anodised.

Spring: stainless steel.

Technical Notes

To suit inch coarse threads, tolerance g6. CE marked. Both types are corrosion protected. The stainless steel pin is resistant to corrosion and weathering, so suitable for external use. The instruction manual and CE Declaration of Conformity are included. F_1^* and F_3^* values are inscribed on the body for reference. F values are calculated on 5 x safety factor. Depress button: to unlock. Release button: to lock. Max temp. 482°F 250°C.

Tips

Heavy duty lifting pin, quick and easy to

use with pivoting, rotatable shackle and protective bar to prevent unintentional unlocking. The threaded lifting pin is inserted into a threaded hole, so no time is wasted screwing in and out alternative lifting rings. The rotatable shackle will always align with the tensile direction of pull without the pin rotating. This prevents the load-handling device from being turned out of the thread and the component can be lifted safely.

Before use: read instruction manual, and data sheets follow standard safe lifting procedures.

Dimensions in inches.

Order No.	Type	l_1	d_1	d_2 inch +0.0028	d_3	d_4	d_5	l_2	l_3	Weight lb
3B425.W0012	Steel	0.669	1/2"-13	0.416	0.787	1496	1.319	0.945	1.012	1.29
3B425.W0020	Steel	0.866	3/4"-10	0.640	1.378	2323	1.969	1.181	1.437	3.93
3B425.W0024	Steel	1.063	1"-8	0.863	1.378	2323	1.969	1.417	1.654	4.13
3B425.W1012	Stainless Steel	0.669	1/2"-13	0.416	0.790	1496	1.320	0.945	1.012	1.29
3B425.W1020	Stainless Steel	0.866	3/4"-10	0.640	1.378	2323	1.969	1.181	1.437	3.93
3B425.W1024	Stainless Steel	1.063	1"-8	0.863	1.378	2323	1.969	1.417	1.654	4.13

Order No.	l_4	l_5	l_6	l_7	w_1	w_2	w_3	F_1 lbf	F_2 lbf	F_3 lbf	Locating thread	Tightening torque Nm max.
3B425.W0012	2.161	1.673	4.870	0.472	2.677	1.811	1.496	1528	764	607	1/2"-13	1.48
3B425.W0020	2.902	2.189	6.594	0.669	4.016	2.756	2.323	3619	1731	1124	3/4"-10	2.21
3B425.W0024	3.118	2.189	6.811	0.866	4.016	2.756	2.323	4159	3147	2225	1"-8	2.21
3B425.W1012	2.161	1.673	4.870	0.472	2.677	1.811	1.496	1528	764	607	1/2"-13	1.48
3B425.W1020	2.902	2.189	6.594	0.669	4.016	2.756	2.323	3619	1731	1124	3/4"-10	2.21
3B425.W1024	3.118	2.189	6.811	0.866	4.016	2.756	2.323	4046	3147	2225	1"-8	2.21

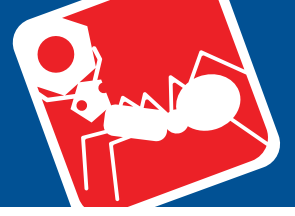

QUICK LIFT PINS

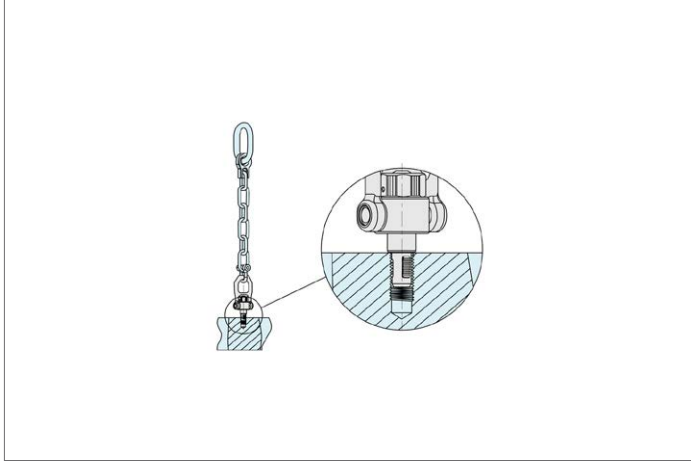



Quick Lift Pins - Threaded metric

Quick Lift Pins

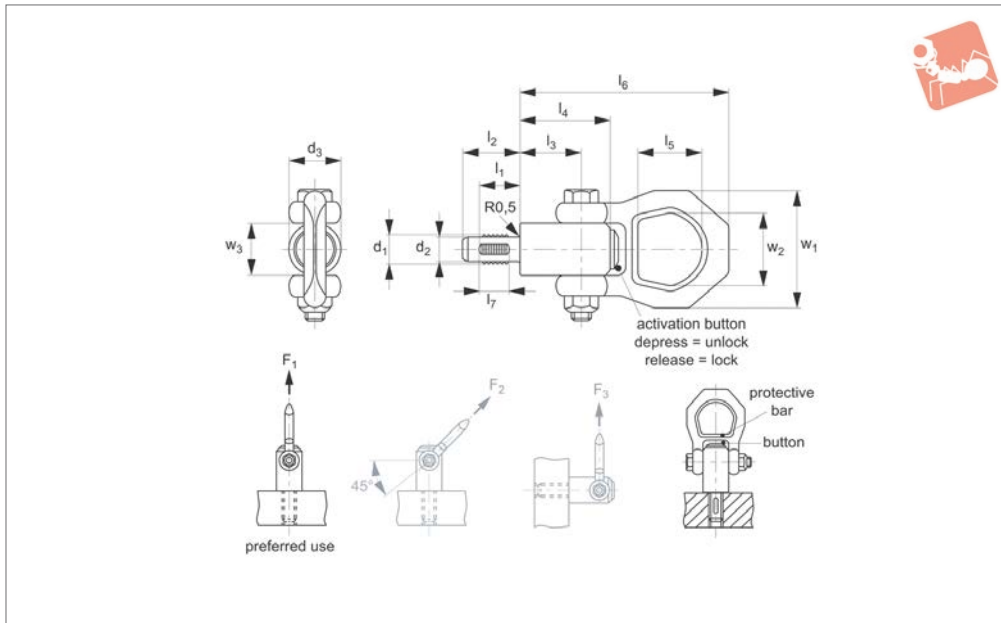

33430

QUICK LIFT PINS

Material

Steel:

Pin: heat-treated steel, tempered, manganese phosphated.
 Threaded element: stainless steel 1.4542, (AISI 630) precipitation hardened.
 Shackle: steel, heat-treated, tempered, manganese phosphated.
 Press button: aluminium, orange anodised.
 Spring: stainless steel.

Stainless steel:

Pin: stainless steel 1.4542, (AISI 630) precipitation hardened.
 Threaded element: stainless steel 1.4542, (AISI 630) precipitation hardened.
 Shackle: stainless steel 1.45471.
 Press button: aluminium, orange anodised.
 Spring: stainless steel.

Technical Notes

To suit metric coarse threads, tolerance g6.

CE marked. Both types are corrosion protected. The stainless steel pin is resistant to corrosion and weathering, so suitable for external use.

The instruction manual and CE Declaration of Conformity are included.

F_1^* and F_3^* values are inscribed on the body for reference. F values are calculated on 5 x safety factor.

Depress button: to unlock.

Release button: to lock.

Max temp. 250°C.

Tips

The pin is ideally used for single point straight up lifts. The bottom face of the pin must be in full contact with the part to be lifted. The pin can also be used with forces F_2 and F_3 after ensuring that the shackle direction is aligned to the direction of the pull. The preferred part for these types of lifts is part 33425, which has a double

swivel function.

Before use: read instruction manual, and data sheets follow standard safe lifting procedures.

Important Notes

The threaded pin must be completely screwed into the thread and tightened to specified tightening torque and bear completely on the bearing surface. Quick and easy to use. The shackle pivots. The protective bar prevents unintentional unlocking by a hook or similar.

Use recommended mainly for direct upwards lift (F_1) as the shackle should be aligned to the direction of lift. Other pins (33425) have a swivel bearing to align shackle.

Rotation of loads must be prevented.

Order No.	Type	l_1	d_1	d_2 -0.07	d_3	l_2	l_3	l_4	l_5	Weight g
33430.W0008	Steel	12	M 8	6.6	21.5	17.8	25.7	36	27.0	228
33430.W0010	Steel	14	M10	8.4	21.5	20.0	25.7	36	27.0	271
33430.W0012	Steel	17	M12	10.1	21.5	24.0	25.7	36	27.0	234
33430.W0014	Steel	17	M14	11.8	21.5	24.0	25.7	36	27.0	280
33430.W0016	Steel	17	M16	13.8	21.5	24.0	25.7	36	27.0	244
33430.W0020	Steel	22	M20	17.3	30.0	30.0	36.5	52	32.6	518
33430.W0024	Steel	27	M24	20.7	36.0	30.6	42.0	60	50.6	1187
33430.W0027	Steel	31	M27	23.7	45.0	40.0	42.0	60	50.6	1420
33430.W0030	Steel	35	M30	26.1	45.0	45.0	42.0	60	50.6	1468
33430.W1008	Stainless Steel	12	M 8	6.6	21.5	17.8	25.7	36	27.0	228
33430.W1010	Stainless Steel	14	M10	8.4	21.5	20.0	25.7	36	27.0	229
33430.W1012	Stainless Steel	17	M12	10.1	21.5	24.0	25.7	36	27.0	237
33430.W1016	Stainless Steel	17	M16	13.8	21.5	24.0	25.7	36	27.0	247



Order No.	Type	l_1	d_1	d_2 -0.07	d_3	l_2	l_3	l_4	l_5	Weight g
33430.W1020	Stainless Steel	22	M20	17.3	30.0	30.0	36.5	52	32.6	519
33430.W1024	Stainless Steel	27	M24	20.7	36.0	30.6	42.0	60	50.6	1219

Order No.	l_6	l_7	w_1	w_2	w_3	F_1 kN	F_2 kN	F_3 kN	Locating thread
33430.W0008	87.5	8	49	30.0	21.5	2.1	0.9	0.8	M 8
33430.W0010	87.5	10	49	30.0	21.5	3.9	1.5	1.5	M10
33430.W0012	87.5	12	49	30.0	21.5	6.2	2.5	2.3	M12
33430.W0014	87.5	12	49	30.0	21.5	7.8	4.2	2.9	M14
33430.W0016	87.5	12	49	30.0	21.5	8.4	4.5	4.2	M16
33430.W0020	114.0	17	56	36.0	30.0	16.6	7.7	5.8	M20
33430.W0024	152.0	22	82	49.8	36.0	23.0	11.1	8.6	M24
33430.W0027	152.0	26	82	49.8	36.0	33.8	15.7	13.7	M27
33430.W0030	152.0	30	82	49.8	36.0	42.3	21.5	15.5	M30
33430.W1008	87.5	8	49	30.0	21.5	2.1	0.9	0.8	M 8
33430.W1010	87.5	10	49	30.0	21.5	3.9	1.5	1.5	M10
33430.W1012	87.5	12	49	30.0	21.5	6.2	2.5	2.3	M12
33430.W1016	87.5	12	49	30.0	21.5	8.4	4.5	4.2	M15
33430.W1020	114.0	17	56	36.0	30.0	16.6	7.7	5.8	M20
33430.W1024	152.0	22	82	49.8	36.0	23.0	11.1	8.6	M24

QUICK LIFT PINS

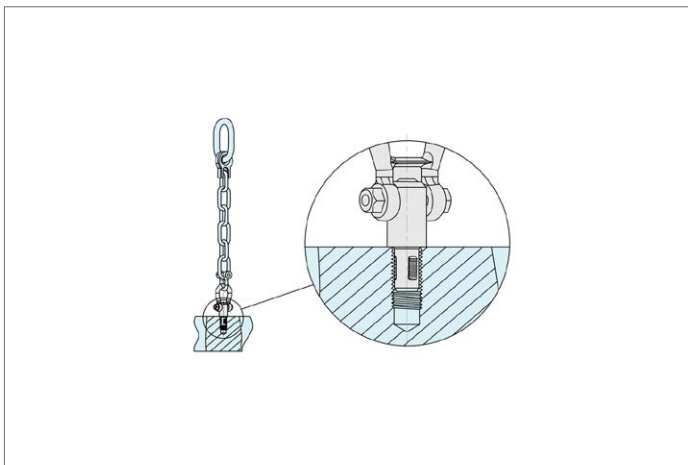



Quick Lift Pins - Threaded inch

Quick Lift Pins

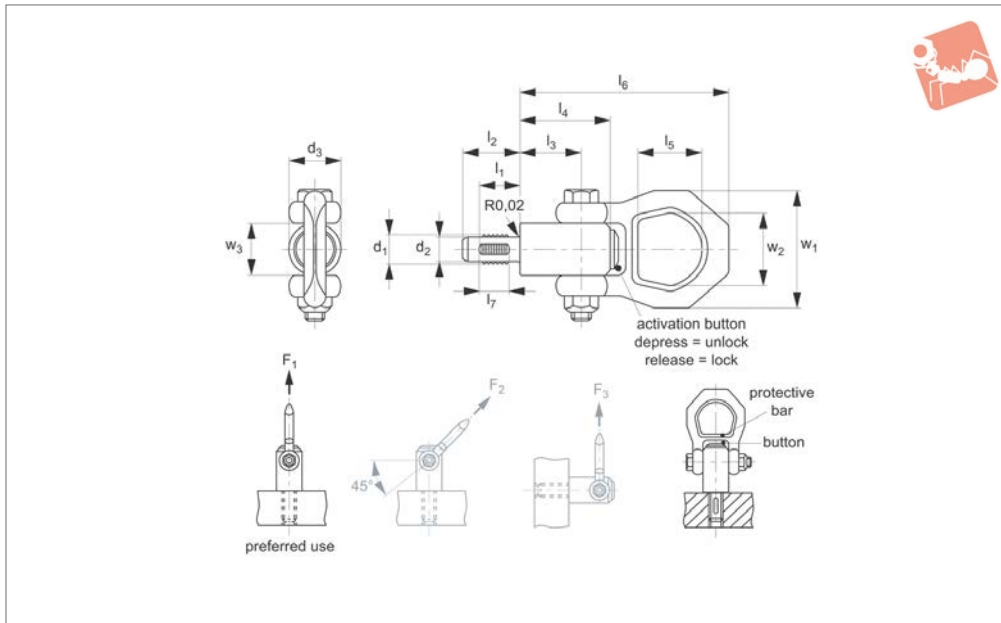

3B430

QUICK LIFT PINS

Material

Steel:

Pin: heat-treated steel, tempered, manganese phosphated.
Threaded element: stainless steel 1.4542, (AISI 630) precipitation hardened.
Shackle: steel, heat-treated, tempered, manganese phosphated.
Press button: aluminium, orange anodised.
Spring: stainless steel.

Stainless steel:

Pin: stainless steel 1.4542, (AISI 630) precipitation hardened.
Threaded element: stainless steel 1.4542, (AISI 630) precipitation hardened.
Shackle: stainless steel 1.45471.
Press button: aluminium, orange anodised.
Spring: stainless steel.

Technical Notes

To suit inch coarse threads, tolerance g6.

CE marked. Both types are corrosion protected. The stainless steel pin is resistant to corrosion and weathering, so suitable for external use.

The instruction manual and CE Declaration of Conformity are included.

F_1^* and F_3^* values are inscribed on the body for reference. F values are calculated on 5 x safety factor.

Depress button: to unlock.

Release button: to lock.

Max temp. 482°F 250°C.

Tips

The pin is ideally used for single point straight up lifts. The bottom face of the pin must be in full contact with the part to be lifted. The pin can also be used with forces F_2 and F_3 after ensuring that the shackle direction is aligned to the direction of the pull. The preferred part for these types of lifts is part 33425, which has a double

swivel function.

Before use: read instruction manual, and data sheets follow standard safe lifting procedures.

Important Notes

The threaded pin must be completely screwed into the thread and tightened to specified tightening torque and bear completely on the bearing surface. Quick and easy to use. The shackle pivots. The protective bar prevents unintentional unlocking by a hook or similar.

Use recommended mainly for direct upwards lift (F_1) as the shackle should be aligned to the direction of lift. Other pins (33425) have a swivel bearing to align shackle.

Rotation of loads must be prevented.

Dimensions in inches

Order No.	Type	l_1	d_1	d_2 inch -0,0028	d_3	l_2	l_3	l_4	Weight lb
3B430.W0012	Steel	0.67	1/2"-13	0.42	0.85	0.95	1.01	1.42	0.5
3B430.W0020	Steel	0.87	3/4"-10	0.64	1.18	1.18	1.44	2.05	1.1
3B430.W0024	Steel	1.06	1"-8	0.86	1.42	1.42	1.65	2.36	2.6
3B430.W1012	Stainless Steel	0.67	1/2"-13	0.42	0.85	0.95	1.01	1.42	0.5
3B430.W1020	Stainless Steel	0.87	3/4"-10	0.64	1.18	1.18	1.44	2.05	1.1
3B430.W1024	Stainless Steel	1.06	1"-8	0.86	1.42	1.42	1.65	2.36	2.7

Order No.	l_5	l_6	l_7	w_1	w_2	w_3	F_1 lbf	F_2 lbf	F_3 lbf	Locating thread
3B430.W0012	1.06	3.45	0.47	1.93	1.18	0.85	1528	764	607	1/2"-13
3B430.W0020	1.28	4.49	0.67	2.21	1.42	1.18	3619	1731	1281	3/4"-10
3B430.W0024	1.99	5.98	0.87	3.23	1.96	1.42	6766	3147	2225	1"-8

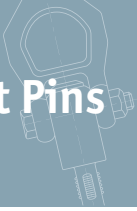

Order No.	l_5	l_6	l_7	w_1	w_2	w_3	F_1 lbf	F_2 lbf	F_3 lbf	Locating thread
3B430.W1012	1.06	3.45	0.47	1.93	1.18	0.85	1528	764	607	1/2"-13
3B430.W1020	1.28	4.49	0.67	2.21	1.42	1.18	3619	1731	1281	3/4"-10
3B430.W1024	1.99	5.98	0.87	3.23	1.96	1.42	6766	3147	2225	1"-8

QUICK LIFT PINS

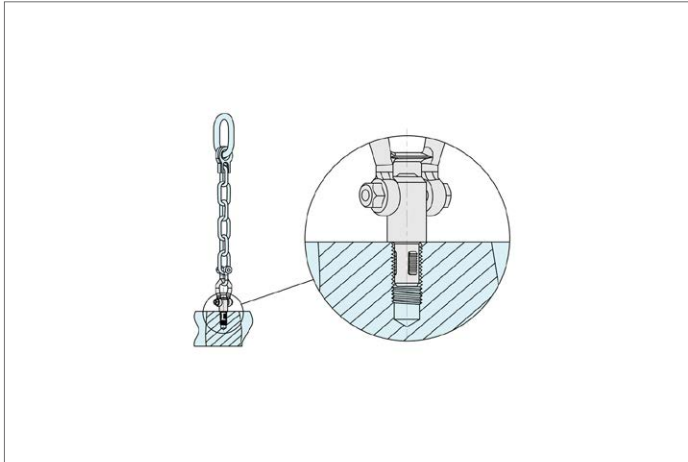



Quick Lift Pins - Threaded with centering - metric

Quick Lift Pins

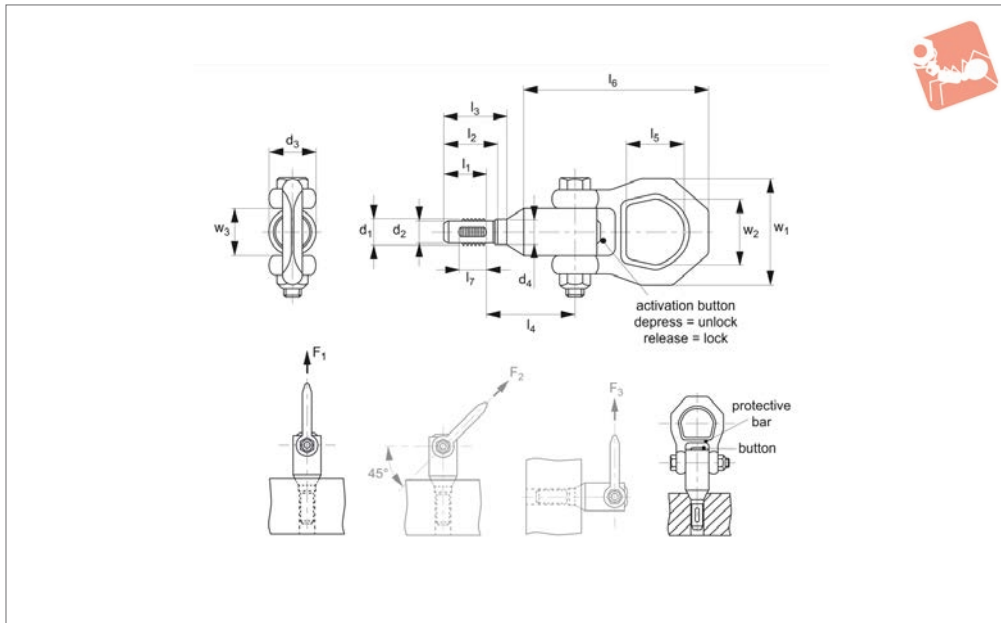

33435

QUICK LIFT PINS

Material

Steel:

Pin: heat-treated steel, tempered, manganese phosphated.

Threaded element: stainless steel 1.4542, (AISI 630) precipitation hardened.

Shackle: steel, heat-treated, tempered, manganese phosphated.

Press button: aluminium, orange anodised.

Spring: stainless steel.

Stainless steel:

Pin: stainless steel 1.4542, (AISI 630) precipitation hardened.

Threaded element: stainless steel 1.4542, (AISI 630) precipitation hardened.

Shackle: stainless steel 1.45471.

Press button: aluminium, orange anodised.

Spring: stainless steel.

Technical Notes

To suit metric coarse threads, tolerance g6.

CE marked. Both types are corrosion protected. The stainless steel pin is resistant to corrosion and weathering, so suitable for external use.

The instruction manual and CE Declaration of Conformity are included.

F_1^* and F_3^* values are inscribed on the body for reference. F values are calculated on 5 x safety factor.

Depress button: to unlock.

Release button: to lock.

Max temp. 250°C.

Tips

For holes with counterbore to DIN 332.

The pin is ideally used for single point straight up lifts. The bottom face of the pin must be in full contact with the part to be lifted. The pin can also be used with forces F_2 and F_3 after ensuring that the shackle direction is aligned to the direction of the pull. The preferred part for these types of

lifts is part 33425, which has a double swivel function.

Before use: read instruction manual, and data sheets follow standard safe lifting procedures.

Important Notes

The threaded pin must be completely screwed into the thread and tightened to specified tightening torque and bear completely on the bearing surface. Quick and easy to use. The shackle pivots. The protective bar prevents unintentional unlocking by a hook or similar.

Use recommended mainly for direct upwards lift (F_1) as the shackle should be aligned to the direction of lift. Other pins (33425) have a swivel bearing to align shackle.

Rotation of loads must be prevented.

Order No.	Type	l_1	d_1	d_2 -0.07	d_3	d_4	l_2	l_3	l_4	Weight g
33435.W2010	Steel	16.0	M10	8.4	21.5	10.2	20.0	22.9	36.4	234
33435.W2012	Steel	19.0	M12	10.1	21.5	12.7	24.0	28.1	39.1	249
33435.W2016	Steel	19.0	M16	13.8	21.5	16.7	25.0	30.5	42.3	271
33435.W2020	Steel	25.0	M20	17.8	30.0	20.7	31.8	39.1	53.7	554
33435.W2024	Steel	31.0	M24	20.7	36.0	24.7	38.9	47.3	61.4	1234
33435.W3010	Stainless Steel	16.0	M10	8.4	21.5	10.2	20.0	22.9	36.4	235
33435.W3012	Stainless Steel	19.0	M12	10.1	21.5	12.7	24.0	28.1	39.1	248
33435.W3016	Stainless Steel	19.0	M16	13.8	21.5	16.7	25.0	30.5	42.3	269
33435.W3020	Stainless Steel	25.0	M20	17.8	30.0	20.7	31.8	39.1	53.7	555
33435.W3024	Stainless Steel	31.0	M24	20.7	36.0	24.7	38.9	47.3	61.4	1264



Order No.	l_5	l_6	l_7	w_1	w_2	w_3	F_1 kN	F_2 kN	F_3 kN	Locating thread
33435.W2010	27.0	83.6	10	49	30.0	21.5	3.9	1.5	1.5	M10
33435.W2012	27.0	84.3	12	49	30.0	21.5	6.2	2.5	2.3	M12
33435.W2016	27.0	88.5	12	49	30.0	21.5	8.4	4.5	4.2	M16
33435.W2020	32.6	109.2	17	56	36.0	30.0	16.6	7.7	5.8	M20
33435.W2024	50.6	145.4	22	82	49.8	36.0	23.0	11.1	8.6	M24
33435.W3010	27.0	83.6	10	49	30.0	21.5	3.9	1.5	1.5	M10
33435.W3012	27.0	84.3	12	49	30.0	21.5	6.2	2.5	2.3	M12
33435.W3016	27.0	88.5	12	49	30.0	21.5	8.4	4.5	4.2	M16
33435.W3020	32.6	109.2	17	56	36.0	30.0	10.0	7.7	5.8	M20
33435.W3024	50.6	145.4	22	82	49.8	36.0	23.0	11.1	8.6	M24

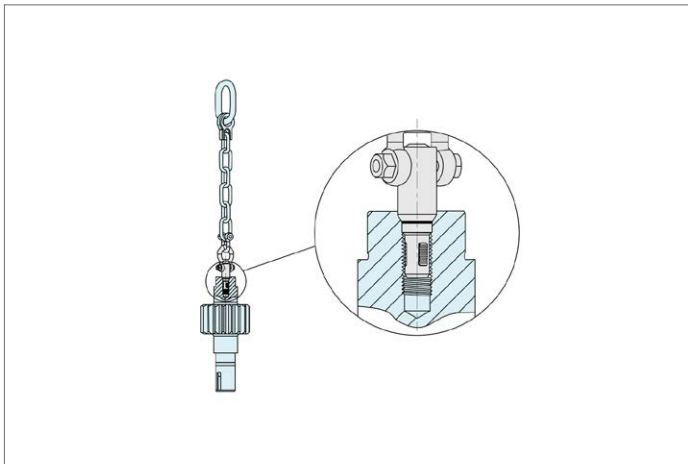



Lifting Pins-Self-Locking with t-handle - stainless steel

Quick Lift Pins

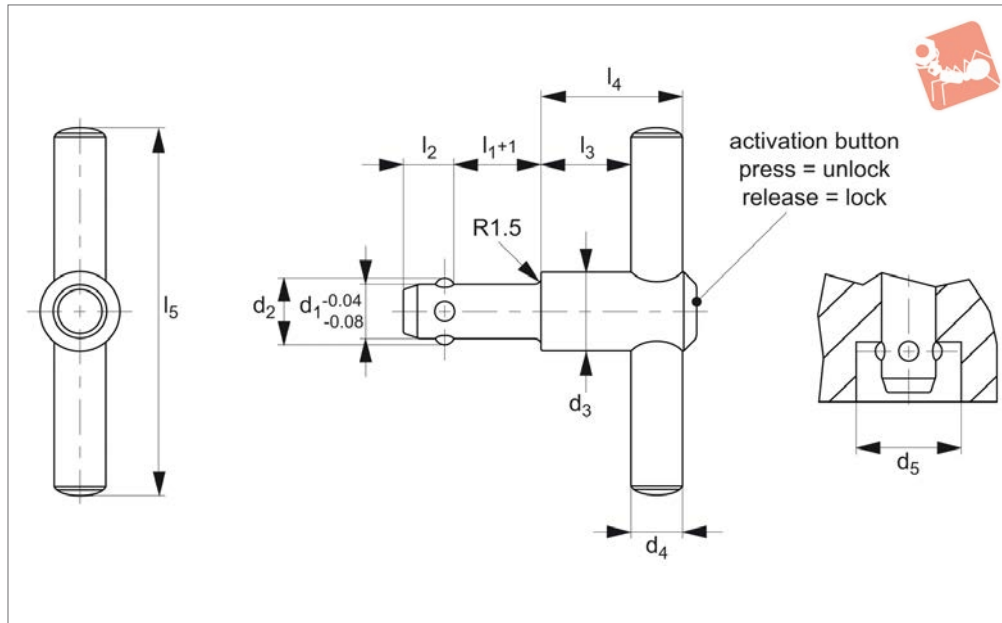

33424

QUICK LIFT PINS

Material

Pin: Stainless steel 1.4542, (AISI 630) precipitation hardened.
Handle: Aluminium, blue anodised
Spring: Stainless Steel

Releasing= Locking.

Easy installation with plain drilled hole to H11 tolerance
Temperature resistance up to 250° C

finished components, work holding systems, speakers and other containers.
Corrosion and weathering resistant, thus also suitable for outdoor application.

Technical Notes

Pressing= Unlocking.

Tips

The t-handled grip can be used to move or transport workpieces via hand, e.g. part

Order No.	d_1 -0.04 -0.08	l_1 +1	d_2	d_3	d_4	d_5 min.	l_2	l_3	l_4	l_5	Carrying force N	Location hole tol. H11	Weight g
33424.W0005	8.0	35	9.35	21.5	14	9.85	8.75	18.7	36.0	100	500	8.0	141
33424.W0010	8.3	35	9.65	21.5	14	10.05	8.75	18.7	36.0	100	500	8.3	142
33424.W0015	10.0	50	11.70	21.5	14	12.20	10.20	18.7	36.5	100	500	10.0	159
33424.W0020	12.0	50	14.20	21.5	14	14.70	11.00	18.7	36.5	100	500	12.0	177

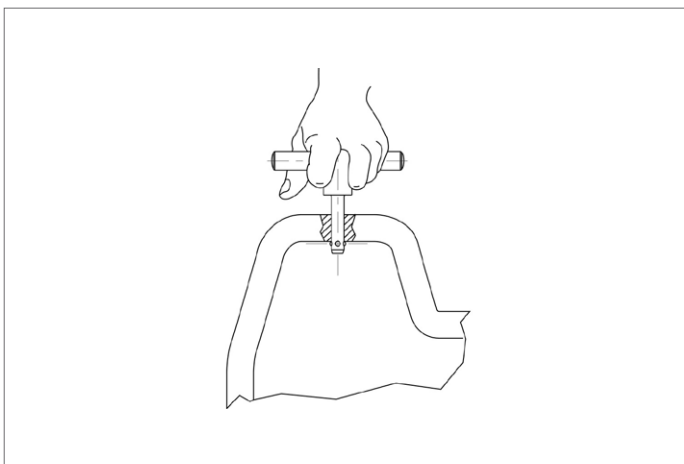



33440

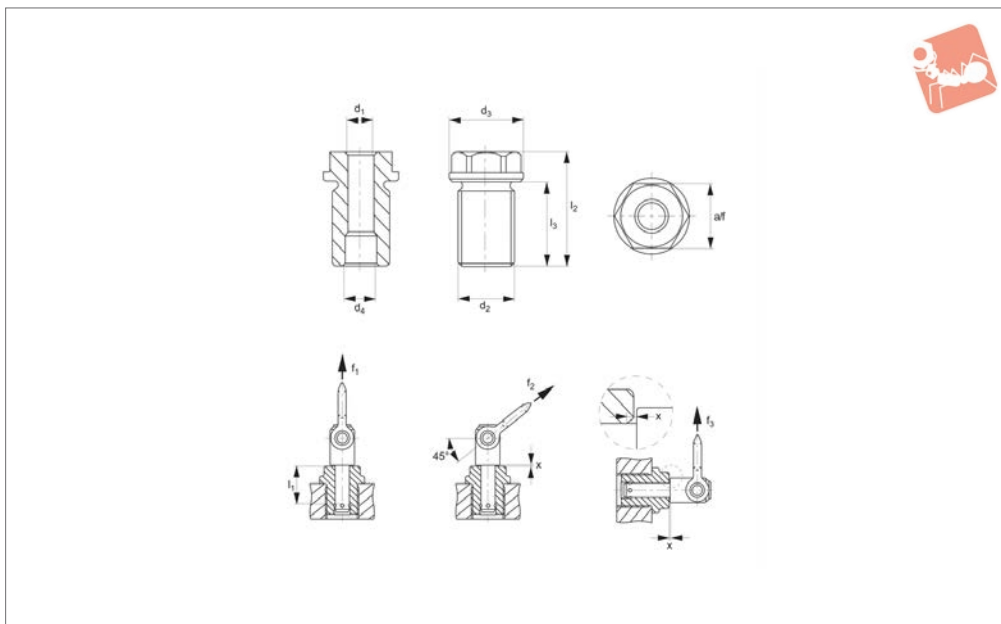

Material

Body: stainless steel 1.4542 (AISI 630), precipitation hardened.

Technical Notes

Locating bushes are used for quick and safe locating of lifting pins 33400 and 33420.

Provides easy and safe assembly, and can be incorporated into a variety of materials. Can be used in thin-walled parts and in blind holes.

Important Notes

Lifting forces f_1 to f_3 , have a 5 fold in-built

safety factor.

Due to the radius on the underside of the lifting face, please ensure $x_{min.}$ is $x_{max.}$ to avoid stress on pin when used as angle lift. See product table for details.

Order No.	For pin length	d ₁ tol. H11	d ₂	d ₃ -0.2	d ₄ +0.3	l ₂	l ₃	A/F	x max.	F ₁ kN	F ₂ kN	F ₃ kN	Starting torque Nm max.	For lifting pin 33400/33420	Weight g
33440.W0900	10	8	M16x1,5	24	9,8	27,5	20	19	1,5	1,5	1,2	0,5	90	.W0601/.W0701	32
33440.W0902	15	8	M16x1,5	24	9,8	27,5	20	19	1,5	1,5	1,2	0,5	90	.W0602/.W0702	33
33440.W0904	25	8	M16	24	9,8	37,5	25	19	1,5	1,5	1,2	0,5	75	.W0604/.W0704	46
33440.W0906	35	8	M16	24	9,8	47,5	35	19	1,5	1,5	1,2	0,5	75	.W0606/.W0706	55
33440.W0910	15	10	M20x1,5	28	12,2	35,5	24	24	1,0	2,7	2,4	2,1	145	.W0621/.W0721	70
33440.W0912	25	10	M20x1,5	28	12,2	35,5	24	24	1,0	2,7	2,4	2,1	145	.W0623/.W0723	73
33440.W0914	35	10	M20	28	12,2	46,0	29	24	1,0	2,7	2,4	2,1	130	.W0625/.W0725	93
33440.W0916	50	10	M20	28	12,2	65,0	49	24	1,0	2,7	2,4	2,1	130	.W0627/.W0727	117
33440.W0920	15	12	M24x1,5	32	14,7	35,5	24	27	1,0	3,5	3,2	2,8	220	.W0631/.W0731	94
33440.W0922	25	12	M24x1,5	32	14,7	36,5	24	27	1,0	3,5	3,2	2,8	220	.W0633/.W0733	102
33440.W0924	35	12	M24	32	14,7	48,5	36	27	1,0	3,5	3,2	2,8	200	.W0635/.W0735	119
33440.W0926	50	12	M24	32	14,7	72,5	60	27	1,0	3,5	3,2	2,8	200	.W0637/.W0737	164
33440.W0930	25	16	M30x2,0	39	19,2	44,0	29	30	1,0	4,8	4,5	4,1	440	.W0641/.W0741	163
33440.W0934	50	16	M30	39	19,2	66,0	44	30	1,0	4,8	4,5	4,1	400	.W0643/.W0743	236
33440.W0936	75	16	M30	39	19,2	96,0	74	30	1,0	4,8	4,5	4,1	400	.W0645/.W0745	323
33440.W0954	50	20	M36x2,0	43	26,0	70,0	55	36	1,5	10,0	8,5	6,5	440	.W0673/.W0773	366
33440.W0956	75	20	M36x2,0	43	26,0	95,0	80	36	1,5	10,0	8,5	6,5	440	.W0673/.W0775	503



Locating Bushes, Plain

for quick lift pins no.'s 33400 and 33420

Quick Lift Pins

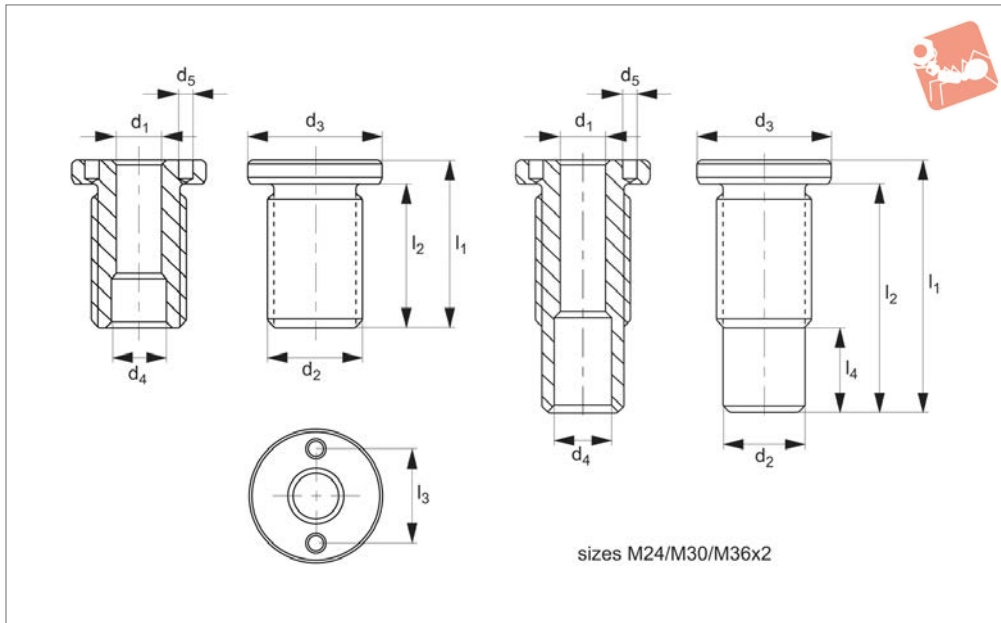

33442

QUICK LIFT PINS

Material

Stainless steel 1.4542, (AISI 630) precipitation hardened.

Technical Notes

Suitable for applications which require installation flush to the surface. These are used for quick and safe locating

of lifting pins.

Corrosion and abrasion resistant.

Reference 'l' indicates nominal length lifting pin grip length to suit the bush. See lifting pin ranges 33400 & 33420.

Important Notes

Alternative installation tools are available.

See part no. 94000.W0061 for 33442.

W1900 to W1906

or 94000.W0063 for 33442.W1910 to W1956

Order No.	For pin dia. d_1 nom.	For pin length nom.	d_1 tol. H11	d_2	d_3 -0.2	d_4 +0.3	Weight g	
33442.W1900	8	10	8	M16 x 1,5	24	9.8	33	
33442.W1902	8	15	8	M16 x 1,5	24	9.8	33	
33442.W1904	8	25	8	M16	24	9.8	33	
33442.W1906	8	35	8	M16	24	9.8	33	
33442.W1910	10	15	10	M20 x 1,5	28	12.2	70	
33442.W1912	10	25	10	M20 x 1,5	28	12.2	70	
33442.W1914	10	35	10	M20	28	12.2	70	
33442.W1916	10	50	10	M20	28	12.2	70	
33442.W1920	12	15	12	M24 x 1,5	32	14.7	94	
33442.W1922	12	25	12	M24 x 1,5	32	14.7	94	
33442.W1924	12	35	12	M24	32	14.7	94	
33442.W1926	12	50	12	M24	32	14.7	94	
33442.W1930	16	25	16	M30 x 2	39	19.2	163	
33442.W1934	16	50	16	M30	39	19.2	163	
33442.W1936	16	75	16	M30	39	19.2	163	
33442.W1954	20	50	20	M36 x 2	43	26.0	340	
33442.W1956	20	75	20	M36 x 2	43	26.0	340	
33442.W9095	Inst. adapter for socket wrench for 33442.W1900 to .W1906							-
33442.W9096	Inst. adapter for socket wrench for 33442.W1910 to .W1916							-
33442.W9097	Inst. adapter for socket wrench for 33442.W1920 to .W1926							-
33442.W9098	Inst. adapter for socket wrench for 33442.W1930 to .W1956							-

Order No.	d_5 +0.1	l_1	l_2	l_3	l_4	x mm	F_1 kN	F_2 kN	F_3 kN	Tightening torque max.	For lifting pin 33400	For lifting pin 33420
33442.W1900	3.1	25	20	16	-	1.5	1.5	1.2	0.5	75	33400.W0601	33420.W0701
33442.W1902	3.1	25	20	16	-	1.5	1.5	1.2	0.5	75	33400.W0602	33420.W0702
33442.W1904	3.1	35	30	16	-	1.5	1.5	1.2	0.5	75	33400.W0604	33420.W0704
33442.W1906	3.1	45	40	16	-	1.5	1.5	1.2	0.5	75	33400.W0606	33420.W0706
33442.W1910	5.1	30	24	20	-	1.5	2.7	2.4	2.1	100	33400.W0621	33420.W0721
33442.W1912	5.1	35	29	20	-	1.5	2.7	2.4	2.1	100	33400.W0623	33420.W0723

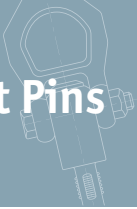

Locating Bushes, Plain

for quick lift pins no.'s 33400 and 33420



QUICK LIFT PINS

Order No.	d ₅ +0.1	l ₁	l ₂	l ₃	l ₄	x mm	F ₁ kN	F ₂ kN	F ₃ kN	Tightening torque max.	For lifting pin 33400	For lifting pin 33420
33442.W1914	5.1	45	39	20	-	1.5	2.7	2.4	2.1	100	33400.W0625	33420.W0725
33442.W1916	5.1	60	54	20	-	1.5	2.7	2.4	2.1	100	33400.W0627	33420.W0727
33442.W1920	5.1	32	26	22	-	1.5	3.5	3.2	2.8	150	33400.W0631	33420.W0731
33442.W1922	5.1	40	34	22	-	1.5	3.5	3.2	2.8	150	33400.W0633	33420.W0733
33442.W1924	5.1	50	44	22	3.8	1.5	3.5	3.2	2.8	150	33400.W0635	33420.W0735
33442.W1926	5.1	65	59	22	18.8	1.5	3.5	3.2	2.8	150	33400.W0637	33420.W0737
33442.W1930	5.1	45	39	30	-	1.5	4.8	4.5	4.1	200	33400.W0641	33420.W0741
33442.W1934	5.1	65	59	30	6.0	1.5	4.8	4.5	4.1	200	33400.W0643	33420.W0743
33442.W1936	5.1	90	84	30	31.0	1.5	4.8	4.5	4.1	200	33400.W0645	33420.W0745
33442.W1954	5.1	70	63	30	3.5	1.5	10.0	8.5	6.5	200	33400.W0673	33420.W0773
33442.W1956	5.1	95	88	30	28.5	1.5	10.0	8.5	6.5	200	33400.W0675	33420.W0775
33442.W9095	-	-	-	-	-	-	-	-	-	-	-	-
33442.W9096	-	-	-	-	-	-	-	-	-	-	-	-
33442.W9097	-	-	-	-	-	-	-	-	-	-	-	-
33442.W9098	-	-	-	-	-	-	-	-	-	-	-	-



Locating Bushes with seal - for Quick stainless steel hardened

Quick Lift Pins

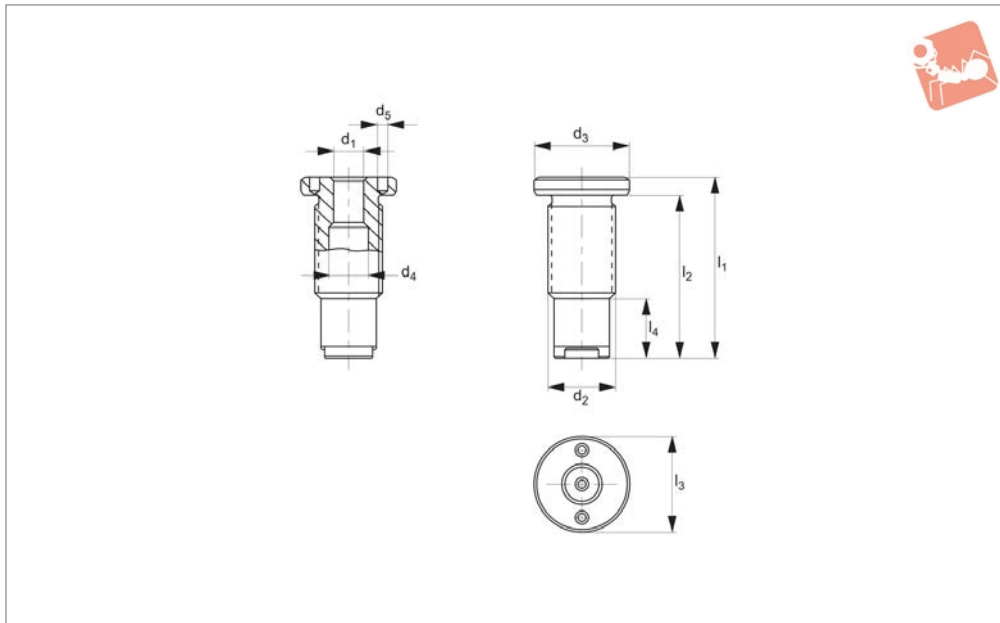

33444

QUICK LIFT PINS

Material

Body: stainless steel 1.4542 (AISI 630), precipitation hardened.
O-Ring: NBR rubber.
Spring: stainless steel.

Technical Notes

Ideal for outdoor use as seal prevents

ingress of liquid or dirt. Locating bushes are used for quick and safe locating of lifting pins 33400 and 33420. Provides easy and safe assembly, and can be incorporated into a variety of materials. Can be used in thin-walled parts and in blind holes.

Tips

Installation using:
33442 Instal tool for bushing

Important Notes

Lifting forces f_{1*} , f_{2*} , f_{3*} have a 5 fold in-built safety factor.

Order No.	d_1	d_2	d_3	d_4	d_5	l_1	l_2	l_3	l_4	F_1 kN	F_2 kN	F_3 kN	Tightening torque Nm max.	For lifting pin 33400/33420	Weight g
33444.W1960	8	M16x1,5	24	9,9	3,1	37,5	32,5	16	12,5	1,5	1,2	0,5	75	.W0601/.W0701	40
33444.W1961	10	M20x1,5	28	12,3	5,1	51,0	45,0	20	21,0	2,7	2,4	2,1	100	.W0621/.W0721	82
33444.W1962	12	M24x1,5	32	14,4	5,1	53,0	47,0	22	21,0	3,5	0,2	2,8	150	.W0631/.W0731	125
33444.W1963	16	M30x2,0	39	19,3	5,1	78,0	72,0	30	33,0	4,8	4,5	4,1	200	.W0641/.W0741	252



63050

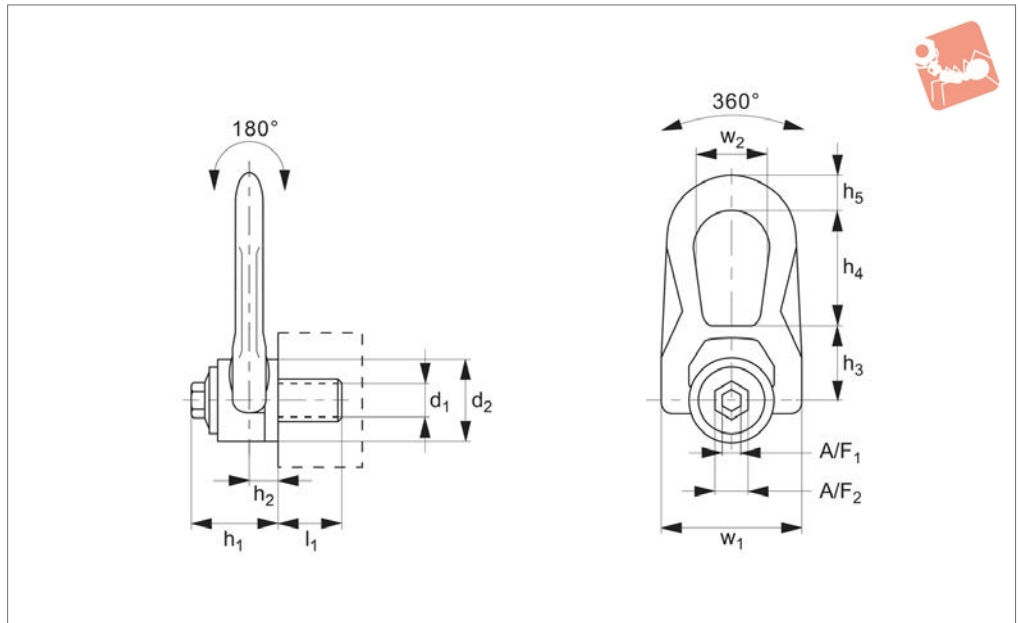

Material

High tensile steel, strength class >8.
Supplied with CE certificate.

Technical Notes

Double articulation.
Very low overhang for improved safety.
Large support surface.
Longer or shorter thread lengths can be supplied but please consult our technical department for this information if required.
For use in temperatures from -20°C to +200°C. Can be used in lower or higher

temperatures but this affects the load rating - please ask for more information. Please refer to our technical information pages when specifying and/or using.

Tips

Double articulation allows perfect alignment with the sling if the part rotates during the lift.
With „automatic“ position recovery system for best orientation to sling direction.
Tighten by hex. key or spanner.

Important Notes

The thread diameter and depth must be appropriate to the material into which it will be installed:

Steel (min. ST37) - 1 x thread dia.

Cast iron - 1.25 x thread dia.

Aluminium - 2 x thread dia.

Other light metals - 2.5 x thread dia.

Tolerance of female thread to be 6H (metric) or UNC-2B (inch).

Please refer to the safety documentation before using this part.

Supplied with certificate and operating

Order No.	Load tons (t) max.	d ₁ tol. 6g (tol. 2A)	l ₁	h ₁	h ₂	h ₃	h ₄	h ₅	w ₁	d ₂	w ₂	A/F ₁	A/F ₂	Safety factor	Torque to Nm (ft-lb)	Weight kg
63050.W0005	0,1	M 5x 0,80	15	33	9,5	30	38	14	53	30	27	8	16	4	3	0,3
63050.W0006	0,2	M 6x 1,00	15	33	9,5	30	38	14	53	30	27	8	16	4	4	0,3
63050.W0008	0,5	M 8x 1,25	15	33	9,5	30	38	14	53	30	27	8	16	4	6	0,3
63050.W0010	0,9	M10x1,50	18	33	9,5	30	38	14	53	30	27	8	16	4	10	0,3
63050.W0012	1,3	M12x1,75	21	33	9,5	30	38	14	53	30	27	8	16	4	15	0,3
63050.W0014	1,8	M14x2,00	23	45	13	40	53	17	76	45	38	8	20	4	30	0,9
63050.W0016	2,3	M16x2,00	27	45	13	40	53	17	76	45	38	8	20	4	50	0,9
63050.W0018	2,3	M18x2,50	27	45	13	40	53	17	76	45	38	8	20	4	70	0,9
63050.W0020	2,5	M20x2,50	30	45	13	40	53	17	76	45	38	8	20	4	100	0,9
63050.W0022	4,5	M22x2,50	33	62	19	55	83	25	115	60	55	14	24	4	120	2,6
63050.W0024	5,5	M24x3,00	36	62	19	55	83	25	115	60	55	14	24	4	160	2,6
63050.W0027	6,0	M27x3,00	40	62	19	55	83	25	115	60	55	14	24	4	200	2,7
63050.W0030	6,3	M30x3,50	45	62	19	55	83	25	115	60	55	14	24	4	250	2,7
63050.W0031	(1,200)	(UNC 5/16"-18)	15	33	9,5	30	38	14	53	30	27	8	16	4	(5)	0,3
63050.W0038	(1,600)	(UNC 3/8"-16)	17	33	9,5	30	38	14	53	30	27	8	16	4	(8)	0,3
63050.W0050	(2,800)	(UNC 1/2"-13)	21	33	9,5	30	38	14	53	30	27	8	16	4	(12)	0,3
63050.W0058	(4,900)	(UNC 5/8"-11)	27	45	13	40	53	17	76	45	38	8	20	4	(40)	0,9
63050.W0075	(5,250)	(UNC 3/4"-10)	30	45	13	40	53	17	76	45	38	8	20	4	(80)	0,9
63050.W0100	(12,500)	(UNC 1"-8)	36	62	19	55	83	25	115	60	55	14	24	4	(125)	2,6



Swivel Lifting Rings

max. load rating - per lifting configuration

63050

Materials Handling

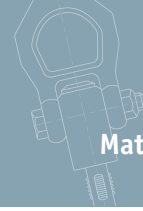

LIFTING POINTS & SHACKLES



63050 Male

Lifting configuration								
No. of rings	1	2	1	2	2	2	4	4
Lifting angle	0°	0°	90°	90°	45°	60°	45°	60°
Thread	Maximum load rating for given lifting configuration							
M4	tons 0,050	0,100	0,050	0,100	0,070	0,050	0,100	0,050
M5	tons 0,075	0,150	0,075	0,150	0,100	0,075	0,150	0,075
M6	tons 0,100	0,200	0,100	0,200	0,140	0,100	0,200	0,100
M8	tons 0,30	0,60	0,30	0,60	0,40	0,30	0,60	0,30
M10	tons 0,60	1,20	0,60	1,20	0,80	0,60	1,30	0,60
M12	tons 1,00	2,00	1,00	2,00	1,40	1,00	2,10	1,00
M14	tons 1,30	2,60	1,30	2,60	1,80	1,30	2,70	1,30
M16	tons 1,60	3,20	1,60	3,20	2,20	1,60	3,40	1,60
M18	tons 2,00	4,00	2,00	4,00	2,80	2,00	4,20	2,00
M20	tons 2,50	5,00	2,50	5,00	3,50	2,50	5,30	2,50
M22	tons 3,00	6,00	3,00	6,00	4,20	3,00	6,30	3,00
M24	tons 4,00	8,00	4,00	8,00	5,60	4,00	8,40	4,00
M27	tons 5,00	10,00	5,00	10,00	7,00	5,00	10,50	5,00
M30	tons 6,30	12,6	6,30	12,600	8,8	6,30	13,200	6,30
(UNC 5/16"-18)	lbs 650	1,300	650	1,300	910	650	1,365	650
(UNC 3/8"-16)	lbs 1,200	2,400	1,200	2,400	1,680	1,200	2,520	1,200
(UNC 1/2"-13)	lbs 2,200	4,400	2,200	4,400	3,080	2,200	4,620	2,200
(UNC 5/8"-11)	lbs 3,800	7,600	3,800	7,600	5,320	3,800	7,980	3,800
(UNC 3/4"-10)	lbs 5,500	11,000	5,500	11,000	7,700	5,500	11,550	5,500
(UNC 7/8"-9)	lbs 6,600	13,200	6,600	13,200	9,240	6,600	13,860	6,600

Important Note: Table shows the maximum load rating for a given lifting configuration (NOT maximum load rating per individual lifting ring).

ov-W63050-AP4005-T-swivel-lifting-ring-rmh- Updated -28-10-2022



63080.1

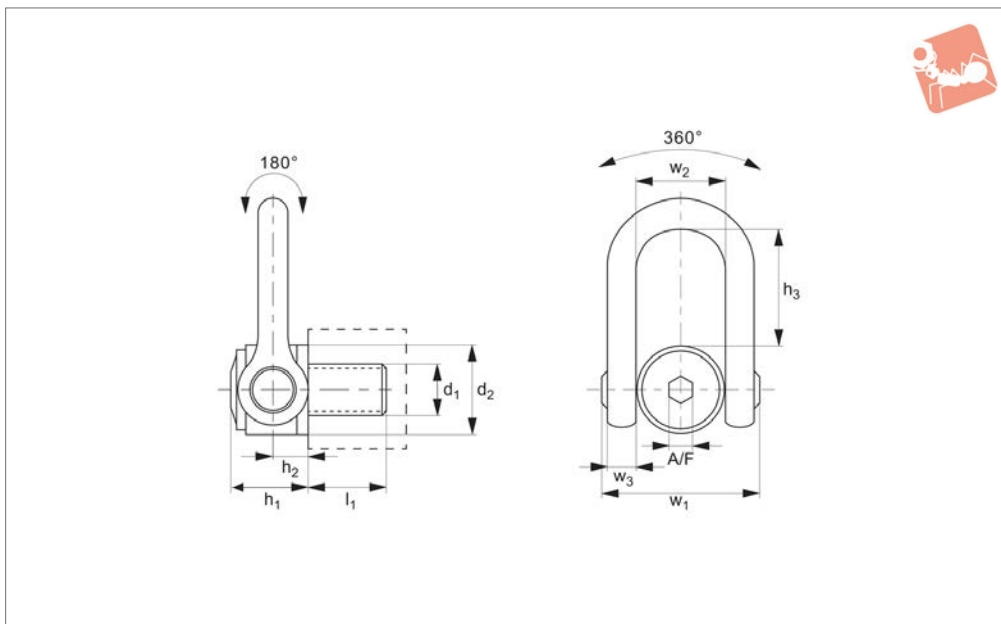

Material

High tensile steel, strength class >8.
Supplied with CE certificate.

Technical Notes

Double articulation.
Very low overhang for improved safety.
Large support surface.
For use in temperatures from -20°C to +200°C. Can be used in lower or higher temperatures, but this affects the load rating - please ask for more information.

Please refer to our technical information pages when specifying and/or using.

Tips

Double articulation allows perfect alignment with the sling if the part rotates during the lift.
With „automatic“ position recovery system for best orientation to sling direction.
Tighten by hex. key or spanner.

Important Notes

The thread diameter and depth must be

appropriate to the material into which it will be installed:

Steel (min. ST37) - 1 x thread dia.

Cast iron - 1.25 x thread dia.

Aluminium - 2 x thread dia.

Other light metals - 2.5 x thread dia.

Tolerance of female thread to be 6H (metric) or UNC-2B (inch).

Please refer to the safety documentation before using this part.

Supplied with certificate and operating instructions.

Order No.	Load tons (t) max.	d ₁ tol. 6g (tol. 2A)	l ₁	h ₁	h ₂	h ₃	w ₁	d ₂	w ₂	w ₃	A/F	Safety factor	Torque to Nm (ft·lb)	Weight kg
63080.W0024	5.5	M24x3,0	36	61	31	98	149	70	73	33	19	4	160	5.4
63080.W0030	8.5	M30x3,5	45	61	31	98	149	70	73	33	19	4	250	5.5
63080.W0033	10.5	M33x3,5	50	61	31	98	149	70	73	33	19	4	250	5.5
63080.W0036	12.0	M36x4,0	54	61	31	98	149	70	73	33	19	4	320	5.5
63080.W0037	12.0	M36x3,0*	54	61	31	98	149	70	73	33	19	4	320	5.5
63080.W0039	14.0	M39x4,0	58	61	31	98	149	70	73	33	19	4	320	5.7
63080.W0042	15.0	M42x4,5	63	61	31	98	149	70	73	33	19	4	400	5.8
63080.W0043	15.0	M42x3,0*	63	61	31	98	149	70	73	33	19	4	400	5.8
63080.W0045	16.0	M45x4,5	63	61	31	98	149	70	73	33	19	4	400	5.9
63080.W0048	20.0	M48x5,0	68	79	38	123	182	90	91	45	19	4	600	11.0
63080.W0049	20.0	M48x3,0*	68	79	38	123	182	90	91	45	19	4	600	11.0
63080.W0050	20.0	M48x4,0*	68	79	38	123	182	90	91	45	19	4	600	11.0
63080.W0052	21.0	M52x5,0	68	79	38	123	182	90	91	45	19	4	600	11.2
63080.W0056	25.0	M56x5,5	78	79	38	123	182	90	91	45	19	4	600	11.3
63080.W0057	25.0	M56x4,0*	78	79	38	123	182	90	91	45	19	4	600	11.4
63080.W0064	32.1	M64x6,0	90	79	38	123	182	95	91	45	19	4	600	12.2
63080.W0065	32.1	M64x4,0*	90	79	38	123	182	95	91	45	19	4	600	12.2
63080.W0072	25.0	M72x6,0*	90	79	38	123	182	95	91	45	19	4	600	14.0
63080.W0073	25.0	M72x4,0*	90	79	38	123	182	95	91	45	19	4	600	14.0
63080.W0080	32.1	M80x6,0*	90	79	38	123	182	100	91	45	19	4	600	15.0
63080.W0090	32.1	M90x6,0*	90	79	38	123	182	100	91	45	19	4	600	15.5
63080.W0100	32.1	M100x6,0*	90	79	38	123	182	110	91	45	19	4	600	16.5
63080.W0325	(19.000)	(UNC 1 1/4"-7)	45	61	31	98	149	70	73	33	19	4	(200)	5.4



Double Swivel Shackles Male

Lifting Points & Shackles



Order No.	Load tons (t) max.	d ₁ (tol. 2A)	l ₁	h ₁	h ₂	h ₃	w ₁	d ₂	w ₂	w ₃	A/F	Safety factor	Torque to Nm (ft·lb)	Weight kg
63080.W0350	(27.000)	(UNC 1 1/2"-6)	54	61	31	98	149	70	73	33	19	4	(240)	5.4
63080.W0400	(50.000)	(UNC 2"-4 1/2)	76	79	38	123	182	90	91	45	19	4	(450)	11.1

LIFTING POINTS & SHACKLES



63080.2

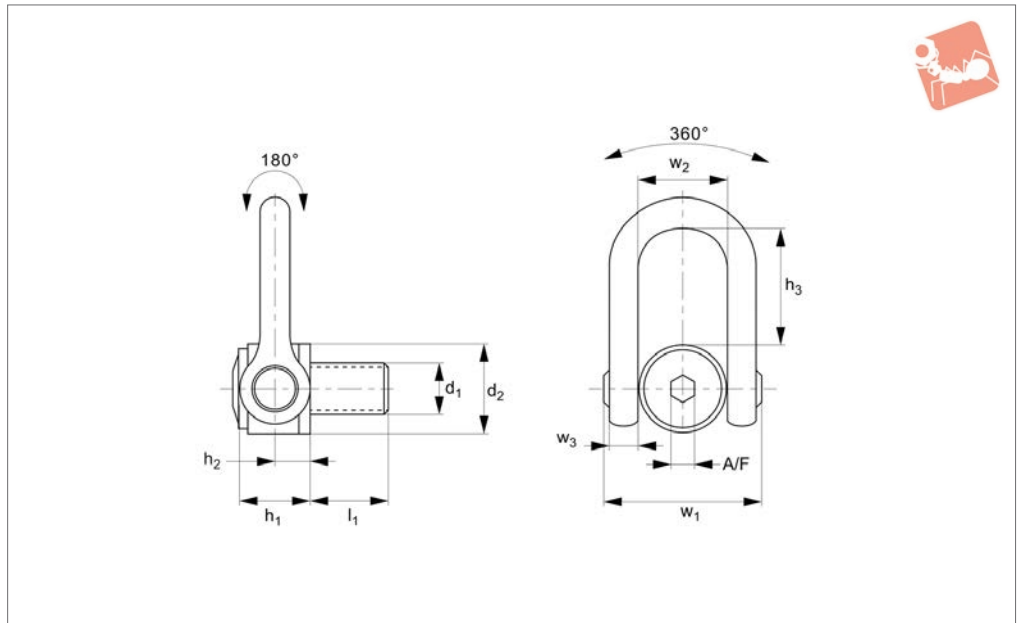

Material

High tensile steel, strength class >8.
Supplied with CE certificate.

Technical Notes

For use in temperatures from -20°C to +200°C. Can be used in lower or higher temperatures, but this affects the load rating - please ask for more information.
Please refer to our technical information pages when specifying and/or using.

Tips

Double articulation allows perfect alignment with the sling if the part rotates during the lift.
With „automatic“ position recovery system for best orientation to sling direction.
Tighten by hex. key or spanner.

Important Notes

The thread diameter and depth must be appropriate to the material into which it will be installed:

Steel (min. ST37) - 1 x thread dia.

Cast iron - 1.25 x thread dia.

Aluminium - 2 x thread dia.

Other light metals - 2.5 x thread dia.

Tolerance of female thread to be 6H (metric) or UNC-2B (inch).

Please refer to the safety documentation before using this part.

Supplied with certificate and operating instructions.



Swivel Lifting Rings

max. load rating - per lifting configuration

63080

Materials Handling

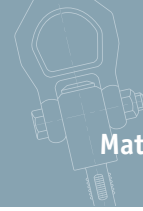

LIFTING POINTS & SHACKLES



63080 Male

63084 Female

Lifting configuration	1		2		2		4	
	0°	0°	90°	90°	45°	60°	45°	60°
No. of rings	1	2	1	2	2	2	4	4
Lifting angle	0°	0°	90°	90°	45°	60°	45°	60°
Thread	Maximum load rating for given lifting configuration							
M24 tons	4,50	9,00	4,50	9,00	6,30	4,50	9,50	4,50
M27 tons	5,00	10,00	5,00	10,00	7,00	5,00	10,50	5,00
M30 tons	7,30	14,60	7,30	14,60	10,20	7,30	15,30	7,30
M33 tons	8,00	16,00	8,00	16,00	11,20	8,00	16,80	8,00
M36 tons	10,00	20,00	10,00	20,00	14,00	10,00	21,00	10,00
M36* tons	10,00	20,00	10,00	20,00	14,00	10,00	21,00	10,00
M39 tons	10,00	20,00	10,00	20,00	14,00	10,00	21,00	10,00
M42 tons	12,50	25,00	12,50	25,00	17,50	12,50	26,30	12,50
M42* tons	12,50	25,00	12,50	25,00	17,50	12,50	26,30	12,50
M45 tons	15,00	30,00	15,00	30,00	21,00	15,00	31,50	15,00
M48 tons	20,00	40,00	20,00	40,00	28,00	20,00	42,00	20,00
M48* tons	20,00	40,00	20,00	40,00	28,00	20,00	42,00	20,00
M50 tons	20,00	40,00	20,00	40,00	28,00	20,00	42,00	20,00
M52 tons	20,00	40,00	20,00	40,00	28,00	20,00	42,00	20,00
M56 tons	25,00	50,00	25,00	50,00	35,00	25,00	52,50	25,00
M56* tons	25,00	50,00	25,00	50,00	35,00	25,00	52,50	25,00
M64 tons	32,10	64,20	32,10	64,20	44,90	32,10	67,40	32,10
M65 tons	32,10	64,20	32,10	64,20	44,90	32,10	67,40	32,10
M72 tons	25,00	50,00	25,00	50,00	35,00	25,00	52,50	25,00
M72* tons	25,00	50,00	25,00	50,00	35,00	25,00	52,50	25,00
M80 tons	32,10	64,20	32,10	64,20	44,90	32,10	67,40	32,10
M90 tons	32,10	64,20	32,10	64,20	44,90	32,10	67,40	32,10
M100 tons	32,10	64,20	32,10	64,20	44,90	32,10	67,40	32,10
(UNC 1"-8) lbs	10,000	20,000	10,000	20,000	14,000	10,000	21,000	10,000
(UNC 1 1/4"-7) lbs	14,000	28,000	14,000	28,000	19,600	14,000	29,400	14,000
(UNC 1 3/8"-6*) lbs	20,000	40,000	20,000	40,000	28,000	20,000	42,000	20,000
(UNC 1 1/2"-6) lbs	20,000	40,000	20,000	40,000	28,000	20,000	42,000	20,000
(UNC 2"-4 1/2) lbs	50,000	100,000	50,000	100,000	70,000	50,000	105,000	50,000

*Fine Thread

Important Note: Table shows the maximum load rating for a given lifting configuration (NOT maximum load rating per individual lifting ring).



63120

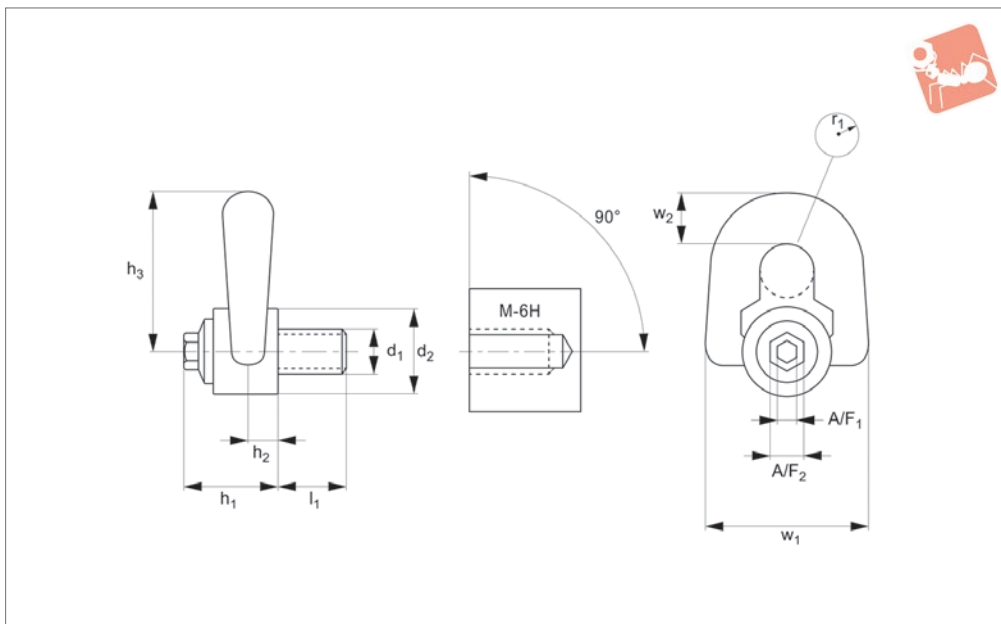

Material

High tensile steel, strength class >8.
Supplied with CE certificate.

Technical Notes

Double articulation.
Low overhang for improved safety.
For use in temperatures from -20°C to +200°C. Can be used in lower or higher temperatures, but this affects the load rating - please ask for more information.
Please refer to our technical information

pages when specifying and/or using.

Tips

Double articulation allows perfect alignment with the sling if the part rotates during the lift.
With „automatic“ position recovery system for best orientation to sling direction.
Tighten by hex. key or spanner.

Important Notes

The thread diameter and depth must be appropriate to the material into which it

will be installed:

Steel (min. ST37) - 1 x thread dia.
Cast iron - 1.25 x thread dia.
Aluminium - 2 x thread dia.
Other light metals - 2.5 x thread dia.
Tolerance of female thread to be 6H (metric) or UNC-2B (inch).
Please refer to the safety documentation before using this part.
Supplied with certificate and operating instructions.

Order No.	Load tons (t) max.	d ₁ tol. 6g (tol. 2A)	l	h ₁	h ₂	h ₃	w ₁	d ₂	R	w ₂	A/F ₁	A/F ₂	Safety factor	Torque to Nm (ft·lb)	Weight kg
63120.W0008	0.40	M8x 1,25	15	33	9.5	56	58	30	9.5	19	8	16	5	6	0.3
63120.W0010	0.70	M10x1,50	18	33	9.5	56	58	30	9.5	19	8	16	5	10	0.3
63120.W0012	1.05	M12x1,75	21	33	9.5	56	58	30	9.5	19	8	16	5	15	0.3
63120.W0014	1.40	M14x2,00	23	45	13.0	81	79	45	12.5	27	8	20	5	30	0.9
63120.W0016	2.00	M16x2,00	27	45	13.0	81	79	45	12.5	27	8	20	5	50	0.9
63120.W0018	2.30	M18x2,50	27	45	13.0	81	79	45	12.5	27	8	20	5	70	1.0
63120.W0020	2.50	M20x2,50	30	45	13.0	81	79	45	12.5	27	8	20	5	100	1.0
63120.W0231	(1.000)	(UNC 5/16"-18)	15	33	9.5	56	58	30	9.5	19	8	16	5	(7)	0.3
63120.W0250	(2.400)	(UNC 1/2"-13)	21	33	9.5	56	58	30	9.5	19	8	16	5	(12)	0.3
63120.W0275	(5.250)	(UNC 3/4"-10)	30	45	13.0	81	79	45	12.5	27	8	16	5	(80)	1.0



General product information

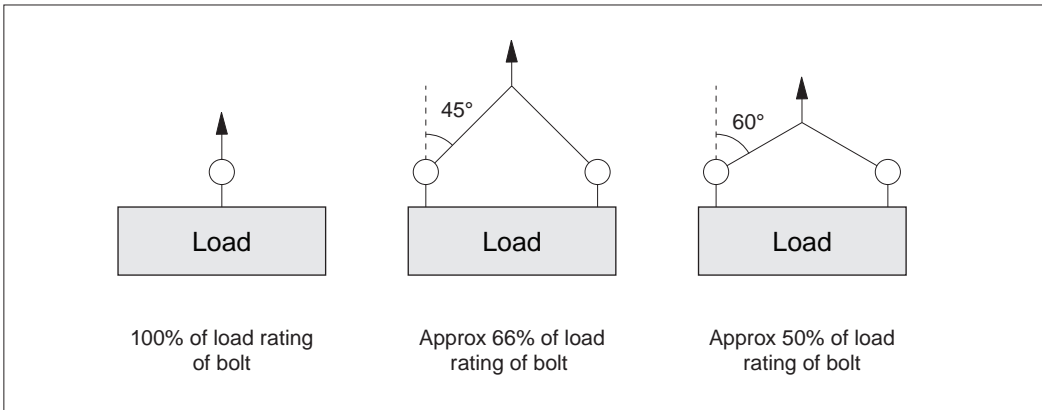

Lifting angles

For full information on lifting arrangements see technical pages

Installation information

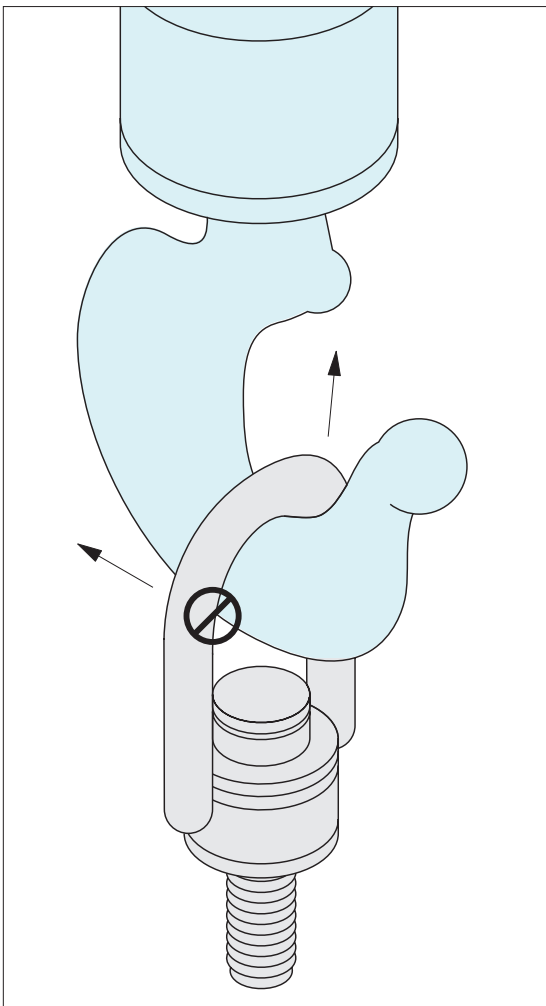

Never use an oversized hook or other lifting device which will pry or tend to open the "U" shaped bar on centre pull hoists rings.

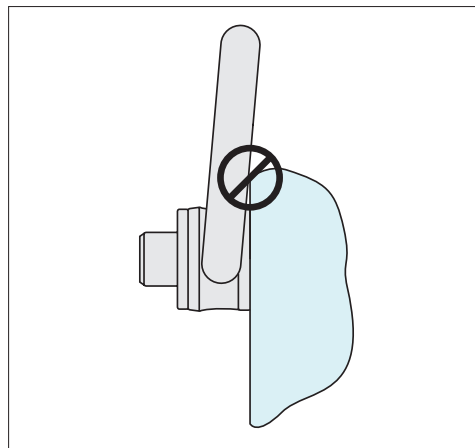

After installation, check the hoist ring to be sure it swivels and pivots freely in all directions. The side of the ring must not contact anything.

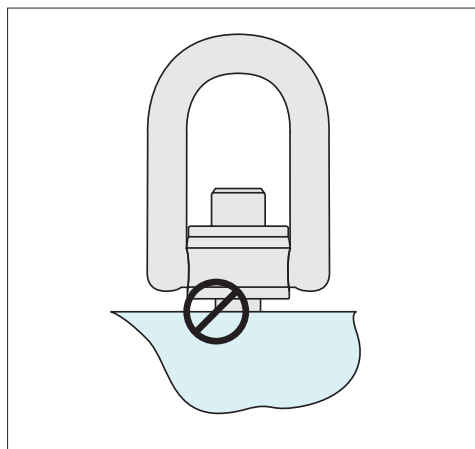

Always ensure full thread engagement when installing hoist rings.

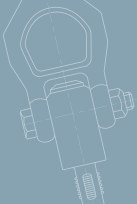

Instructional Overview

Operating instructions

Note: The full thread must be engaged. Longer thread lengths can be supplied on request or a bolt and washer/nut combination can be used.

- Ensure all lifting bolts are CE marked.
- Ensure they are handled by qualified personnel.
- Refer to the operating instructions particularly with regards to product selection, any possibility of the load swivelling, the effect of lifting angles on the load capacity (see relevant tables), etc.
- Never allow any personnel underneath a suspended load.
- Always heed the load rating of the lifting bolt.
- Always perform a visual inspection of the lifting rings prior to use. Checking for any damage to thread and/or swivelling system. Check for wear or corrosion, signs of stress or bending.
- Ensure a yearly full service inspection is performed.
- Always ensure the full bottom face of the lifting bolts is in contact with a smooth, square surface.
- Ensure bolt is tightened to the correct torque.
- Ensure full and unrestricted movement of the lifting ring in all directions.
- Before each lift ensure the correct orientation of the shackle in the lift direction.
- Avoid using our standard steel lifting rings in corrosive environments eg. sandy, chemical, acid, moisture etc. In this case consider using our stainless steel lifting rings.
- Note the thread length requirements:
 - 1 x thread diameter for steel (ST37 min.).
 - 1.25 x thread diameter for cast iron.
 - 2 x thread diameter for aluminium.
 - 2.5 x thread diameter for other light metals.
 - If fixing into low resistance material it is better to allow for a bigger diameter thread to compensate for the lower material resistance.

Temperature extremes

-40°C to -20°C	Load rating reduces by 20%.
+200°C to +300°C	Load rating reduces by 10%.
+300°C to +400°C	Load rating reduces by 25%.

Rugged environments



Certificate of Conformity

For harsh environments we recommend the use of our stainless steel lifting rings.



63200 - Threads M8 – M30
Loads 0,3 tons – 3 tons.

63210 - Threads M30 – M45
Loads 3,5 tons – 6 tons.



Benefits of Swivel Lifting Rings Over Lifting Rings



Materials Handling

LIFTING POINTS & SHACKLES

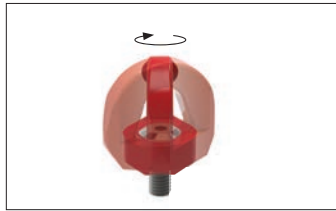

Single swivel - threads M8 – M48
loads 0,3 tons – 15 tons

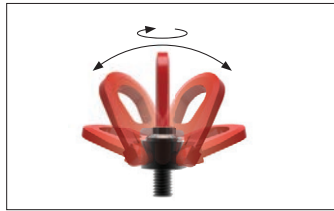

Double swivel - threads M4 – M100
loads 0,05 tons – 50 tons

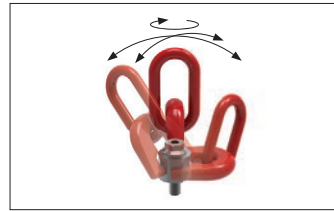

Triple swivel - threads M8 – M56
loads 0,3 tons – 22 tons

Pros

- ✓ Individual CE certification
- ✓ CE marked
- ✓ 100% physical check
- ✓ Proof load test of 2.5 x load limit
- ✓ Safety factor 5x stated load
- ✓ 100% traceability with individual marking
- ✓ Complies with 2006/42/CE
- ✓ Axial load
- ✓ Max. load bearing 90°
- ✓ Max. lateral load 90°
- ✓ Swivel loads
- ✓ Forces across lifting ring plane (double and triple swivel type)

Cons

Swivel lifting rings

Our swivel lifting rings fully comply with the EC directive 2006/42/EC. They are CE marked and are supplied with a Certificate of Conformity. There is a 100% check on anti-cracking, a proof load test of 2.5 x load limit and a safety factor of 5 on most parts. Each ring is individually marked to ensure full product traceability.

The Swivel Lifting Rings come in three main forms – depending on the number of axis required to swivel. The most popular type is the double swivel rings.

High tensile lifting rings

The High-tensile lifting bolts are similar to the standard lifting bolts but are rated at higher loads and can lift loads at up to 90° from the thread. They are not meant for loads that might swivel.

Important Note:

Forces must act in the direction of the lifting ring plane.

Standard lifting rings DIN580 and DIN582

These are CE marked and are available with male or female threads in either steel or stainless steel (A4 AISI 316). They are meant only for axial loads, or load bearing or lateral loads at a maximum of 45° from the thread. They are not for use under shear tension or loads (across the thread), nor for loads likely to swivel.

Applied forces must act in the direction of the eye bolt plane, do not apply forces across the eye bolt plane.

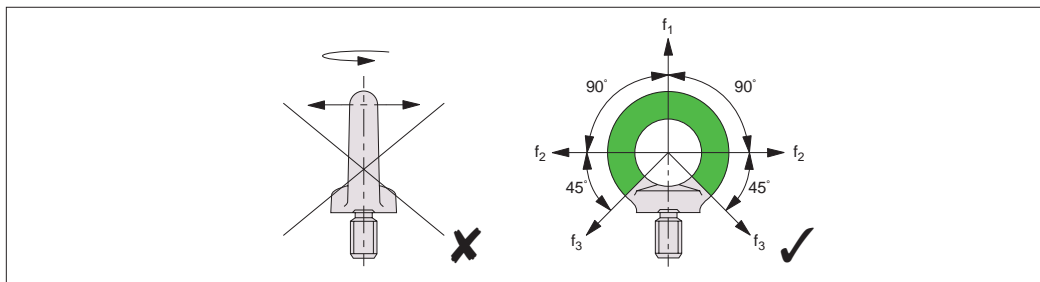

Pros

- ✓ CE marked
- ✓ Axial load
- ✓ Max. load bearing 90°
- ✓ Max. lateral load 90°

Cons

- ✗ Individual CE certification
- ✗ Shear tension
- ✗ Swivel loads
- ✗ Forces across lifting ring plane

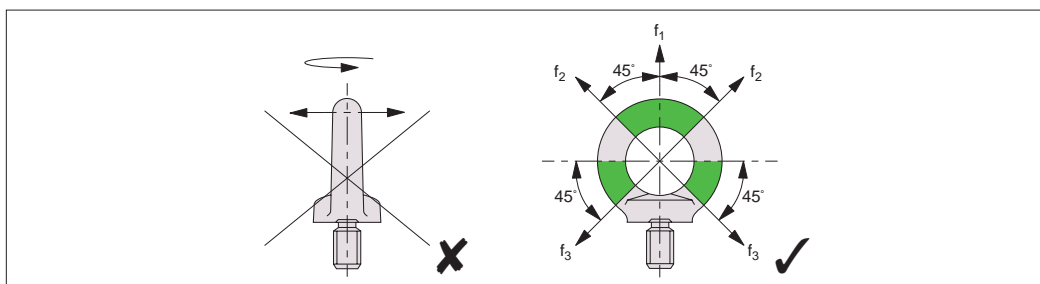

Pros

- ✓ CE marked
- ✓ Axial load
- ✓ Max. load bearing 45°
- ✓ Max. lateral load 45°









Cons

- ✗ Individual CE certification
- ✗ Shear tension
- ✗ Swivel loads
- ✗ Forces across lifting ring plane

Important Note: Forces must act in the direction of the lifting ring plane.



63020 Male

Lifting configuration	       								
	No. of rings	1	2	1	2	2	2	4	4
Lifting angle	0°	0°	90°	90°	45°	60°	45°	60°	
Thread	Maximum load rating for given lifting configuration								
M8 tons	0,30	0,60	0,30	0,60	0,40	0,30	0,60	0,30	
M10 tons	0,60	1,20	0,60	1,20	0,80	0,60	1,30	0,60	
M12 tons	1,00	2,00	1,00	2,00	1,40	1,00	2,10	1,00	
M16 tons	1,60	3,20	1,60	3,20	2,20	1,60	3,40	1,60	
M20 tons	2,50	5,00	2,50	5,00	3,50	2,50	5,30	2,50	
M24 tons	4,00	8,00	4,00	8,00	5,60	4,00	8,40	4,00	
M30 tons	6,30	12,60	6,30	12,60	8,80	6,30	13,20	6,30	
M36 tons	10,00	20,00	10,00	20,00	14,00	10,00	21,00	10,00	
M42 tons	12,50	25,00	12,50	25,00	17,50	12,50	26,30	12,50	
M48 tons	15,00	30,00	15,00	30,00	21,00	15,00	31,50	15,00	

Important Note: Table shows the maximum load rating for a given lifting configuration (NOT maximum load rating per individual lifting ring).



Swivel lifting rings



Single swivel - threads M8 – M48
loads 0,3 tons – 15 tons

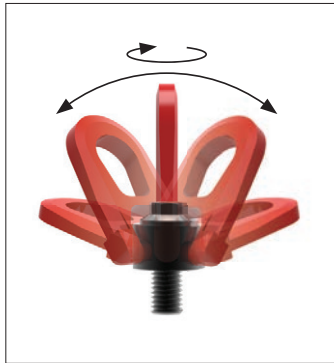

Double swivel - threads M4 – M100
loads 0,05 tons – 50 tons

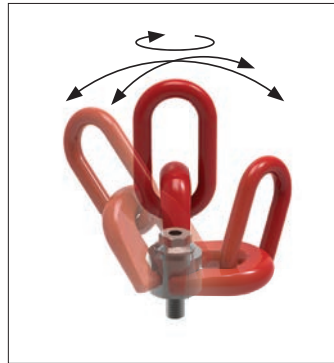

Triple swivel - threads M8 – M56
loads 0,3 tons – 22 tons

Our swivel lifting rings fully comply with the EC directive 2006/42/EC. They are CE marked and are supplied with a Certificate of Conformity. There is a 100% check on anti-cracking, a proof load test of 2.5 x load limit and a safety factor of 5 on most parts. Each ring is individually marked to ensure full product traceability. The Swivel Lifting Rings come in three main forms – depending on the number of axis required to swivel. The most popular type is the double swivel rings.

Steel and stainless steel (316) versions



Steel



Stainless (316L)

Compliant with 2006/42/EC, and with individual date of manufacture and batch number.

Product marking

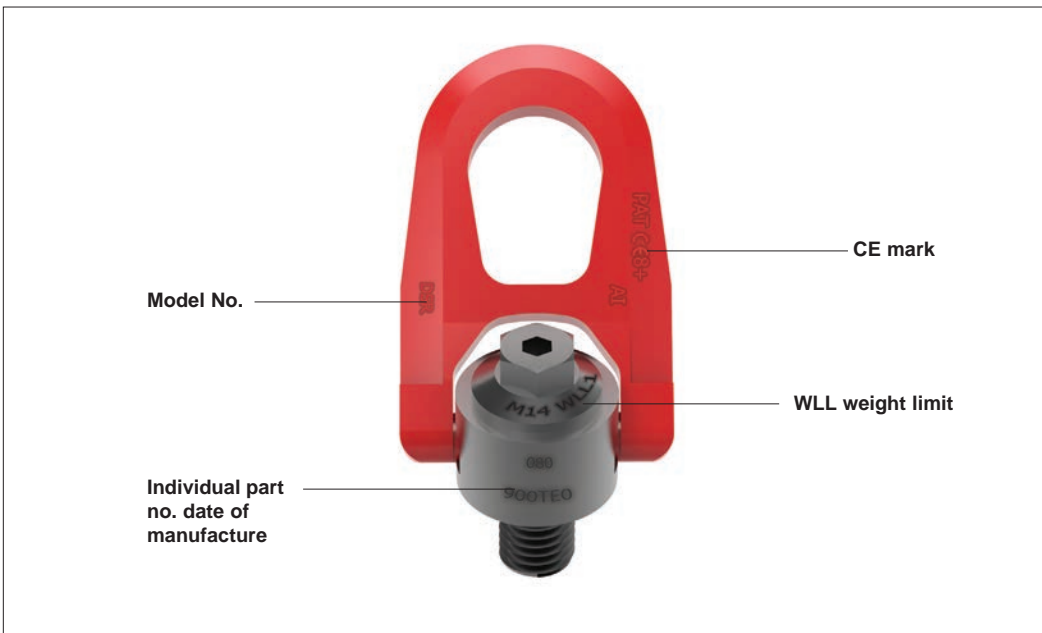

A swivel lifting rings that complies with 2006/42/CE

ov-W63020-AP4002-T-W63750-A-T-swivel-lifting-rings-introduction-mh- Updated -28-10-2022



63120 Male

Lifting configuration								
	α max. = 60°		α max. = 60°					
No. of rings	1	2	1	2	2	2	4	4
Lifting angle	0°	0°	90°	90°	45°	60°	45°	60°
Thread	Maximum load rating for given lifting configuration							
M 8 tons	0,30	0,60	0,30	0,60	0,40	0,30	0,60	0,30
M10 tons	0,60	1,20	0,60	1,20	0,80	0,60	1,30	0,60
M12 tons	1,00	2,00	1,00	2,00	1,40	1,00	2,10	1,00
M14 tons	1,30	2,60	1,30	2,60	1,80	1,30	2,70	1,30
M16 tons	1,60	3,20	1,60	3,20	2,20	1,60	3,40	1,60
M18 tons	2,00	4,00	2,00	4,00	2,80	2,00	4,20	2,00
M20 tons	2,50	5,00	2,50	5,00	3,50	2,50	5,30	2,50
(UNC 5/16"-18) lbs	650	1,300	650	1,300	910	650	1,365	650
(UNC 3/8"-16) lbs	1,200	2,400	1,200	2,400	1,680	1,200	2,520	1,200
(UNC 1/2"-13) lbs	2,200	4,400	2,200	4,400	3,080	2,200	4,620	2,200
(UNC 5/8"-11) lbs	3,800	7,600	3,800	7,600	5,320	3,800	7,980	3,800
(UNC 3/4"-10) lbs	5,500	11,000	5,500	11,000	7,700	5,500	11,550	5,500

Important note: Table shows the maximum load rating for a given lifting configuration (NOT maximum load rating per individual lifting ring).



Lifting Points - Double Swivel - Male standard bar - metric - coarse

Lifting Points & Shackles

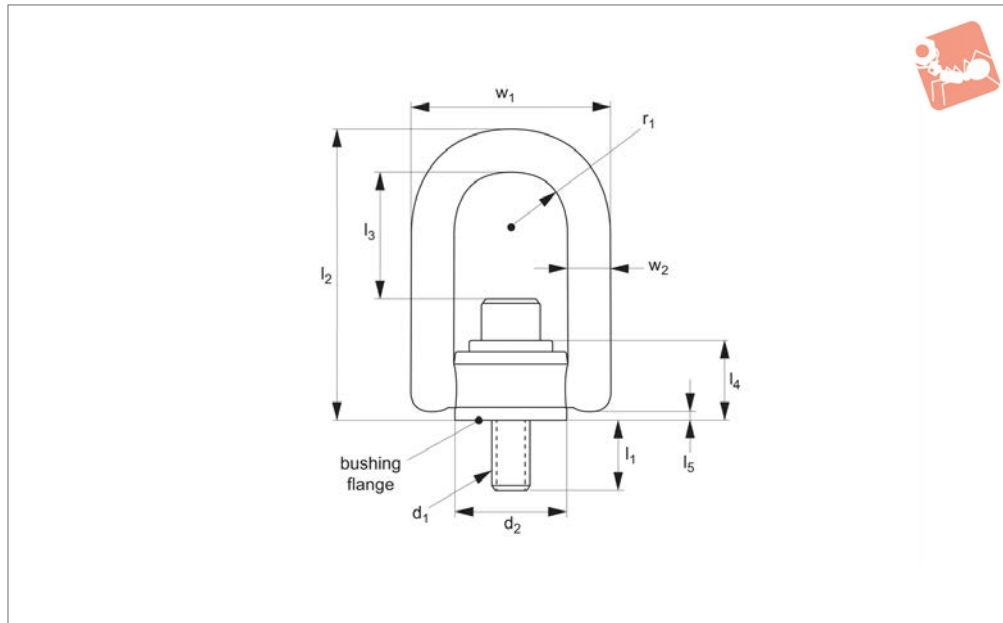

63501

LIFTING POINTS & SHACKLES

Material

Forged alloy steel (4140), min. tensile strength 180,000psi. Black oxide coated.

Technical Notes

Meets manufacturing and design require-

ments of ASME -B30.26 and MIL-STD 209. Magnetic particle inspected per ASTM 1444.

Tips

Min. design safety factor 5:1. 360° swivel

and 180° pivot underload. Each part individually serial numbered.

tl = recommended torque load (Nm).

Important Notes

Always follow safety instructions.

Order No.	Rated load tonnes (t)	d ₁	d ₂	l ₁	l ₂	l ₃	l ₄	l ₅	r ₁	w ₁	w ₂	tl Nm	Weight kg
63501.W0081	0.40	M 8x1,25	31.8	16	82.0	38.5	24.4	4.0	16.5	58.2	11.1	9.5	0.24
63501.W0082	0.40	M 8x1,25	31.8	21	82.0	38.5	24.4	4.0	16.5	58.2	11.1	9.5	0.25
63501.W0101	0.45	M10x1,50	31.8	16	82.0	36.5	24.4	4.0	16.5	58.2	11.1	16.0	0.25
63501.W0102	0.45	M10x1,50	31.8	26	82.0	36.5	24.4	4.0	16.5	58.2	11.1	16.0	0.26
63501.W0121	1.05	M12x1,75	48.0	25	134.9	65.0	38.1	4.4	25.4	88.9	19.1	37.0	0.78
63501.W0122	1.05	M12x1,75	48.0	32	134.9	65.0	38.1	4.4	25.4	88.9	19.1	37.0	0.83
63501.W0141	1.50	M14x2,00	48.0	25	135.2	65.0	38.1	4.4	25.4	88.9	19.1	45.0	0.79
63501.W0142	1.50	M14x2,00	48.0	32	135.2	65.0	38.1	4.4	25.4	88.9	19.1	45.0	0.84
63501.W0161	1.90	M16x2,00	48.0	25	134.9	62.0	38.1	4.4	25.4	88.9	19.1	80.0	0.81
63501.W0162	1.90	M16x2,00	48.0	32	134.9	62.0	38.1	4.4	25.4	88.9	19.1	80.0	0.85
63501.W0201	2.20	M20x2,50	48.0	25	134.9	58.7	38.1	4.4	25.4	88.9	19.1	135.0	0.86
63501.W0202	2.20	M20x2,50	48.0	38	134.9	58.7	38.1	4.4	25.4	88.9	19.1	135.0	0.92
63501.W0203	3.00	M20x2,50	71.4	28	187.2	89.7	52.1	4.6	35.6	129.5	25.4	135.0	3.14
63501.W0241	4.20	M24x3,00	71.4	28	187.2	85.7	52.1	4.6	35.6	129.5	25.4	311.0	3.29
63501.W0242	4.20	M24x3,00	71.4	38	187.2	85.7	52.1	4.6	35.6	129.5	25.4	311.0	3.30
63501.W0301	4.50	M30x3,50	71.4	38	187.2	79.7	52.1	4.6	35.6	129.5	25.4	311.0	3.44
63501.W0302	4.50	M30x3,50	71.4	48	187.2	79.7	52.1	4.6	35.6	129.5	25.4	311.0	3.55
63501.W0303	7.00	M30x3,50	98.5	67	234.2	92.5	72.9	8.2	50.8	171.5	31.8	637.2	7.26
63501.W0361	11.00	M36x4,00	98.5	67	234.2	98.5	72.9	8.2	50.8	171.5	31.8	88.6	8.21
63501.W0421	12.50	M42x4,50	98.5	80	234.2	98.5	72.9	8.2	50.8	171.5	31.8	88.6	10.14
63501.W0481	13.50	M48x5,00	98.5	80	234.2	98.5	72.9	8.2	50.8	171.5	31.8	88.6	10.59
63501.W0561	13.50	M56x5,50	98.5	88	234.2	98.5	72.9	8.2	50.8	171.5	31.8	88.6	11.03



63502

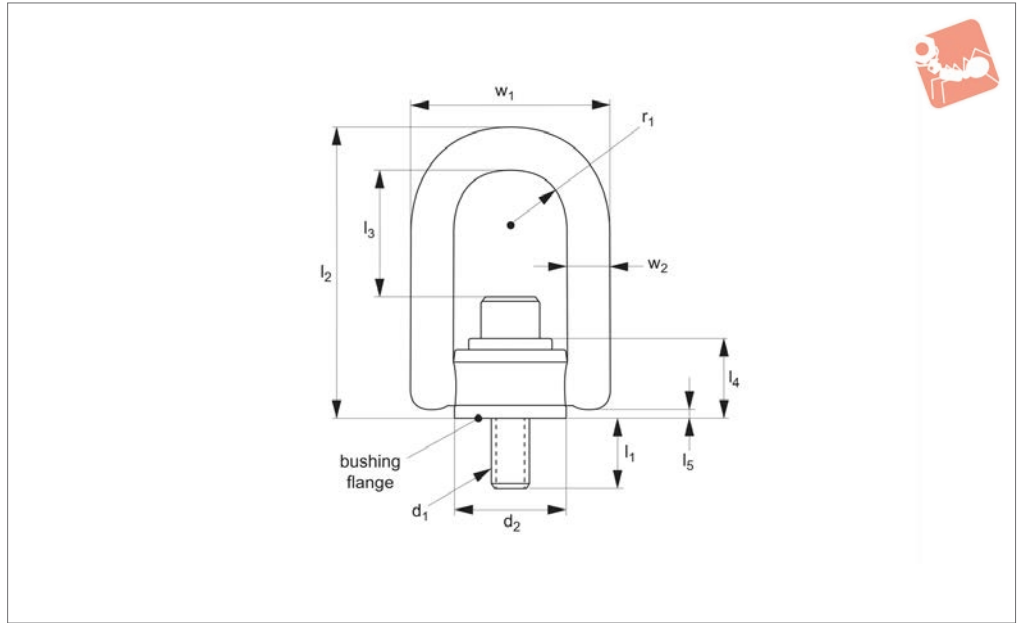

Material

Forged alloy steel (4140), min. tensile strength 180,000psi. Black oxide coated.

Technical Notes

Meets manufacturing and design require-

ments of ASME -B30.26 and MIL-STD 209. Magnetic particle inspected per ASTM 1444.

Tips

Min. design safety factor 5:1. 360° swivel

and 180° pivot underload. Each part individually serial numbered.

tl = recommended torque load (Nm).

Important Notes

Always follow safety instructions.

Order No.	Rated load tonnes (t)	d ₁	d ₂	l ₁	l ₂	l ₃	l ₄	l ₅	r ₁	w ₁	w ₂	tl Nm	Weight kg
63502.W0121	1.05	M12x1,75	48.0	25	174.6	104.7	38.1	4.4	25.4	88.9	19.1	37	0.93
63502.W0122	1.05	M12x,175	48.0	32	174.6	104.7	38.1	4.4	25.4	88.9	19.1	37	0.98
63502.W0141	1.50	M14x2,00	48.0	25	174.9	105.0	38.1	4.4	25.4	88.9	19.1	45	0.95
63502.W0142	1.50	M14x2,00	48.0	32	174.9	105.0	38.1	4.4	25.4	88.9	19.1	45	0.98
63502.W0161	1.90	M16x2,00	48.0	25	174.6	101.7	38.1	4.4	25.4	88.9	19.1	80	0.96
63502.W0162	1.90	M16x2,00	48.0	32	174.6	101.7	38.1	4.4	25.4	88.9	19.1	80	1.00
63502.W0201	2.20	M20x2,50	48.0	25	174.6	98.4	38.1	4.4	25.4	88.9	19.1	135	1.01
63502.W0202	2.20	M20x2,50	48.0	38	174.6	98.4	38.1	4.4	25.4	88.9	19.1	135	1.07
63502.W0203	3.00	M20x2,50	71.4	28	187.2	131.1	52.1	4.6	35.6	129.5	25.4	135	3.47
63502.W0241	4.20	M24x3,00	71.4	28	187.2	127.1	52.1	4.6	35.6	129.5	25.4	311	3.62
63502.W0242	4.20	M24x3,00	71.4	38	187.2	127.1	52.1	4.6	35.6	129.5	25.4	311	3.63
63502.W0301	4.50	M30x3,50	71.4	38	187.2	79.7	52.1	4.6	35.6	129.5	25.4	311	3.55



Lifting Points - Double Swivel - Male standard bar - UNC - thread

Lifting Points & Shackles

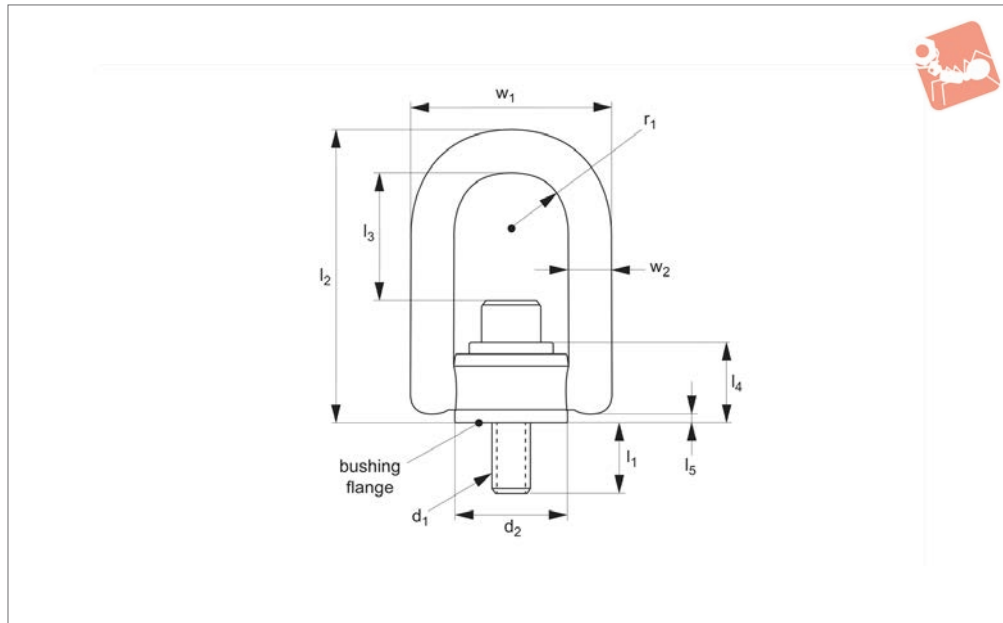

63511

LIFTING POINTS & SHACKLES

Material

Forged alloy steel (4140), min. tensile strength 180,000psi. Black oxide coated.

Technical Notes

Meets manufacturing and design requirements of ASME -B30.26 and MIL-STD 209.

Magnetic particle inspected per ASTM 1444.

Tips

Min. design safety factor 5:1. 360° swivel and 180° pivot underload. Each part individually serial numbered.

tl = recommended torque load (ft - lbs).

Important Notes

All dimensions in imperial.

Always follow safety instructions.

Order No.	Rated load lb	d ₁ UNC	d ₂	l ₁	l ₂	l ₃	l ₄	l ₅	r ₁	w ₁	w ₂	tl ft-lb	Weight lb
63511.W0251I	550	1/4-20	1.25	0.56	3.23	1.57	0.96	0.15	0.65	2.29	0.44	5	0.50
63511.W0311I	800	5/16-18	1.25	0.56	3.23	1.51	0.96	0.15	0.65	2.29	0.44	7	0.52
63511.W0312I	800	5/16-18	1.25	1.06	3.23	1.51	0.96	0.15	0.65	2.29	0.44	7	0.54
63511.W0371I	1000	3/8-16	1.25	0.56	3.23	1.45	0.96	0.15	0.65	2.29	0.44	12	0.56
63511.W0342I	1000	3/8-16	1.25	1.06	3.23	1.45	0.96	0.15	0.65	2.29	0.44	12	0.58
63511.W0501I	2250	1/2-13	1.25	1.06	3.23	1.45	0.96	0.15	0.65	2.29	0.44	25	0.60
63511.W0502I	2500	1/2-13	1.89	0.75	5.31	2.56	1.50	0.17	1.00	3.50	0.75	28	1.71
63511.W0503I	2500	1/2-13	1.89	1.00	5.31	2.56	1.50	0.17	1.00	3.50	0.75	28	1.72
63511.W0504I	2500	1/2-13	1.89	1.25	5.31	2.56	1.50	0.17	1.00	3.50	0.75	28	1.82
63511.W0631I	4000	5/8-11	1.89	0.75	5.31	2.44	1.50	0.17	1.00	3.50	0.75	60	1.76
63511.W0632I	4000	5/8-11	1.89	1.00	5.31	2.44	1.50	0.17	1.00	3.50	0.75	60	1.78
63511.W0633I	4000	5/8-11	1.89	1.25	5.31	2.44	1.50	1.89	1.00	3.50	0.75	60	1.88
63511.W0751I	5000	3/4-10	1.89	1.00	5.31	2.31	1.50	0.17	1.00	3.50	0.75	100	1.89
63511.W0752I	5000	3/4-10	1.89	1.50	5.31	2.31	1.50	0.17	1.00	3.50	0.75	100	2.02
63511.W0754I	7000	3/4-10	2.81	1.20	7.37	3.57	2.05	0.18	1.40	5.10	1.00	100	7.23
63511.W0755I	7000	3/4-10	2.81	1.45	7.37	3.57	2.05	0.18	1.40	5.10	1.00	100	7.25
63511.W0881I	8000	7/8-9	2.81	0.95	7.37	3.32	2.05	0.18	1.40	5.10	1.00	160	7.33
63511.W0882I	8000	7/8-9	2.81	1.20	7.37	3.32	2.05	0.18	1.40	5.10	1.00	160	7.33
63511.W1001I	10000	1-8	2.81	1.45	7.37	3.20	2.05	0.18	1.40	5.10	1.00	230	7.57
63511.W1002I	10000	1-8	2.81	1.20	7.37	3.20	2.05	0.18	1.40	5.10	1.00	230	7.63
63511.W1003I	10000	1-8	2.81	2.20	7.37	3.20	2.05	0.18	1.40	5.10	1.00	230	7.81
63511.W1251I	15000	1-1/4-7	3.88	1.88	9.22	3.74	2.87	0.18	2.00	6.75	1.25	470	15.74
63511.W1252I	15000	1-1/4-7	3.88	2.63	9.22	3.74	2.87	0.18	2.00	6.75	1.25	470	16.00
63511.W1501I	24000	1-1/2-6	3.88	2.63	9.22	3.49	2.87	0.32	2.00	6.75	1.25	800	18.10
63511.W2001I	30000	2-4-1/2	3.88	2.96	9.22	3.49	2.87	0.32	2.00	6.75	1.25	1100	22.90
63511.W2002I	30000	2-8	3.88	2.96	9.22	3.49	2.87	0.32	2.00	6.75	1.25	1100	22.90



63512

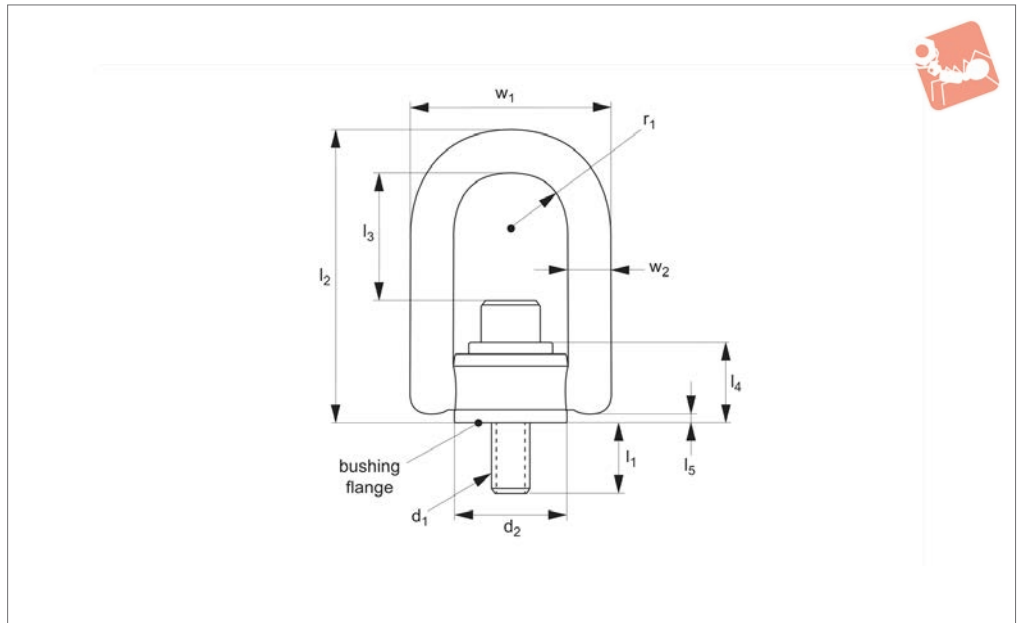

Material

Forged alloy steel (4140), min. tensile strength 180,000psi. Black oxide coated.

Technical Notes

Meets manufacturing and design requirements of ASME -B30.26 and MIL-STD 209.

Magnetic particle inspected per ASTM 1444.

Tips

Min. design safety factor 5:1. 360° swivel and 180° pivot underload. Each part individually serial numbered.

tl = recommended torque load (ft - lbs.)

Important Notes

All dimensions in imperial.

Always follow safety instructions.

Order No.	Rated load lb	d ₁ UNC	d ₂	l ₁	l ₂	l ₃	l ₄	l ₅	r ₁	w ₁	w ₂	tl ft-lb	Weight lb
63512.W0501I	2500	1/2-13	1.89	0.75	6.87	4.12	1.50	0.17	1.0	3.5	0.75	28	2.04
63512.W0502I	2500	1/2-13	1.89	1.00	6.87	4.12	1.50	0.17	1.0	3.5	0.75	28	2.05
63512.W0503I	2500	1/2-13	1.89	1.25	6.87	4.12	1.50	0.17	1.0	3.5	0.75	28	2.15
63512.W0631I	4000	5/8-11	1.89	0.75	6.87	4.00	1.50	0.17	1.0	3.5	0.75	60	2.09
63512.W0632I	4000	5/8-11	1.89	1.00	6.87	4.00	1.50	0.17	1.0	3.5	0.75	60	2.11
63512.W0633I	4000	5/8-11	1.89	1.25	6.87	4.00	1.50	0.17	1.0	3.5	0.75	60	2.21
63512.W0751I	5000	3/4-10	1.89	1.00	6.87	3.87	1.50	0.17	1.0	3.5	0.75	100	2.22
63512.W0752I	5000	3/4-10	1.89	1.50	6.87	3.87	1.50	0.17	1.0	3.5	0.75	100	2.35
63512.W0753I	7000	3/4-10	2.81	0.95	9.00	5.20	2.05	0.18	1.4	5.1	1.00	100	7.93
63512.W0754I	7000	3/4-10	2.81	1.20	9.00	5.20	2.05	0.18	1.4	5.1	1.00	100	7.96
63512.W0755I	7000	3/4-10	2.81	1.45	9.00	5.20	2.05	0.18	1.4	5.1	1.00	100	7.98
63512.W0881I	8000	7/8-9	2.81	0.95	9.00	4.95	2.05	0.18	1.4	5.1	1.00	160	8.06
63512.W0882I	8000	7/8-9	2.81	1.20	9.00	4.82	2.05	0.18	1.4	5.1	1.00	160	8.06
63512.W1001I	10000	1-8	2.81	1.45	9.00	4.82	2.05	0.18	1.4	5.1	1.00	230	8.30
63512.W1002I	10000	1-8	2.81	1.20	9.00	4.82	2.05	0.18	1.4	5.1	1.00	230	8.36
63512.W1003I	10000	1-8	2.81	2.20	9.00	4.82	2.05	0.18	1.4	5.1	1.00	230	8.54



Lifting Points - Double Swivel - Male standard bar - metric - coarse

Lifting Points & Shackles

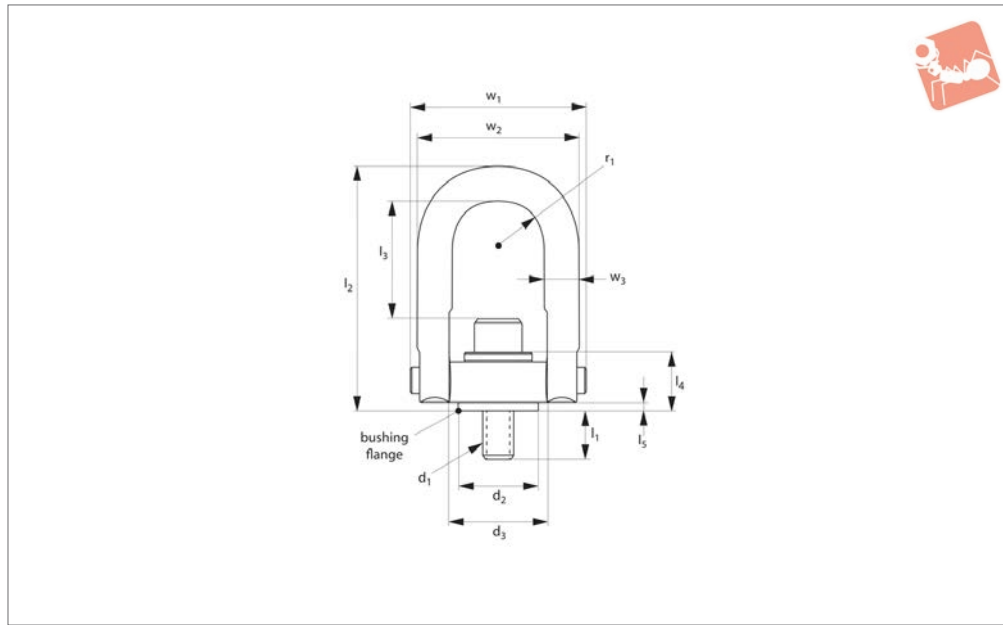

63521

LIFTING POINTS & SHACKLES

Material

Forged alloy steel (4140), min. tensile strength 180,000psi. Black oxide coated.

ments of ASME -B30.26 and MIL-STD 209. Magnetic particle inspected per ASTM 1444.

and 180° pivot underload. Each part individually serial numbered.

Technical Notes

Meets manufacturing and design require-

Tips

Min. design safety factor 5:1. 360° swivel

Important Notes

Always follow safety instructions.

Order No.	Rated load tonnes (t)	d ₁	d ₂	d ₃	l ₁	l ₂	l ₃	l ₄	Weight kg
63521.W0081	0.40	M 8x1,25	19.10	25.40	17	67.80	32.10	18.0	0.14
63521.W0101	0.45	M10x1,50	19.10	25.40	17	67.80	30.20	18.0	0.14
63521.W0121	1.05	M12x1,75	38.00	50.50	19	121.40	59.40	31.0	1.05
63521.W0161	1.90	M16x2,00	38.00	50.50	24	121.40	55.40	31.0	1.11
63521.W0201	2.20	M20x2,50	38.00	50.50	30	121.40	51.40	31.0	1.16
63521.W0202	3.00	M20x2,50	58.70	76.20	29	165.80	77.00	43.4	3.06
63521.W0241	4.20	M24x3,00	58.70	76.20	34	165.80	73.00	43.4	3.18
63521.W0301	4.50	M30x3,50	58.70	76.20	54	165.80	67.00	43.4	3.30
63521.W0302	7.00	M30x3,50	81.30	95.50	46	221.70	106.30	53.6	6.36
63521.W0303	7.00	M30x3,50	81.30	95.50	66	221.70	106.30	53.6	6.70
63521.W0361	11.00	M36x4,00	106.70	123.70	69	316.70	164.80	71.4	15.34
63521.W0421	12.50	M42x4,50	106.70	123.70	79	316.70	158.80	71.4	15.91
63521.W0481	13.50	M48x5,00	106.70	123.70	79	316.70	152.80	71.4	16.36
63521.W0641	22.00	M64x6,00	146.10	165.60	102	428.50	230.30	104.0	39.77
63521.W0721	31.50	M72x6,00	184.15	205.74	132	495.30	215.39	133.9	75.45
63521.W0901	51.00	M90x6,00	196.85	218.44	178	561.09	235.71	153.9	109.09

Order No.	l ₅	r ₁	w ₁	w ₂	w ₃	tl Nm
63521.W0081	4.30	10.90	46.70	40.9	9.50	9.5
63521.W0101	4.30	10.90	46.70	40.9	9.50	16.0
63521.W0121	4.10	22.40	89.40	82.5	19.00	37.0
63521.W0161	4.10	22.40	89.40	82.5	19.00	80.0
63521.W0201	4.10	22.40	89.40	82.5	19.00	135.0
63521.W0202	6.10	35.60	130.50	121.2	25.40	135.0
63521.W0241	6.10	35.60	130.50	121.2	25.40	311.0
63521.W0301	6.10	35.60	130.50	121.2	25.40	311.0
63521.W0302	8.90	44.50	165.10	152.4	31.80	637.2
63521.W0303	8.90	44.50	165.10	152.4	31.80	637.2
63521.W0361	11.90	57.20	217.20	203.2	44.50	1085.5
63521.W0421	11.90	57.20	217.20	203.2	44.50	1085.5
63521.W0481	11.90	57.20	217.20	203.2	44.50	1085.5



Order No.	l_5	r_1	w_1	w_2	w_3	tl Nm
63521.W0641	28.40	76.20	296.40	266.7	57.20	2847.5
63521.W0721	25.40	95.25	368.30	330.2	69.85	5670.0
63521.W0901	27.69	101.60	403.86	368.3	82.55	9560.0



Lifting Points - Double Swivel - Male

long bar - metric - coarse

Lifting Points & Shackles

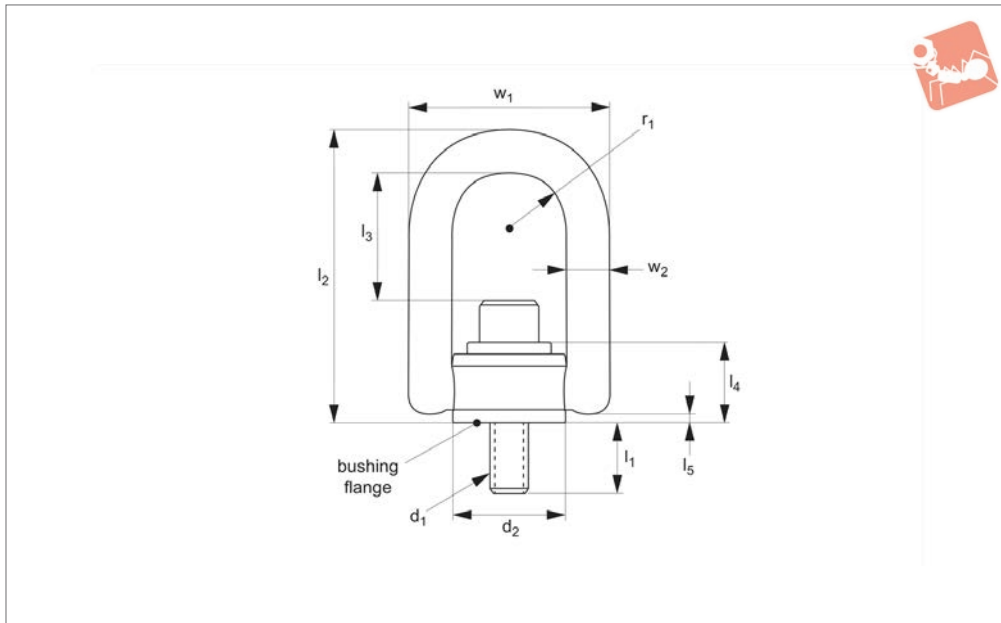

63522

LIFTING POINTS & SHACKLES

Material

Forged alloy steel (4140), min. tensile strength 180,000psi. Black oxide coated.

Technical Notes

Meets manufacturing and design require-

ments of ASME -B30.26 and MIL-STD 209. Magnetic particle inspected per ASTM 1444.

Tips

Min. design safety factor 5:1. 360° swivel

and 180° pivot underload. Each part individually serial numbered.

tl = recommended torque load (Nm.)

Important Notes

Always follow safety instructions.

Order No.	Rated load tonnes (t)	d ₁	d ₂	d ₃	l ₁	l ₂	l ₃	l ₄	l ₅	r ₁	w ₁	w ₂	w ₃	tl Nm	Weight kg
63522.W0121	1.05	M12x1,75	38.0	50.5	19	121.4	108.6	31.0	4.1	22.4	89.4	82.5	19.0	37	1.27
63522.W0161	1.90	M16x2,00	38.0	50.5	24	121.4	104.8	31.0	4.1	22.4	89.4	82.5	19.0	80	1.33
63522.W0201	2.20	M20x2,50	38.0	50.5	30	121.4	100.6	31.0	4.1	22.4	89.4	82.5	19.0	135	1.38
63522.W0202	3.00	M20x2,50	58.7	76.2	29	165.8	177.9	43.4	6.1	35.6	160.5	121.2	25.4	135	3.77
63522.W0241	4.20	M24x3,00	58.7	76.2	34	165.8	113.9	43.4	6.1	35.6	160.5	121.2	25.4	311	3.89
63522.W0301	4.50	M30x3,50	58.7	76.2	54	165.8	109.9	43.4	6.1	35.6	160.5	121.2	25.4	311	4.01



63531

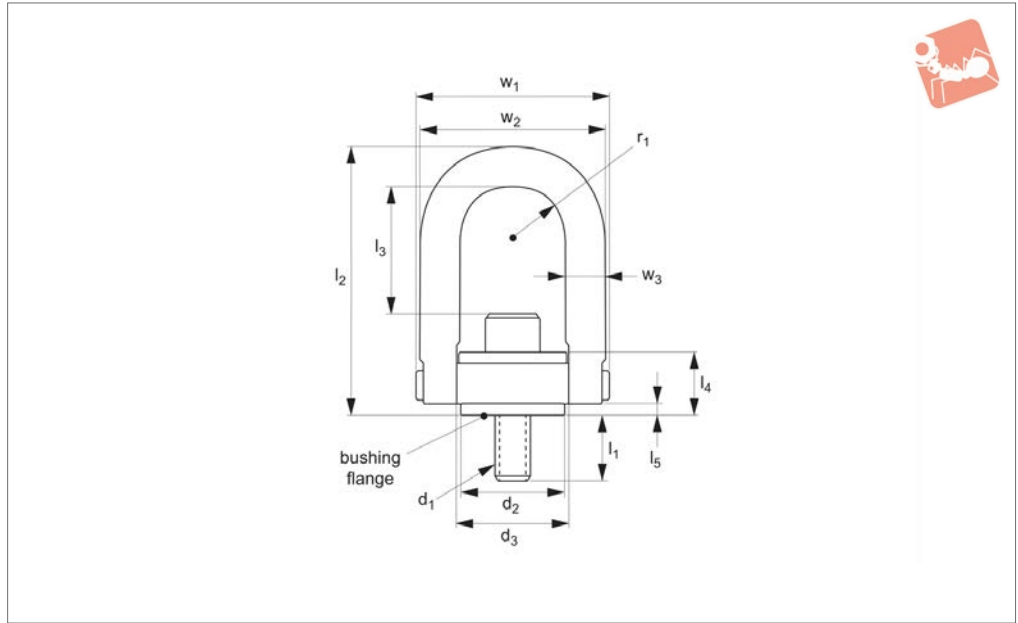

LIFTING POINTS & SHACKLES

Material

Forged alloy steel (4140), min. tensile strength 180,000psi. Black oxide coated.

Technical Notes

Meets manufacturing and design requirements of ASME -B30.26 and MIL-STD 209.

Magnetic particle inspected per ASTM 1444.

Tips

Min. design safety factor 5:1. 360° swivel and 180° pivot underload. Each part individually serial numbered.

tl = recommended torque load (ft - lbs)

Important Notes

All dimensions in imperial.

Always follow safety instructions.

Order No.	Rated load lb	d ₁	d ₂	d ₃	l ₁	l ₂	Weight lb
63531.W0251I	550	1/4-20	0.75	1.00	0.54	2.67	0.31
63531.W0311I	800	5/16-18	0.75	1.00	0.29	2.67	0.31
63531.W0312I	800	5/16-18	0.75	1.00	0.54	2.67	0.31
63531.W0371I	1000	3/8-16	0.75	1.00	0.54	2.67	0.31
63531.W0501I	2500	1/2-13	1.25	1.49	1.07	3.77	0.31
63531.W0502I	2500	1/2-13	1.50	1.99	0.78	4.78	2.31
63531.W0503I	2500	1/2-13	1.50	1.99	1.03	4.78	2.31
63531.W0504I	2500	1/2-13	1.50	1.99	1.28	4.78	2.31
63531.W0631I	4000	5/8-11	1.50	1.99	0.78	4.78	2.43
63531.W0632I	4000	5/8-11	1.50	1.99	1.03	6.72	2.43
63531.W0634I	4000	5/8-11	1.50	1.99	1.28	6.72	2.43
63531.W0751I	5000	3/4-10	1.50	1.99	1.03	6.72	2.56
63531.W0752I	5000	3/4-10	1.50	1.99	1.53	6.72	2.56
63531.W0753I	7000	3/4-10	2.37	3.00	1.04	6.52	6.62
63531.W0754I	7000	3/4-10	2.37	3.00	1.54	6.52	6.62
63531.W0881I	8000	7/8-9	2.37	3.00	1.04	6.52	6.75
63531.W1001I	10000	1-8	2.37	3.00	1.29	6.52	7.00
63531.W1002I	10000	1-8	2.37	3.00	1.54	6.52	7.00
63531.W1003I	10000	1-8	2.37	3.00	2.29	6.52	7.00
63531.W1251I	15000	1-1/4-7	3.20	3.76	1.89	8.73	7.00
63531.W1501I	24000	1-1/2-6	4.20	4.87	2.70	12.47	33.75
63531.W2001I	30000	2-4-1/4	4.20	4.87	2.96	12.47	36.00
63531.W2002I	30000	2-4-1/2	4.20	4.87	2.96	12.47	36.00
63531.W2501I	50000	2-1/2-8	5.75	6.52	4.00	16.87	87.50
63531.W2502I	50000	2-1/2-4	5.75	6.52	4.00	16.87	87.50
63531.W3001I	75000	3-4	7.25	8.10	5.20	19.50	166.00
63531.W3501I	100000	3-1/2-4	7.75	8.60	7.00	22.09	240.00
63531.W4251I	150000	4-1/4-4	9.87	10.75	8.50	27.38	525.00
63531.W5001I	200000	5-4	12.38	13.00	9.00	33.00	760.00
63531.W6001I	250000	6-4	12.38	13.00	9.00	33.00	841.00



Lifting Points - Double Swivel - Male standard bar - UNC thread

Lifting Points & Shackles



Order No.	l ₃	l ₄	l ₅	r ₁	w ₁	w ₂	w ₃	tl ft-lb
63531.W0251I	1.33	0.71	0.17	0.43	1.84	1.61	3/8	5
63531.W0311I	1.27	0.71	0.17	0.43	1.84	1.61	3/8	7
63531.W0312I	1.27	0.71	0.17	0.43	1.84	1.61	3/8	7
63531.W0371I	1.21	0.71	0.17	0.43	1.84	1.61	3/8	12
63531.W0501I	1.84	0.93	0.20	0.70	2.58	2.40	1/2	28
63531.W0502I	2.31	1.22	0.16	0.88	3.52	3.25	3/4	28
63531.W0503I	2.31	1.22	0.16	0.88	3.52	3.25	3/4	28
63531.W0504I	2.31	1.22	0.16	0.88	3.52	3.25	3/4	28
63531.W0631I	2.18	1.22	0.16	0.88	3.52	3.25	3/4	60
63531.W0632I	2.18	1.22	0.16	0.88	3.52	3.25	3/4	60
63531.W0634I	2.18	1.22	0.16	0.88	3.52	3.25	3/4	60
63531.W0751I	2.06	1.22	0.16	0.88	3.52	3.25	3/4	100
63531.W0752I	2.06	1.22	0.16	0.88	3.52	3.25	3/4	100
63531.W0753I	3.06	1.71	0.24	1.40	5.14	4.80	1	100
63531.W0754I	3.06	1.71	0.24	1.40	5.14	4.80	1	100
63531.W0881I	2.93	1.71	0.24	1.40	5.14	4.80	1	160
63531.W1001I	2.81	1.71	0.24	1.40	5.14	4.80	1	230
63531.W1002I	2.81	1.71	0.24	1.40	5.14	4.80	1	230
63531.W1003I	2.81	1.71	0.24	1.40	5.14	4.80	1	230
63531.W1251I	4.12	2.11	0.35	1.75	6.50	6.00	1-1/4	470
63531.W1501I	6.41	2.81	0.47	2.25	8.55	8.00	1-3/4	800
63531.W2001I	5.41	2.81	0.47	2.25	8.55	8.00	1-3/4	1100
63531.W2002I	5.41	2.81	0.47	2.25	8.55	8.00	1-3/4	1100
63531.W2501I	8.03	4.09	1.12	3.00	11.67	10.50	2-1/4	2100
63531.W2502I	8.03	4.09	1.12	3.00	11.67	10.50	2-1/4	2100
63531.W3001I	8.48	5.27	1.00	3.75	14.15	13.00	2-3/4	4300
63531.W3501I	9.28	6.06	1.09	4.00	15.90	14.50	3-1/4	6600
63531.W4251I	12.13	7.50	1.33	5.00	19.69	18.00	4	12000
63531.W5001I	14.50	9.00	1.38	6.00	24.00	22.00	5	19800
63531.W6001I	14.00	9.00	1.88	6.00	24.00	22.00	5	29000

LIFTING POINTS & SHACKLES



63532

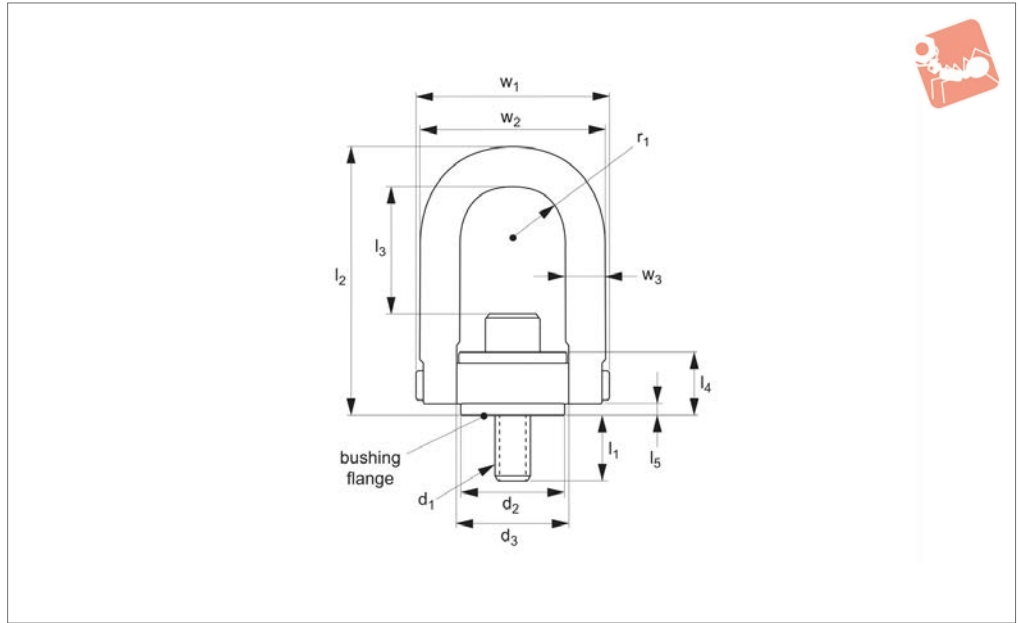

Material

Forged alloy steel (4140), min. tensile strength 180,000psi. Black oxide coated.

Technical Notes

Meets manufacturing and design requirements of ASME -B30.26 and MIL-STD 209.

Magnetic particle inspected per ASTM 1444.

Tips

Min. design safety factor 5:1. 360° swivel and 180° pivot underload. Each part individually serial numbered.

tl = recommended torque load (ft - lbs)

Important Notes

All dimensions in imperial.

Always follow safety instructions.

Order No.	Rated load lb	d ₁	d ₂	d ₃	l ₁	l ₂	l ₃	Weight lb
63532.W0501I	2500	1/2-13	1.50	1.99	0.780	6.72	4.25	2.75
63532.W0502I	2500	1/2-13	1.50	1.99	0.103	6.72	4.25	2.00
63532.W0503I	2500	1/2-13	1.50	1.99	1.280	6.72	4.25	2.75
63532.W0631I	4000	5/8-11	1.50	1.99	1.030	4.38	4.12	2.87
63532.W0632I	4000	5/8-11	1.50	1.99	1.280	4.38	4.12	2.87
63532.W0751I	5000	3/4-10	1.50	1.99	1.030	4.38	4.00	3.00
63532.W0752I	5000	3/4-10	1.50	1.99	1.530	4.38	4.00	3.00
63532.W0753I	7000	3/4-10	2.37	3.00	1.040	8.11	4.65	7.25
63532.W0754I	7000	3/4-10	2.37	3.00	1.540	8.11	4.65	6.62
63532.W0881I	8000	7/8-9	2.37	3.00	1.040	8.11	4.52	6.75
63532.W1001I	10000	1-8	2.37	3.00	1.290	8.11	4.40	7.00
63532.W1002I	10000	1-8	2.37	3.00	1.540	8.11	4.40	7.00
63532.W1003I	10000	1-8	2.37	3.00	2.290	8.11	4.40	7.00

Order No.	l ₄	l ₅	r ₁	w ₁	w ₂	w ₃	tl ft-lb
63532.W0501I	1.22	0.16	0.88	3.52	3.25	3/4	28
63532.W0502I	1.22	0.16	0.88	3.52	3.25	3/4	28
63532.W0503I	1.22	0.16	0.88	3.52	3.25	3/4	28
63532.W0631I	1.22	0.16	0.88	3.52	3.25	3/4	60
63532.W0632I	1.22	0.16	0.88	3.52	3.25	3/4	60
63532.W0751I	1.22	0.16	0.88	3.52	3.25	3/4	100
63532.W0752I	1.22	0.16	0.88	3.52	3.25	3/4	100
63532.W0753I	1.71	0.24	1.40	5.14	4.80	1	100
63532.W0754I	1.71	0.24	1.40	5.14	4.80	1	100
63532.W0881I	1.71	0.24	1.40	5.14	4.80	1	160
63532.W1001I	1.71	0.24	1.40	5.14	4.80	1	230
63532.W1002I	1.71	0.24	1.40	5.14	4.80	1	230
63532.W1003I	1.71	0.24	1.40	5.14	4.80	1	230



Lifting Points - Double Swivel - Male

easy torque - metric - coarse

Lifting Points & Shackles

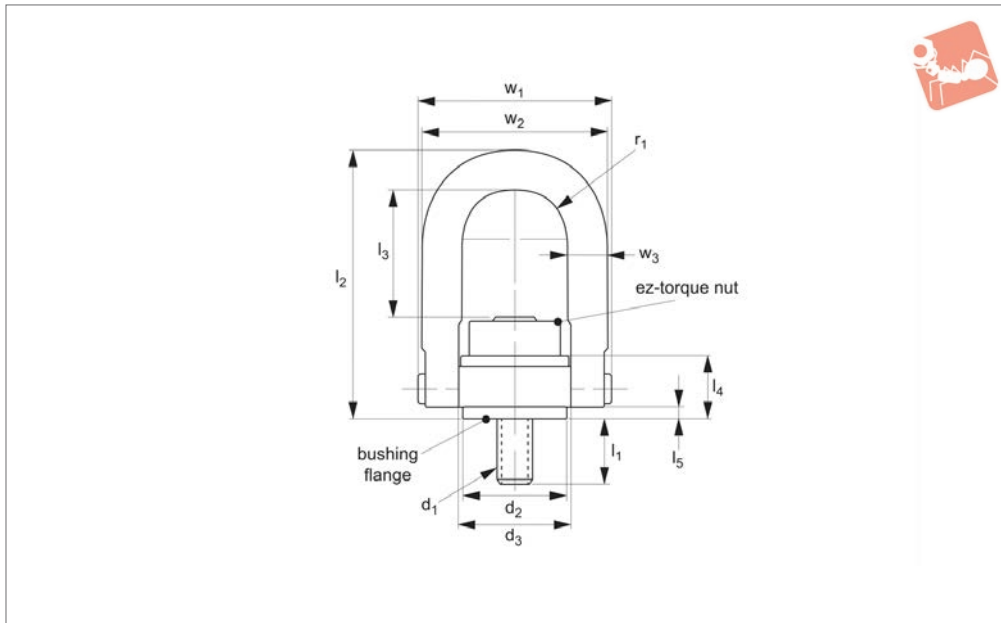

63591

LIFTING POINTS & SHACKLES

Material

Forged alloy steel (4140) min. tensile strength 180,000 psi. Black oxide coated.

Tips

EZ-torque hoist rings greatly reduce the required torque load (tl) for installation. Unique EZ-torque nut means hoist ring

requires only a standard torque wrench for installation, e.g EZ-torque hoist ring M30x3.5 requires only 13,5 Nm of torque, while a comparable standard hoist ring would require over 637 Nm.

Important Notes

Min. design safety factor 5:1. 360° swivel

180° pivot under load.

Individually serial numbered.

tl- recommended torque load (Nm.) for installation.

Always follow safety instructions.

Order No.	Rated load tonnes (t)	d ₁	d ₂	d ₃	l ₁	l ₂	l ₃	Weight kg
63591.W0301	7.00	M30x3,5	81.3	95.5	66	221.7	106.3	7.26
63591.W0361	11.00	M36x4,0	106.7	123.7	69	316.7	164.8	17.13
63591.W0421	12.50	M42x4,5	106.7	123.7	79	316.7	158.8	17.13
63591.W0481	13.50	M48x5,0	106.7	123.7	79	316.7	152.8	17.69
63591.W0641	22.00	M64x6,0	146.1	165.6	102	428.5	203.3	41.73
63591.W0721	31.50	M72x6,0	184.1	205.7	132	495.3	215.4	79.20
63591.W0901	51.00	M90x6,0	196.8	218.4	178	651.1	235.7	112.01

Order No.	l ₄	l ₅	r ₁	w ₁	w ₂	w ₃	tl Nm
63591.W0301	53.6	8.9	44.5	165.1	152.4	31.8	23.5
63591.W0361	71.4	11.9	57.2	217.2	203.2	44.5	20.8
63591.W0421	71.4	11.9	57.2	217.2	203.2	44.5	21.6
63591.W0481	71.4	11.9	57.2	217.2	203.2	44.5	21.3
63591.W0641	104.0	28.4	76.2	296.4	266.7	57.2	53.9
63591.W0721	133.9	25.4	95.2	368.3	330.2	69.8	124.7
63591.W0901	153.9	27.7	101.6	403.9	368.3	82.5	132.8



63592

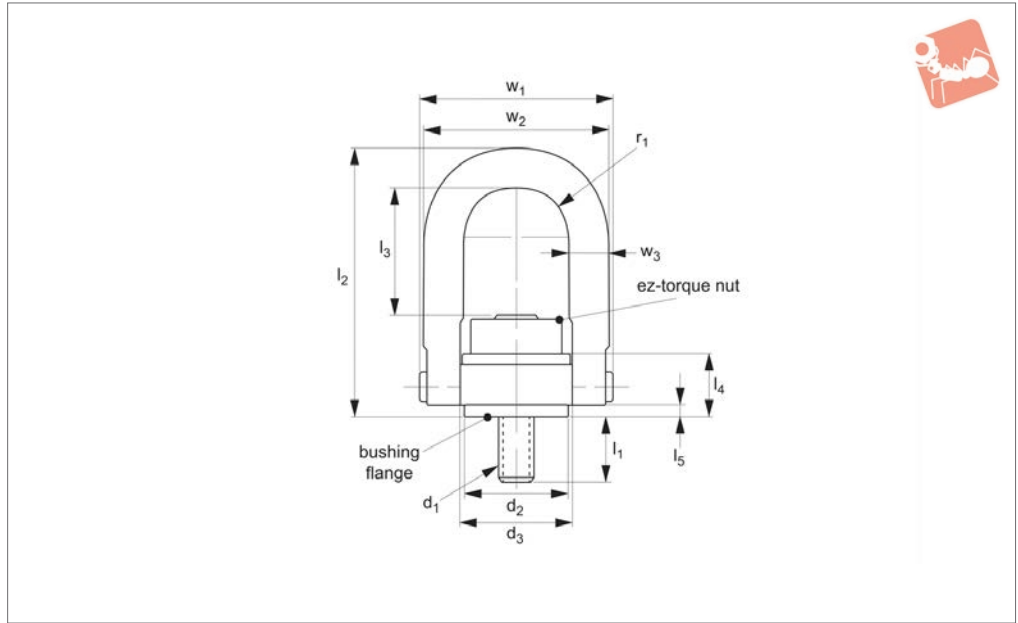

LIFTING POINTS & SHACKLES

Material

Forged alloy steel (4140) min. tensile strength 180,000 psi. Black oxide coated.

Technical Notes

Min. design safety factor 5:1. 360° swivel 180° pivot under load. Individually serial numbered.

tl- recommended torque load (Nm) for installation.

Tips

EZ-torque hoist rings greatly reduce the required torque load (tl) for installation. Unique EZ-torque nut means hoist ring requires only a standard torque wrench for

installation, e.g EZ-torque hoist ring M30x3,5 requires only 13,5 ft - lbs of torque, while a comparable standard hoist ring would require over 637 ft - lbs.

Important Notes

All dimensions in imperial.
Always follow safety instructions.

Order No.	Rated load lb	d ₁ UNC	d ₂	d ₃	l ₁	l ₂	l ₃	Weight lb
63592.W1251I	15000	1-1/4-7	3.20	3.76	1.89	8.73	3.88	16.00
63592.W1501I	24000	1-1/2-6	4.20	4.87	2.70	12.47	6.12	37.37
63592.W2001I	30000	2-4-1/2	4.20	4.87	2.96	12.47	6.12	39.00
63592.W2501I	50000	2-1/2-8	5.75	6.52	4.00	16.87	7.73	92.00
63592.W2502I	50000	2-1/2-4	5.75	6.52	4.00	16.87	7.73	92.00
63592.W3001I	75000	3-4	7.25	8.10	5.20	19.50	8.53	174.60
63592.W3501I	100000	3-1/2-4	7.75	8.60	7.00	22.09	9.28	246.94
63592.W4251I	150000	4 1/4-4	9.87	10.75	8.50	27.38	12.93	527.00
63592.W5001I	200000	5-4	12.38	13.00	9.00	33.00	15.00	763.00
63592.W6001I	250000	6-4	12.38	13.00	9.00	33.00	15.00	841.00

Order No.	l ₄	l ₅	r ₁	w ₁	w ₂	w ₃	tl ft-lb
63592.W1251I	2.11	0.35	1.75	6.50	6.0	1-1/4	10
63592.W1501I	2.81	0.47	2.25	8.55	8.0	1-3/4	18
63592.W2001I	2.81	0.47	2.25	8.55	8.0	1-3/4	23
63592.W2501I	4.09	1.12	3.00	11.67	10.5	2-1/4	49
63592.W2502I	4.09	1.12	3.00	11.67	10.5	2-1/4	49
63592.W3001I	5.27	1.00	3.75	14.15	13.0	2-3/4	92
63592.W3501I	6.06	1.09	4.00	15.90	14.5	3-1/4	98
63592.W4251I	7.50	1.33	5.00	19.69	18.0	4	123
63592.W5001I	9.00	1.88	6.00	24.00	22.0	5	193
63592.W6001I	9.00	1.88	6.00	24.00	22.0	5	207



Heavy duty safety hoist rings are stronger than competitive lifting devices, providing better value while delivering the quality and safety only the best design and manufacture can achieve.

- Manufactured from high strength alloy steel.
- One piece body and shouldered d-ring element.
- Just 6 component parts for increased safety.

The patented shoulder pin used in our heavy duty safety hoist rings allows for rotation of the pin, without shearing of any retaining dowel pin which is so often used in the construction of other competitive hoist rings. This unique design element enables disassembly of our hoist rings for inspection, compliance testing and reassembly.

General maintenance and care

Improper maintenance and inspection of your hoist ring could result in damaged equipment, personal injury or even death. In order to ensure maximum safety please read, understand and follow these maintenance and inspection guidelines prior to using any lifting hoist ring.

- When not in use, store hoist rings carefully to prevent corrosion or accidental damage.
- Do not remove the installation and safety tag from the lifting device. Ensure the identification tag remains legible during the life to the lifting device.

Maintenance

Visually inspect the lifting device prior to any use. Frequency of inspection should increase with the frequency of use, severity of service conditions and the more safety critical the use of the device. Discontinue use of any lifting device if inspection identifies any of the following:

- Missing identification tags.
- Indications of heat damage.
- Excessive corrosion or pitting.
- Damaged or missing load bearing components.
- Excessive nicks or gouges.
- Excessive thread damage.
- Evidence of unauthorised welding or modification.
- Lack of ability to swivel 360° or pivot 180°.

Inspection

Important installation and operation instructions

Installation

- Ensure thread has been tapped perpendicular to the mounting surface. Mounting surface should be flat to provide full 360° flush seating for the hoist ring.
- For installation in ferrous metal ensure bolt is tightened to the full torque load +0-20% (as specified on the product data sheet).
- To ensure the 5:1 design safety factor we recommend the ultimate tensile strength of the mating material to be min. 80,000 psi.
- For weaker mating material consider using longer bolts or through hole mounting with a nut and washer on the back side. To prevent stripping the mating thread, lower torque values (down to half the stated value) may be considered in temporary installations.
- On completion of installation check the lifting ring can swivel and pivot freely in all directions.
- Use at temperatures between -30°C and +200°C

Safety notes

- Never exceed the working load limit.
- Visually inspect the hoist ring for damage before each use.
- Loosening of the a bolt may develop after prolonged service, it is advisable to periodically retighten to the specified torque value.
- Apply lifting loads gradually to avoid shock loads.
- Use of free fit spacers between the lifting ring bush flange and the mounting surface is not recommended.
- Do not over size hooks nor use attachment methods which spread the ring.
- It is important to align the lifting ring with ~the direction of the load.
- Do not attach guidelines to hoist rings.
- Do not leave a gap between lifting ring bushing and mounting surface.
- Never allow personnel to walk underneath a suspended load.

It is very important for you to read and comply with these installation and safety notes prior to use or any lifting device.

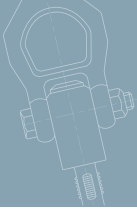

Formula to calculate the load per lifting ring

$$F = \frac{W}{N \sin A}$$

F = force on each hoist ring
 N = number of hoist rings
 A = lifting angle
 W = total weight

For example:

If A = 65° $F = \frac{4000}{4 \sin 65^\circ} = 1103 \text{ lbs.}$

If A = 14° $F = \frac{4000}{4 \sin 14^\circ} = 4134 \text{ lbs.}$

Important note: The force exerted on each hoist ring is not simply a function of the total weight divided by the number of hoist rings, but is critically reliant upon the lifting angle, greater forces are present the lower the lifting angle. See example below.

Angular lifting

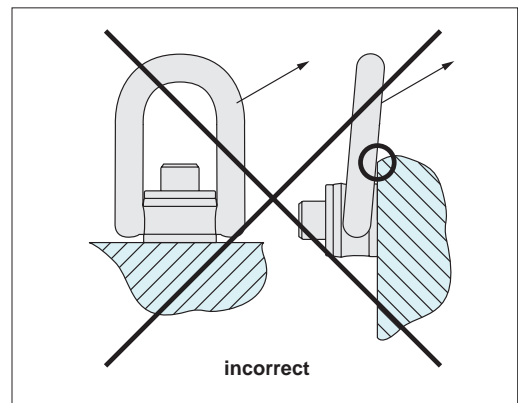
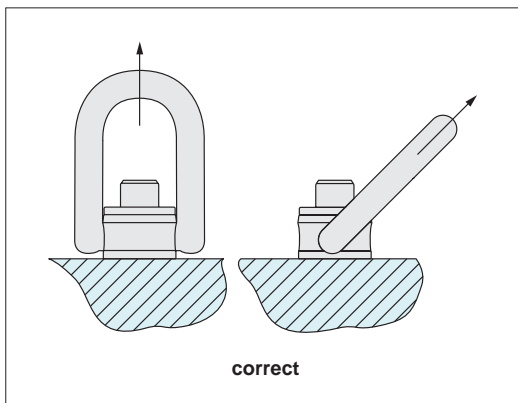
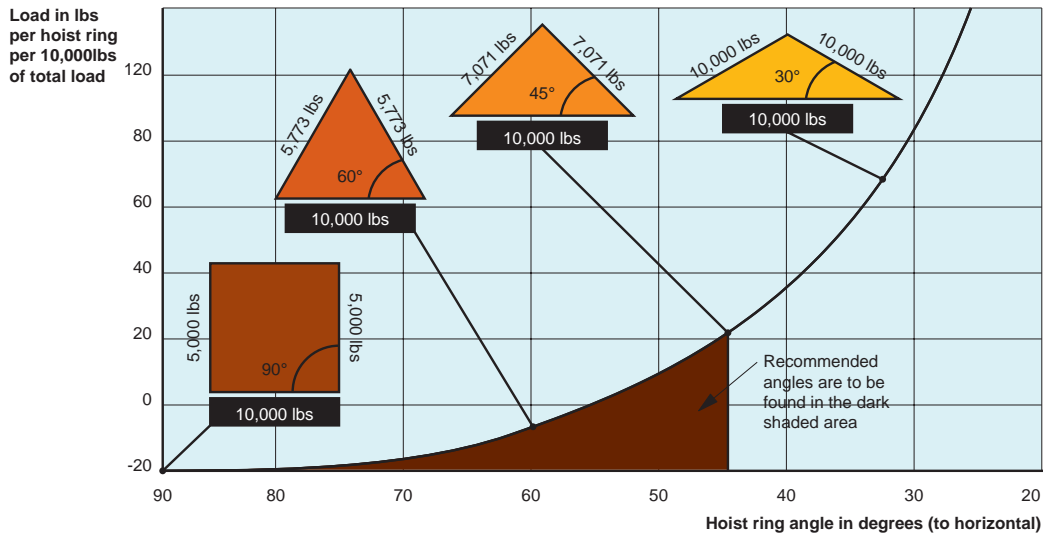

Do not allow the lifting ring to bind/stick and hence apply side loads to the bail. Ensure loads applied are in the same direction of the bail. If necessary use a spreader bar to avoid binding.

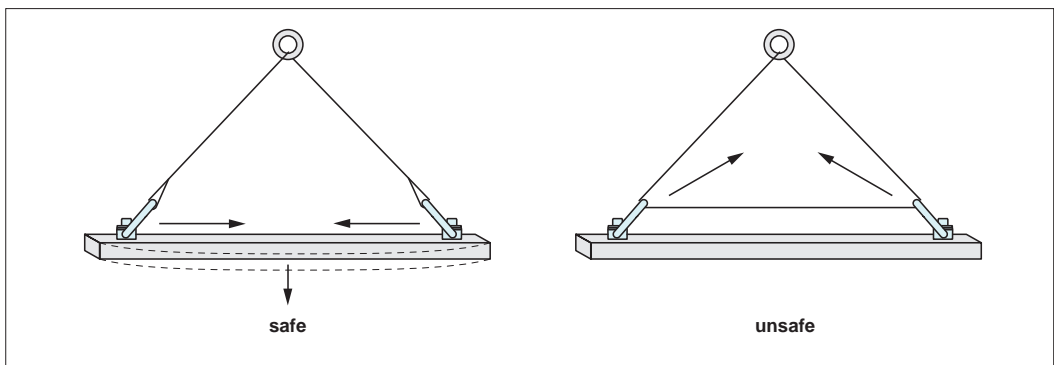

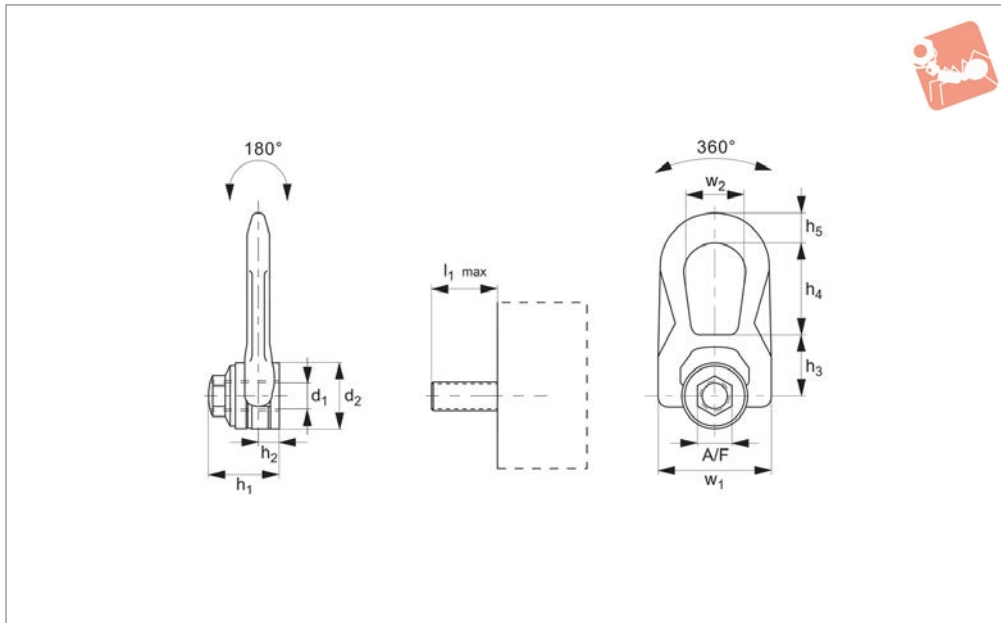

63054

LIFTING POINTS & SHACKLES

Material

High tensile steel, strength class >8.
Supplied with CE certificate.

Technical Notes

Double articulation.
Very low overhang for improved safety.
Large support surface.
For use in temperatures from -20°C to +200°C. Can be used in lower or higher temperatures,

but this affects the load rating - please ask for more information.

Please refer to our technical information pages when specifying and/or using.

Tips

Double articulation allows perfect alignment with the sling if the part rotates during the lift.

With „automatic“ position recovery system for best orientation to sling direction.

Tighten by hex. key or spanner.

Important Notes

Please read our instruction leaflet when specifying and/or using.

Please refer to the safety documentation before using this part.

Supplied with certificate and operating instructions.

Order No.	Load tons (t) max.	d ₁ 6H (tol. 2A)	h ₁ & l _{max}	h ₂	h ₃	h ₄	h ₅	w ₁	d ₂	w ₂	A/F	Safety factor	Torque to Nm	Weight kg
63054.W0008	0.5	M 8x 1,25	45	13	40	53	17	76	45	38	20	4	6	0.9
63054.W0010	0.9	M10x1,50	45	13	40	53	17	76	45	38	20	4	10	0.9
63054.W0012	1.3	M12x1,75	45	13	40	53	17	76	45	38	20	4	15	0.9
63054.W0016	2.3	M16x2,00	45	13	40	53	17	76	45	38	20	4	50	0.9
63054.W0020	2.5	M20x2,50	62	19	55	83	25	115	60	55	24	4	100	2.6
63054.W0038	(1.600)	(UNC 3/8"-16)	45	13	40	53	17	76	45	38	20	4	8	0.9
63054.W0058	(4.900)	(UNC 5/8"-11)	45	13	40	53	17	76	45	38	20	4	40	0.9
63054.W0088	(9.800)	(UNC 7/8"-9)	62	19	55	83	25	115	60	55	24	4	90	2.6



63084

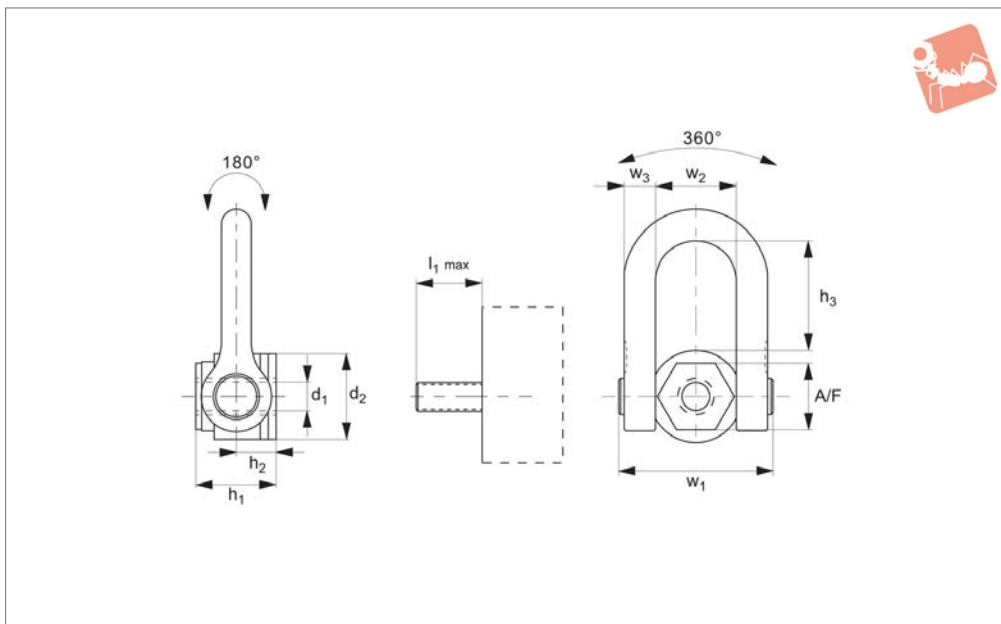

Material

High tensile steel, strength class >8.
Supplied with CE certificate.

Technical Notes

Designed to be used directly with the hook of the crane. Load ratings clearly marked. For use in temperatures from -20°C to +200°C. Can be used in lower or higher temperatures, but this affects the load rating - please ask

for more information.

Please refer to our technical information pages when specifying and/or using.

Tips

Double articulation allows perfect alignment with the sling if the part rotates during the lift. With „automatic“ position recovery system for best orientation to sling direction. Tighten by hex. key or spanner.

Important Notes

Tolerance of male thread to be 6H (metric) or UNC-2B (inch).

Please refer to the safety documentation before using this part.
Supplied with certificate and operating instructions.

Order No.	Load tons (t) max.	d ₁ (tol. 6g (tol. 2A))	h ₁ & l _{max.}	h ₂	h ₃	w ₁	d ₂	w ₂	w ₃	A/F	Safety factor	Torque to Nm	Weight kg
63084.W0030	8.5	M30x3,5	66	31	98	149	70	73	33	50	4	250	5.1

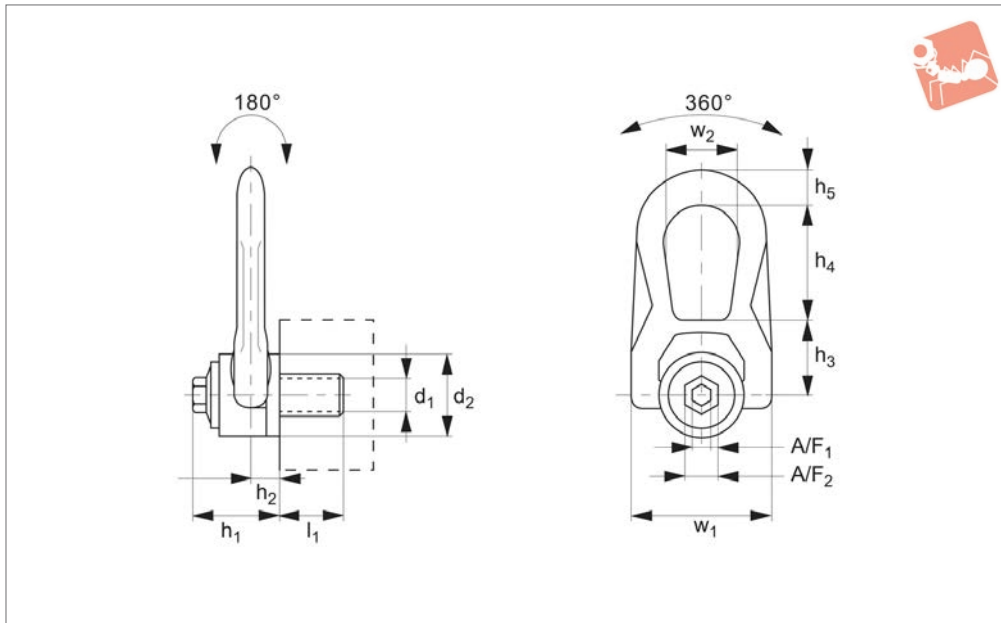

63200

LIFTING POINTS & SHACKLES

Material

High tensile stainless steel (316L), strength class >8.
Supplied with CE certificate.

Technical Notes

Double articulation.
Very low overhang for improved safety.
Large support surface.
For use in temperatures from -20°C to +200°C. Can be used in lower or higher temperatures but this affects the load rating - please ask for more information.
Longer or shorter thread lengths can be

supplied but please consult our technical department for this information if required.
Please refer to our technical information pages when specifying and/or using.

Tips

Double articulation allows perfect alignment with the sling.
With „automatic“ position recovery system for best orientation to sling direction.
Tighten by hex. key or spanner.

Important Notes

The thread diameter and depth must be appropriate to the material into which it will be installed:
Steel (min. ST37) - 1 x thread dia.
Cast iron - 1.25 x thread dia.
Aluminium - 2 x thread dia.
Other light metals - 2.5 x thread dia.
Tolerance of female thread to be 6H (metric) or UNC-2B (inch). **Please refer to the safety documentation before using this part.**
Supplied with certificate and operating

Order No.	Load tonnes (t) max.	d ₁ tol. 6g (tol. 2A)	h ₁	w ₁	h ₂	h ₃	h ₄	h ₅	d ₂	l ₁	w ₂	A/F ₁	A/F ₂	Safety factor	Torque to Nm	Weight kg
63200.W0008	0.3	M 8x 1,25	32	53	9.5	30	39	13	30	16	28	8	16	4	6	0.3
63200.W0010	0.5	M10x1,50	32	53	9.5	30	39	13	30	16	28	8	16	4	10	0.3
63200.W0012	0.8	M12x1,75	32	53	9.5	30	39	13	30	19	28	8	16	4	15	0.3
63200.W0014	1.0	M14x2,00	44	76	13.0	40	53	17	45	29	38	8	20	4	30	0.9
63200.W0016	1.5	M16x2,00	44	76	13.0	40	53	17	45	26	38	8	20	4	50	0.9
63200.W0018	1.5	M18x2,50	44	76	13.0	40	53	17	45	30	38	8	20	4	70	1.0
63200.W0020	1.6	M20x2,50	44	76	13.0	40	53	17	45	30	38	8	20	4	100	1.0
63200.W0022	2.2	M22x2,50	62	115	19.0	55	83	25	58	42	56	14	24	4	120	2.5
63200.W0024	2.7	M24x3,00	62	115	19.0	55	83	25	58	42	56	14	24	4	160	2.6
63200.W0027	2.9	M27x3,00	62	115	19.0	55	83	25	58	42	56	14	24	4	200	2.7
63200.W0030	3.5	M30x3,50	62	115	19.0	55	83	25	58	47	56	14	24	4	250	2.8



63200 Male

Lifting configuration	1		2		α max. = 60°		α max. = 60°		
	1	2	1	2	2	2	4	4	
No. of rings	1	2	1	2	2	2	4	4	
Lifting angle	0°	0°	90°	90°	45°	60°	45°	60°	
Thread	Maximum load rating for given lifting configuration								
M8	tons 0,30	0,60	0,30	0,60	0,40	0,30	0,60	0,30	
M8*	tons 0,30	0,60	0,30	0,60	0,40	0,30	0,60	0,30	
M10	tons 0,50	1,00	0,50	1,00	0,70	0,50	1,10	0,50	
M10*	tons 0,50	1,00	0,50	1,00	0,70	0,50	1,10	0,50	
M12	tons 0,80	1,60	0,80	1,60	1,10	0,80	1,70	0,80	
M12*	tons 0,80	1,60	0,80	1,60	1,10	0,80	1,70	0,80	
M14	tons 1,00	2,00	1,00	2,00	1,40	1,00	2,10	1,00	
M16	tons 1,50	3,00	1,50	3,00	2,10	1,50	3,20	1,50	
M18	tons 1,50	3,00	1,50	3,00	2,10	1,50	3,20	1,50	
M20	tons 1,60	3,20	1,60	3,20	2,20	1,60	3,40	1,60	
M22	tons 2,00	4,00	2,00	4,00	2,80	2,00	4,20	2,00	
M24	tons 2,70	5,40	2,70	5,40	3,80	2,70	5,70	2,70	
M27	tons 2,80	5,60	2,80	5,60	3,90	2,80	5,90	2,80	
M30	tons 3,00	6,00	3,00	6,00	4,20	3,00	6,30	3,00	

*Fine Thread.

Important Note: Table shows the maximum load rating for a given lifting configuration (NOT maximum load rating per individual lifting ring).

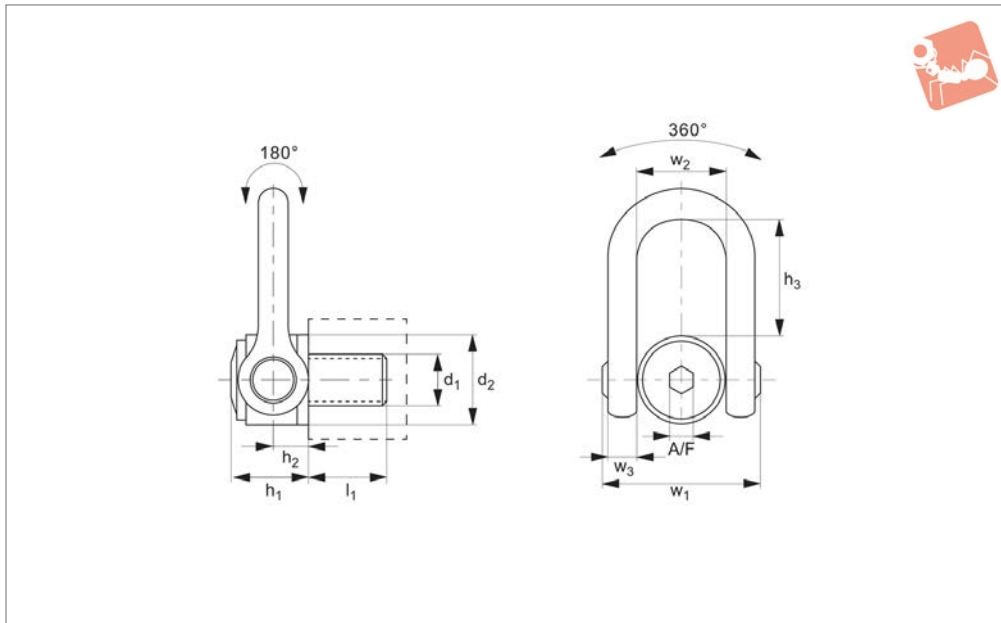

63210

LIFTING POINTS & SHACKLES

Material

High tensile stainless steel (316L), strength class >8.
Supplied with CE certificate.

Technical Notes

Double articulation, very low overhang for improved safety, large support surface. For use in temperatures from -20°C to +200°C. Can be used in lower or higher temperatures, but this affects the load rating - please ask for more information. *=non standard thread pitch. Longer or shorter thread lengths can be

supplied but please consult our technical department for this information if required. Please refer to our technical information pages when specifying and/or using.

Tips

Double articulation allows perfect alignment with the sling. With „automatic“ position recovery system for best orientation to sling direction. Tighten by hex. key or spanner.

Important Notes

The thread diameter and depth must be

appropriate to the material into which it will be installed:
Steel (min. ST37) - 1 x thread dia.
Cast iron - 1.25 x thread dia.
Aluminium - 2 x thread dia.
Other light metals - 2.5 x thread dia.
Tolerance of female thread to be 6H (metric) or UNC-2B (inch).
Please refer to the safety documentation before using this part.
Supplied with certificate and operating instructions.

Order No.	Load tons (t) max.	d ₁ tol. 6g (tol. 2A)	h ₁	w ₁	h ₂	h ₃	d ₂	l ₁	w ₂	w ₃	A/F	Safety factor	Torque to Nm (ft-lb)	Weight kg
63210.W0030	3.5	M30x3,5	61	149	31	98	70	45	73	30	19	4	250	5.2
63210.W0033	3.5	M33x3,5	61	149	31	98	70	50	73	30	19	4	250	5.2
63210.W0036	5.0	M36x4,0	61	149	31	98	70	54	73	30	19	4	320	5.2
63210.W0037	5.0	M36x3,0*	61	149	31	98	70	54	73	30	19	4	320	5.2
63210.W0039	5.0	M39x4,0	61	149	31	98	70	54	73	30	19	4	320	5.4
63210.W0042	6.0	M42x4,5	61	149	31	98	70	63	73	30	19	4	400	5.4
63210.W0043	6.0	M42x3,0*	61	149	31	98	70	63	73	30	19	4	400	5.4
63210.W0045	6.0	M45x4,5	61	149	31	98	70	63	73	30	19	4	400	5.7
63210.W0100	(6000)	(UNC 1"-8)	61	149	31	98	70	40	73	30	3/4"	4	(125)	5.2
63210.W0125	(7500)	(UNC 1 1/4"-7)	61	149	31	98	70	45	73	30	3/4"	4	(200)	5.2
63210.W0137	(7500)	(UNC 1 3/8"-6)	61	149	31	98	70	54	73	30	3/4"	4	(240)	5.2
63210.W0150	(11000)	(UNC 1 1/2"-6)	61	149	31	98	70	61	73	30	3/4"	4	(240)	5.4



63210 Male

Lifting configuration								
No. of rings	1	2	1	2	2	2	4	4
Lifting angle	0°	0°	90°	90°	45°	60°	45°	60°
Thread	Maximum load rating for given lifting configuration							
M24 tons	2,70	5,40	2,70	5,40	3,80	2,70	5,70	2,70
M27 tons	2,80	5,60	2,80	5,60	3,90	2,80	5,90	2,80
M30 tons	3,50	7,00	3,50	7,00	4,90	3,50	7,30	3,50
M33 tons	3,50	7,00	3,50	7,00	4,90	3,50	7,30	3,50
M36 tons	5,00	10,00	5,00	10,00	7,00	5,00	10,50	5,00
M36* tons	5,00	10,00	5,00	10,00	7,00	5,00	10,50	5,00
M39 tons	5,00	10,00	5,00	10,00	7,00	5,00	10,50	5,00
M42 tons	6,00	12,00	6,00	12,00	8,40	6,00	12,60	6,00
M42* tons	6,00	12,00	6,00	12,00	8,40	6,00	12,60	6,00
M45 tons	6,00	12,00	6,00	12,00	8,40	6,00	12,60	6,00
(UNC 1"-8) lbs	6,000	12,000	6,000	12,000	8,400	6,000	12,600	6,000
(UNC 1 1/4"-7) lbs	7,500	15,000	7,500	15,000	10,500	7,500	15,750	7,500
(UNC 1 3/8"-6) lbs	7,500	15,000	7,500	15,000	10,500	7,500	15,750	7,500
(UNC 1 1/2"-6) lbs	11,000	22,000	11,000	22,000	15,400	11,000	23,100	11,000

*Fine Thread

Important Note: Table shows the maximum load rating for a given lifting configuration (NOT maximum load rating per individual lifting ring).



Lifting Points - Double Swivel - Male

standard bar - metric - coarse - stainless steel

Lifting Points & Shackles

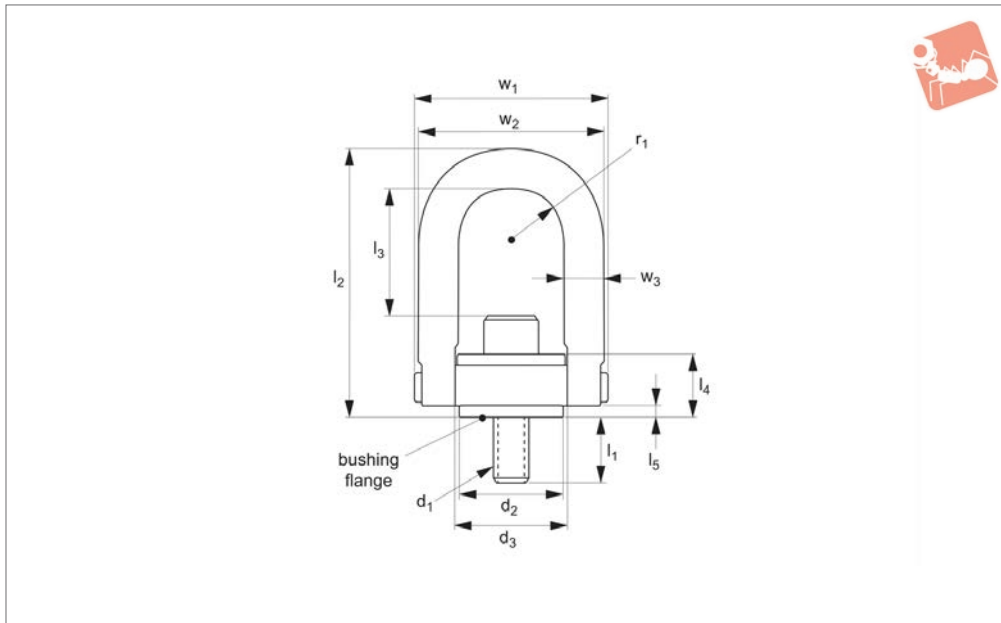

63571

LIFTING POINTS & SHACKLES

Material

Stainless steel, 300 series.

Each part individually numbered.

tl= recommended torque load (Nm.)

ASTM-A967.

Technical Notes

Min. design safety factor 5:1. 360° swivel and 180° pivot under load.

Tips

Liquid penetrant tested as ASTM-E1417.

Purification process, clean and passivate as

Important Notes

Always follow safety instructions.

Order No.	Rated load tonnes (t)	d ₁	l ₁	w ₁	d ₂	d ₃	l ₂	Weight kg
63571.W0081	0.200	M 8x1,25	17	46.7	19.1	25.4	67.8	0.14
63571.W0101	0.225	M10x1,50	17	46.7	19.1	25.4	67.8	0.14
63571.W0121	0.525	M12x1,75	19	89.4	38.0	50.5	121.4	1.05
63571.W0161	0.950	M16x2,00	24	89.4	38.0	50.5	121.4	1.11
63571.W0201	1.100	M20x2,50	30	89.4	38.0	50.5	121.4	1.16
63571.W0202	1.500	M20x2,50	29	130.5	58.7	76.2	165.8	3.06
63571.W0241	2.100	M24x3,00	34	130.5	58.7	76.2	165.8	3.18
63571.W0301	3.500	M30x3,50	46	165.1	81.3	95.5	221.7	3.36
63571.W0302	3.500	M30x3,50	66	165.1	81.3	95.5	221.7	6.70
63571.W0362	5.500	M36x4,00	69	217.2	106.7	123.7	316.7	15.34
63571.W0421	6.250	M42x4,50	79	217.2	106.7	123.7	316.7	15.91
63571.W0481	7.250	M48x5,00	79	217.2	106.7	123.7	316.7	16.36
63571.W0641	11.000	M64x6,00	102	269.4	146.1	165.6	428.5	39.77

Order No.	l ₃	l ₄	l ₅	r ₁	w ₂	w ₃	tl Nm
63571.W0081	32.1	18.0	4.3	10.9	40.9	9.5	4.75
63571.W0101	30.2	18.0	4.3	10.9	40.9	9.5	8.00
63571.W0121	59.4	31.0	4.1	24.4	82.5	19.0	18.50
63571.W0161	55.4	31.0	4.1	24.4	82.5	19.0	40.00
63571.W0201	51.4	31.0	4.1	24.4	82.5	19.0	67.50
63571.W0202	77.0	43.4	6.1	35.6	121.2	25.4	67.50
63571.W0241	73.0	43.4	6.1	35.6	121.2	25.4	155.50
63571.W0301	106.3	53.6	8.9	44.5	52.4	31.8	318.60
63571.W0302	106.3	53.6	8.9	44.5	52.4	31.8	318.60
63571.W0362	164.8	71.4	11.9	57.2	203.2	44.5	542.70
63571.W0421	158.8	71.4	11.9	57.2	203.2	44.5	542.70
63571.W0481	152.8	71.4	11.9	57.2	203.2	44.5	542.70
63571.W0641	203.3	104.0	28.4	76.2	266.7	57.2	1423.70



63572

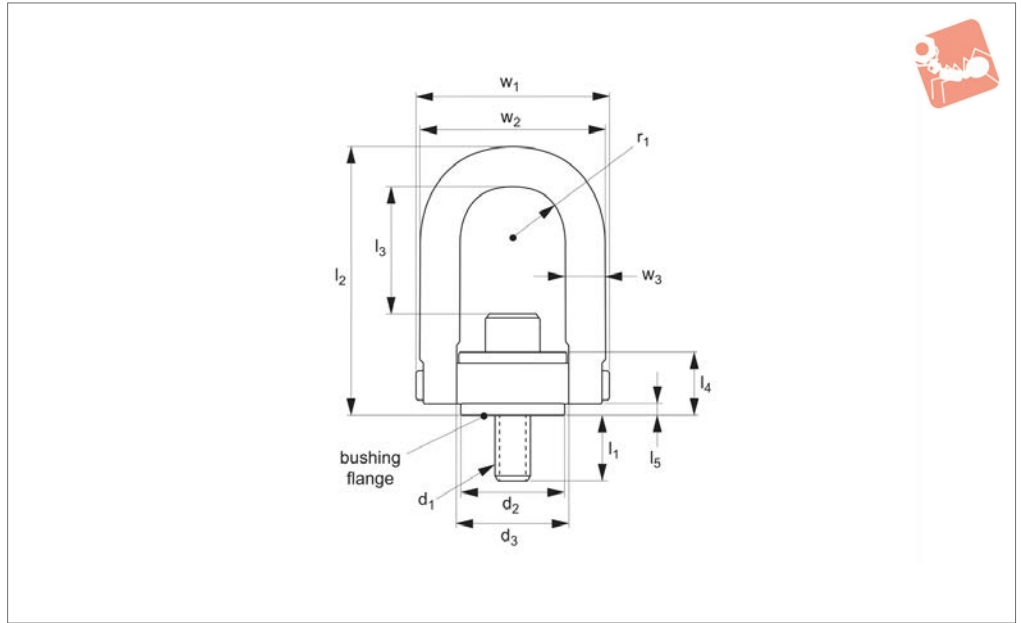

Material

Stainless steel, 300 series.

Technical Notes

Min. design safety factor 5:1. 360° swivel and 180° pivot under load.

Each part individually numbered.
tl = recommended torque load (Nm.)

Tips

Liquid penetrant tested as ASTM-E1417.
Purification process, clean and passivate as

ASTM-A967.

Important Notes

Always follow safety instructions.

Order No.	Rated load tonnes (t)	d ₁	l ₁	w ₁	d ₂	d ₃	l ₂	l ₃	l ₄	l ₅	r ₁	w ₂	tl Nm	Weight kg
63572.W0121	0.525	M12x1,75	19	89.4	38.0	50.5	121.4	108.6	31.0	4.1	22.4	82.5	18.5	1.27
63572.W0161	0.950	M16x2,00	24	89.4	38.0	50.5	121.4	104.6	31.0	4.1	22.4	82.5	40.0	1.33
63572.W0201	1.100	M20x2,50	30	89.4	38.0	50.5	121.4	100.6	31.0	4.1	22.4	82.5	67.5	1.38
63572.W0202	1.500	M20x2,50	29	130.5	58.7	76.2	165.8	117.9	43.4	5.1	35.6	121.2	67.5	3.77
63572.W0241	2.100	M24x3,00	34	130.5	58.7	76.2	165.8	113.9	43.4	6.1	35.6	121.2	155.5	3.89
63572.W0301	2.250	M30x3,50	54	130.5	58.7	76.2	165.8	109.0	43.4	6.1	35.6	121.2	155.5	4.01



Lifting Points - Double Swivel - Male

standard bar - UNC thread - stainless steel

Lifting Points & Shackles

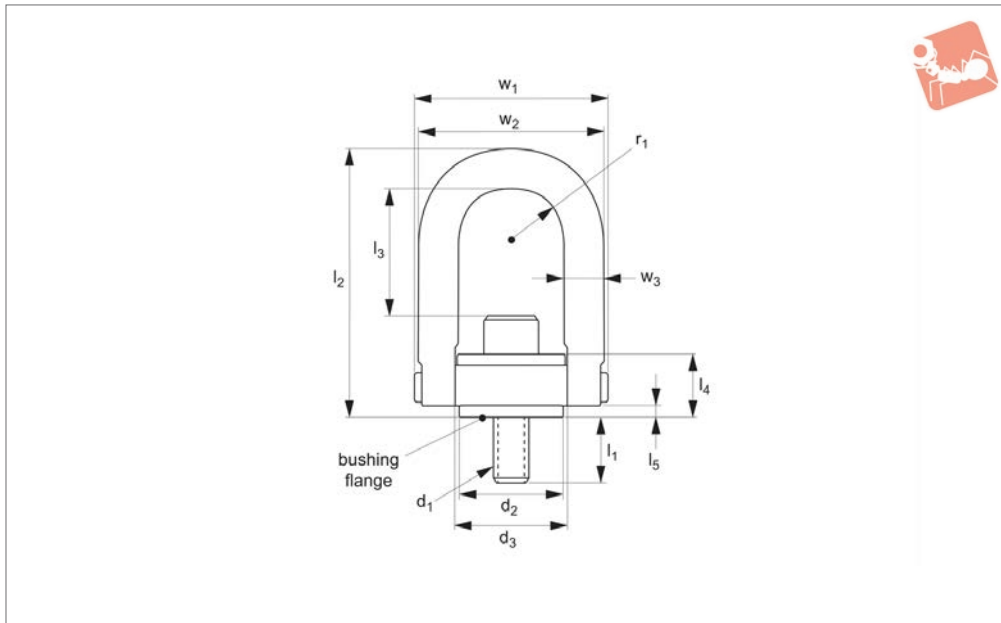

63581

LIFTING POINTS & SHACKLES

Material

Stainless steel, 300 series.

Each part individually numbered.

tl = recommended torque load (ft - lbs)

ASTM-A967.

Technical Notes

Min. design safety factor 5:1. 360° swivel and 180° pivot under load.

Tips

Liquid penetrant tested as ASTM-E1417. Purification process, clean and passivate as

Important Notes

All dimensions in imperial.

Always follow safety instructions.

Order No.	Rated load lb	d ₁	l ₁	w ₁	d ₂	d ₃	l ₂	l ₃	Weight lb
63581.W0251I	275	1/4-20	0.54	1.84	0.75	1.00	2.67	1.33	0.31
63581.W0311I	400	5/16-18	0.29	1.84	0.75	1.00	2.67	1.27	0.31
63581.W0312I	400	5/16-18	0.54	1.84	0.75	1.00	2.67	1.27	0.31
63581.W0371I	500	3/8-16	0.54	1.84	0.75	1.00	2.67	1.21	0.31
63581.W0501I	1250	1/2-13	1.07	2.58	1.25	1.49	3.77	1.84	1.00
63581.W0502I	1250	1/2-13	0.78	3.52	1.50	1.99	4.78	2.31	2.31
63581.W0503I	1250	1/2-13	1.03	3.52	1.50	1.99	4.78	2.31	2.31
63581.W0504I	1250	1/2-13	1.28	3.52	1.50	1.99	4.78	2.31	2.31
63581.W0631I	2000	5/8-11	0.78	3.52	1.50	1.99	4.78	2.18	2.43
63581.W0632I	2000	5/8-11	1.03	3.52	1.50	1.99	6.72	2.18	2.43
63581.W0634I	2000	5/8-11	1.28	3.52	1.50	1.99	6.72	2.18	2.43
63581.W0751I	2500	3/4-10	1.03	3.52	1.50	1.99	6.72	2.06	2.56
63581.W0752I	2500	3/4-10	1.53	3.52	1.50	1.99	6.72	2.06	2.56
63581.W0753I	3500	3/4-10	1.04	5.14	2.37	3.00	6.52	3.06	6.62
63581.W0754I	3500	3/4-10	1.54	5.14	2.37	3.00	6.52	3.06	6.62
63581.W0881I	4000	7/8-9	1.04	5.14	2.37	3.00	6.52	2.93	6.75
63581.W1001I	5000	1-8	1.29	5.14	2.37	3.00	6.52	2.81	7.00
63581.W1002I	5000	1-8	1.54	5.14	2.37	3.00	6.52	2.81	7.00
63581.W1003I	5000	1-8	2.29	5.14	2.37	3.00	6.52	2.81	7.00
63581.W1251I	7500	1-1/4-7	1.89	6.50	3.20	3.76	8.73	4.12	14.00
63581.W1501I	12000	1-1/2-6	2.70	8.55	4.20	4.87	12.47	6.41	33.75
63581.W2001I	15000	2-4-1/4	2.96	8.55	4.20	4.87	12.47	5.41	36.00
63581.W2501I	25000	2-1/2-8	4.00	11.67	5.75	6.52	16.87	8.03	87.50
63581.W2502I	25000	2-1/2-4	4.00	11.67	5.75	6.52	16.87	8.03	87.50
63581.W3001I	37500	3-4	5.20	14.15	7.25	8.10	19.50	8.48	166.00
63581.W3501I	50000	3-1/2-4	7.00	15.90	7.75	8.60	22.09	9.28	240.00

Order No.	l ₄	l ₅	r ₁	w ₂	w ₃	tl ft-lb
63581.W0251I	0.71	0.17	0.43	1.61	3/8	2.5
63581.W0311I	0.71	0.17	0.43	1.61	3/8	3.5
63581.W0312I	0.71	0.17	0.43	1.61	3/8	3.5



Order No.	l_4	l_5	r_1	w_2	w_3	t_l ft·lb
63581.W0371I	0.71	0.17	0.43	1.61	3/8	6.0
63581.W0501I	0.93	0.20	0.70	2.40	1/2	14.0
63581.W0502I	1.22	0.16	0.88	3.25	3/4	14.0
63581.W0503I	1.22	0.16	0.88	3.25	3/4	14.0
63581.W0504I	1.22	0.16	0.88	3.25	3/4	14.0
63581.W0631I	1.22	0.16	0.88	3.25	3/4	30.0
63581.W0632I	1.22	0.16	0.88	3.25	3/4	30.0
63581.W0634I	1.22	0.16	0.88	3.25	3/4	30.0
63581.W0751I	1.22	0.16	0.88	3.25	3/4	50.0
63581.W0752I	1.22	0.16	0.88	3.25	3/4	50.0
63581.W0753I	1.71	0.24	1.40	4.80	1	50.0
63581.W0754I	1.71	0.24	1.40	4.80	1	50.0
63581.W0881I	1.71	0.24	1.40	4.80	1	80.0
63581.W1001I	1.71	0.24	1.40	4.80	1	115.0
63581.W1002I	1.71	0.24	1.40	4.80	1	115.0
63581.W1003I	1.71	0.24	1.40	4.80	1	115.0
63581.W1251I	2.11	0.35	1.75	6.00	1-1/4	235.0
63581.W1501I	2.81	0.47	2.25	8.00	1-3/4	400.0
63581.W2001I	2.81	0.47	2.25	8.00	1-3/4	400.0
63581.W2501I	4.09	1.12	3.00	10.50	2-1/4	1050.0
63581.W2502I	4.09	1.12	3.00	10.50	2-1/4	1050.0
63581.W3001I	5.27	1.00	3.75	13.00	2-3/4	2150.0
63581.W3501I	6.06	1.09	4.00	14.50	3-1/4	3300.0



Lifting Points - Double Swivel - Male

long bar - UNC thread - stainless steel

Lifting Points & Shackles

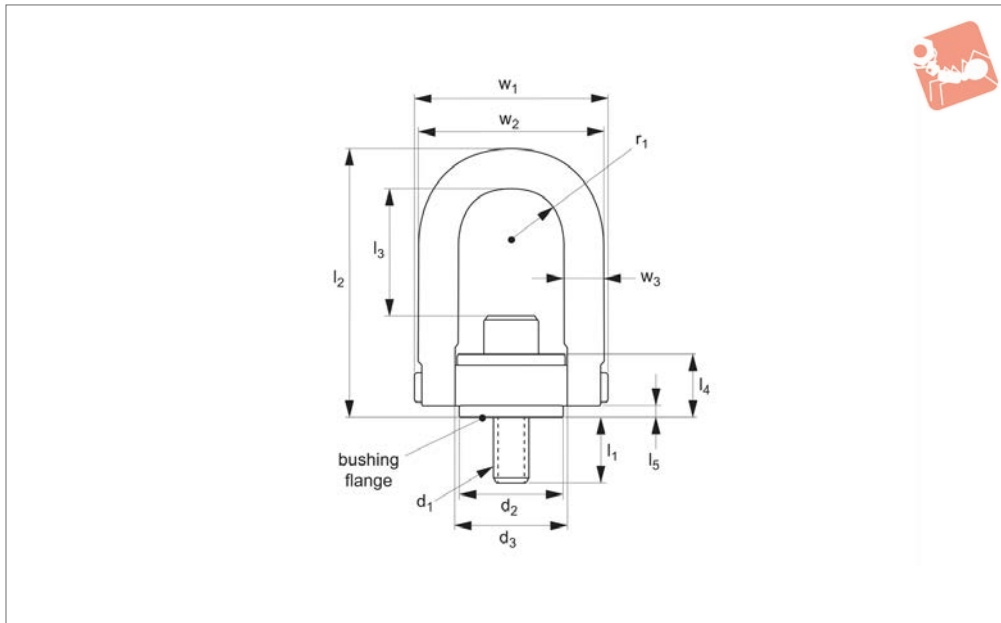

63582

LIFTING POINTS & SHACKLES

Material

Stainless steel, 300 series.

Each part individually numbered.

tl = recommended torque load (ft - lbs).

ASTM-A967.

Technical Notes

Min. design safety factor 5:1. 360° swivel and 180° pivot under load.

Tips

Liquid penetrant tested as ASTM-E1417.

Purification process, clean and passivate as

Important Notes

All dimensions in imperial.

Always follow safety instructions.

Order No.	Rated load lb	d ₁ UNC	l ₁	w ₁	d ₂	d ₃	l ₂	Weight lb
63582.W0501I	1250	1/2-13	0.78	3.52	1.50	1.99	6.72	2.75
63582.W0502I	1250	1/2-13	1.03	3.52	1.50	1.99	6.72	2.00
63582.W0503I	1250	1/2-13	1.28	3.52	1.50	1.99	6.72	2.75
63582.W0631I	2000	5/8-11	1.03	3.52	1.50	1.99	4.38	2.87
63582.W0632I	2000	5/8-11	1.28	3.52	1.50	1.99	4.38	2.75
63582.W0751I	2500	3/4-10	1.03	3.52	1.50	1.99	4.38	3.00
63582.W0752I	2500	3/4-10	1.53	3.52	2.37	1.99	4.38	3.00
63582.W0753I	3500	3/4-10	1.04	5.14	2.37	3.00	8.11	7.25
63582.W0754I	3500	3/4-10	1.54	5.14	2.37	3.00	8.11	6.62
63582.W0881I	4000	7/9-9	1.04	5.14	2.37	3.00	8.11	6.75
63582.W1001I	5000	1-8	1.29	5.14	2.37	3.00	8.11	7.00
63582.W1002I	5000	1-8	1.54	5.14	2.37	3.00	8.11	7.00
63582.W1003I	5000	1-8	2.29	5.14	2.37	3.00	8.11	7.00

Order No.	l ₃	l ₄	l ₅	r ₁	w ₂	w ₃	tl ft-lb
63582.W0501I	4.25	1.22	0.16	0.88	3.25	3/4	14
63582.W0502I	4.25	1.22	0.16	0.88	3.25	3/4	14
63582.W0503I	4.25	1.22	0.16	0.88	3.25	3/4	14
63582.W0631I	4.12	1.22	0.16	0.88	3.25	3/4	30
63582.W0632I	4.12	1.22	0.16	0.88	3.25	3/4	30
63582.W0751I	4.00	1.22	0.16	0.88	3.25	3/4	50
63582.W0752I	4.00	1.22	0.16	0.88	3.25	3/4	50
63582.W0753I	4.65	1.71	0.24	1.40	4.80	1	50
63582.W0754I	4.65	1.71	0.24	1.40	4.80	1	50
63582.W0881I	4.52	1.71	0.24	1.40	4.80	1	80
63582.W1001I	4.40	1.71	0.24	1.40	4.80	1	115
63582.W1002I	4.40	1.71	0.24	1.40	4.80	1	115
63582.W1003I	4.40	1.71	0.24	1.40	4.80	1	115



63204

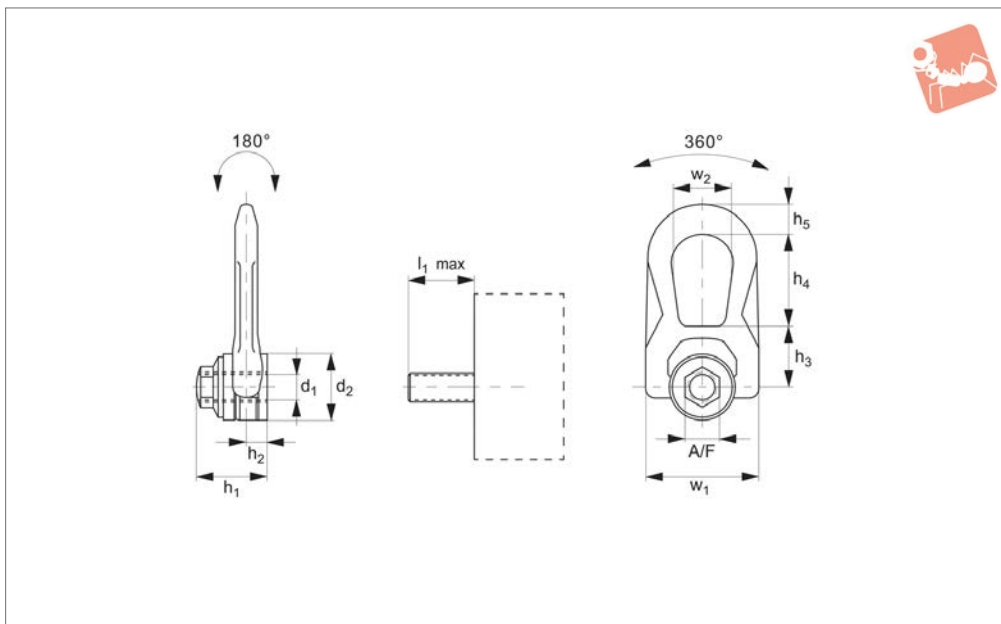

Material

High tensile stainless steel (316L), strength class >8.
Supplied with CE certificate.

Technical Notes

Double articulation, very low overhang for improved safety, large support surface.
For use in temperatures from -20°C to +200°C. Can be used in lower or higher temperatures, but this affects the load rating - please ask for more information.
Longer or shorter thread lengths can be

supplied but please consult our technical department for this information if required.
Please refer to our technical information pages when specifying and/or using.

Tips

Double articulation allows perfect alignment with the sling.
With „automatic“ position recovery system for best orientation to sling direction.
Tighten by hex. key or spanner.

Important Notes

The thread diameter and depth must be appropriate to the material into which it will be installed:

Steel (min. ST37) - 1 x thread dia.

Cast iron - 1.25 x thread dia.

Aluminium - 2 x thread dia.

Other light metals - 2.5 x thread dia.

Tolerance of male thread to be 6G (metric) or UNC-2B (inch).

Please refer to the safety documentation before using this part.

Supplied with certificate and operating

Order No.	Load tonnes (t) max.	d ₁ tol. 6g (tol. 2A)	h ₁ & l _{max.}	w ₁	h ₂	h ₃	h ₄	h ₅	d ₂	w ₂	A/F	Safety factor	Torque to Nm	Weight kg
63204.W0008	0.3	M 8x 1,25	43	76	13	40	53	17	45	38	20	4	6	0.9
63204.W0010	0.5	M10x1,50	43	76	13	40	53	17	45	38	20	4	10	0.9
63204.W0012	0.8	M12x1,75	43	76	13	40	53	17	45	38	20	4	15	0.9
63204.W0014	1.0	M14x2,00	43	76	13	40	53	17	45	38	20	4	30	0.9
63204.W0016	1.5	M16x2,00	43	76	13	40	53	17	45	38	20	4	50	0.9
63204.W0018	1.5	M18x2,50	62	115	19	55	83	25	58	56	24	4	70	2.6
63204.W0020	1.6	M20x2,50	62	115	19	55	83	25	58	56	24	4	100	2.6
63204.W0022	2.2	M22x2,50	62	115	19	55	83	25	58	56	24	4	120	2.6

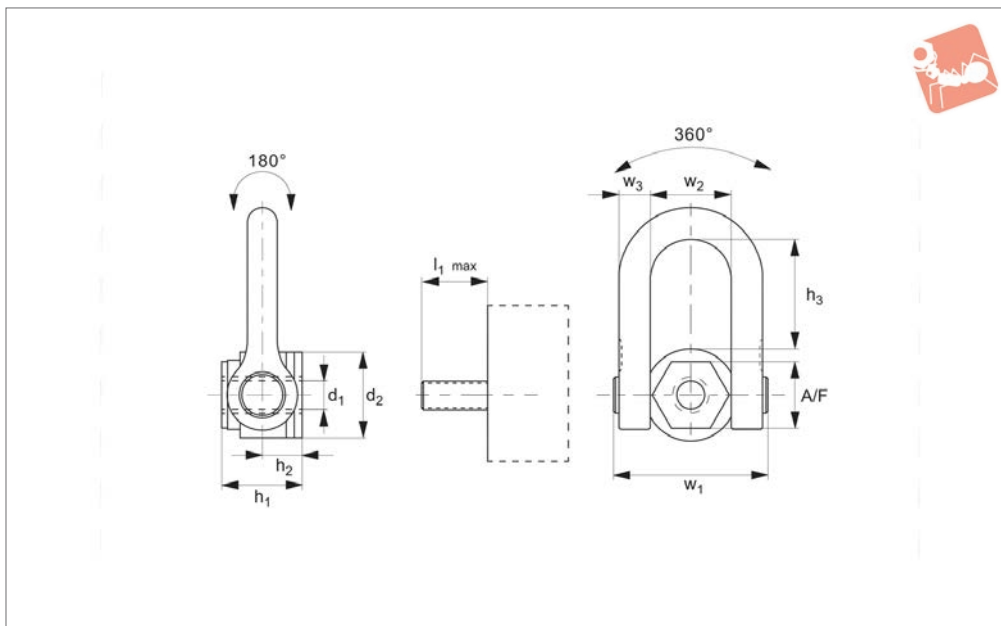

63214

LIFTING POINTS & SHACKLES

Material

High tensile stainless steel (316L), strength class >8.
Supplied with CE certificate.

Technical Notes

Double articulation, very low overhang for improved safety, large support surface. For use in temperatures from -20°C to +200°C. Can be used in lower or higher temperatures, but this affects the load rating - please ask for more information.

Please refer to our technical information pages when specifying and/or using.

Tips

Double articulation allows perfect alignment with the sling. With „automatic“ position recovery system for best orientation to sling direction. Tighten by hex. key or spanner.

Important Notes

The thread diameter and depth must be appropriate to the material into which it

will be installed:

- Steel (min. ST37) - 1 x thread dia.
- Cast iron - 1.25 x thread dia.
- Aluminium - 2 x thread dia.
- Other light metals - 2.5 x thread dia.
- Tolerance of male thread to be 6G (metric) or UNC-2B (inch).
- Please refer to the safety documentation before using this part.**
- Supplied with certificate and operating instructions.**

Order No.	Load tons (t) max.	d ₁ 6H (tol. 2A)	h ₁ & l ₁ max.	w ₁	h ₂	h ₃	d ₂	w ₂	w ₃	A/F	Safety factor	Torque to Nm	Weight kg
63214.W0024	2.7	M24x3,0	66	149	31	98	70	73	30	50	4	160	5.8
63214.W0030	3.5	M30x3,5	66	149	31	98	70	73	30	50	4	250	5.8
63214.W0033	3.5	M33x3,5	66	149	31	98	70	73	30	50	4	250	5.8
63214.W0036	5.0	M36x4,0	66	149	31	98	70	73	30	50	4	320	5.8
63214.W0125	(7.500)	(UNC 1 1/4"-7)	66	149	31	98	70	73	30	50	4	200	5.4



63001

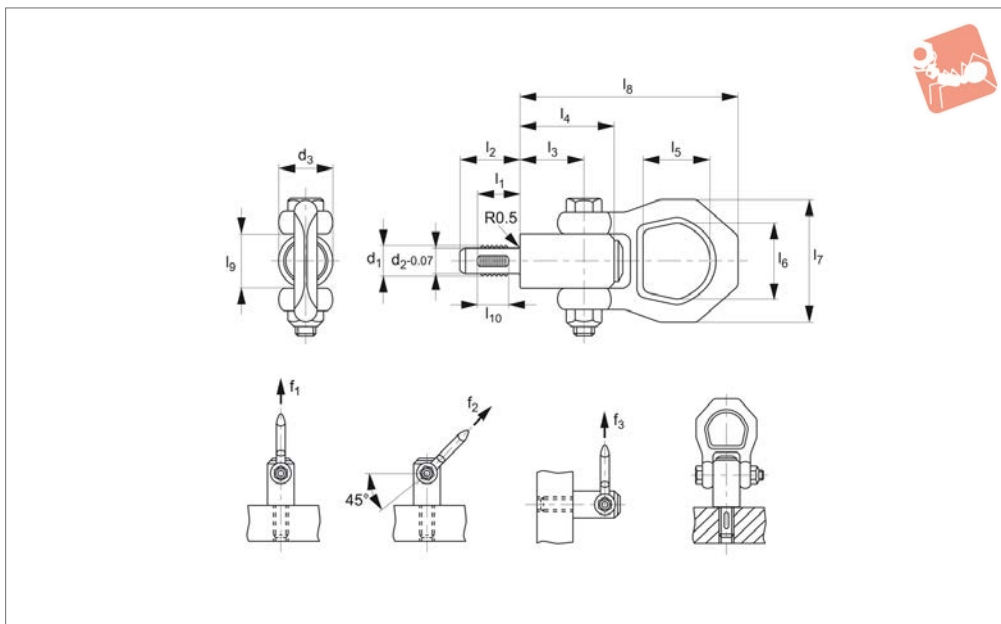

Material

Steel

Pin: Heat-treated steel, tempered, manganese phosphated.

Threaded element: Stainless steel 1.4542, (AISI 630) precipitation hardened.

Shackle: Steel, heat-treated, tempered, manganese phosphated.

Press button: Aluminium, orange anodised.

Spring: Stainless Steel.

Stainless steel

Pin: Stainless steel 1.4542, (AISI 630)

precipitation hardened.

Threaded element: Stainless steel 1.4542, (AISI 630) precipitation hardened.

Shackle: Stainless steel 1.45471.

Press button: Aluminium, orange anodised.

Spring: Stainless Steel.

Technical Notes

Both types are corrosion protected, stainless steel pin is resistant to corrosion and weathering, so suitable for external use.

Included: Instruction manual and CE Declaration of Conformity.

Depress button: unlock.

Release button: lock.

Tips

Before use: Read instruction manual, data sheets and follow standard safe lifting procedures.

Important Notes

f_1^* , f_2^* , and f_3^* values calculated on 5 x safety factor.

Order No.	Type	d_1	l_1	d_2 -0.07	d_3	l_2	l_3	l_4	l_5	Weight g
63001.W0010	Steel	M10	14	8.35	21.5	20	25.7	36	27	218
63001.W0012	Steel	M12	17	10.07	21.5	24	25.7	36	27	220
63001.W0016	Steel	M16	17	13.80	21.5	24	25.7	36	27	223
63001.W1010	Stainless	M10	14	8.35	21.5	20	25.7	36	27	218
63001.W1012	Stainless	M12	17	10.07	21.5	24	25.7	36	27	220
63001.W1016	Stainless	M16	17	13.80	21.5	24	25.7	36	27	223

Order No.	l_6	l_7	l_8	l_9	l_{10}	F_1 kN	F_2 kN	F_3 kN
63001.W0010	30	49	87.5	21.5	10	3.9	1.5	1.5
63001.W0012	30	49	87.5	21.5	12	6.2	2.5	2.3
63001.W0016	30	49	87.5	21.5	12	8.4	4.5	4.2
63001.W1010	30	49	87.5	21.5	10	3.9	1.5	1.5
63001.W1012	30	49	87.5	21.5	12	6.2	2.5	2.3
63001.W1016	30	49	87.5	21.5	12	8.4	4.5	4.2

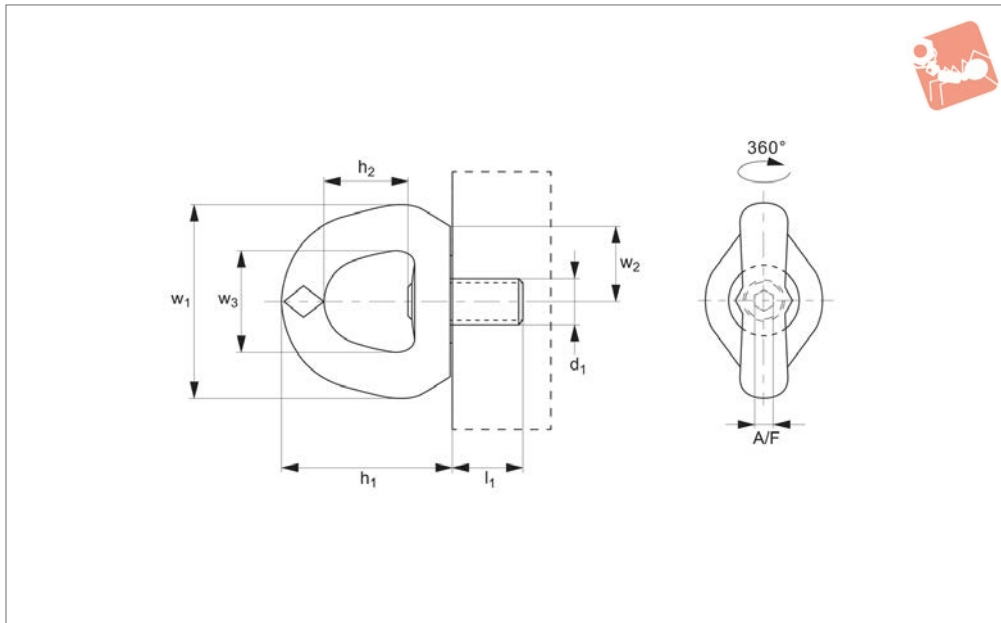

63020

LIFTING POINTS & SHACKLES

Material

High tensile steel, strength class >8.
Supplied with CE certificate.

Technical Notes

Single articulation, 360°, very low overhang for improved safety, large support surface.

Longer or shorter thread lengths can be supplied but please consult our technical department for this information if required.

For use in temperatures from -20°C to +200°C. Can be used in lower or higher

temperatures but, this affects the load rating - please ask for more information.
Please refer to our technical information pages when specifying and/or using.

Tips

Allows swivelling under load.
Swivel eye bolt with „automatic“ position recovery system for best orientation to sling direction.

Important Notes

The thread diameter and depth must be

appropriate to the material into which it will be installed:

Steel (min. ST37) - 1 x thread dia.

Cast iron - 1.25 x thread dia.

Aluminium - 2 x thread dia.

Other light metals - 2.5 x thread dia.

Tolerance of female thread to be 6H (metric).

Please refer to the safety documentation before using this part.

Supplied with certificate and operating instructions.

Order No.	Load tonnes (t) max.	d ₁ tol. 6G	l ₁	h ₁	h ₂	w ₁	w ₂	w ₃	A/F	Safety factor	Torque to Nm	Weight kg
63020.W0008	0.5	M 8x 1,25	14	57	30	60	20	34	6	4	6	0.24
63020.W0010	0.7	M10x1,50	17	57	30	60	20	34	6	4	10	0.24
63020.W0012	0.9	M12x1,75	21	57	30	60	20	34	6	4	15	0.24
63020.W0016	1.8	M16x2,00	27	80	38	88	35	45	8	4	50	0.80
63020.W0020	2.7	M20x2,50	30	80	38	88	35	45	8	4	100	0.80
63020.W0024	4.2	M24x3,00	36	106	58	115	50	70	14	4	160	2.60
63020.W0030	6.3	M30x3,50	45	106	58	115	50	70	14	4	250	2.70
63020.W0036	11.0	M36x4,00	54	155	83	168	70	94	14	4	320	7.00
63020.W0042	15.0	M42x4,50	63	155	83	168	70	94	14	4	400	7.00
63020.W0048	16.0	M48x5,00	68	155	80	168	70	94	19	4	600	7.00





Swivel Eye Bolts Male

male: stainless steel 316L

Lifting Points & Shackles

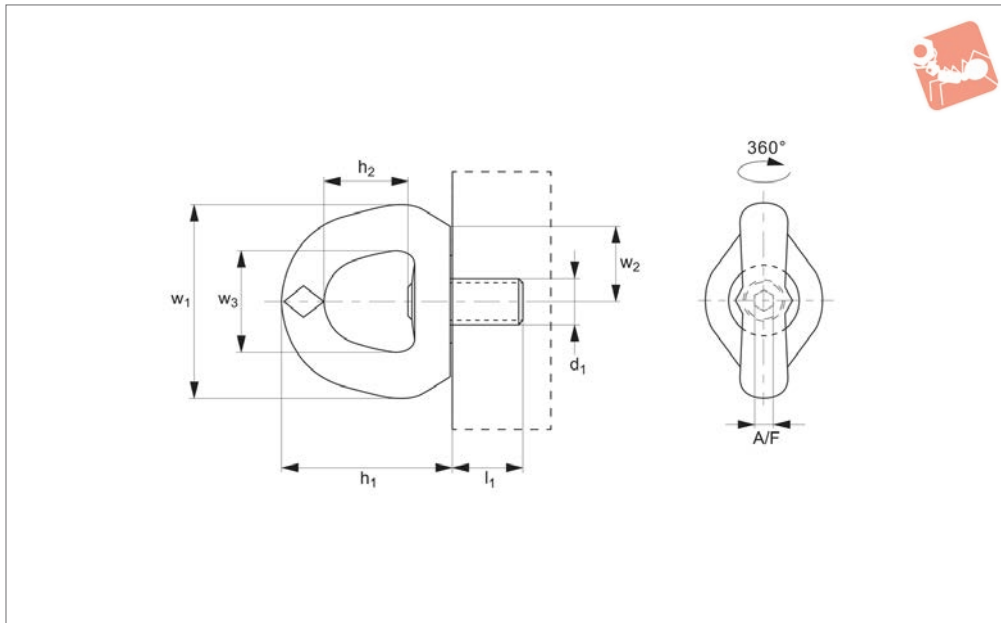

63022

LIFTING POINTS & SHACKLES

Material

Stainless steel 316L.
Supplied with CE certificate.

Technical Notes

Single articulation, 360°, very low overhang for improved safety, large support surface.
Longer or shorter thread lengths can be supplied but please consult our technical department for this information if required.
For use in temperatures from -20°C to +200°C. Can be used in lower or higher

temperatures but, this affects the load rating - please ask for more information.
Please refer to our technical information pages when specifying and/or using.

Tips

Allows swivelling under load.
Swivel eye bolt with „automatic“ position recovery system for best orientation to sling direction.

Important Notes

The thread diameter and depth must be

appropriate to the material into which it will be installed:
Steel (min. ST37) - 1 x thread dia.
Cast iron - 1.25 x thread dia.
Aluminium - 2 x thread dia.
Other light metals - 2.5 x thread dia.
Tolerance of female thread to be 6H (metric).
Please refer to the safety documentation before using this part.
Supplied with certificate and operating instructions.

Order No.	Load tonnes (t) max.	d ₁ tol. 6G	l ₁	h ₁	h ₂	w ₁	w ₂	w ₃	A/F	Safety factor	Torque to Nm	Weight kg
63022.W0012	0.55	M12x1,75	21	80	38	90	20	45	8	4	15	0.80
63022.W0016	1.20	M16x2,00	27	80	38	90	35	45	8	4	50	0.82

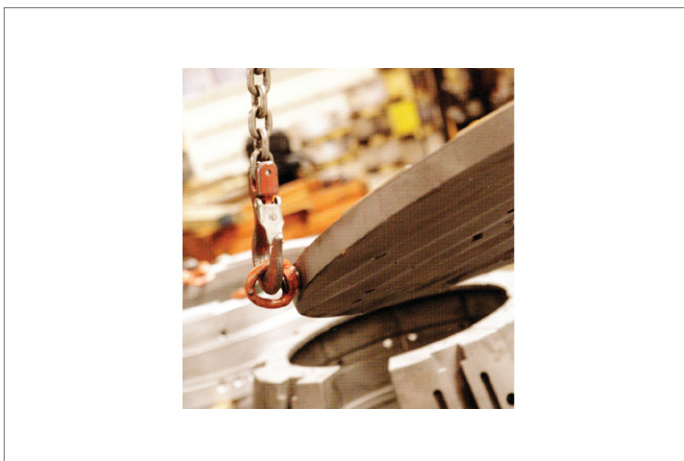



63024

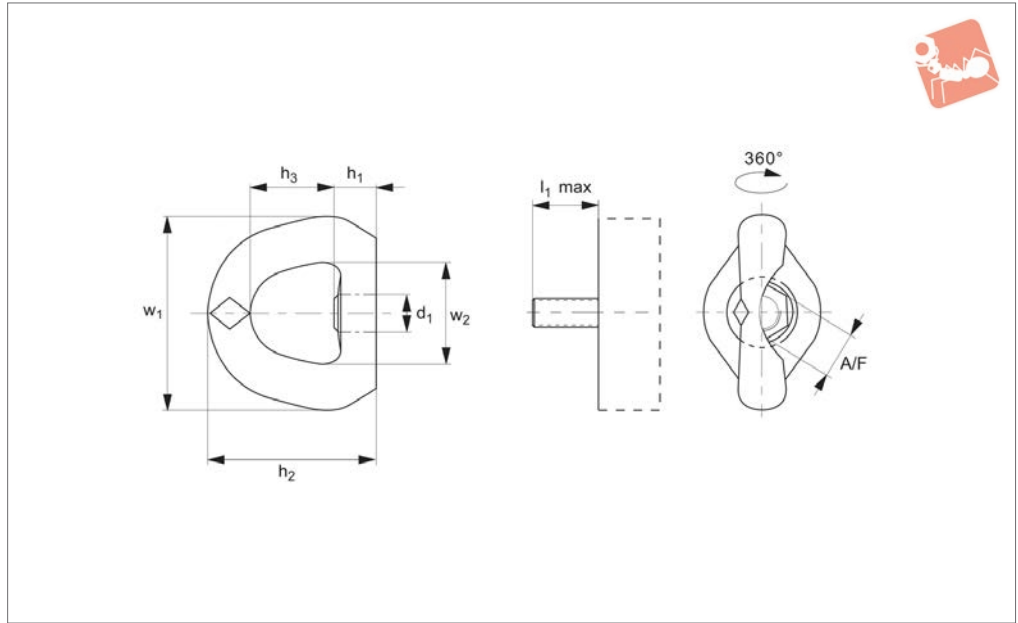

Material

High tensile steel, strength class >8.
Supplied with CE certificate.

Technical Notes

Single articulation, very low overhang for improved safety, large support surface.
For use in temperatures from -20°C to +200°C. Can be used in lower or higher temperatures, but this affects the load rating - please ask

for more information.

Please refer to our technical information pages when specifying and/or using.

Tips

Allows swivelling under load.
Swivel eye bolt with „automatic“ position recovery system for best orientation to sling direction.
Permits the hook to move parallel to the supporting face of the ring when being

pulled at 90° angle.

Important Notes

Tolerance of male thread to be 6g (metric).
Please refer to the safety documentation before using this part.
Supplied with certificate and operating instructions.

Order No.	Load tonnes (t) max.	d ₁ 6H	h ₁ & l _{max.}	h ₂	h ₃	w ₁	w ₂	A/F	Safety factor	Torque to Nm	Weight kg
63024.W0008	0.5	M 8x 1,25	22	80	38	88	45	21	4	6	0.8
63024.W0010	0.7	M10x1,50	22	80	38	88	45	21	4	10	0.8
63024.W0012	0.9	M12x1,75	22	80	38	88	45	21	4	15	0.8
63024.W0016	1.8	M16x2,00	22	80	38	88	45	21	4	50	0.8
63024.W0020	2.7	M20x2,50	35	106	55	115	70	36	4	100	2.5
63024.W0024	4.2	M24x3,00	48	155	77	168	94	40	4	160	6.3
63024.W0030	6.3	M30x3,50	48	155	77	168	94	40	4	250	6.3
63024.W0036	11.0	M36x4,00	48	155	77	168	94	40	4	320	6.3

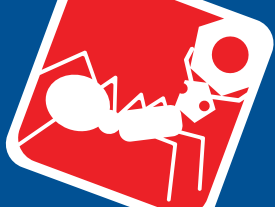

Swivel Eye Nuts Female

female

Lifting Points & Shackles



LIFTING POINTS & SHACKLES



63150

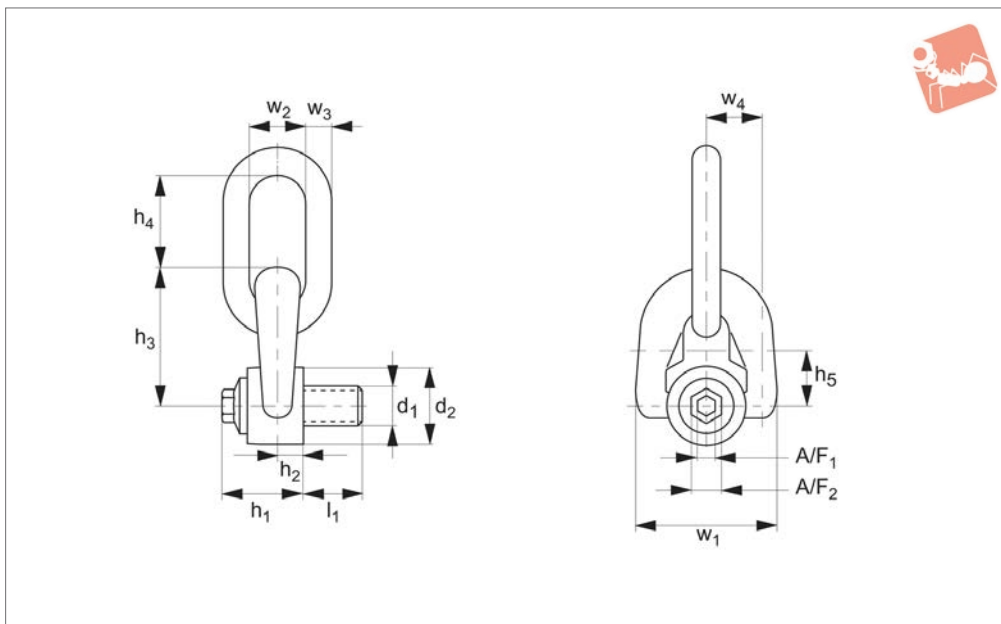

Material

High tensile steel, strength class >8.
Supplied with CE certificate.

Technical Notes

Three articulations.
Very low overhang for improved safety.
For use in temperatures from -20°C to +200°C. Can be used in lower or higher temperatures, but this affects the load rating - please ask for more information.
Longer or shorter thread lengths can be

supplied but please consult our technical department for this information if required.

Please refer to our technical information pages when specifying and/or using.

Tips

Tighten by hex. key or spanner.

Important Notes

The thread diameter and depth must be appropriate to the material into which it will be installed:

Steel (min. ST37) - 1 x thread dia.

Cast iron - 1.25 x thread dia.

Aluminium - 2 x thread dia.

Other light metals - 2.5 x thread dia.

Tolerance of female thread to be 6H (metric) or UNC-2B (inch).

Please refer to the safety documentation before using this part.

Supplied with certificate and operating instructions..

Order No.	Load tons (t) max.	d ₁ tol. 6g (tol. 2A)	l ₁	h ₁	w ₁	d ₂	h ₂	h ₃	h ₄	h ₅ & w ₄	w ₂	w ₃	A/F ₁	A/F ₂	Safety factor	Torque to Nm (ft-lb)	Weight kg
63150.W0008	0,40	M 8x 1,25	14	33	58	30	9,5	56	41	18	25	10	8	16	5	6	0,4
63150.W0010	0,70	M10x1,50	17	33	58	30	9,5	56	41	18	25	10	8	16	5	10	0,4
63150.W0012	1,05	M12x1,75	21	33	58	30	9,5	56	41	18	25	10	8	16	5	15	0,4
63150.W0014	1,40	M14x2,00	23	45	79	45	13,0	81	56	24	37	14	8	20	5	30	1,1
63150.W0016	2,00	M16x2,00	27	45	79	45	13,0	81	56	24	37	14	8	20	5	50	1,2
63150.W0018	2,30	M18x2,50	27	45	79	45	13,0	81	56	24	37	14	8	20	5	70	1,2
63150.W0020	2,50	M20x2,50	30	45	79	45	13,0	81	56	24	37	14	8	20	5	100	1,2
63150.W0022	3,00	M22x2,50	33	62	106	60	19,0	105	80	45	45	20	14	24	5	120	2,8
63150.W0024	4,00	M24x3,00	36	62	106	60	19,0	105	80	45	45	20	14	24	5	160	2,9
63150.W0027	5,00	M27x3,00	36	62	106	60	19,0	105	80	45	45	20	14	24	5	200	2,9
63150.W0030	6,30	M30x3,50	45	62	106	60	19,0	105	80	45	45	20	14	24	5	250	3,0
63150.W0036	10,00	M36x4,00	54	81	148	80	26,5	140	111	54	71	30	19	30	5	320	7,6
63150.W0042	12,50	M42x4,50	63	84	148	80	26,5	146	111	58	71	30	19	30	5	400	7,8
63150.W0048	20,00	M48x5,00	68	100	180	110	33,0	178	135	69	90	42	19	30	4	600	17,5
63150.W0056	22,00	M56x5,50	78	104	190	110	33,0	184	135	73	90	42	19	30	4	600	18,0
63150.W0231	(1,000)	(UNC 5/16"-18)	15	33	58	30	9,5	56	41	18	25	10	8	16	5	(7)	0,4
63150.W0250	(2,400)	(UNC 1/2"-13)	21	33	58	30	9,5	56	41	18	25	10	8	16	5	(12)	0,4
63150.W0275	(5,250)	(UNC 3/4"-10)	30	45	79	45	13,0	81	56	24	37	14	8	20	5	(80)	1,2
63150.W0300	(10,000)	(UNC 1"-8)	36	62	106	60	19,0	84	80	41	45	20	14	24	5	(125)	2,8
63150.W0350	(20,000)	(UNC 1 1/2"-6)	61	84	148	80	26,5	146	111	54	71	30	19	30	5	(240)	7,7



Triple Swivel Rings Male

Lifting Points & Shackles



LIFTING POINTS & SHACKLES



63651

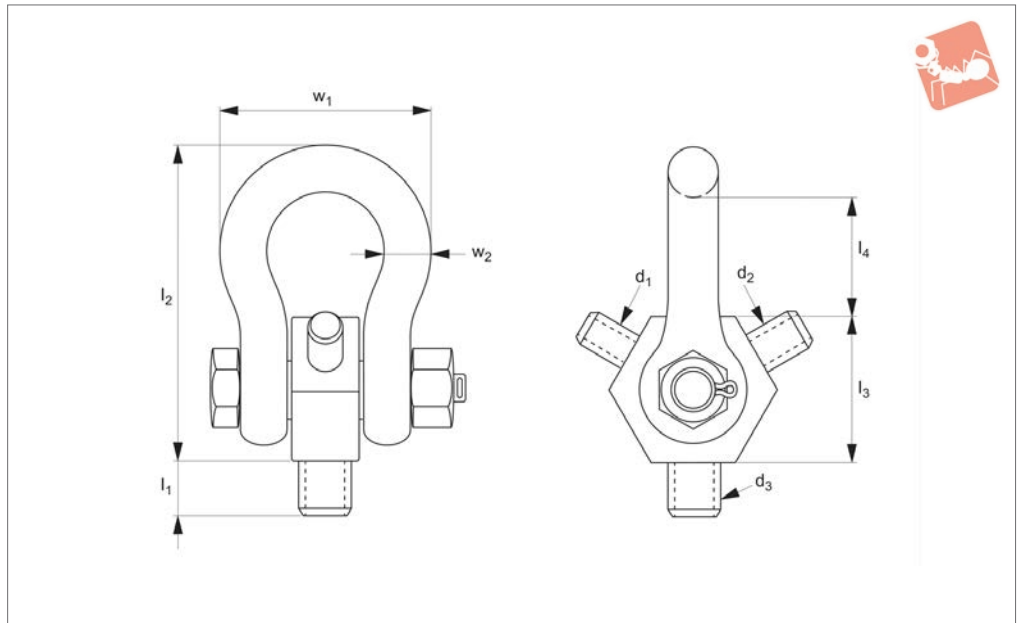

Material

Forged alloy steel.

Technical Notes

Flexible lifting ring with three threads in

one - vertical lifting only.

Always follow safety instructions.

Important Notes

For straight/vertical lifting only - do not apply side load.

Order No.	Thread	Thread size	Load capacity tonnes (t)	l ₁	l ₂	l ₃	l ₄	w ₁	w ₂	Weight kg
63651.W0812I	d1	M 8x1,25	0,40	13	77,80	34,93	31,8	53,98	11,11	0,36
	d2	M10x1,50	0,45	13	77,80	34,93	31,8	53,98	11,11	0,36
	d3	M12x1,75	1,05	13	77,80	34,93	31,8	53,98	11,11	0,36
63651.W1420I	d1	M14x2,00	1,05	19	111,13	50,80	44,5	76,20	15,90	1,13
	d2	M16x2,00	1,90	19	111,13	50,80	44,5	76,20	15,90	1,13
	d3	M20x2,50	2,20	19	111,13	50,80	44,5	76,20	15,90	1,13



Lifting Shackle - Tri-Thread - Male UNC thread

Lifting Points & Shackles

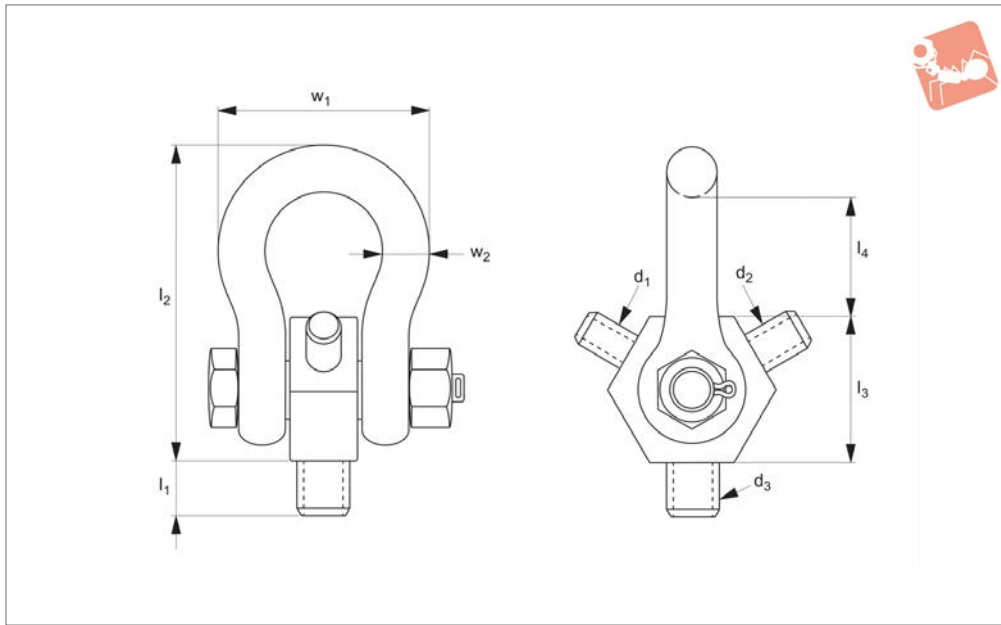

63652

LIFTING POINTS & SHACKLES

Material

Forged alloy steel.

one - vertical lifting only.

Always follow safety instructions.

Technical Notes

Flexible lifting ring with three threads in

Important Notes

For straight/vertical lifting only - do not apply side load.

Order No.	Thread	Type	Load capacity lb	Screw size UNC	l_1	l_2	l_3	l_4	w_1	w_2	Weight kg
63652.W2537I	d_1	Standard	400	1/4-20	1/2	3-1/16	1-3/8	1-1/4	2-1/8	7/16	0,8
	d_2	Standard	800	5/16-18	1/2	3-1/16	1-3/8	1-1/4	2-1/8	7/16	0,8
	d_3	Standard	1400	3/8-16	1/2	3-1/16	1-3/8	1-1/4	2-1/8	7/16	0,8
63652.W5075I	d_1	Standard	2600	1/2-13	3/4	4-3/8	2	1-3/4	3	5/8	2,5
	d_2	Standard	4000	5/8-11	3/4	4-3/8	2	1-3/4	3	5/8	2,5
	d_3	Standard	6000	3/4-10	3/4	4-3/8	2	1-3/4	3	5/8	2,5
63652.W2537F	d_1	Fine	400	1/4-28	1/2	3-1/16	1-3/8	1-1/4	2-1/8	7/16	0,8
	d_2	Fine	800	5/16-24	1/2	3-1/16	1-3/8	1-1/4	2-1/8	7/16	0,8
	d_3	Fine	1400	3/8-24	1/2	3-1/16	1-3/8	1-1/4	2-1/8	7/16	0,8
63652.W5075F	d_1	Fine	2600	1/2-20	3/4	4-3/8	2	1-3/4	3	5/8	2,5
	d_2	Fine	4000	5/8-18	3/4	4-3/8	2	1-3/4	3	5/8	2,5
	d_3	Fine	6000	3/4-16	3/4	4-3/8	2	1-3/4	3	5/8	2,5



63750

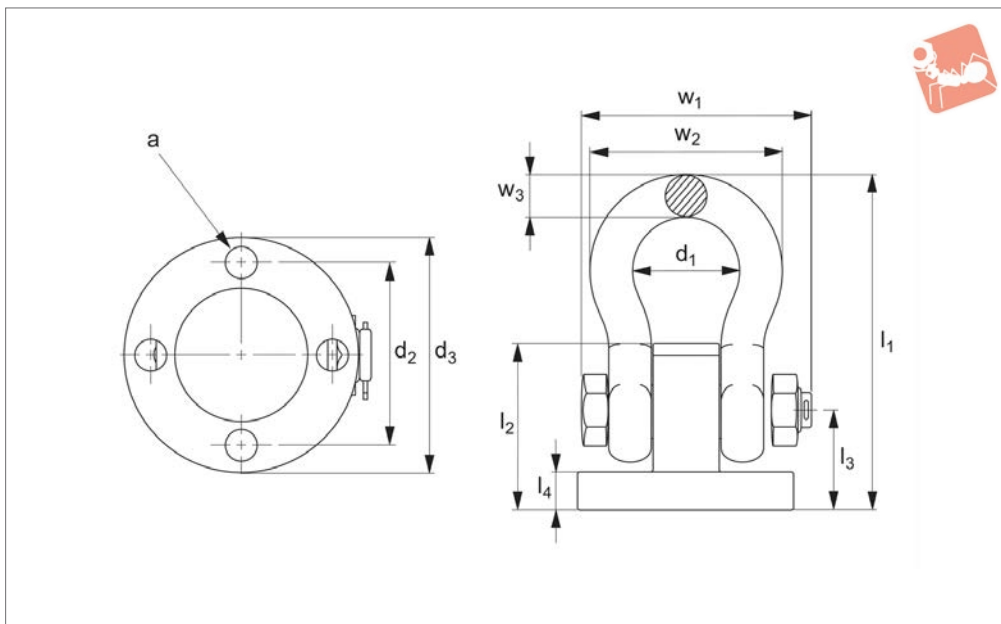

Material

Alloy steel, black oxide coated.

Technical Notes

Magnetic particle inspected as per ASTM 1444.

Tips

Min design factor 5:1. 360° swivel and 180° pivot under load. Particularly suited for lifting of large and heavy structures. Can be bolted or welded in place.

Important Notes

All dimensions in imperial.

Order No.	Working load lb	a for screw size	d ₁	d ₂	d ₃	l ₁	l ₂	l ₃	l ₄	w ₁	w ₂	w ₃
63750.W0251I	2000	1/4-20x1/2	1.03	1.56	2.1	2.96	1.43	0.91	0.40	2.17	1.78	0.38
63750.W0311I	3000	5/16-18x1/2	1.16	1.76	2.4	3.55	1.76	1.16	0.52	2.51	2.03	0.44
63750.W0371I	4000	3/8-16x5/8	1.31	2.10	2.9	3.91	1.91	1.21	0.52	2.80	2.31	0.50
63750.W0431I	6500	7/16-14x3/4	1.69	2.56	3.5	4.97	2.41	1.51	0.64	3.53	2.94	0.69
63750.W0631I	13000	5/8-11x1	2.28	3.40	4.6	6.85	3.31	2.06	0.90	4.71	4.03	0.97
63750.W0751I	19000	3/4-10x1 1/4	2.91	4.00	5.4	8.75	4.01	2.61	1.14	5.09	5.16	1.25
63750.W0881I	24000	7/8-9x2	3.25	4.50	6.1	9.68	4.51	2.91	1.30	6.51	5.75	1.38

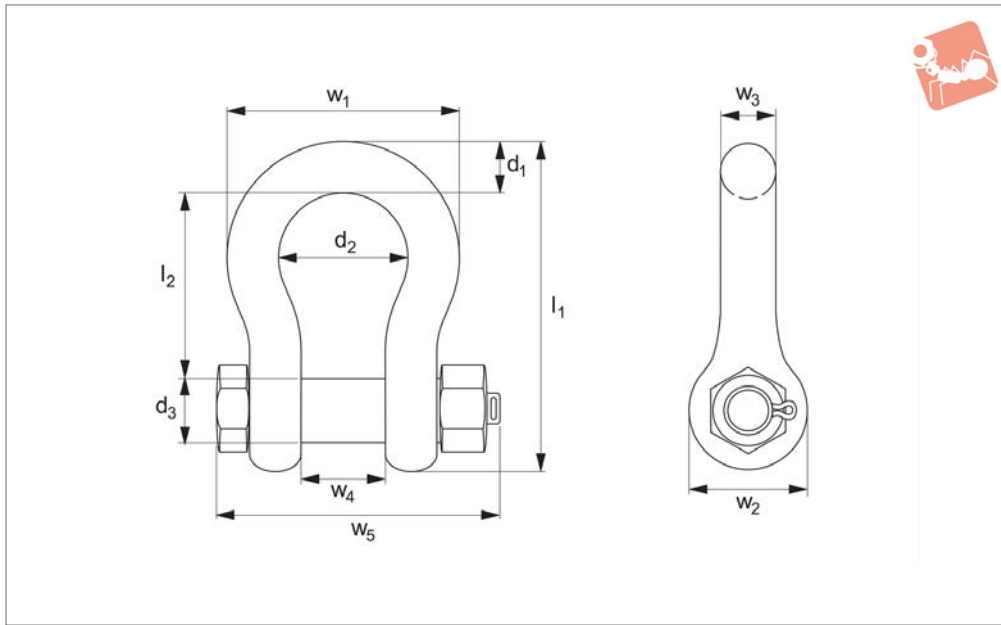

63752

Material

Forged alloy steel, black oxide coated.

Technical Notes

Supplied with thin head bolt, nut and

cotter pin.

Tips

Min. design safety factor 6:1.

Important Notes

All dimensions in imperial.

Order No.	Working load lb	d ₁	d ₂	d ₃	l ₁	l ₂	w ₁	w ₂	w ₃	w ₄	w ₅
63752.W0371I	2000	3/8	1.03	0.44	2.49	1.44	1.78	0.91	0.38	0.66	2.17
63752.W0431I	3000	7/16	1.16	0.50	2.91	1.69	2.03	1.06	0.44	0.75	2.51
63752.W0501I	4000	1/2	1.31	0.63	3.28	1.88	2.31	1.19	0.50	0.81	2.80
63752.W0631I	6500	5/8	1.69	0.75	4.19	2.38	2.94	1.50	0.63	1.06	3.53
63752.W0881I	13000	7/8	2.28	1.00	5.83	3.31	4.03	2.09	0.88	1.44	4.71
63752.W1141I	19000	1-1/8	2.91	1.25	7.47	4.25	5.16	2.69	1.13	1.81	6.00
63752.W1251I	24000	1-1/4	3.25	1.38	8.25	4.69	5.75	3.00	1.25	2.03	6.51



63621

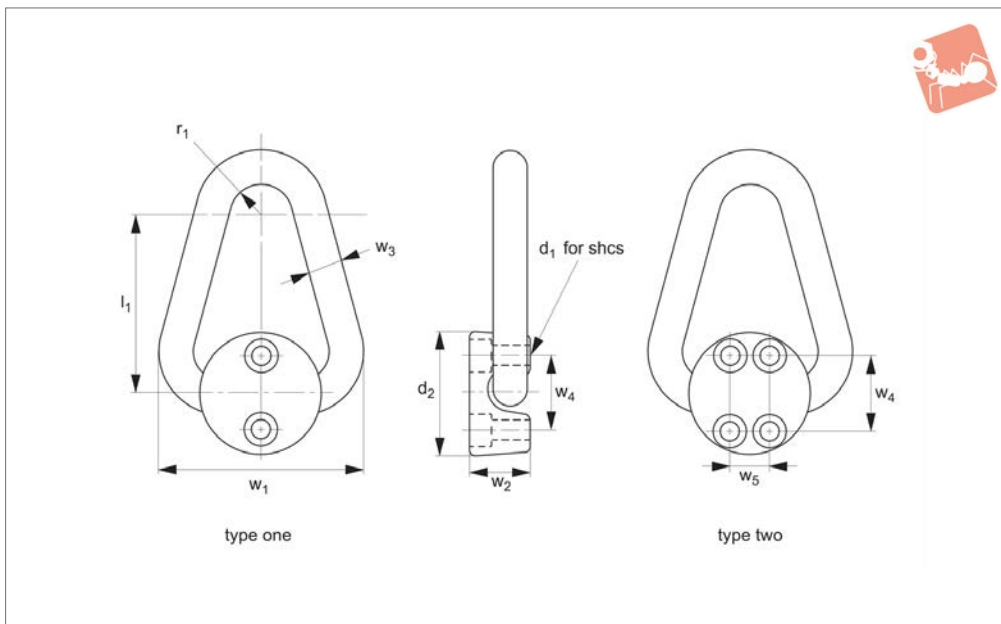

Material

Forged chrome moly steel, heat treated and black oxide coated.

Tips

Min. design safety factor 6:1. 180° pivot under load.

Always follow safety instructions.

Technical Notes

Magnaflux tested for ASTM 1444.

Important Notes

All dimensions in imperial.

Order No.	Type	Rated load lb	d ₁	r ₁	l ₁	d ₂	w ₁	Weight lb
63621.W0311I	One	2000	5/16 (x2)	1/2	2	1-3/4	2-1/2	0.58
63621.W0371I	One	2500	3/8 (x2)	5/8	2-1/2	2-1/4	3-3/16	1.07
63621.W0501I	One	5000	1/2 (x2)	3/4	3	2-5/8	3-7/8	2.06
63621.W0502I	Two	12000	1/2 (x4)	7/8	4	3-1/8	5-1/4	4.10
63621.W0631I	Two	20000	5/8 (x4)	1	5	3-5/8	6-3/16	7.94

Order No.	w ₂	w ₃	w ₄	w ₅	tl ft-lb	Screw thread	Screw length
63621.W0311I	3/4	5/16	1	0	4-7	5/16-18	1-1/4
63621.W0371I	7/8	3/8	1-1/8	0	7-10	3/8-16	1-1/4
63621.W0501I	1-1/8	1/2	1-1/2	0	20-25	1/2-13	2
63621.W0502I	1-3/8	3/4	1-5/8	1-1/4	20-25	1/2-13	2-1/4
63621.W0631I	1-7/8	1	2-1/16	1-1/4	42-50	5/8-11	2-3/4



Thread Adapter for male lifting points

Lifting Points & Shackles

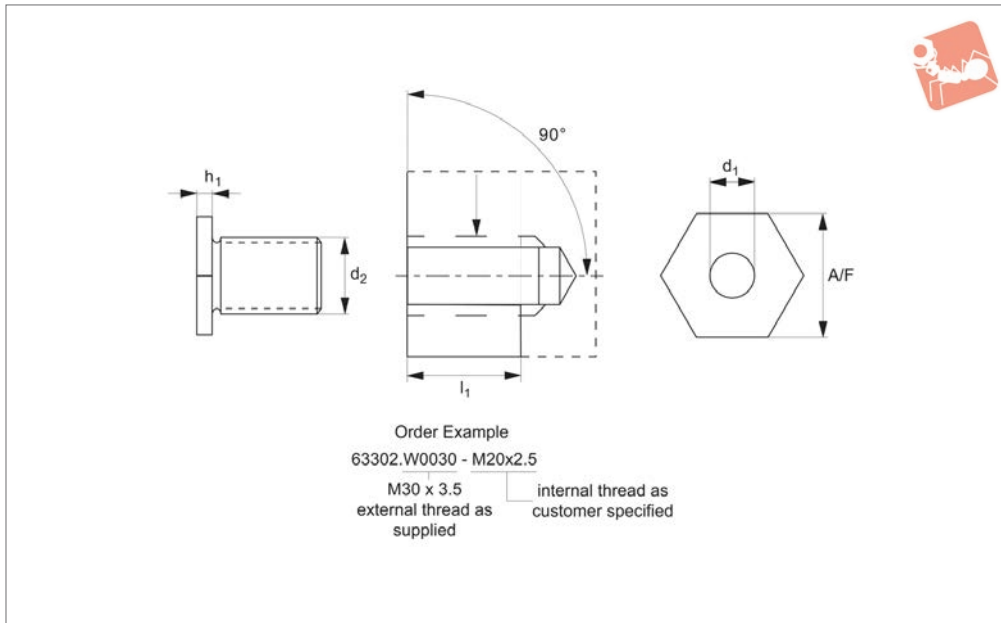

63302

LIFTING POINTS & SHACKLES

Material

High tensile steel, strength class >8.

Technical Notes

The internal portion of the adaptor can be machined (by us) to suit the required lifting bolt thread. Allowing differing sized

lifting bolts to be used.

XX - Advise the internal thread size and pitch required e.g.

63020.W0030 - M20x2,5.

Female thread tolerances required to be 6H (metric) or UNC-2B (inch).

Tips

Not suitable/rated for customers to machine internal threads themselves.

Only to be used with lifting bolts 63020 to 63150.

Order No.	d ₂ tol. 6g (tol. 2A)	d ₁ mm max.	d ₁ inch max.	l ₁	h ₁	A/F	Torque to Nm (ft-lb)
63302.W0024-xx	M24 x 3,0	18	5/8"	36	10	50	160
63302.W0030-xx	M30 x 3,5	20	7/8"	45	10	50	250
63302.W0036-xx	M36 x 4,0	27	1"	54	10	65	320
63302.W0040-xx	M42 x 4,5	33	1" 1/4	63	10	75	400
63302.W0048-xx	M48 x 5,0	39	1" 1/2	68	10	75	600
63302.W0056-xx	M56 x 5,5	42	1" 3/4	78	10	95	600
63302.W0064-xx	M64 x 6,0	52	2"	90	10	95	600
63302.W0100-xx	M100 x 6,0	80	3" 1/2	100	15	155	600
63302.W5088-xx	UNC 7/8"-9	16	5/8"	33	10	50	(100)
63302.W5100-xx	UNC 1"-8	18	3/4"	36	10	50	(125)
63302.W5125-xx	UNC 1" 1/4-7	24	7/8"	45	10	50	(200)
63302.W5138-xx	UNC 1" 3/8-6	27	1"	54	10	65	(300)
63302.W5150-xx	UNC 1" 1/2-6	30	1" 1/8	61	10	75	(300)
63302.W5200-xx	UNC 2"-4 1/2	39	1" 1/2	76	10	95	(450)
63302.W5275-xx	UNC 2" 3/4-4	56	2" 1/4	105	10	155	(600)
63302.W5400-xx	UNC 4"-4	80	3" 1/4	150	15	155	(800)



63601

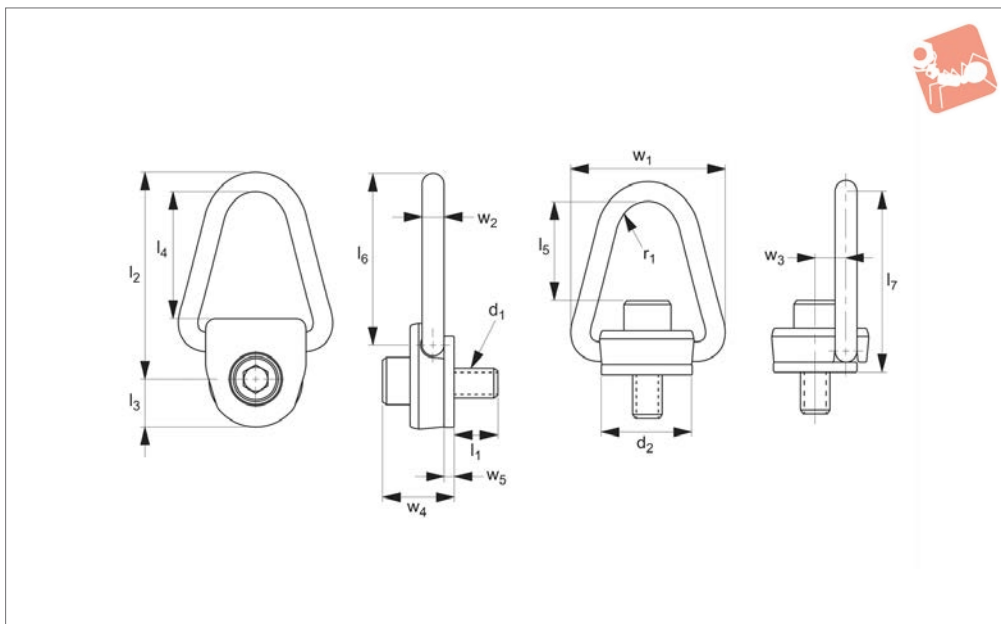

Material

Alloy steel, black oxide finish.

ASTM1444.

Rotates 360° under load.

Technical Notes

Magnetic particles inspected per

Important Notes

Min. design safety factor 5:1, any direction. Self aligning direction of load.

tl= recommended torque load (Nm).
Always follow safety instructions.

Order No.	Rated load tonnes (t)	d ₁	l ₁	d ₂	l ₂	l ₃	l ₄	l ₅	Weight kg
63601.W0081	0.40	M 8x1,25	14	56	130	32	81	73	0.93
63601.W0101	0.45	M10x1,50	24	56	130	32	81	71	0.96
63601.W0121	1.05	M12x1,75	37	56	130	32	81	69	0.96
63601.W0161	1.90	M16x2,00	37	56	130	32	81	65	1.01
63601.W0200	2.20	M20x2,50	37	56	130	32	81	61	1.07
63601.W0201	3.00	M20x2,50	39	79	171	41	106	83	2.73
63601.W0241	4.20	M24x3,00	43	79	171	41	106	79	2.78

Order No.	l ₆	l ₇	r ₁	w ₁	w ₂	w ₃	w ₄	w ₅	tl Nm
63601.W0081	108	120	19	99	13	22	34	5	9.5
63601.W0101	108	120	19	99	13	22	36	5	16.0
63601.W0121	108	120	19	99	13	22	38	5	37.0
63601.W0161	108	120	19	99	13	22	42	5	80.0
63601.W0200	108	120	19	99	13	22	46	5	135.0
63601.W0201	143	159	22	133	19	32	57	8	135.0
63601.W0241	143	159	22	133	19	32	61	8	311.0

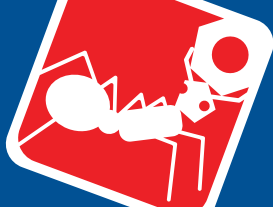

Load Rings - Side Pull - Male UNC thread

Load Rings & Eye Bolt

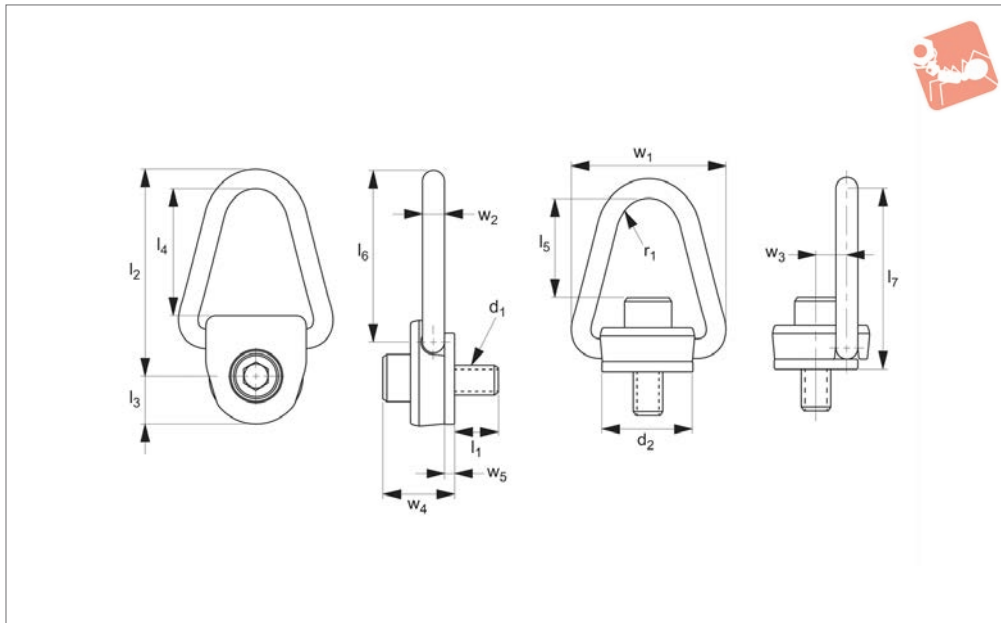

63602

LOAD RINGS & EYE BOLT

Material

Alloy steel, black oxide finish.

Technical Notes

Magnetic particles inspected per ASTM1444.

Tips

Min. design safety factor 5:1, any direction. Self aligning direction of load. Rotates 360° under load. tl= recommended torque load (ft - lbs).

Important Notes

All dimensions in imperial.
Always follow safety instructions.

Order No.	Rated load lb	d ₁ UNC	l ₁	d ₂	l ₂	l ₃	l ₄	l ₅	Weight lb
63602.W0311I	800	5/16-18	0.479	2-3/16	5-1/8	1-1/4	3-3/16	2-57/64	2.05
63602.W0371I	1000	3/8-16	0.479	2-3/16	5-1/8	1-1/4	3-3/16	2-27/32	2.12
63602.W0501I	2500	1/2-13	0.979	2-3/16	5-1/8	1-1/4	3-3/16	2-45/64	2.12
63602.W0631I	4000	5/8-11	0.979	2-3/16	5-1/8	1-1/4	3-3/16	2-59/64	2.22
63602.W0751I	5000	3/4-10	1.229	2-3/16	5-1/8	1-1/4	3-3/16	2-15/16	2.34
63602.W0752I	7000	3/4-10	1-1/4	2-3/16	6-3/4	1-5/8	4-3/16	4	6.01
63602.W0881I	8000	7/8-9	1-1/4	2-3/16	6-3/4	1-5/8	4-3/16	3-7/8	6.13
63602.W1001I	10000	1-8	1-1/2	2-3/16	6-3/4	1-5/8	4-3/16	3-3/4	6.20

Order No.	l ₆	l ₇	r ₁	w ₁	w ₂	w ₃	w ₄	w ₅	tl ft-lb
63602.W0311I	4-1/4	4-23/32	3/4	3-7/8	1/2	7/8	1-21/64	7/32	7
63602.W0371I	4-1/4	4-23/32	3/4	3-7/8	1/2	7/8	1-25/64	7/32	12
63602.W0501I	4-1/4	4-23/32	3/4	3-7/8	1/2	7/8	1-17/32	7/32	28
63602.W0631I	4-1/4	4-23/32	3/4	3-7/8	1/2	7/8	1-41/64	7/32	60
63602.W0751I	4-1/4	4-23/32	3/4	3-7/8	1/2	7/8	1-25/32	7/32	100
63602.W0752I	5-5/8	6-1/4	7/8	5-1/4	3/4	1-1/4	2-1/4	5/16	100
63602.W0881I	5-5/8	6-1/4	7/8	5-1/4	3/4	1-1/4	2-3/8	5/16	160
63602.W1001I	5-5/8	6-1/4	7/8	5-1/4	3/4	1-1/4	2-1/2	5/16	230



63700

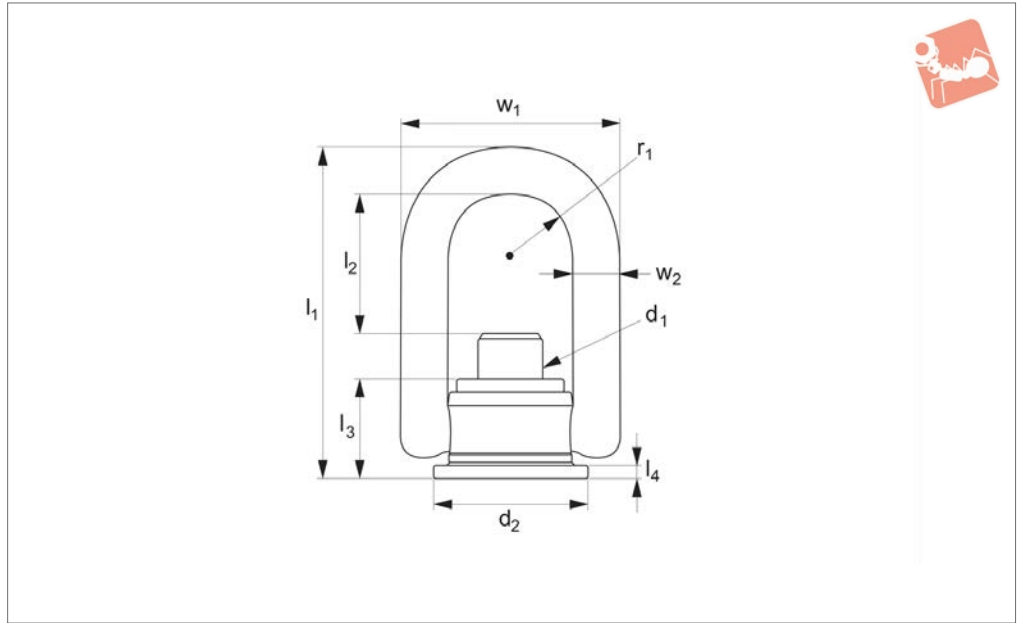

Material

Forged alloy steel, min. tensile strength 180,000 psi, black oxide coated.

Technical Notes

Magnetic particle inspected.

Tips

Min design safety factor 5:1. *Rated load

relates to components of weld mount lifting ring 63700 only. The workpiece material and weld must be capable of supporting a similar weight - please make your own appropriate checks and calculations.
360° swivel and 180° load.

Important Notes

All dimensions in imperial.
Always follow safety instructions.

Order No.	Rated load lb	d ₁	d ₂	l ₁	l ₂	l ₃	l ₄	r ₁	w ₁	w ₂
63700.W0251I	5000	5/8-11	2.45	5.47	2.46	1.63	1/4	1.00	3.50	0.75
63700.W0371I	10000	1-8	3.51	7.64	3.22	2.30	3/8	1.50	5.10	1.00
63700.W0501I	24000	1-1/4-7	4.70	9.50	3.63	3.12	1/2	2.00	6.75	1.25

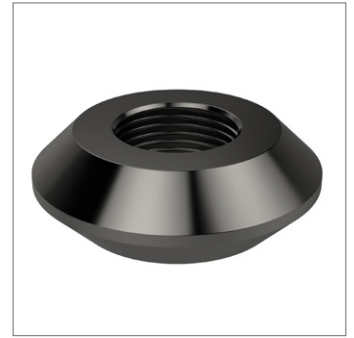
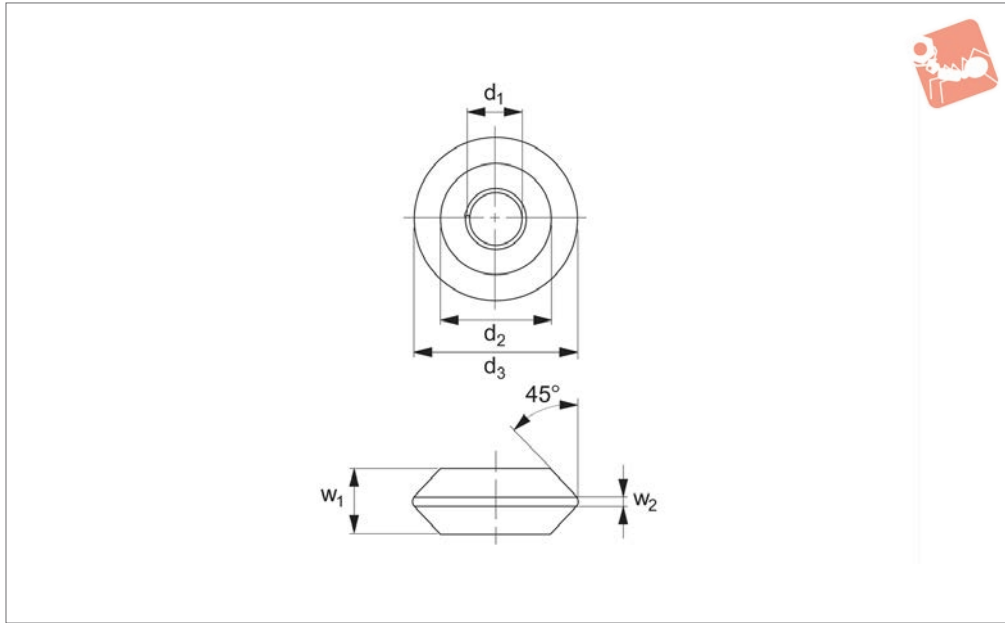

63712

LOAD RINGS & EYE BOLT

Material

High tensile steel alloy, heat treated.

Important Notes

All dimensions in imperial.

Order No.	Thread type	d_1	d_2	d_3	w_1	w_2
63712.W1251I	COIL	1-1/4	2-1/8	3	1	1/8
63712.W1501I	COIL	1-1/2	2-3/8	3-1/2	1-1/2	3/8



63760

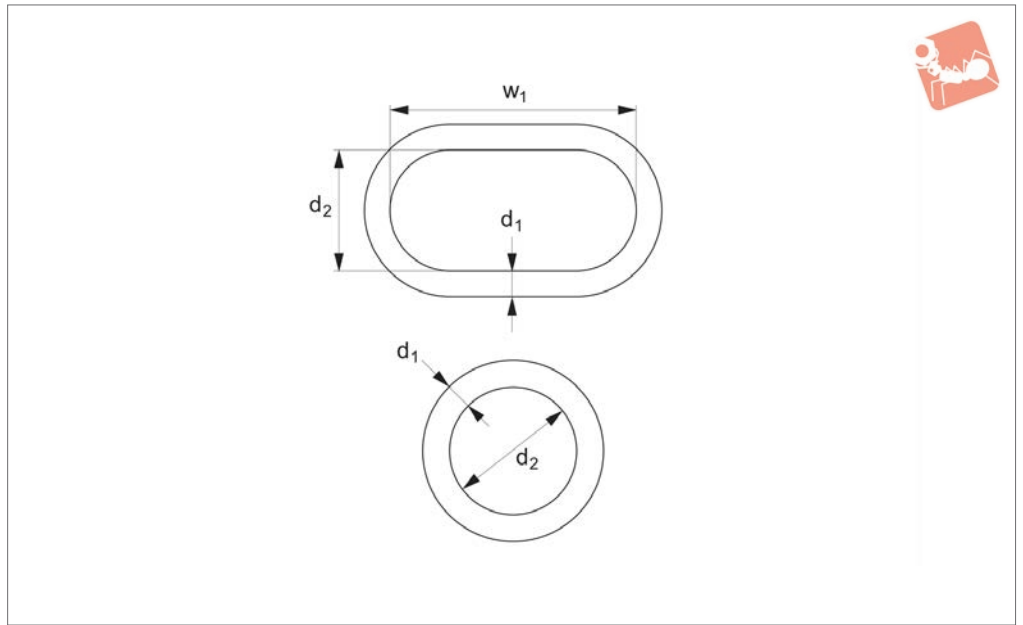

Material

Forged alloy steel, black oxide coated.

Important Notes

All dimensions in imperial.

Tips

Min. design safety factor 6:1.

Order No.	Working load lb	d_1	d_2	w_1	Weight lb
63760.W0371I	3800	3/8	2.00	-	0.23
63760.W0631I	6100	5/8	3.00	-	1.00
63760.W1371I	30000	1-3/8	6.00	-	10.38
63760.W1501I	49000	1-1/2	5.25	10.5	15.70

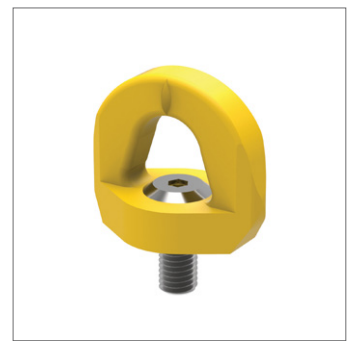
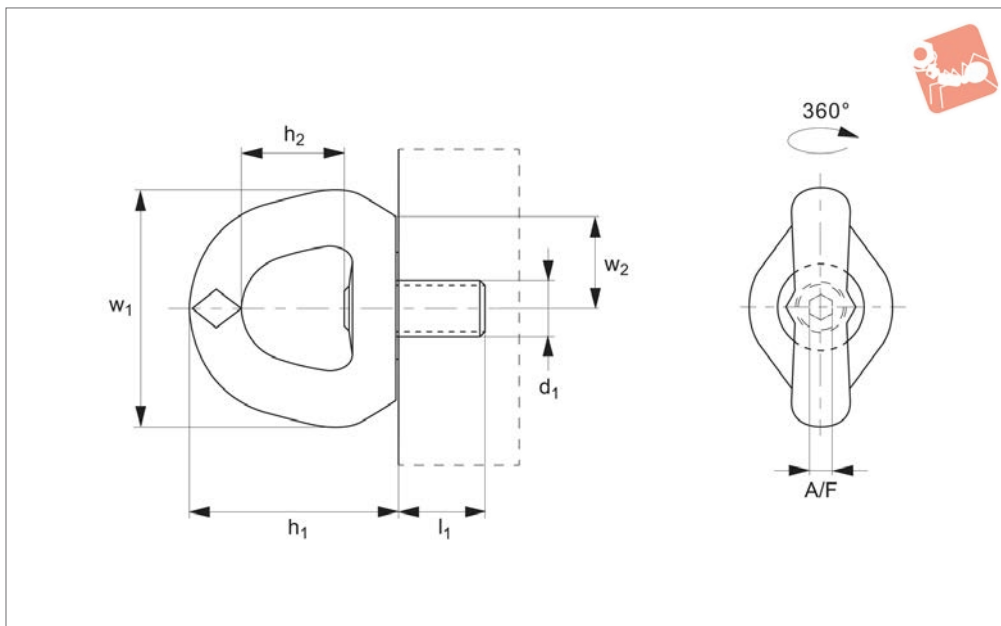

63350

LOAD RINGS & EYE BOLT

Material

High tensile corrosion resistant steel, strength class >8.
Coloured yellow to indicate personnel safety.
Supplied with CE certificate.

Technical Notes

Conforms to EN795:2012.
Single articulation, 360°.
Clearly marked with maximum number of persons. The yellow colour indicates the personnel safety use.

Tips

Marked with the number of persons the ring is certified to support.
For use by personnel wearing safety harnesses. Suitable for 1 or 2 persons as marked.
Typically used in building maintenance, wind power and offshore industries.

Important Notes

The thread diameter and depth must be appropriate to the material into which it will be installed:

Steel (min. ST37) - 1 x thread dia.
Cast iron - 1.25 x thread dia.
Aluminium - 2 x thread dia.
Other light metals - 2.5 x thread dia.
Tolerance of female thread to be 6H (metric).

Please refer to the safety documentation before using this part.

Supplied with certificate and operating instructions.

Order No.	No. of persons max.	l_1	w_1	h_1	d_1 tol. 6g	h_2	w_2	w_3	A/F	Torque to Nm	Weight kg
63350.W0012	1	21	60	57	M12x1,75	30	20	34	6	15	0.24
63350.W0016	1	27	88	80	M16x2,00	38	35	45	8	50	0.80
63350.W0020	1	30	88	80	M20x2,50	38	35	45	8	100	0.80