

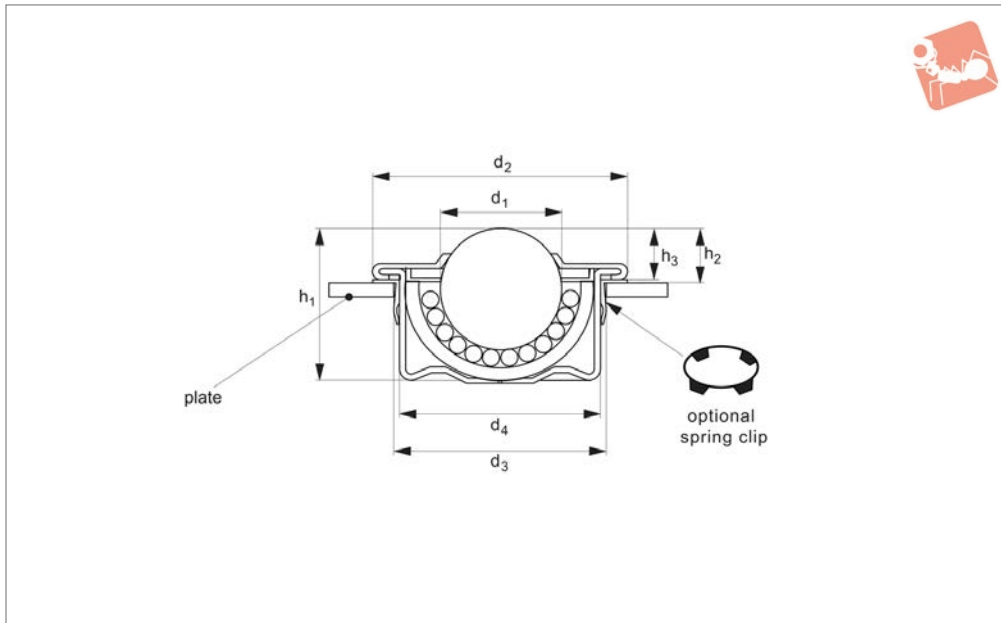

# Push-Fit Ball Transfer Units

light duty, push fit

## Transfer Rollers



**67202**

TRANSFER ROLLERS

### Material

Steel (zinc plated), stainless steel (AISI 416 for housing and AISI 420 for balls) and acetal (POM).

### Technical Notes

Cost-effective and light-weight units formed from sheet steel material. No reduction in load carrying capacity even

when installed upside down. Sizes 22 and 30 have a felt seal for the ball. Low friction 1:0,03, speeds up to 1m/s. Temperature range -20°C to +70°C.

### Tips

To compensate for irregular bore diameters we recommend using the spring clip (stainless) part no. P2730.

Clip requires a minimum plate thickness of 3mm to grip securely. These rollers can only be used in the horizontal or „ball up“ direction.

Order No.	$d_1$	$d_2$	$h_1$	$h_2$	$d_3$ min.	$d_3$ max.	$d_4$	$h_3$	Housing	Ball	Load kg max.
67202.W0151	15	31	21	10.1	25	25.5	24	9.8	Steel	Steel	60
67202.W0154	15	31	21	10.1	25	25.5	24	9.8	Steel	Stainless	60
67202.W0155	15	31	21	10.1	25	25.5	24	9.8	Steel	Acetal	10
67202.W0152	15	31	21	10.1	25	25.5	24	9.8	Stainless	Stainless	40
67202.W0221	22	45	29.5	10.4	37.0	37.5	36	10.1	Steel	Steel	160
67202.W0224	22	45	29.5	10.4	37.0	37.5	36	10.1	Steel	Stainless	160
67202.W0225	22	45	29.5	10.4	37.0	37.5	36	10.1	Steel	Acetal	20
67202.W0222	22	45	29.5	10.4	37.0	37.5	36	10.1	Stainless	Stainless	90
67202.W0301	30	55	37	14.4	46	46.5	45	14.1	Steel	Steel	280
67202.W0304	30	55	37	14.4	46	46.5	45	14.1	Steel	Stainless	280
67202.W0305	30	55	37	14.4	46	46.5	45	14.1	Steel	Acetal	25
67202.W0302	30	55	37	14.4	46	46.5	45	14.1	Stainless	Stainless	200



## 67204

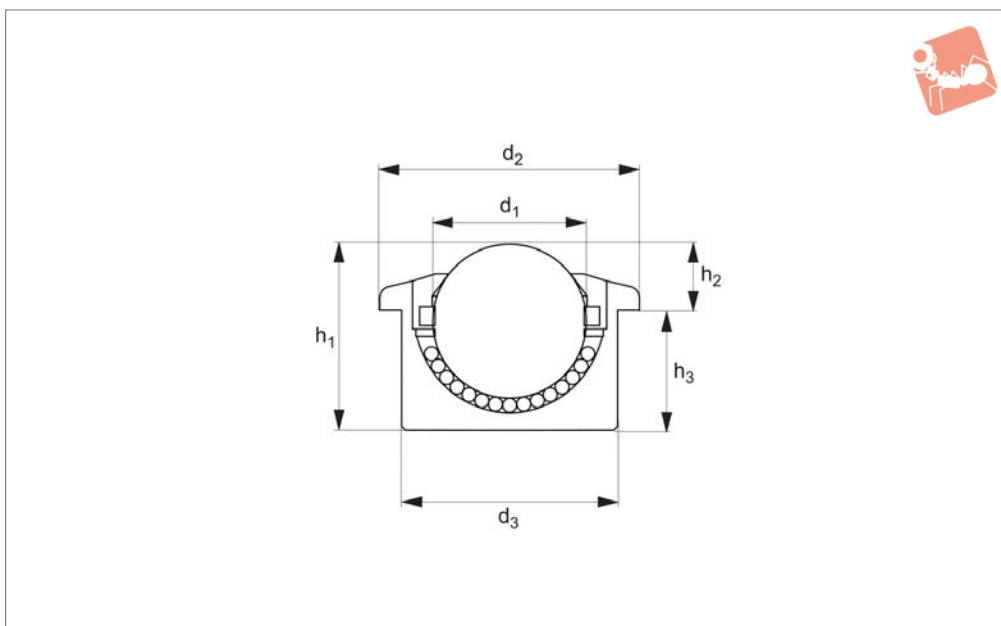

### Material

Acetal (POM) housing with acetal or stainless (AISI 316) balls.

### Technical Notes

Push-fit units, these acetal units resist

salt water and chemicals.

They are non-conductive and non-magnetic, low friction 1:0,03.

Temperature range  $-20^{\circ}\text{C}$  to  $+70^{\circ}\text{C}$ , speeds up to 1m/s.

### Tips

These rollers can only be used in the horizontal or „ball up“ direction.

Order No.	$d_1$	$d_2$	$h_1$	$h_2$	$d_3$	$h_3$	Housing	Ball
67204.W0156	15	31	21	9.5	24	11.5	Acetal	Stainless
67204.W0157	15	31	21	9.5	24	11.5	Acetal	Acetal
67204.W0226	22	45	30.5	9.8	36	20.7	Acetal	Stainless
67204.W0227	22	45	30.5	9.8	36	20.7	Acetal	Acetal
67204.W0306	30	55	37	13.8	45	23.2	Acetal	Stainless
67204.W0307	30	55	37	13.8	45	23.2	Acetal	Acetal
67204.W0456	45	75	53.5	19	62	34.5	Acetal	Stainless
67204.W0457	45	75	53.5	19	62	34.5	Acetal	Acetal



# Saturn Type Ball Transfer Units

light duty, saturn type

## Transfer Rollers

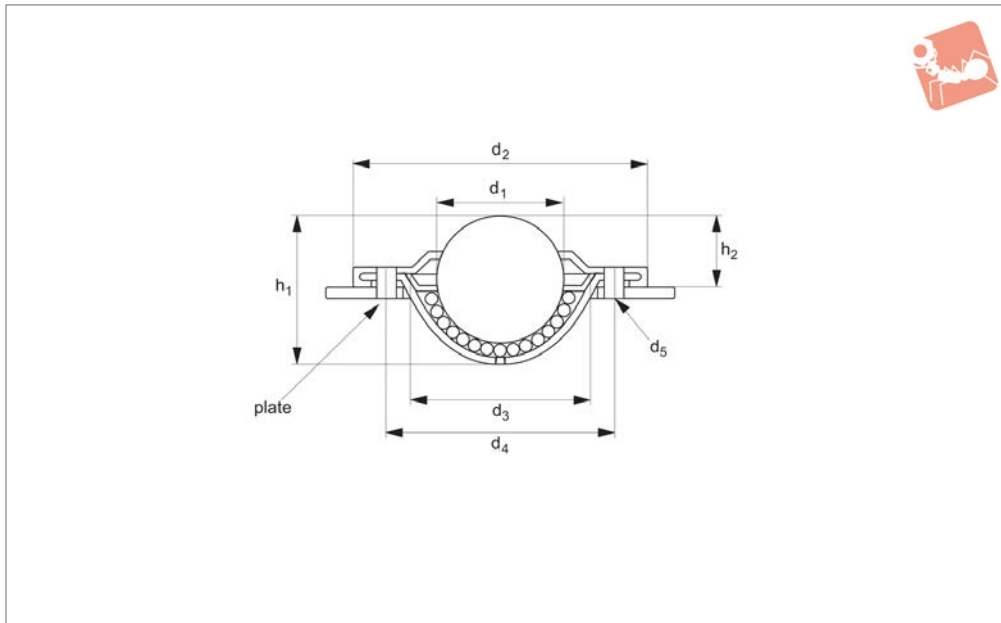

**67208**

TRANSFER ROLLERS

### Material

Steel (AISI 1040 housing and AISI 52100 for balls),  
stainless steel (AISI 416 for housing and AISI 420 for balls) and acetal (POM).

### Technical Notes

Cost-effective and light-weight units

formed from sheet steel material.

No reduction in load carrying capacity even when installed upside down.

Low friction 1:0,03, temperature range - 20°C to +70°C, speeds up to 1m/s.

### Tips

Theses rollers can only be used in the hori-

zontal or „ball up“ direction.

67208.320-SS and 67208.330-SS have 7 large fluid drain holes & no felt seal.

Order No.	d <sub>1</sub>	d <sub>2</sub>	h <sub>1</sub>	h <sub>2</sub>	d <sub>3</sub>	d <sub>4</sub>	d <sub>5</sub>	Housing	Ball	Load kg max.
<b>67208.W0161</b>	15	41.0	19.3	10.8	24.0	30.0	2 x 3,4	Steel	Steel	15
<b>67208.W0164</b>	15	41.0	19.3	10.8	24.0	30.0	2 x 3,4	Steel	Stainless	10
<b>67208.W0165</b>	15	41.0	19.3	10.8	24.0	30.0	2 x 3,4	Steel	Acetal	10
<b>67208.W0221</b>	23	45.0	27.7	9.8	33.0	39.0	3 x 3,5	Steel	Steel	120
<b>67208.W0225</b>	23	45.0	27.7	9.8	33.0	39.0	3 x 3,5	Steel	Acetal	90
<b>67208.W0322</b>	32	73.7	36.1	16.2	45.5	58.7	2 x 5,5	Stainless	Stainless	125
<b>67208.W0255</b>	25	56.0	30.0	14.6	36.0	45.0	2 x 4,0	Steel	Acetal	22
<b>67208.W0332</b>	32	74.0	36.1	16.2	46.0	58.7	3 x 5,5	Stainless	Stainless	125
<b>67208.W0224</b>	23	45.0	27.7	9.8	33.0	39.0	3 x 3,5	Steel	Stainless	22
<b>67208.W0252</b>	25	56.0	30.0	14.6	36.0	45.0	2 x 4,0	Steel	Steel	60
<b>67208.W0254</b>	25	56.0	30.0	14.6	36.0	45.0	2 x 4,0	Steel	Stainless	40
<b>67208.W0251</b>	25	47.1	29.6	14.3	38.1	-	-	Stainless	Stainless	55

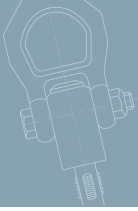

## Product selection

### Available materials

Housing	Ball	Load Factor	
Steel	Steel	1,0	Housing: AISI 1040 steel, machined, toughened & zinc plated. Ball: AISI 52100 chrome steel
Steel	Stainless	0,7	Housing: AISI 1040 steel, machined, toughened & zinc plated. Ball: AISI 420 stainless steel
Stainless	Stainless	0,7	Housing: AISI 416 stainless steel. Ball: AISI 420 stainless steel
Steel	Acetal		Housing: AISI 1040 steel, machined, toughened & zinc plated. Ball: POM acetal
Aluminium	Stainless		Housing: aluminium. Ball: AISI 420 stainless steel
Acetal	Acetal		Housing: POM acetal. Ball: POM acetal
Acetal	Stainless		Housing: POM acetal. Ball: AISI 420 stainless steel

### Fixing clip selection

Part No.	Ball Size	Minimum Bore ø	Maximum Bore ø
67202.W9015	15	24,8	25,0
67202.W9022	22	37,0	37,2
67202.W9030	30	46,3	46,7

Clip requires a minimum plate thickness of 3mm to grip securely

### How to select the correct unit

Ball Type	Max Load (Kg)	Friction (% of load)	Speed (m/s)	Shock Loads	Arduous Conditions	Orientation	Instant Change
Medium Duty	20-3500	2%	1,5	✓✓✓	✓✓		✓✓✓
Light Duty	7-250	3%	1,0	✓	✓✓		✓✓✓

### Variables to consider



**Shock Loads:**  
Specify High Capacity series & spring loaded units



**Track Hardness/Conveyed Item Material:**  
Standard material ball units have Rockwell 'C' hardness of 60 minimum



**Delicate Surfaces:**  
Ball Units - Acetal (POM) & Phenolic Resin



**Operating Environment:**  
Wet, dirty, outdoor, radioactive

### Operation temperature

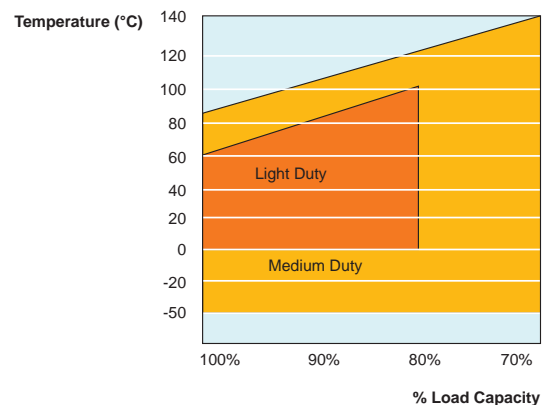

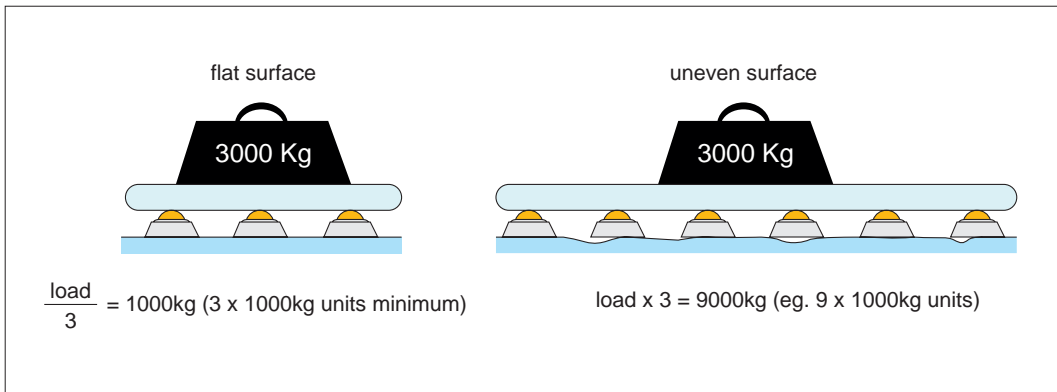

### Load and stability

To determine the load of a ball transfer unit, the weight of the article to be conveyed should be divided by 3. If the height tolerance of the load balls is good and the surface of the workpiece to be conveyed is suitable, the calculation can be based on the number of ball transfer units under the load.

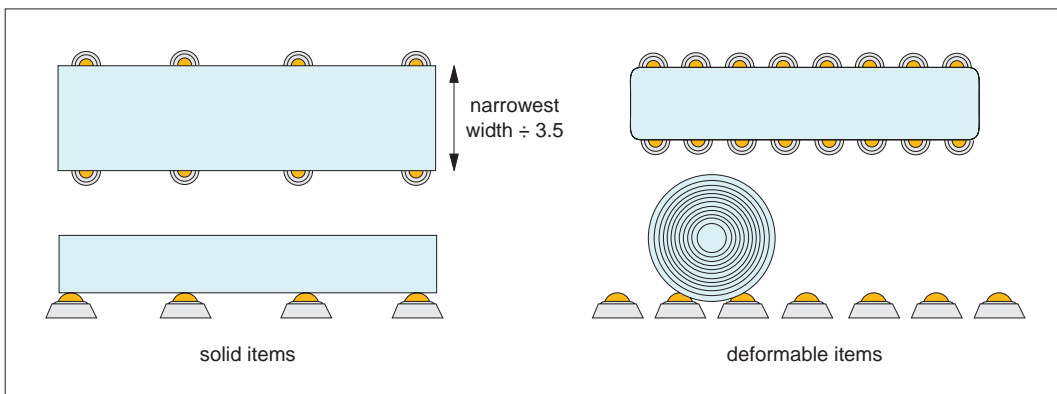

### Pitching and spacing

How the ball transfer units should be arranged depends on the bottom surface of the load to be transported. For loads with a uniform, even bottom surface, e.g. packing cases, the distance between the ball transfer units is calculated by dividing the smallest dimension by 3,5.

The maximum conveying speed allowed amounts to 2m/s. The load capacities specified apply to any mounting position and are based on  $10^6$  rotations of the load ball. With the units being used over a longer time at speeds exceeding 1m/s, an increase in temperature as well as a reduction in travel life must be expected depending on the load.

### Conveying speed and load capacity

$$L = \frac{C^3}{F} 10^6 \text{ rotations}$$

L = travel life  
C = load capacity (N)  
F = load (N)

### Calculation of travel life

The diagram shows the friction values as a function of load and speed for ball transfer units. These approximate values apply to all mounting positions with operation on a hardened steel plate.

v = 1m/s

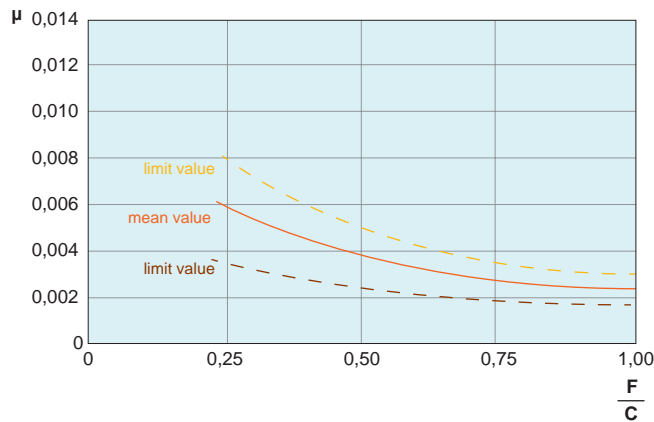

### Friction



## 67220

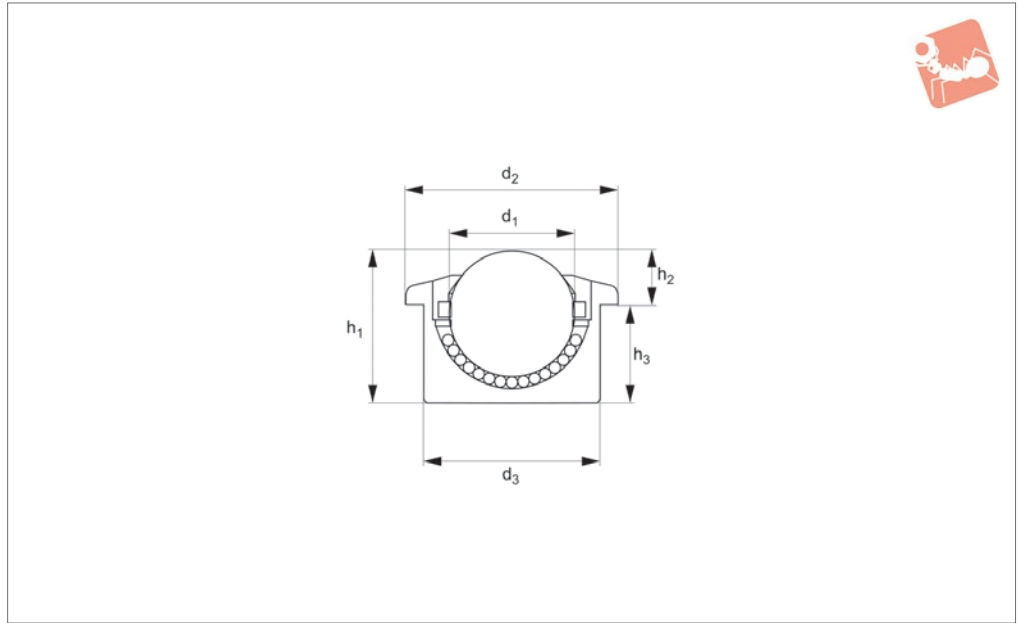

### Material

Steel (AISI 1040 housing and AISI 52100 for balls), stainless steel (AISI 416 for housing and AISI 420 for balls) and acetal (POM).

### Technical Notes

These ball transfer units are made of a solid steel block

with a precision machined hemispherical carrying bowl.  
 Top cover plates are shaped to ensure the perfect conveyance of items which have possible burred or bent edges.  
 This design also prevents possible damage to the carrying ball.  
 Provided with a hole in the base of the

bearing cup to dispose of particles of dirt and swarf (this may also be used for re-lubrication purposes).

### Tips

These rollers can only be used in the horizontal or ball up direction.

Order No.	d <sub>1</sub>	d <sub>2</sub>	h <sub>1</sub>	h <sub>2</sub>	d <sub>3</sub>	h <sub>3</sub>	Housing	Ball	Load kg max.
67220.W0454	45	75	53.5	19.0	62	34.5	Steel	Stainless	600
67220.W0304	30	55	36.8	13.8	45	23.0	Steel	Stainless	350
67220.W0254	25	46	30.5	13.0	38	17.5	Steel	Stainless	140
67220.W0224	22	45	30.5	9.8	36	20.7	Steel	Stainless	180
67220.W0154	15	30	20	8.1	24	11.9	Steel	Stainless	50
67220.W0124	12	27	16.7	8.0	22	8.7	Steel	Stainless	20
67220.W0121	12	27	16.7	8.0	22	8.7	Steel	Steel	25
67220.W0125	12	27	16.7	8.0	22	8.7	Steel	Acetal	5
67220.W0122	12	27	16.7	8.0	22	8.7	Stainless	Stainless	20
67220.W0151	15	30	20	8.1	24	11.9	Steel	Steel	60
67220.W0155	15	30	20	8.1	24	11.9	Steel	Acetal	10
67220.W0152	15	30	20	8.1	24	11.9	Stainless	Stainless	40
67220.W0161	15	31	21	9.5	24	11.5	Steel	Steel	60
67220.W0165	15	31	21	9.5	24	11.5	Steel	Acetal	10
67220.W0164	15	31	21	9.5	24	11.5	Steel	Acetal	50
67220.W0162	15	31	21	9.5	24	11.5	Stainless	Stainless	40
67220.W0221	22	45	30.5	9.8	36	20.7	Steel	Steel	180
67220.W0225	22	45	30.5	9.8	36	20.7	Steel	Acetal	20
67220.W0222	22	45	30.5	9.8	36	20.7	Stainless	Stainless	126
67220.W0251	25	46	30.5	13.0	38	17.5	Steel	Steel	200
67220.W0255	25	46	30.5	13.0	38	17.5	Steel	Acetal	25
67220.W0252	25	46	30.5	13.0	38	17.5	Stainless	Stainless	140
67220.W0301	30	55	36.8	13.8	45	23.0	Steel	Steel	350
67220.W0305	30	55	36.8	13.8	45	23.0	Steel	Acetal	25
67220.W0302	30	55	36.8	13.8	45	23.0	Stainless	Stainless	220
67220.W0451	45	75	53.5	19.0	62	34.5	Steel	Steel	600
67220.W0455	45	75	53.5	19.0	62	34.5	Steel	Acetal	25
67220.W0452	45	75	53.5	19.0	62	34.5	Stainless	Stainless	350



# Push-Fit Ball Transfer Units

medium duty

## Transfer Rollers



Order No.	d <sub>1</sub>	d <sub>2</sub>	h <sub>1</sub>	h <sub>2</sub>	d <sub>3</sub>	h <sub>3</sub>	Housing	Ball	Load kg max.
<b>67220.W0601</b>	60	117	77.5	30.0	100	47.5	Steel	Steel	1500
<b>67220.W0605</b>	60	117	77.5	30.0	100	47.5	Steel	Acetal	35
<b>67220.W0602</b>	60	117	77.5	30.0	100	47.5	Stainless	Stainless	1050

TRANSFER ROLLERS

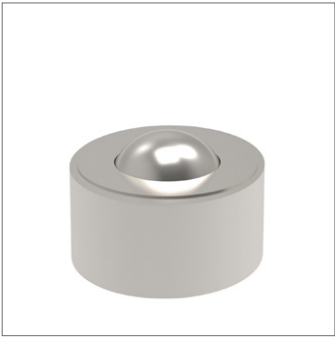

### 67222

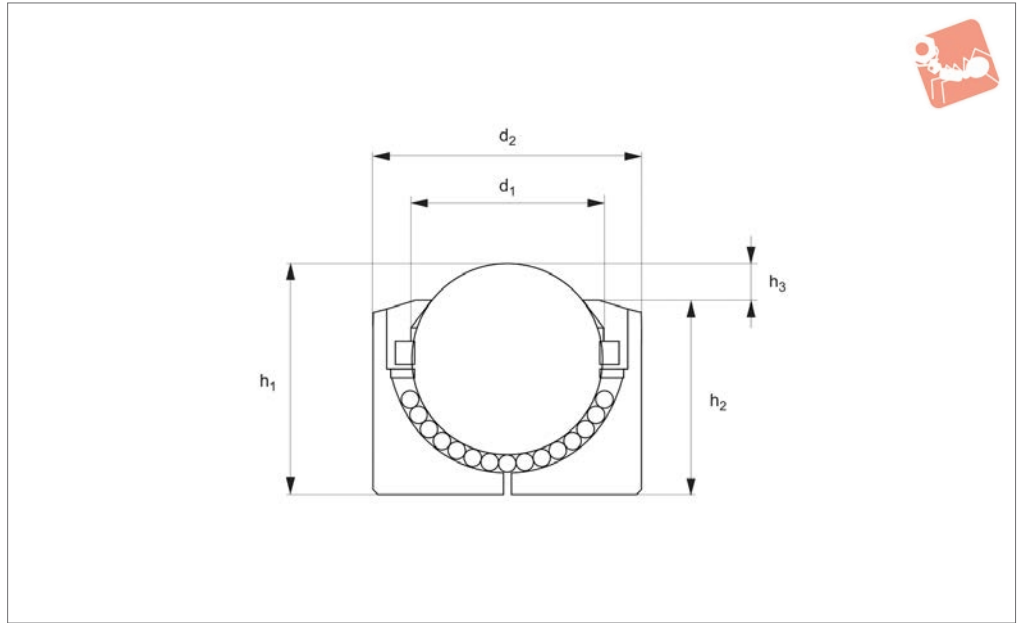

#### Material

Steel (AISI 1040 housing and AISI 52100 for balls),  
stainless steel (AISI 416 for housing and AISI 420 for balls) and acetal (POM).

#### Technical Notes

These ball transfer units are made of a solid steel block with a precision machined hemispherical carrying bowl.

Top cover plates are shaped to ensure the perfect conveyance of items which have possible burred or bent edges. This design also prevents possible damage to the carrying ball.

Provided with a hole in the base of the bearing cup to dispose of particles of dirt and swarf (this may also be used for re-lubrication purposes).

Manufactured without a flange on the housing, therefore the whole load is being supported only by the bottom face of the unit.

#### Tips

These rollers can only be used in the horizontal or „ball up“ direction.

Order No.	$d_1$	$d_2$	$h_1$	$h_2$	$h_3$	Housing	Ball	Load kg max.
67222.W0081	8	18	12.0	10.0	2.0	Steel	Steel	13
67222.W0084	8	18	12.0	10.0	2.0	Steel	Stainless	10
67222.W0082	8	18	12.0	10.0	2.0	Stainless	Stainless	8.4
67222.W0124	12	20	16.5	13.5	3.0	Steel	Stainless	20
67222.W0154	15	24	20.0	15.0	5.0	Steel	Stainless	50
67222.W0224	22	36	30.5	27.9	4.5	Steel	Stainless	180
67222.W0304	30	45	36.8	30.3	6.5	Steel	Stainless	350
67222.W0454	45	62	53.5	45.0	8.5	Steel	Stainless	600
67222.W0604	60	100	77.5	61	16.5	Steel	Stainless	1100
67222.W0121	12	20	16.5	13.5	3.0	Steel	Steel	25
67222.W0125	12	20	16.5	13.5	3.0	Steel	Acetal	5
67222.W0122	12	20	16.5	13.5	3.0	Stainless	Stainless	14
67222.W0151	15	24	20.0	15.0	5.0	Steel	Steel	60
67222.W0155	15	24	20.0	15.0	5.0	Steel	Acetal	10
67222.W0152	15	24	20.0	15.0	5.0	Stainless	Stainless	40
67222.W0221	22	36	30.5	27.9	4.5	Steel	Steel	180
67222.W0225	22	36	30.5	27.9	4.5	Steel	Acetal	20
67222.W0222	22	36	30.5	27.9	2.6	Stainless	Stainless	125
67222.W0301	30	45	36.8	30.3	6.5	Steel	Steel	350
67222.W0305	30	45	36.8	30.3	6.5	Steel	Acetal	25
67222.W0302	30	45	36.8	30.3	6.5	Stainless	Stainless	245
67222.W0451	45	62	53.5	45.0	8.5	Steel	Steel	600
67222.W0455	45	62	53.5	45.0	8.5	Steel	Acetal	25
67222.W0452	45	62	53.5	45.0	8.5	Stainless	Stainless	420
67222.W0601	60	100	77.5	61	16.5	Steel	Steel	1500





# Plain-Fit Ball Transfer Units

medium duty

## Transfer Rollers



Order No.	d <sub>1</sub>	d <sub>2</sub>	h <sub>1</sub>	h <sub>2</sub>	h <sub>3</sub>	Housing	Ball	Load kg max.
<b>67222.W0605</b>	60	100	77.5	61	16.5	Steel	Acetal	35
<b>67222.W0602</b>	60	100	77.5	61	16.5	Stainless	Stainless	1000

TRANSFER ROLLERS



## 67224

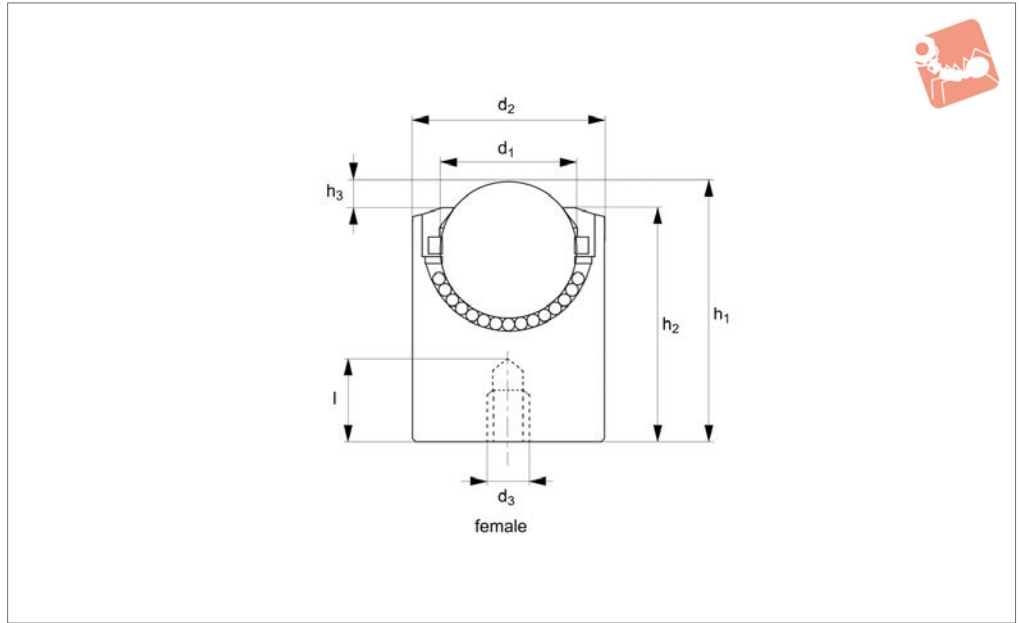

### Material

Steel (AISI 1040 housing and AISI 52100 for balls),  
stainless steel (AISI 416 for housing and AISI 420 for balls) and acetal (POM).

### Technical Notes

These ball transfer units are made of a solid steel block with a precision machined hemispherical

carrying bowl.

Top cover plates are shaped to ensure the perfect conveyance of items which have possible burred or bent edges. This design also prevents possible damage to the carrying ball.

Provided with a hole in the base of the bearing cup to dispose of particles of dirt and swarf

(this may also be used for re-lubrication purposes).  
Manufactured without a flange on the housing, therefore the whole load is being supported only by the bottom face of the unit.

### Tips

For male version see .

Order No.	Type	d <sub>1</sub>	d <sub>2</sub>	h <sub>1</sub>	h <sub>2</sub>	d <sub>3</sub>	h <sub>3</sub>	l <sub>1</sub>	Housing	Ball	Load kg max.
67224.W1121	Female	12	22	24.0	20.5	M8	3.5	5	Steel	Steel	25
67224.W1125	Female	12	22	24.0	20.5	M8	3.5	5	Steel	Acetal	5
67224.W1122	Female	12	22	24.0	20.5	M8	3.5	5	Stainless	Stainless	17
67224.W1124	Female	12	22	24.0	20.5	M8	3.5	5	Steel	Stainless	20
67224.W1224	Female	22	36	40.5	34	M8	4.5	10	Steel	Stainless	180
67224.W1454	Female	45	62	63.5	50.5	M8	13.0	10	Steel	Stainless	600
67224.W1304	Female	30	45	46.8	38.8	M8	8.0	10	Steel	Stainless	350
67224.W1154	Female	15	24	28.0	23	M8	5.0	8	Steel	Stainless	50
67224.W1151	Female	15	24	28.0	23	M8	5.0	8	Steel	Steel	60
67224.W1155	Female	15	24	28.0	23	M8	5.0	8	Steel	Acetal	10
67224.W1152	Female	15	24	28.0	23	M8	5.0	8	Stainless	Stainless	40
67224.W1221	Female	22	36	40.5	34	M8	4.5	10	Steel	Steel	180
67224.W1225	Female	22	36	40.5	34	M8	4.5	10	Steel	Acetal	20
67224.W1222	Female	22	36	40.5	34	M8	4.5	10	Stainless	Stainless	126
67224.W1301	Female	30	45	46.8	38.8	M8	8.0	10	Steel	Steel	350
67224.W1305	Female	30	45	46.8	38.8	M8	8.0	10	Steel	Acetal	25
67224.W1302	Female	30	45	46.8	38.8	M8	8.0	10	Stainless	Stainless	245
67224.W1451	Female	45	62	63.5	50.5	M8	13.0	10	Steel	Steel	600
67224.W1455	Female	45	62	63.5	50.5	M8	13.0	10	Steel	Acetal	25
67224.W1452	Female	45	62	63.5	50.5	M8	13.0	10	Stainless	Stainless	420

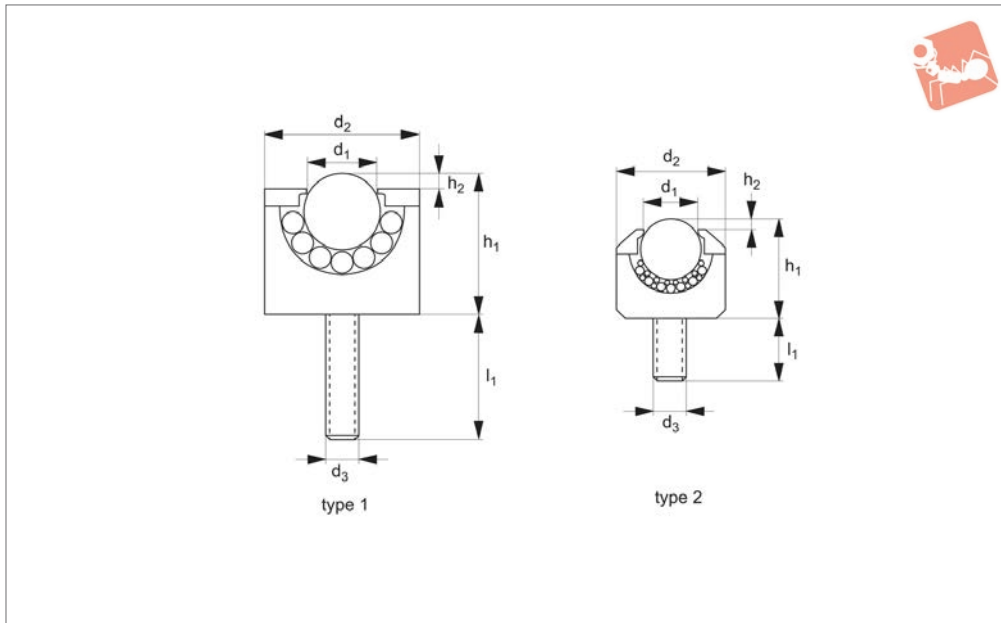

**67200**

TRANSFER ROLLERS

### Material

Carbon steel, aluminium or stainless steel housing. Carbon steel or stainless steel balls.

### Technical Notes

All steel parts are supplied with a small

amount of oil, to protect from oxidation.

### Tips

Normally used in measuring equipment, small linear motion systems (e.g photocopy slides) and miniature mechanisms.

Order No.	Type	d <sub>1</sub>	d <sub>2</sub>	h <sub>1</sub>	h <sub>2</sub>	d <sub>3</sub>	h <sub>3</sub>	Housing	Ball	Load kg max.
67200.W0051	type 1	4.8	13	9	1	M6	15	Steel	Steel	10
67200.W0151	type 1	15.8	28	20.5	4	M6	12	Steel	Steel	70
67200.W0152	type 1	15.8	24	20.5	4	M6	12	Stainless	Stainless	70
67200.W0162	type 1	15.8	24	20.5	4	M6	12	Stainless	Stainless	70
67200.W0052	type 1	4.8	13	9	1	M6	15	Stainless	Stainless	10
67200.W0053	type 2	4.8	8	6	1	M2	2.5	Aluminium	Stainless	5
67200.W0072	type 1	6.4	17	11	2	M6	15	Stainless	Stainless	20
67200.W0065	type 2	6.4	13	10.5	2	M3	6	Aluminium	Stainless	10
67200.W0082	type 1	8	18	12	2	M6	15	Stainless	Stainless	30
67200.W0093	type 2	7.9	15	12.5	2	M4	8	Aluminium	Stainless	15
67200.W0101	type 1	9.6	23	20	2	M8	20	Steel	Steel	40
67200.W0102	type 1	9.6	23	20	2	M8	20	Stainless	Stainless	40
67200.W0131	type 1	12.7	28	25	3.5	M8	23	Steel	Steel	50
67200.W0132	type 1	12.7	28	25	3.5	M8	23	Stainless	Stainless	50