

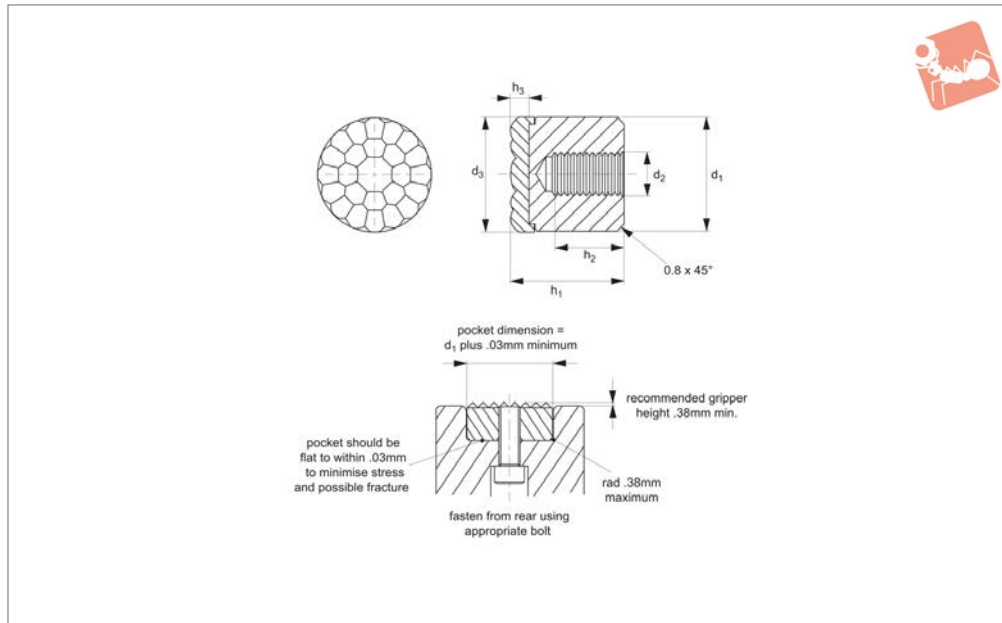

Grippers - Urethane Coated female threaded housing

Grippers & Rest Pads



35610

GRIPPERS & REST PADS

Material

Body: AISI 300 series stainless steel.
Pad: urethane; non-marking, non-staining

Technical Notes

Non-marking, non-staining urethane pad is permanently bonded to the stainless

steel body. Available in three different durometers: 35, 60 & 80 (see table).
Bubbled texture of urethane pad allows air to escape so avoiding any suction action.

Important Notes

Load compression ratings based on load

required to compress urethane surface 0,812mm for 2mm thick pad. Compression ratings vary greatly depending upon temperature and other application-specific factors.

Order No.	d_1 +0.00 -0.13	d_2	d_3	h_1	h_2	Urethane thickness h_3	Durometer	Load compression kg
35610.W0083	8	M 4x0,7	8	12	6	2	35	4
35610.W0086	8	M 4x0,7	8	12	6	2	60	13
35610.W0088	8	M 4x0,7	8	12	6	2	80	20
35610.W0103	10	M 5x0,8	10	12	6	2	35	5
35610.W0106	10	M 5x0,8	10	12	6	2	60	15
35610.W0108	10	M 5x0,8	10	12	6	2	80	40
35610.W0123	12	M 5x0,8	13	12	6	2	35	18
35610.W0126	12	M 5x0,8	13	12	6	2	60	34
35610.W0128	12	M 5x0,8	13	12	6	2	80	86
35610.W0163	16	M 6x1,0	16	12	6	2	35	36
35610.W0166	16	M 6x1,0	16	12	6	2	60	72
35610.W0168	16	M 6x1,0	16	12	6	2	80	117
35610.W0203	20	M 6x1,0	21	12	6	3	35	38
35610.W0206	20	M 6x1,0	21	12	6	3	60	104
35610.W0208	20	M 6x1,0	21	12	6	3	80	165
35610.W0253	25	M 6x1,0	27	12	6	3	35	65
35610.W0256	25	M 6x1,0	27	12	6	3	60	136
35610.W0258	25	M 6x1,0	27	12	6	3	80	272

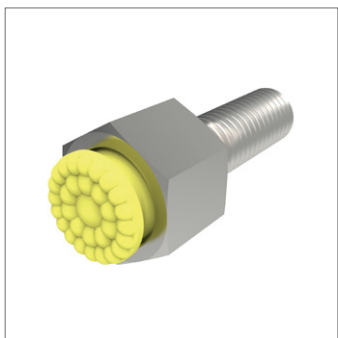

35620

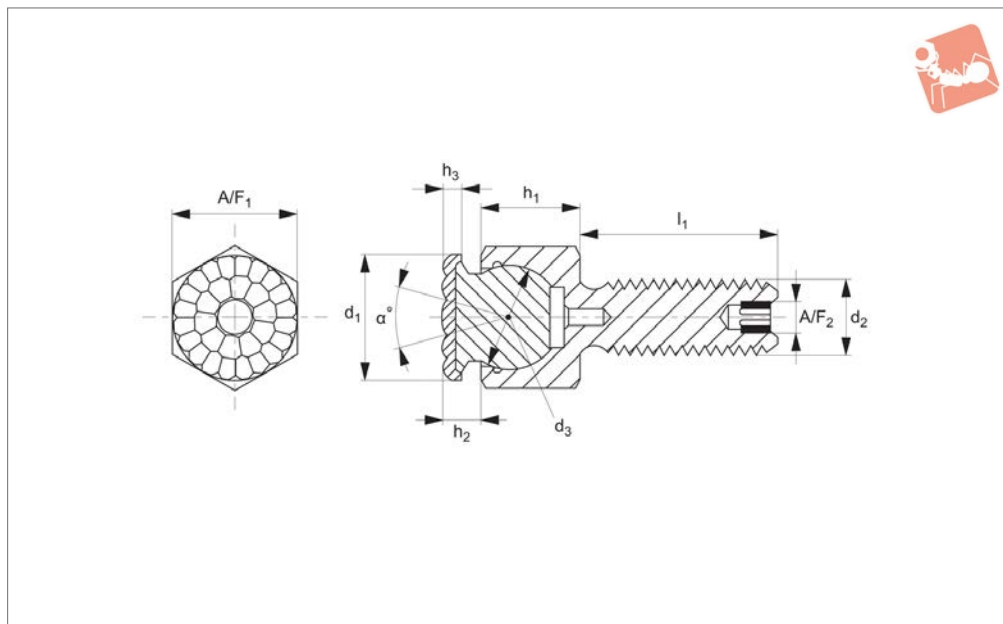

Material

Housing body: alloy steel, heat treated to HRc 43-46, black oxide finish.

Pad: urethane, bonded to AISI 300 series stainless steel ball.

Technical Notes

Non-marking, non-staining urethane pad is permanently bonded to the stainless

steel body. Available in three different durometers: 35, 60 & 80 (see table).
Bubbled texture of urethane pad allows air to escape so avoiding any suction action.

Tips

Re-seating: expel air by using 0,3 monofilament line between ball and housing, remove line when seated correctly.

Important Notes

Load compression ratings based on load required to compress urethane surface 0,812mm for 2mm thick pad. Compression ratings vary greatly depending upon temperature and other application-specific factors.

Order No.	d ₁	d ₂	l ₁	d ₃	h ₁ ±0.05	h ₂	A/F ₁	A/F ₂	Urethane thickness	h ₃	Durometer	Swivel angle α	Load compression kg
35620.W3062	10	M 6x1,0	25	7	8.0	4	10	-	2	35	28	3	
35620.W3063	10	M 6x1,0	40	7	8.0	4	10	-	2	35	28	3	
35620.W3121	21	M12x1,75	20	15	15.0	6	19	5	2	35	24	68	
35620.W6061	10	M 6x1,0	12	7	8.0	4	10	-	2	60	28	11	
35620.W6062	10	M 6x1,0	25	7	8.0	4	10	-	2	60	28	11	
35620.W6063	10	M 6x1,0	40	7	8.0	4	10	-	2	60	28	11	
35620.W6081	13	M 8x1,25	12	10	11.5	5	13	-	2	60	28	34	
35620.W6082	13	M 8x1,25	25	10	11.5	5	13	-	2	60	28	34	
35620.W6083	13	M 8x1,25	40	10	11.5	5	13	-	2	60	28	34	
35620.W6101	16	M10x1,5	15	13	13.0	5	17	3	2	60	28	65	
35620.W6102	16	M10x1,5	30	13	13.0	5	17	3	2	60	28	65	
35620.W6103	16	M10x1,5	50	13	13.0	5	17	3	2	60	28	65	
35620.W6121	21	M12x1,75	20	15	15.0	6	19	5	2	60	24	154	
35620.W6122	21	M12x1,75	40	15	15.0	6	19	5	2	60	24	154	
35620.W6123	21	M12x1,75	60	15	15.0	6	19	5	2	60	24	154	
35620.W6161	23	M16x2,0	25	20	19.0	6	24	6	2	60	24	181	
35620.W6162	23	M16x2,0	50	20	19.0	6	24	6	2	60	24	181	
35620.W6163	23	M16x2,0	80	20	19.0	6	24	6	2	60	24	181	
35620.W8061	10	M 6x1,0	12	7	8.0	4	10	-	2	80	28	29	
35620.W8062	10	M 6x1,0	25	7	8.0	4	10	-	2	80	28	29	
35620.W8063	10	M 6x1,0	40	7	8.0	4	10	-	2	80	28	29	
35620.W8081	13	M 8x1,25	12	10	11.5	5	13	-	2	80	28	68	
35620.W8082	13	M 8x1,25	25	10	11.5	5	13	-	2	80	28	68	
35620.W8083	13	M 8x1,25	40	10	11.5	5	13	-	2	80	28	68	
35620.W8101	16	M10x1,5	15	13	13.0	5	17	3	2	80	28	97	
35620.W8102	16	M10x1,5	30	13	13.0	5	17	3	2	80	28	97	
35620.W8103	16	M10x1,5	50	13	13.0	5	17	3	2	80	28	97	
35620.W8121	21	M12x1,75	20	15	15.0	6	19	5	2	80	24	238	
35620.W8122	21	M12x1,75	40	15	15.0	6	19	5	2	80	24	238	



Grippers - Self Aligning urethane coated - threaded bolt

Grippers & Rest Pads



Order No.	d ₁	d ₂	l ₁	d ₃	h ₁ ±0.05	h ₂	A/F ₁	A/F ₂	Urethane thickness h ₃	Durometer	Swivel angle a °	Load compression kg
35620.W8123	21	M12x1,75	60	15	15.0	6	19	5	2	80	24	238
35620.W8161	23	M16x2,0	25	20	19.0	6	24	6	2	80	24	272
35620.W8162	23	M16x2,0	0	20	19.0	6	24	6	2	80	24	272
35620.W8163	23	M16x2,0	80	20	19.0	6	24	6	2	80	24	272



35622

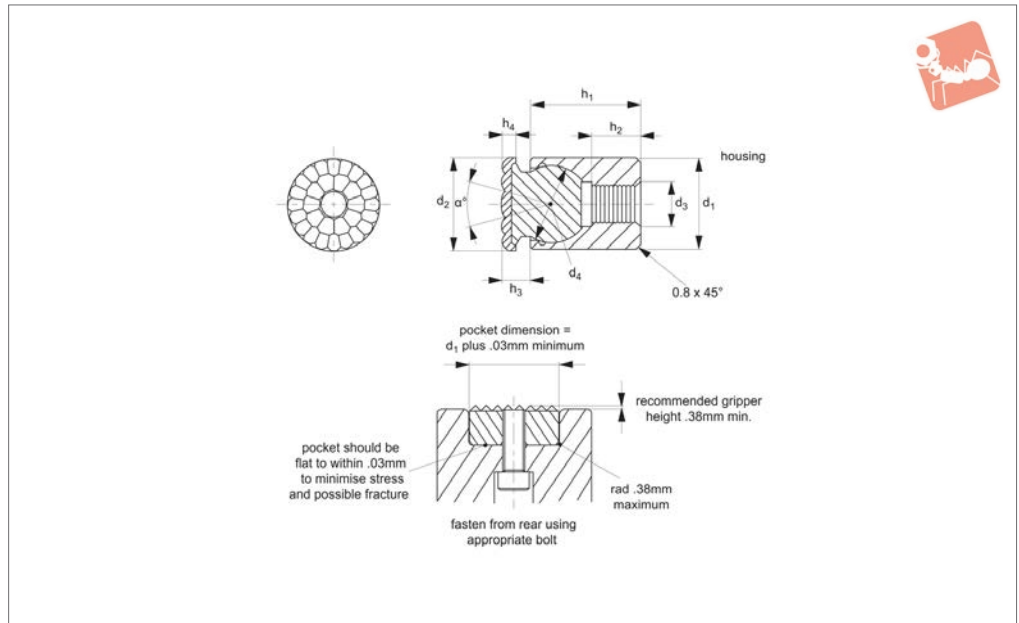

Material

Housing body: alloy steel, heat treated to HRC 43-46, black oxide finish.
 Pad: urethane, bonded to AISI 300 series stainless steel ball.

Technical Notes

Non-marking, non-staining urethane pad is permanently bonded to the stainless

steel body. Available in three different durometers: 35, 60 & 80 (see table).
 Bubbled texture of urethane pad allows air to escape so avoiding any suction action.

Tips

Re-seating: expel air by using 0,3 monofilament line between ball and housing, remove line when seated correctly.

Important Notes

Load compression ratings based on load required to compress urethane surface 0,812mm for 2mm thick pad. Compression ratings vary greatly depending upon temperature and other application-specific factors.

Order No.	d_1 +0.00 -0.13	d_2	d_3	d_4	h_1 ± 0.05	h_2 ± 0.25	h_3	Urethane thickness h_4	Durometer	Swivel angle α	Load compression kg
35622.W3041	10	10	M 4x0,7	7	10.5	3.5	4	2	35	28	3
35622.W3042	10	10	M 4x0,7	7	23.5	9.0	4	2	35	28	3
35622.W3051	13	13	M 5x0,8	10	14.5	6.5	5	2	35	28	18
35622.W3052	13	13	M 5x0,8	10	23.5	9.0	5	2	35	28	18
35622.W3061	17	16	M 6x1,0	13	18.0	7.5	5	2	35	28	24
35622.W3081	19	21	M 8x1,25	15	20.0	8.5	6	2	35	24	68
35622.W3101	24	23	M10x1,5	20	24.0	9.0	6	2	35	24	102
35622.W6041	10	10	M 4x0,7	7	10.5	3.5	4	2	60	28	11
35622.W6042	10	10	M 4x0,7	7	23.5	9.0	4	2	60	28	11
35622.W6051	13	13	M 5x0,8	10	14.5	6.5	5	2	60	28	34
35622.W6052	13	13	M 5x0,8	10	23.5	9.0	5	2	60	28	34
35622.W6061	17	16	M 6x1,0	13	18.0	7.5	5	2	60	28	63
35622.W6081	19	21	M 8x1,25	15	20.0	8.5	6	2	60	24	154
35622.W6101	24	23	M10x1,5	20	24.0	9.0	6	2	60	24	181
35622.W8041	10	10	M 4x0,7	7	10.5	3.5	4	2	80	28	29
35622.W8042	10	10	M 4x0,7	7	23.5	9.0	4	2	80	28	29
35622.W8051	13	13	M 5x0,8	10	14.5	6.5	5	2	80	28	68
35622.W8052	13	13	M 5x0,8	10	23.5	9.0	5	2	80	28	68
35622.W8061	17	16	M 6x1,0	13	18.0	7.5	5	2	80	28	97
35622.W8081	19	21	M 8x1,25	15	20.0	8.5	6	2	80	24	238
35622.W8101	24	23	M10x1,5	20	24.0	9.0	6	2	80	24	272



Grippers - Self Aligning

set screw - urethane coated

Grippers & Rest Pads

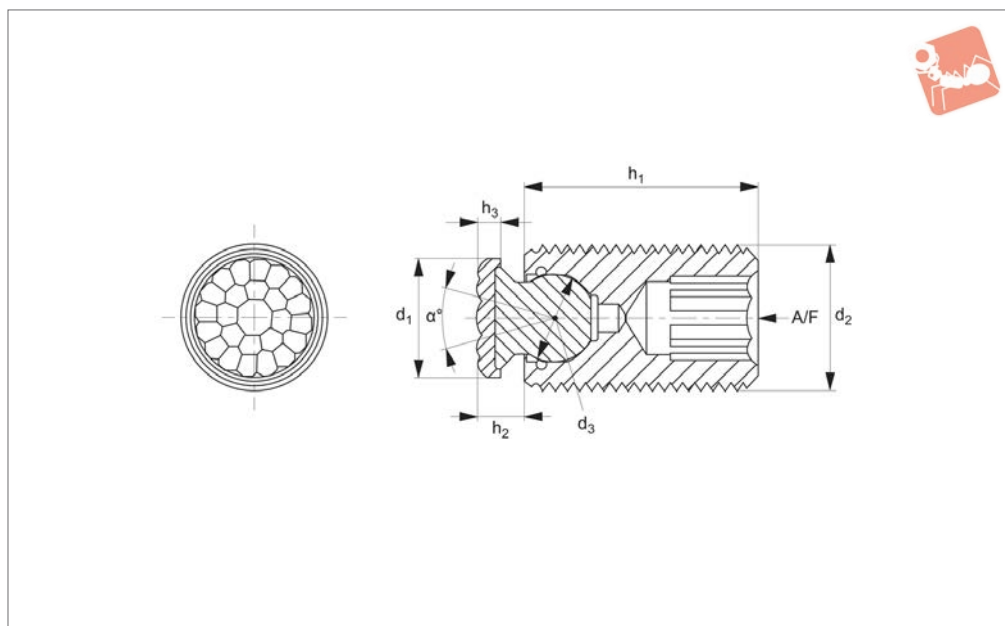

35624

GRIPPERS & REST PADS

Material

Housing body: alloy steel, heat treated to HRC 43-46, black oxide finish.

Pad: urethane, bonded to AISI 300 series stainless steel ball.

Technical Notes

Available in three different durometers:

35, 60 & 80 (see table).

Bubbled texture of urethane pad allows air to escape so avoiding any suction action.

Tips

Re-seating: expel air by using 0,3 monofilament line between ball and housing, remove line when seated correctly.

Important Notes

Load compression ratings based on load required to compress urethane surface 0,812mm for 2mm thick pad. Compression ratings vary greatly depending upon temperature and other application-specific factors.

Order No.	d ₁	d ₂	d ₃	h ₁	h ₂	h ₃	A/F	Durometer	Swivel angle α °	Load compression kg
35624.W6101	8	M10x1,5	5	25	3,5	2	5	60	28	9
35624.W6102	8	M10x1,5	5	35	3,5	2	5	60	28	9
35624.W6103	8	M10x1,5	5	50	3,5	2	5	60	28	9
35624.W6121	10	M12x1,75	7	25	4,0	2	6	60	28	11
35624.W6122	10	M12x1,75	7	35	4,0	2	6	60	28	11
35624.W6123	10	M12x1,75	7	50	4,0	2	6	60	28	11
35624.W6161	13	M16x2,0	10	25	5,0	2	8	60	28	34
35624.W6162	13	M16x2,0	10	35	5,0	2	8	60	28	34
35624.W6163	13	M16x2,0	10	50	5,0	2	8	60	28	34
35624.W6201	16	M20x2,5	13	30	5,0	2	10	60	28	63
35624.W6202	16	M20x2,5	13	50	5,0	2	10	60	28	63
35624.W6203	16	M20x2,5	13	70	5,0	2	10	60	28	63
35624.W6241	21	M24x3,0	15	40	6,0	2	10	60	24	154
35624.W6242	21	M24x3,0	15	80	6,0	2	10	60	24	154
35624.W8101	8	M10x1,5	5	25	3,5	2	5	80	28	18
35624.W8102	8	M10x1,5	5	35	3,5	2	5	80	28	18
35624.W8103	8	M10x1,5	5	50	3,5	2	5	80	28	18
35624.W8121	10	M12x1,75	7	25	4,0	2	6	80	28	29
35624.W8122	10	M12x1,75	7	35	4,0	2	6	80	28	29
35624.W8123	10	M12x1,75	7	50	4,0	2	6	80	28	29
35624.W8161	13	M16x2,0	10	25	5,0	2	8	80	28	68
35624.W8162	13	M16x2,0	10	35	5,0	2	8	80	28	68
35624.W8163	13	M16x2,0	10	50	5,0	2	8	80	28	68
35624.W8201	16	M20x2,5	13	30	5,0	2	10	80	28	97
35624.W8202	16	M20x2,5	13	50	5,0	2	10	80	28	97
35624.W8203	16	M20x2,5	13	70	5,0	2	10	80	28	97
35624.W8241	21	M24x3,0	15	40	6,0	2	10	80	24	238
35624.W8242	21	M24x3,0	15	80	6,0	2	10	80	24	238

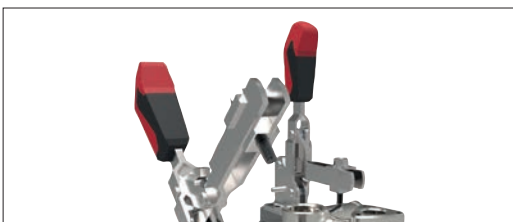

Grippers enhance workholding for multiple machining operations.

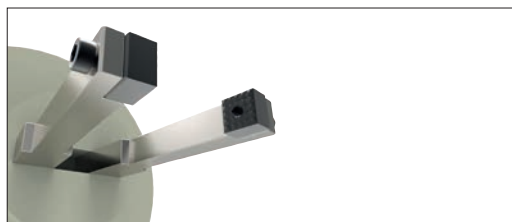

Grippers increase handling capability.

Pads and Gripper Options

Pads

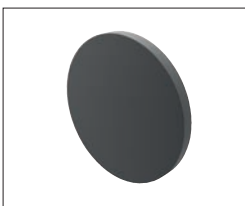

Solid Carbide

High impact carbide pads, can be brazed or bonded into place.



Carbide Tipped

Constructed with high impact carbide pad brazed to a heat treated alloy steel body. Mount via tapped hole or a flat on the outside diameter for set screw mounting.



Hardened Steel

Made from 8620 steel, carburized and hardened to Rc 58/60 1.2mm with black oxide finish. Mount via tapped or counter bored hole.



Non-marking Thermoplast

Made from white thermoplast. Mount via tapped or counter bored hole.



Stainless Steel

Pad from 17-4 stainless steel, hardened to Rc 43/46. Mount via tapped or counter bored hole.



Abrasive Diamond Surface

Abrasive surface permanently fused to a 17-4 stainless steel pad, hardened to Rc 43/46. The surface texture is comparable to a 100 grit abrasive. Mount via tapped or counter bored hole.



Soft Urethane Surface

Urethane surface is permanently bonded to a 300 series stainless steel pad. The urethane provides excellent protection against damage on delicate work surfaces. Tapped hole mounting.

see our website for our full range:
wixroyd.com

Grippers

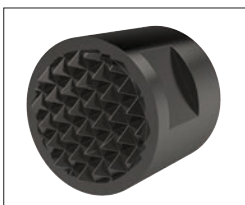

High Speed Tool Steel

Manufactured from M-2 high speed tool steel, hardened to Rc 60/62 with black oxide finish. Mount via tapped hole, counter bored hole or a flat on the outside diameter for set screw mounting.

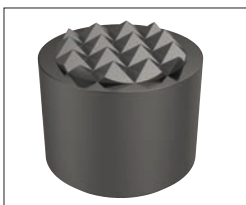

Carbide Tipped

Constructed with high impact carbide pad brazed to a heat treated alloy steel body. Mounts via tapped hole or a flat on the outside diameter for set screw mounting.

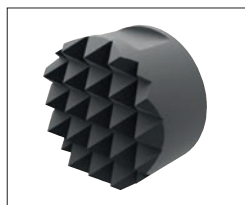

Solid Carbide

Manufactured from high impact carbide in a solid gripper pad or as a solid gripper body with a threaded brazed-in steel insert. Mount via tapped hole or a flat on the outside diameter for set screw mounting.



A Range of Specialist Gripping Pads to Suit Your Application



Unique urethane coat prevents marking of delicate components during machining or manipulation by robots. The urethane pad is permanently bonded to the stainless steel body of the gripping pad. With a bubbled texture, air is able to escape and hence avoid any suction action - enabling easy releasing of parts.

Urethane Coated

These are available in three different urethane durometers.



35 durometer:
Pencil rubber top



60 durometer:
Car tyre



80 durometer:
Skateboard wheel

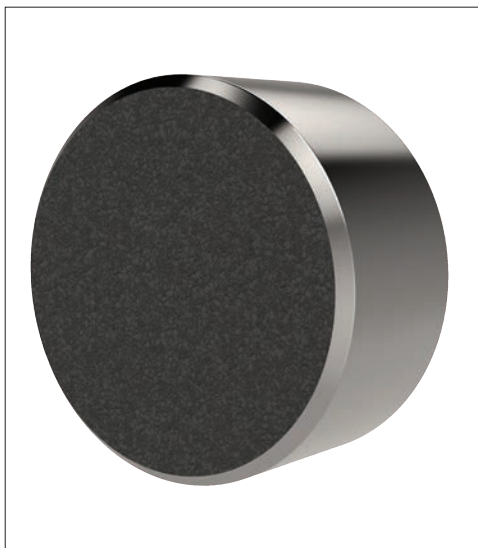

To improve handling of smooth or slippery components, with a minimum of clamping pressure, our abrasive diamond coated pads provide an excellent solution.

Abrasive Diamond Coated

Diamond powders are permanently fused to a 17-4 stainless pad, to provide an abrasive surface comparable to 100 grit value.



Sandpaper of 100
grit texture

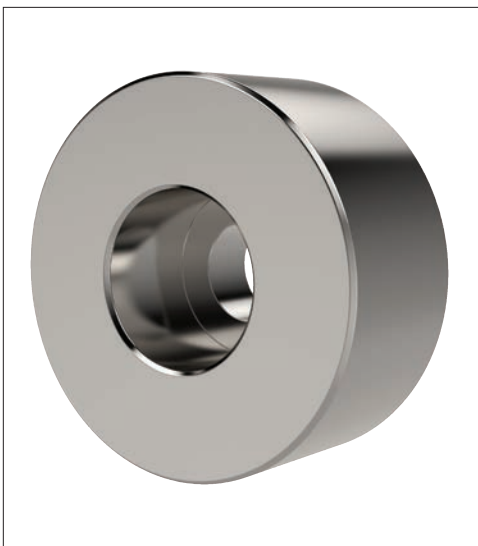

Pads of 17-4 Stainless, hardened to RC 43/46 provide solutions to applications where material selection is of greater importance; for example nuclear or food processing or pharmaceutical applications.

Stainless Pads