

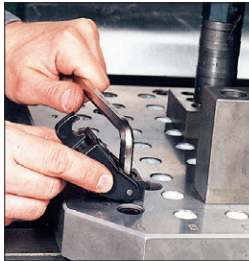

Our comprehensive range of clamping elements includes a compact and powerful workpiece clamping element, the chain clamping set no. 12700. This set was specifically designed for clamping large workpieces with round or arched surfaces.

Due to an increase in the bearing surface of the chain, the clamping force is distributed across the workpiece thereby reducing deformation.

Setting Up



1. Attach the hook unit and the take-up unit as close to the workpiece as possible.



2. Turn the knurled nut on the take-up unit until the pull rod is fully extended. Select the number of chain segments required for the workpiece and attach to the pull rod.



3. Fine adjustment of the chain length is made by tightening the knurled nut until the chain slightly touches the workpiece.



4. To clamp the workpiece connect the free end of the chain onto the hook unit. Using a hex key tighten the eccentric shaft, and ensure the lever is rotated to its fully locked position (180°). The workpiece is now clamped.

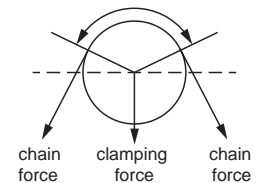

Important Factors in Selection of Chain Clamp

The clamping force achievable through the Wixroyd chain clamp set is dependent upon three factors:

- Workpiece diameter (see graph).
- Chain length and stretch (see graph).
- Contact angle of chain and workpiece (see table below right).

Chain Stretch at Specified Torques

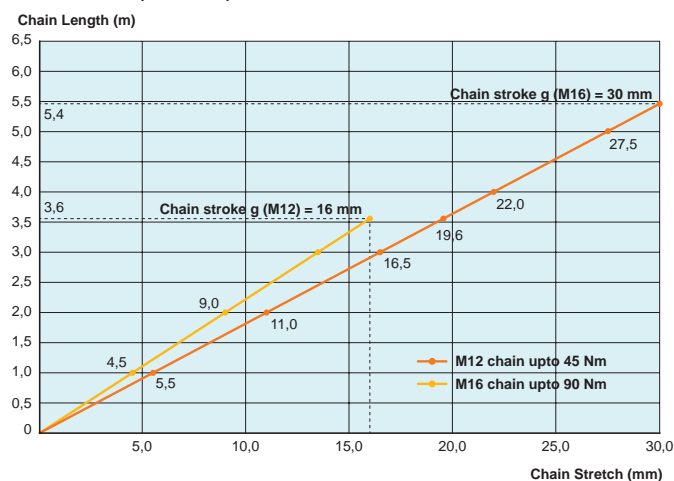

Chain Length and Stretch

Torque value of 50 Nm is used for M12 set.

Torque value of 90 Nm is used for M16 set.



Clamping with the chain clamp set.

Torque	$\alpha = 105^\circ$	$\alpha = 120^\circ$	$\alpha = 135^\circ$	$\alpha = 150^\circ$	$\alpha = 180^\circ$
M12 50Nm	80%	87%	92%	97%	100%
M16 90Nm	80%	87%	92%	97%	100%

Table of Clamping Force to Contact Angle α

Important Note: Achievable clamping force decreases as the contact angle of chain and workpiece (α) reduces. Please use the table above as a guide.

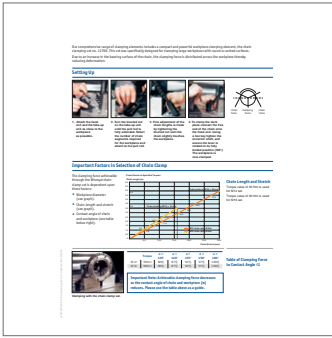

12700

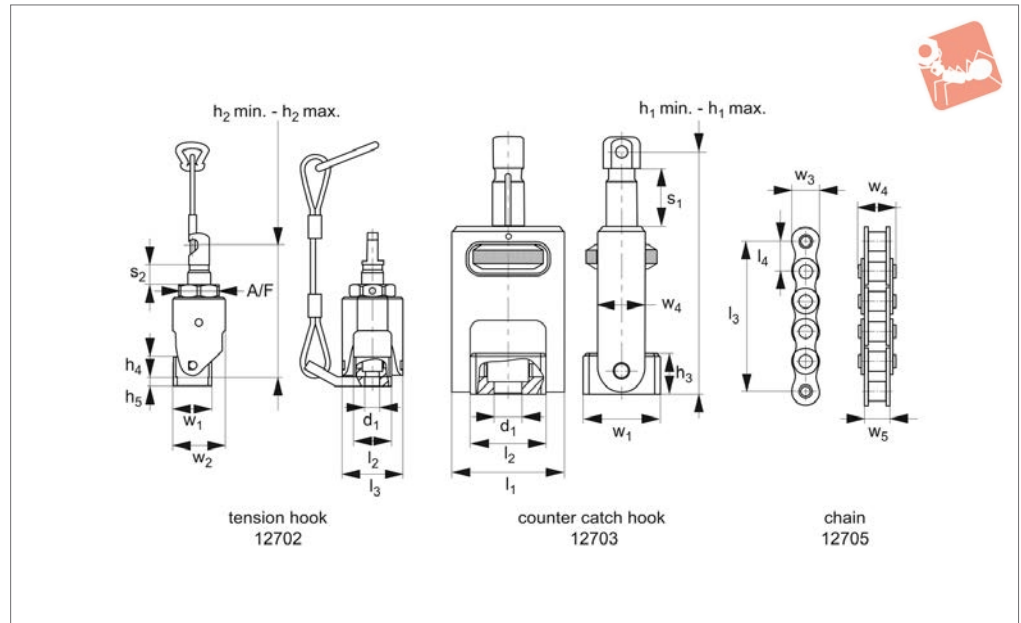

Material

Alloy steel.

Set contents:

- 1 x tension hook,
- 1 x take-up hook,
- 1 x clamp chain protection set,
- .W0112 (2 x 492mm, 1 x 238mm, 1 x 15,9mm),
- .W0116 (1x991mm, 1x229mm, 1x483, 1x25mm),
- 4 x split chain links,
- 6 x plastic protectors (to protect the work-piece),

1 x chain clamp protection lanyard.

Note: M20 and M24 clamp sets only have 3 chain lengths.

Technical Notes

For clamping valves, flanges, pump cases etc - can be used on fixture sub-plates or machine tables. The clamping force is generated by the eccentric shaft, and the force is determined by the take-up which is adjusted using the knurled screw. Please order T-nuts no. 24000 separately if

required.

Tips

The even distribution of the clamping force reduces workpiece deformation. The work-pieces are protected from marking of the chain by plastic protectors which are locked into the chain segments. Chains enable a large range of adjustment. See table opposite for details for achievable clamping forces.

Order No.	Size	For T-slot	Combined chain length max.	d_1	h_1 min.	h_1 max.	h_2 min.	h_2 max.	h_3	h_4	Weight g
12700.W0112	12	14, 16 or 18	1302	M12	83	108.0	100	118	18	18	853
12700.W0116	16	18, 20, 22 or 24	1829	M16	110	146.0	122	153	25	25	1902
12700.W0120	20	22 to 28	4940	M20	162	205.5	195	250	41	41	6037
12700.W0124	24	28 to 36	4940	M24	166	209.0	199	260	41	41	6040

Order No.	h_5	l_1	l_2	l_3	Permissible torque				A/F	Stroke s_1	Clamp stroke s_2	Clamping force kN max.
					Nm max.	w_1	w_2	w_4				
12700.W0112	8	50	34	54	45	34	47	21	36	25.0	18	15
12700.W0116	10	64	44	70	90	37	62	29	46	36.0	31	40
12700.W0120	10	91	64	98	190	58	86	48	65	43.5	55	75
12700.W0124	10	91	64	98	300	58	86	48	65	43.0	61	120



Chain Clamping Set with lanyard

Chain Clamping



chain clamping:
even distribution of clamping force-
little workpiece deformation.

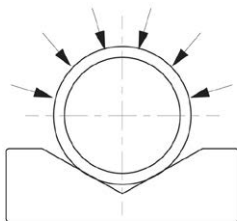

existing methods:
workpiece deformation caused by
pressure at a single clamping point.

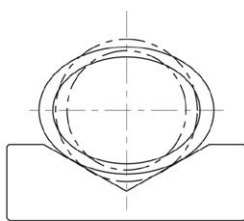



12702

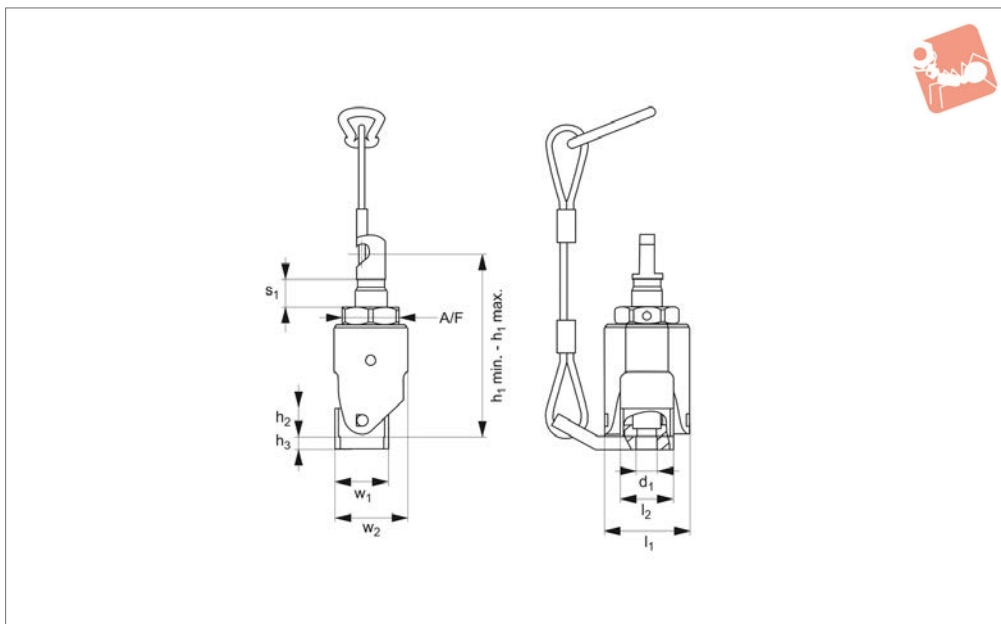

Material

Hardened and tempered alloy steel.

Technical Notes

For use with chain clamp set 12700.

Tension hook provides final clamping and tightening of component when chain clamp 12700 is used. Counter catch hook is for the initial pre-tightening of chain

prior to final clamping. Comes complete with safety lanyard.

Order No.	Size	For T-slot	d ₁	h ₁ min.	h ₁ max.	h ₂	h ₃	l ₁	l ₂	Torque to Nm max.	w ₁	w ₂	A/F	Clamp stroke s ₁	Clamping force kN max.	Weight g
12702.W0012	12	14, 16 of 18	M12	100	118	18	8	54	34	45	34	47	36	18	15	853
12702.W0016	16	18, 20, 22 or 24	M16	122	153	25	10	70	44	90	37	62	46	31	40	1902
12702.W0020	20	22 to 28	M20	195	250	41	10	98	64	190	58	86	65	55	75	6037
12702.W0024	24	28 to 36	M24	199	260	41	10	98	64	300	58	86	65	61	120	6040

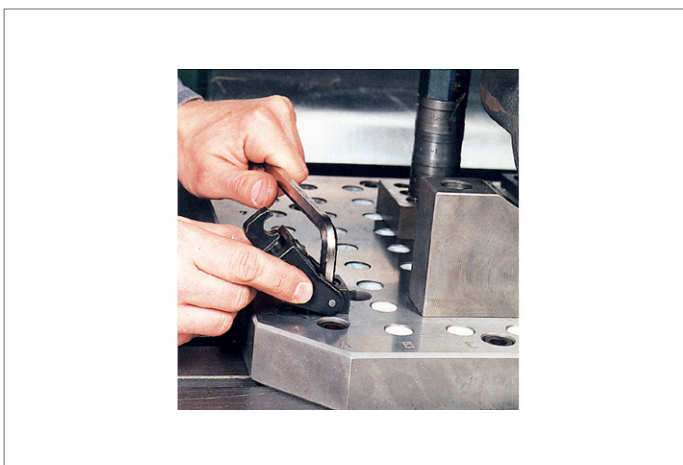
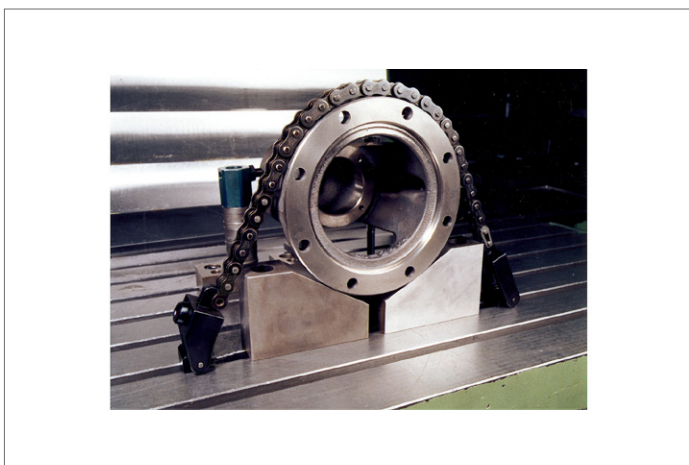



Counter Catch Hook for chain clamping set 12700

Chain Clamping

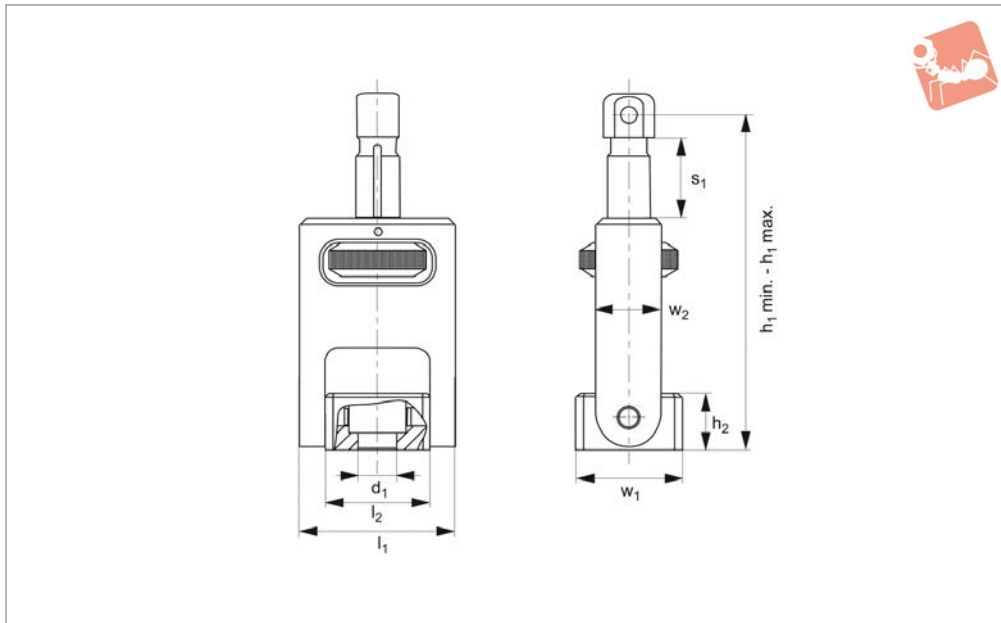

12703

CHAIN CLAMPING

Material
Alloy steel.

Counter catch hook is for the pre-tightening of chain prior to final clamping.

Technical Notes
For use with chain clamp set 12700.

Order No.	Size	For T-slot	d ₁	h ₁ min.	h ₁ max.	h ₂	l ₁	l ₂	w ₁	w ₂	Stroke s ₁	Clamping force kN max.	Weight g
12703.W0012	12	14, 16 or 18	M12	83	108.0	18	50	34	34	21	25.0	15	553
12703.W0016	16	18, 20, 22 or 24	M16	110	146.0	25	64	44	37	29	36.0	40	1235
12703.W0020	20	22 to 28	M20	162	205.5	41	91	64	58	48	43.5	75	4088
12703.W0024	24	28 to 36	M24	166	209.0	41	91	64	58	48	43.0	120	4145

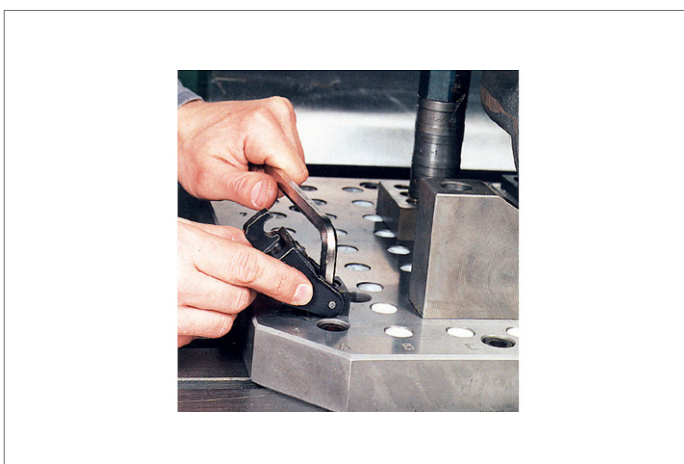



12704

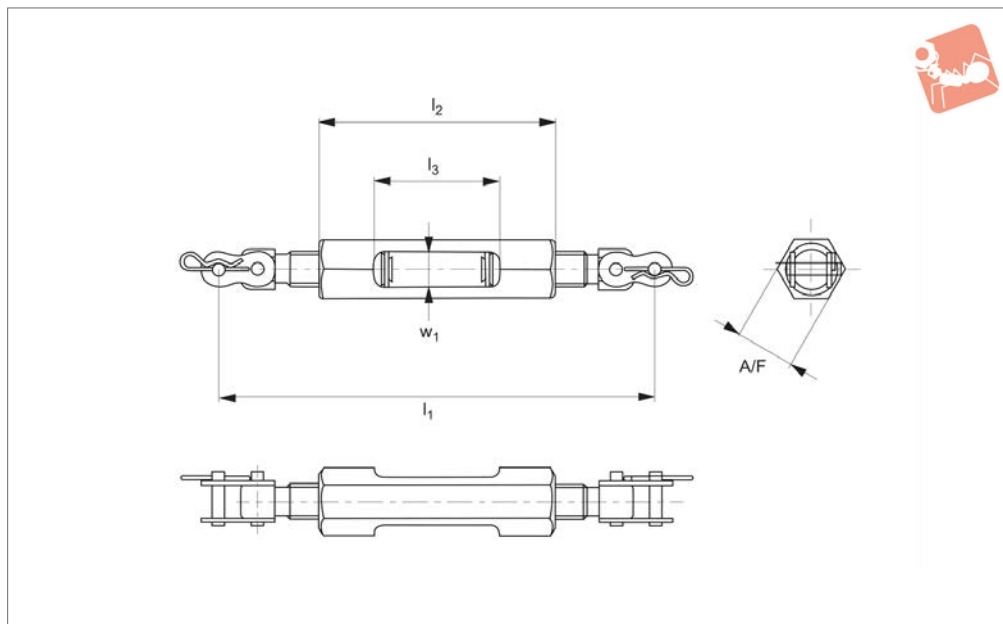

Material

Alloy steel.

Technical Notes

For use with chain clamp set 12700. The

turnbuckle is clamped between the chains using two locking links. The chain is pre-tensioned by turning, and the play (caused by lengthening of the chain) is removed.

Order No.	Size	l_1	l_2	l_3	w_1	A/F	Clamping force kN max.	Weight g
12704.W0012	12	111-147	97	52	14	24	15	240
12704.W0016	16	151-203	126	66	20	30	40	720
12704.W0020	20	206-270	180	100	31	50	75	2222
12704.W0024	24	214-284	180	105	31	50	120	3517

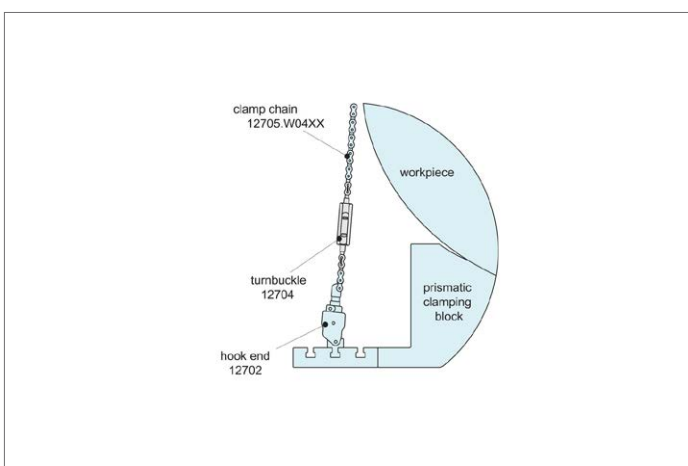

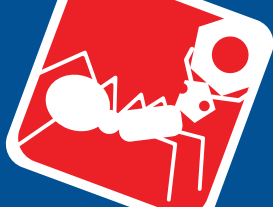

Chain Clamp Accessories

for chain clamping set 12700

Chain Clamping

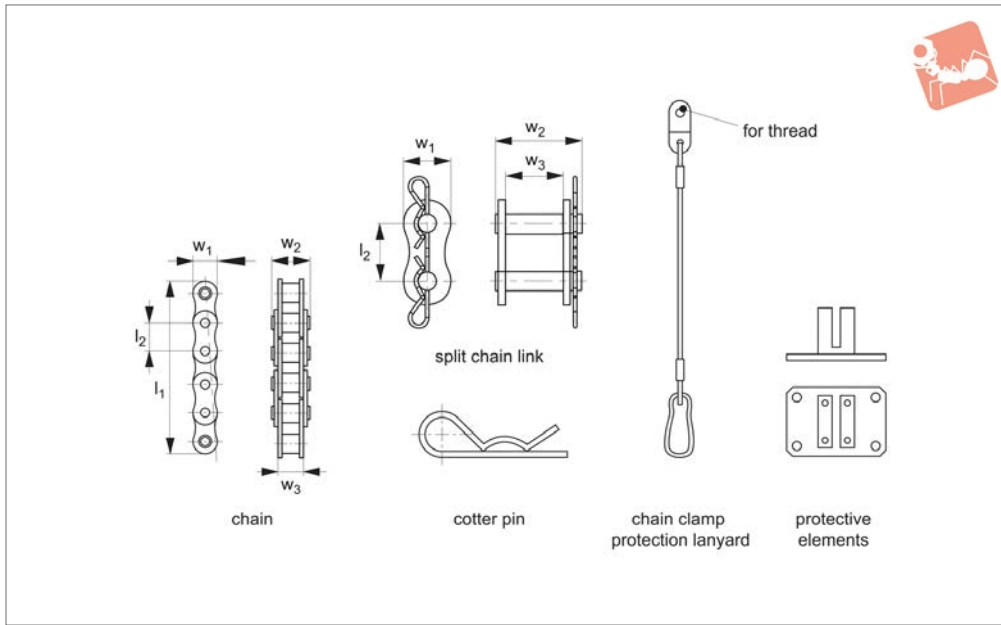

12705

CHAIN CLAMPING

Technical Notes

Lanyard: for use with chain clamp, when properly assembled prevents chain from snapping uncontrolled if chain breaks.

Protective element: can be placed between chain and workpiece to protect

surfaces.

Chain Links: for use to connect chain of different lengths to expand chain capacity and hence accommodate larger workpieces.

Chain: DIN8187, as well as being extended with the use of connecting links, can also

be shortened to suit requirements. Chain is pre-tensioned to minimise elongation.

Important Notes

If the lanyard system is damaged the entire lanyard set must be replaced.

Order No.	Size	Type	Length nom.	l_1	l_2	w_1	w_2	w_3	Clamping force to be secured kN max.	Qty/pack	Weight g
12705.W0012	12	Lanyard	-	-	-	-	-	-	15	-	280
12705.W0016	16	Lanyard	-	-	-	-	-	-	40	-	350
12705.W0020	20	Lanyard	-	-	-	-	-	-	75	-	1313
12705.W0024	24	Lanyard	-	-	-	-	-	-	120	-	1313
12705.W0112	12	Workpiece Protector	-	-	-	-	-	-	-	6	3
12705.W0116	16	Workpiece Protector	-	-	-	-	-	-	-	6	5
12705.W0120	20	Workpiece Protector	-	-	-	-	-	-	-	6	10
12705.W0124	24	Workpiece Protector	-	-	-	-	-	-	-	6	16
12705.W0212	12	Chain Link	-	-	15.87	14	22	13	15	-	15
12705.W0216	16	Chain Link	-	-	25.40	21	39	25	40	-	67
12705.W0220	20	Chain Link	-	-	31.75	26	44	29	75	-	113
12705.W0224	24	Chain Link	-	-	38.10	33	59	38	120	-	274
12705.W0312	12	Cotter Pin	-	-	-	-	-	-	-	10	0.5
12705.W0316	16	Cotter Pin	-	-	-	-	-	-	-	10	1.0
12705.W0320	20	Cotter Pin	-	-	-	-	-	-	-	10	2.2
12705.W0324	24	Cotter Pin	-	-	-	-	-	-	-	10	6.5
12705.W0412	12	Chain	125	111	15.87	15	20	13	15	-	114
12705.W0413	12	Chain	250	238	15.87	15	20	13	15	-	228
12705.W0414	12	Chain	500	492	15.87	15	20	13	15	-	455
12705.W0415	12	Chain	1000	1000	15.87	15	20	13	15	-	910
12705.W0416	16	Chain	125	127	25.40	21	23	25	40	-	335
12705.W0417	16	Chain	250	229	25.40	21	23	25	40	-	670
12705.W0418	16	Chain	500	483	25.40	21	23	25	40	-	1340
12705.W0419	16	Chain	1000	991	25.40	21	23	25	40	-	2680
12705.W0420	20	Chain	1000	984	31.75	26	44	29	75	-	3720
12705.W0421	20	Chain	1500	1492	31.75	26	44	29	75	-	5580
12705.W0422	20	Chain	2000	2000	31.75	26	44	29	75	-	7440
12705.W0424	24	Chain	1000	1028	38.10	33	54	38	120	-	7050
12705.W0425	24	Chain	1500	1485	38.10	33	54	38	120	-	10575
12705.W0426	24	Chain	2000	2019	38.10	33	54	38	120	-	14100

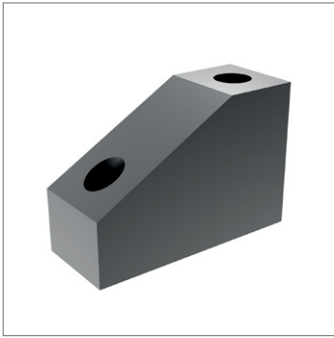

12706

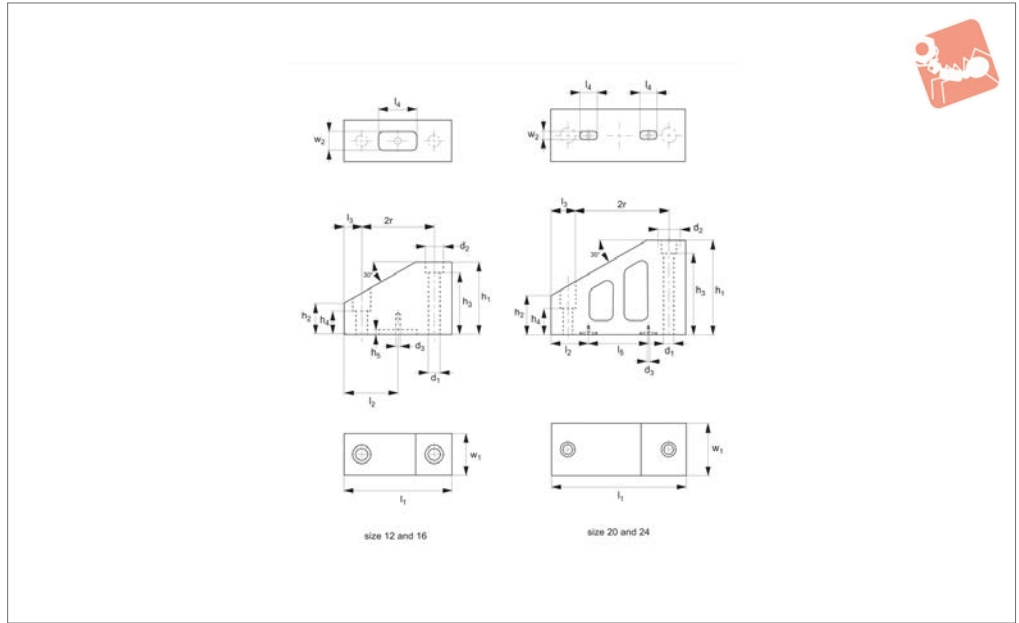

Technical Notes

Ideal for use when clamping components with chain clamp set 12700. 2 off prisims

provide ideal support for components with large circumferences. **Sold individually.**

Order No.	Size	2r	d ₁	d ₂	d ₃	h ₁	h ₂	h ₃	h ₄	h ₅	l ₁	l ₂	l ₃	l ₄	l ₅	w ₁	w ₂	Weight g
12706.W0012	12	80	13.5	20	M 6	80	35	67	27	5.5	118	59	19	42	-	47	20	3230
12706.W0016	16	100	17.5	26	M 6	100	44	33	33	5.5	148	74	24	44	-	47	20	3960
12706.W0020	20	270	22.0	33	M 6	250	102	161	91	5.5	360	100	45	44	160	78	20	32455
12706.W0024	24	270	22.0	40	M 6	250	102	161	91	5.5	360	100	45	44	160	78	20	31760

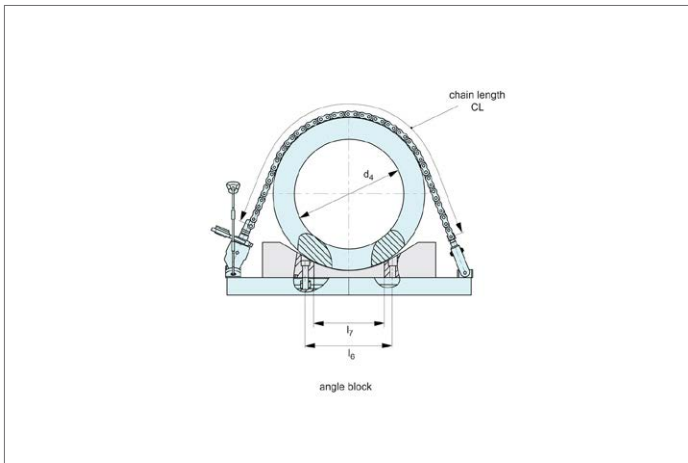



Chain Clamp Sets - 16kN for large diameter clamping

Chain Clamping

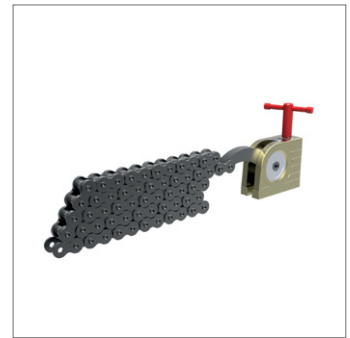
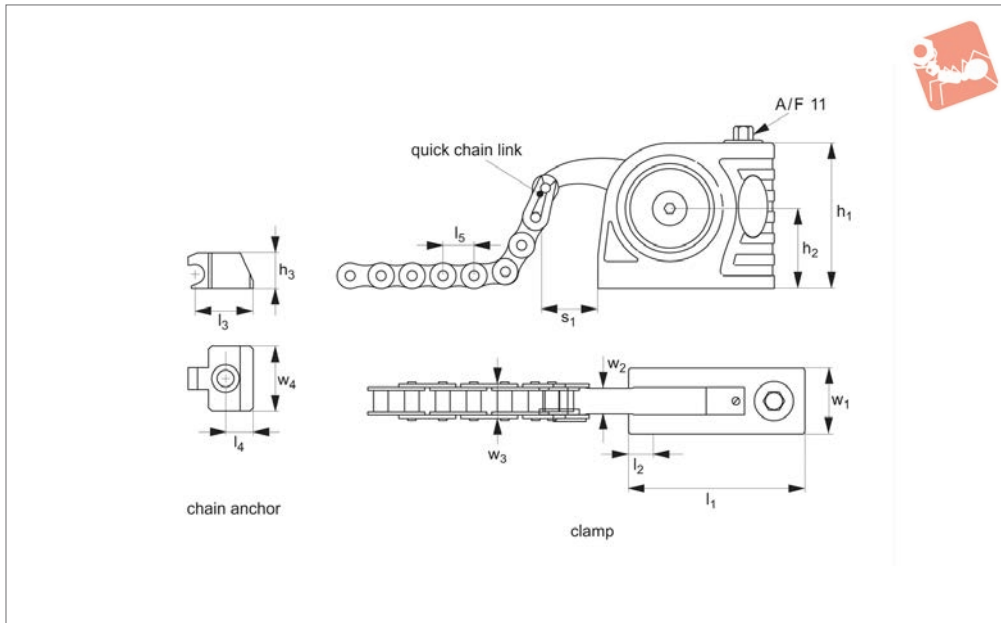

12750

CHAIN CLAMPING

Material

Clamp: as part no. 10650.
Chain: steel, 19,05mm pitch - 1 metre.
Chain anchor: steel.
Quick chain link: steel.

diameter workpieces.

Extra lengths of chain can be ordered and linked together.
Clamp or unclamp with a simple turn of the red key. The chain can then easily be removed clear from the workpiece.

Tips

Chains with rubber protective pads can also be provided on request (min. radius 200mm).

Technical Notes

Provides strong and even clamping of large

Order No.	Description	h_1	h_2	h_3	l_1	l_2
12750.W0040	Set: Clamp, 1m Chain, Chain Anchor	89	49	-	108	12.5
12750.W0900	Chain - 1m	-	-	-	-	-
12750.W0905	Quick Chain Link	-	-	-	-	-
12750.W0910	Chain Anchor	-	-	22	-	-

Order No.	l_3	l_4	l_5	w_1	w_2	w_3	w_4	A/F	Clamp reach s_1	Clamping force kN max.
12750.W0040	-	-	-	40	16	-	-	11	33	16
12750.W0900	-	-	19.05	-	-	19.5	-	-	-	-
12750.W0905	-	-	19.05	-	-	-	-	-	-	-
12750.W0910	26	17	-	-	-	-	40	-	-	-

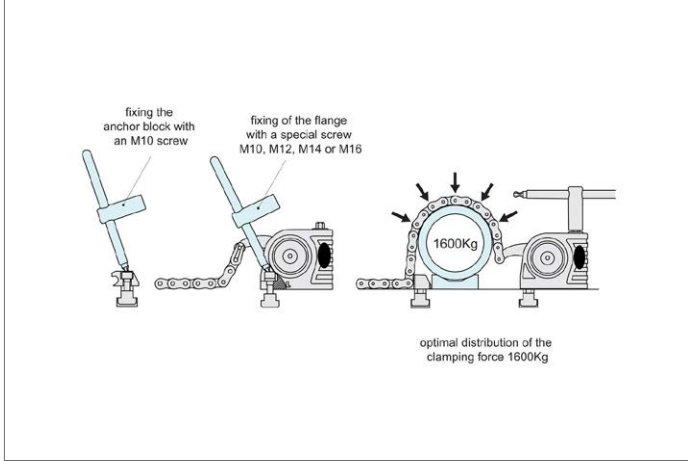



Chain Clamp Sets - 50kN for large diameter clamping

Chain Clamping

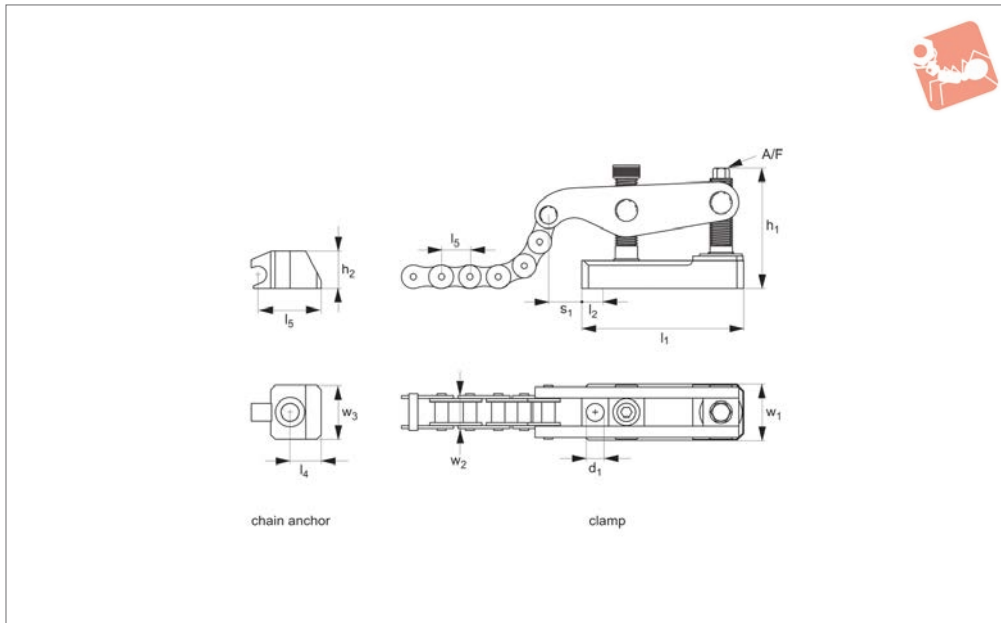

12752

CHAIN CLAMPING

Material

Clamp - as part no. 10678.
Chain - steel, 25,4 pitch. 3m long.
Chain anchor - steel.

Provides strong and even clamping of large diameter workpieces.
Clamp or unclamp with a simple turn of hexagon socket. Chain can be easily removed clear from the workpiece.
Please use socket head cap screw of

strength class 12,9 for mounting. Please order T-nuts to suit your application separately, if required see part 24000.

Technical Notes

Heavy clamping forces of up to 50kN.

Order No.	Description								d ₁	h ₁	h ₂	l ₁	l ₂
12752.W0001	Set: Clamp, Chain (3m), Chain Anchor								17	111	35	108	12
Order No.	l ₃	l ₄	l ₅	w ₁	w ₂	w ₃	A/F	Clamp reach s ₁	Clamping force kN max.				
12752.W0001	57	28	25.4	50	25.4	50	13	30	50				

